

ORIGAMI TANTEIDAN 17th CONVENTION

第17回

折紙探偵団
コンベンション

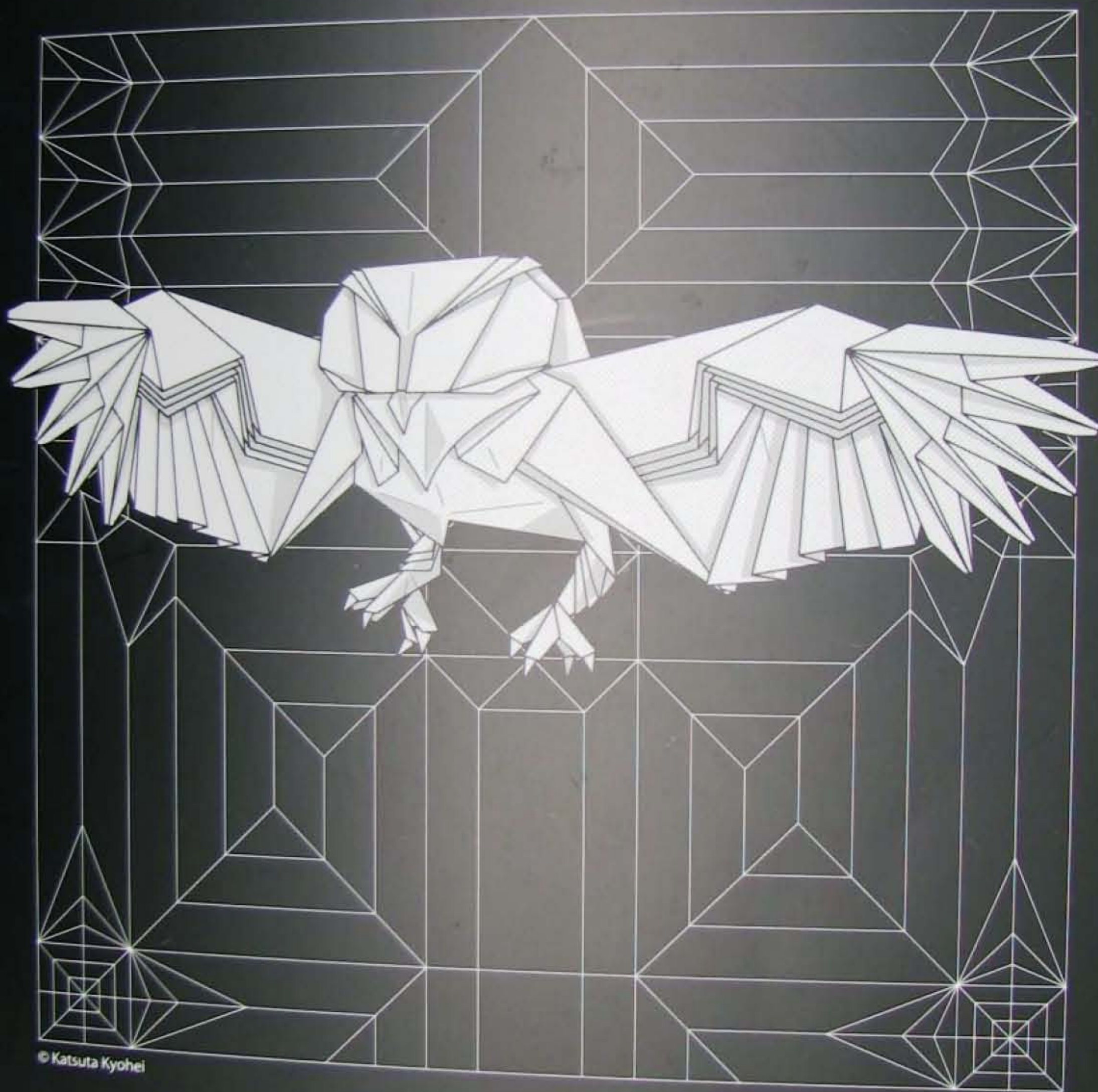

折り図集

Vol.17

発行・日本折紙学会

17th Origami Tanteidan Convention

第17回
折紙探偵団
コンベンション

Japão Burajirujin

www.japaoburajirujin.blogspot.com

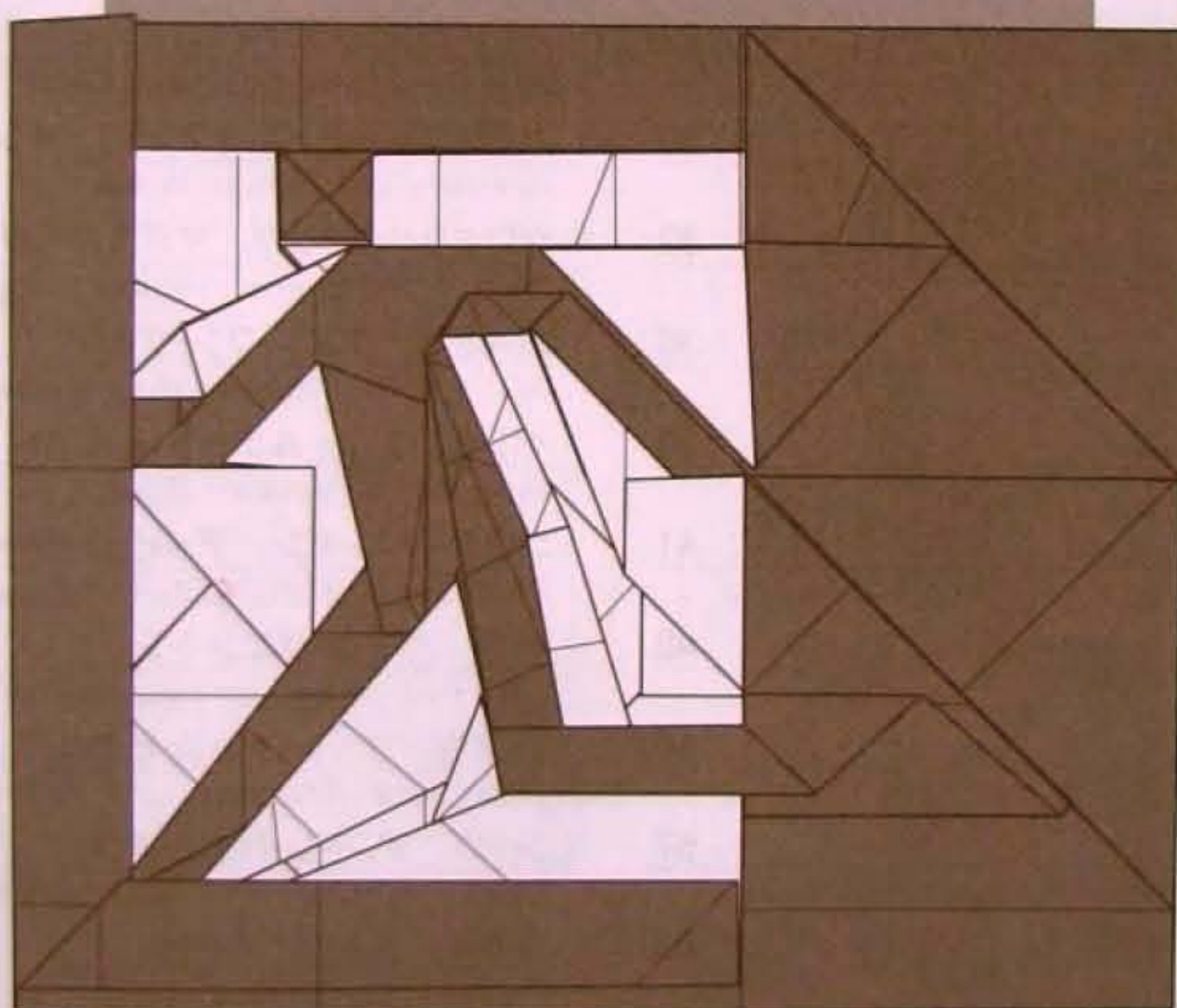

© Morsue Kei

折り図集

Vol. 17

発行・日本折紙学会

CONTENTS

折り図記号 Symbols for Folding	3
基本形・沈め折り Preliminary Bases and Sink	4
国内編: Models by Japanese Folders	
ポリロッド / 川村みゆき POLYROD / Kawamura Miyuki	6
四角深箱うず隠し / 川崎敏和 Cube Box Elegant / Kawasaki Toshikazu	8
四つ星の箱 / 川崎敏和 Four-Star Box / Kawasaki Toshikazu	11
コッホの雪片曲線(繰り返し2回) / 池上牛雄 Koch's Snowflake (iteration2) / Ikegami Ushio	14
Origami Cube Puzzle ~type-P3-4. / 霞 誠志 Origami Cube Puzzle ~type-P3-4. / Kasumi Seishi	18
コーヒードリッパー / 小方弘巳 Coffee Dripper Cafe Rat / Ogata Hiromi	23
ジャコランタン / 前川 淳 Jack-o'-Lantern / Maekawa Jun	24
ちいさなおしろ16A・16B / 北條高史 Small Castle / Hojyo Takashi	26
祝かぶと / 浜田 勇 Samurai Helmet / Hamada Isamu	28
ティーバッグのゾウ / 小野友彰 Tea-bag Elephant / Ono Tomoaki	30
サンタのオーナメント / 小松英夫 Santa Clause Ornament / Komatsu Hideo	32
胸像 / 中井 努 Bust / Nakai Tsutomu	35
お月さま / 田中幹人 Fancy Moon / Tanaka Mikito	38
非常口 / 森末 圭 Escape / Morisue Kei	41
ウサギ / 川畑文昭 Rabbit / Kawahata Fumiaki	48
ウサギ / 萩原 元 Rabbit / Hagiwara Gen	50
ねこ / 川畑文昭 Cat / Kawahata Fumiaki	57
銀の馬 / 霞 誠志 Silver Horse / Kasumi Seishi	63
イルカ / 青木 良 Dolphin / Aoki Ryo	71
ニシキゴイ / 宮島 登 Carp / Miyajima Noboru	74
流金 / 柏村卓朗 Ryukin / Kashiwamura Takuro	80
フクロウ / 勝田恭平 Owl / Katsuta Kyohei	92
ふくろう2 / 津田良夫 Owl #2 / Tsuda Yoshio	104
スピノサウルス / 神谷哲史 Spinosaurus / Kamiya Satoshi	111
バラ / 山口 真 Makoto Rose / Yamaguchi Makoto	128

Japão Burajirujin

www.japaoburajirujin.blogspot.com

海外編: Models by Foreign Folders

エストリーニャ / イザ・クライン Estrelina / Isa Klein	134
平織り / アンナ・カストランガー Tessellation / Anna Kastlunger	136
兜 / ボレスラウ・ガーゴル Samurai Helmet / Boleslaw Gargol	140
金銭龜 / 羅瑜 MONEY TURTLE / LO YU	142
家 / ロマン・ディアス House / Roman Diaz	144
マジックフラワー / イラン・ガリビ Magic Flower / Ilan Garibi	146
蝶とハート / アンドレイ・ルキヤノフ Heart with butterfly / Lukyanov Andrey	149
ツタンカーメン / ビクトリア・セーロワ Tutankhamen mask / Victoria Serova	154
ハト / ロマン・ディアス Blue Bar Pigeon / Roman Diaz	160
ハミングバード / ライアン・ウェルシュ Hummingbird / Ryan Welsh	164
クロエリハクチョウ / マヌエル・シルゴ Swan of Patagonia / Manuel Sirgo	170
おんどり / グエン・フン・クオン ROOSTER / Nguyen Hung Cuong	173
ペンギン / フェルナンド・ヒルガド Pinguino / Fernando Gilgado	176
コウテイペンギン / デイビット・ジャンケ PINGUINO EMPERADOR / David Llanque	180
金魚 / グエン・グエン・トン Gold Fish / Nguyen Nguyen Thong	186
三葉虫 / チャン・チュン・ヒエユ "Fish base" Trilobites / Tran Trung Hieu	189
シャコ / アンドレイ・エルマコフ Mantis shrimp op.62 / Andrey Ermakov	200
ウサギ / ジェイソン・クー Rabbit / Jason Ku	206
ネズミ 2 / ライアン・マクドネル Rat 2 / Ryan MacDonell	211
スカンク / マーク・カーシェンバウム Skunk / Marc Kirschenbaum	216
子犬 / ノア・バウ・フイ PUPPY / Noa Bau Huy	220
ドーベルマン / アレス・アランヤ Doberman Pinscher / Ares Alanya	230
バビルサ / クエンティン・トロリップ Babirusa / Quentin Trollip	240
ブロングホーン / クエンティン・トロリップ Pronghorn / Quentin Trollip	250
翼のある狼 / フリオ・エドアルド・コンドリ Lobo Alado / Julio Eduardo Conderi	260

折

折り線の

谷折り線

手前に折

Fold pa

折り方の

中わり折

①

①

①

①

①

①

①

①

①

①

①

①

①

①

①

①

①

①

①

①

①

①

①

①

①

①

①

①

①

①

①

①

①

①

①

①

①

①

①

①

①

①

①

①

①

①

①

①

①

折り図記号 Symbols for Folding

折り線の種類 Types of crease lines

谷折り線 Valley fold

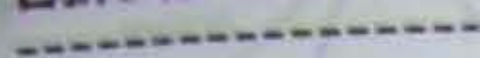

手前に折る
Fold paper forwards

谷折り
Valley fold



山折り線
Mountain fold



後ろへ折る
Fold paper backwards

山折り
Mountain fold

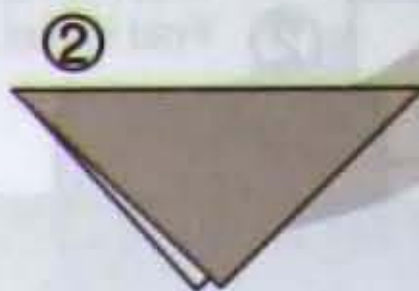

折り方の技法 Basic Folding Skills

中わり折り Inside-reverse fold

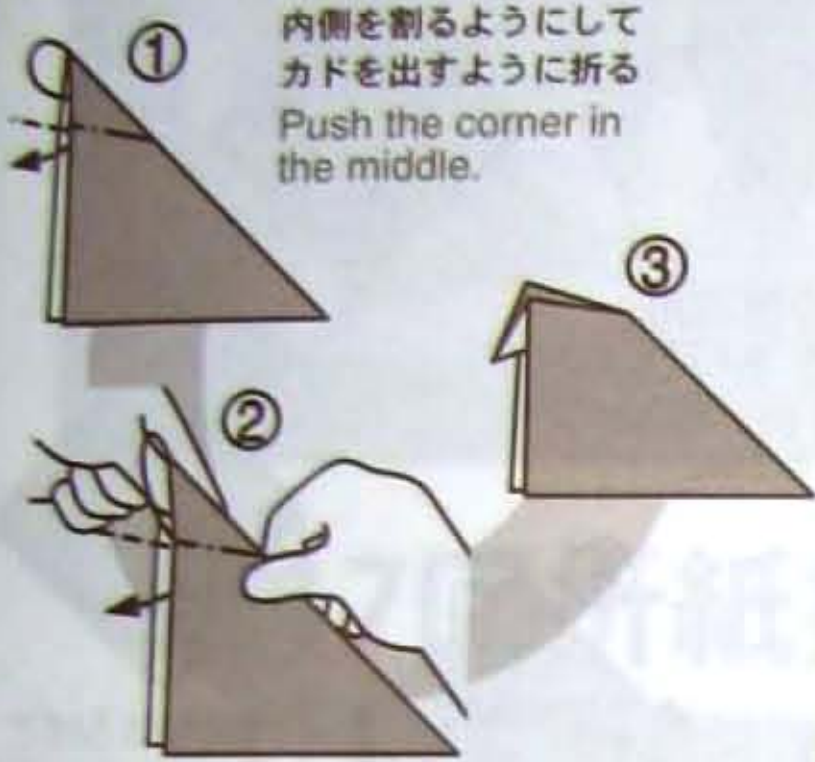

内側を割るようにして
カドを出すように折る
Push the corner in
the middle.

かぶせ折り Outside-reverse fold

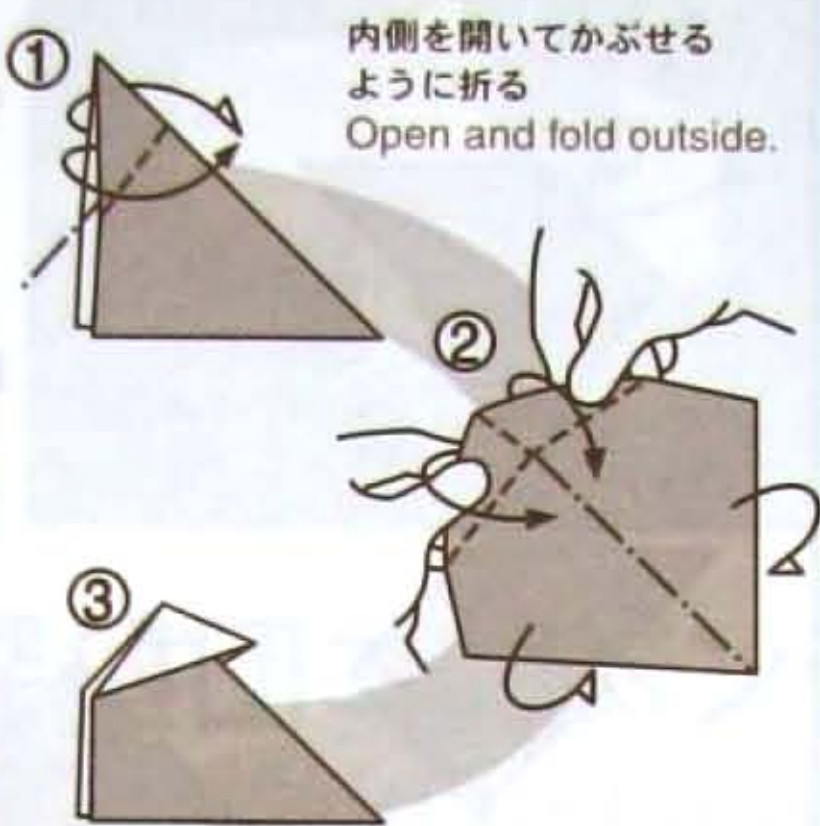

内側を開いてかぶせる
ように折る
Open and fold outside.

内側をひろげてつぶすように折る
Squash fold

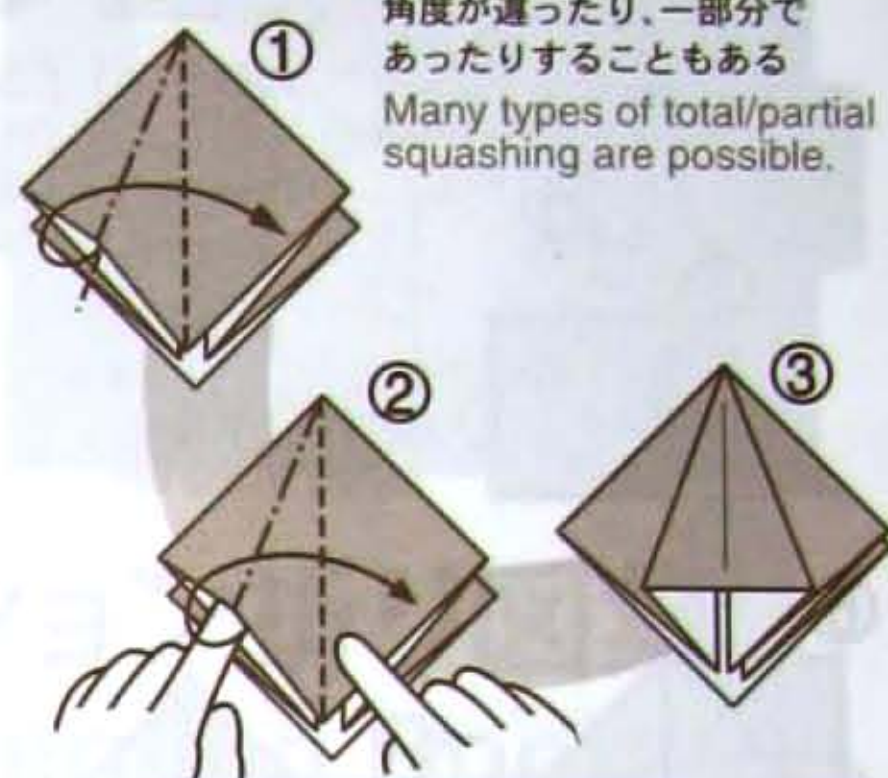

角度が違ったり、一部分で
あったりすることもある
Many types of total/partial
squashing are possible.

いろいろな記号 Symbols

折り筋をつける
Making a crease line

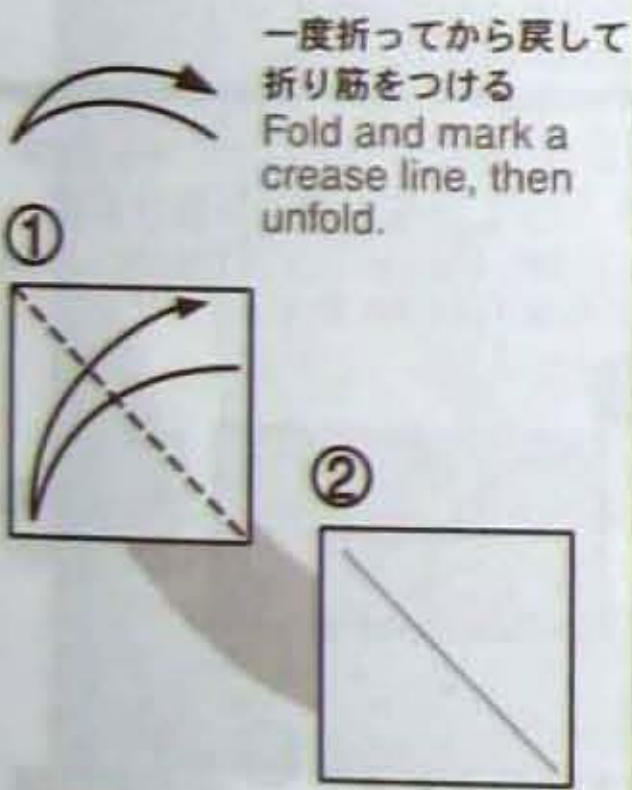

一度折ってから戻して
折り筋をつける
Fold and mark a
crease line, then
unfold.

裏返す Turn paper over

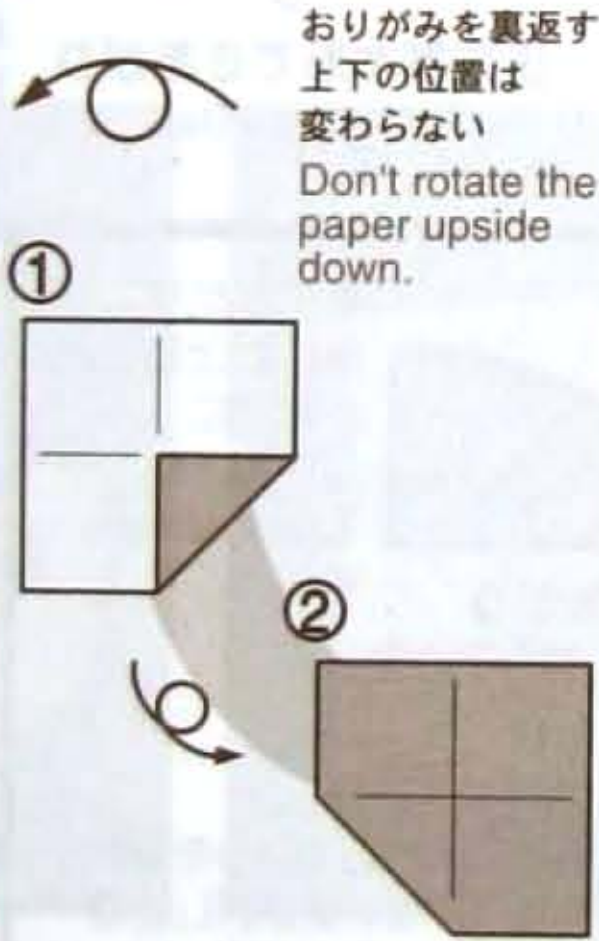

おりがみを裏返す
上下の位置は
変わらない
Don't rotate the
paper upside
down.

段折り Pleat fold

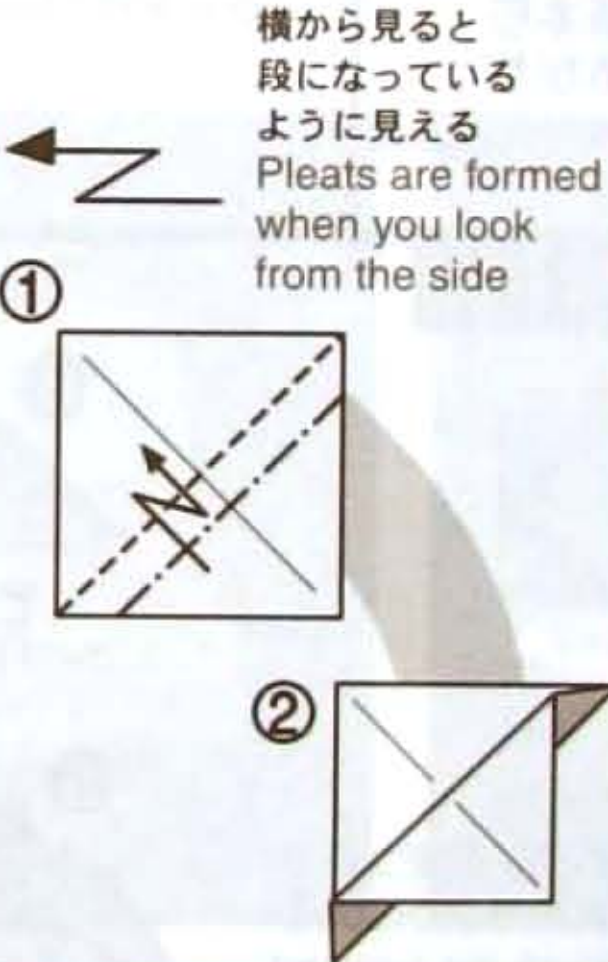

横から見ると
段になっている
ように見える
Pleats are formed
when you look
from the side

下の部分を出すように折る

Release bottom flap
when making a fold

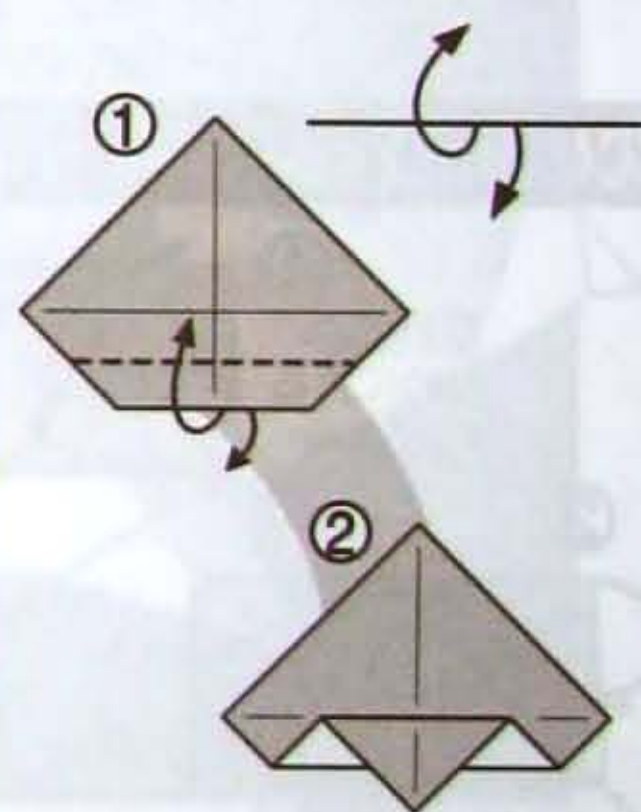

次の図が
大きくなる
A magnified view

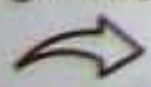

仮想線・透視線
A hidden line

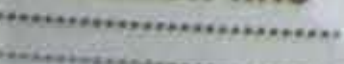

押す・つぶす
Push paper in



引き出す
Pull out

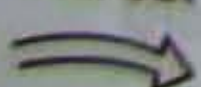

ひろげる Open up



○と○を
合わせて折る
Match circled points



巻くように折る
Roll the flap by
repeated folds

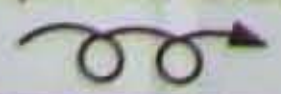

注意するところ
Marked points



次の図の見る位置が変わる
Paper position changes
(rotation)

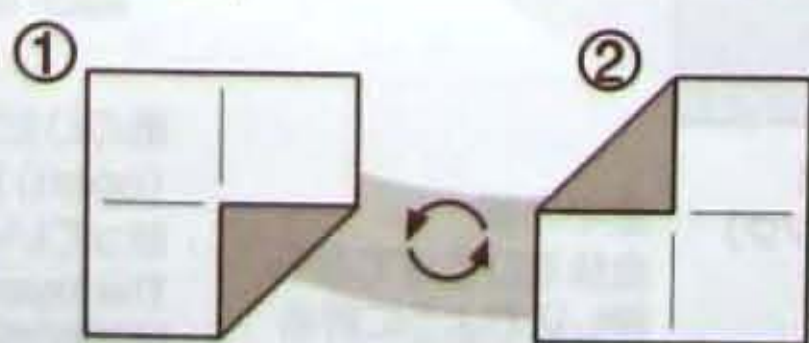

視点が大きく変わる場合
この記号の位置から見る
The viewpoint shifts to
this position.



等分記号 Division

長さの等分 Dividing the length



数字で表す場合もある
The ratio is often represented
with numbers.

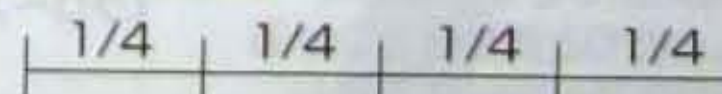

角度の等分
Dividing the angle



1つの図で2種類の
等分を表す場合

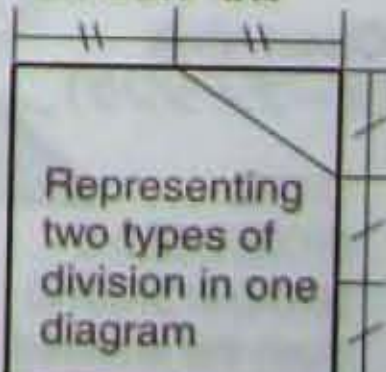

基本形 / 沈め折り Preliminary Bases and Sink

基本形 Preliminary bases

風船基本形 Water Bomb Base

① ② ③ ④ ⑤ ⑥ ⑦

① 半分に折る
Fold in half.

② 半分に折る
Fold in half again.

③ 内側をひろげて
つぶすように折る
Open and squash.

④ 反対側に折る
Swivel to the left.

⑤ 内側をひろげて
つぶすように折る
Open and squash.

⑥ 反対側に折る
Swivel to the left.

⑦ 内側をひろげて
つぶすように折る
Open and squash.

**風船基本形
できあがり**
The Water Bomb Base
completed.

正方基本形と鶴の基本形 Preliminary Base / Bird Base

① ② ③ ④ ⑤ ⑥ ⑦ ⑧ ⑨ ⑩ ⑪

① 三角に折る
Fold corner to corner.

② 三角に折る
Fold in half.

③ 内側をひろげて
つぶすように折る
Open and squash.

④ 反対側に折る
Swivel to the left.

⑤ 内側をひろげて
つぶすように折る
Open and squash.

⑥ 反対側に折る
Swivel to the left.

⑦ 内側をひろげて
つぶすように折る
Open and squash.

⑧ 縁を中心に合わせて
折り筋をつける
Fold the lower edges
to the center diagonal.

⑨ 内側をひろげて
つぶすように折る
Open, swivel up
and squash.

⑩ 反対側も
⑧~⑨と同じ
Repeat ⑧~⑨
on the back.

⑪ 鶴の基本形
できあがり
The Bird Base
completed.

正方基本形できあがり
The Preliminary Base
completed.

沈め折り Open sink / Closed sink

① カドを
斜めに折る
Fold down.

② カドを内側に折る
Inside reverse fold.

③ 沈め折りをする部分に
しっかりと折り筋をつける
Mark the crease line to
use for sink.

④ つけた
折り筋を使って
沈めるように折る
Push the arrowed corner inside ...

**Open sink
(オープン・シンク)**

途中の図
紙の重なりを開か
ないまま押し込む
ように折る
without opening
the corner.
Push in with layers
overlapped to
each other.

途中の図
全体をひろげてから
押し込むように折る
After opening the
corner lightly,
push in without
overlapping layers.

紙のひだが開いた
(open)かたち
になっている
The layers can be
reopened.

紙のひだが
閉じた (closed)
かたち
になっている
The layers are
locked.

できあがり
Closed sink completed.

できあがり
Open sink completed.

ひだの形によってはclosed sink
にしかできない場合もあります
Certain complexes of layers allows
only for closed sink.

① カドを
斜めに折る
Fold down.

② 沈め折りをする
部分にしっかりと
折り筋をつける
Mark the crease line
to use for sink.

③ つけた折り筋を
使って沈める
ように折る
Push in the corner.

④ **できあがり**
The closed sink completed.

Japão Burajirujin

www.japaoburajirujin.blogspot.com

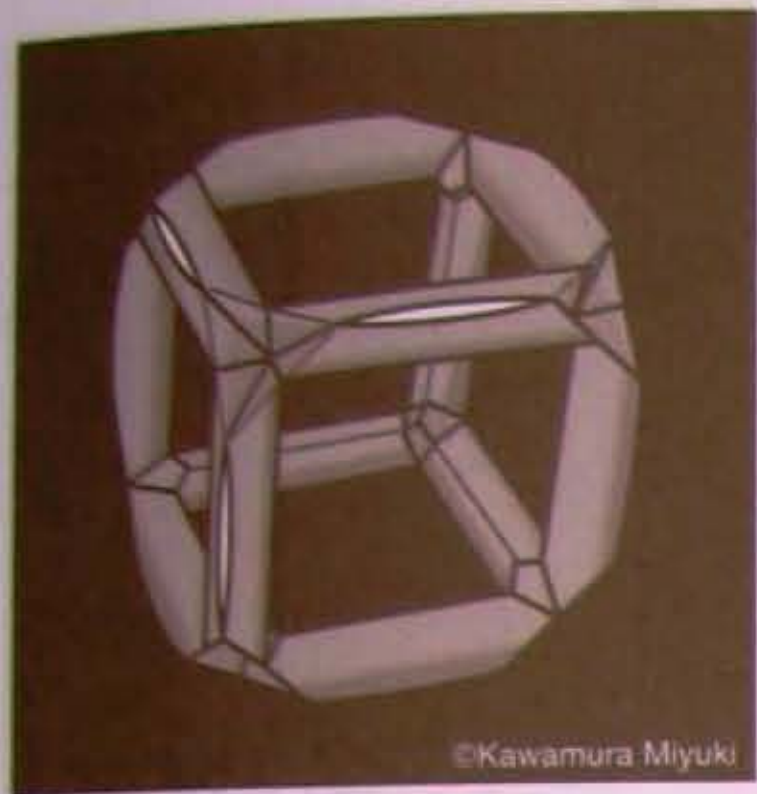

©Kawamura Miyuki

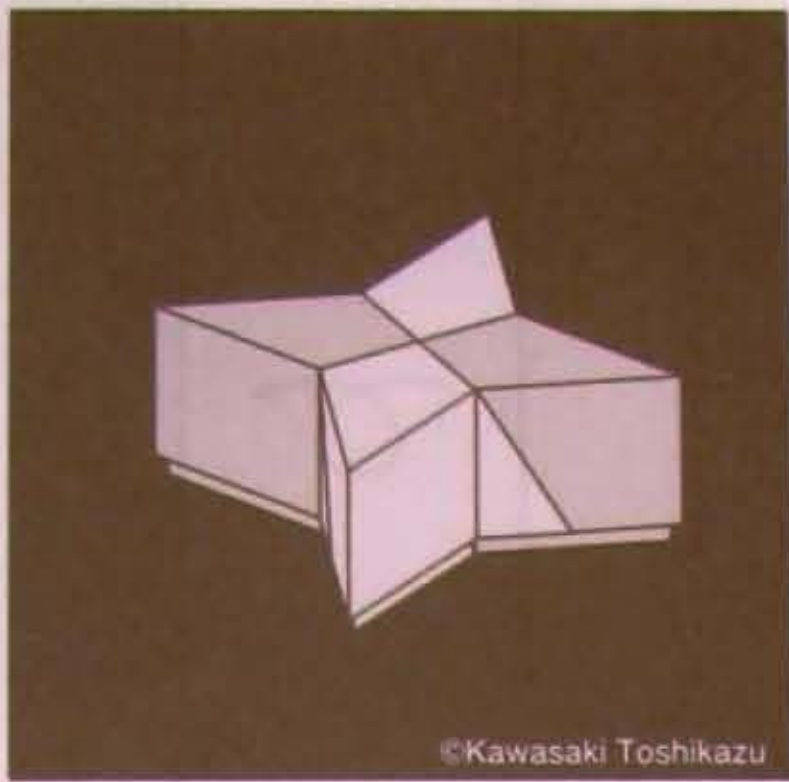

©Kawasaki Toshikazu

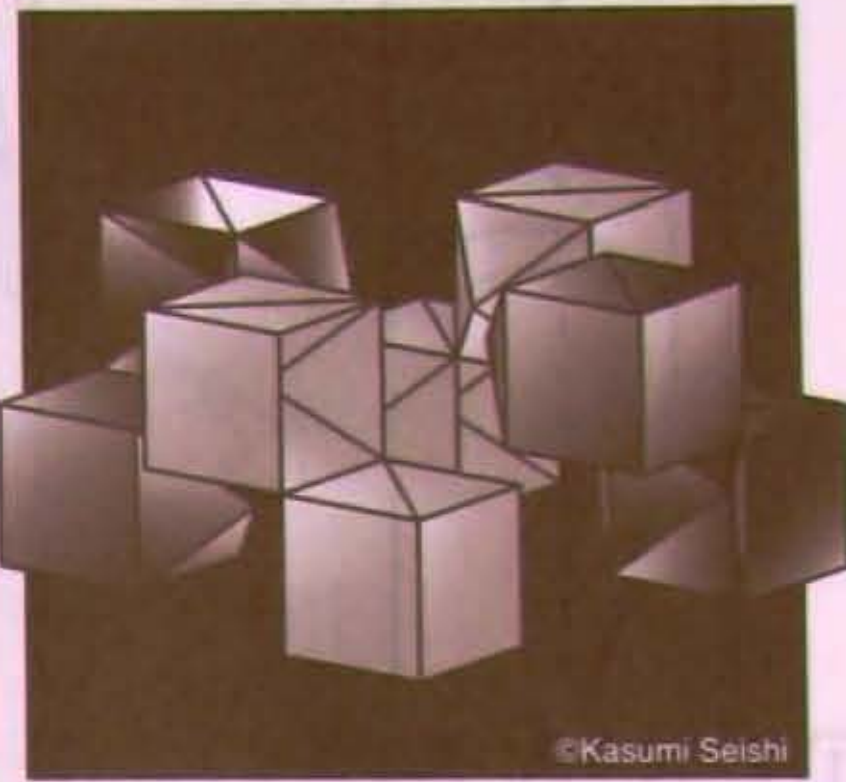

©Kasumi Seishi

第17回折紙探偵団コンベンション折り図集

17th Origami Tanteidan Convention Book

国内編 / Models by Japanese Folders



©Kawahata Fumiaki



©Yamaguchi Makoto

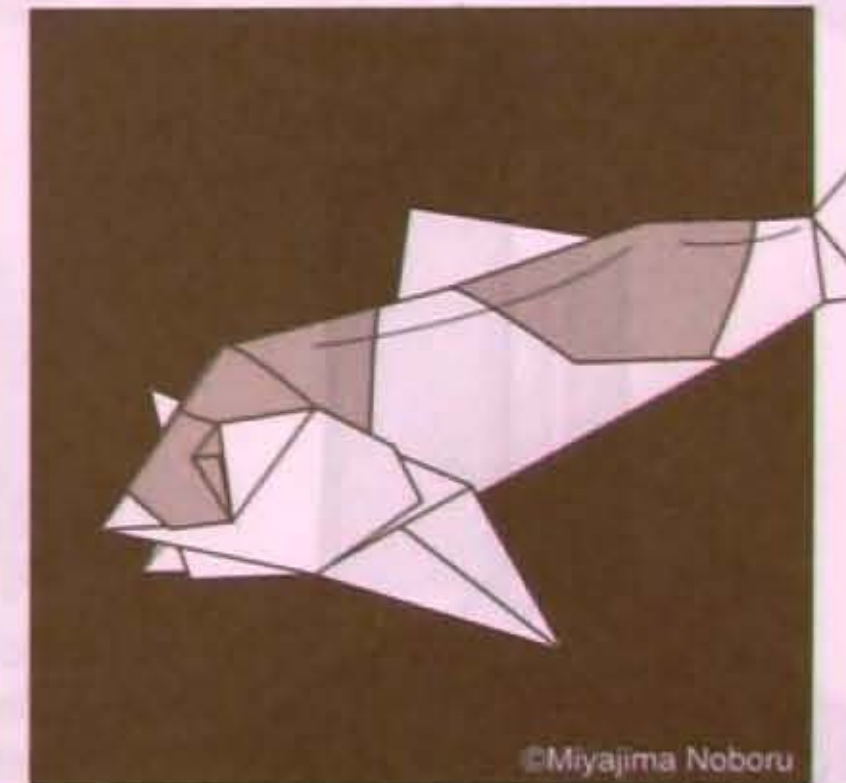

©Miyajima Noboru

胴体の部分は紙のハリを利用して膨らませると綺麗に
できます。ツルの背中を膨らませる要領に似ています。
To make tube good shape, use tension of
paper. It is similar to make a back of crane.

ポリロッド

POLYROD

©2011 Miyuki Kawamura
川村みゆき

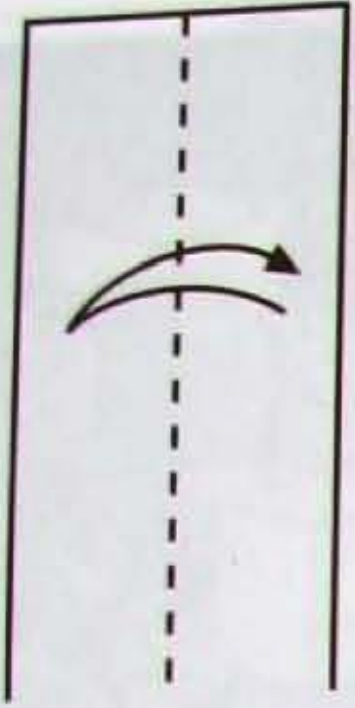

① 2:1より長い長方形
用紙を使います。下側
も同様に折っていきます。
Use a rectangular paper
longer than 2:1. Do the
same steps on the other
end.

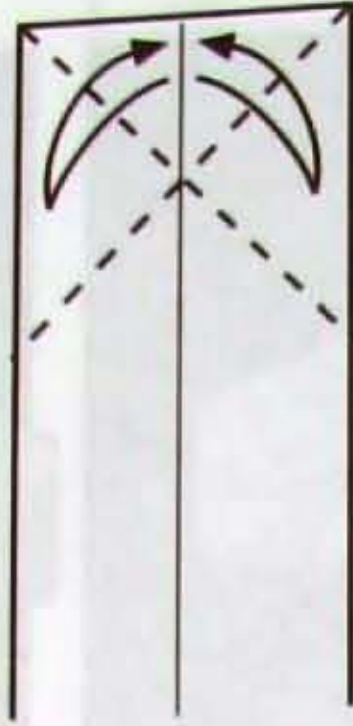

②

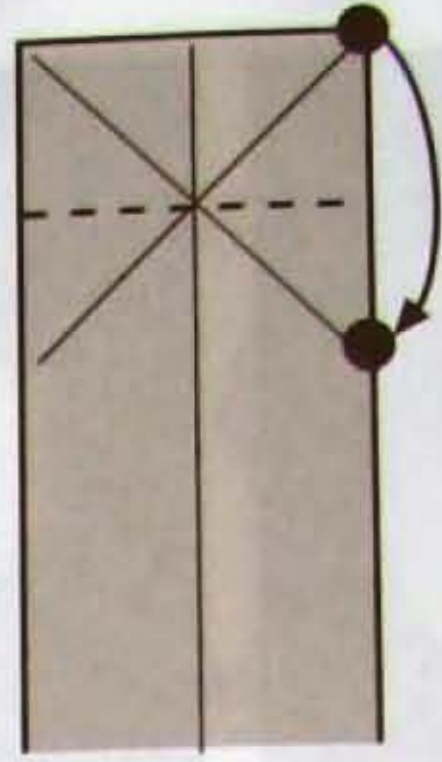

③

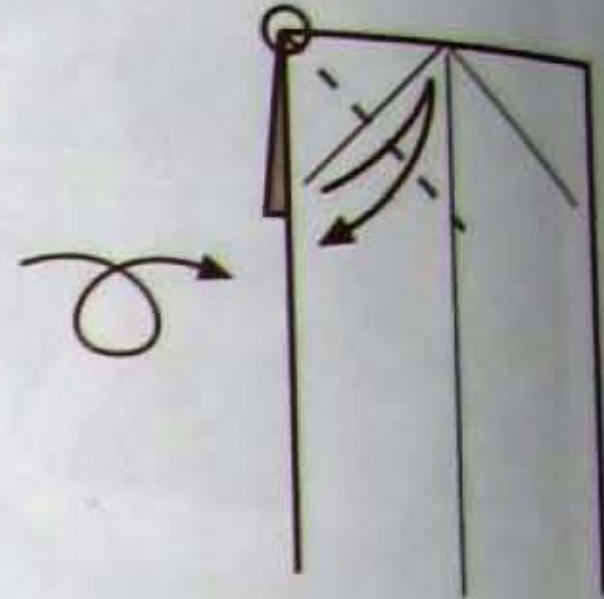

④ 1枚だけ折る
Fold only the
upper layer and
unfold.



⑧

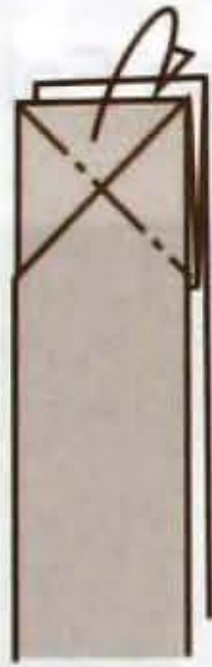

⑦ カドを中へ折り込む。
向こう側も同じ。
Fold corner down.
Do the same on the
other corner.

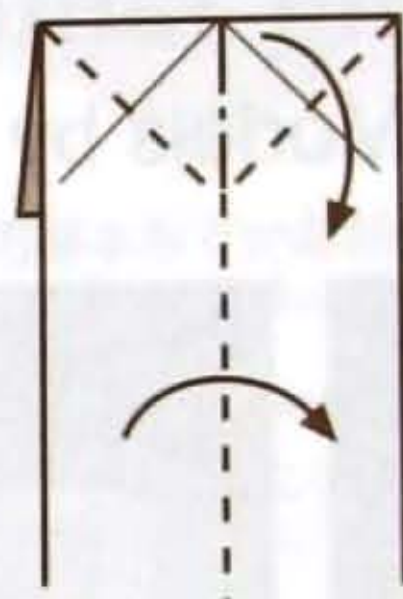

⑥ 平らにたたむ。
Fold into flat.

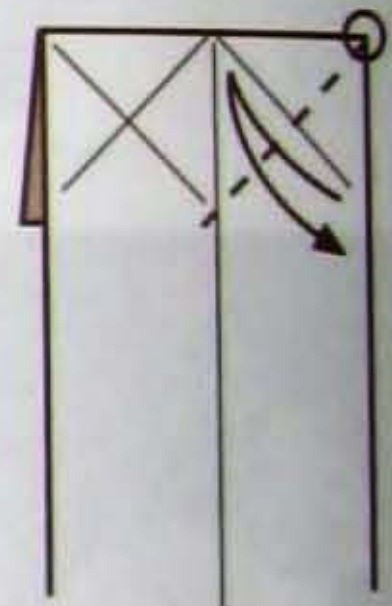

⑤ 1枚だけ折る
Fold only the
upper layer and
unfold.



向きを変える
Turn the model.

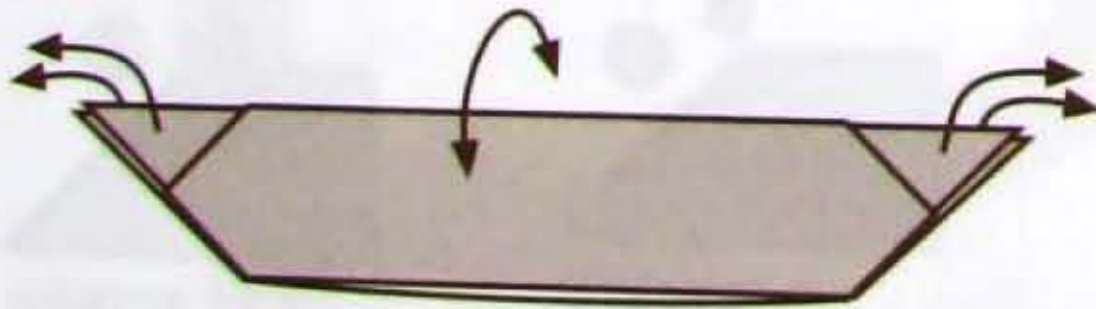

⑨ 4枚のカドを引き下げながら胴体
の部分を筒状にふくらませる。
Pull the four flaps down, and make a tube.



⑪ 折り込んだカドを4つとも引き出す。
胴体部分をつぶさないように注意。
Unfold the four corners. Don't squash
the tube.



⑩



向きを変える
Turn the model.

組み方



① 手差
Tuck
the



⑤ 残り
同様
Tuck
the

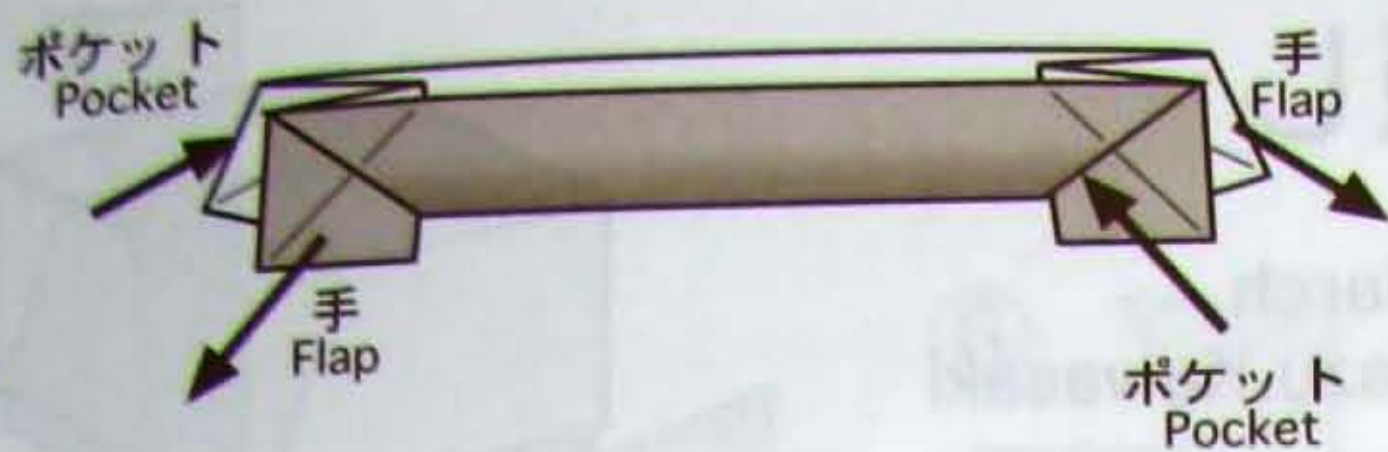

「ポリロッド」のユニット
The POLYROD module
同じものを 12 枚作ります。
You need 12 modules.

組み方 / Assembly

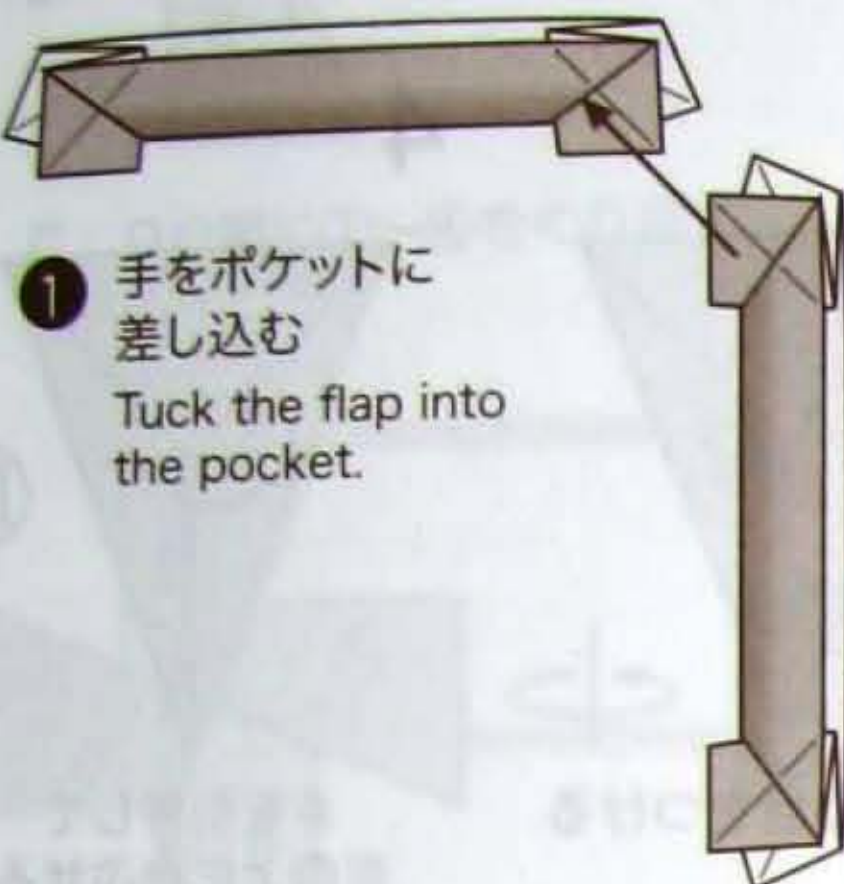

① 手をポケットに差し込む
Tuck the flap into the pocket.

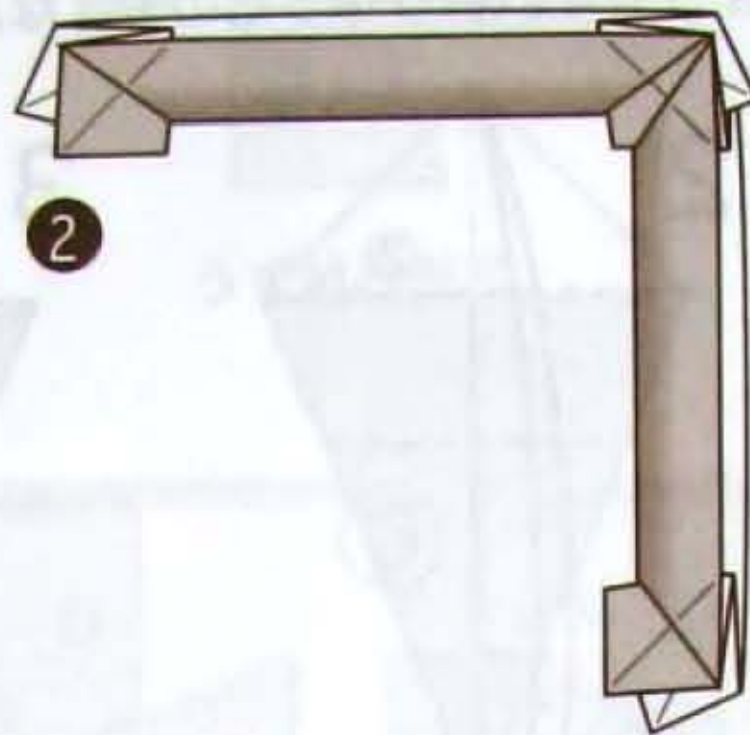

②

こちらから見た図
View from here.

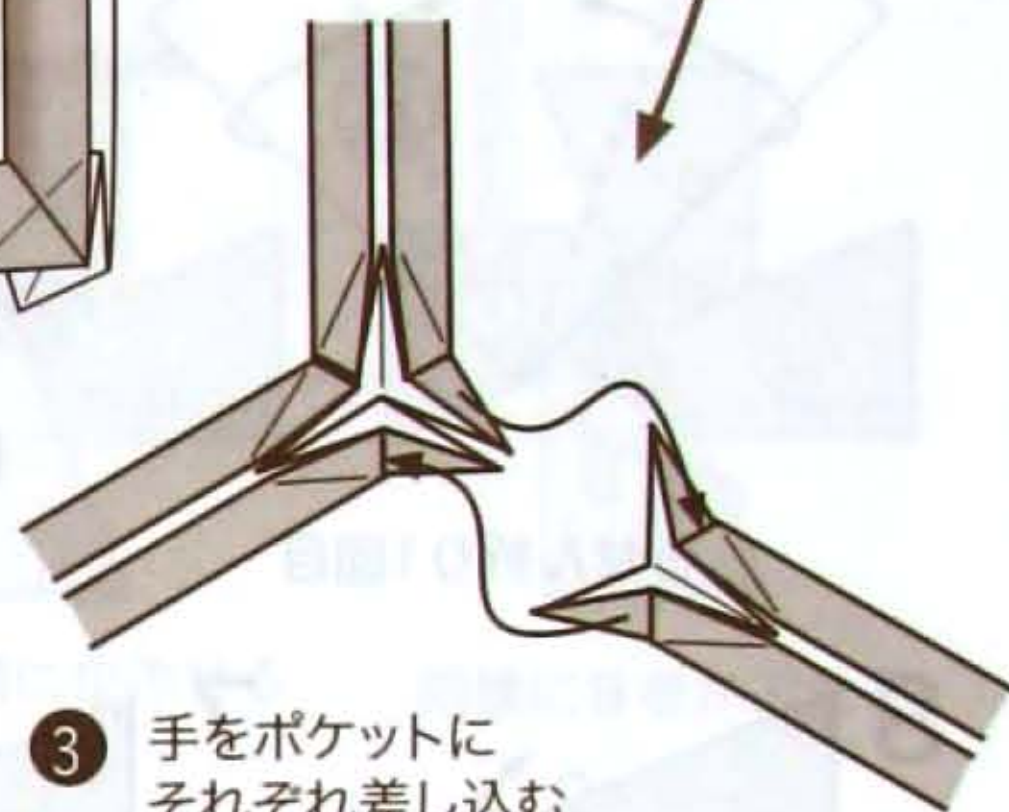

③ 手をポケットにそれぞれ差し込む
Tuck the flaps into the pockets.

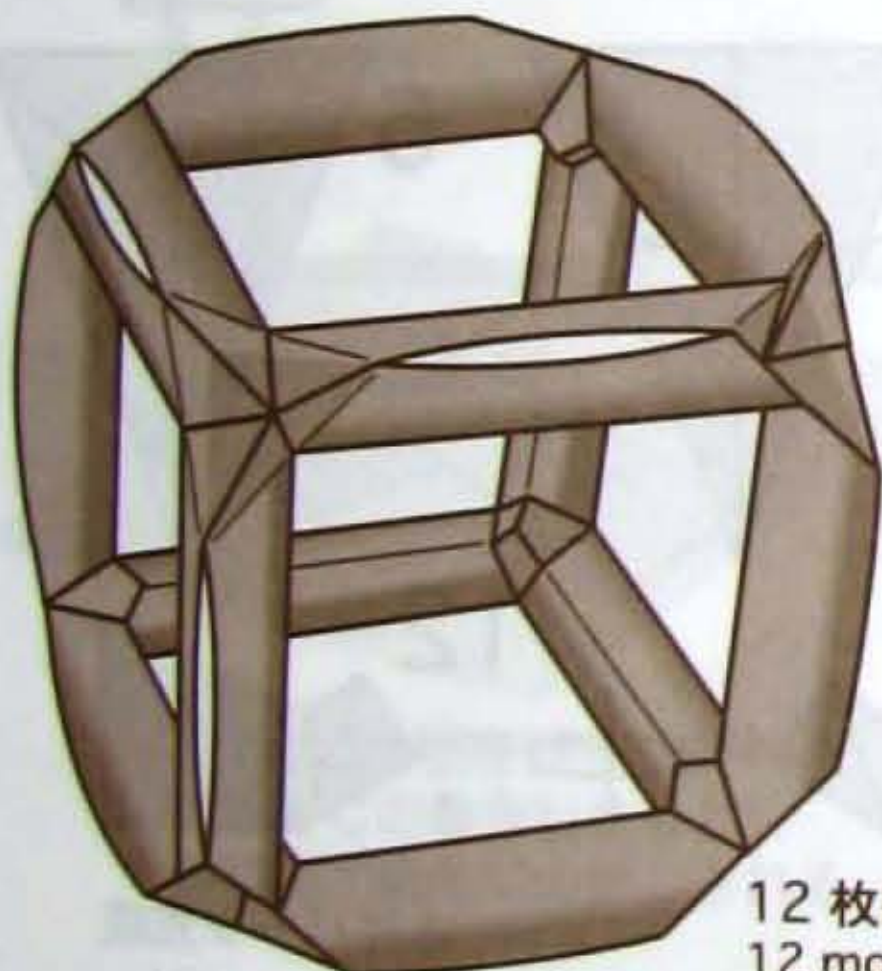

12 枚組
12 modules

※ 6 枚では組めません
Model with 6 modules is impossible to make.

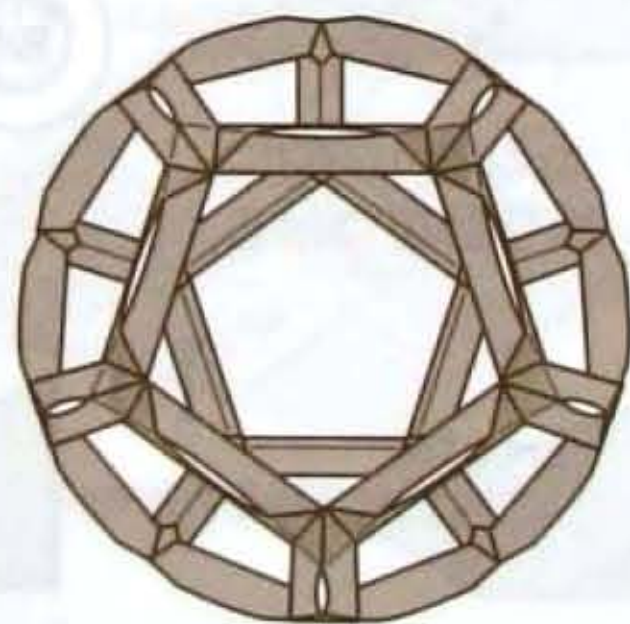

30 枚組
30 modules

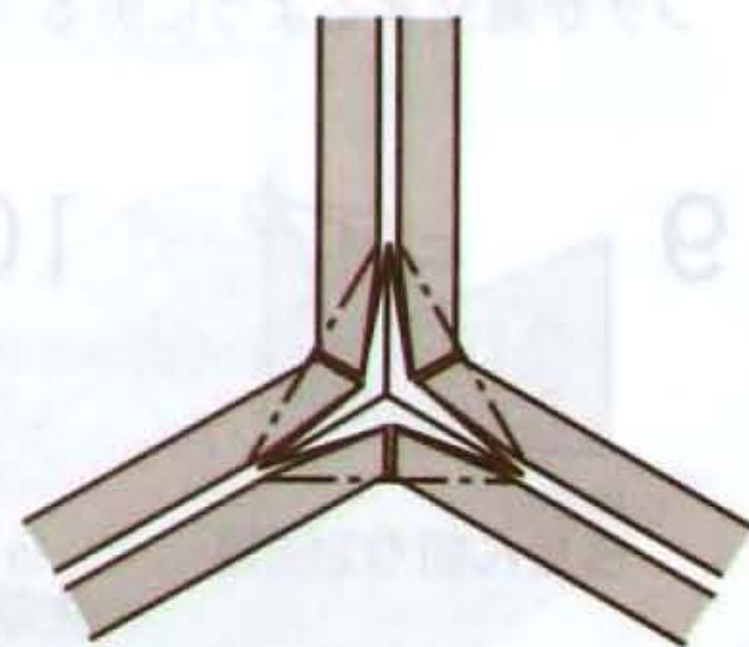

④ 3つのカドを中に折り込む。
Fold the three corners to inside down.



見る向きを変える
Turn the view point.

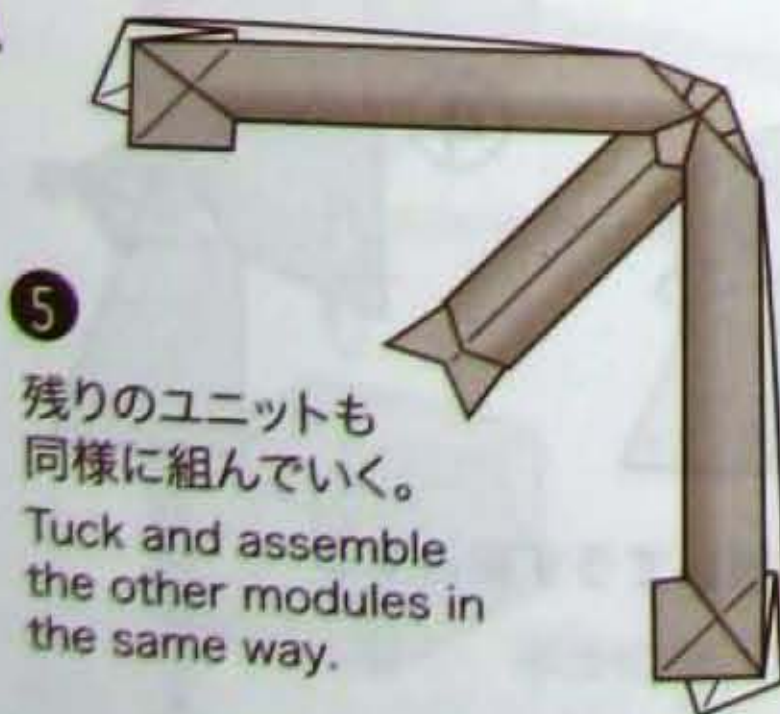

⑤ 残りのユニットも同様に組んでいく。
Tuck and assemble the other modules in the same way.

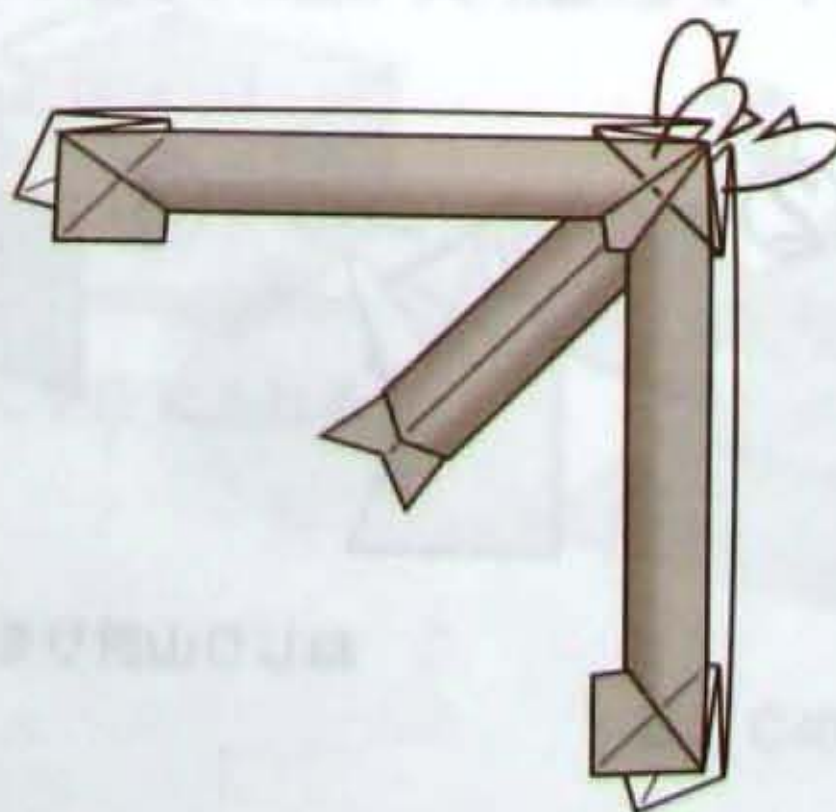

四角深箱うず隠し

川崎敏和 作・作図 2011 March
 Cube Box Elegant by Toshikazu Kawasaki

2011年の新作一押し自信作です。折ればわかるこの快感!

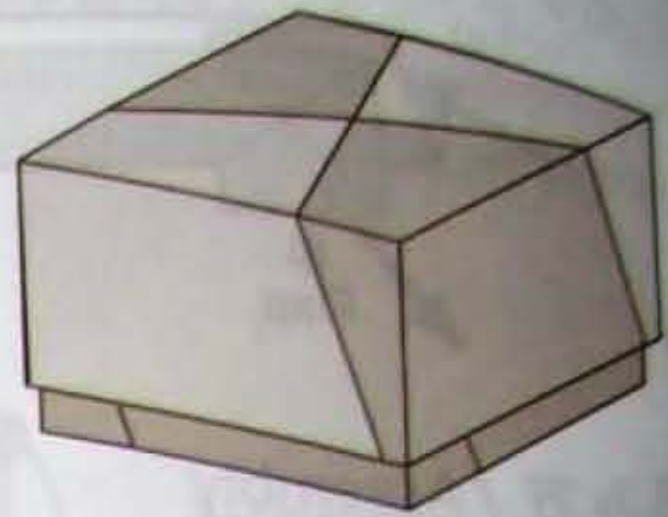

本体パーツを4個作る

わかりやすい折り作ったので、なんとなく覚えられます。

1 らせん折り1回目

2 番号順に折る

3 短い折り目をつける

4 #を引きして※の上にかぶせる

5

6 90°

7 ななめ45度に折り目をつける

8 フチが直角するように折る

9 らせん折り2回目

10 らせん折り3回したあと先端を裏に回してうず留め

11

12 本体パーツ完成

ふたパーツを4個組む

パーツを4個作り、3個のうず留めをほどいておく。

① AにBを差しこんでからBをねじり山折りする

②

③

④

ねじり山折りをくり返してうず組みする

Japão Burajirujin

www.japaoburajirujin.blogspot.com



⑦~⑩をうず隠しという

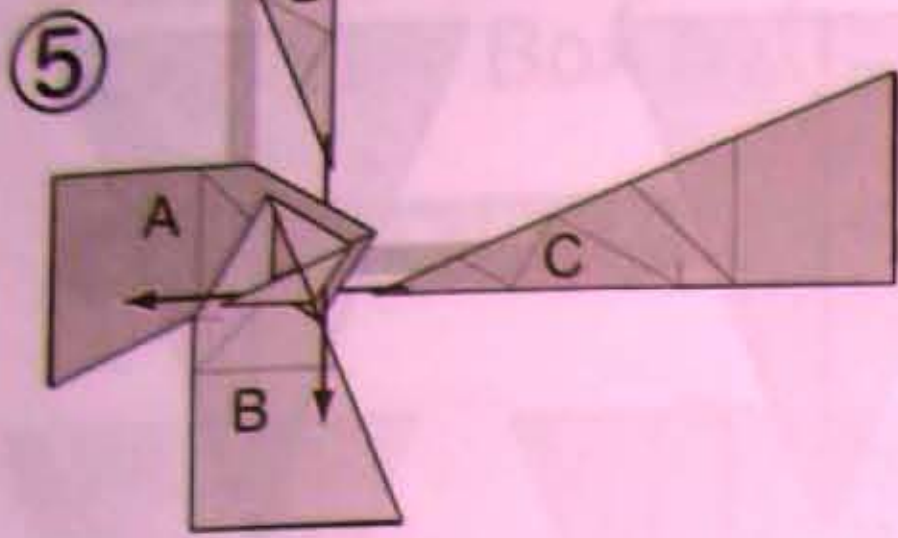

⑤ C、Dの順に①~④をくり返す

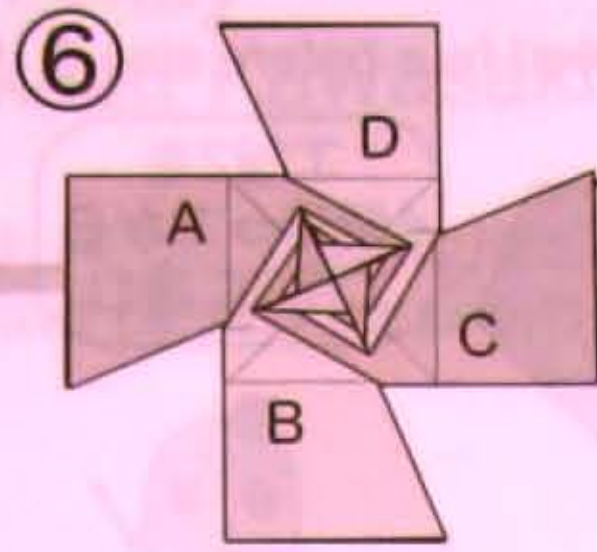

⑥ うず組み完了

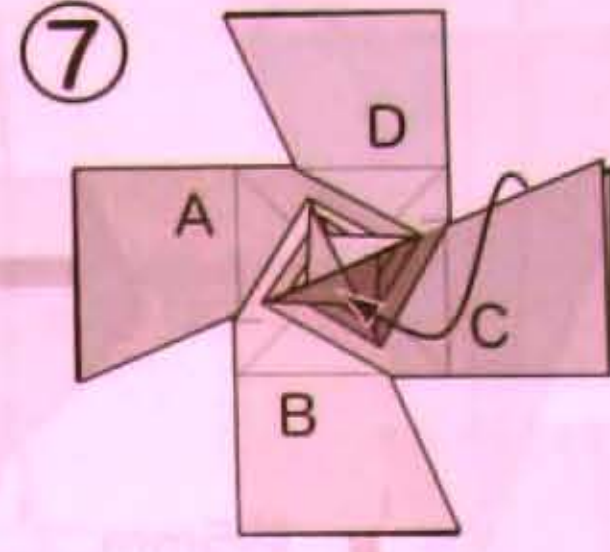

⑦ Cの上1枚を濃い部分にかぶせる

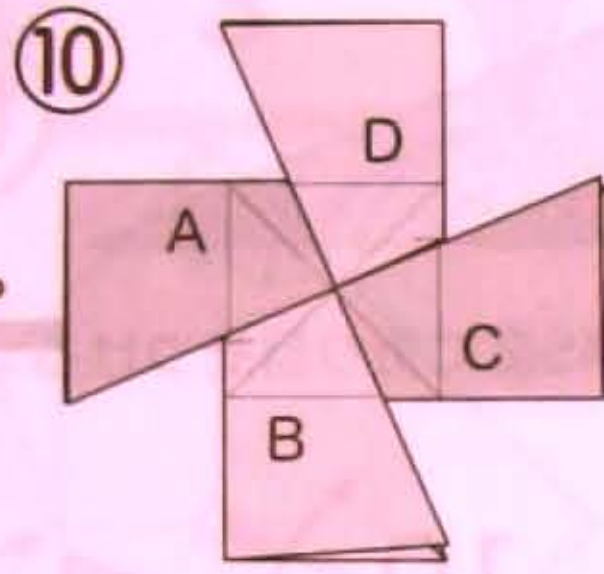
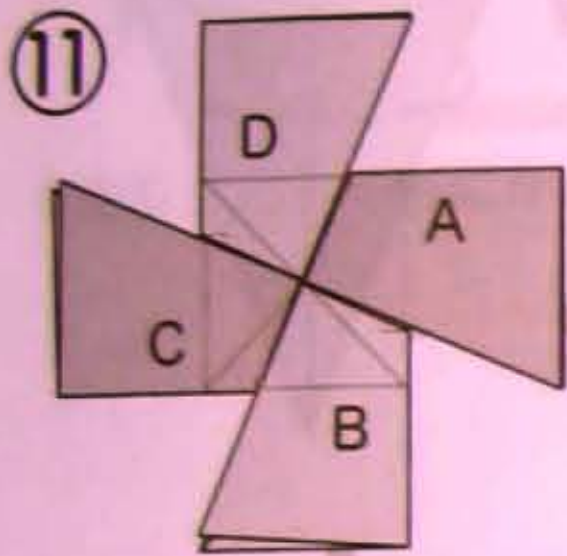

⑩ うず隠し完了

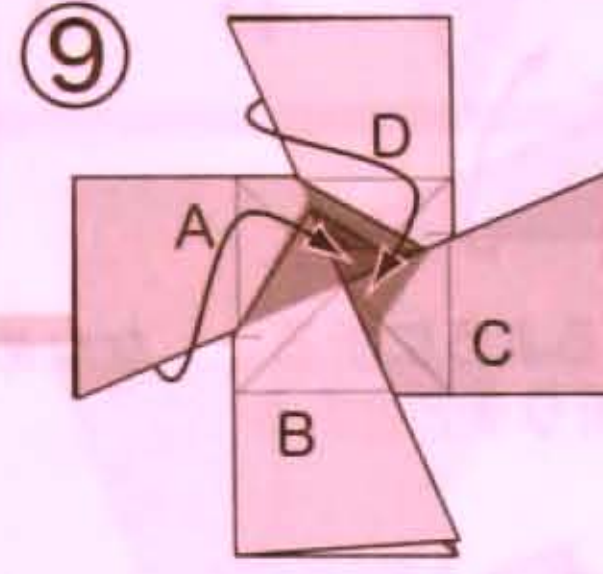

⑨ A、Dの順にかぶせる

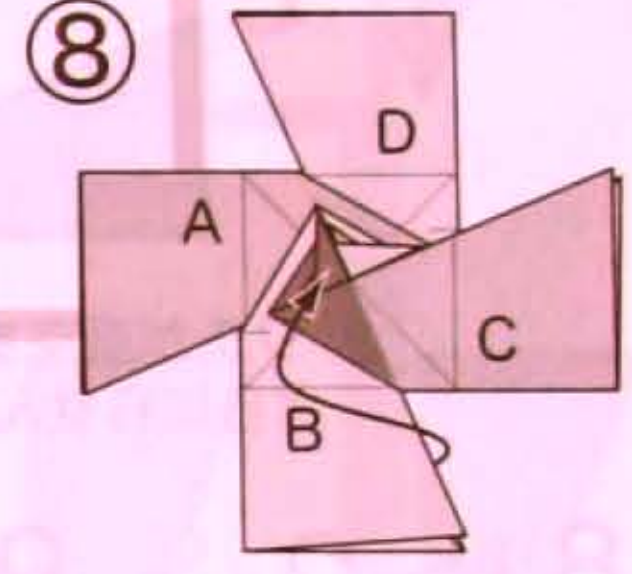

⑧ 同様にBをかぶせる

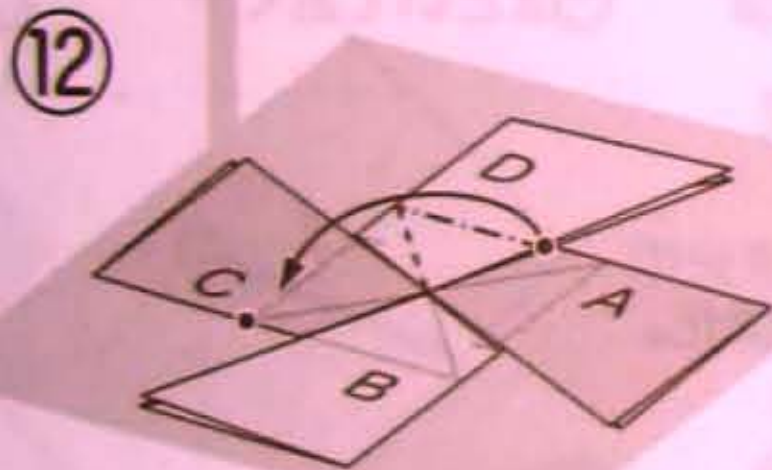

⑫ Dの上1枚をひらいて●をCの●合わせると一点鎖線が直角に山折りされる

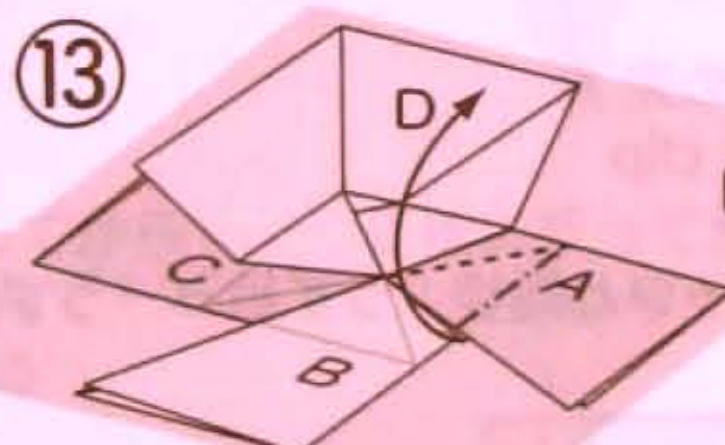

⑬同様に起こす

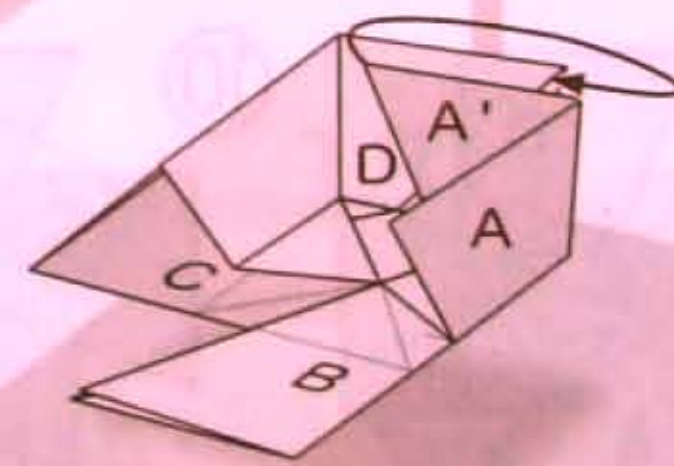

⑭ Dのすき間にA'を入れる

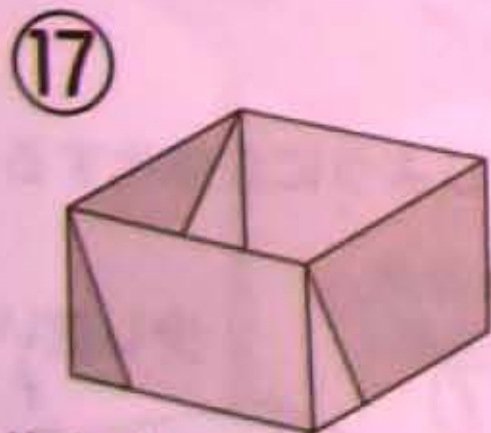

⑰ 本体完成

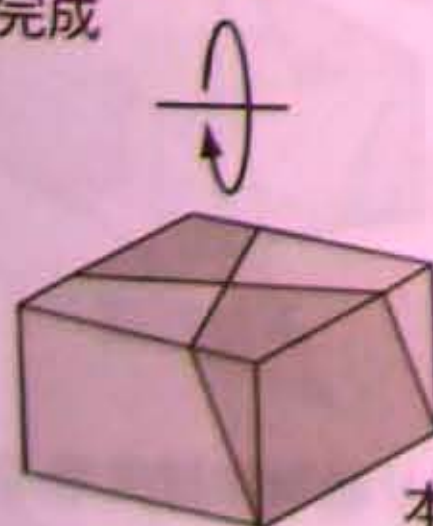

⑰ 本体の底

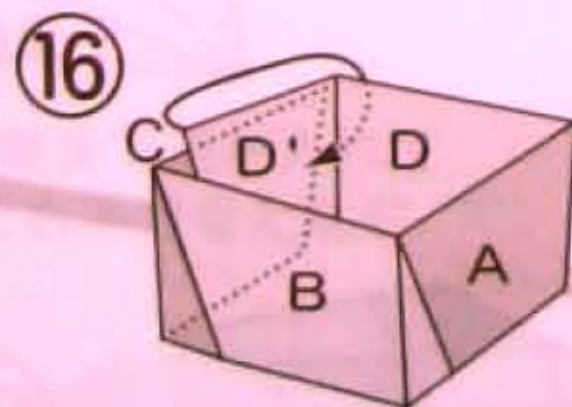

⑯ CをD'に入れる

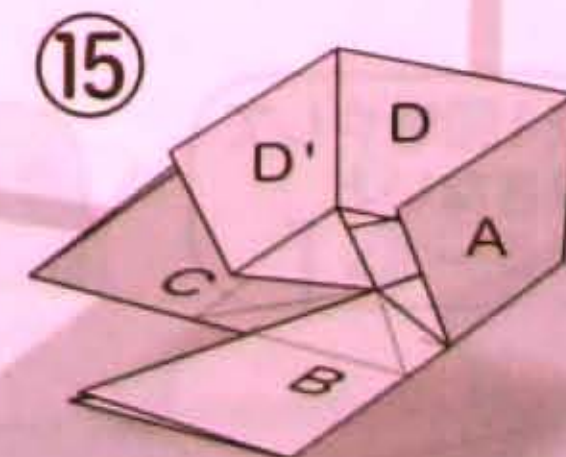

⑮ B、Cの順に⑭⑮をくり返す

ふたパーツを4個作る

本体パーツを少しずらして折るだけです。

1 カドを少しずらして折る

2 We need four before step 3.
工程2を4個作ってから工程3に進む

3 ※の下、#の上折る

4 折り目をつける

5 90°

6 ななめ45度に折り目をつける

7 フチが直角するように折る
さらにらせん折りを2回する

8 先端を裏に回す

9 うず留め完了
Eddy clip

10 パーツ完成

本体の場合同様に4個のうち3個のうずをほどいておく

ふたパーツを4個組む

本体パーツと同じ：うず組み→うず隠し→立体化。

6 うず組み完了

10 うず隠し完了

12 本体⑫と同じように立体化する

17 少し空いている
ふた完成

らせん折りを1回増やしてうずを隠さないと目が回る～!

© 折り紙科学研究所 2011
無断複写禁止

四つ星の箱

Japão Burajirujin

www.japaoburajirujin.blogspot.com

川崎敏和 作・作図 2011 May
Four-Star Box by Toshikazu Kawasaki

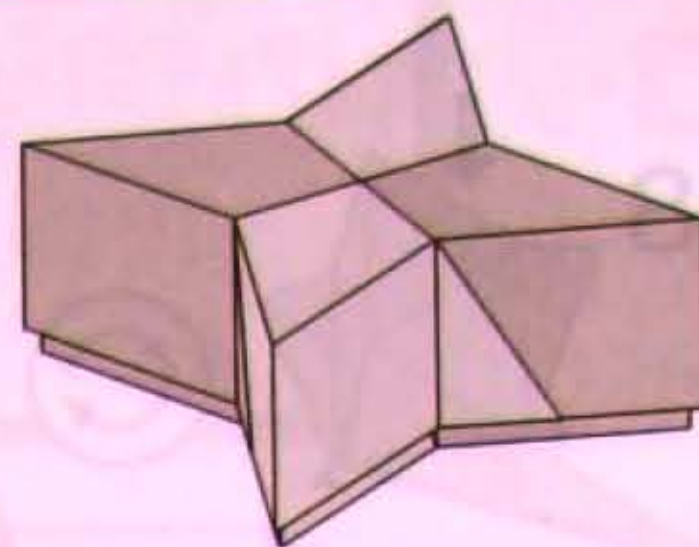

本体星パーツを4個作る

ともちんもびっくり!? 星型の箱です。
Tomo-chin will be also surprised at this Star Box.

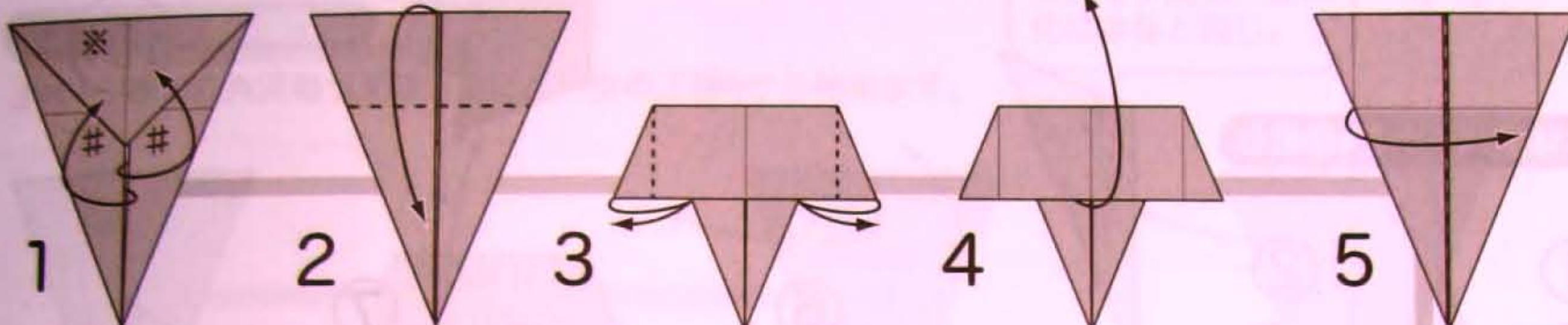

#を引き出して※にかぶせる

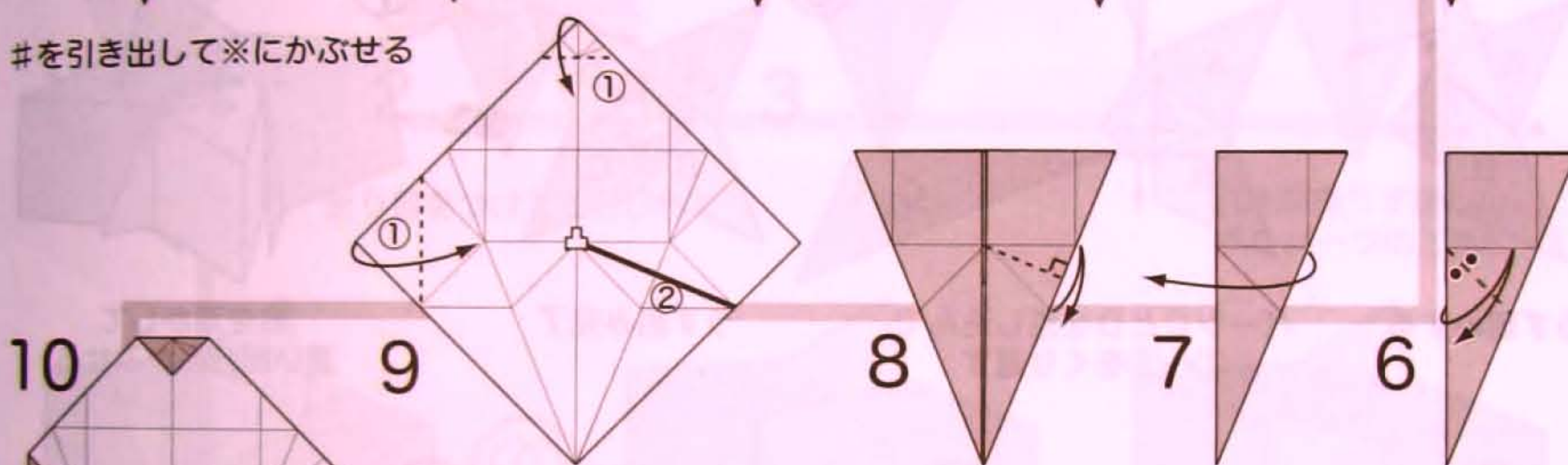

中央を押し出してから
太線をつまんで
山折りする

正確に折ってから
全部ひらく

ひらく

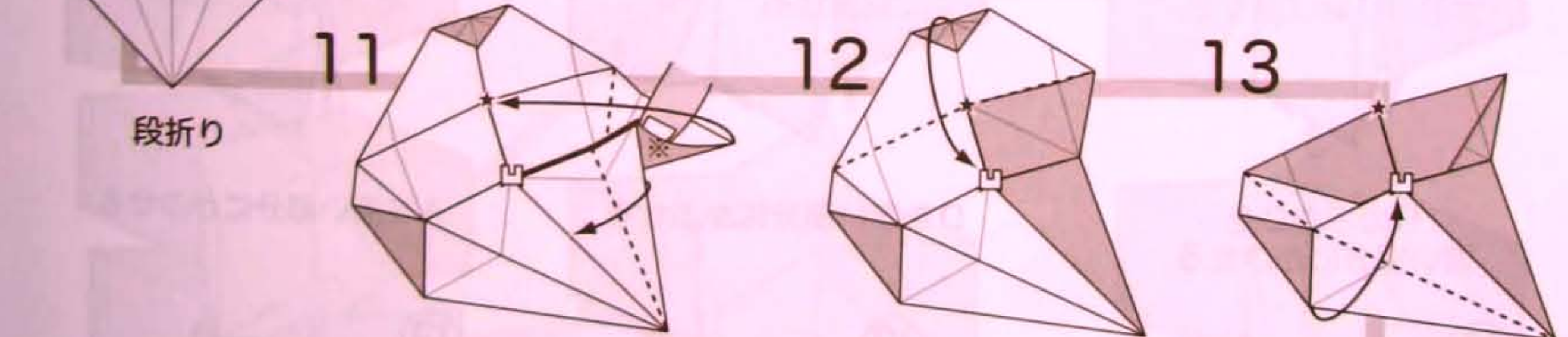

※のくぼみの奥まで指を入れて
★を合わせて右半分をたたむ

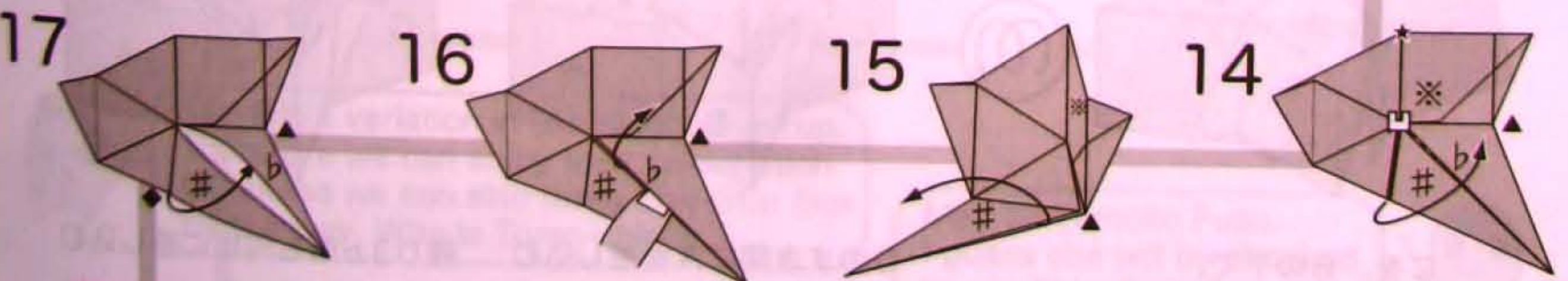

#をbの下に入れて
◆を▲に一致させる

bの奥(▲)まで
指を入れてひろげる

工程14にもどす

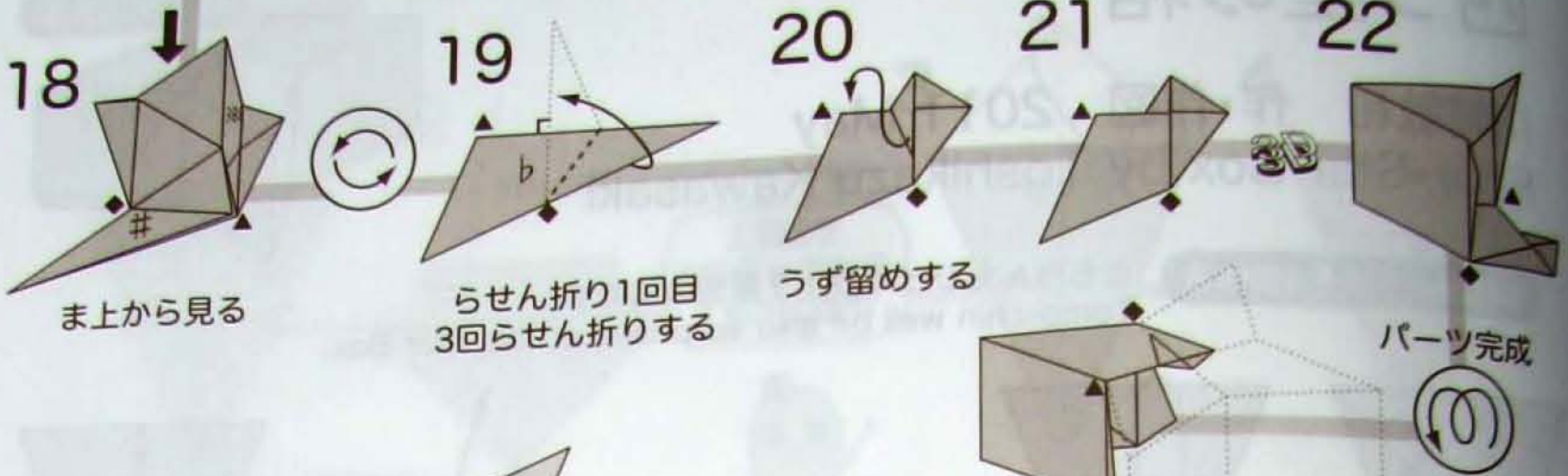

本体星パーツを4個組む

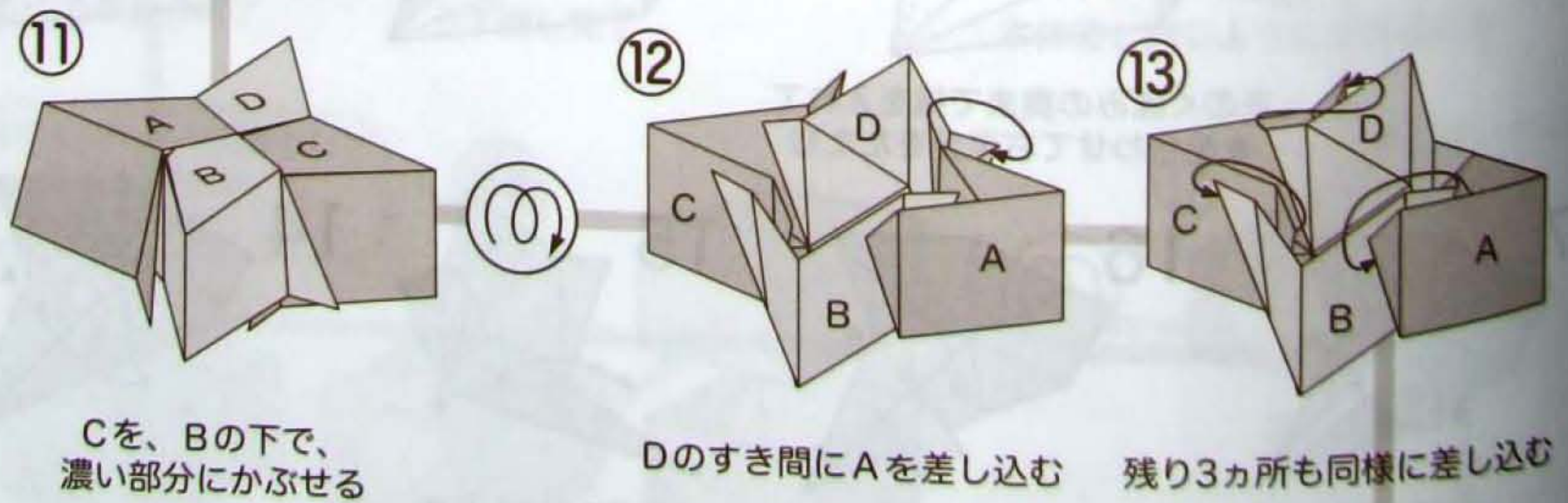
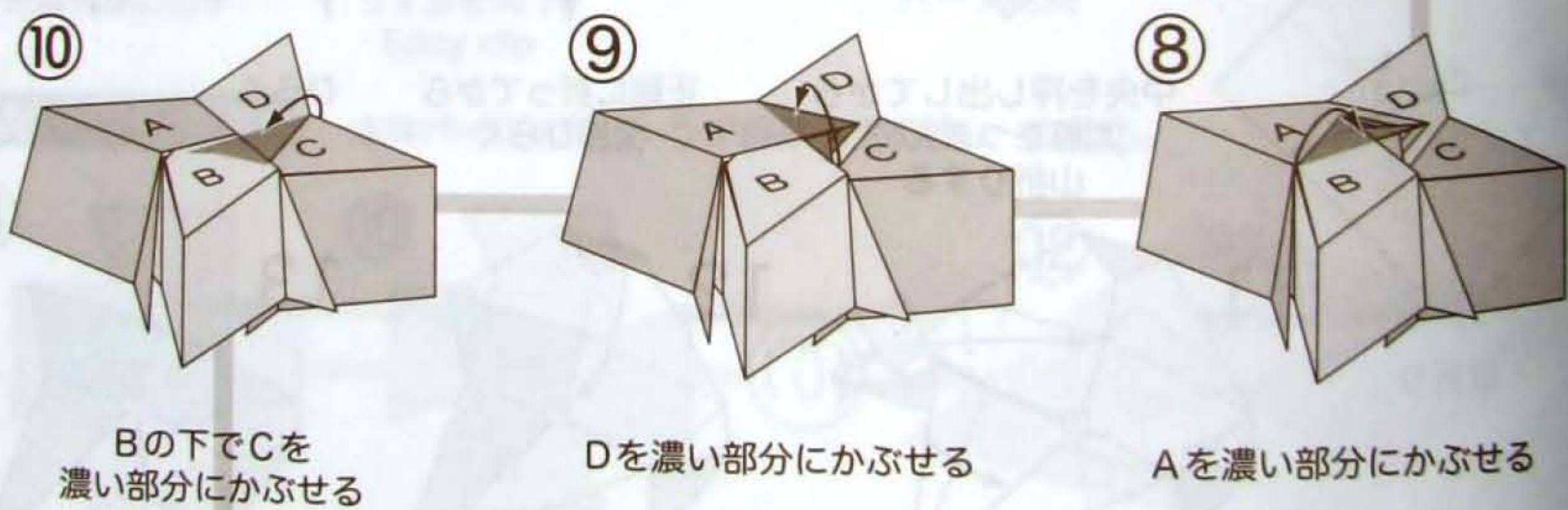
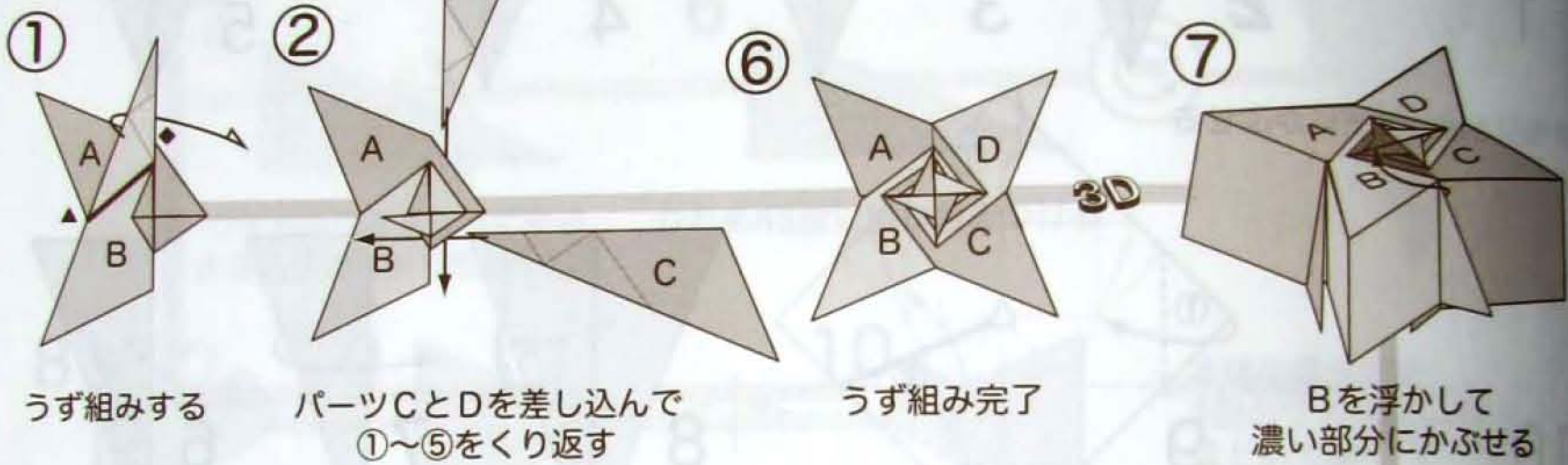

14

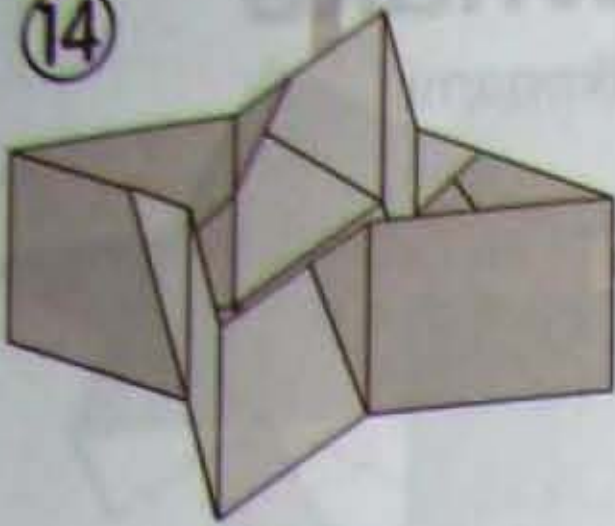

本体完成

15

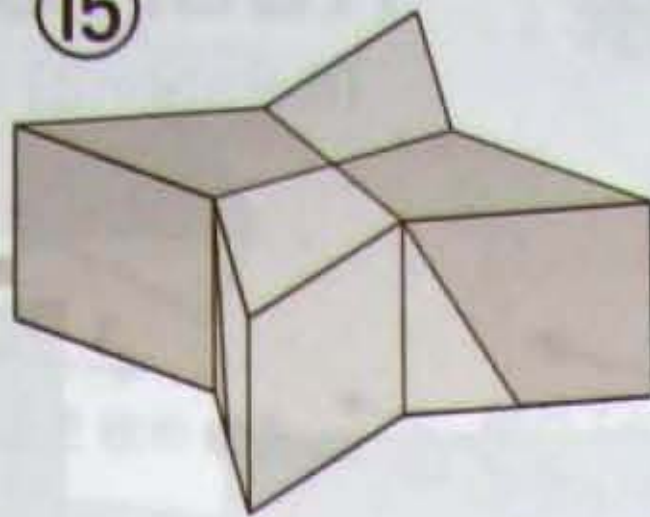

本体の底



折り目の位置が少し違うだけで、ここから先の折り方、組み方、うず隠し、立体化は本体と同じ。



星ふたパーツを4個作る

3ページ前の四角深箱うず隠しふたパーツの工程4から始めます。

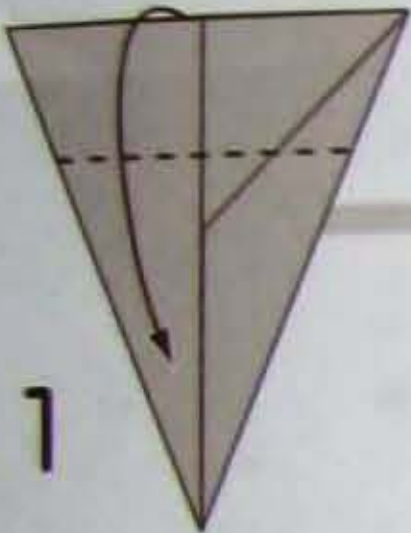

1

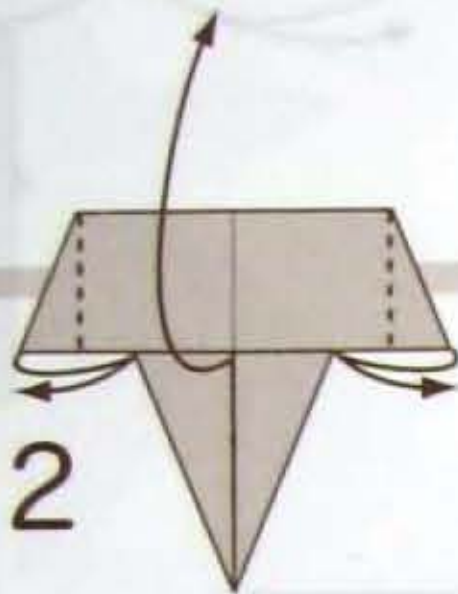

2

折り目をつけてからひらく

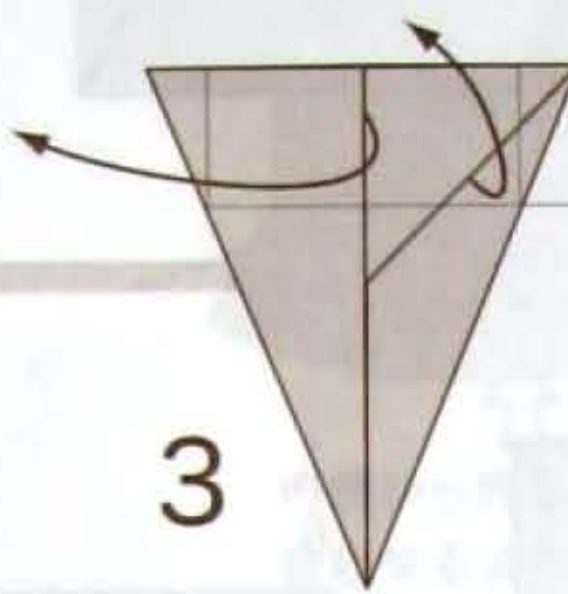

3

ひらく

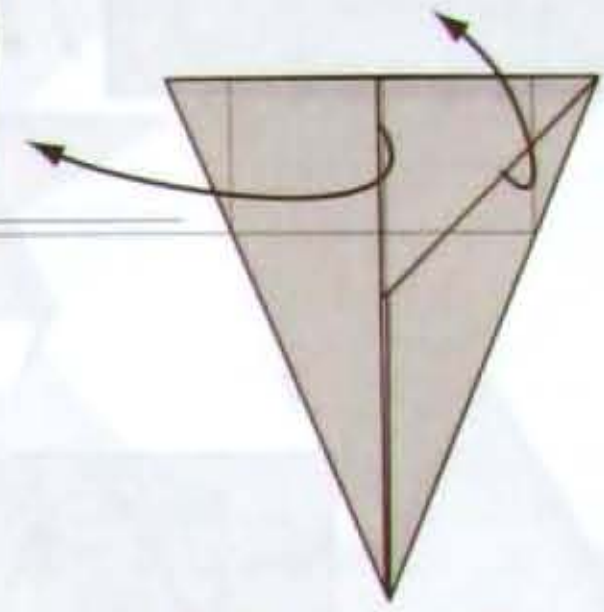

四角深箱うず隠しのふたパーツの工程5

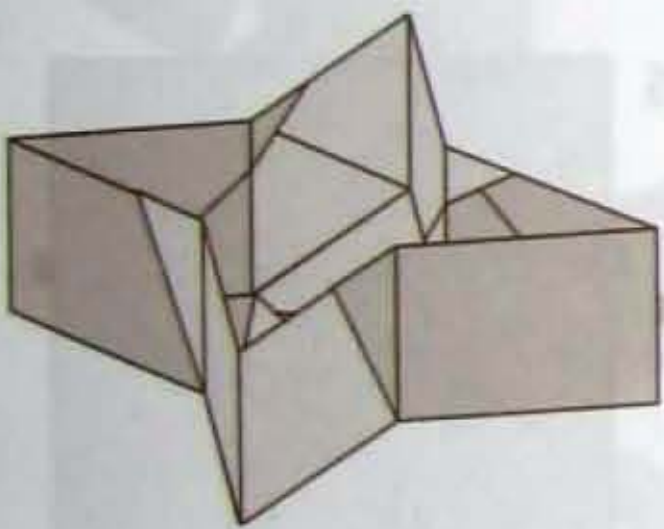

ふたの内側

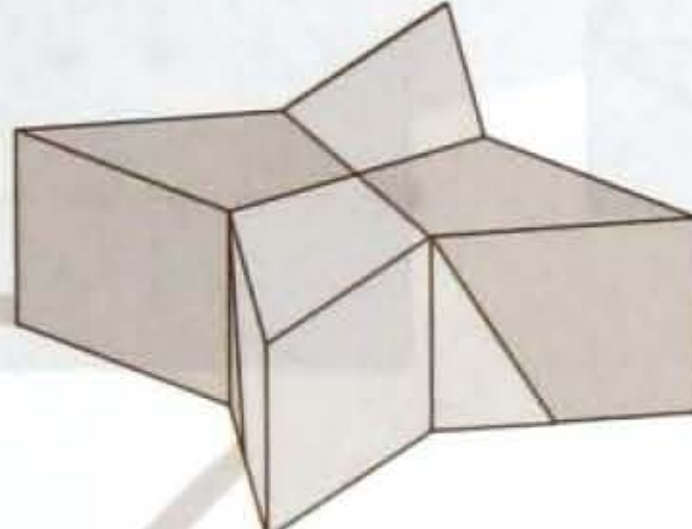

ふた完成

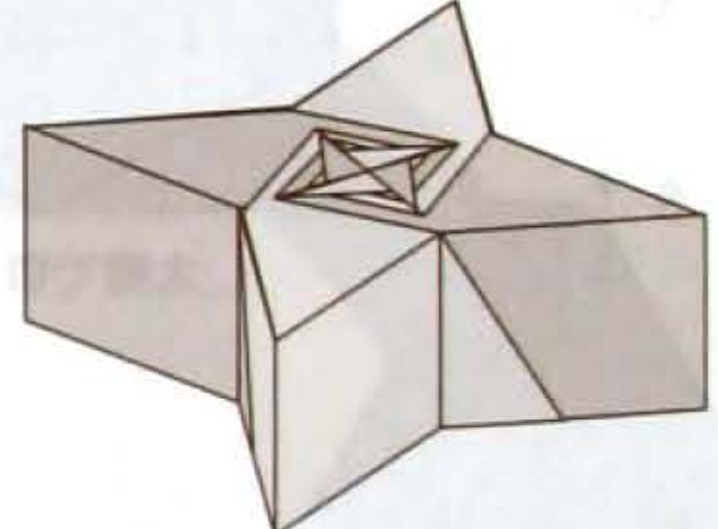

うず隠し無しのふた

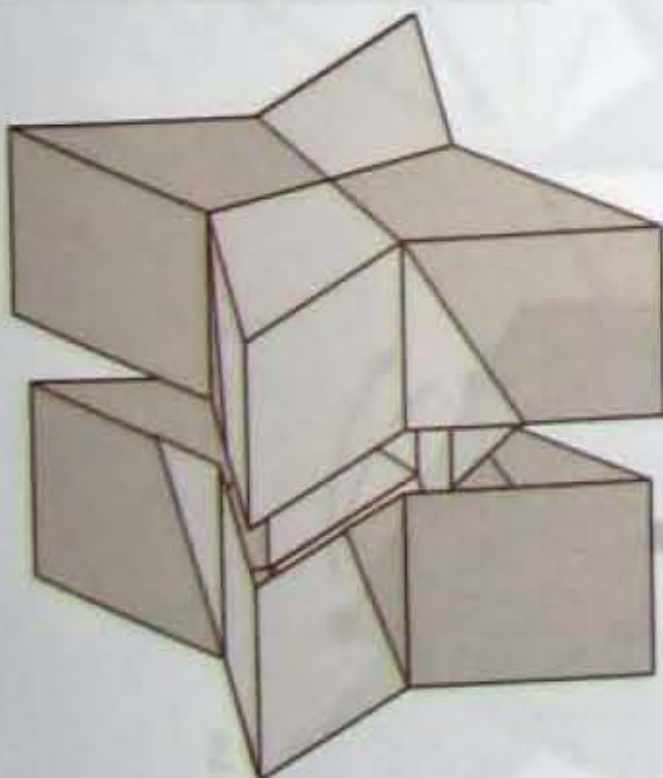

四つ星の箱完成

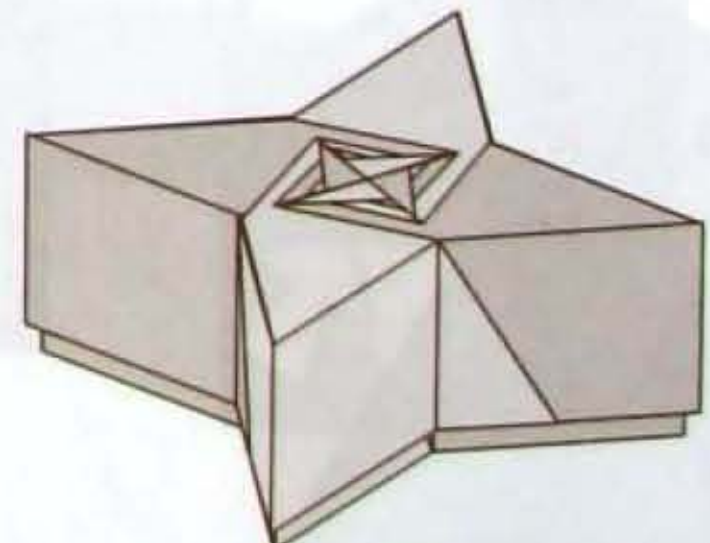
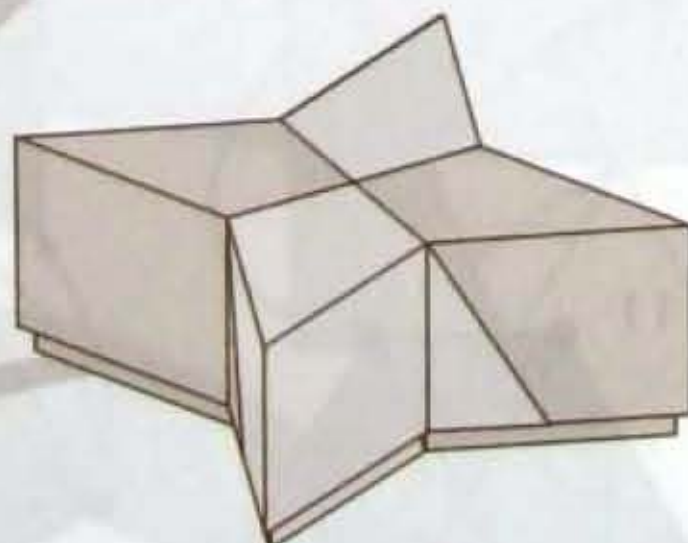

うず四つ星の箱完成



There is a variation in Star-Module gorup. Therefore we can enjoy their combination. Of course we can also make Five-Star Box. By the way, Who is Tomo-chin ?

Maybe Tomoko Fuse. I guess she will be shocked to see Four-Star Box.



コッホの雪片曲線

Koch's Snowflake

(iteration2) by Ushio Ikegami

(繰り返し2回)

作・図 池上牛雄

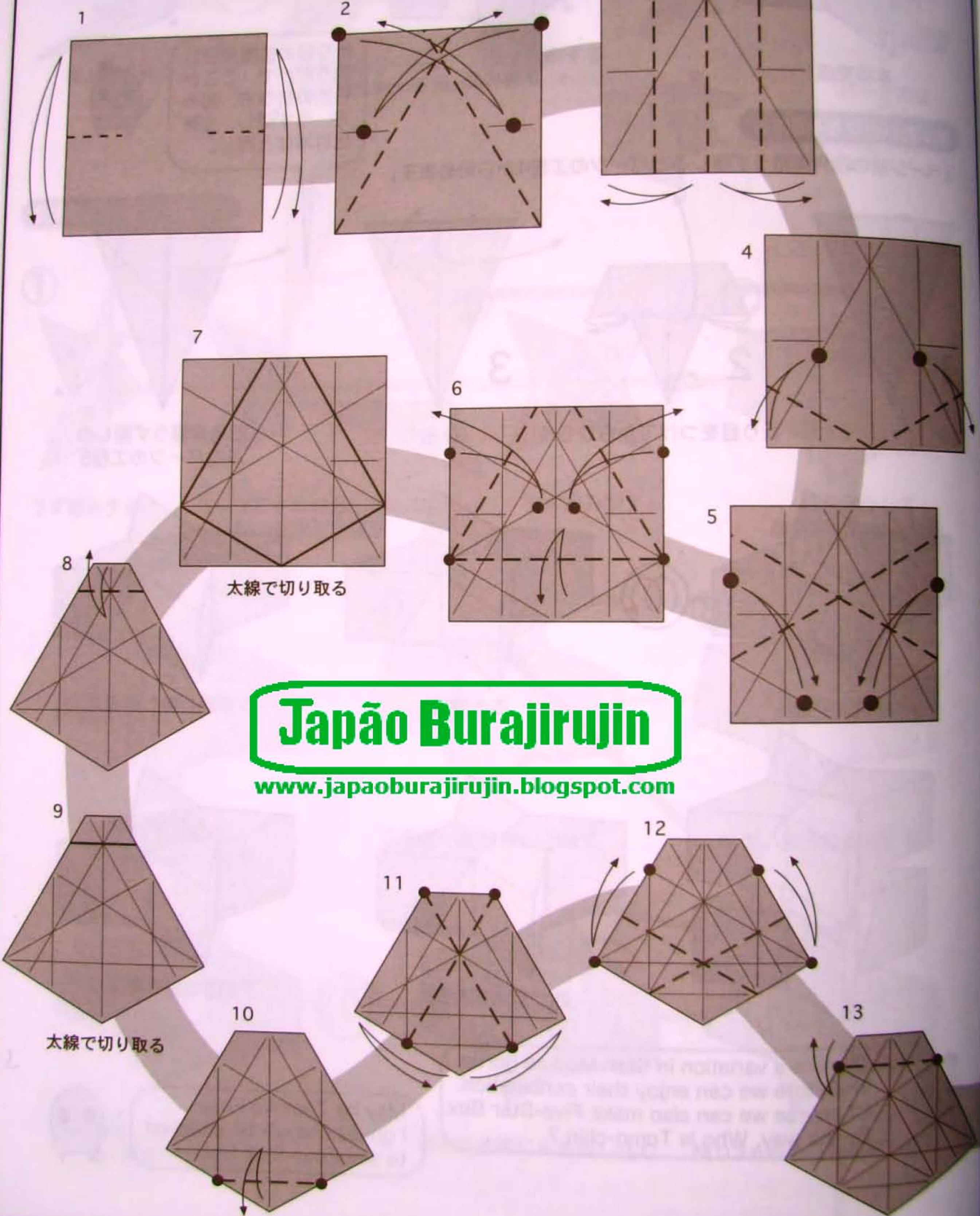

Japão Burajirujin

www.japaoburajirujin.blogspot.com

22

右側も同様

21

20

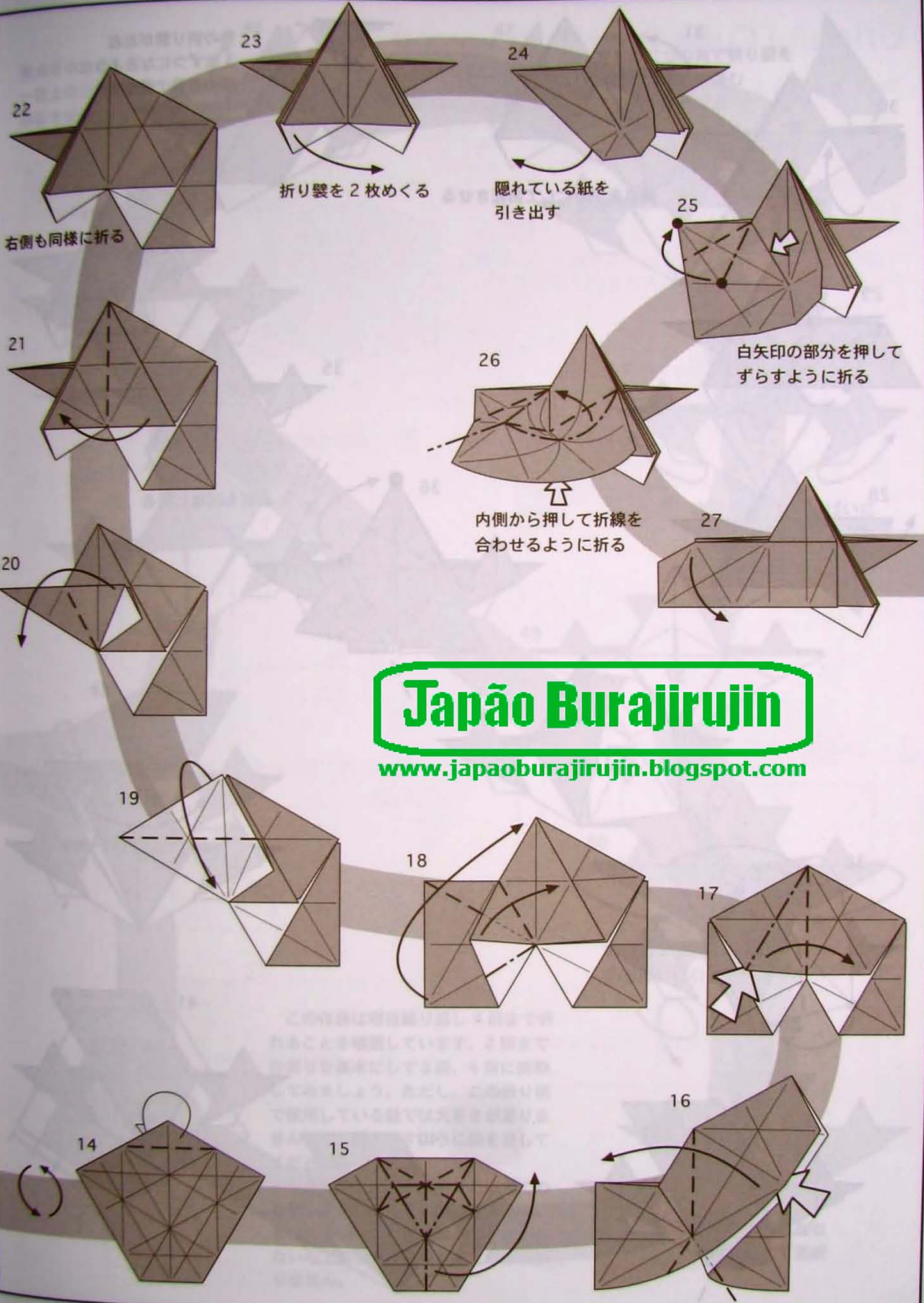

22
右側も同様に折る

23
折り皺を2枚めくる

24
隠れている紙を
引き出す

25
白矢印の部分を押し
ずらすように折る

21

26
内側から押して折線
合わせるように折る

20

27

Japão Burajirujin

www.japaoburajirujin.blogspot.com

19

18

17

14

15

16

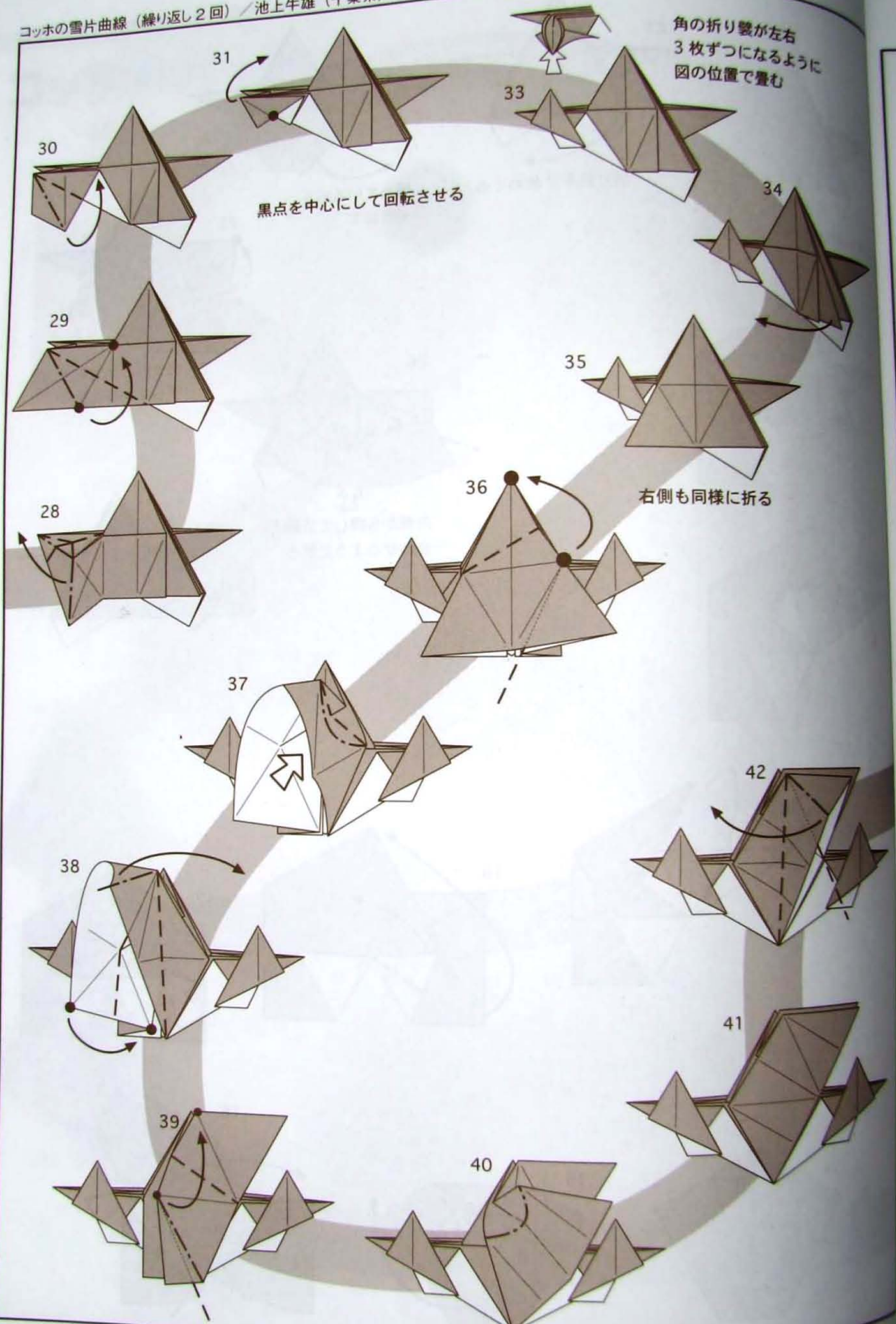

31

30

33

角の折り皺が左右
3枚ずつになるように
図の位置で畳む

黒点を中心にして回転させる

29

34

35

28

右側も同様に折る

36

37

42

38

41

39

40

黒点を中
一番上の
回転させ

第17回折紙

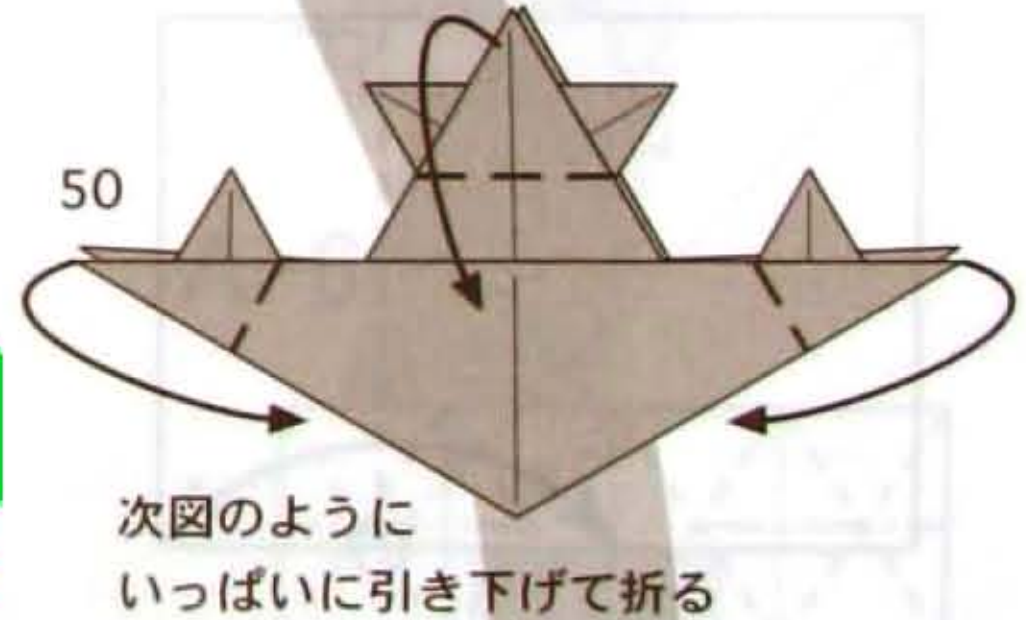
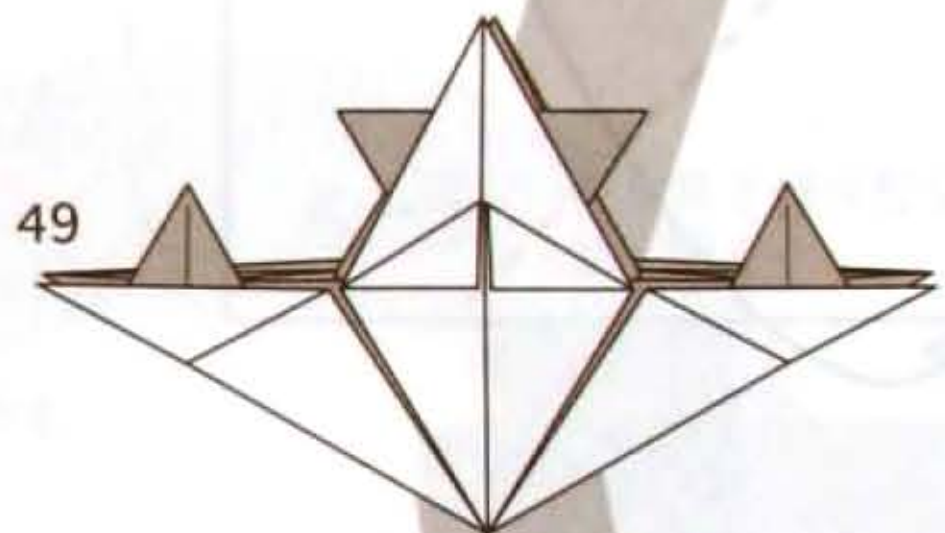
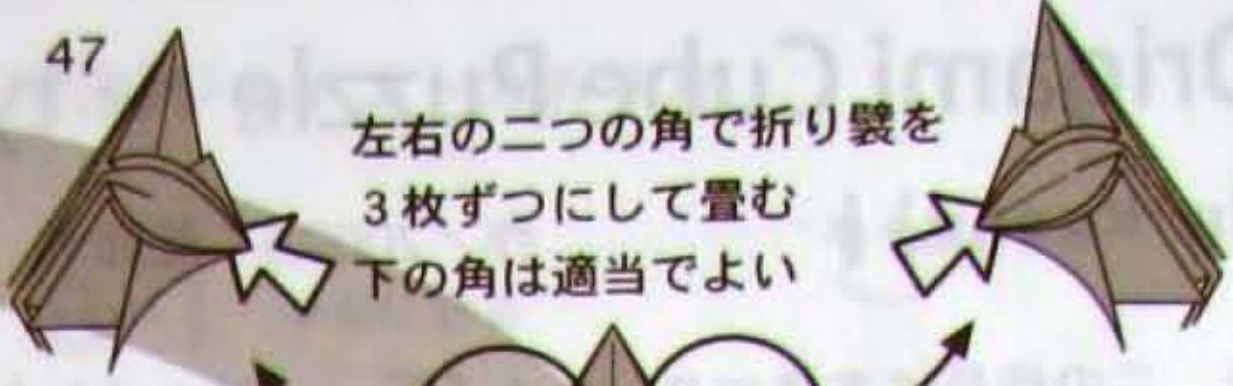
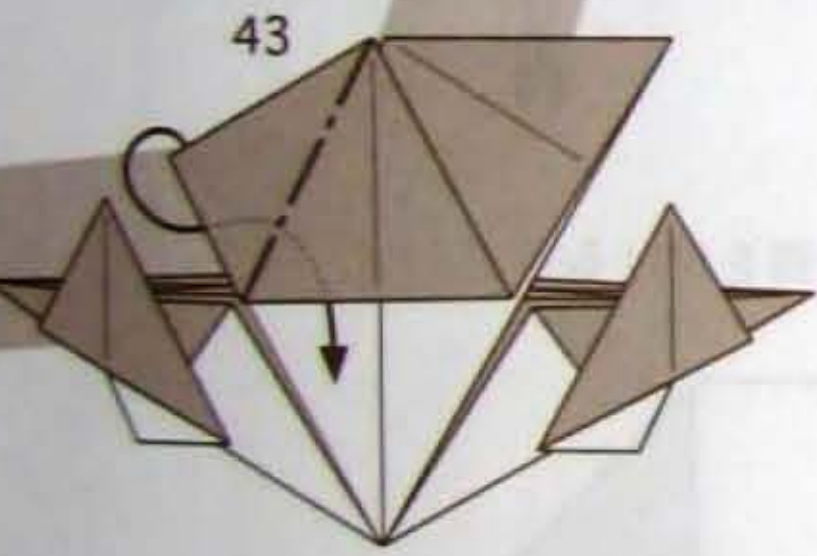
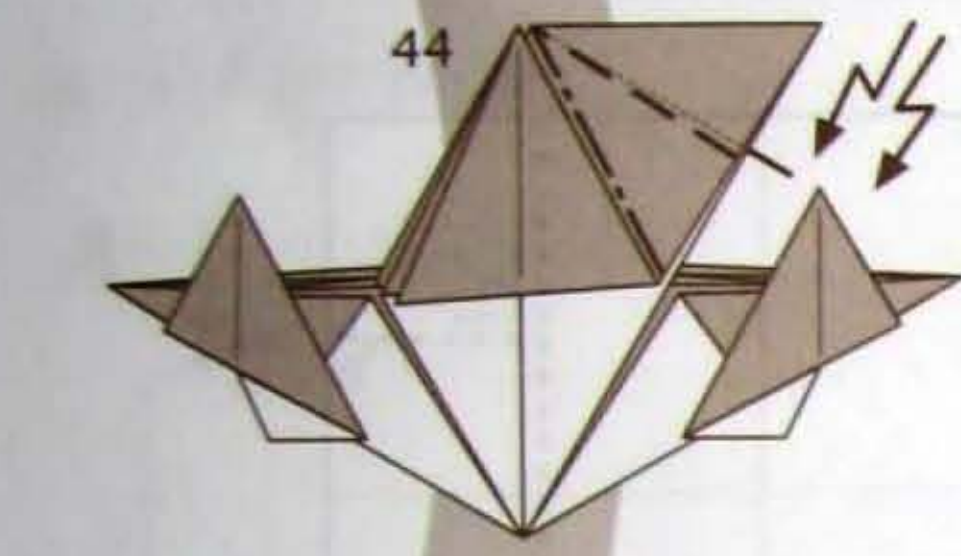
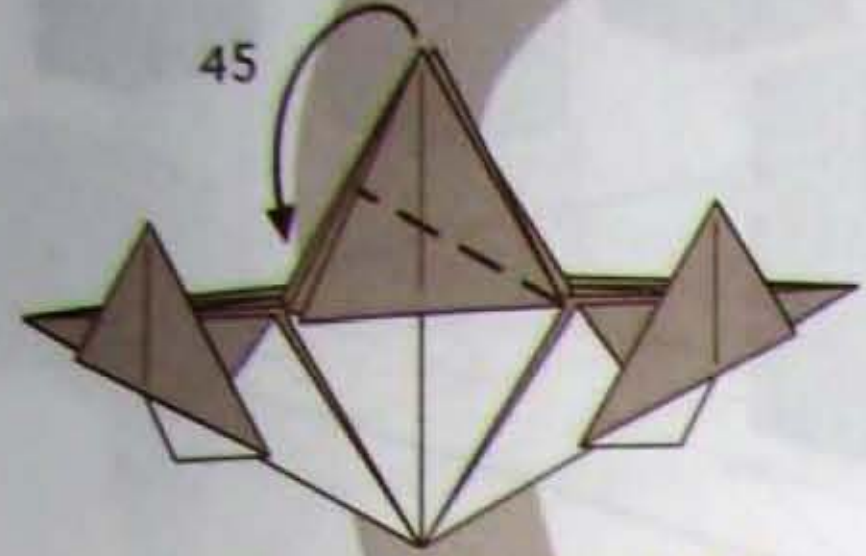
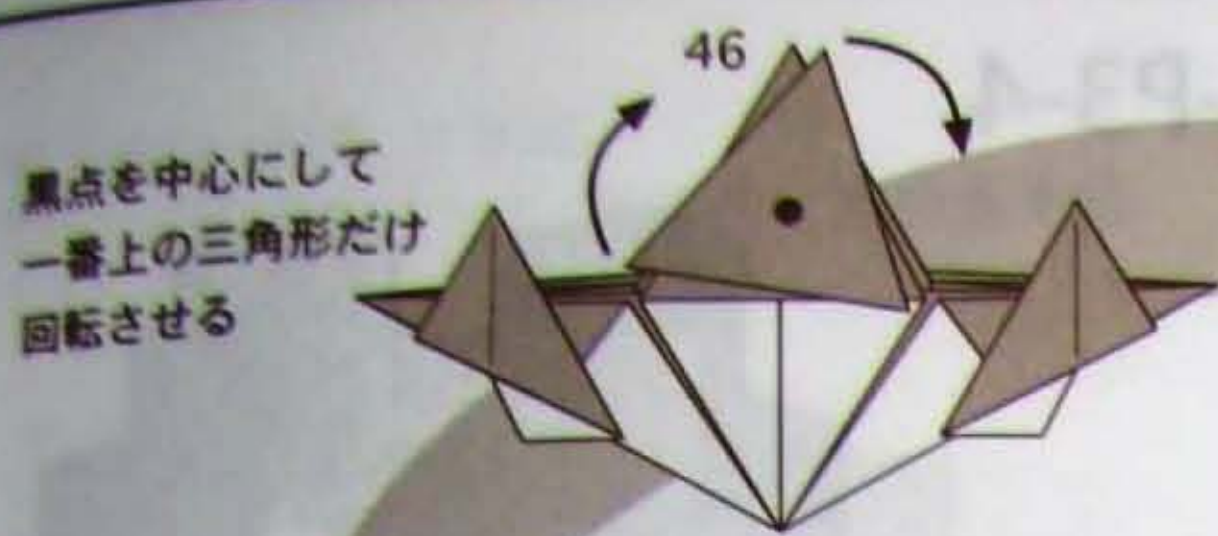

Japão Burajirujin
www.japaoburajirujin.blogspot.com

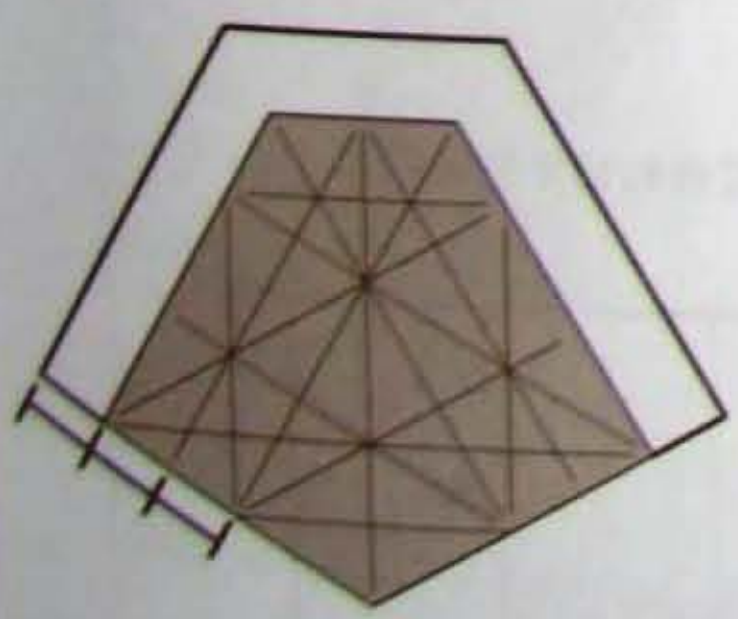

この作品は現在繰り返し4回まで折れることを確認しています。2回までの折りを基本にして3回、4回に挑戦してみましょう。ただし、この折り図で使っている紙では大きさが足りませんので、図に示すように紙を足してください。

ちなみに、設計では折りたい全ての角が上で示した大きい紙に収まっているのですが、角の間の畳み方が分からないので無限折り可能かどうかはわかりません。

Origami Cube Puzzle ~ type-P3-4.

By Kasumioji

作/2009.5 霞誠志

※ この作品は本体 = $2 : 1 + \sqrt{2}$ 、ジョイント = $1 : \sqrt{2}$ の長方形用紙を使っています。別々に用紙を作っても良いですが、ここでは、本体とジョイントの用紙を一枚の長方形から裁断する方法を紹介します。

<推奨サイズ> A5サイズ = 148mm × 210mm から裁断すると出来上がりの大きさが1辺の長さ = 約6cmの立方体になります。

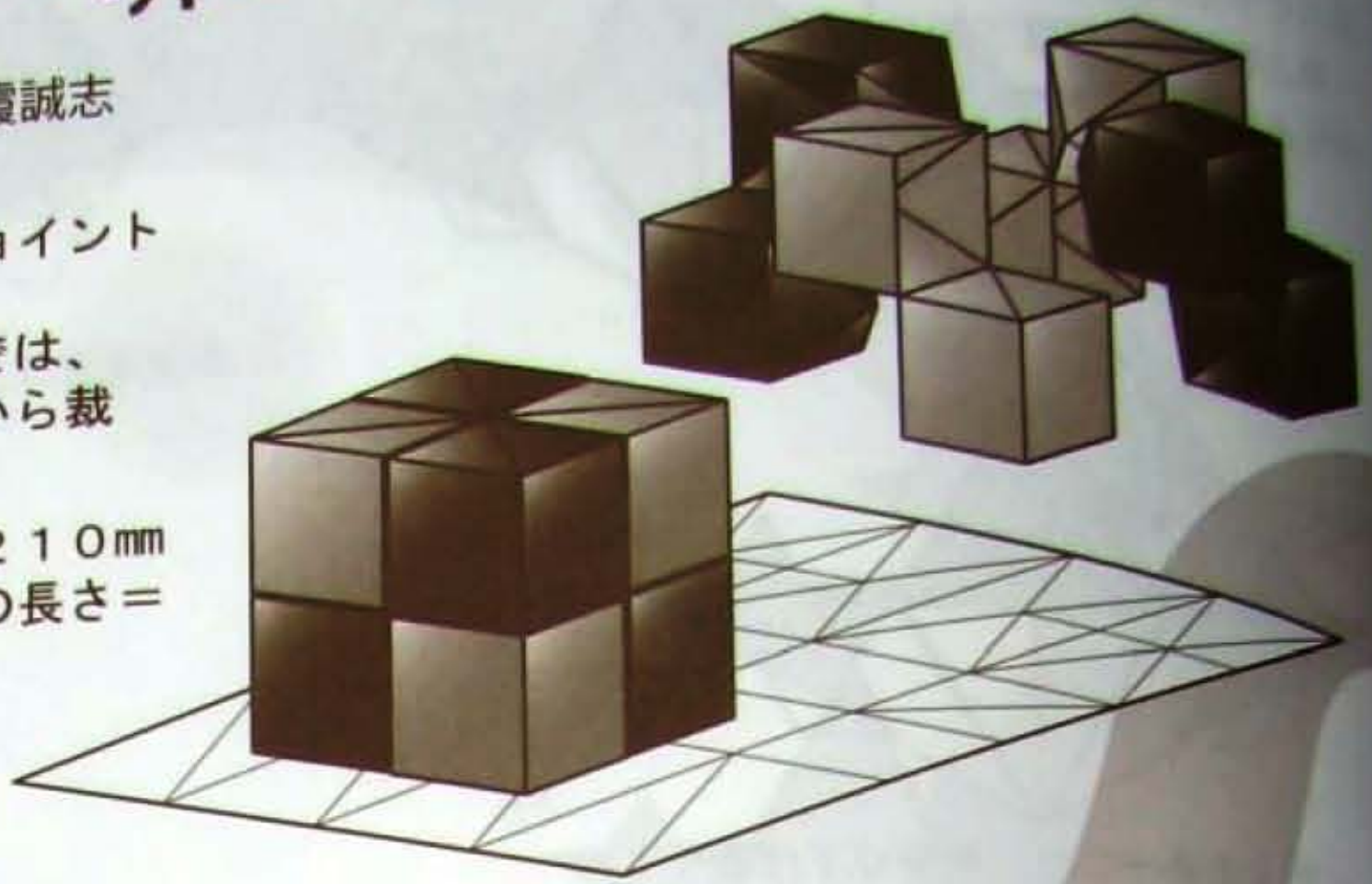

1. $1 : \sqrt{2}$ の長方形を使います
縁を合わせて折り筋を付ける

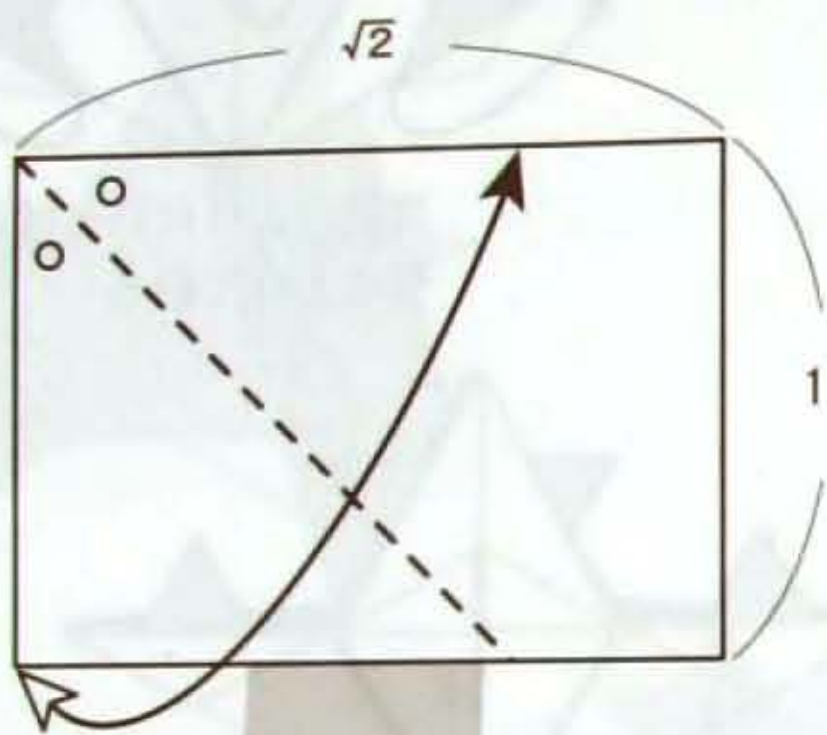

2. O印を通る線で折り筋を付ける

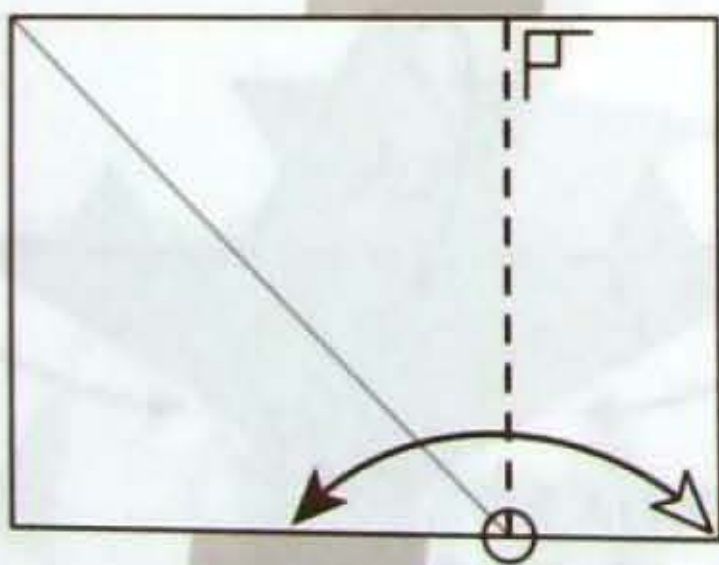

3. [a]と同じ幅の折り筋を付ける

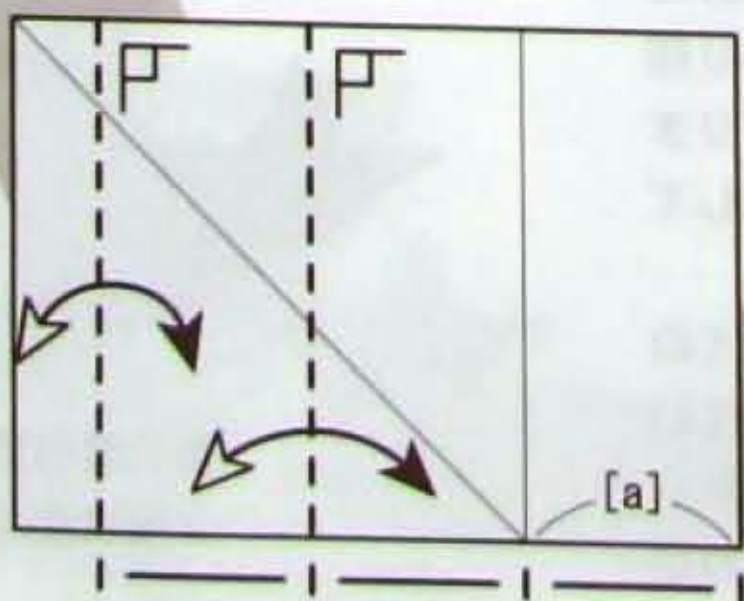

6. 図の位置で切り離す

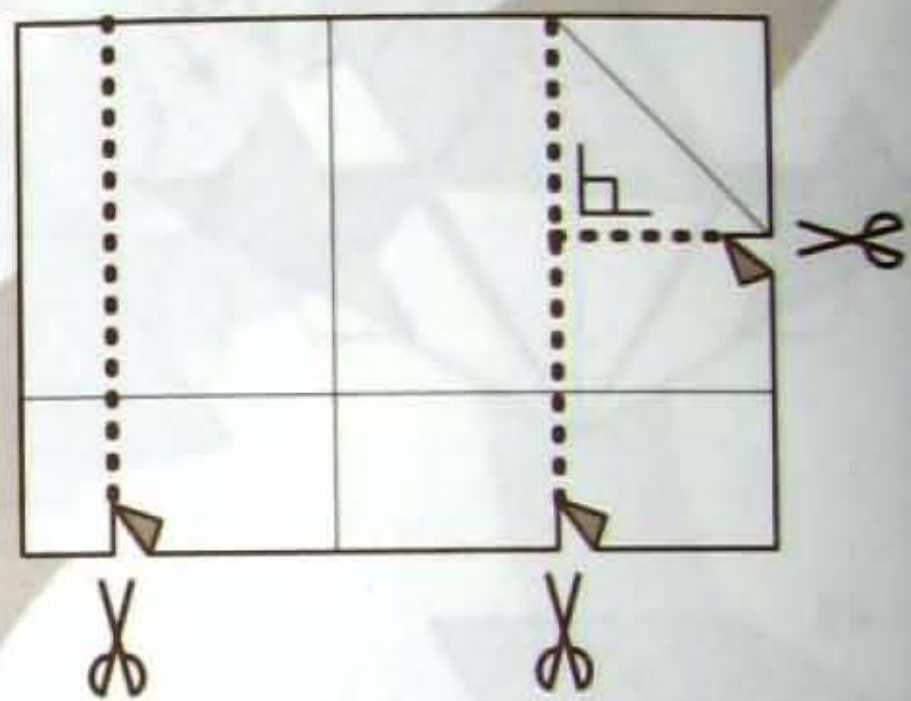

5. 縁を合わせて折り筋を付ける

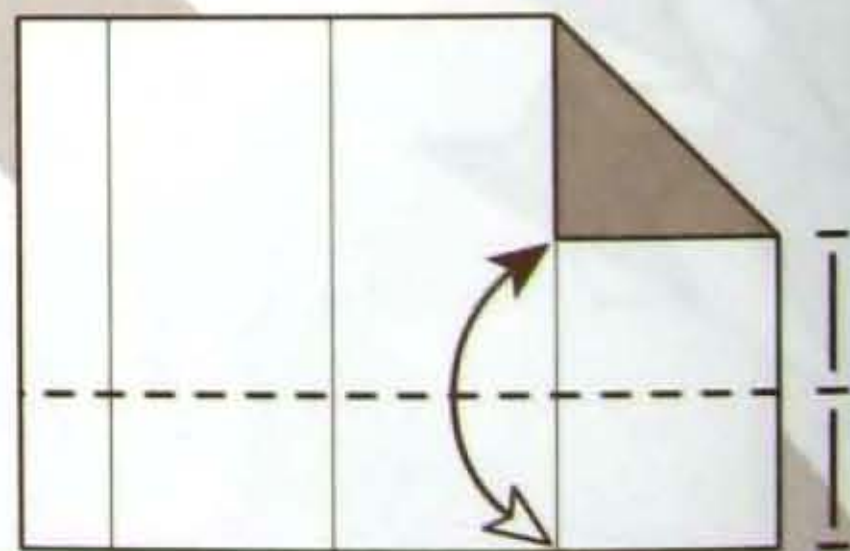

4. 縁を折り筋に合わせて折る

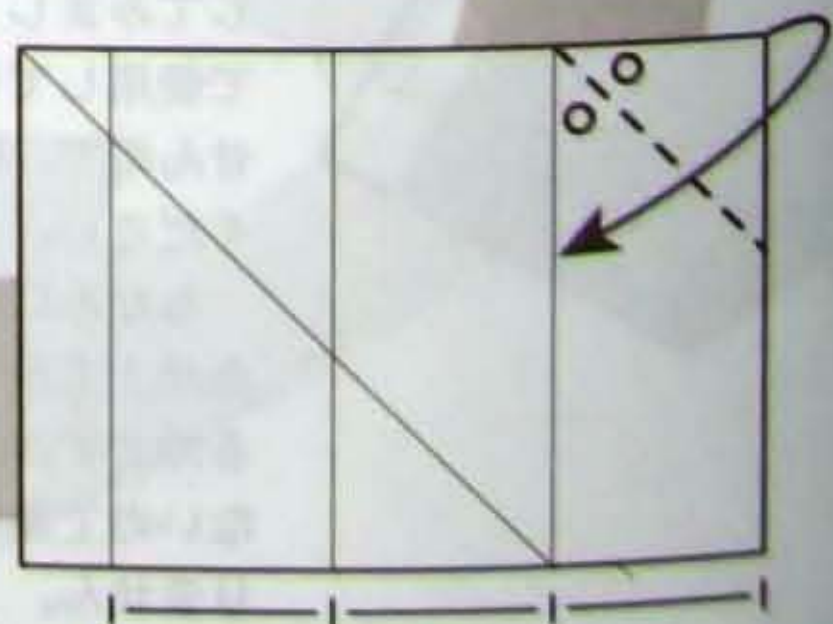

7. ※[A]本体 × 8枚、
[B]ジョイント × 4枚、を用意する

※[B]ジョイントの折り方

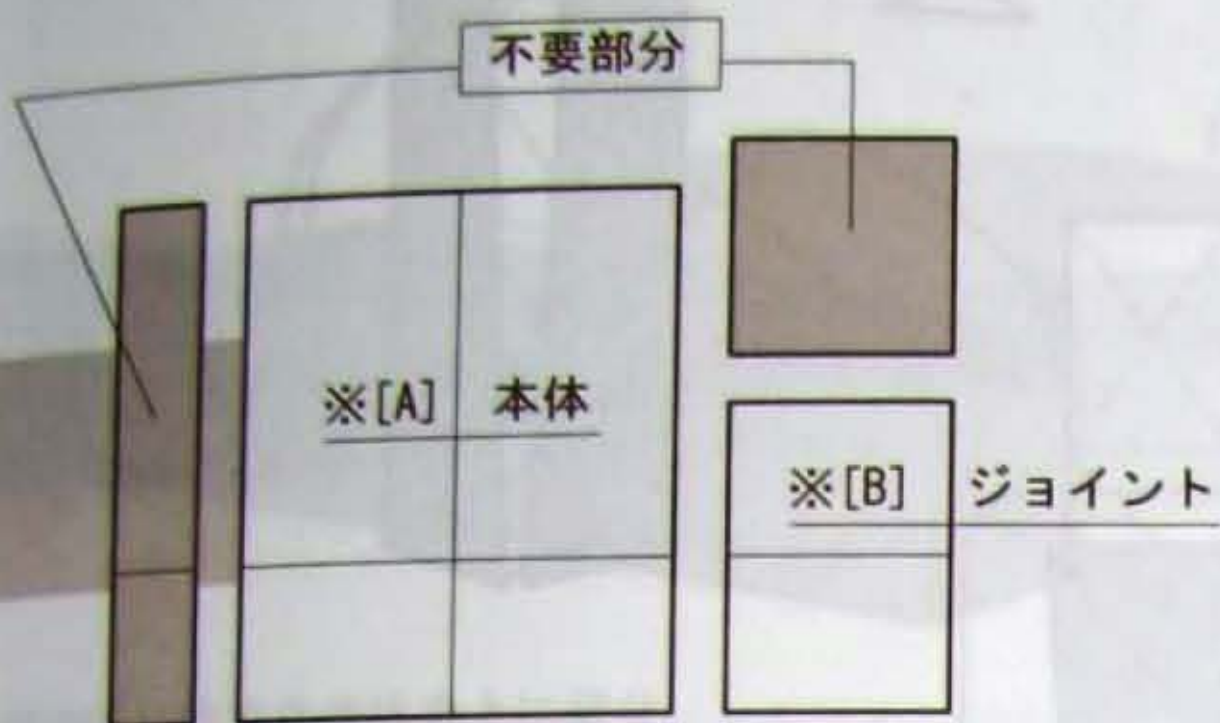

B-1 半分に折る

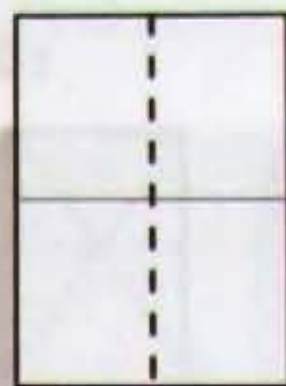

B-3 ジョイントの完成

× 4 個

B-2

後ろに折る



手前に折る

折ったカドを少し戻す

※ [A]本体の折り方

A-1 折り筋を付ける

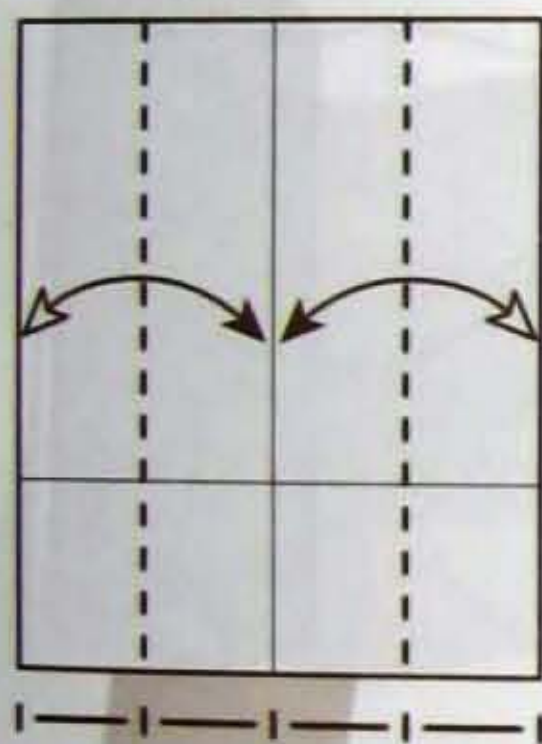

A-5 折り筋を付けたら
全て開く

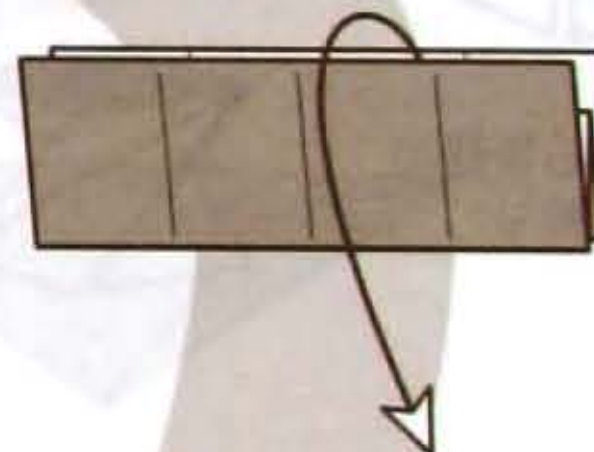

A-4 縁を合わせて折る

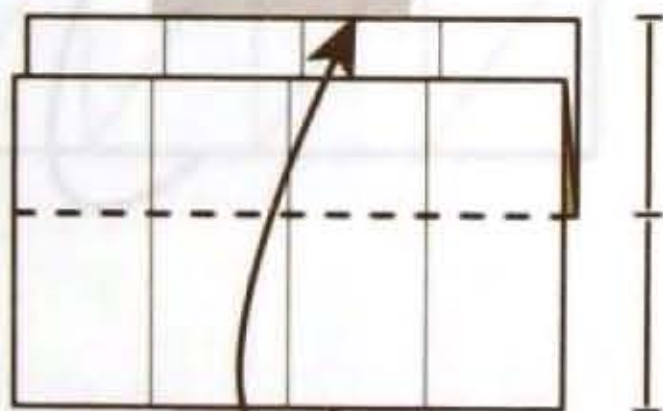

A-6

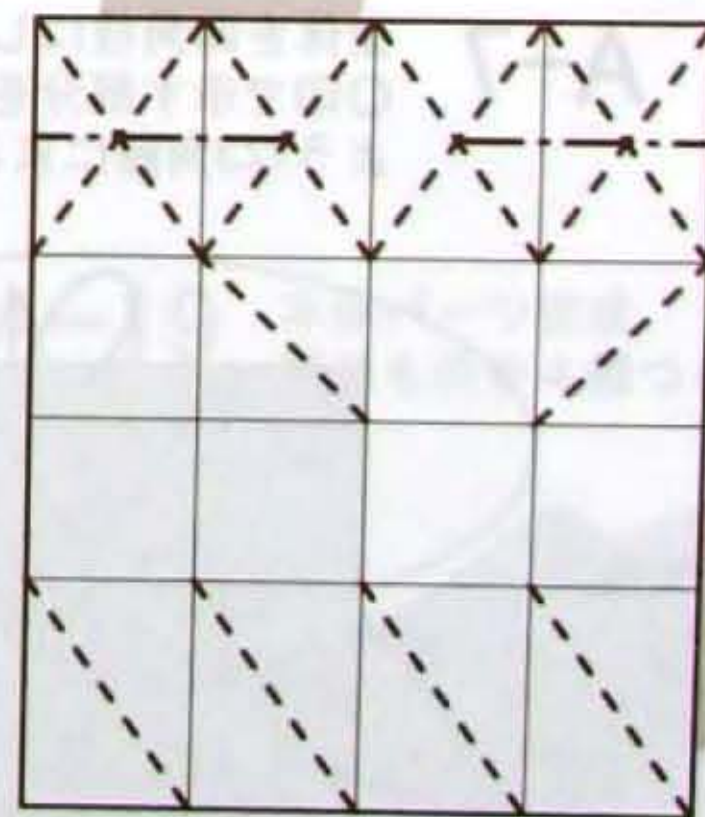

A-2 半分に折る

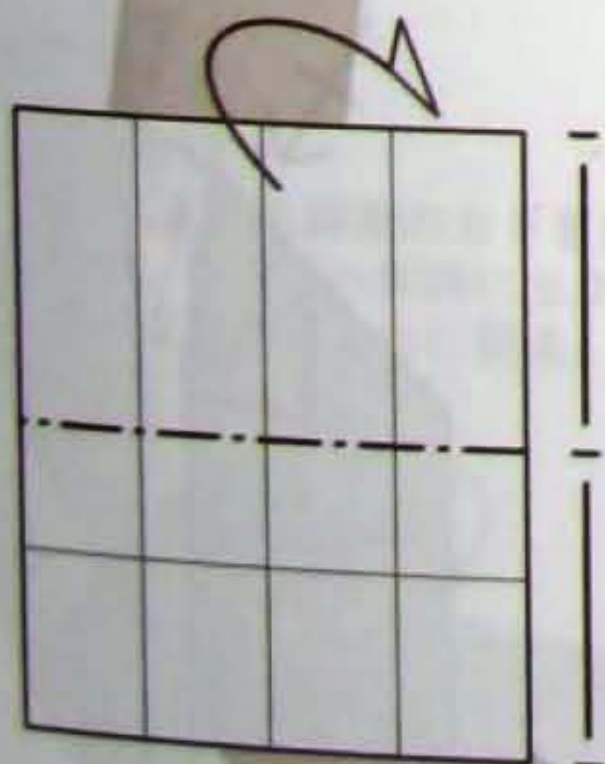

A-3 既にある折り筋で
折る

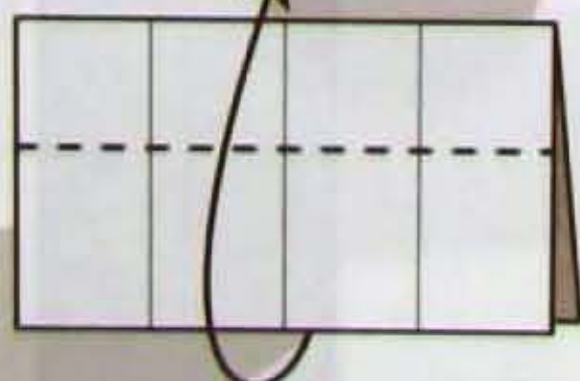

図で示す位置に折り筋を付ける
(他の部分にはなるべく折り筋
を付けないようにすると、後で
まとめ易い。)

A-13 向きを変えて横から見る

C-1

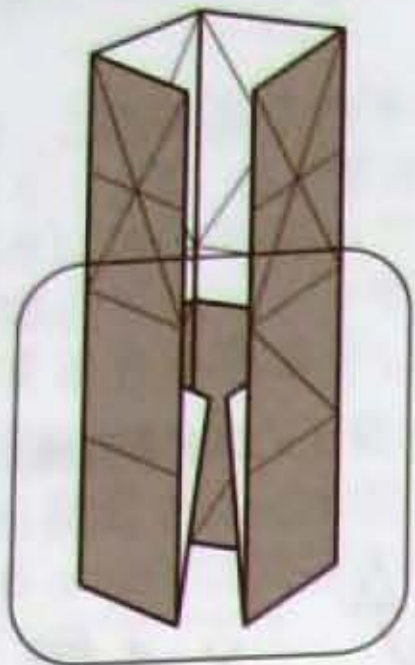

内側の紙は、[C-2~3]のように折る

(↑説明のため、外側の紙を省略し内側の紙だけを表示)

A-12 既にある折筋で立体化する

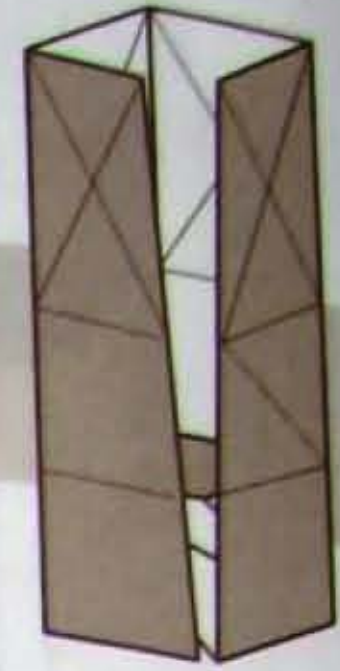
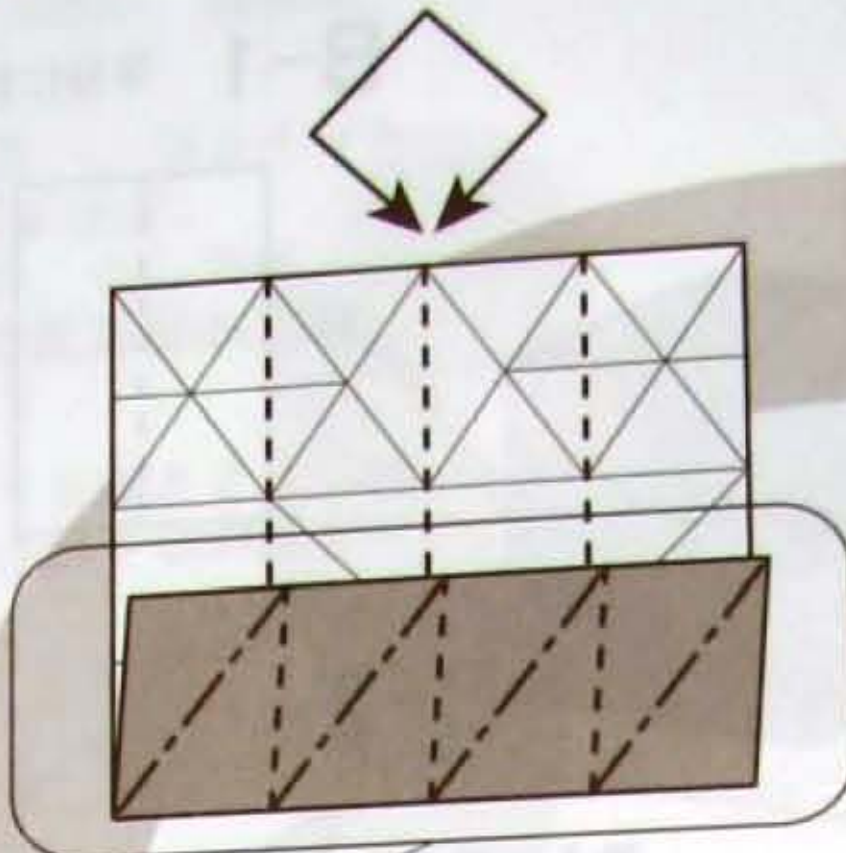

C-2

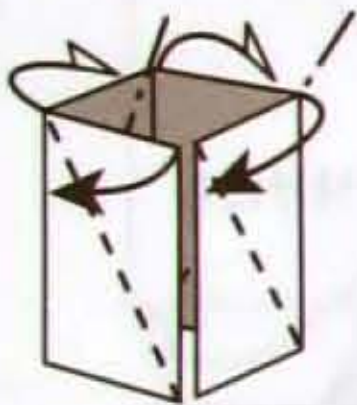

既にある折筋でねじり折り

C-3

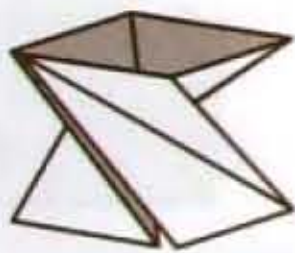

A-11 既にある折筋で折る

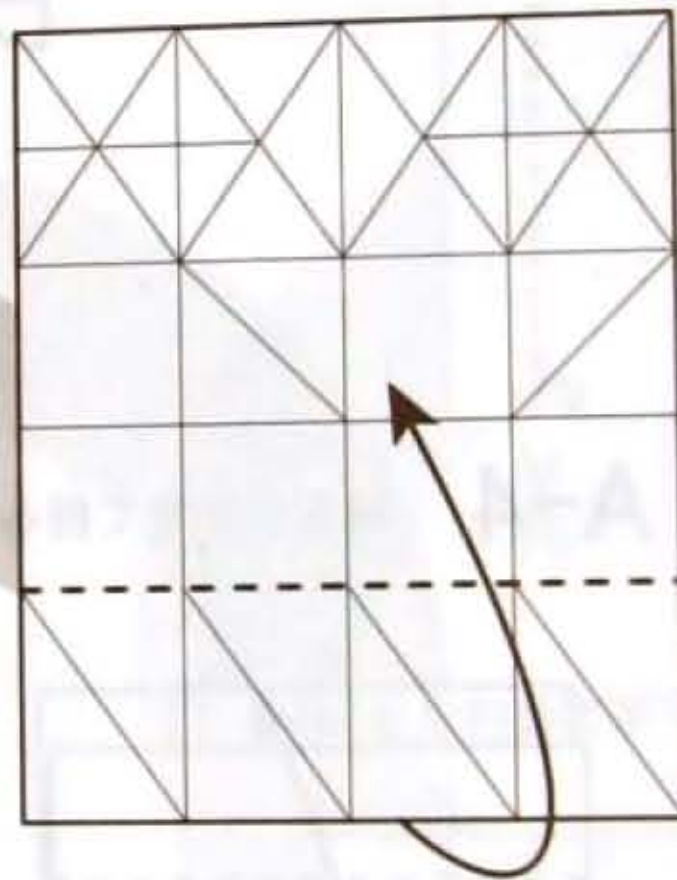

A-10 折り筋を付けたら全て開く

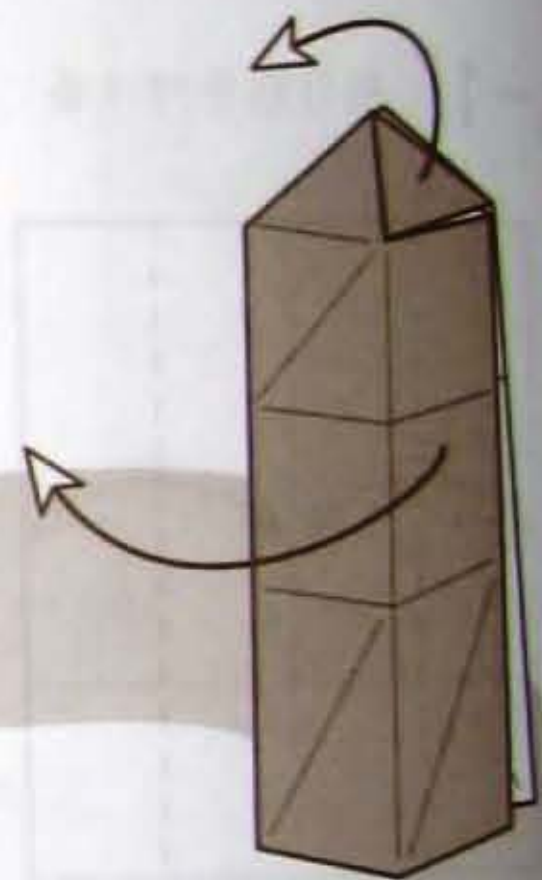

A-7 全体を四角柱にしなごら、○印で示す部分を次の図のような三角錐にまとめる

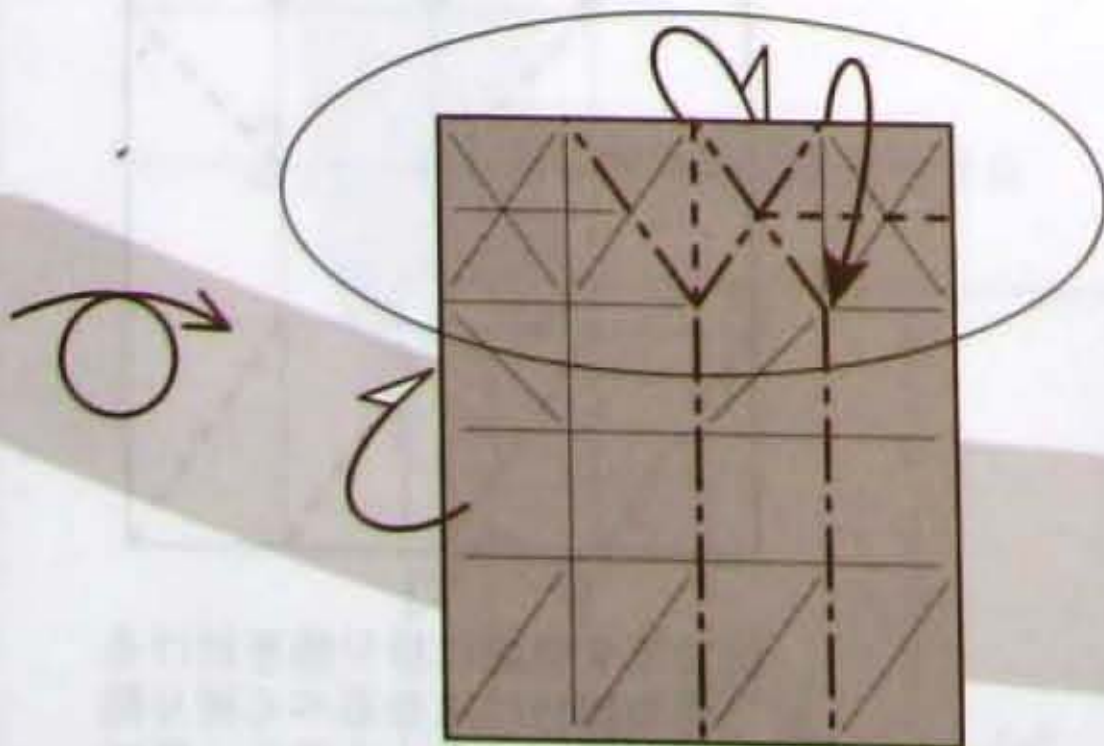

A-8 [a]のカドを[b]の三角錐のポケットに差し込む

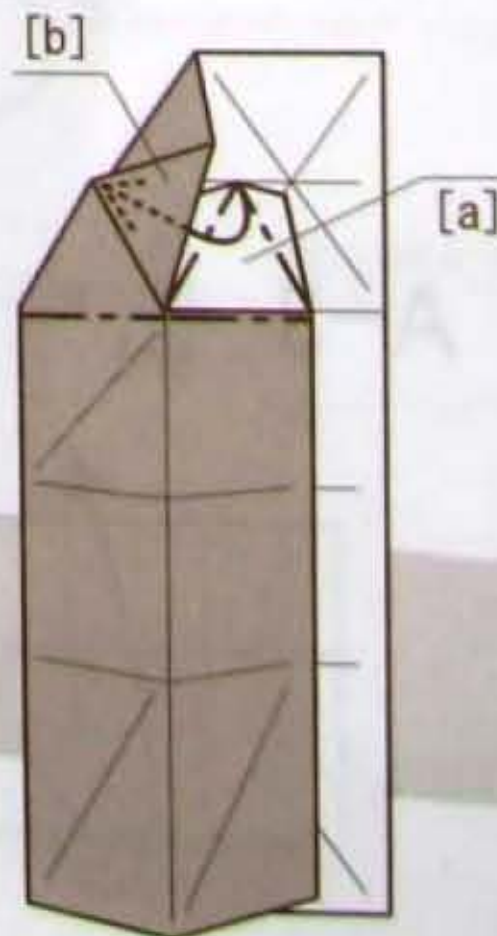

A-9 反対側も[A-7~8]と同様に折る



A-14

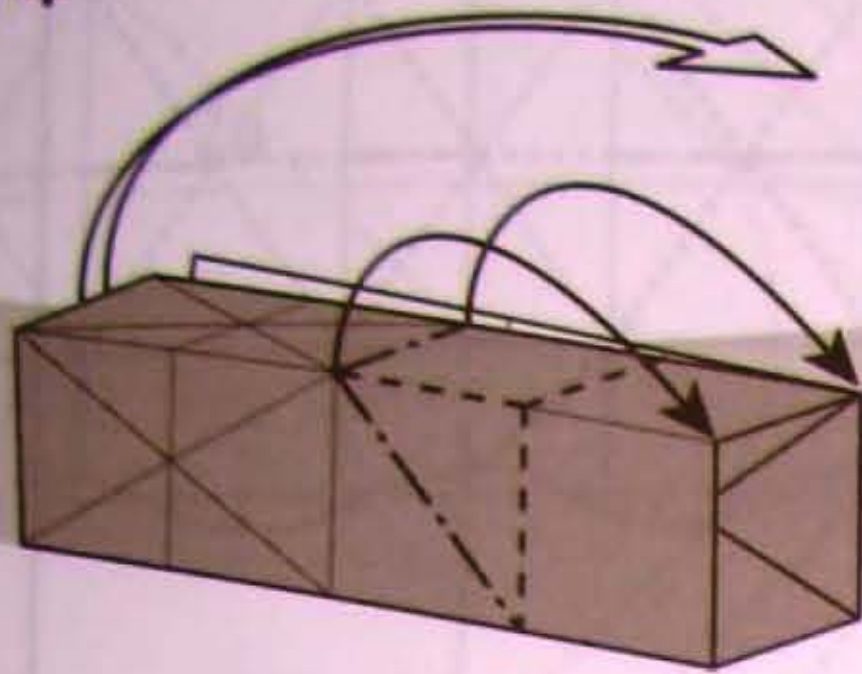

A-14'

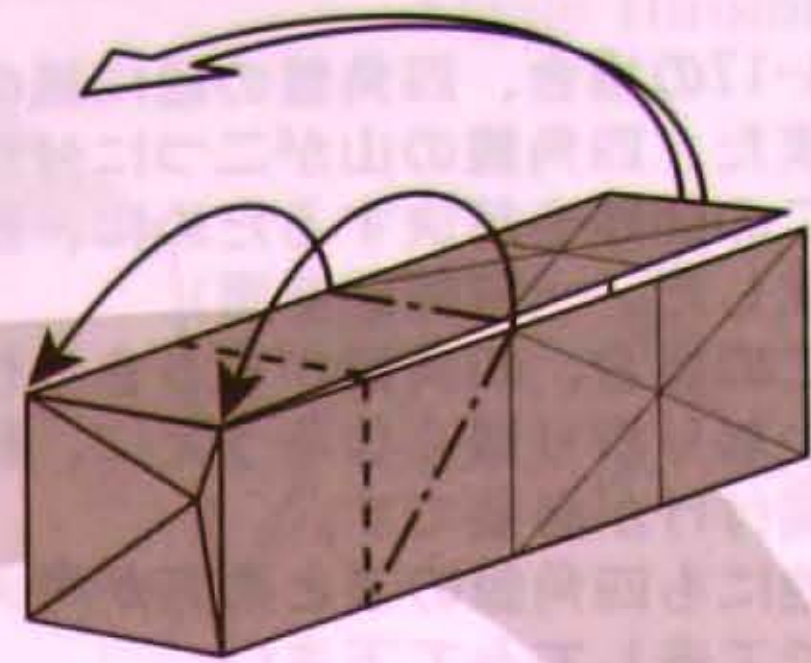

「反対側から見る」



図の折り筋で立方体の上に被せるようにしてカドを立てる

Japão Burajirujin
www.japaoburajirujin.blogspot.com

A-15

A-15'

A-16

○印で示す部分を[A-10]の形にまとめる

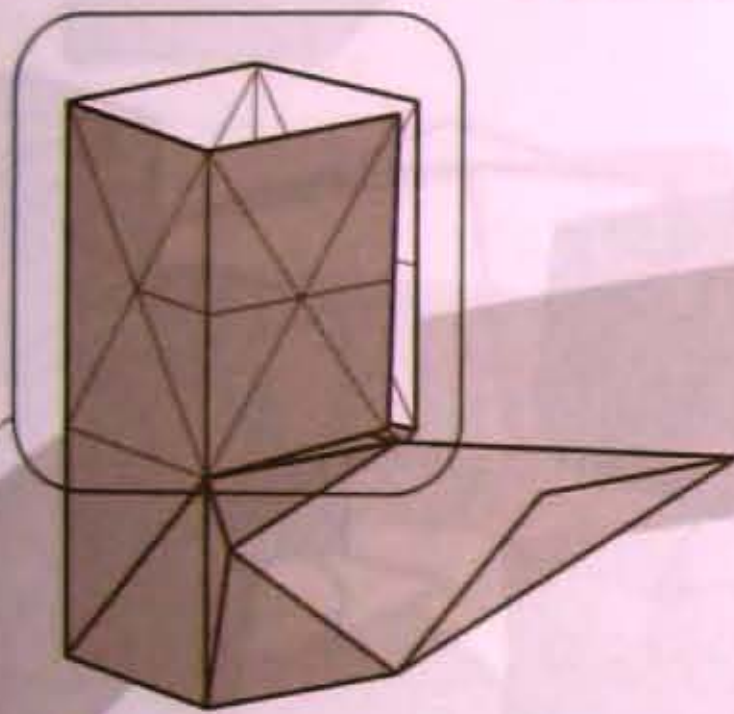

[A7~10]と同様に折る

「反対側から見る」

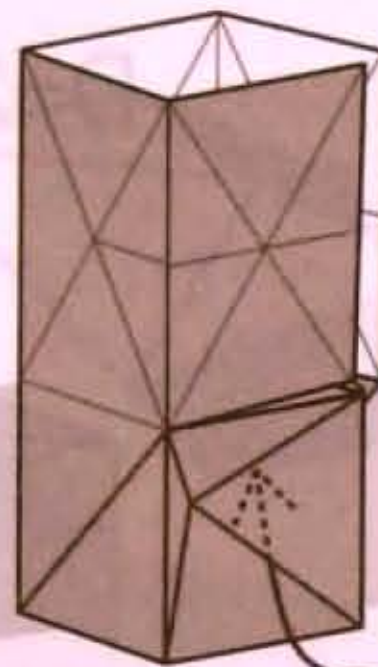

ジョイントを本体に
(しっかり奥まで)
差し込む

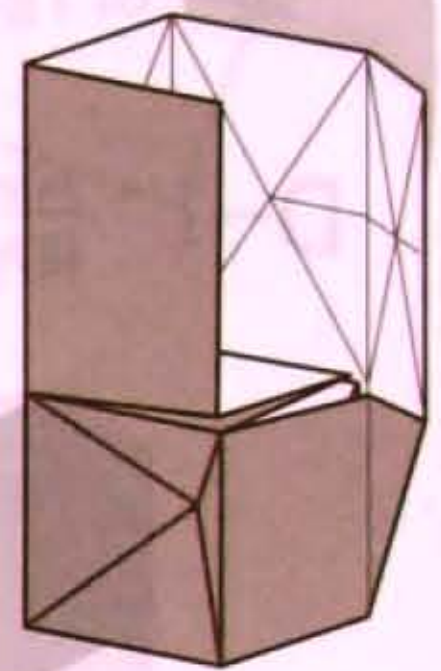

A-18

○印の部分に[A-15~17]と同様にして本体を取り付ける

A-17

<途中図>
(中に入れる両側のカドを先に折り、両カドへ同時に上から屋根を被せるように折る)

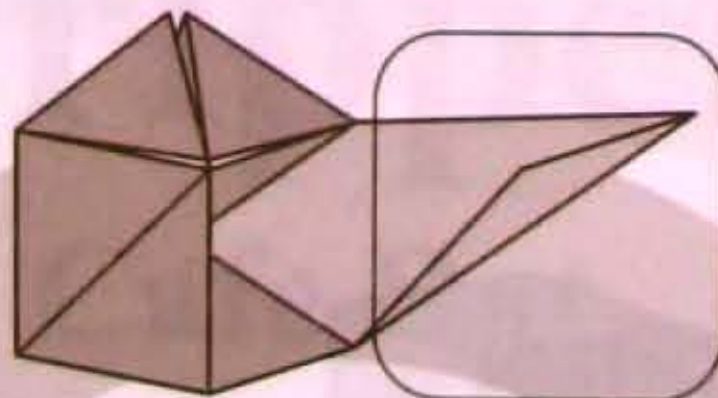

A-19

本体パーツ完成
同じものを4個つくる

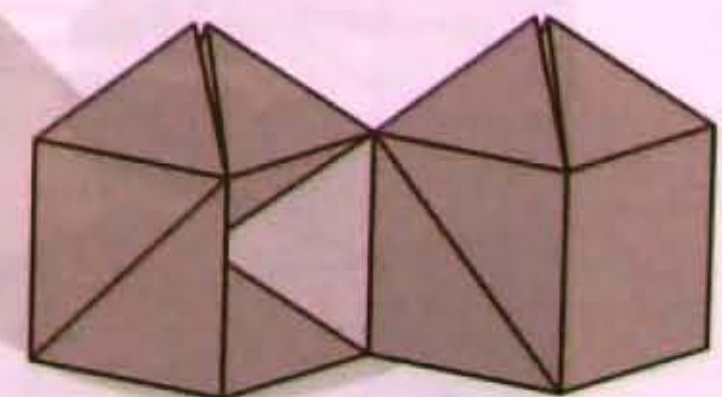
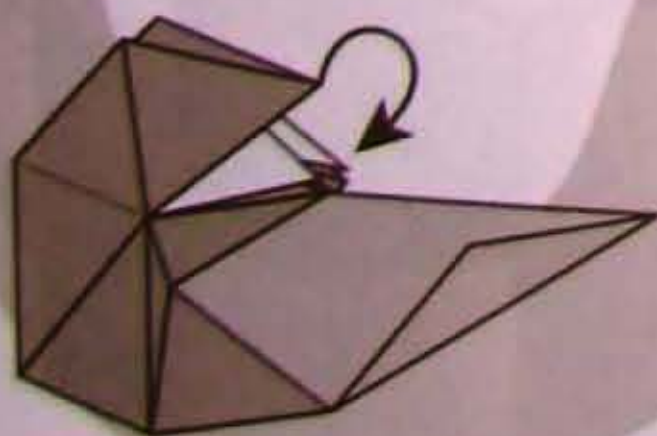

× 4 個

...『A-17』の別なまとめ方を紹介します...

A-17の場合、四角錐の縁に紙の裏が出ます。
 また、四角錐の山が二つに分かれてしまいます。
 この問題を解決するために、別の折り方を考えてみました。(展開図参照)
 この場合、四角錐がすっきり仕上がります。ただ、かなり折り難くなるうえに、紙質によっては最後に糊付けが必要です。
 他にも四角錐のまとめ方が考えら得ると思いますので工夫してみてください。

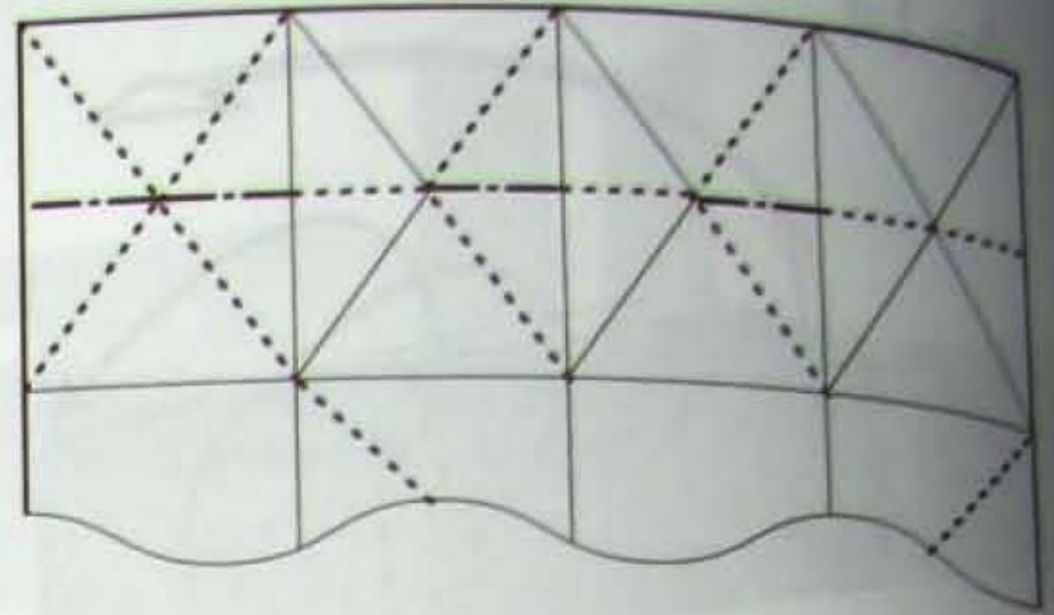

※ Origami Cube Puzzle の組み方

D-1 凸凹を合わせて二つのパーツを組み合わせる

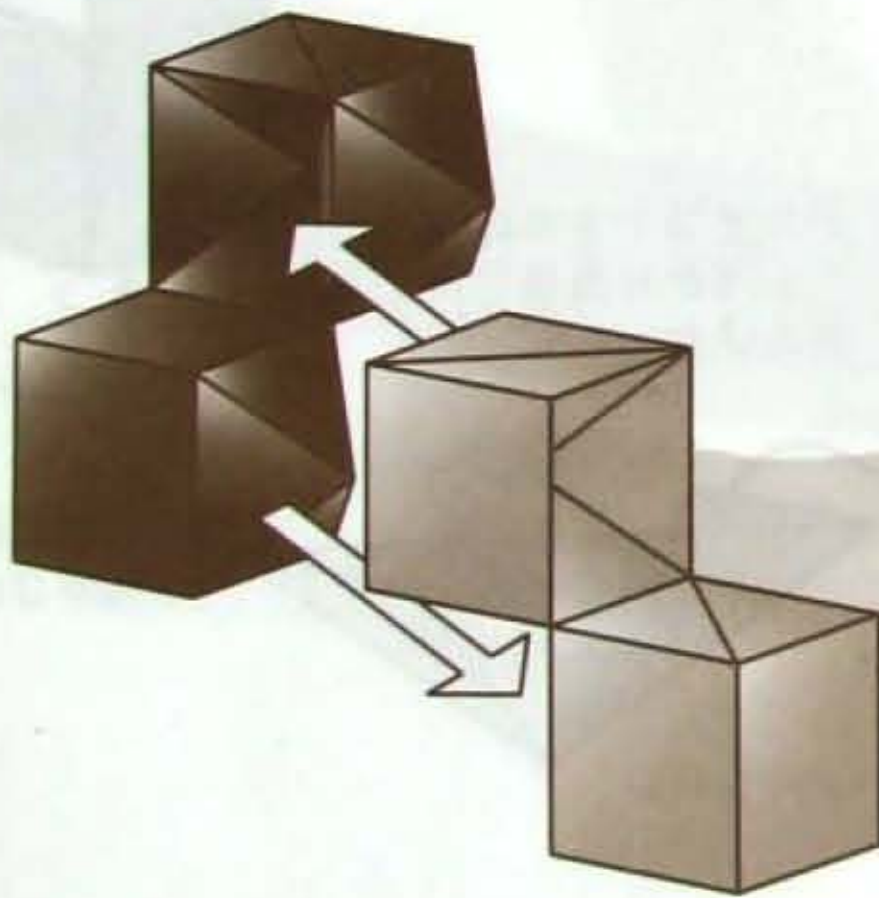

D-2 もう一組のパーツも同様に組み合わせる

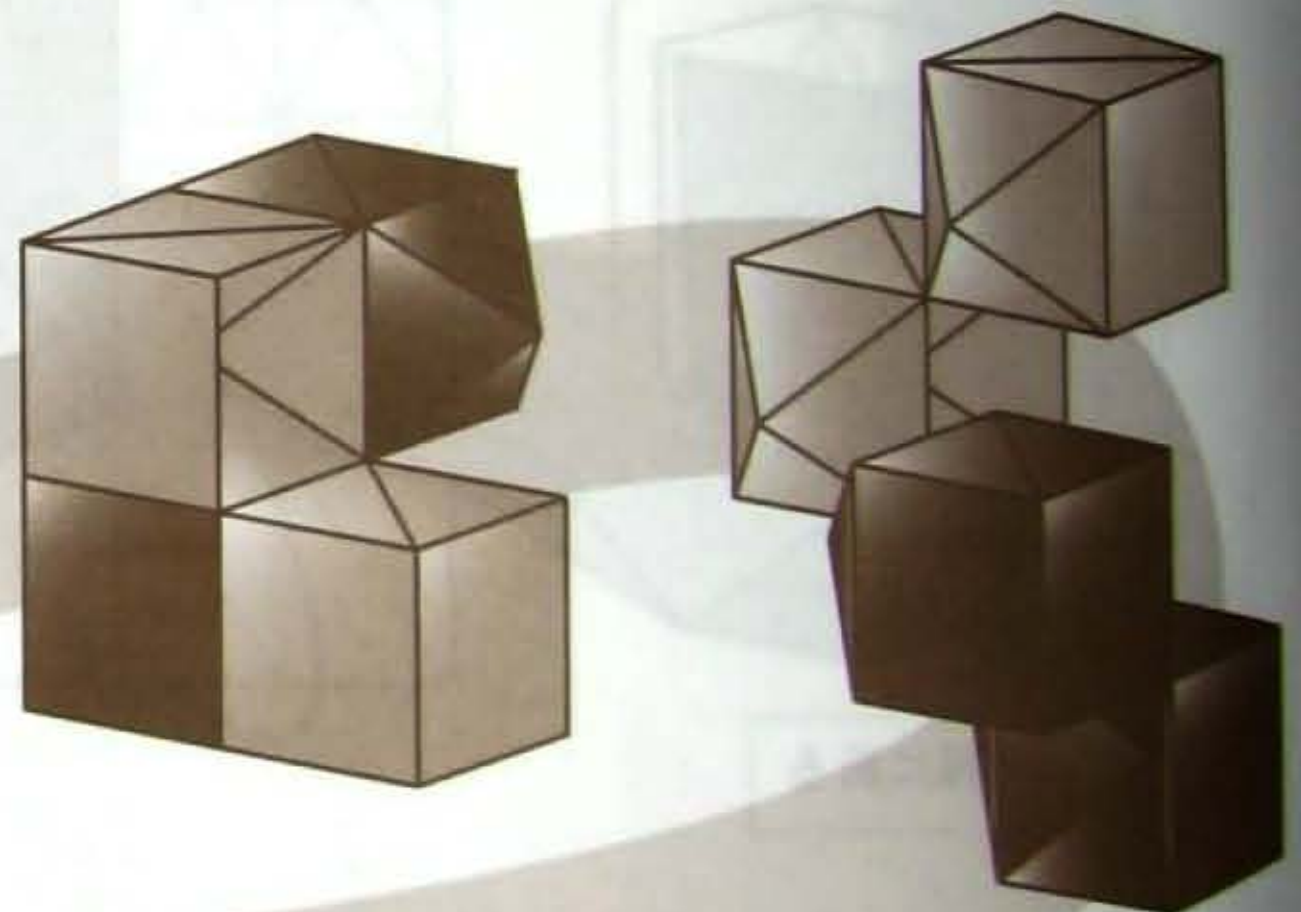

D-3 二組を斜めにスライドさせるようにして組み合わせる

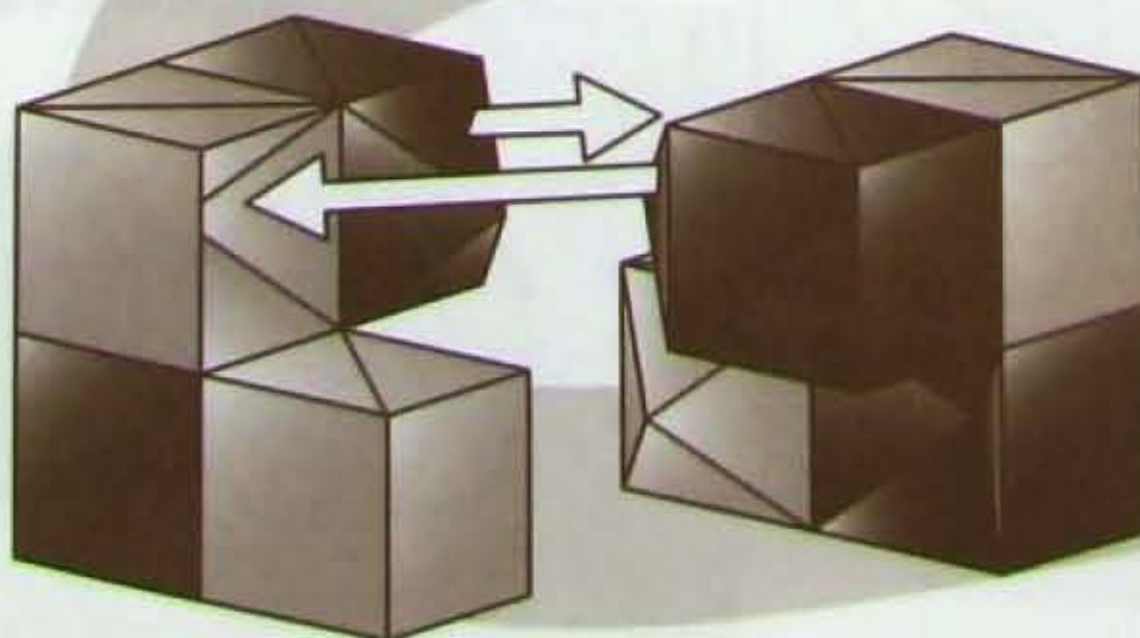

D-4 完成

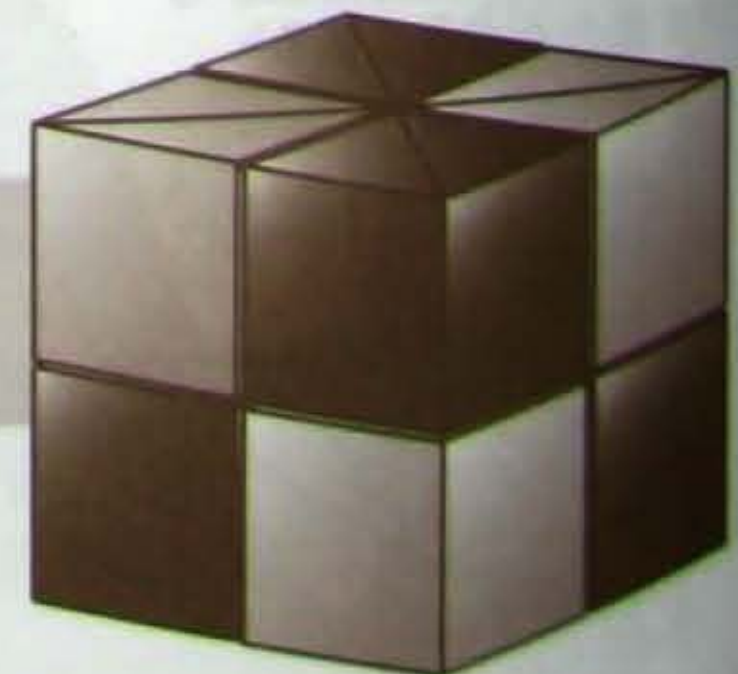



作/図 小方 弘巳
Ogata Hiromi

Coffee Dripper

Cafe Rat

防水紙の入手は高価かつ困難なので牛乳パックを利用。
19cm × 19cm位で ストッパーは3cm × 12cm位に
濾紙はクッキングペーパー(ペーパータオル)を
下の図の様に折って使う。

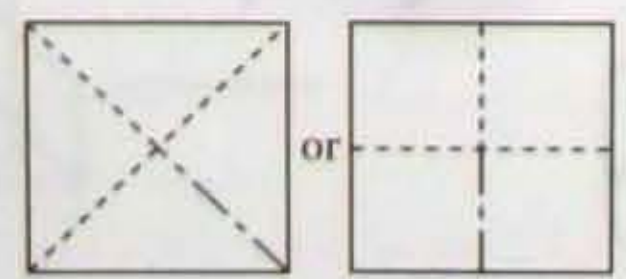

2010.08.07 創作 Designed 2011.06.05 作図 Diagrammed

ジャコランタン Jack-o'-Lantern

前川淳
MAEKAWA Jun

宮本宙也さんの
作品にヒントを
うけた造形です。

Japão Burajirujin

www.japaoburajirujin.blogspot.com

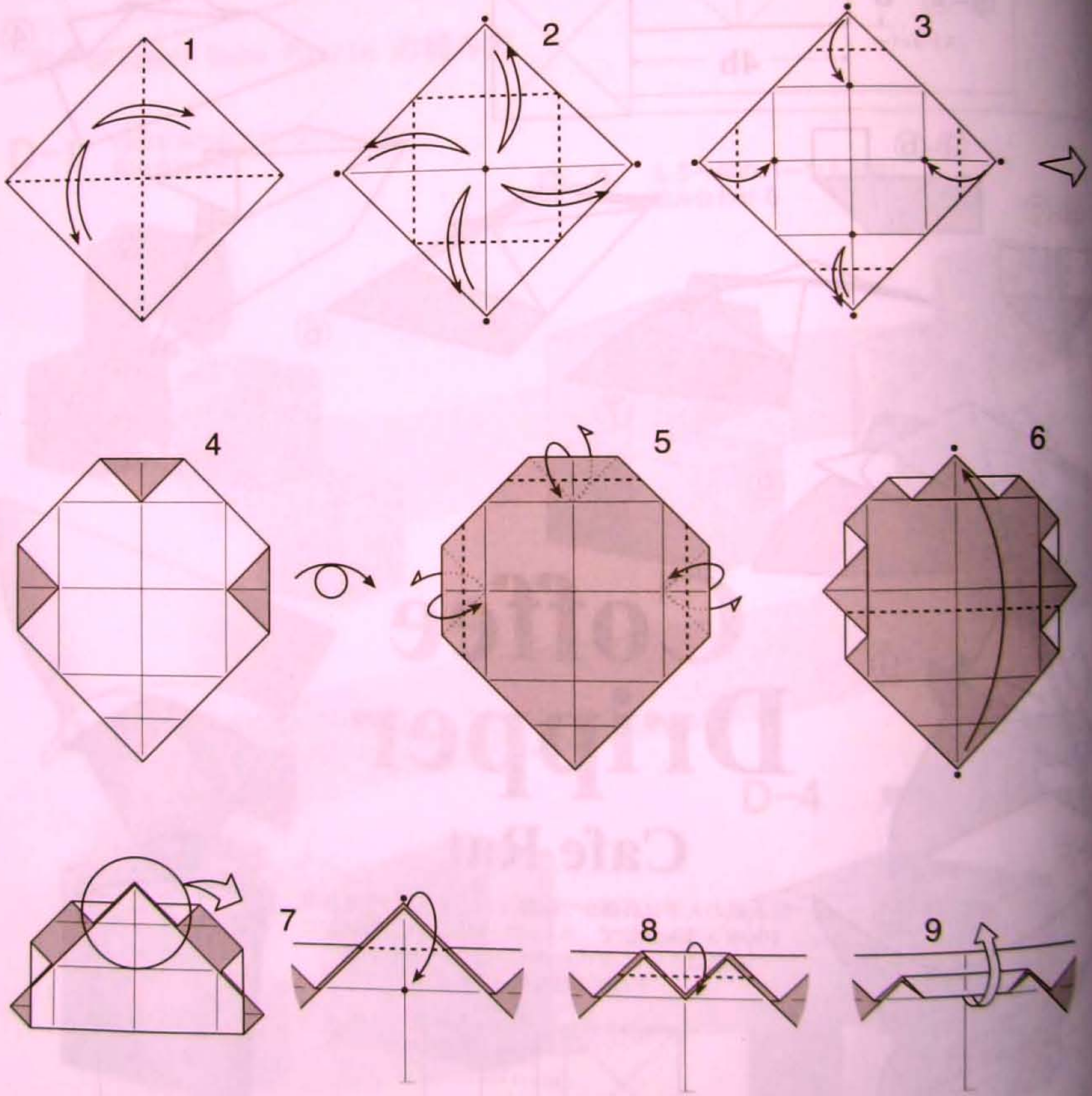

7までもどします。

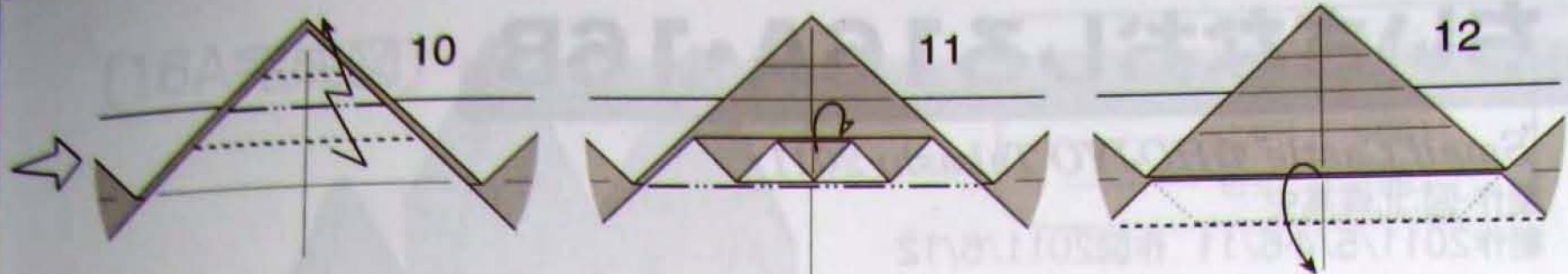

同じ幅で折り返します。

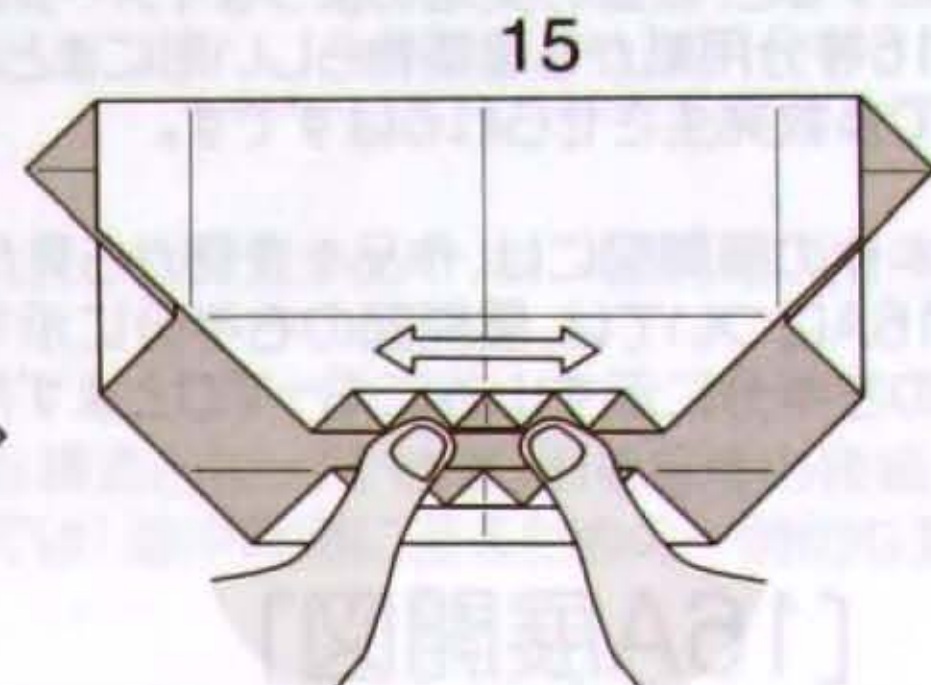
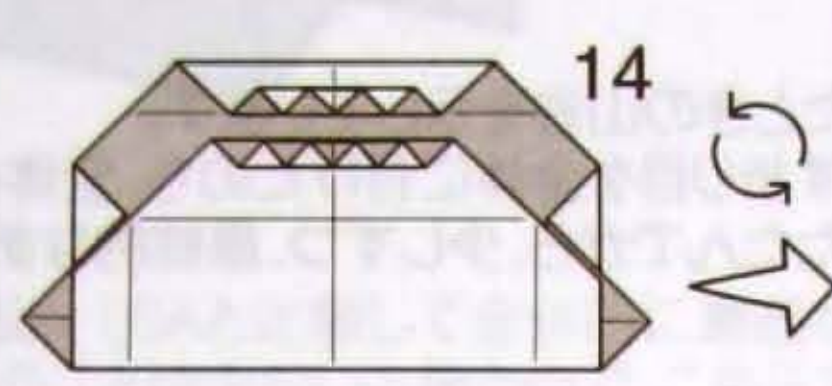
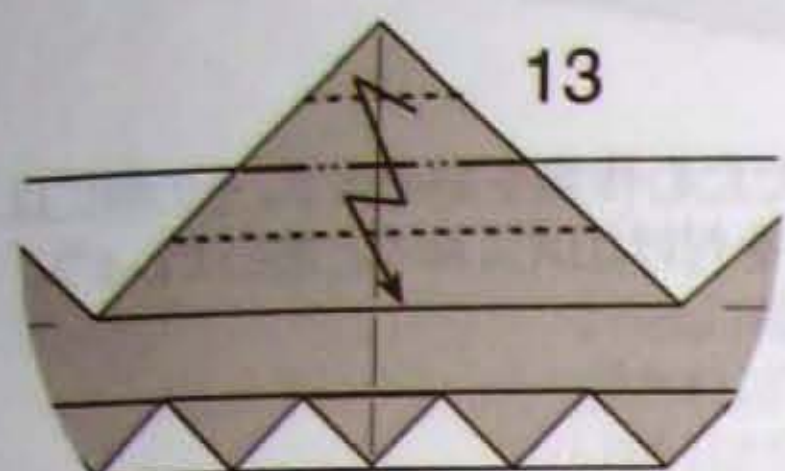

折り目がひらかないように、
しっかり「しごき」ます。

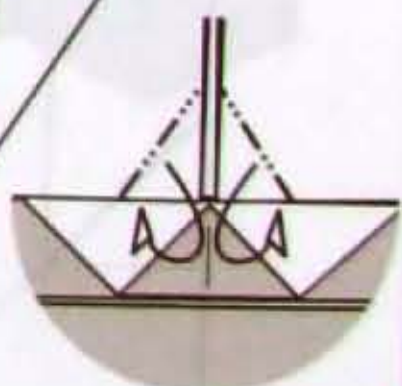
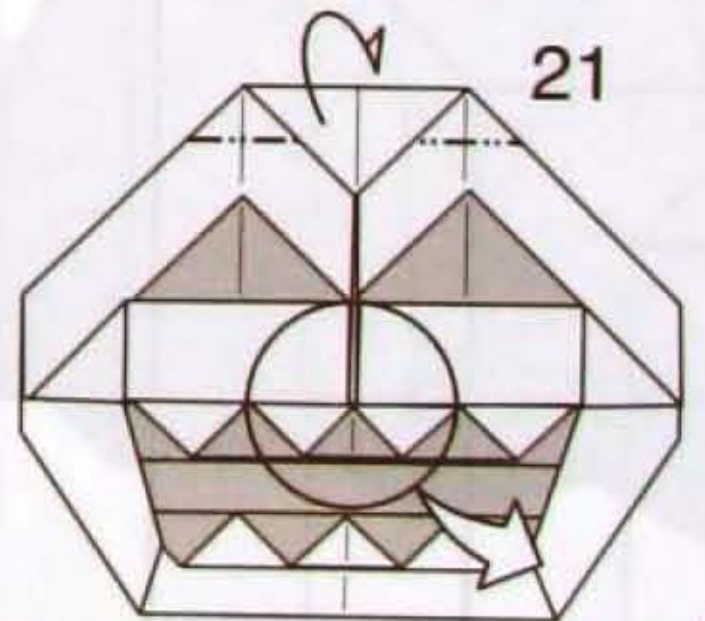
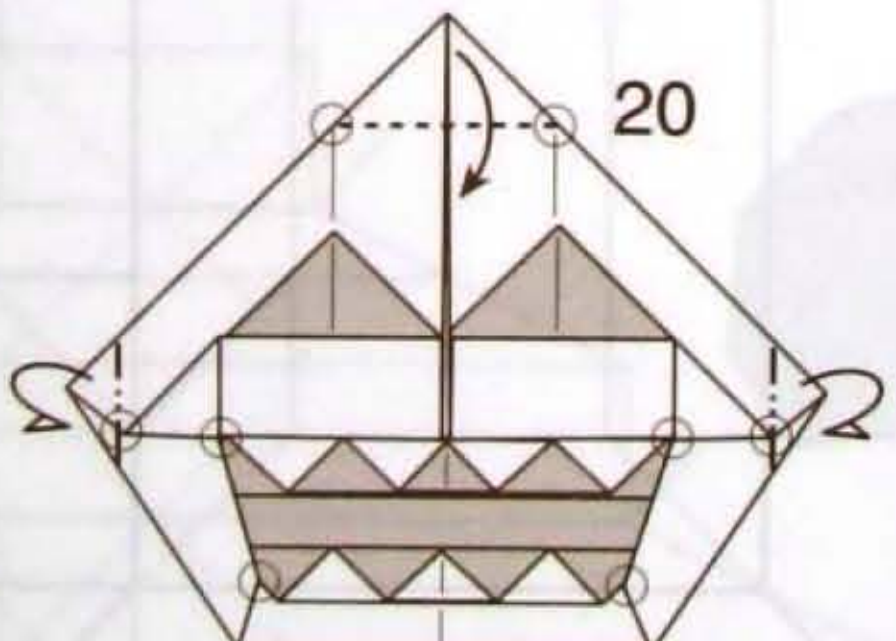
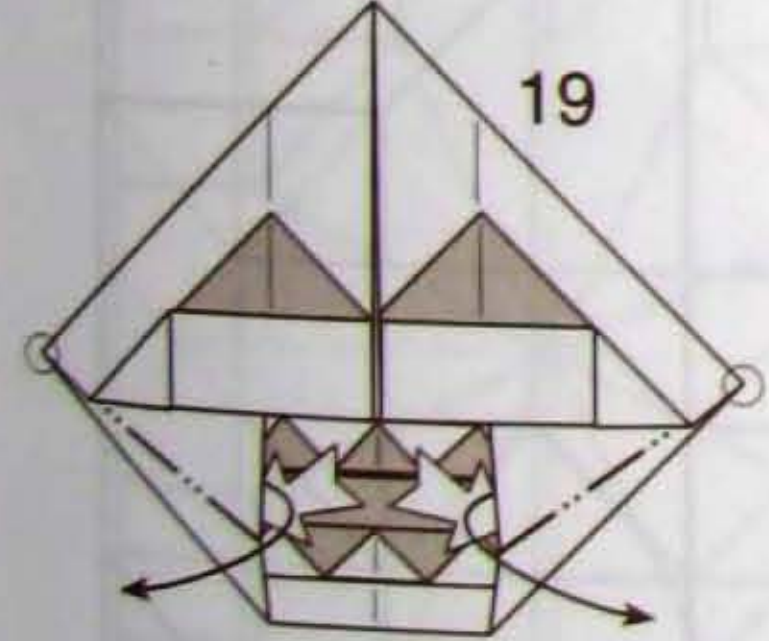
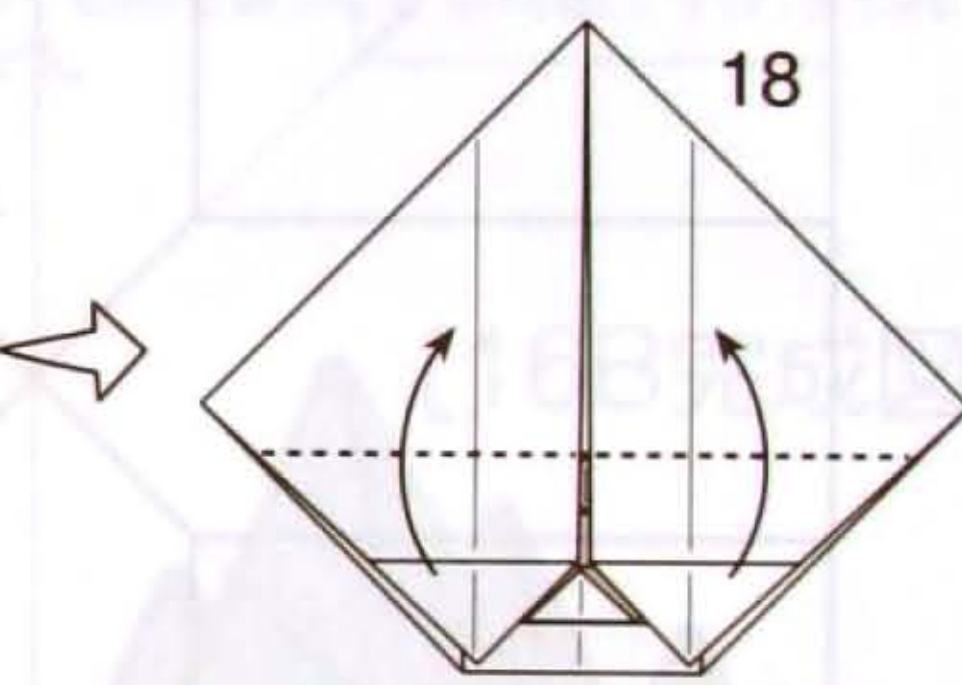
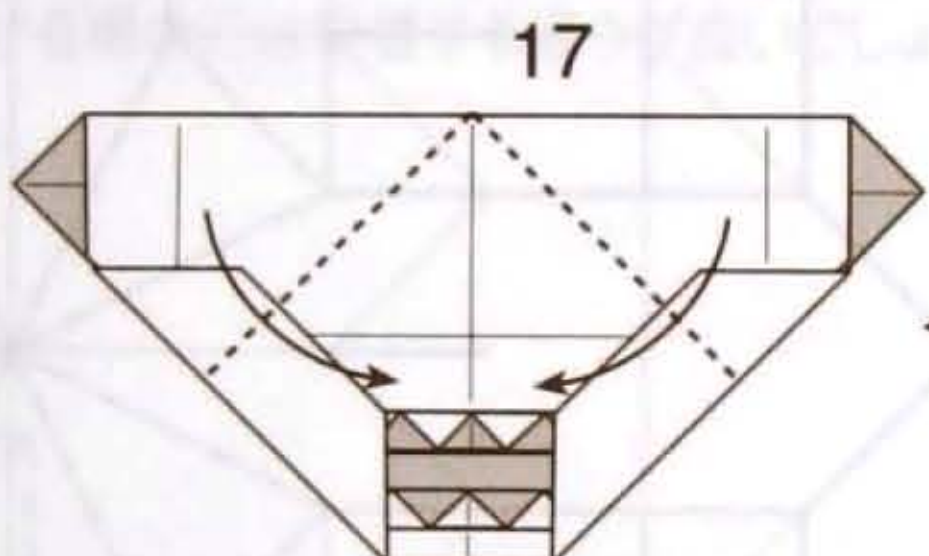
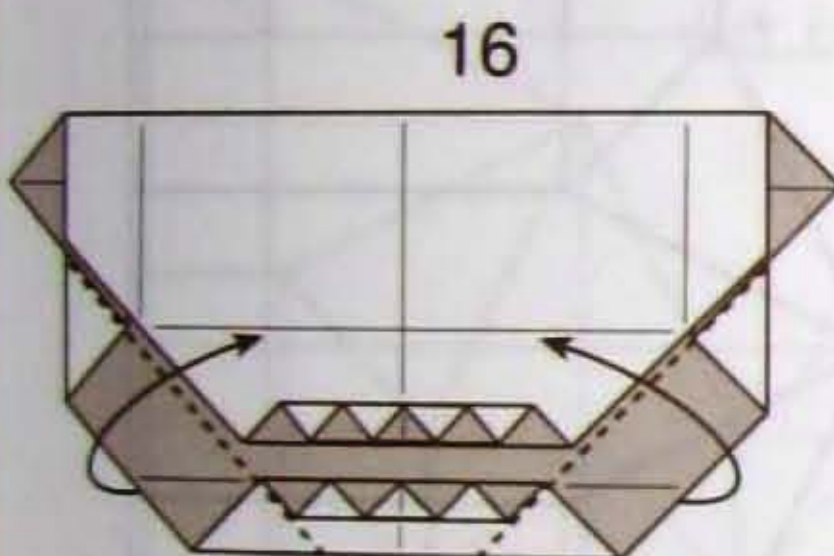

ひらく角度は次の図を
見てください。

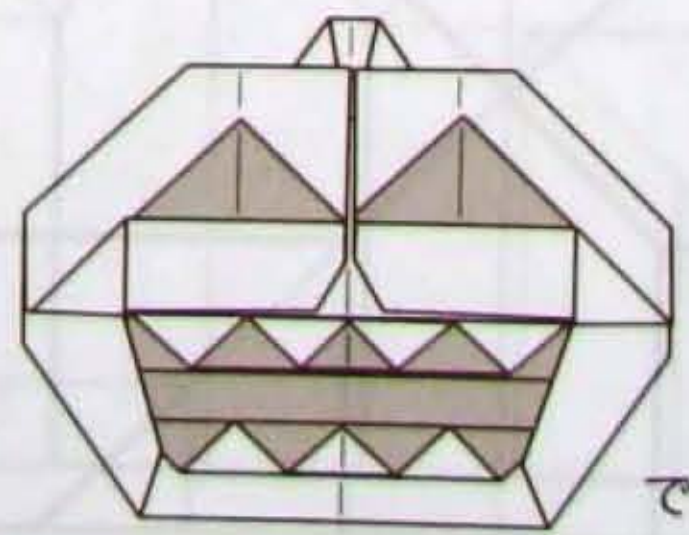
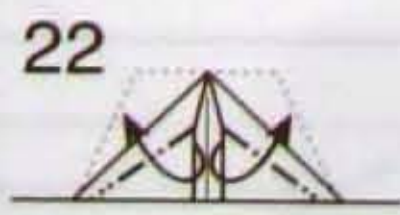
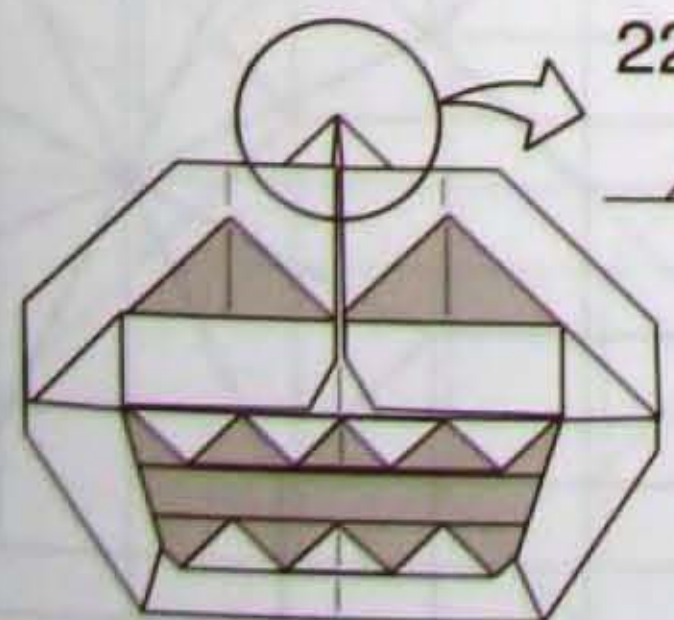

できあがり。

ちいさなおしろ 16A・16B

"Small Castle" ©HOJYO Takashi 2011

創作・図: 北條高史

創作 2011/5/4・6/11 作図 2011/6/12

基本骨子は、川崎敏和氏のユニット「水晶」を1枚の正方形に複数詰め込んだ構造。そこから突起の先端を半開状態にすると、教会の尖塔のようなイメージになります。
16等分用紙から建築物らしい形にまとめた例を示しますが、蛇腹の分割を細かくすれば、塔をいろいろな長さ・場所
で多数発生させられるはずです。

本作の展開図には、作品を表側から見たときの山谷を示しています。
16Aについては、展開図の右半分を示す折り目を全体に付けたのち、全体をたたむ作業を始めます。その際には、図
の左半分を示す山谷に沿ってひとまずたたんでから、少しずつ、最終的な折りを付け加えてゆくと良いでしょう。

[16A展開図]

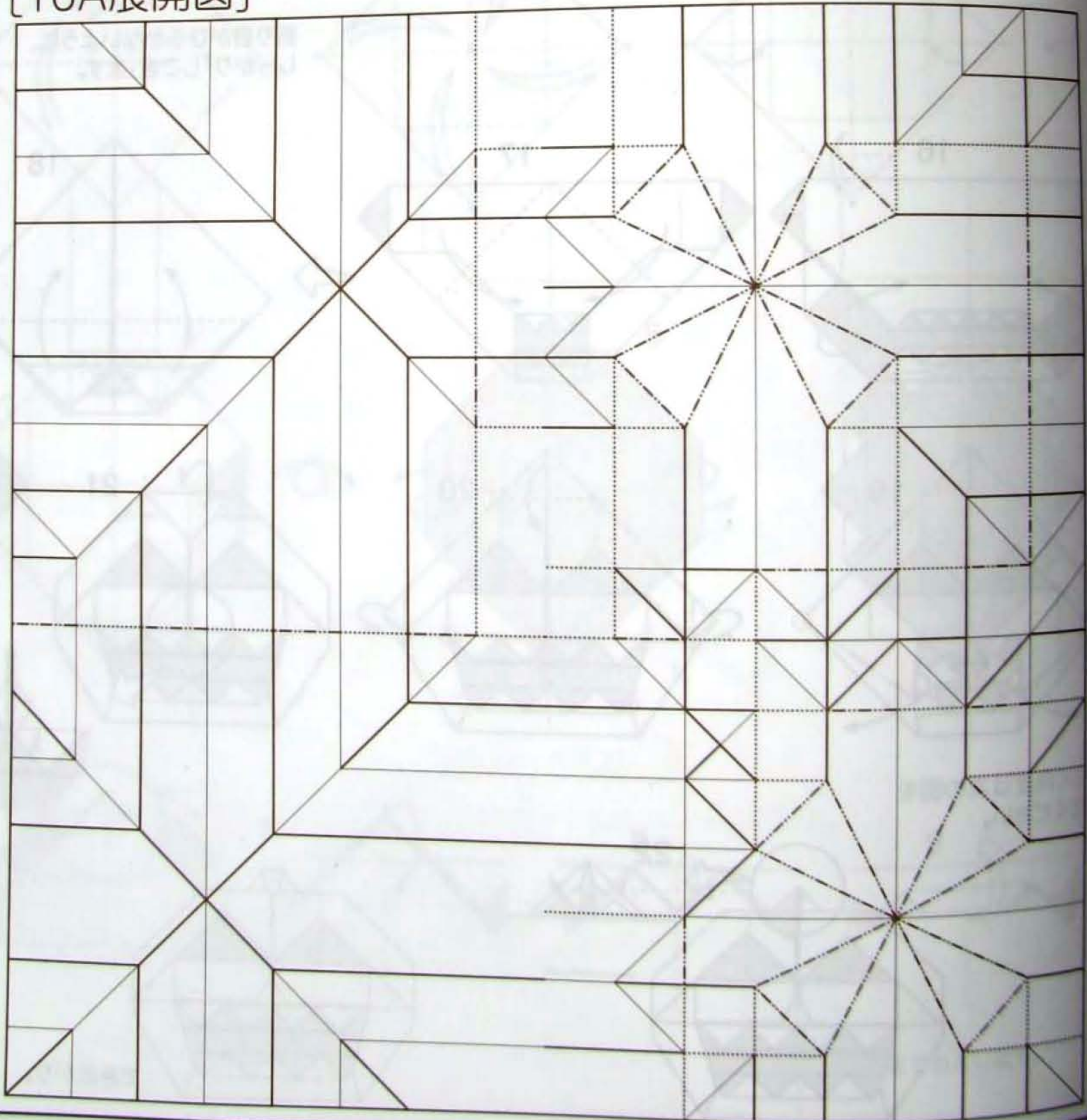

[16A完成図]

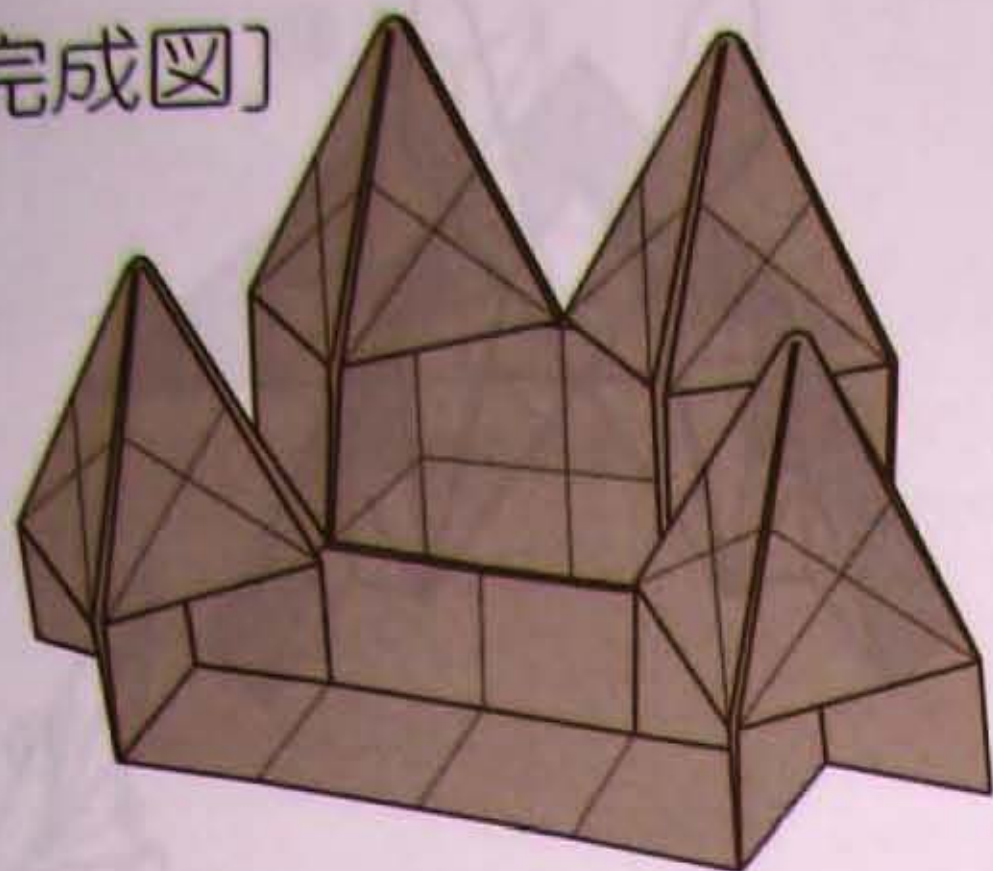

- 山折り(平面)
- 谷折り(平面)
- 山折り(半開)
- 谷折り(半開)

Japão Burajirujin

www.japaoburajirujin.blogspot.com

16Bの構造は、16Aと比較して全体的に素直な構造となっています。ある程度の技術があれば迷うことは少ないと思うので、こちらでは「途中段階に至るための一時的な折り線」は示していません。

一部、左右非対称な加工となるところについては展開図の左上端と右下端に示していますが、ほかの部分は対称です。

双方の作品とも、留め折りを多数施せば糊なしでも形を保つことは可能ですが、きちんと仕上げる場合には接着するほうが良いでしょう。

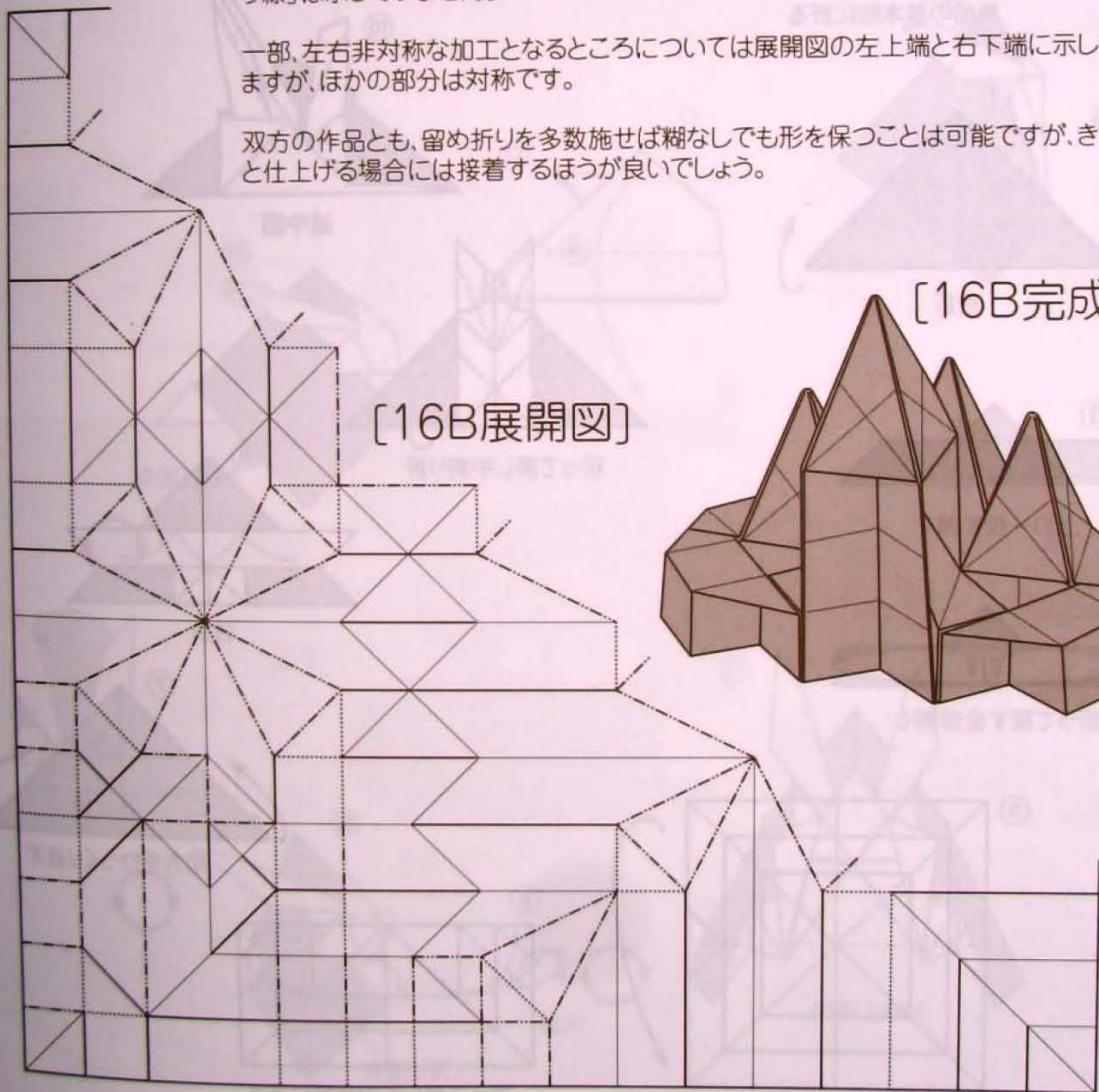

[16B展開図]

[16B完成図]



祝かぶと

浜田勇

創作H20年01月25日 作図H22年05月15日

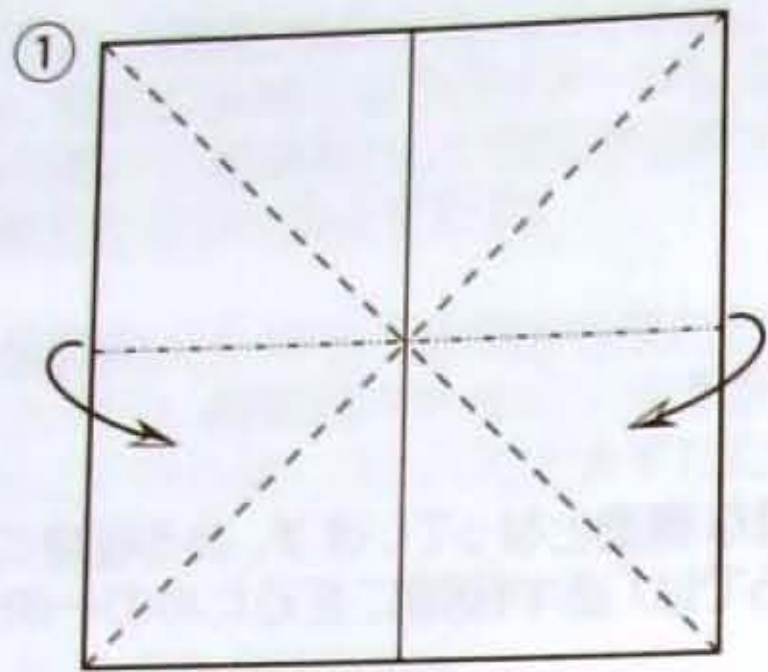
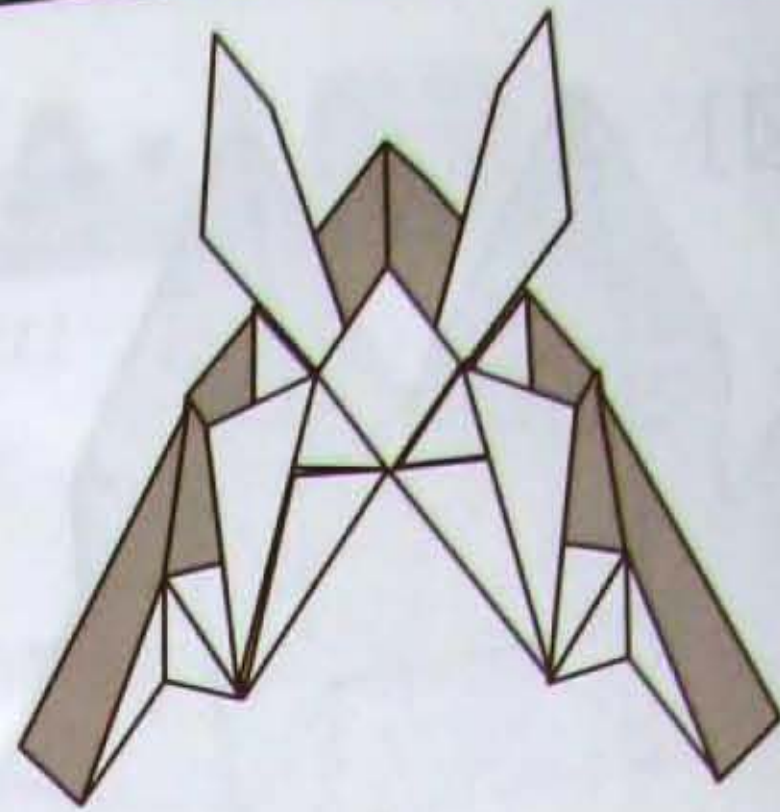

① 風船の基本形に折る

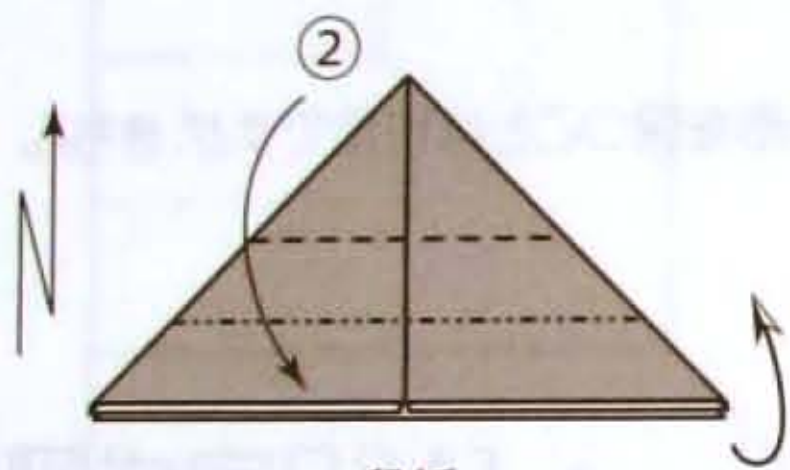

② 段折



③ 上の一枚を開く



④ 折って戻す全部開く

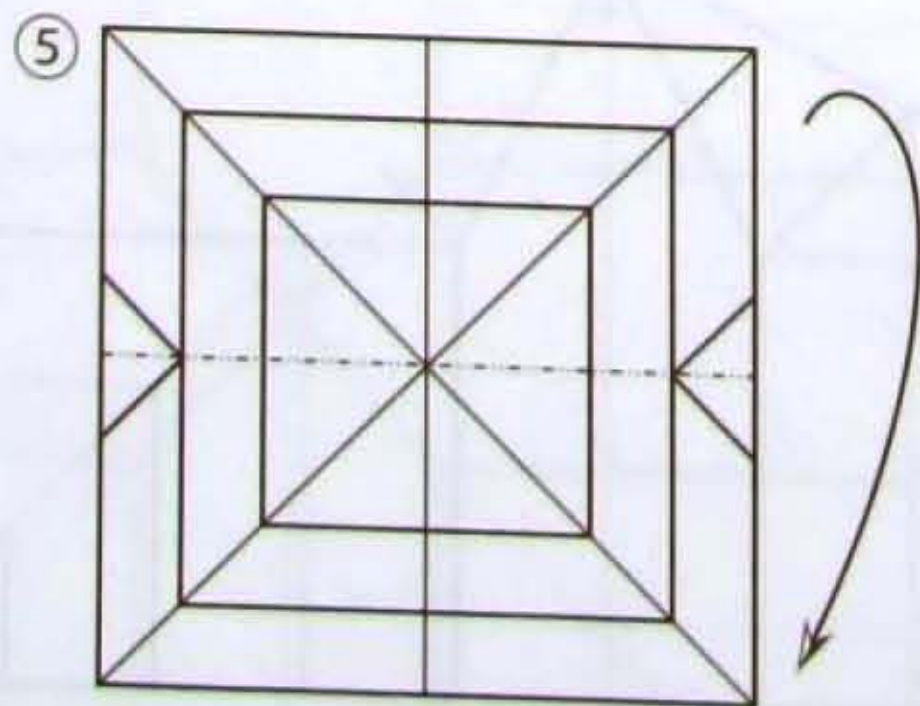

⑤ 山折

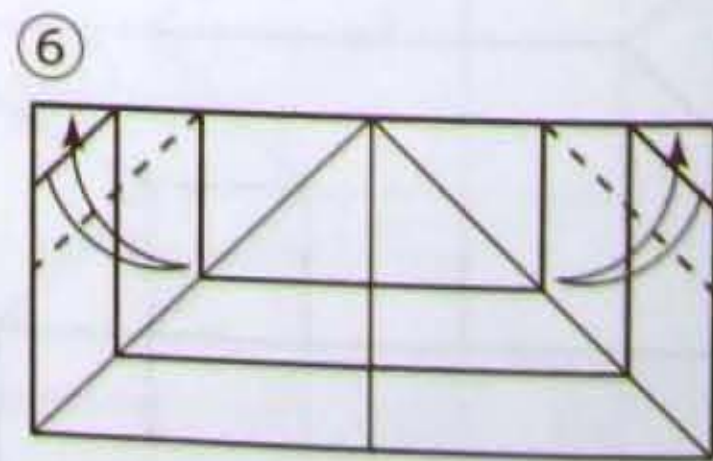

⑥ 折って戻し②の状態にする

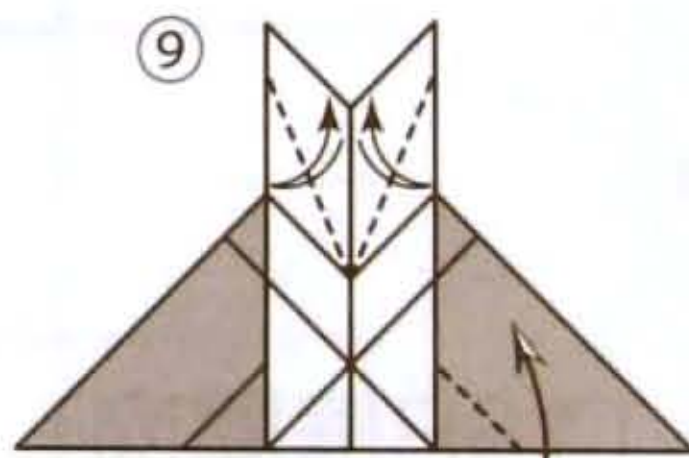

⑨ 折って戻し中割り折

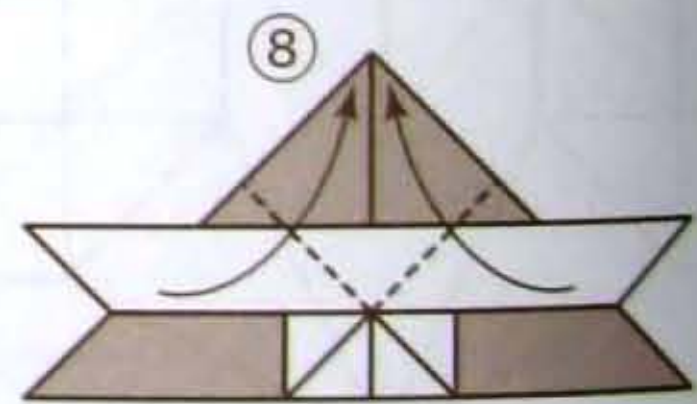

⑧ 谷折

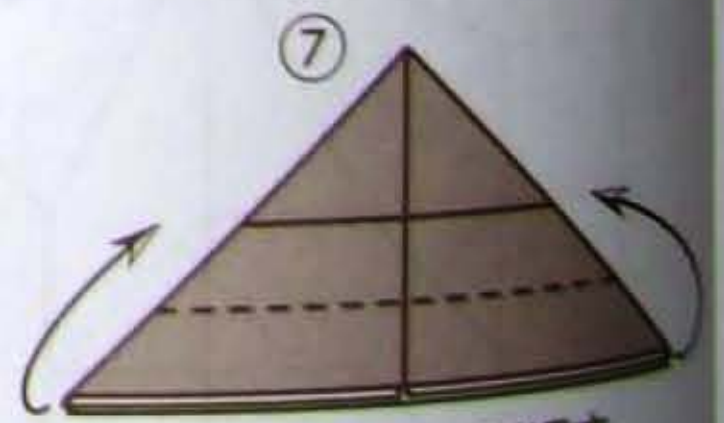

⑦ 前方をひっくり返す

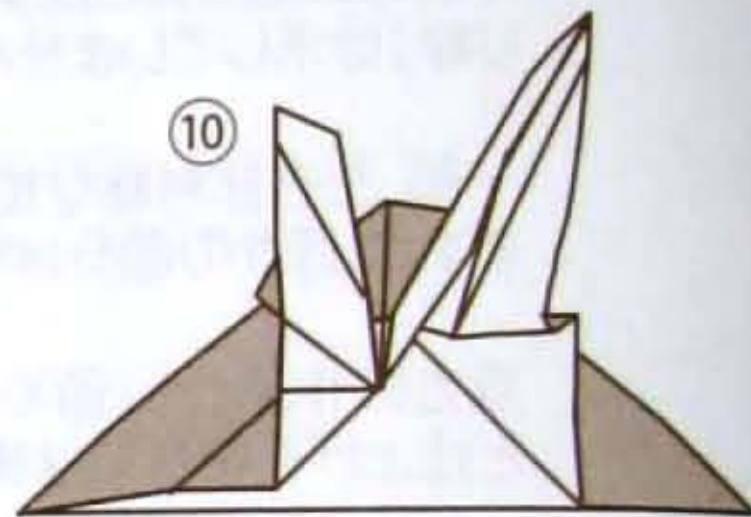

⑩ 途中図

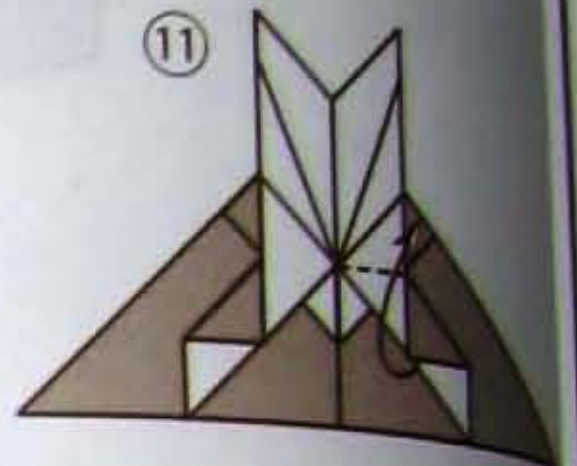

⑪ 開く

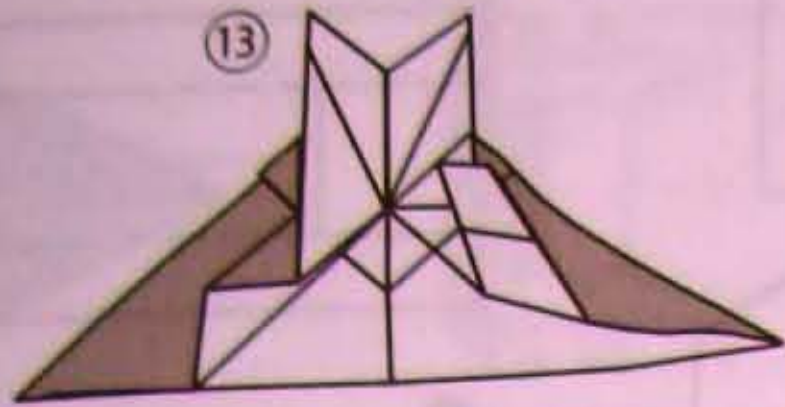

⑬ 反対側も折る

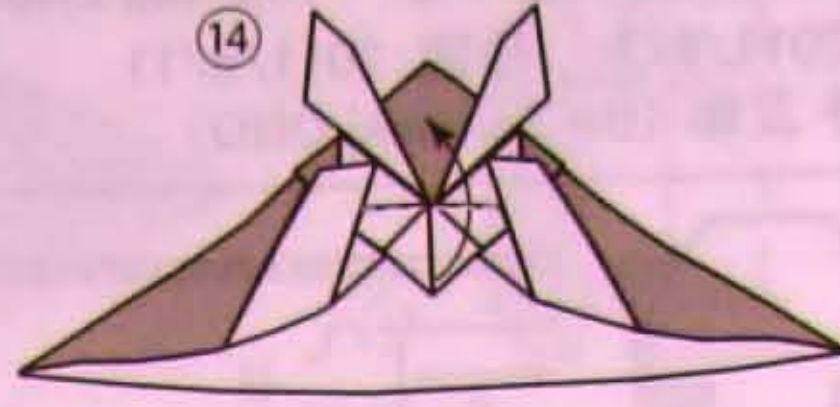

⑭ 谷折

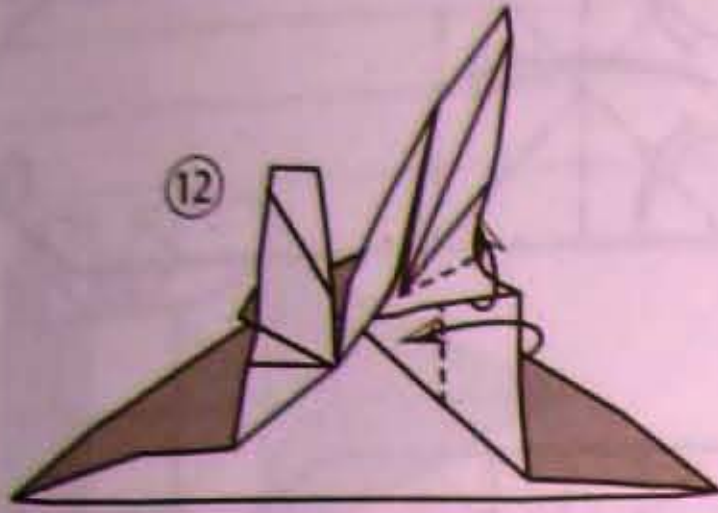

⑫ 複合折

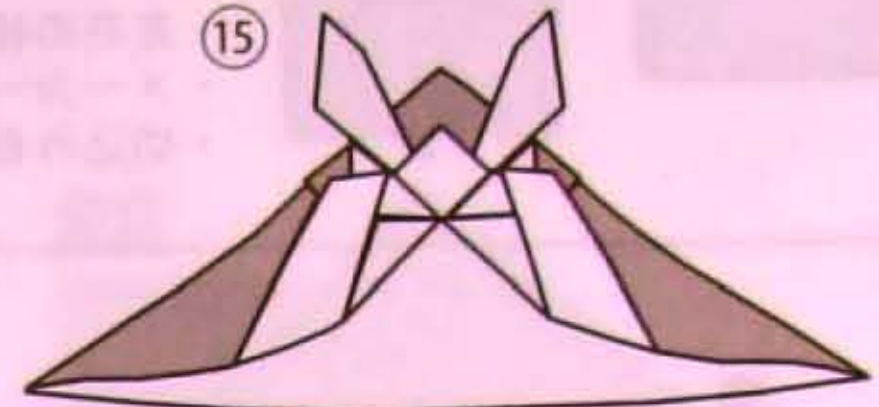

⑮ 正方基本形側に変える

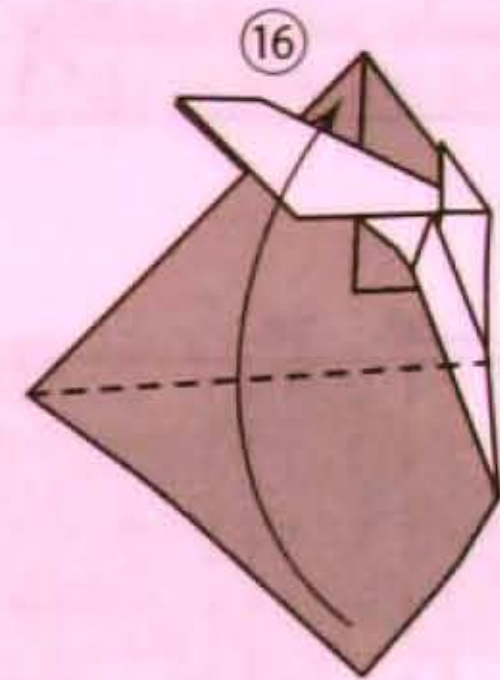

⑯ 谷折

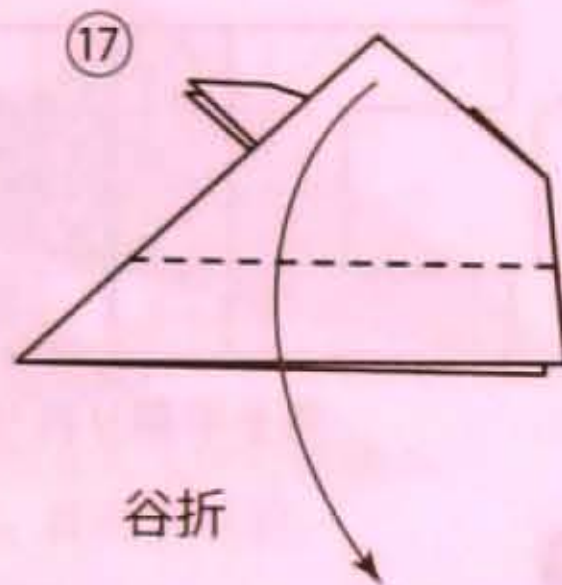

⑰ 谷折

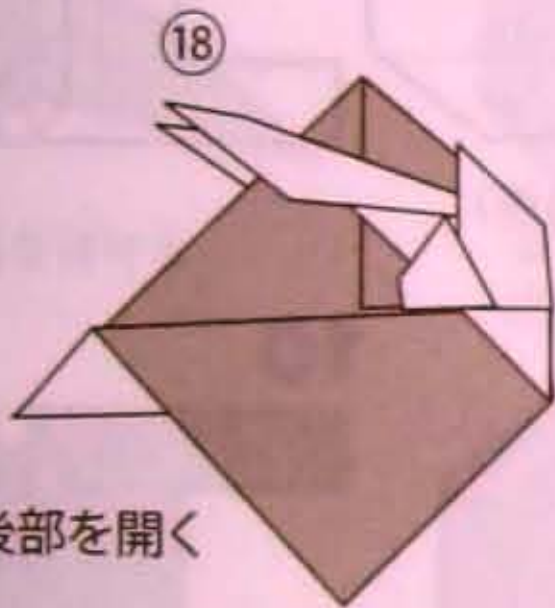

⑱ 後部を開く

Japão Burajirujin

www.japaoburajirujin.blogspot.com

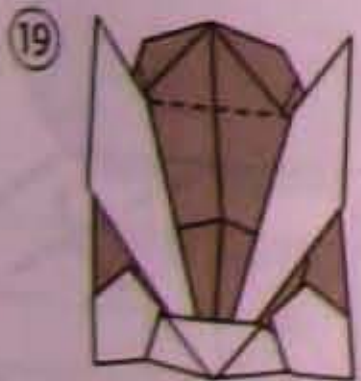

⑲ 複合折

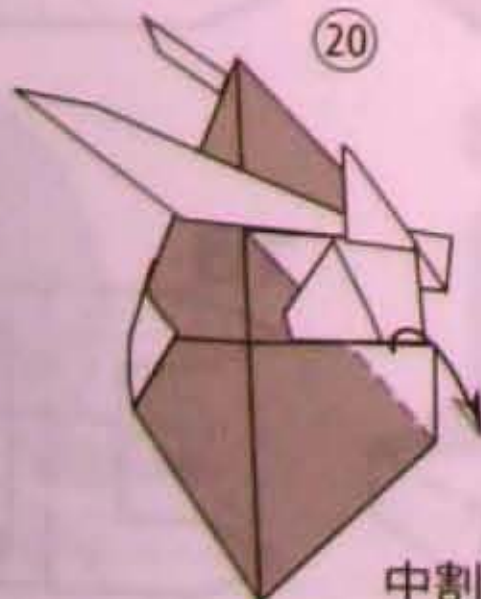

⑳ 中割り折

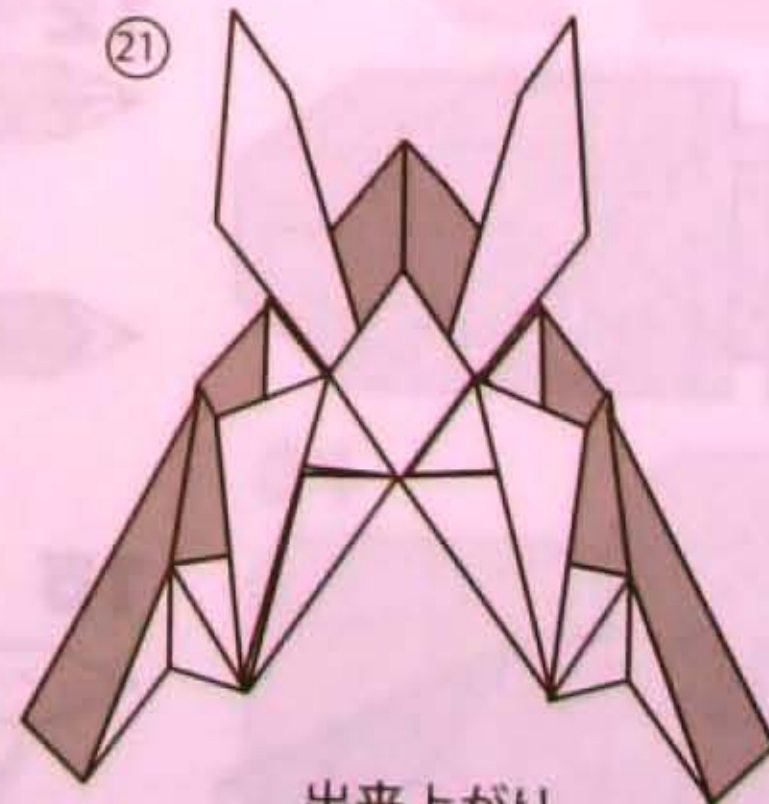

㉑ 出来上がり

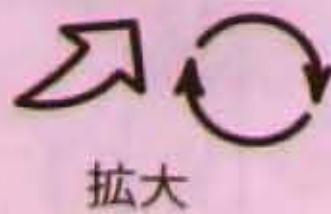

拡大

ティーバッグのゾウ Tea-bag Elephant

創作: 2011/6/7 作図: 2011/6/11
小野友彰 (By Tomoaki ONO)

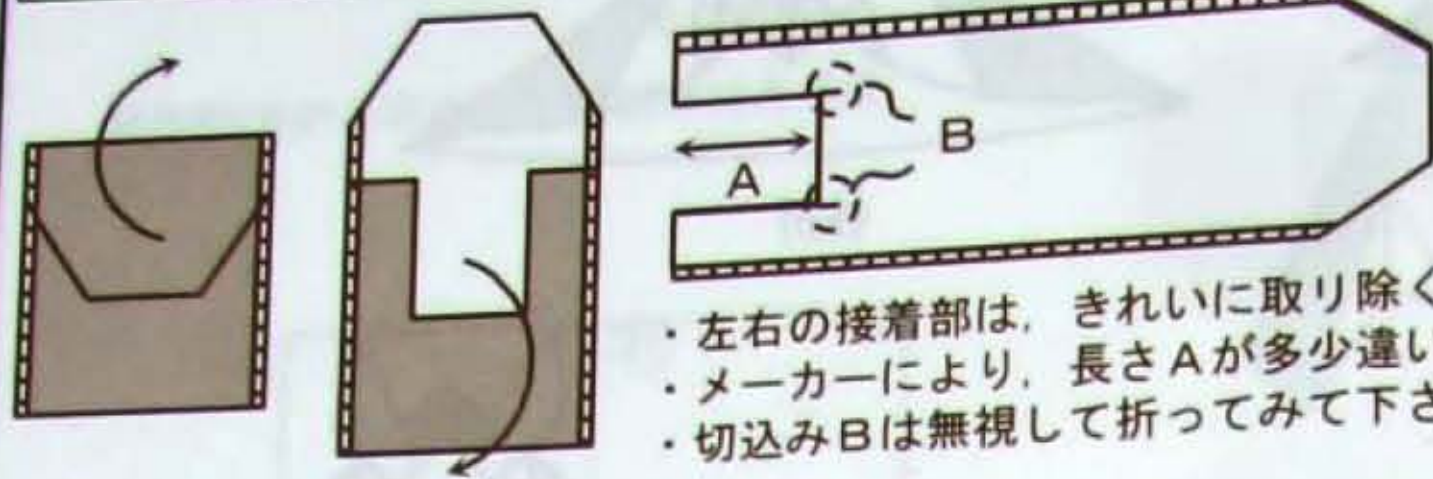

- ・左右の接着部は、きれいに取り除く。
- ・メーカーにより、長さAが多少違います。
- ・切込みBは無視して折ってみてください。

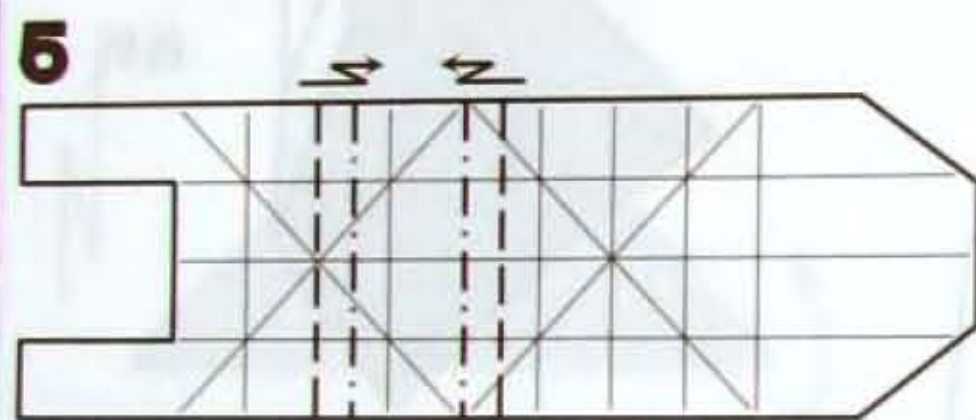
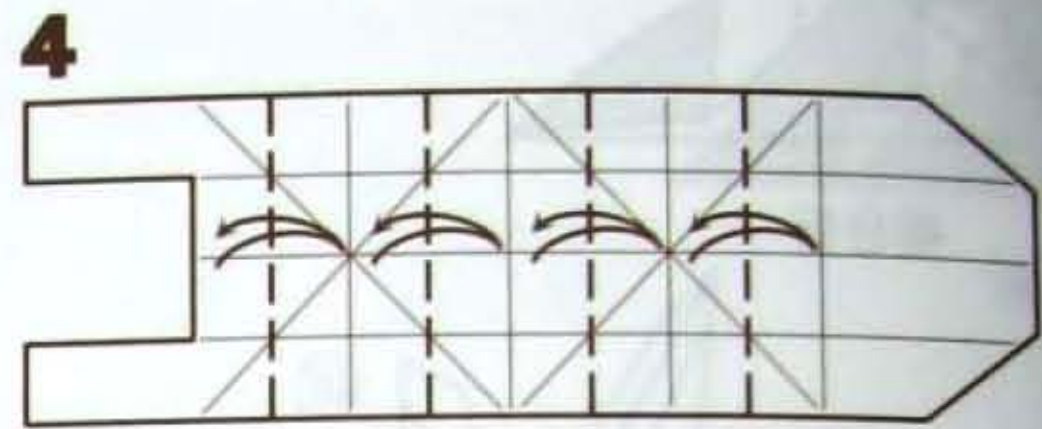
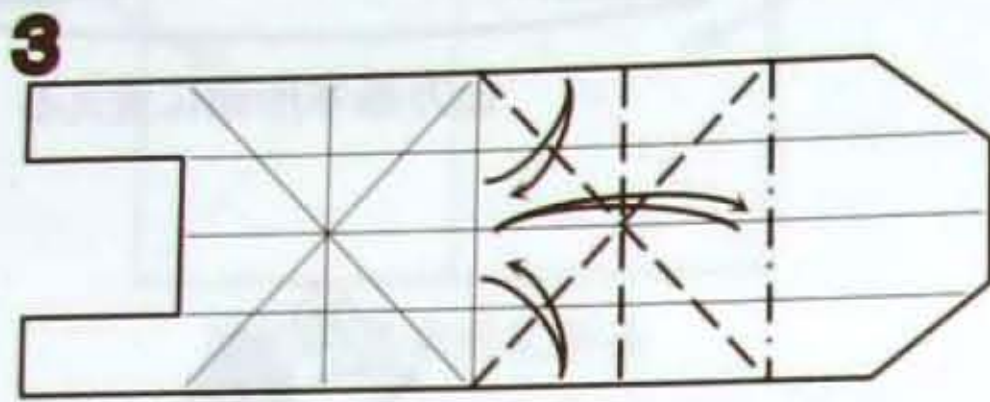
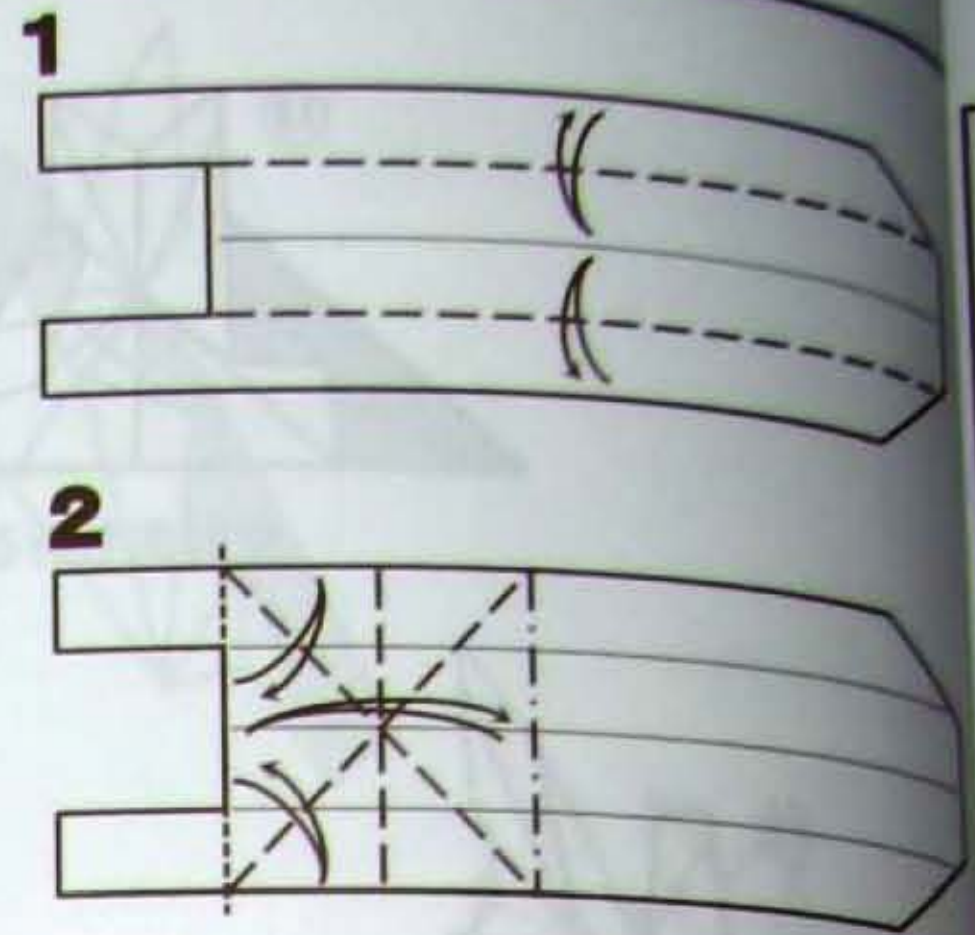

段折り (2箇所)

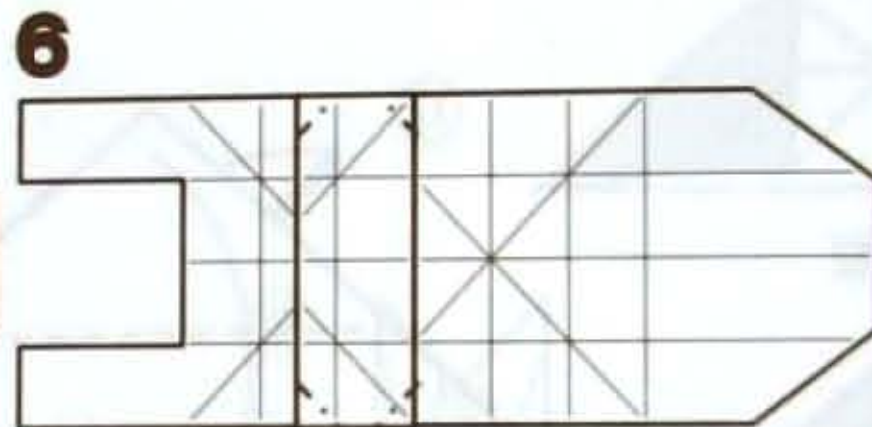

角を中割り折り (4箇所)

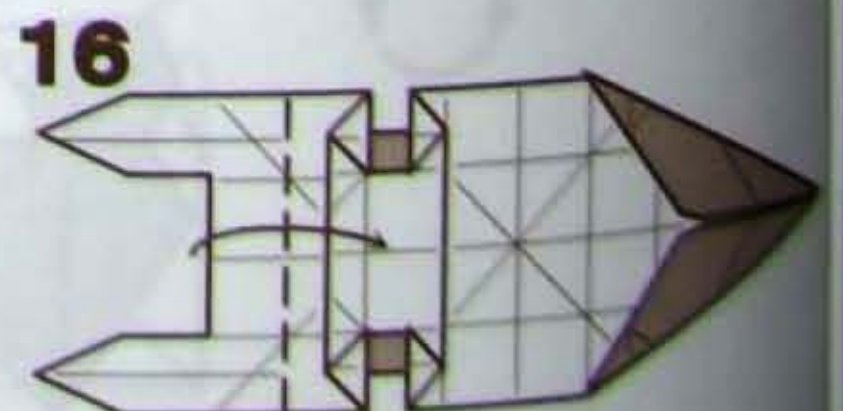
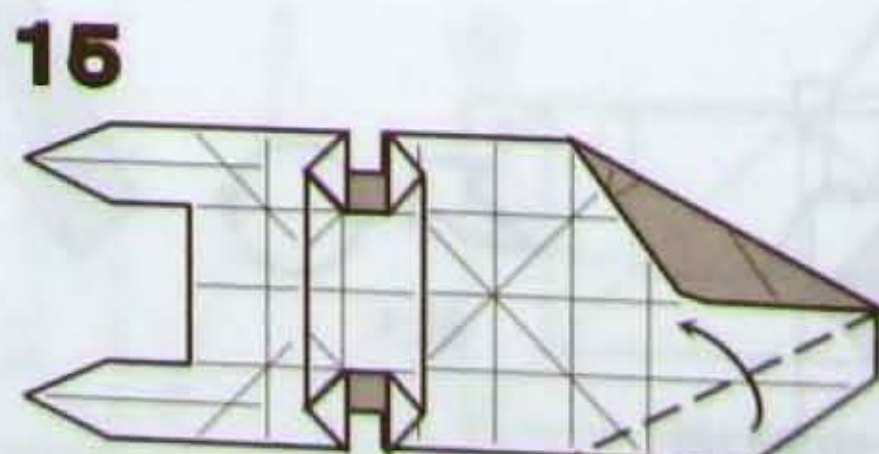
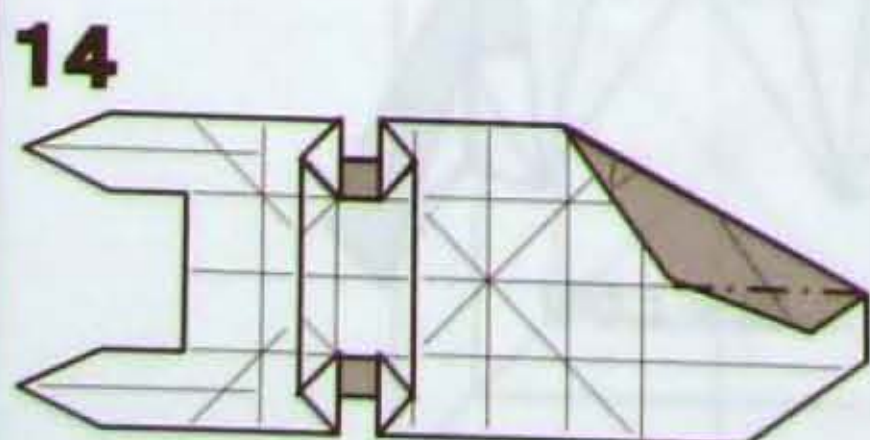
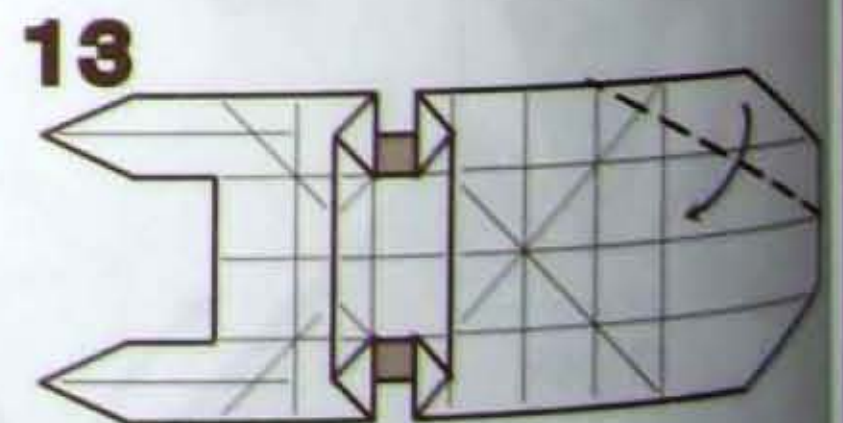
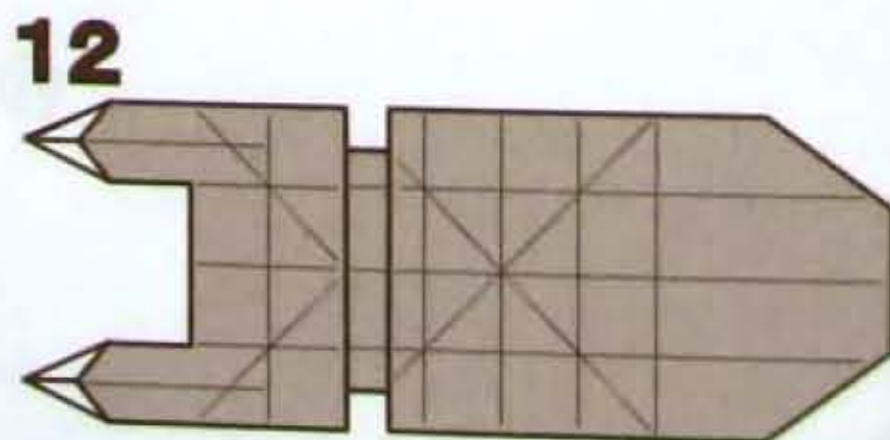
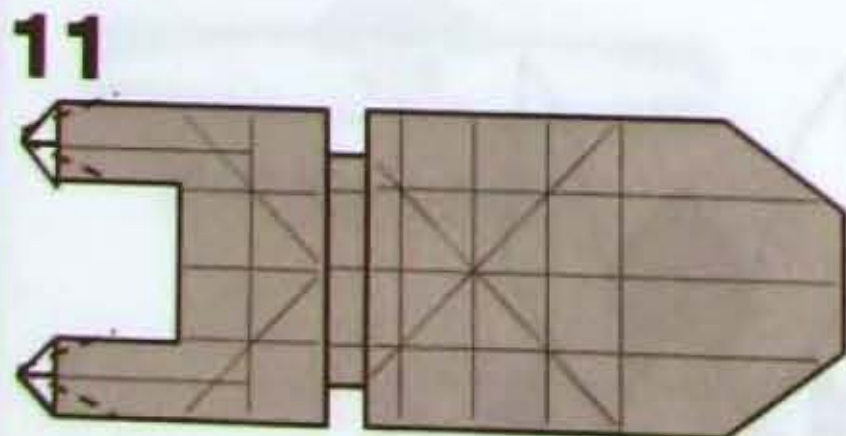
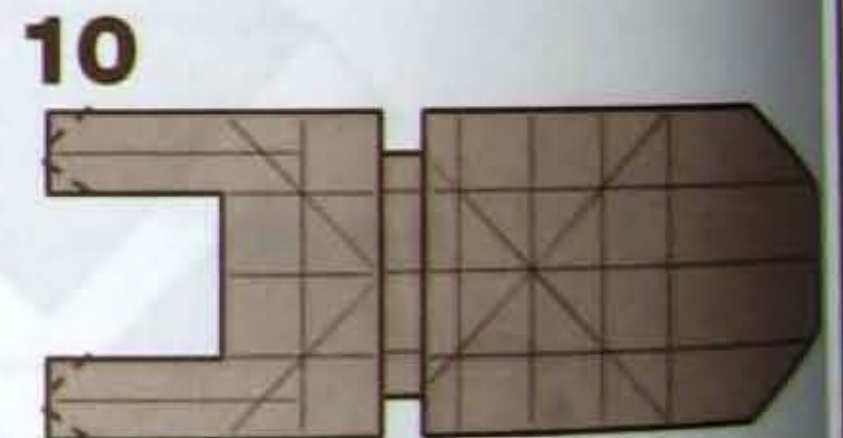
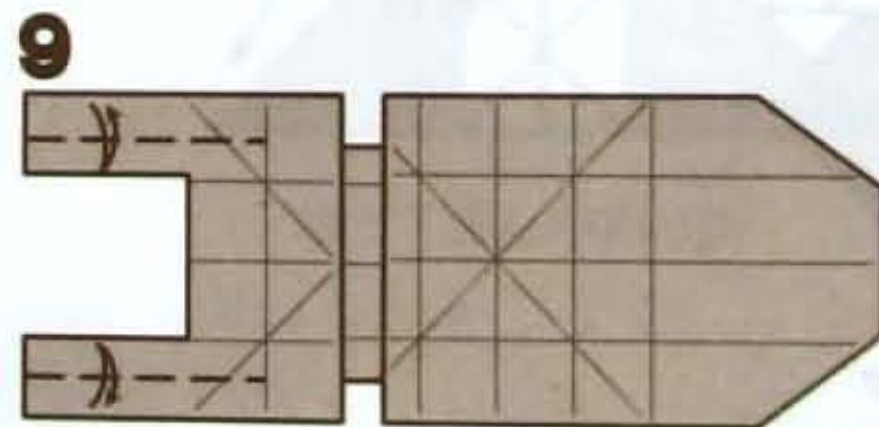
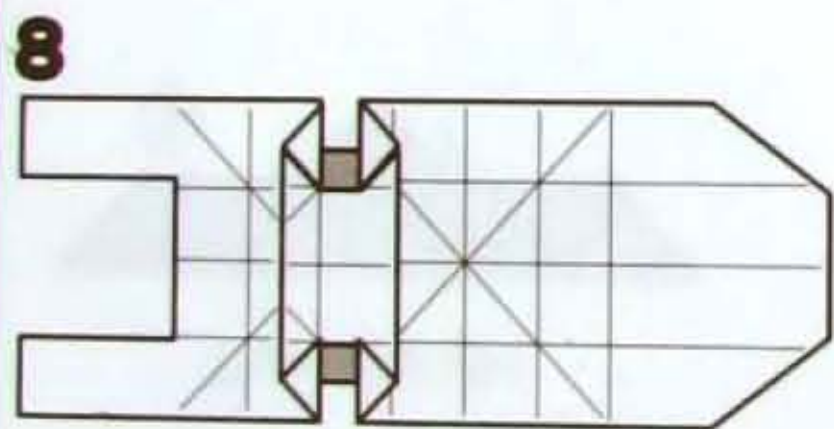
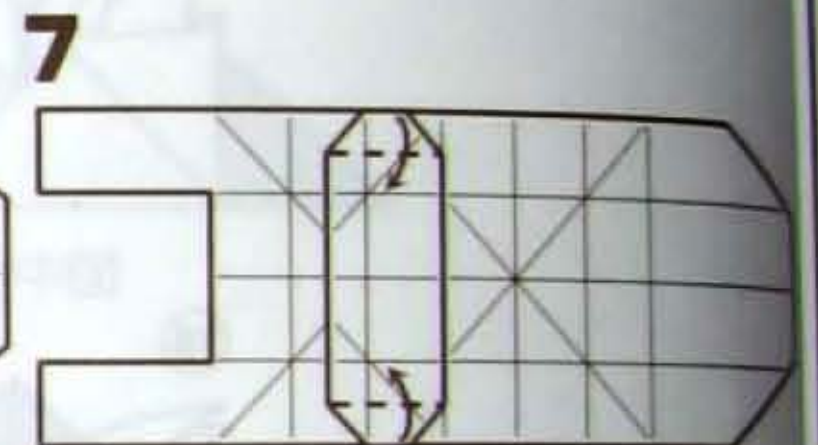

反対側も同じ

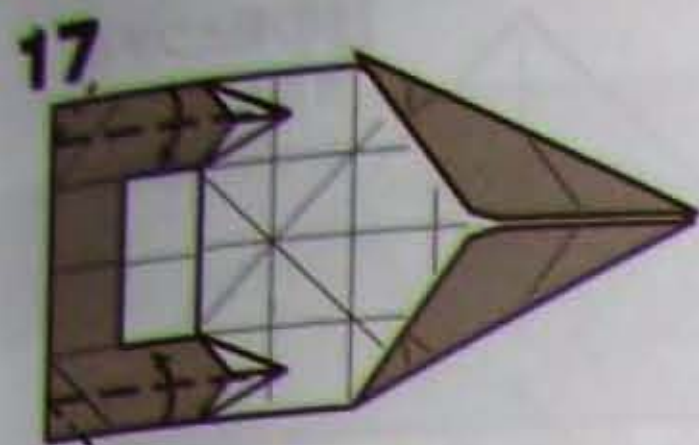

17
根元を開いて潰して
半分幅にする

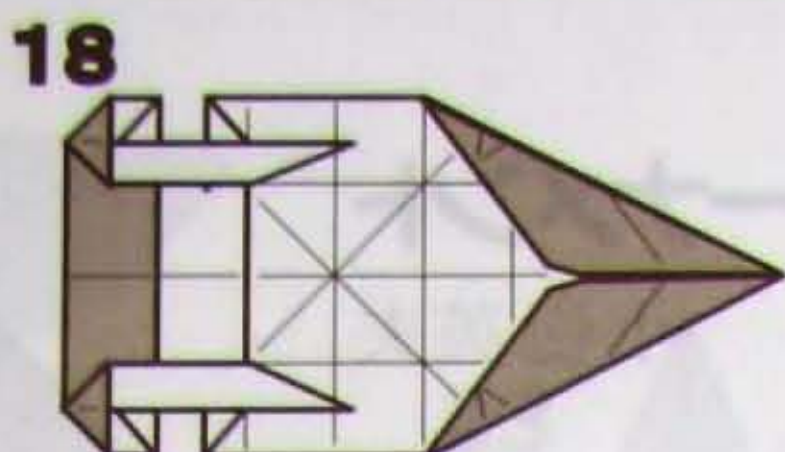

18
ひだの内側に入れ替える

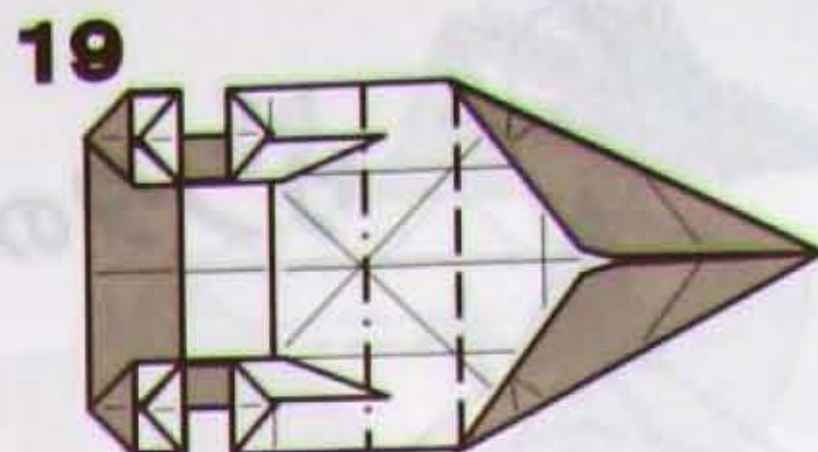

19

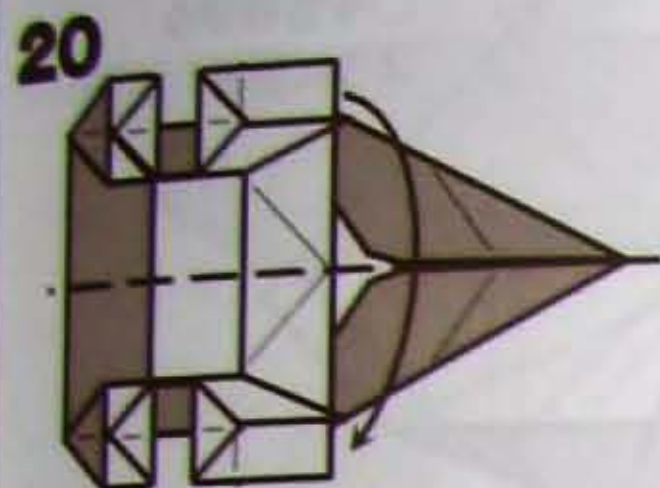

20
全体を半分に折る
次から少し図を拡大

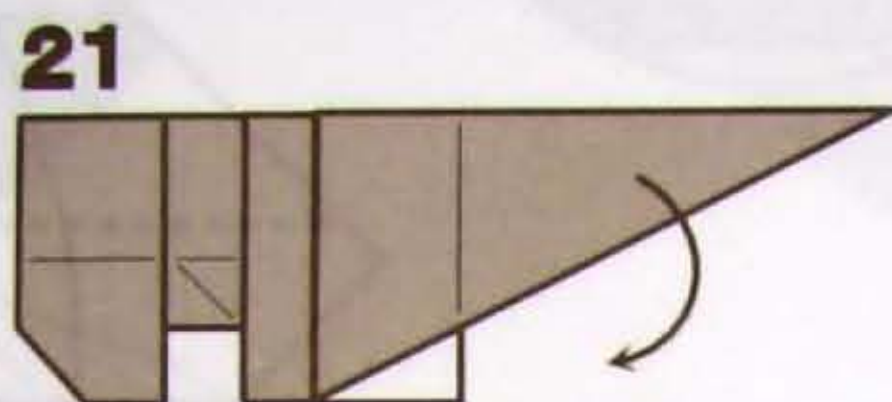

21
三角部分を回転させる
目安は次図を参照

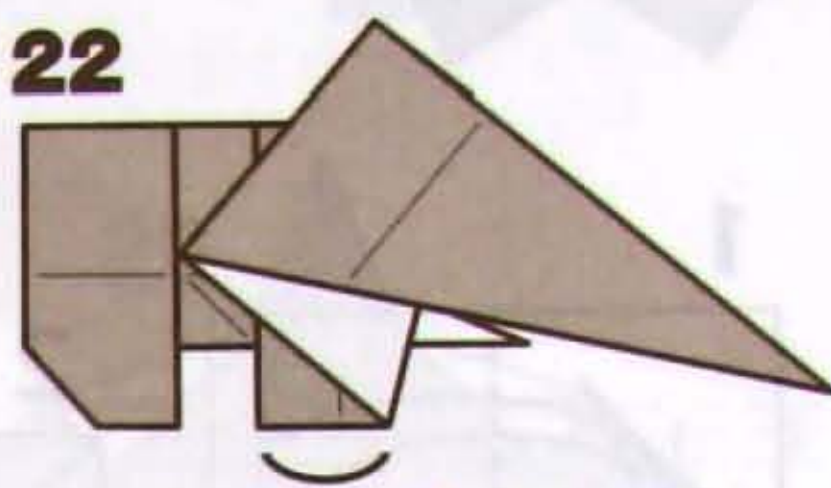

22
この幅が大きくなり過ぎると
バランスが悪くなるので注意

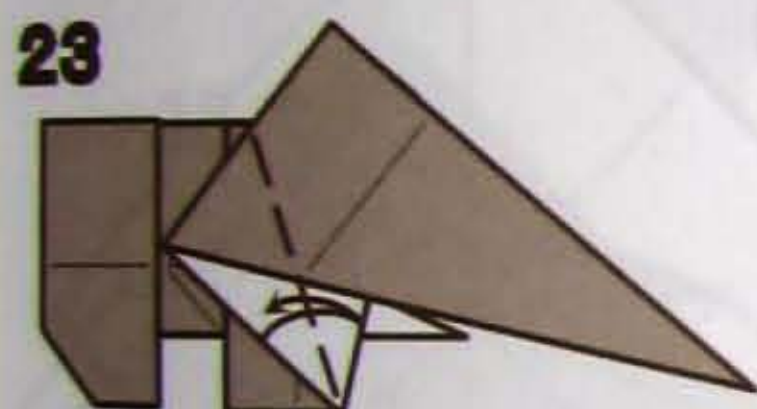

23
縁を合わせて折り筋を付ける
反対側も同じ

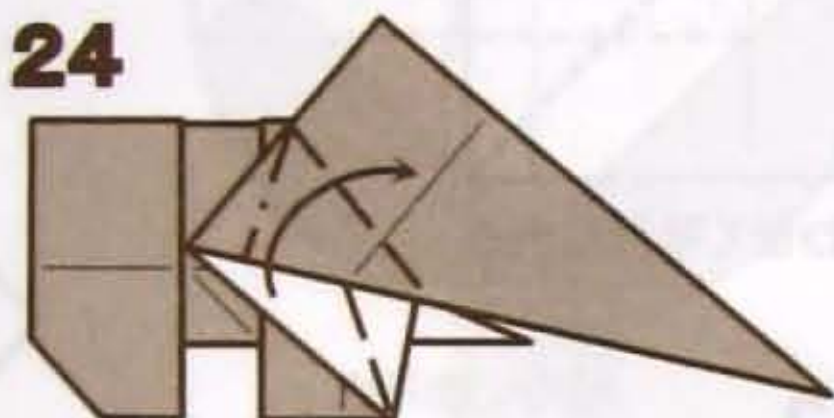

24
谷折り線で立ち上げて逆側へ
折り返す。反対側も同

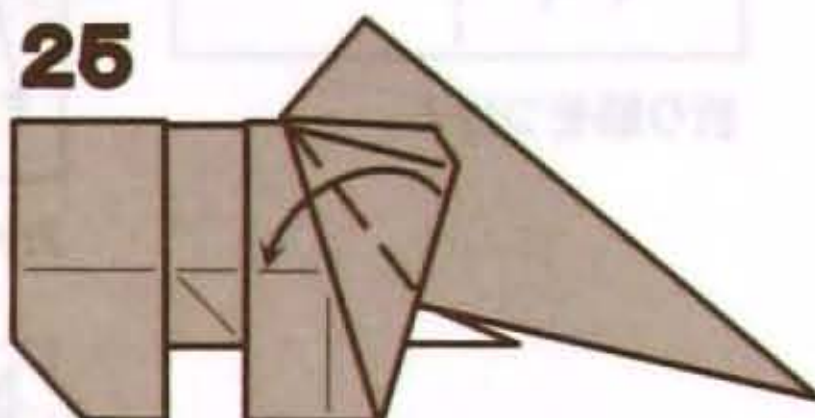

25
いっぱいのところまで折り返す
反対側も同じ

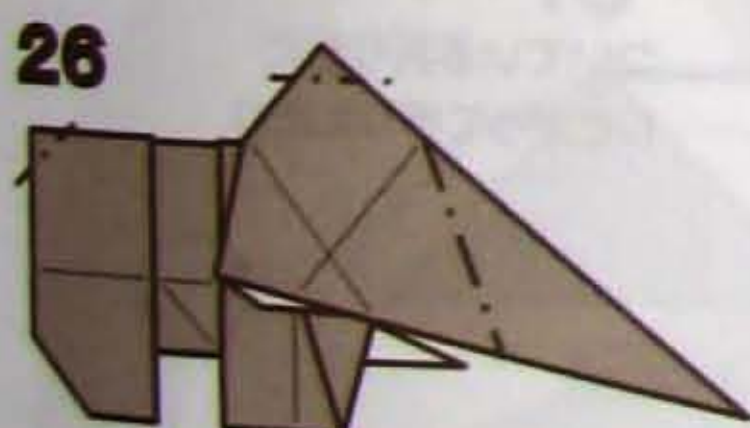

26
中割り折り (3箇所)



27
細く谷折り
反対側も同じ

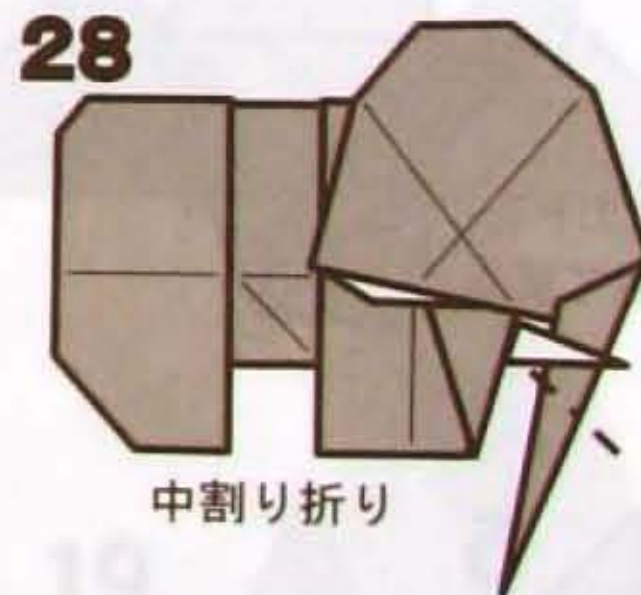

28
中割り折り

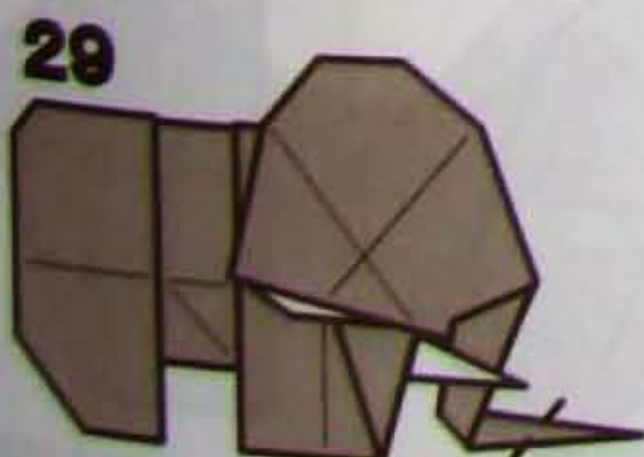

29
かぶせ折り

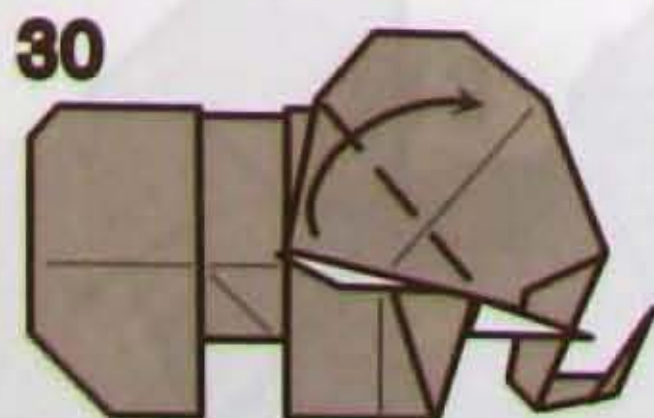

30
耳を少し立てる

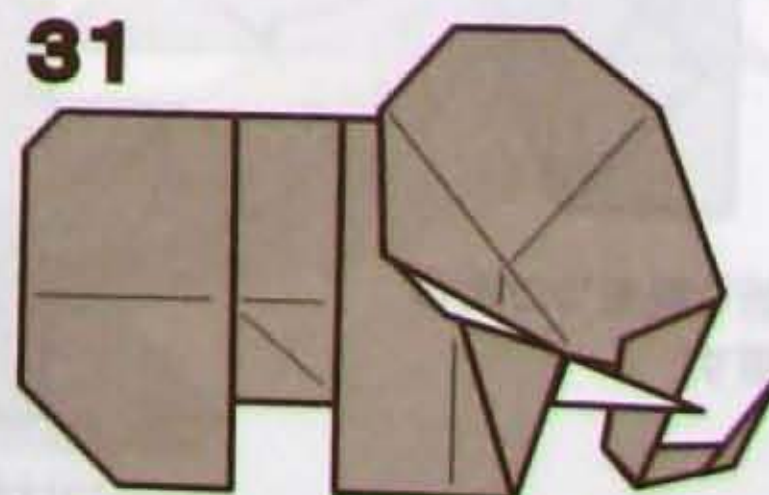

31
できあがり

サンタのオーナメント

小松英夫

Santa Claus Ornament
by Hideo Komatsu, 2010



1

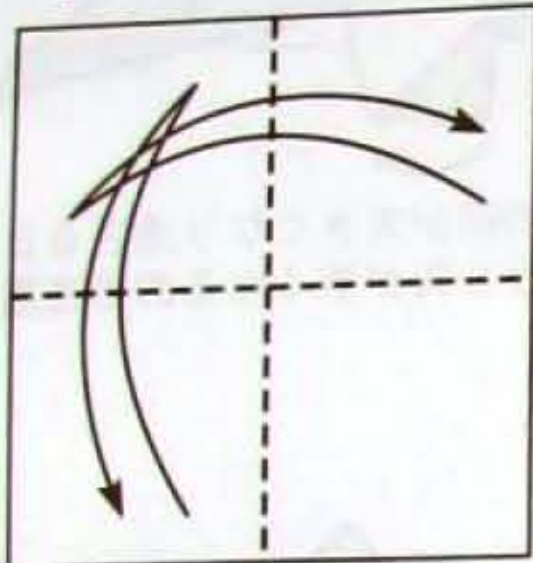

折り筋をつける

2

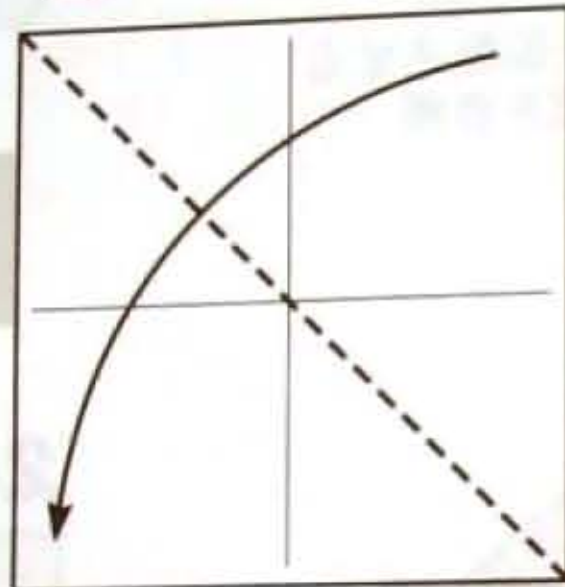

カドを合わせて半分に折る

4

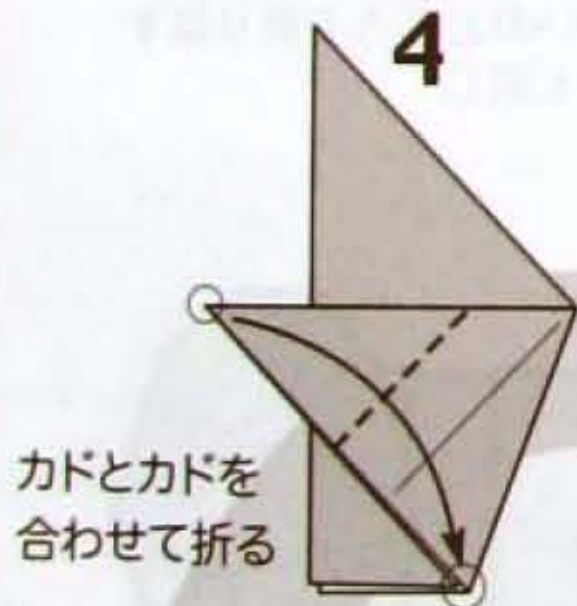

カドとカドを
合わせて折る

3

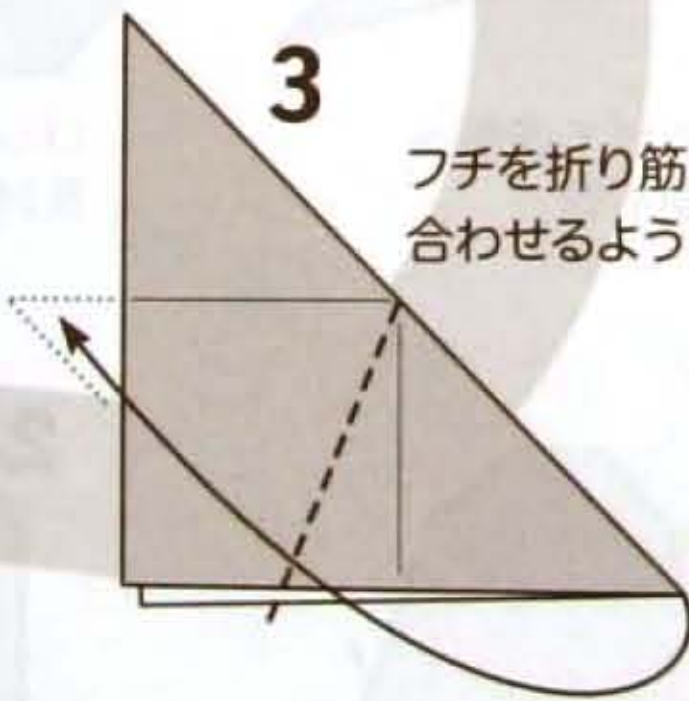

フチを折り筋に
合わせるように折る

5

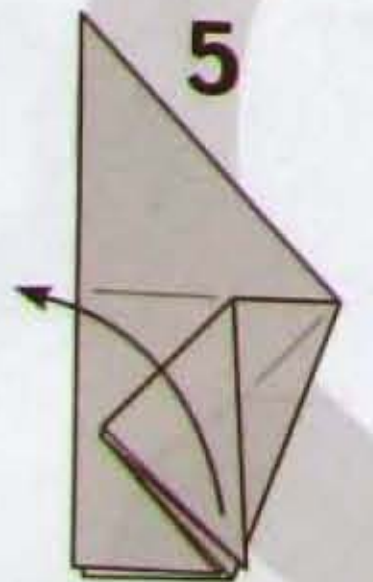

折り筋をついたら
戻す

6

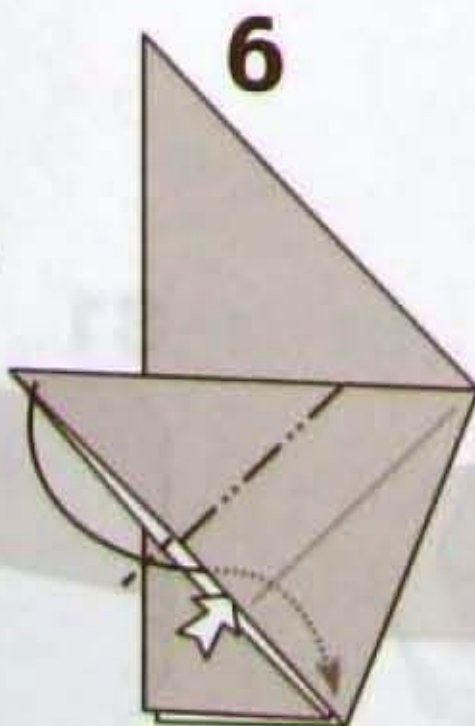

つけた折り筋で
中割り折り

7

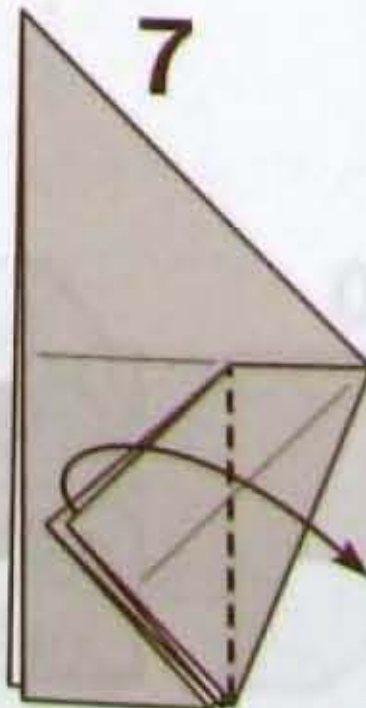

ひらくところで
折り返す

8

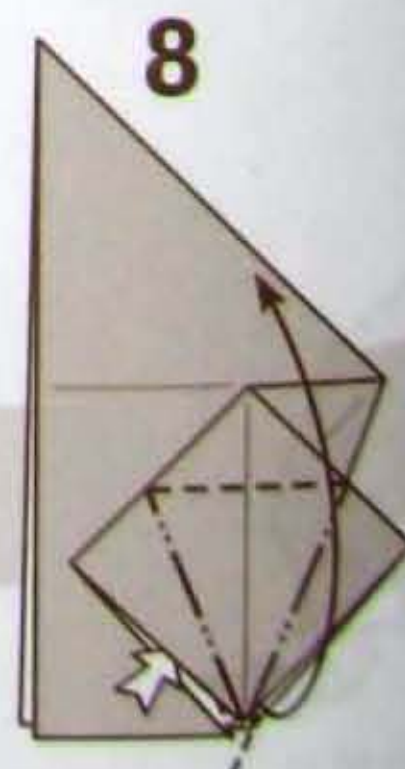

花弁折り

9



すべてひろげる

12

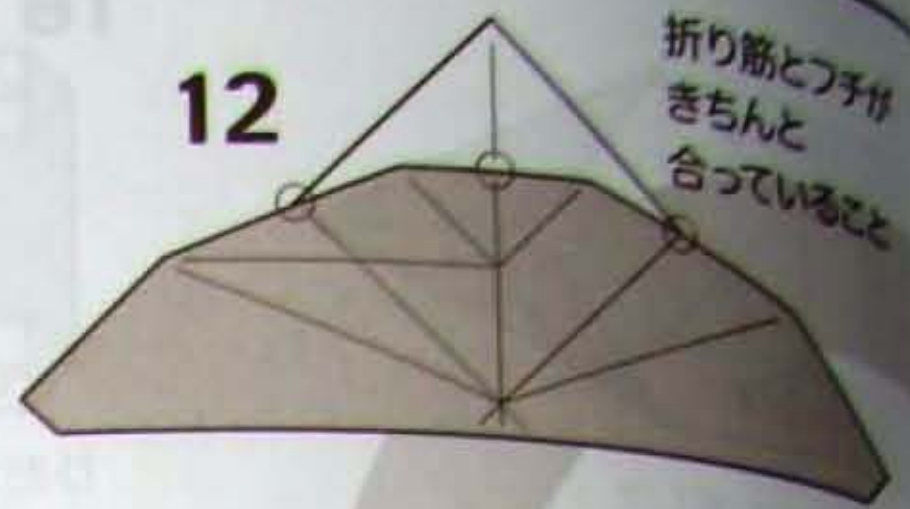

折り筋とフチが
きちんと
合っていること

11

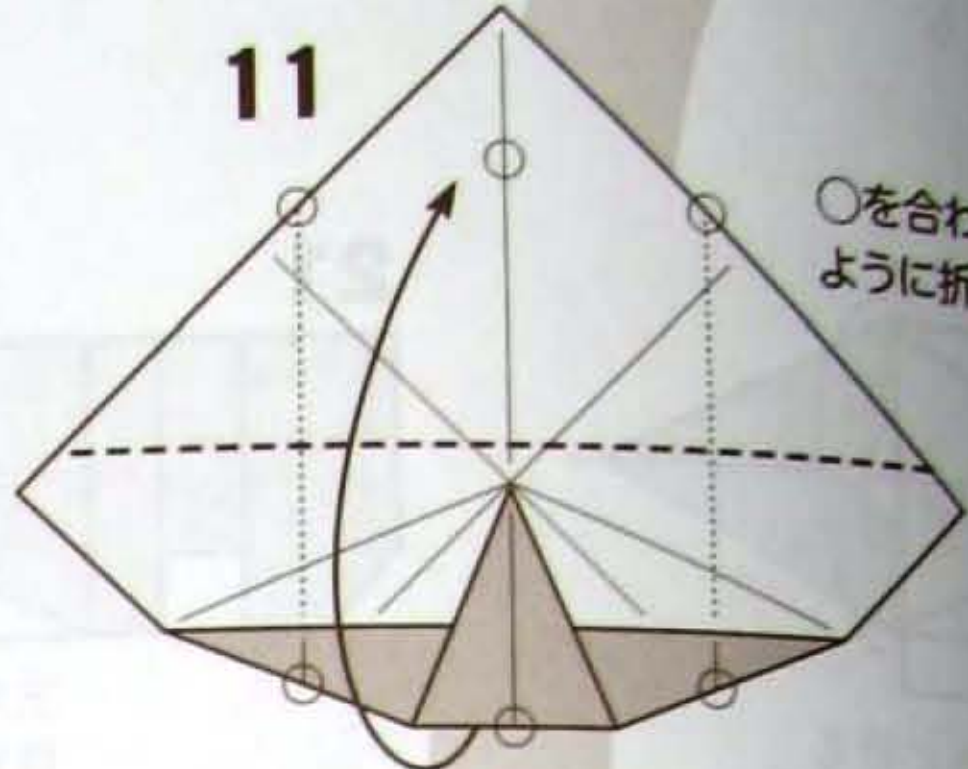

○を合わせる
ように折る

10

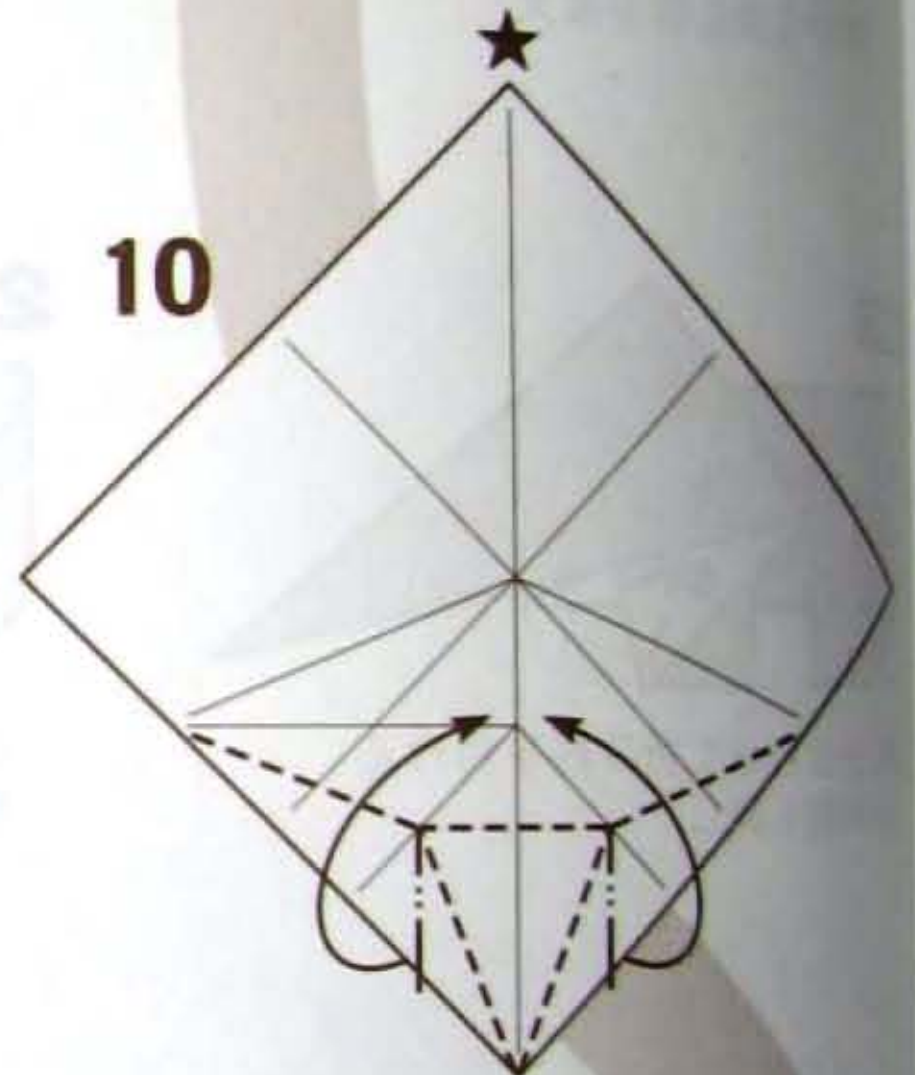

ついている折り筋に
したがって折りたたむ

13

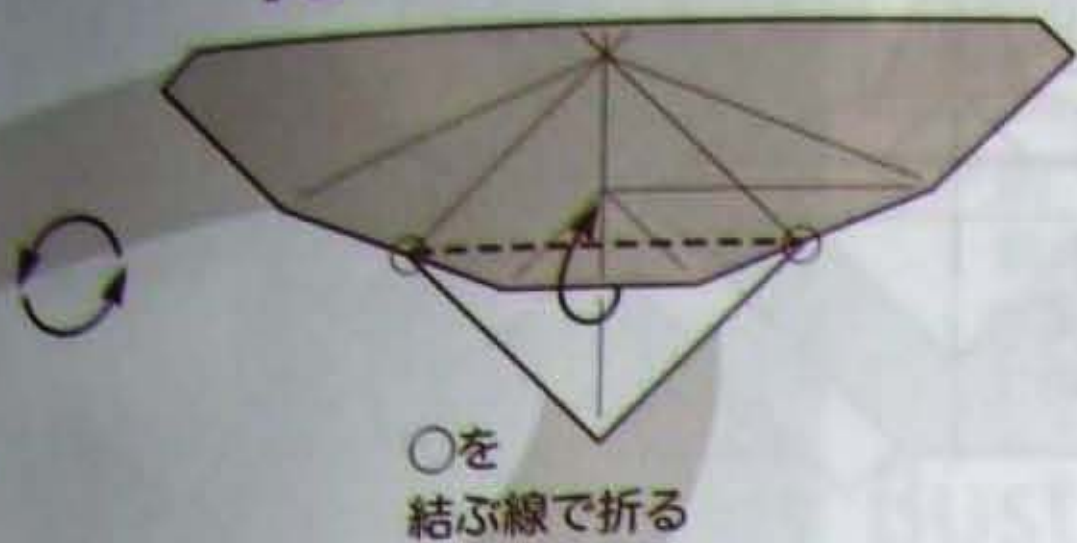

○を
結ぶ線で折る

14

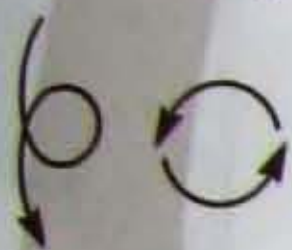
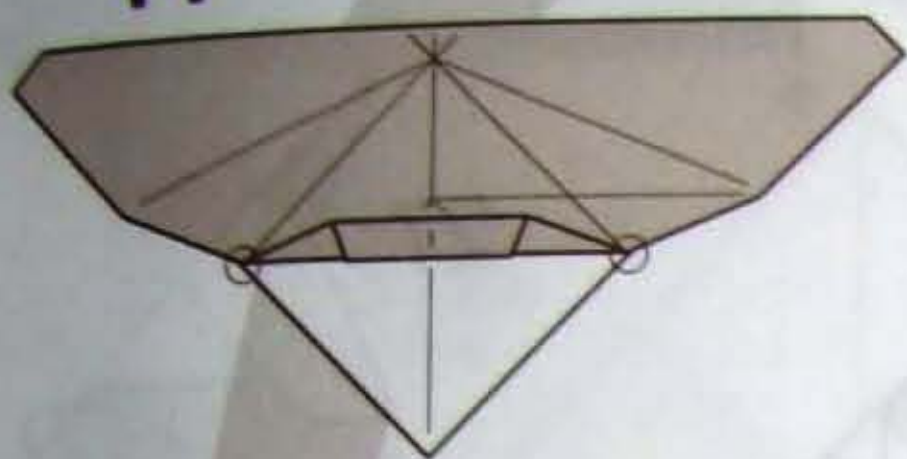

15

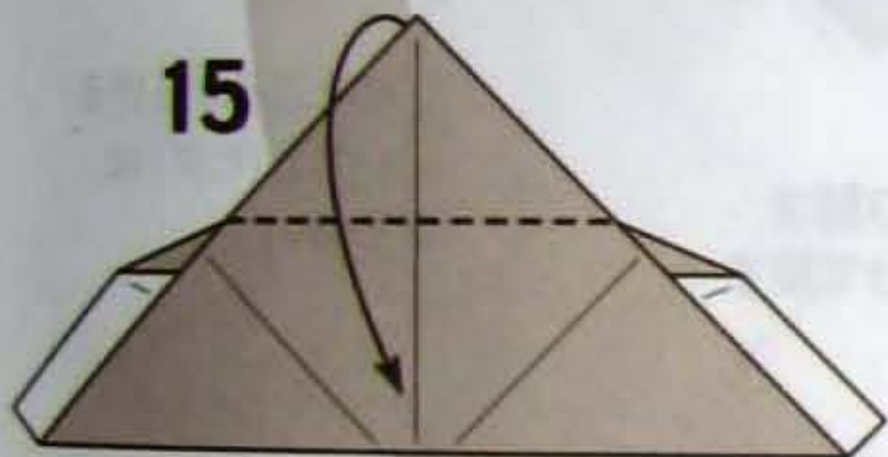

後ろにあるフチに
沿って折る

16

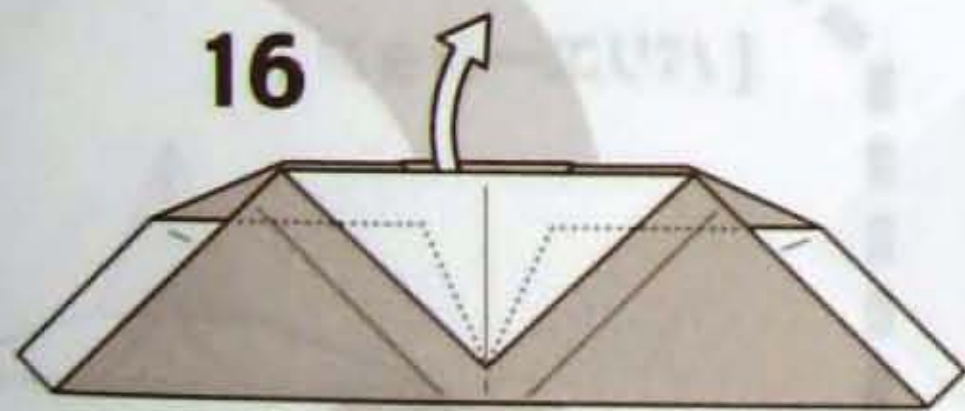

間にあるカドを引き出す

17

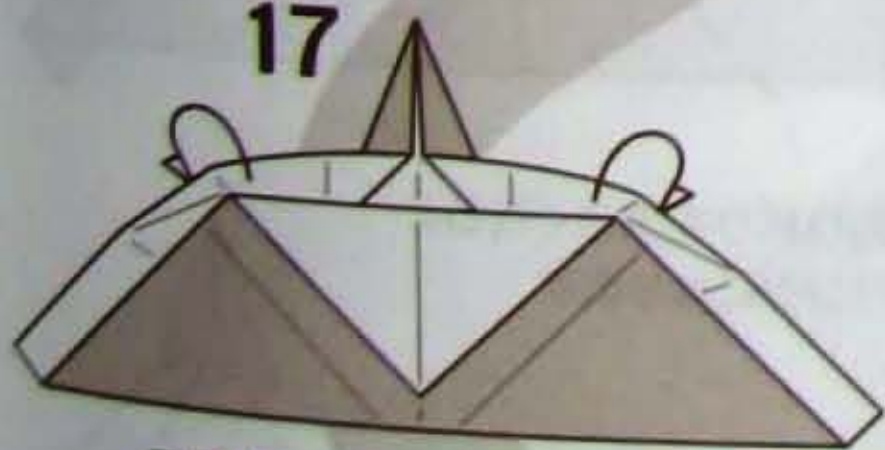

フチを向こう側に
ひっくりかえすようにする

23

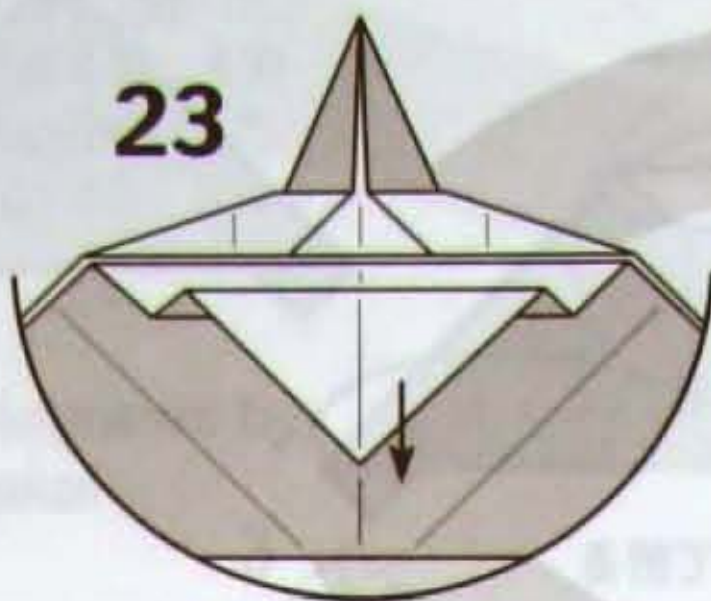

21

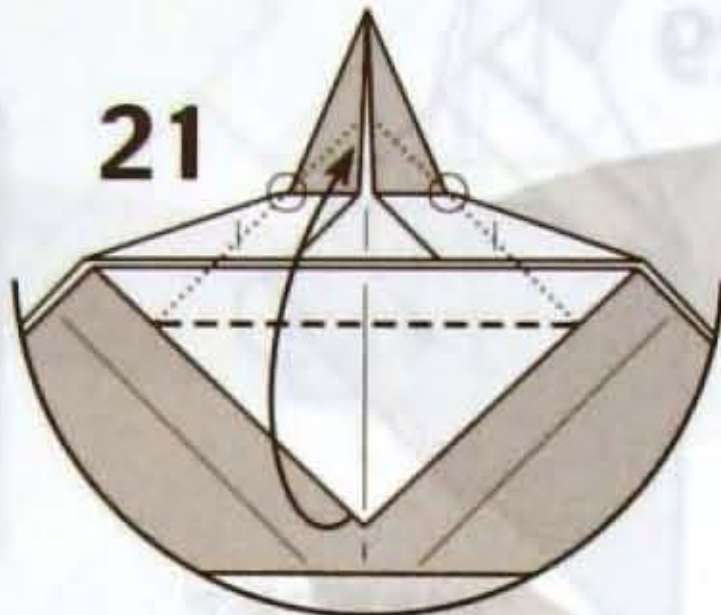

カドのフチが
○を通るように折る

20

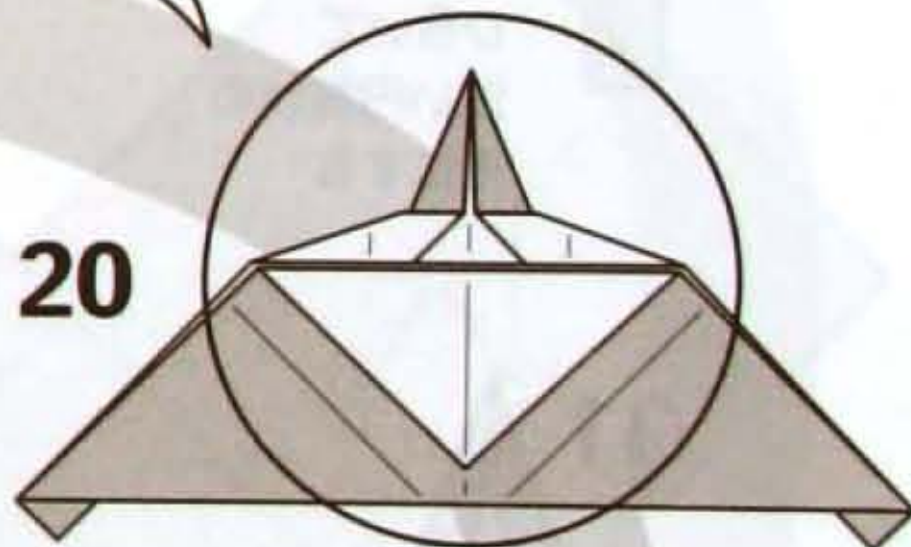

19

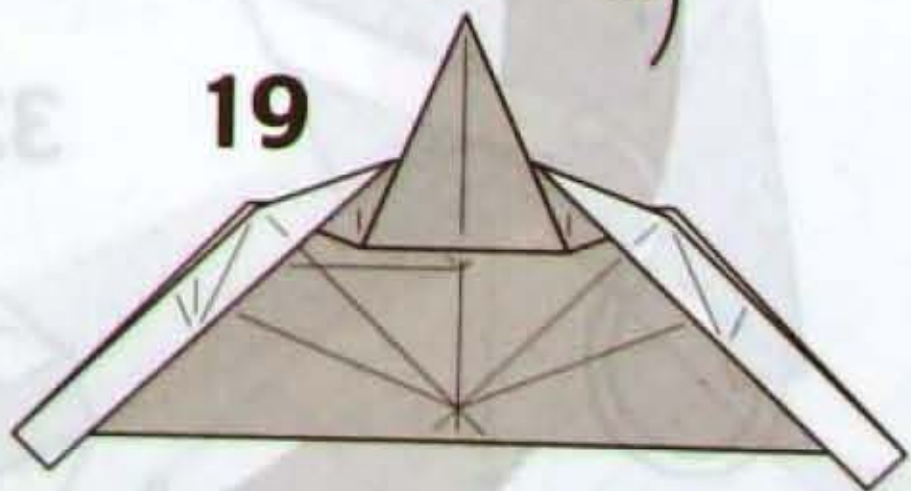

18

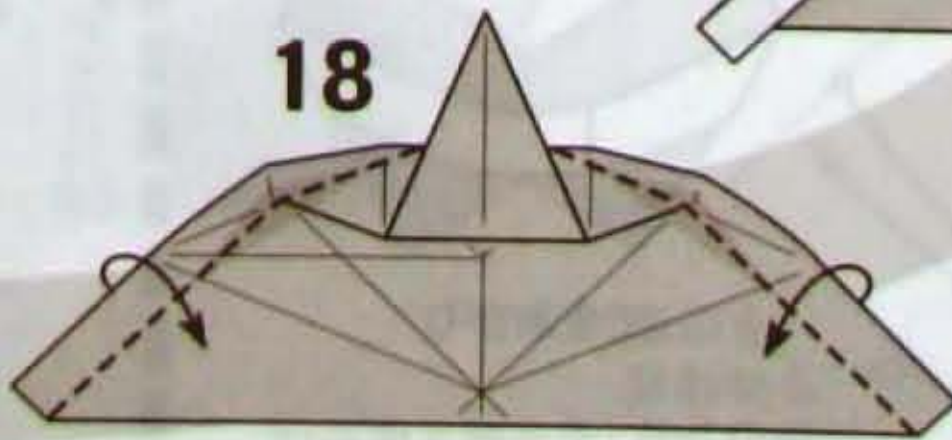

17でひっくりかえした部分を
後ろにあるフチに沿って折りたたむ

24

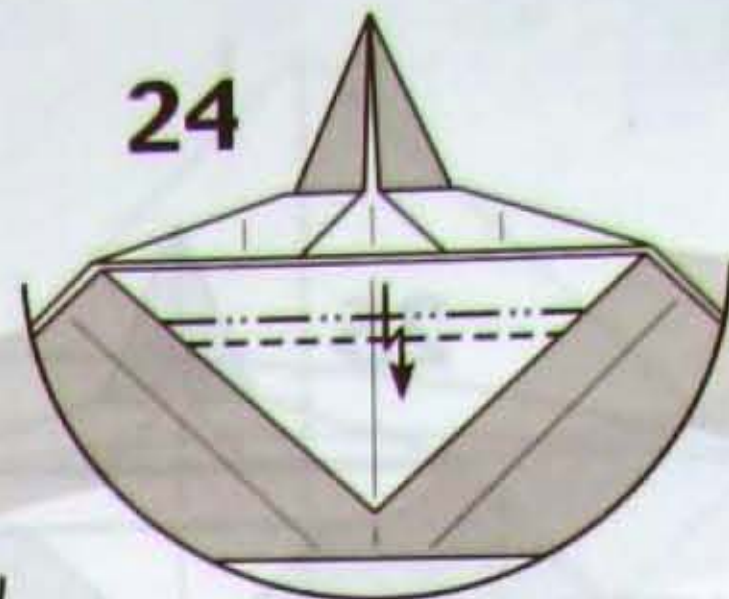

折り筋の
山谷を逆にして
段折り

22

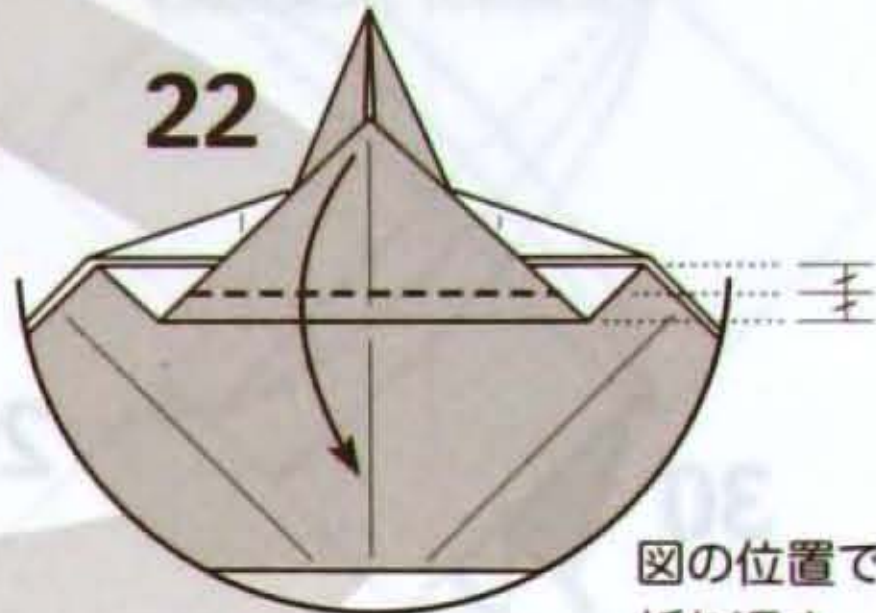

図の位置で
折り返す

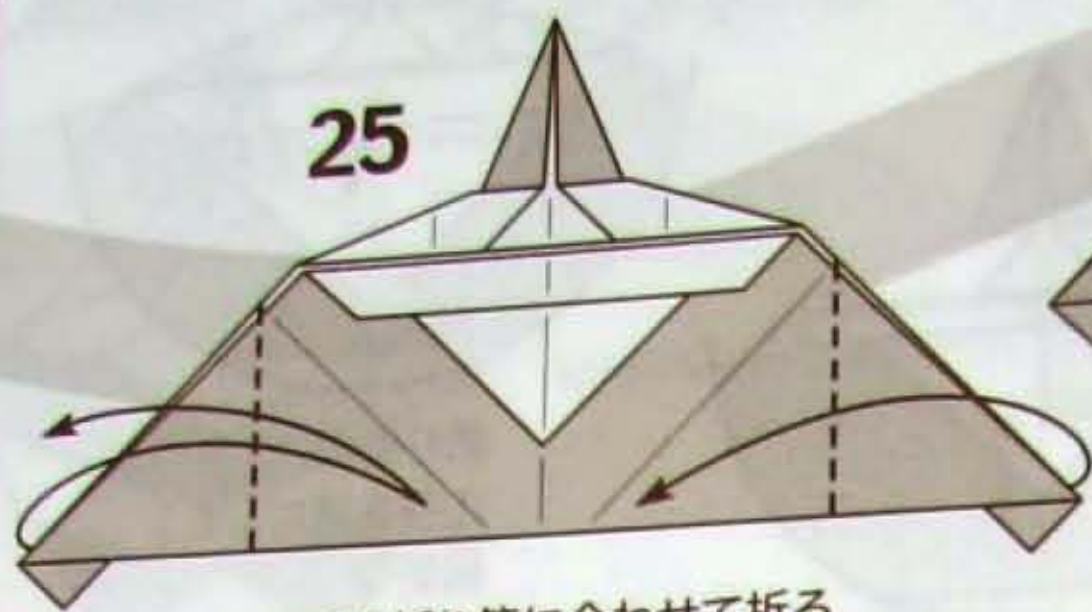

フチを折り筋に合わせて折る
左側は折った後に戻す

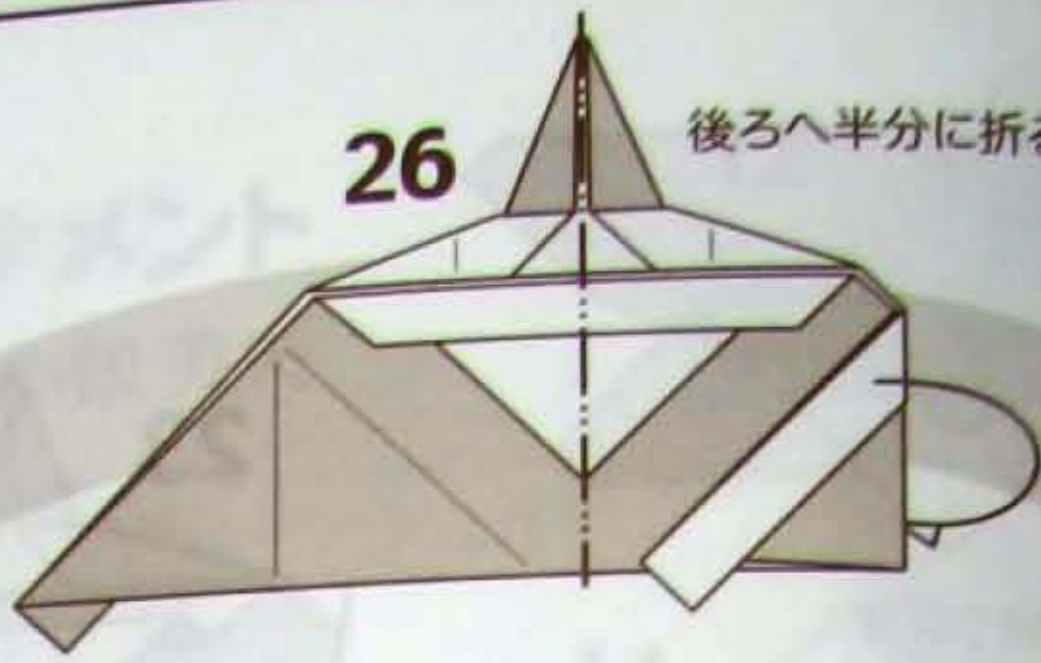

26 後ろへ半分に折る

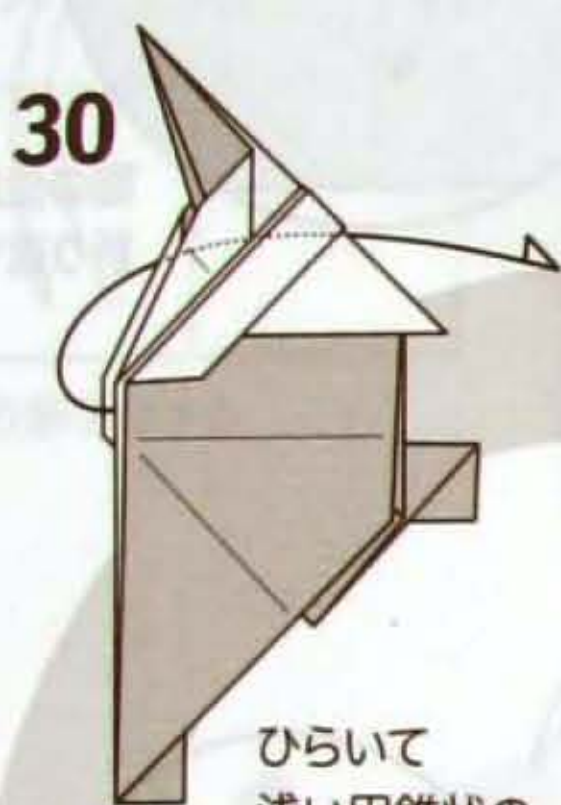

ひらいて
浅い円錐状の
形にする

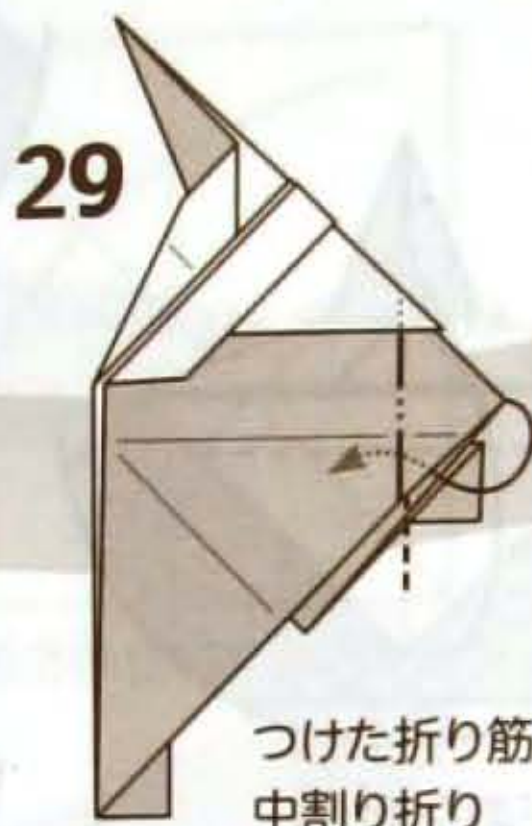

つけた折り筋で
中割り折り

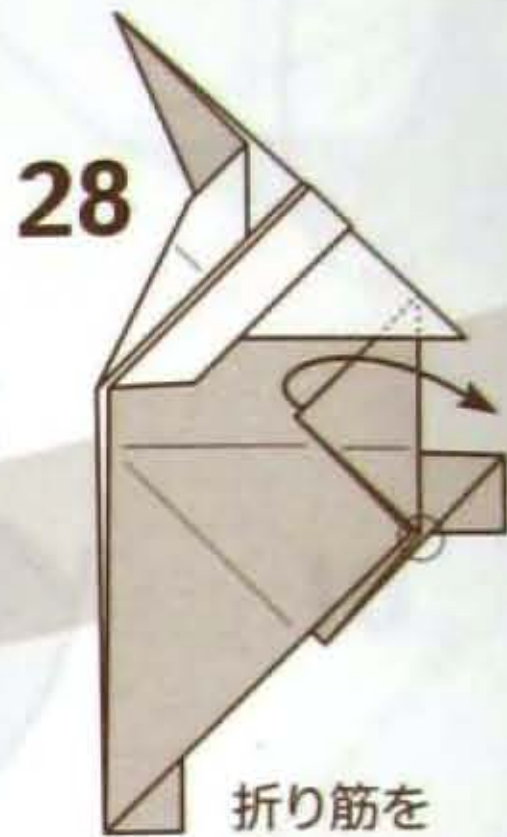

折り筋を
つけて戻す

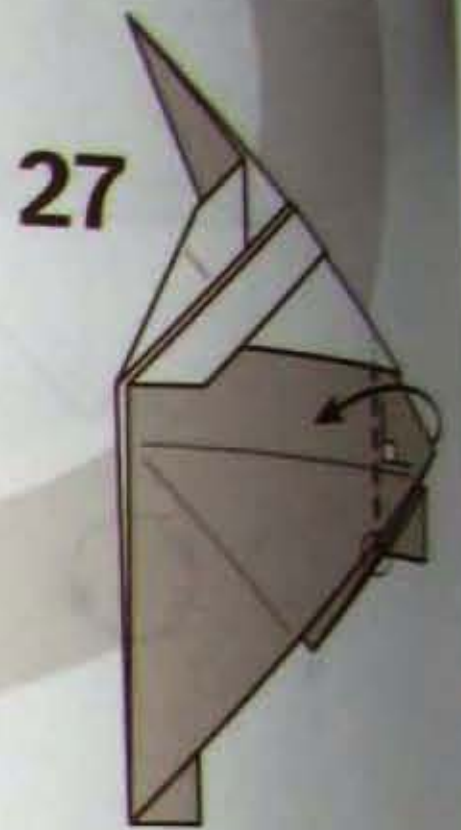

○のところから折る
白いカド(ヒゲ)は
折らない



すき間に差し込んで
組み合わせる



できあがり

自立しないので飾る場合は
工夫が必要です

[バリエーション]

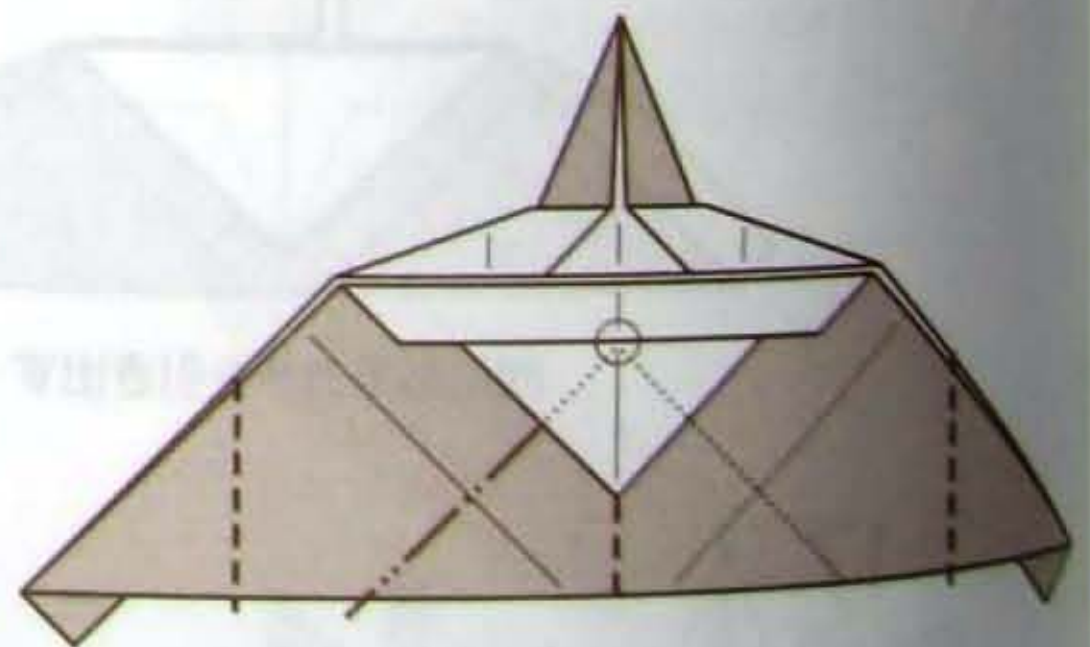

お腹の中割り折りを大きく取ると
背が高いサンタになります

さらに
腕のところで
段折りしたり



胸像

作/図 中井 努

創作 2007年 6月

作図 2007年 8月

改作 2011年 5月

Bust

Model & Diagrams by
Tsutomu Nakai

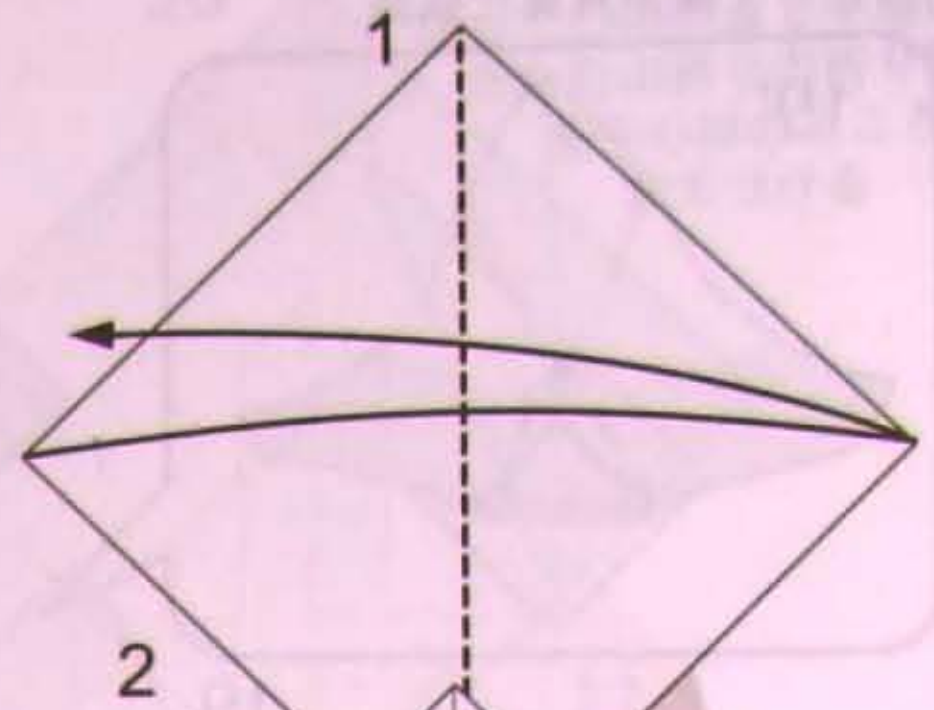
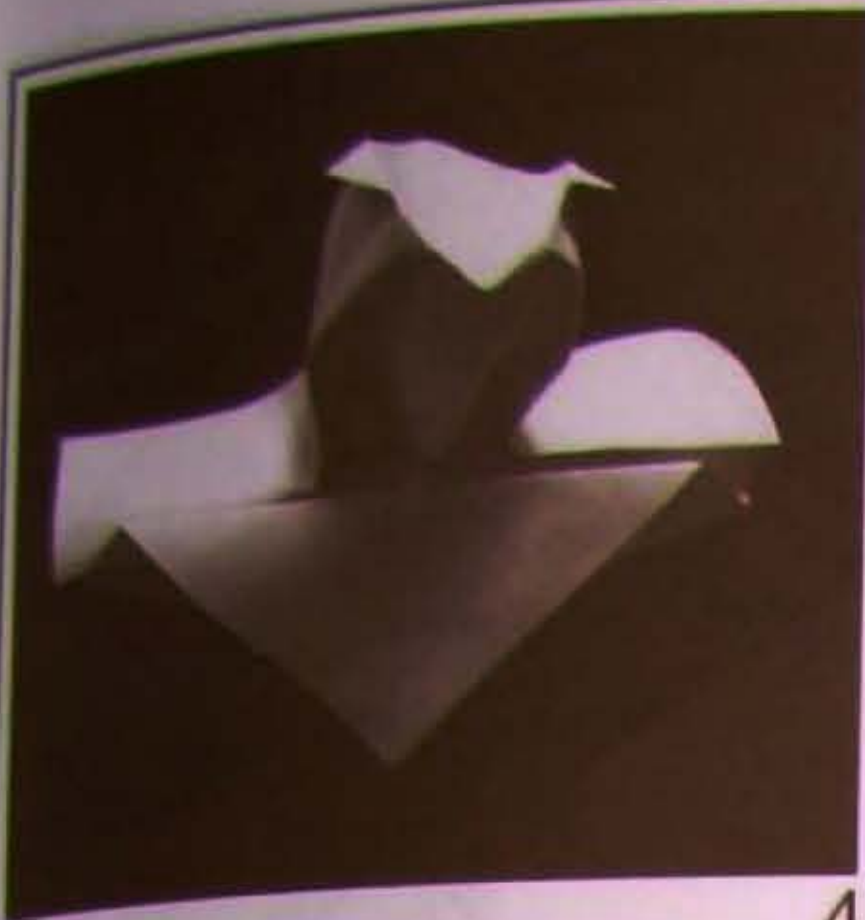

2

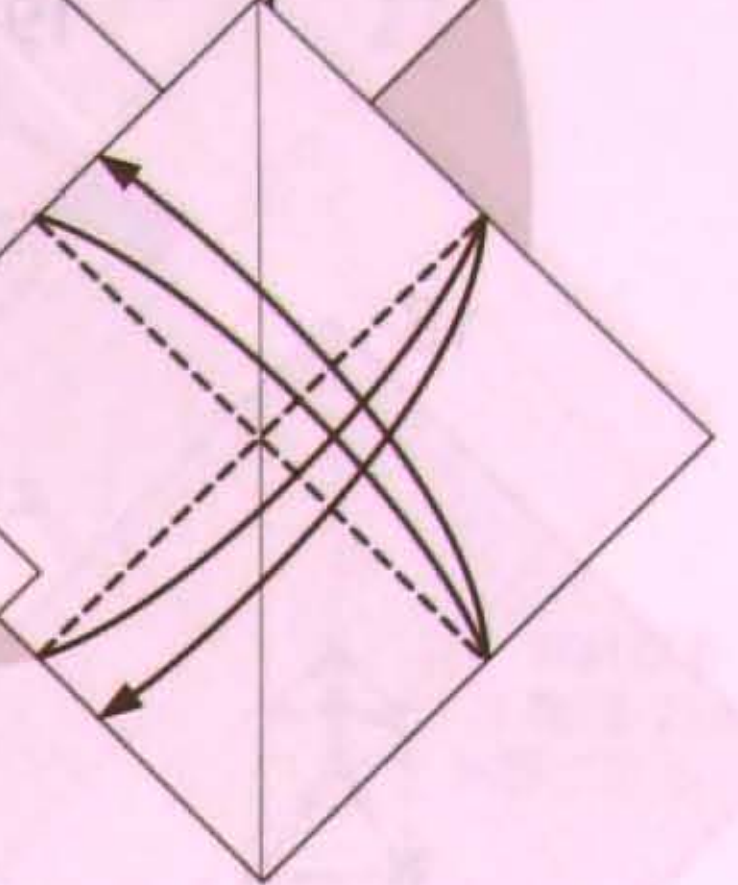

3

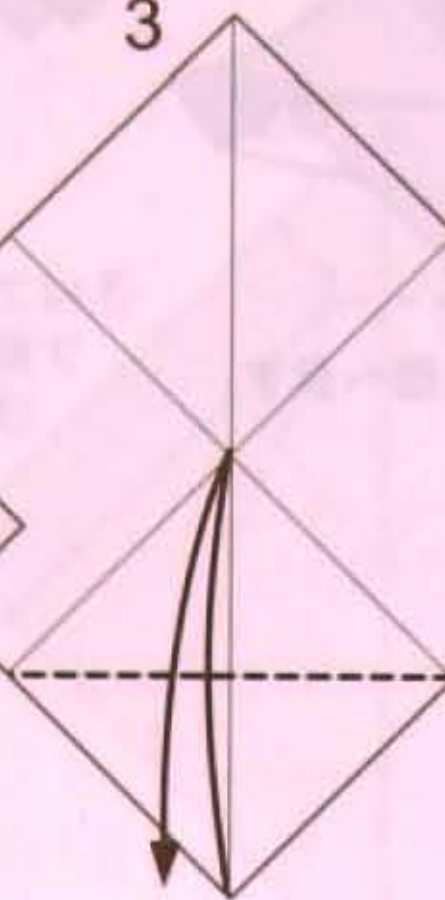

4

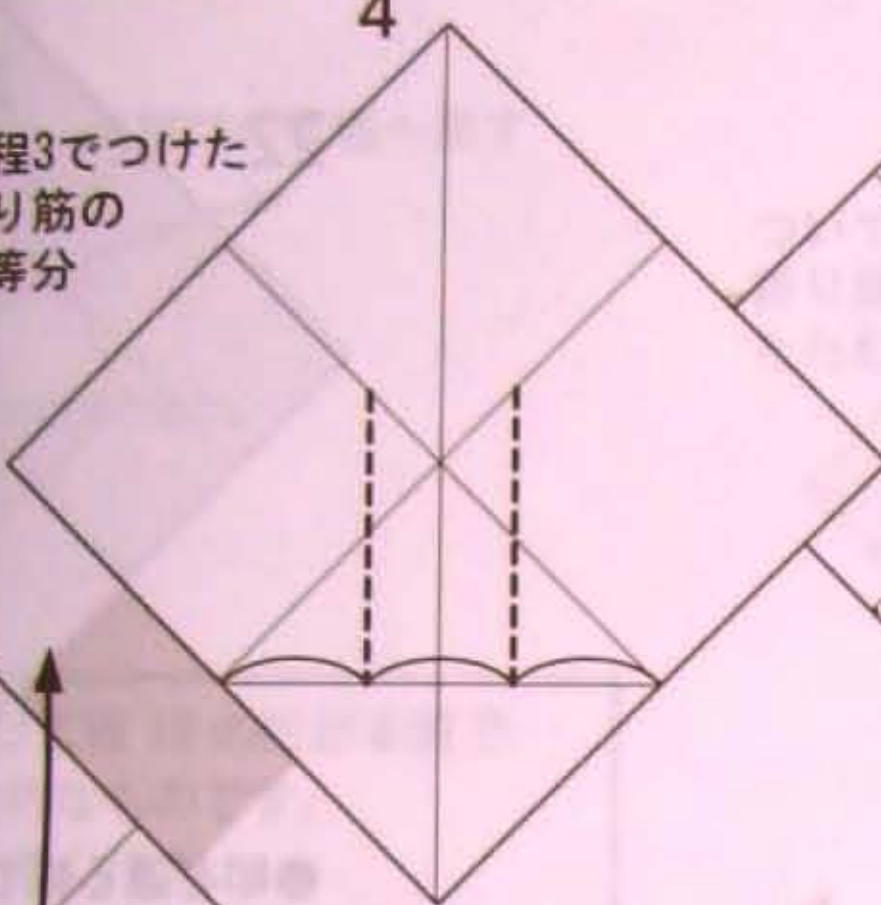

工程3でつけた
折り筋の
三等分

5

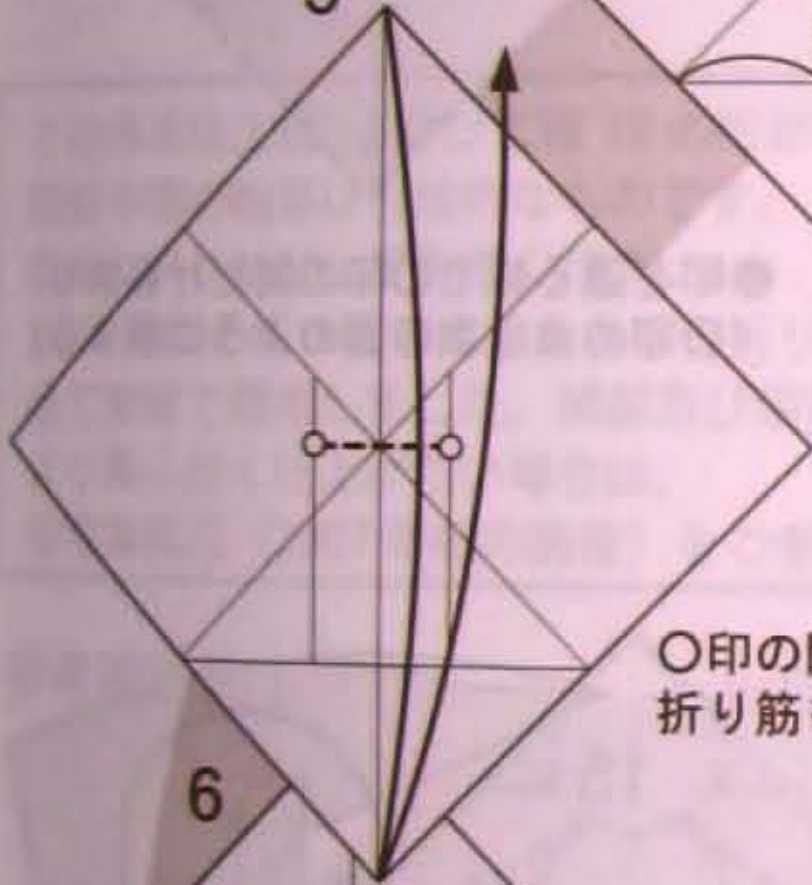

○印の間だけ
折り筋をつける

Japão Burajirujin

www.japaoburajirujin.blogspot.com

10

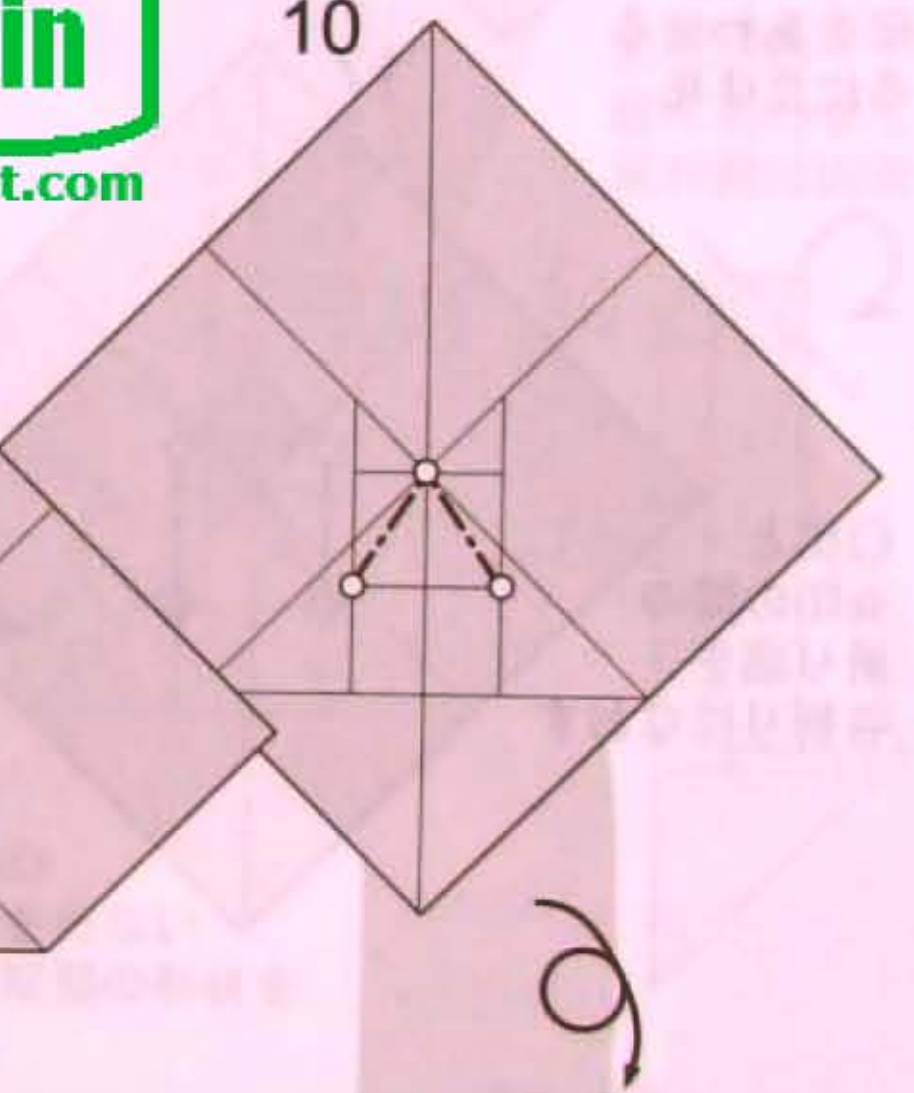

9

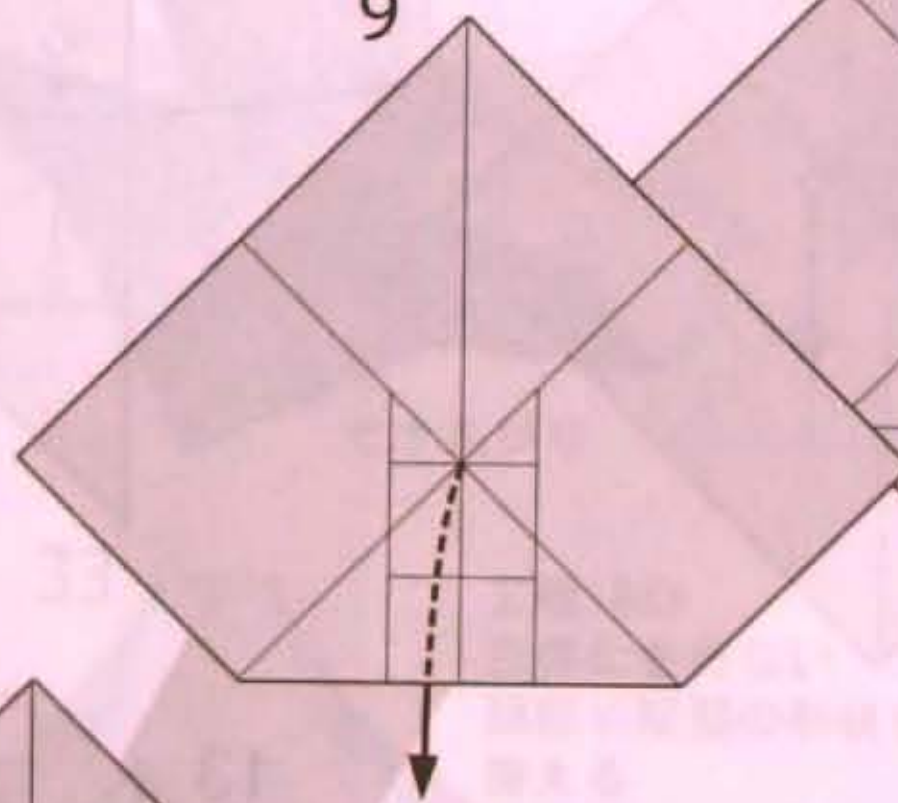

8

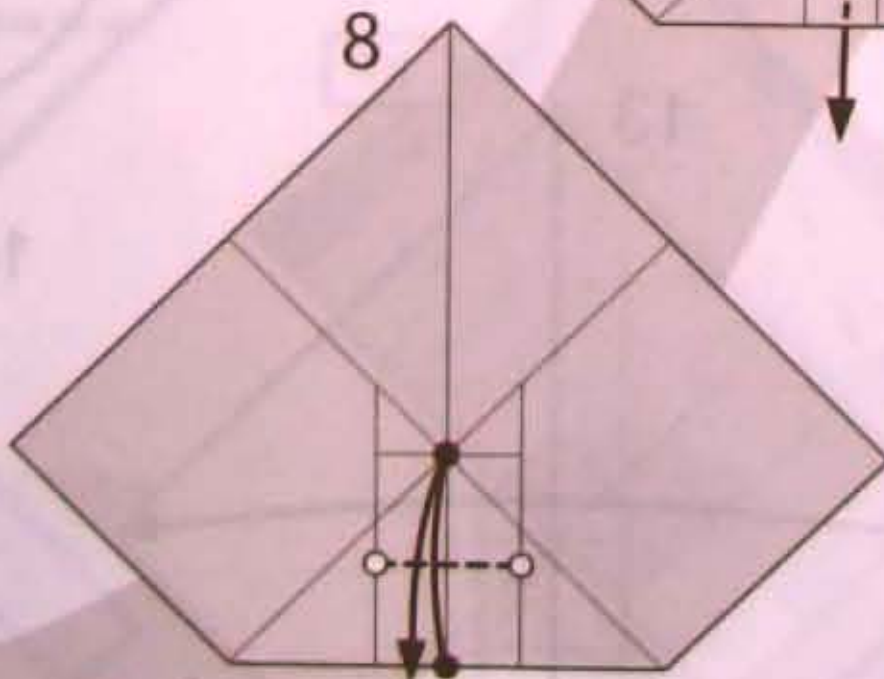

紙の縁を中心に
あわせて○印を
結ぶ折り筋を手前の
層だけにつける

11

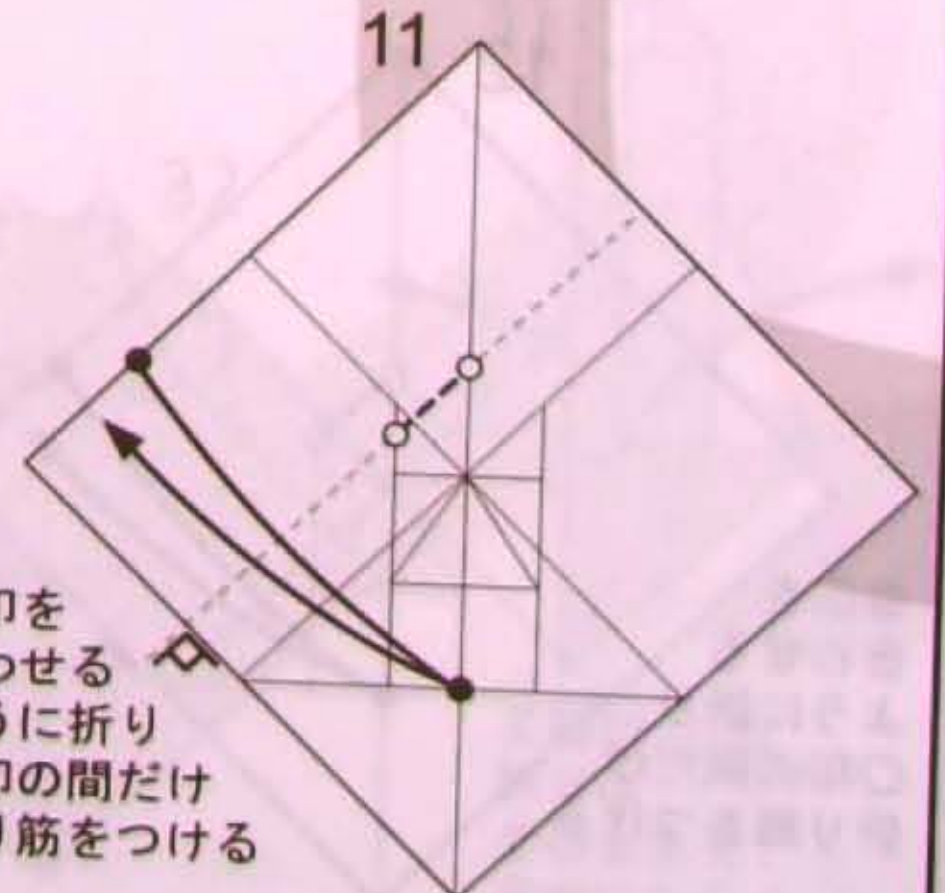

●印を
合わせる
ように折り
○印の間だけ
折り筋をつける

既に
ついている
折り線で折る

7

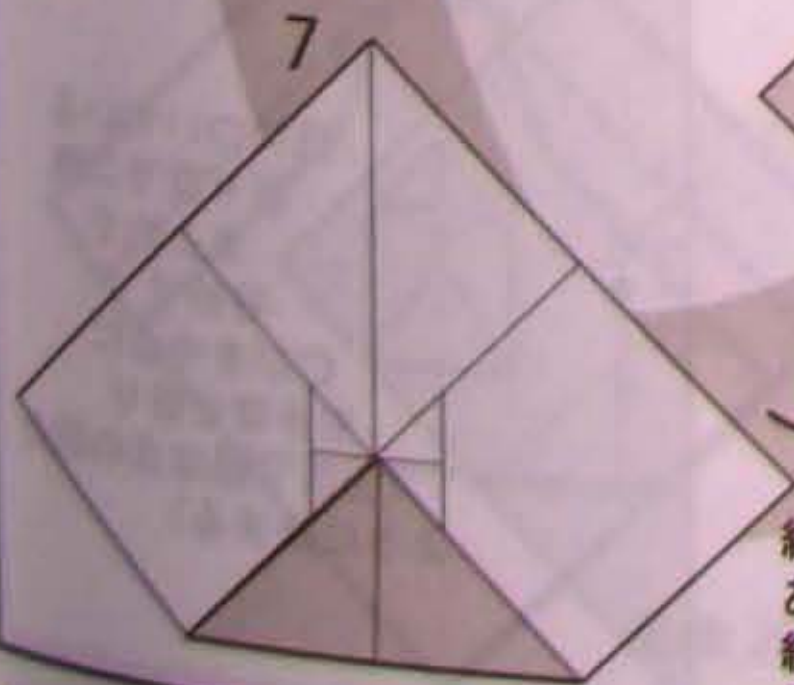

6

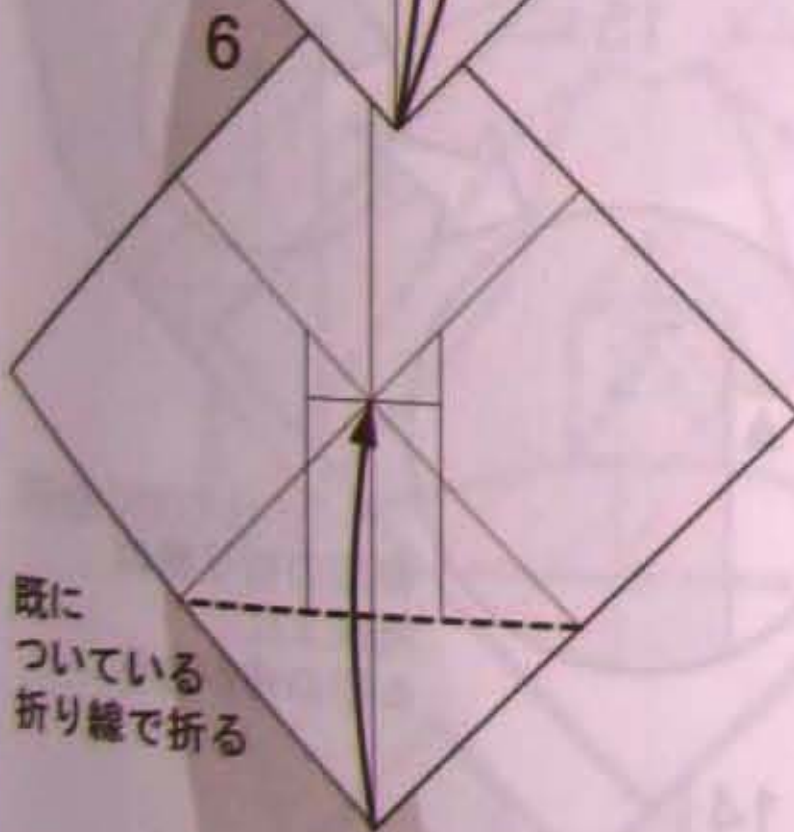

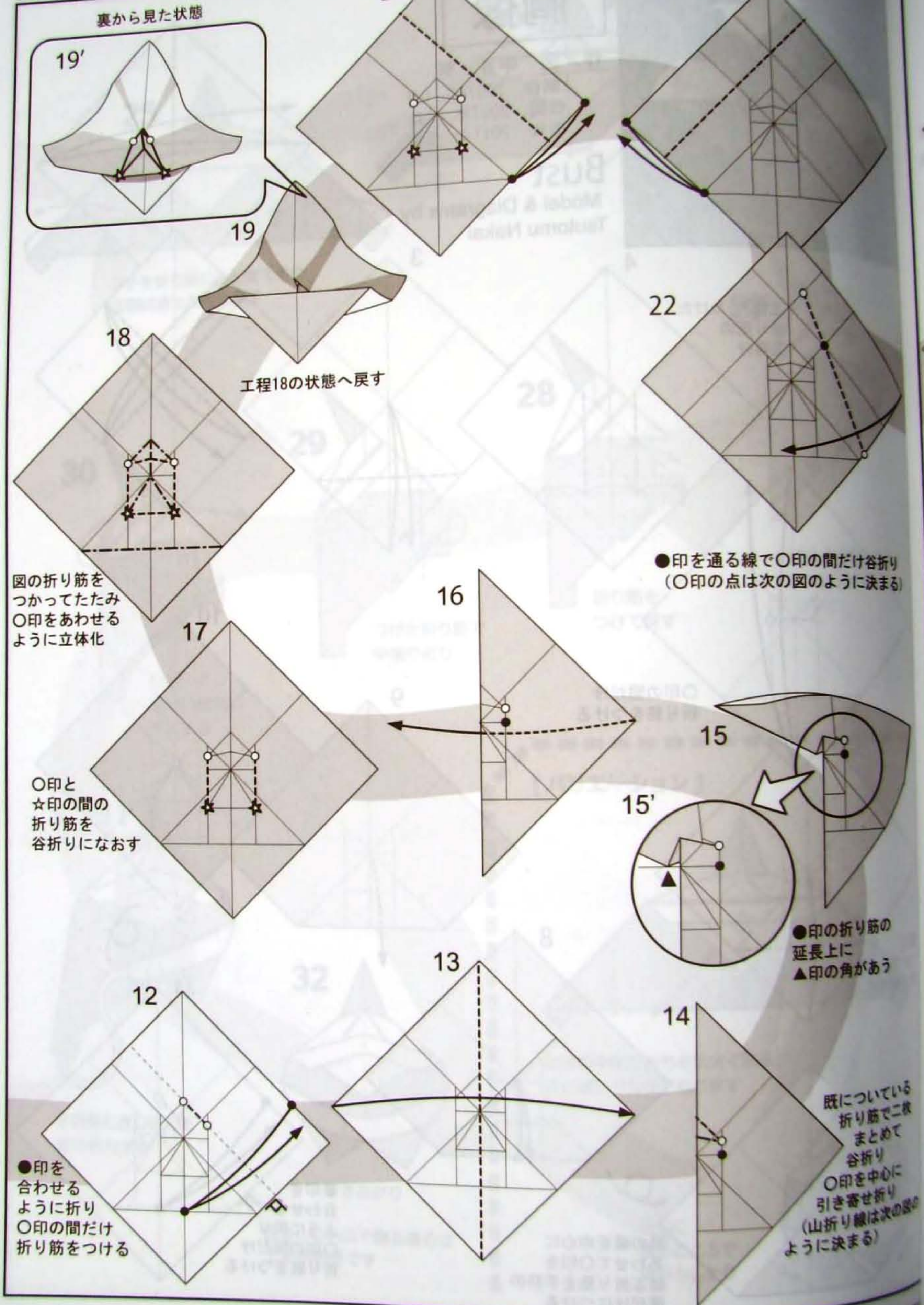

裏から見た状態

19'

19

20

21

18

22

工程18の状態へ戻す

図の折り筋をつかっていたたみ
○印をあわせるように立体化

17

16

●印を通る線で○印の間だけ谷折り
(○印の点は次の図のように決まる)

○印と☆印の間の折り筋を谷折りになおす

15

15'

●印の折り筋の延長上に
▲印の角があう

12

13

14

●印を合わせるように折り
○印の間だけ折り筋をつける

既についている折り筋で二枚まとめて谷折り
○印を中心に引き寄せ折り
(山折り線は次の図のように決まる)

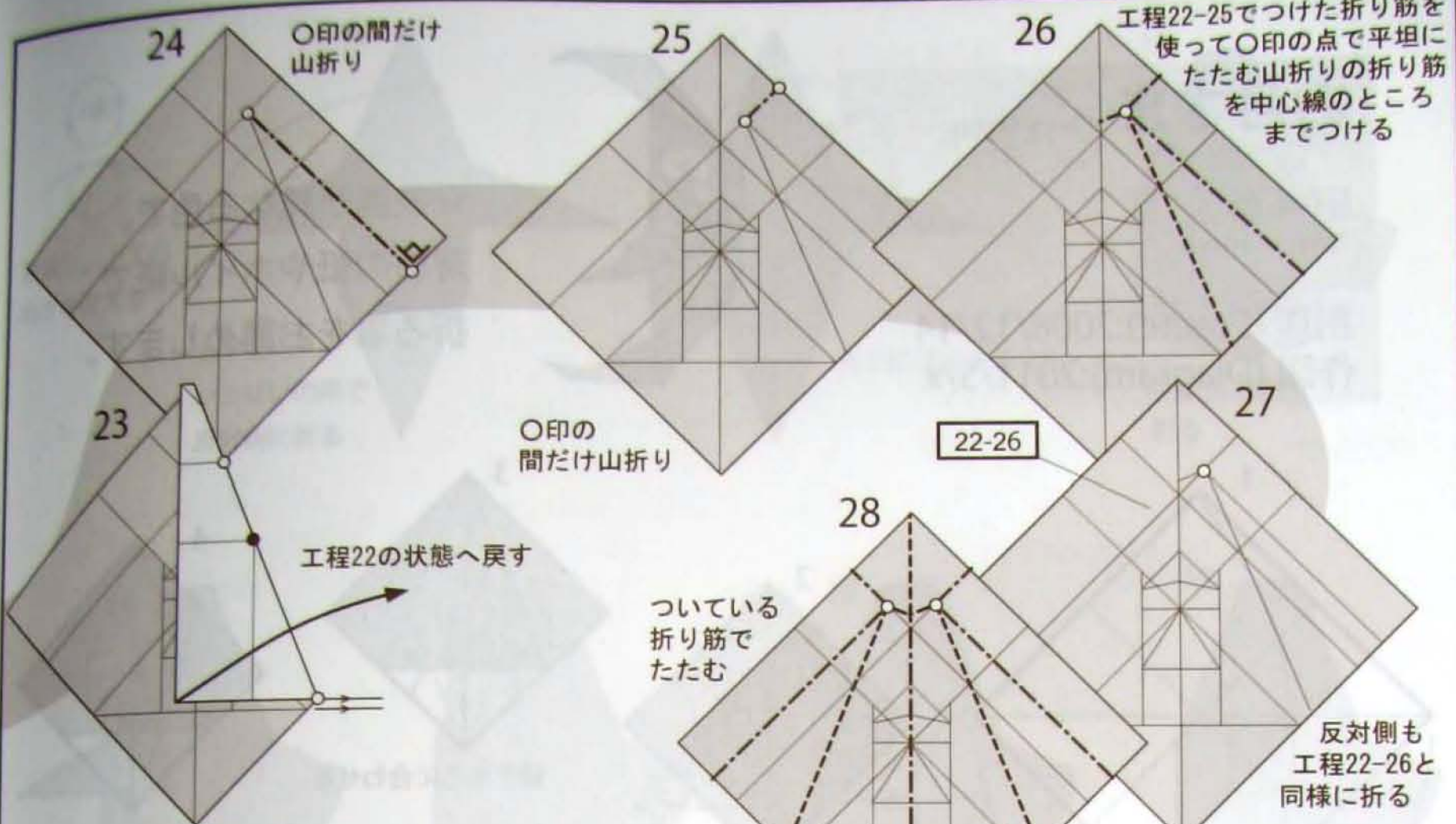

この作品は工程 18 及び工程 19 の形が本質で
 頭髪や顔の輪郭は付加的なものです。
 自由にアレンジしてみてください。
 2011 年版の折り図では基本となる折り筋を
 全て直線で構成しました。頭部及び頭髪の造形を
 より柔らかく仕上げたい場合は、
 参考展開図（2007 年版の胸像）をご参考下さい。

参考展開図：

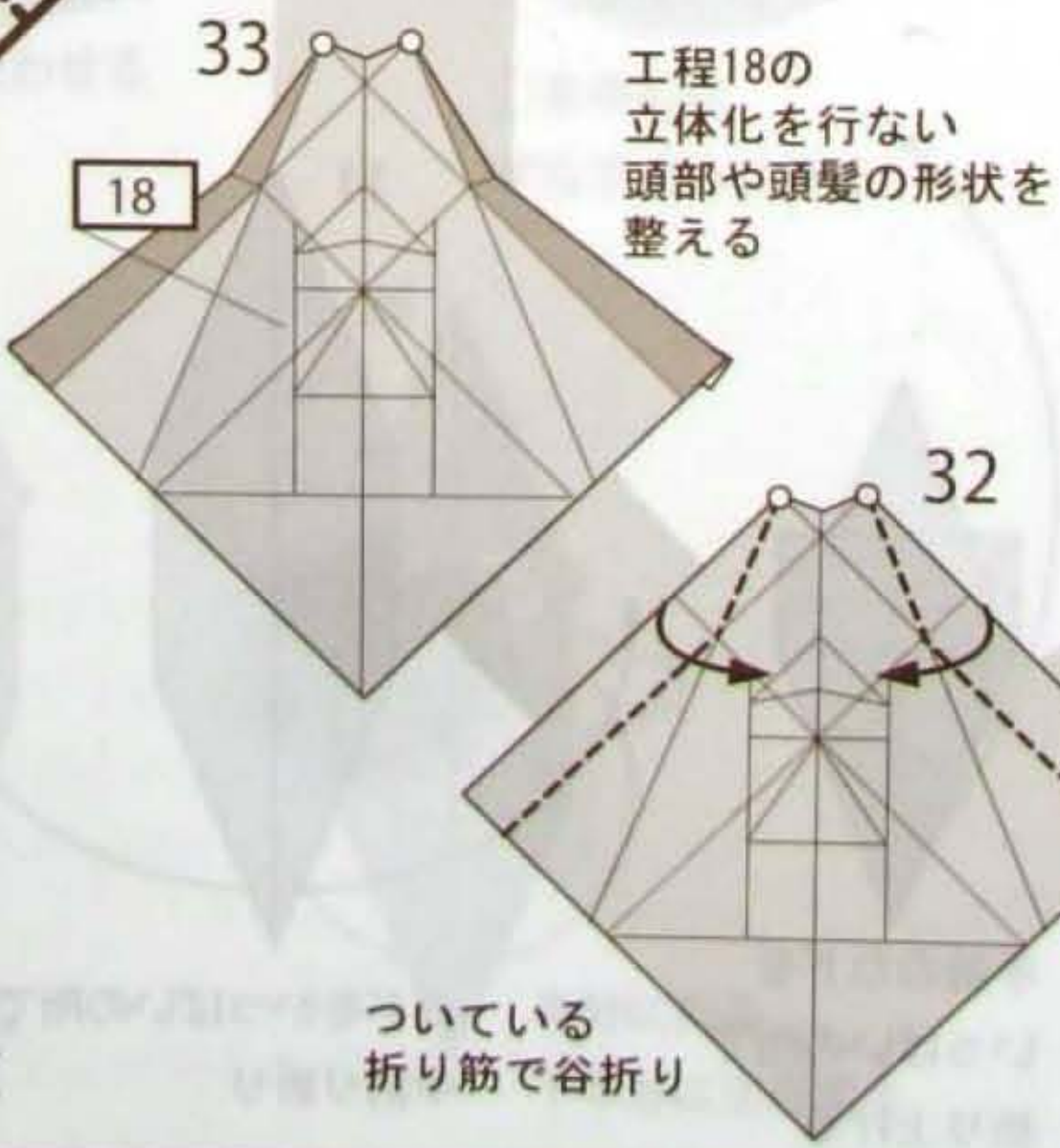
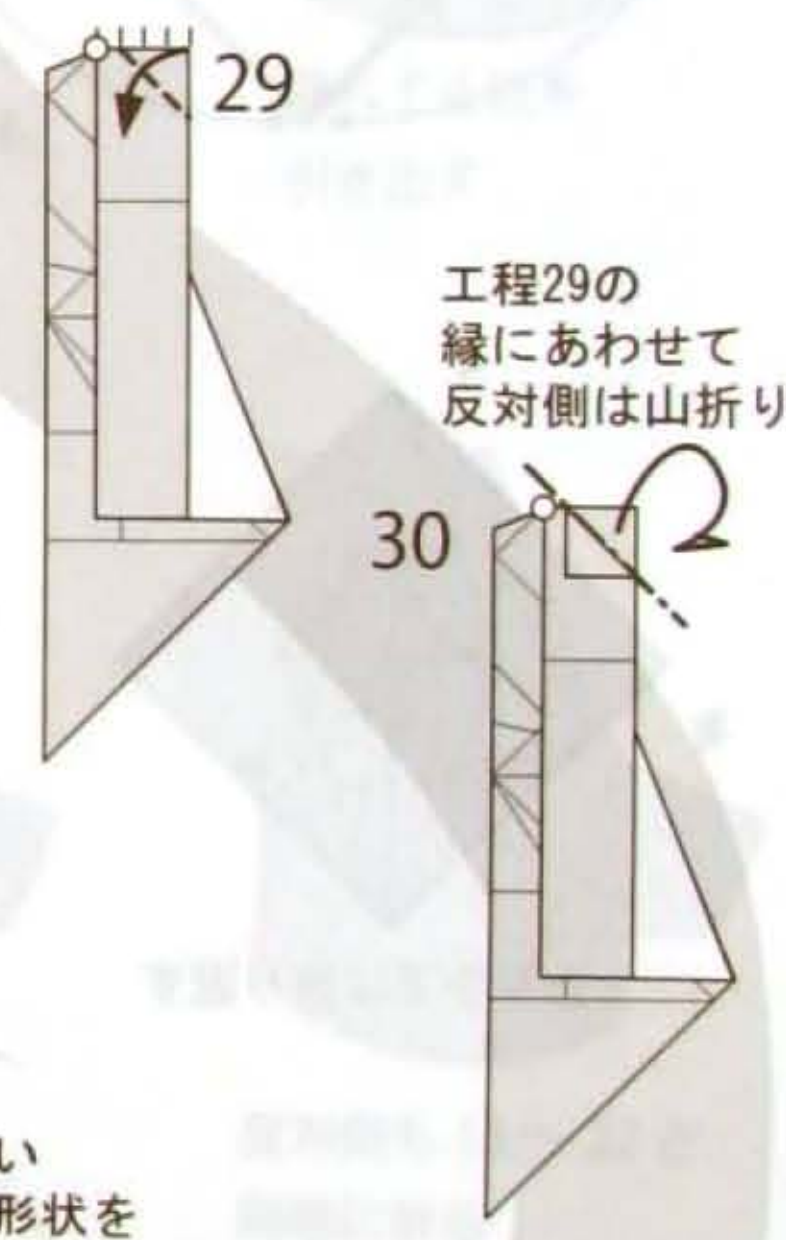
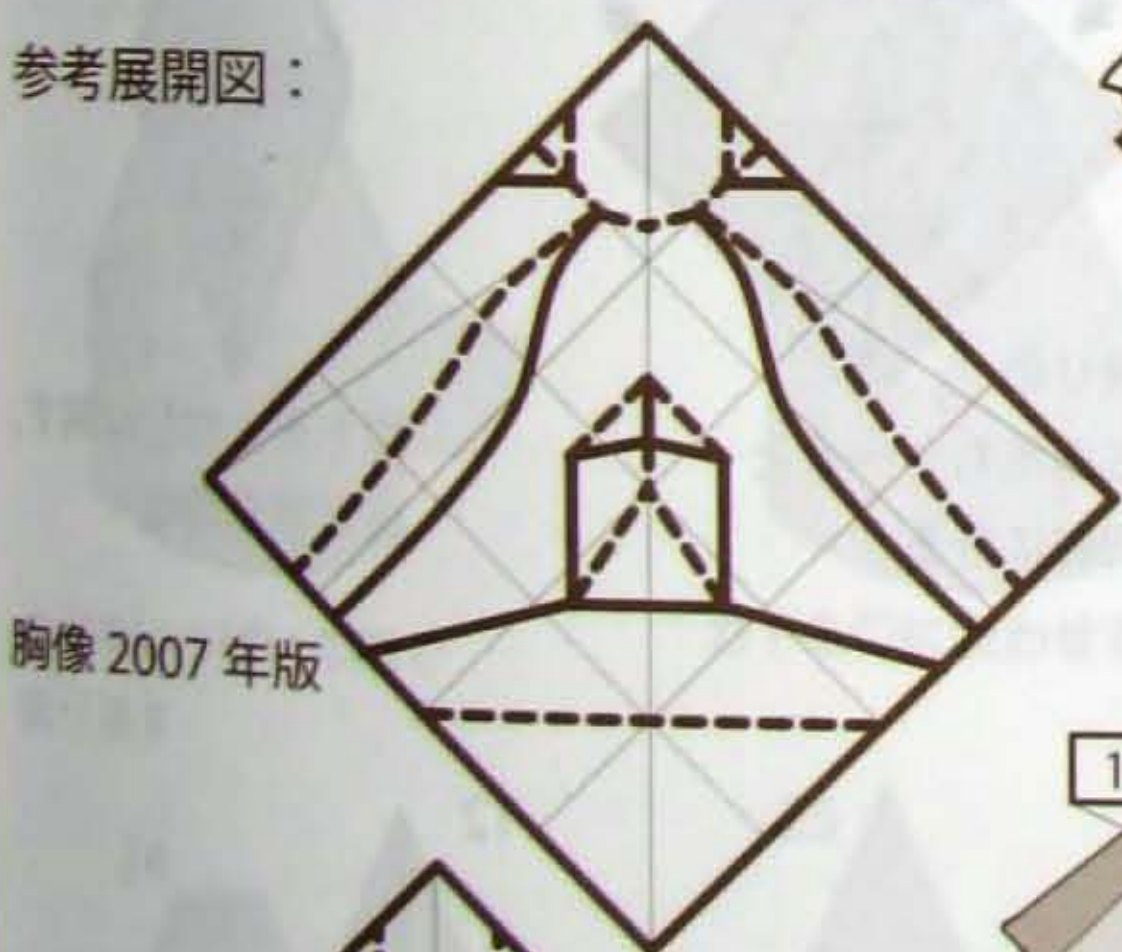

お月さま Fancy Moon

田中 幹人
Mikito Tanaka

創作 (Create): 2008/12/14
作図 (Diagram): 2011/5/x

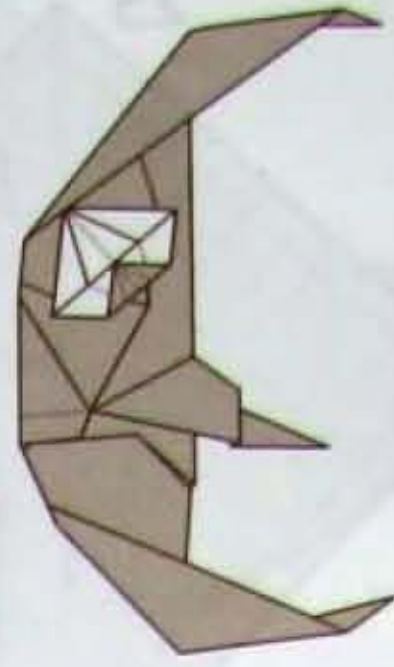

☆表裏が異なる色で、
薄めの紙やホイル紙で
折る事をお薦めします。

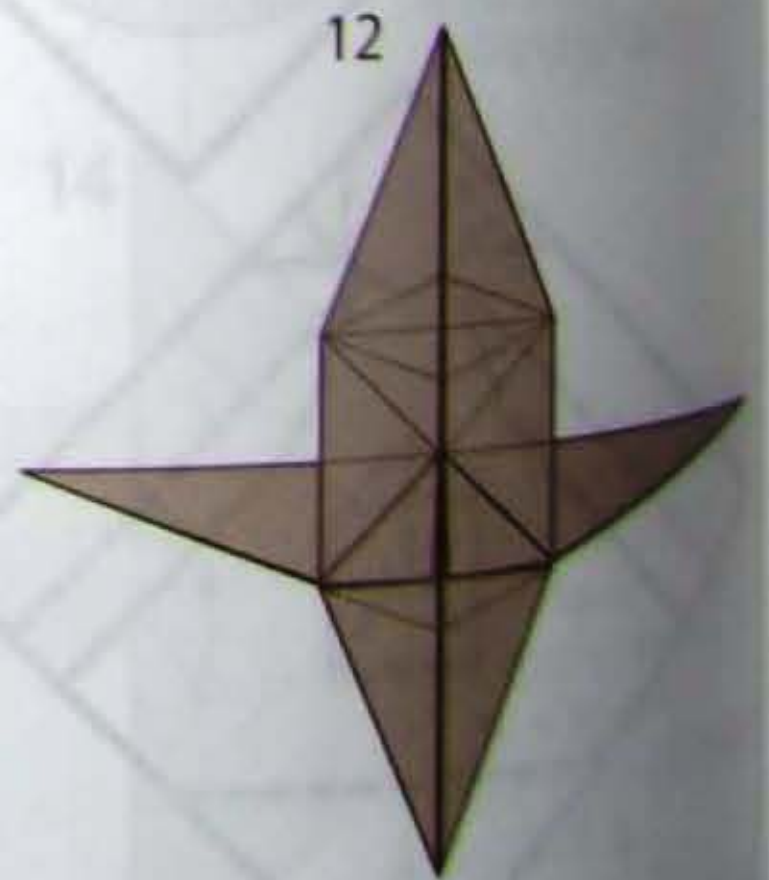
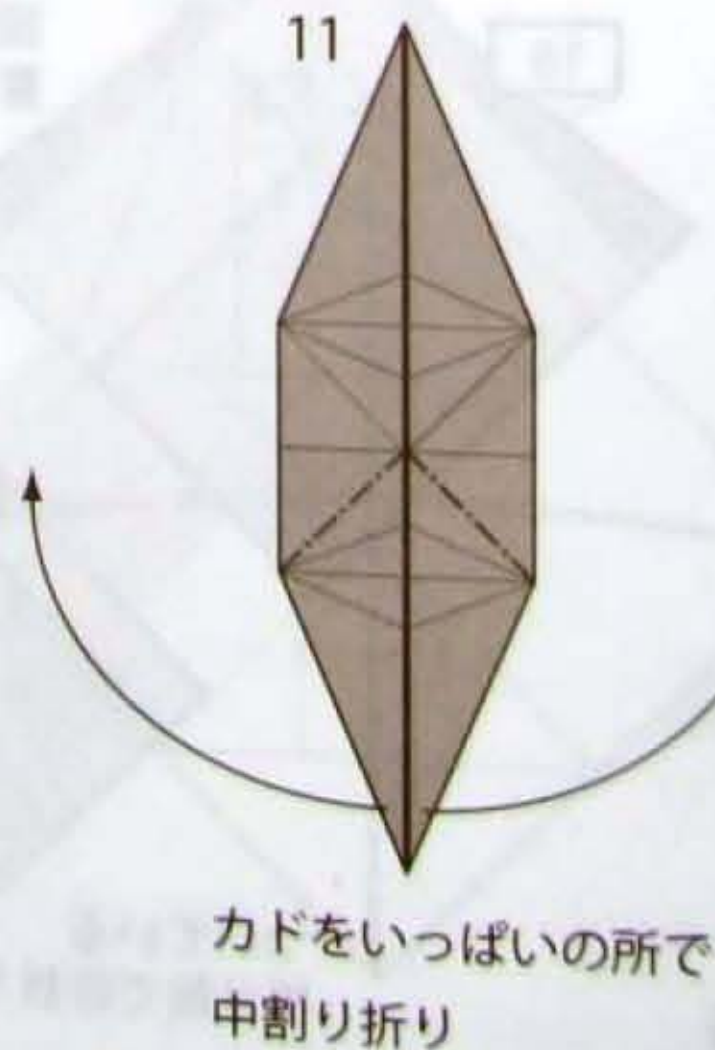
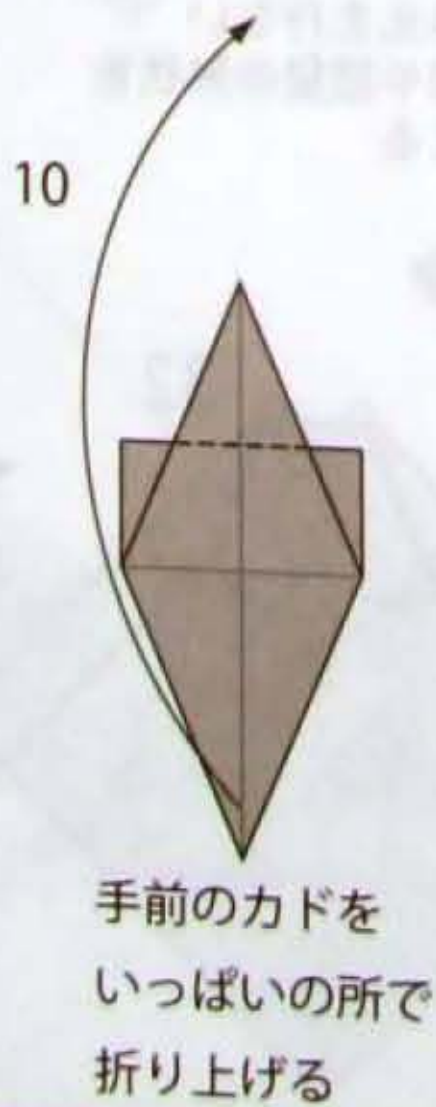
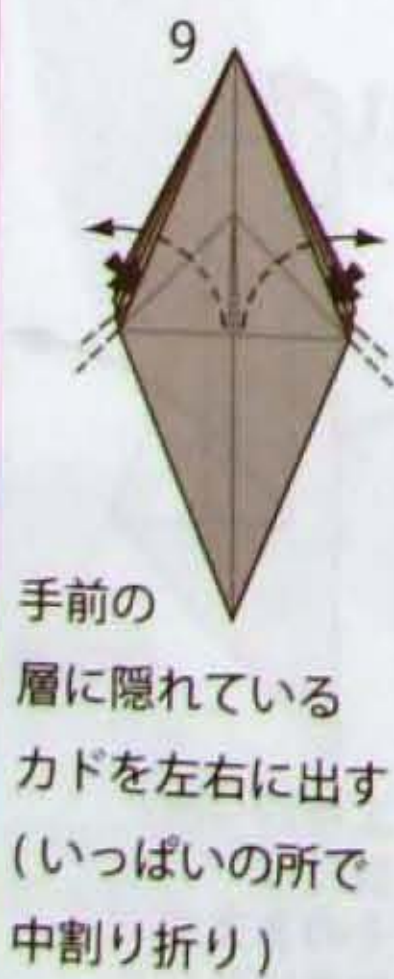
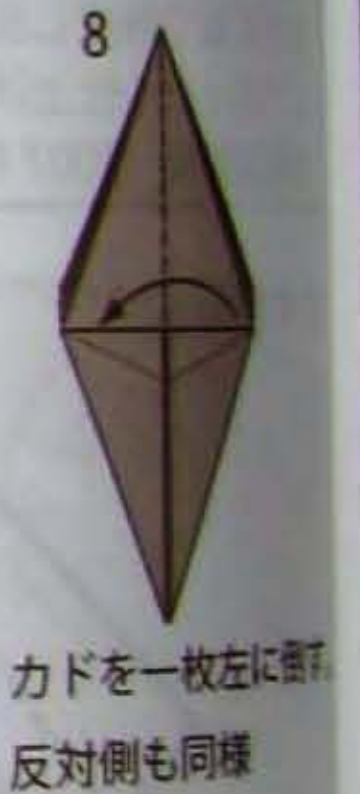
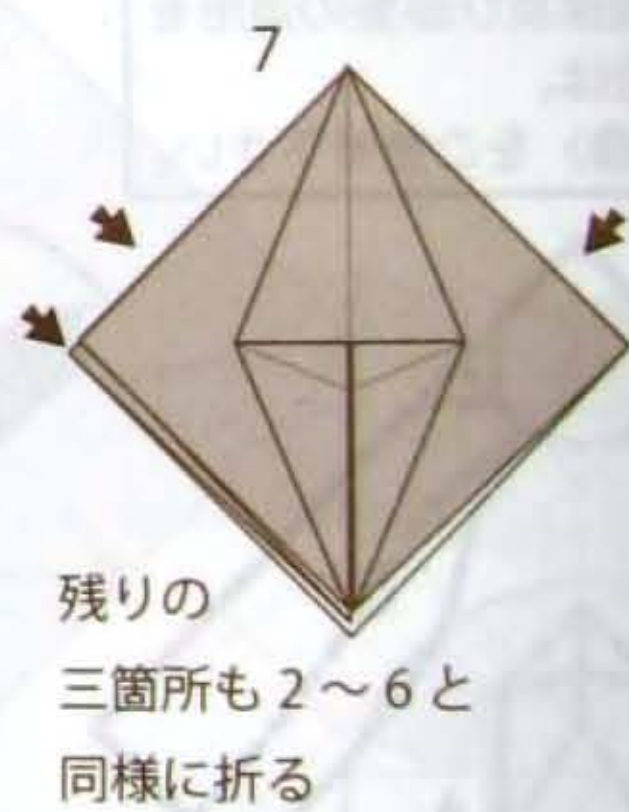
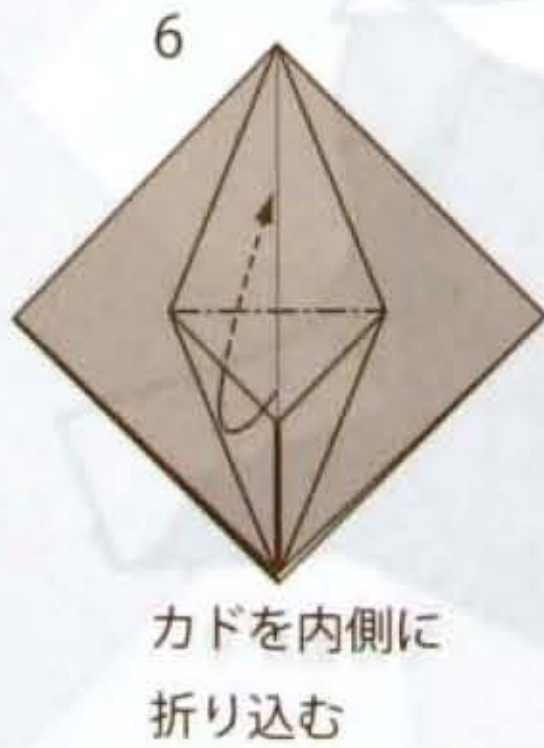
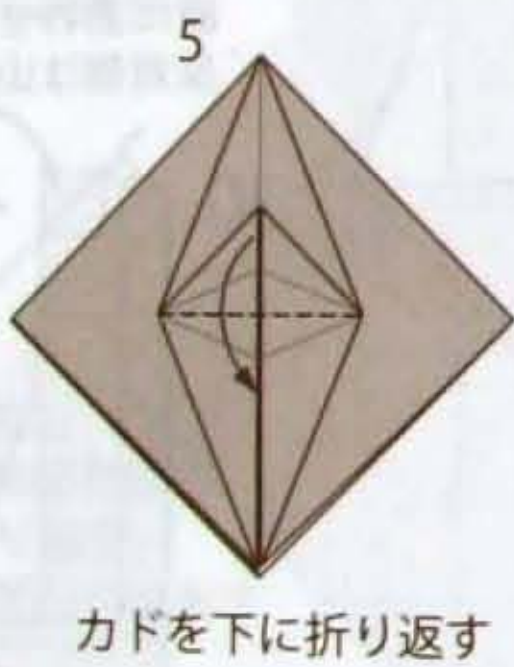
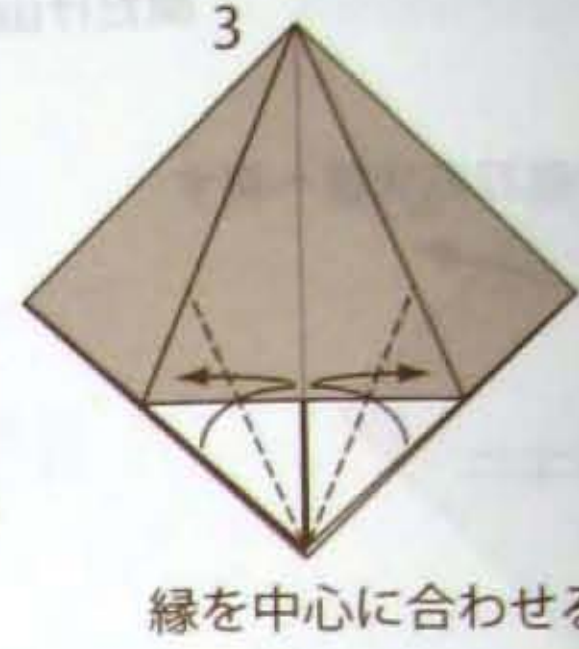
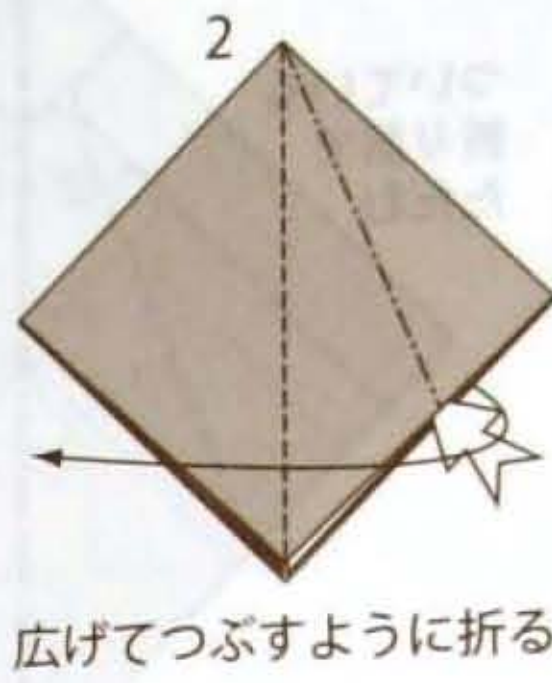
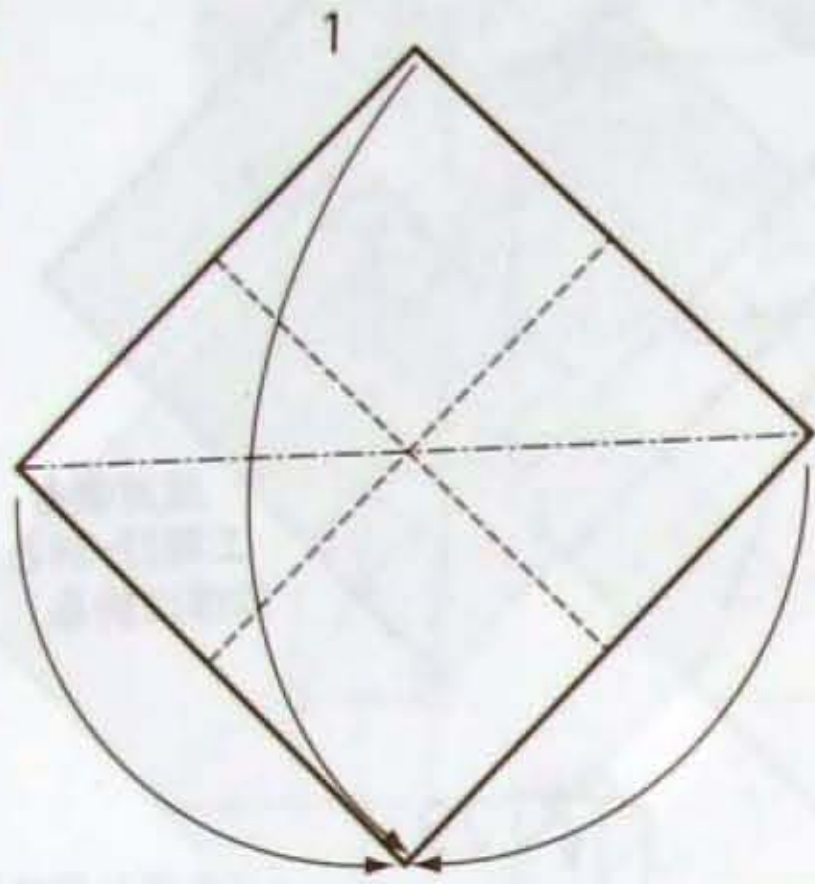

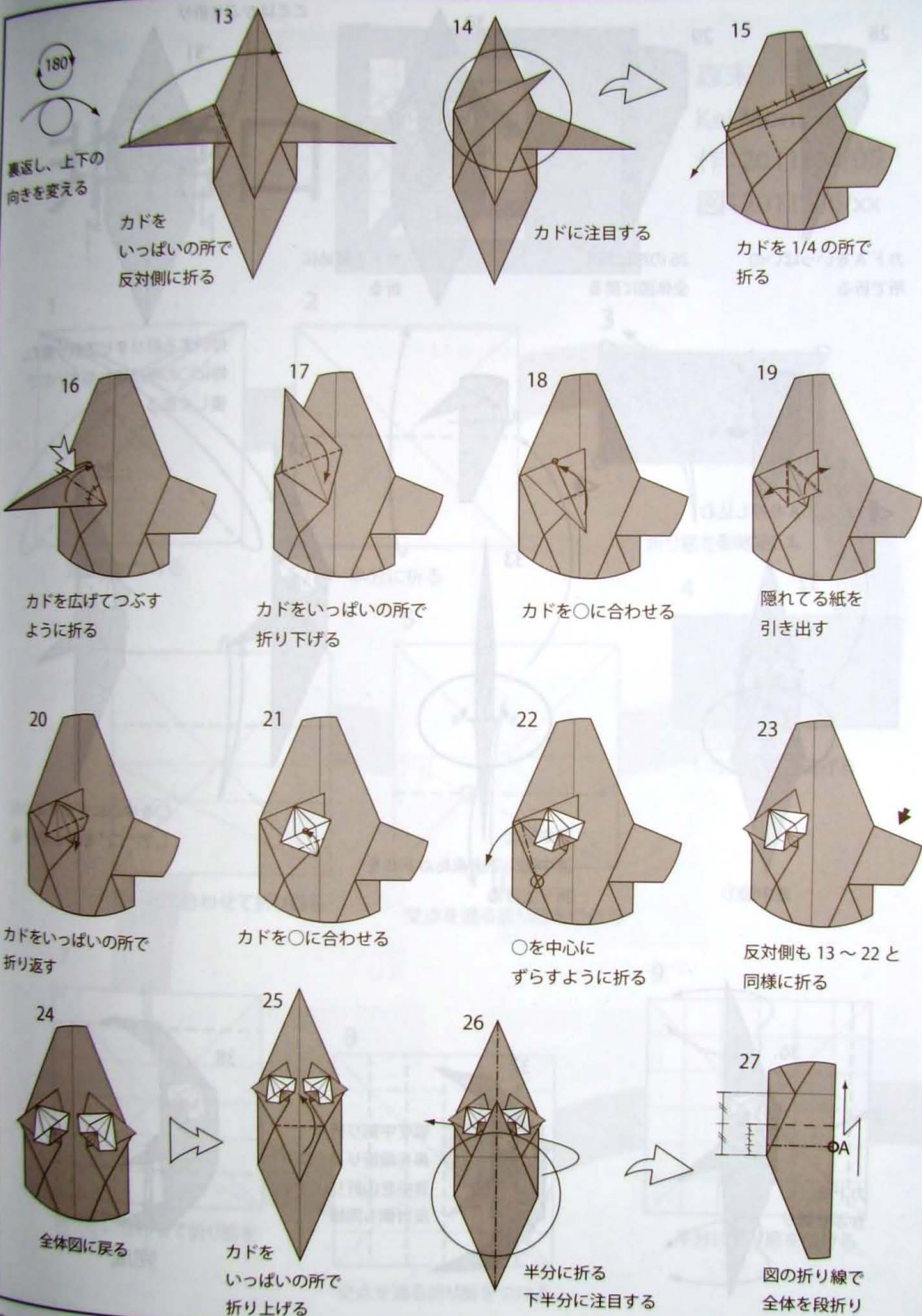

180°
裏返し、上下の向きを変える

カドを
いっぱいので
反対側に折る

カドに注目する

カドを 1/4 の所で
折る

カドを広げてつぶす
ように折る

カドをいっぱいので
折り下げる

カドを○に合わせる

隠れてる紙を
引き出す

カドをいっぱいので
折り返す

カドを○に合わせる

○を中心に
ずらすように折る

反対側も 13 ~ 22 と
同様に折る

全体図に戻る

カドを
いっぱいので
折り上げる

半分に折る
下半分に注目する

図の折り線で
全体を段折り



28 カド A をいっぱい
所で折る

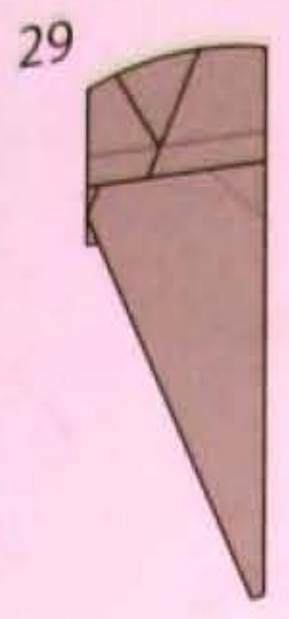

29 26 の形に戻す
全体図に戻る



30 カドを斜めに
折る

ここはかぶせ折り



31 付いてる折りすして折り
特に○の所は破れやすいの
優しく折る

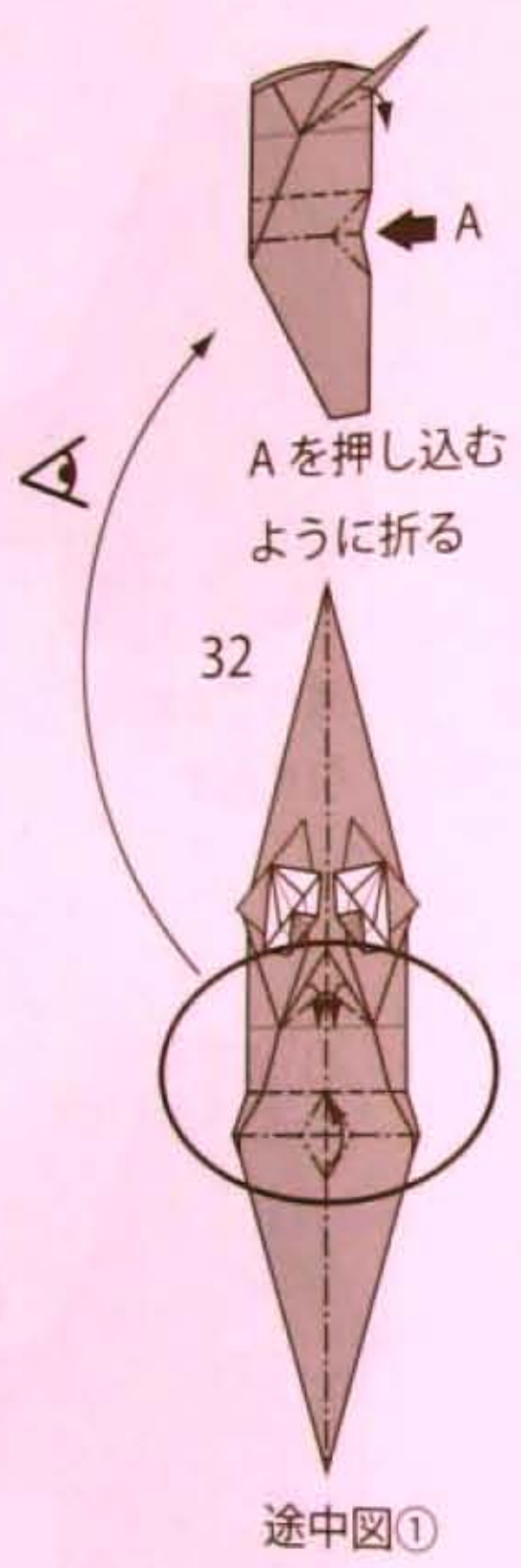

A を押し込む
ように折る

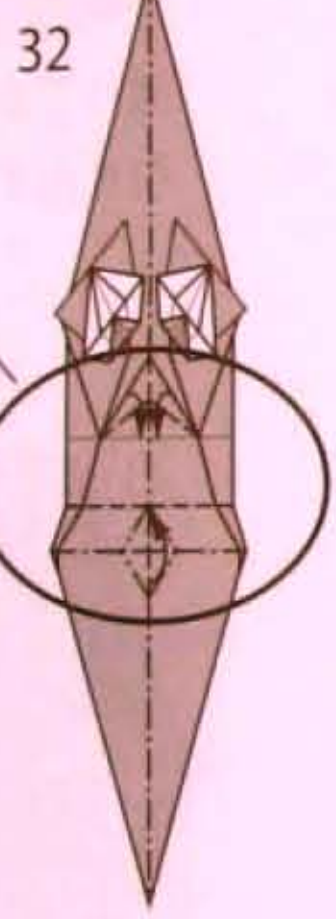

途中図①

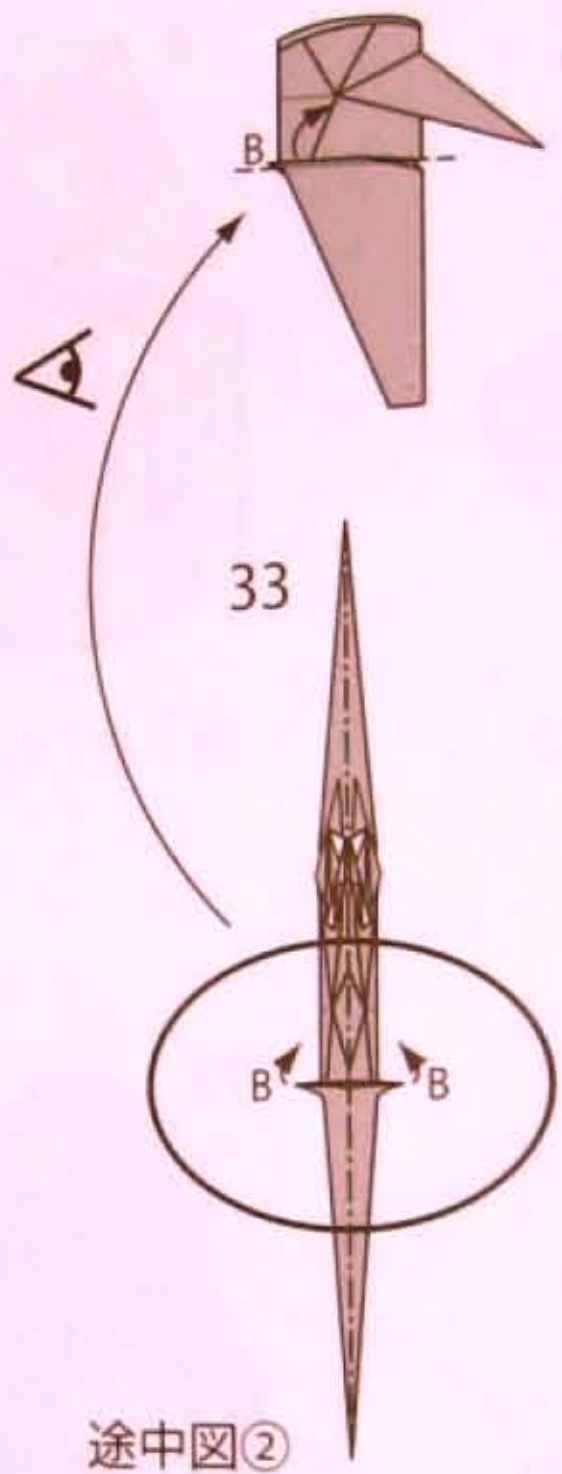

途中図②
途中図①で出来たカド B を
折り上げる

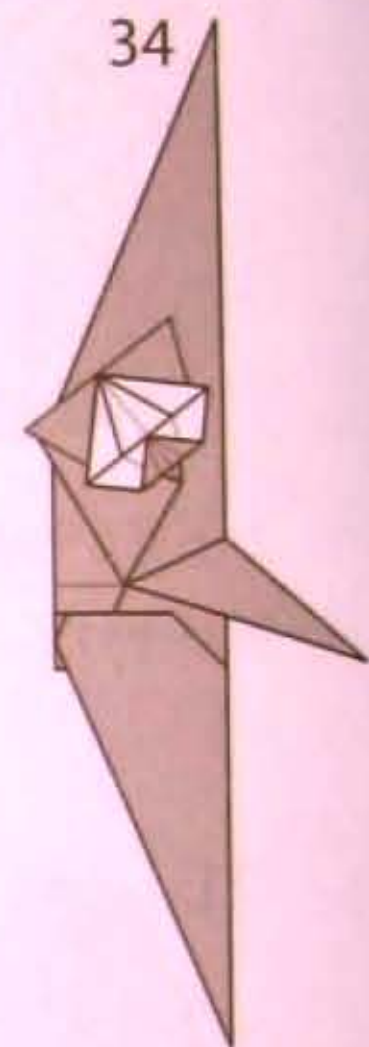

○を中心にずらす
して"口"を少し開

Japão Burajirujin
www.japaoburajirujin.blogspot.com

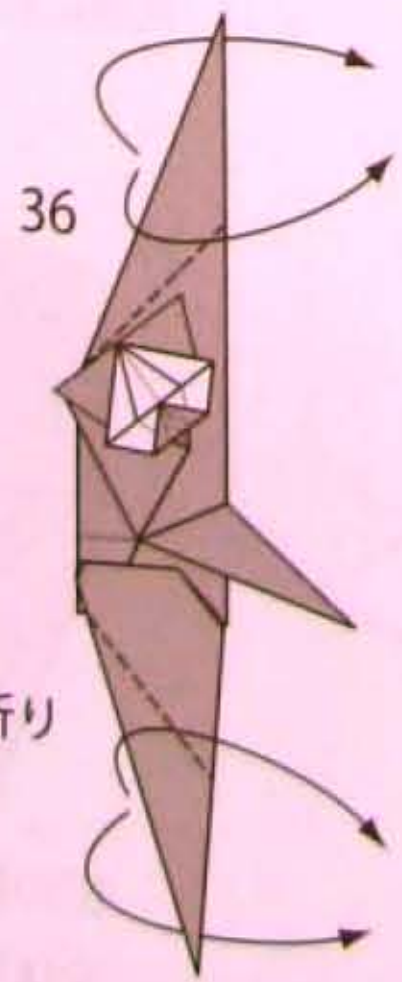

36 カドを
かぶせ折り

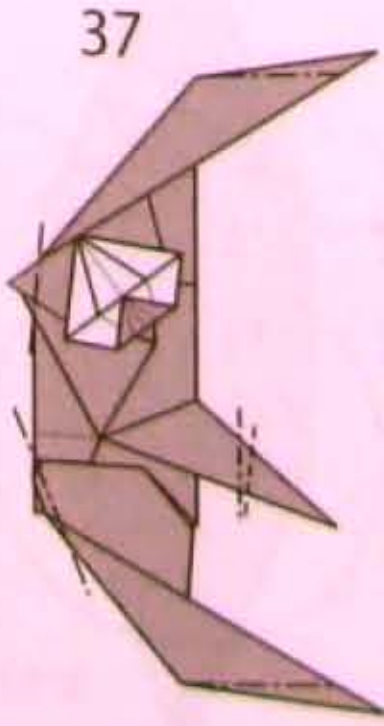

37 弧を中割り折り
鼻を段折り
背中を山折り。
反対側も同様

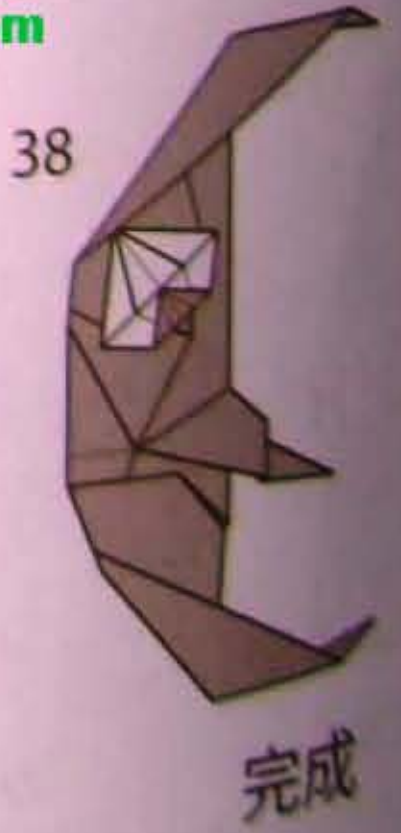

38 完成

非常口

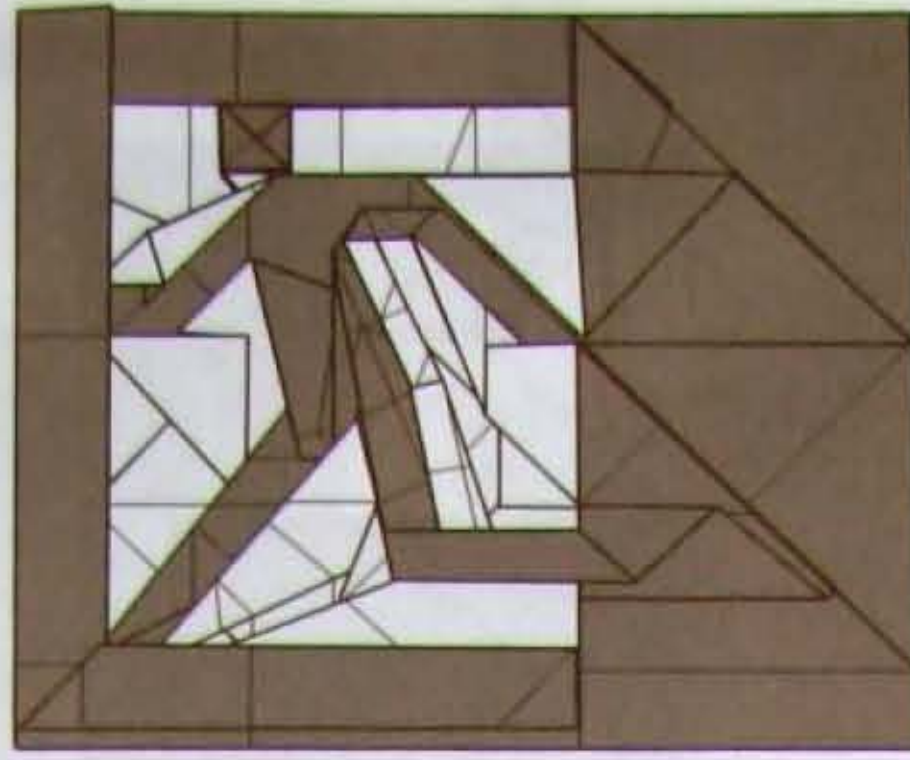

森末 圭

Kei Morisue

作:2011/04/05

図:2011/06/xx

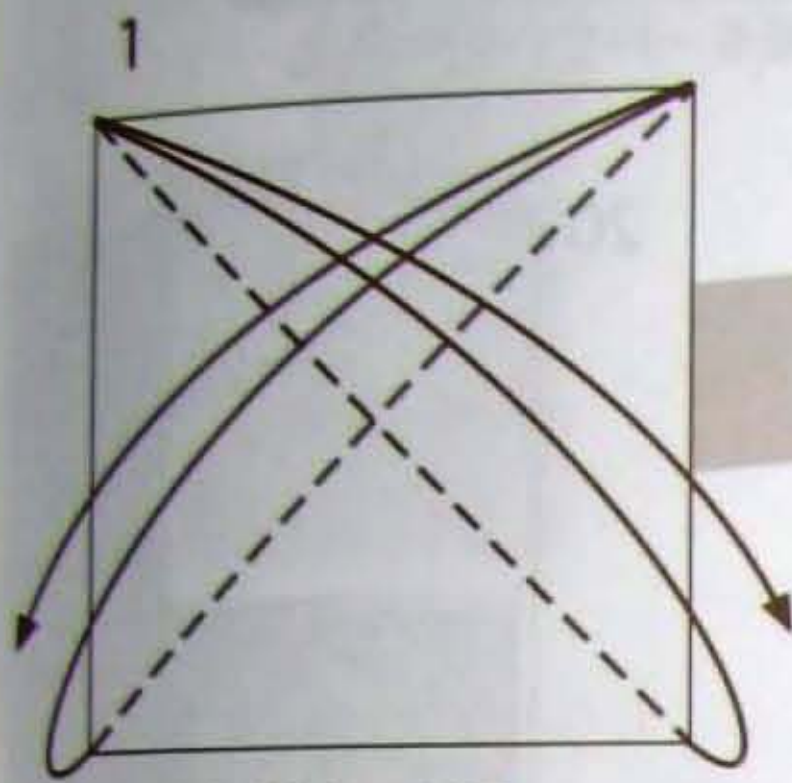

折り筋をつける

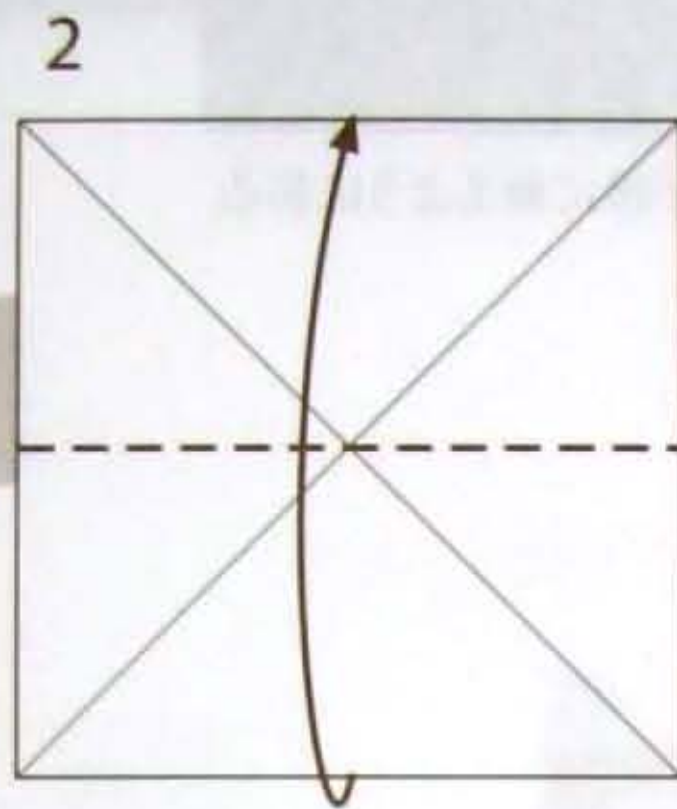

半分に折る

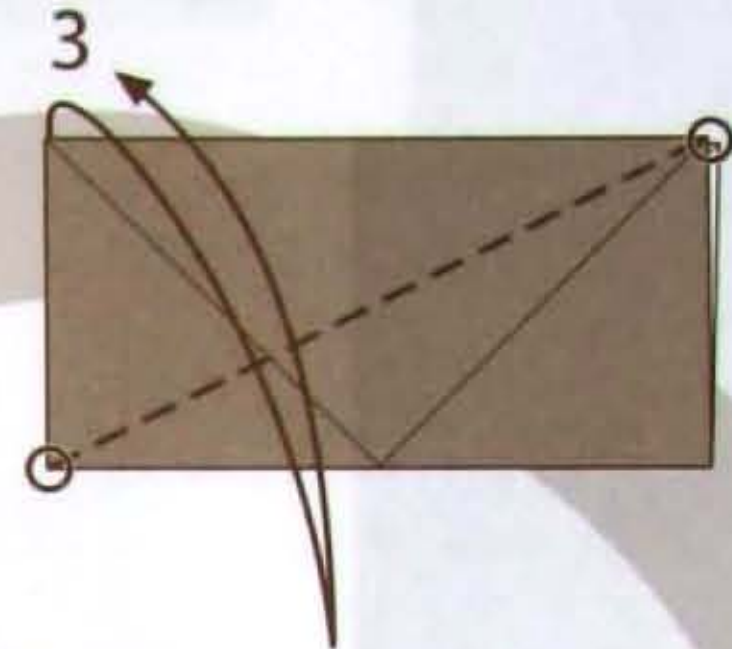

折り筋をつける



1の状態まで広げる

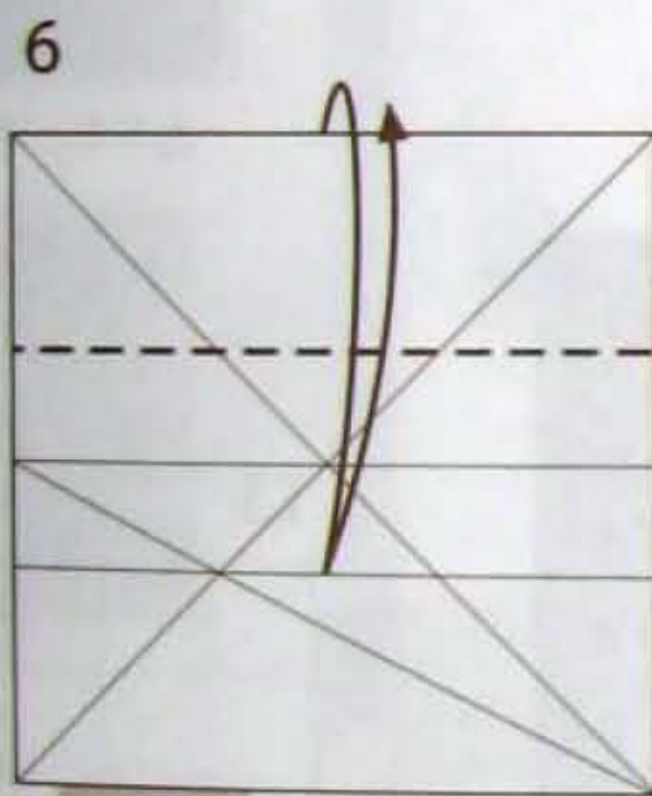

折り筋に合わせて折り筋をつける

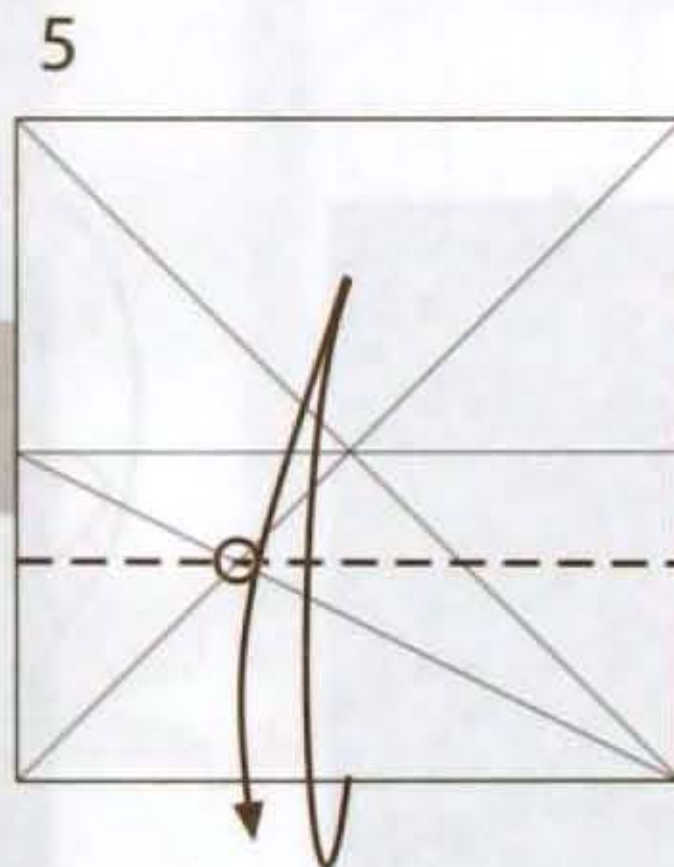

交点を通る折り筋をつける

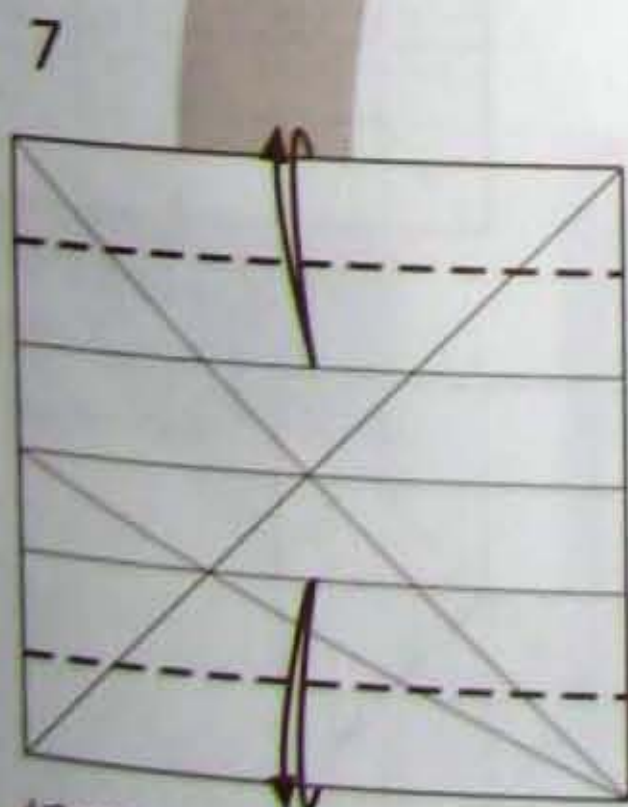

折り筋に合わせて折り筋をつける

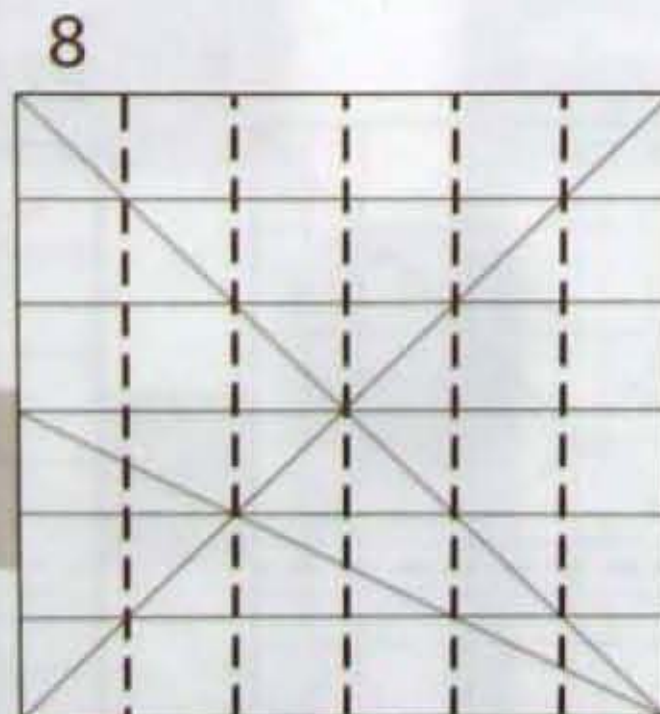

交点を通る折り筋をつける

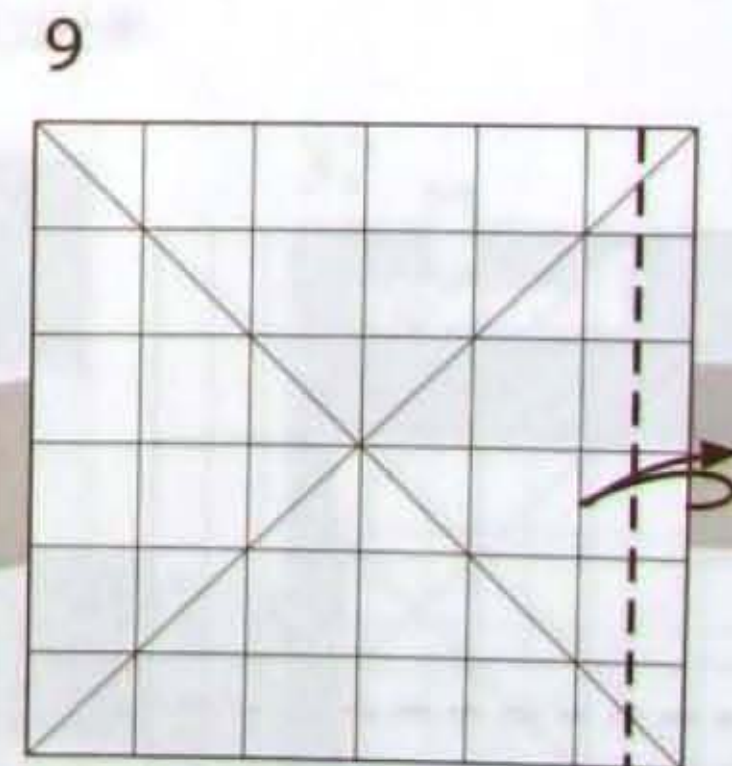

半分に折り筋をつける

に
る

17

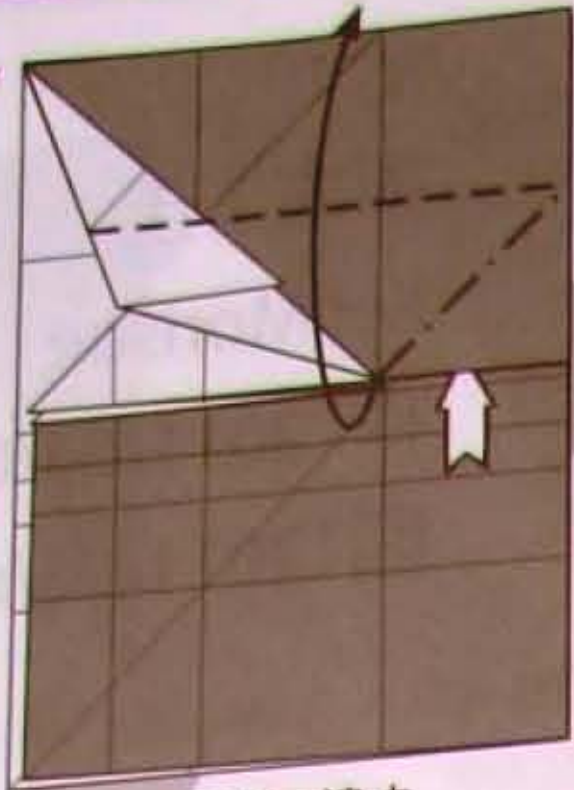

ひろげて潰す

18

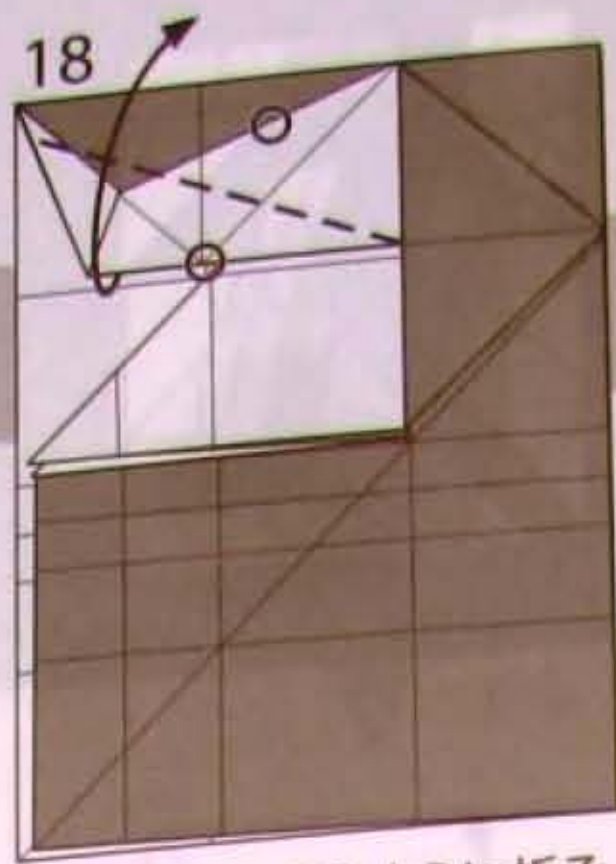

交点が縁に乗るように折る

19



紙を一杯まで引き寄せる

16

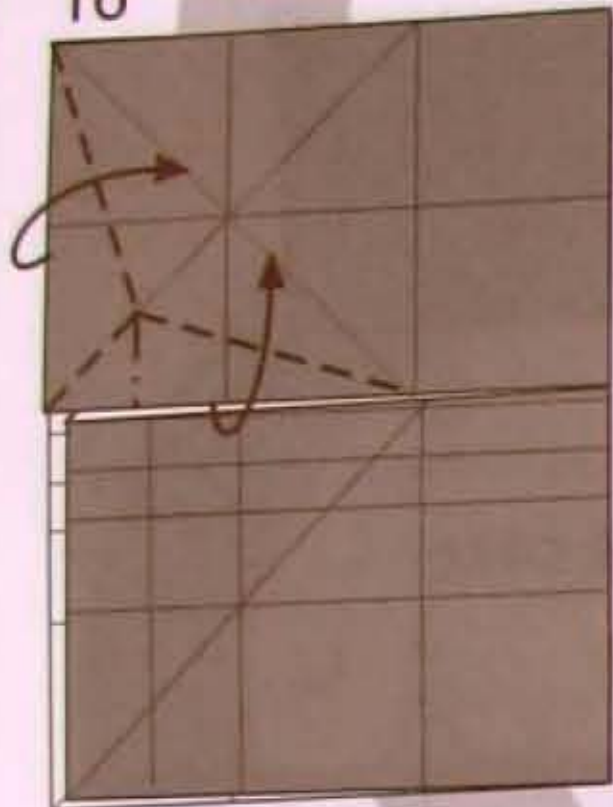

半分につまみ折り

Japão Burajirujin

www.japaoburajirujin.blogspot.com

20



カドを一杯のところで折る

15

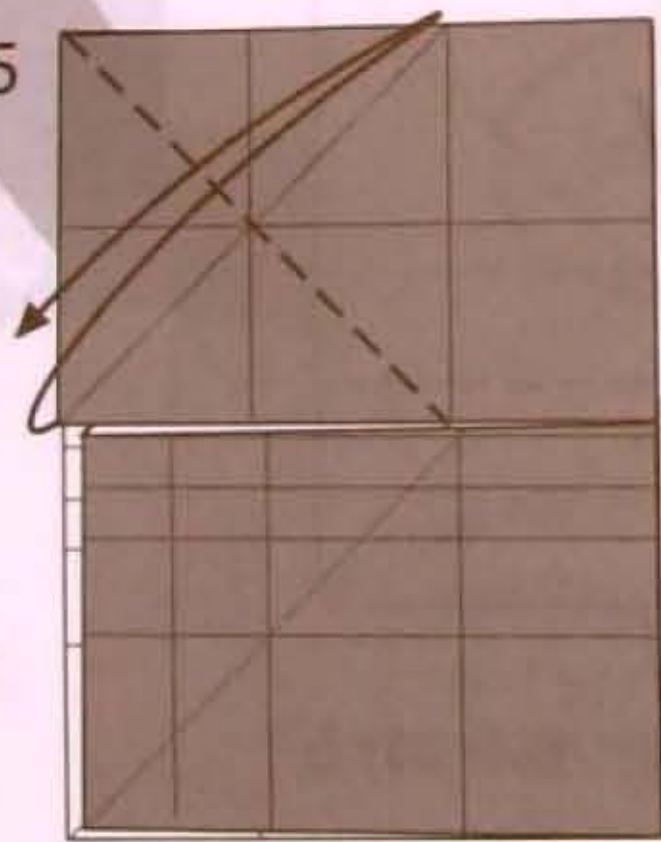

半分に折り筋をつける

14

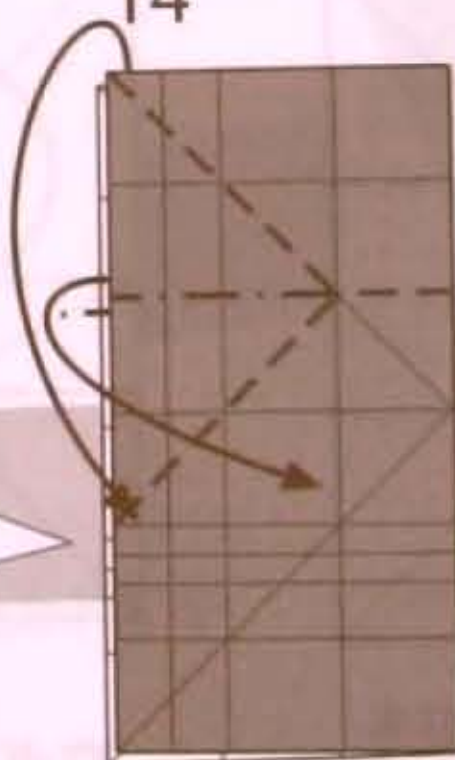

上の一枚を折り筋に合わせて畳む

13

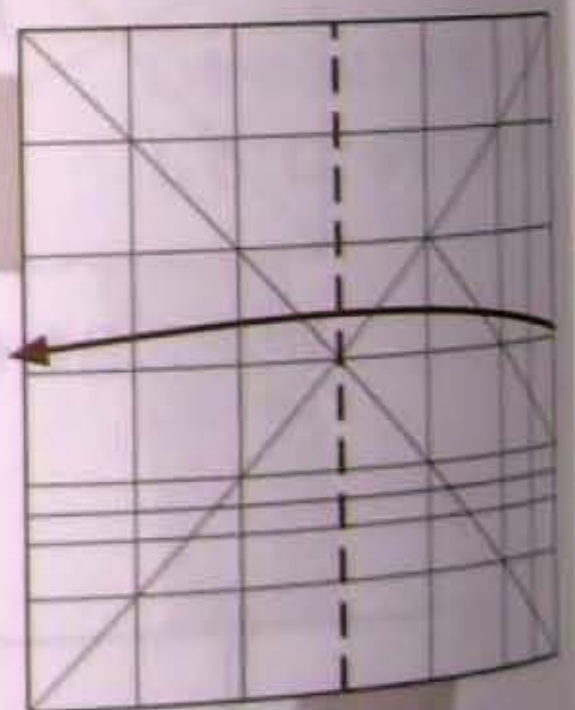

半分に折る

10

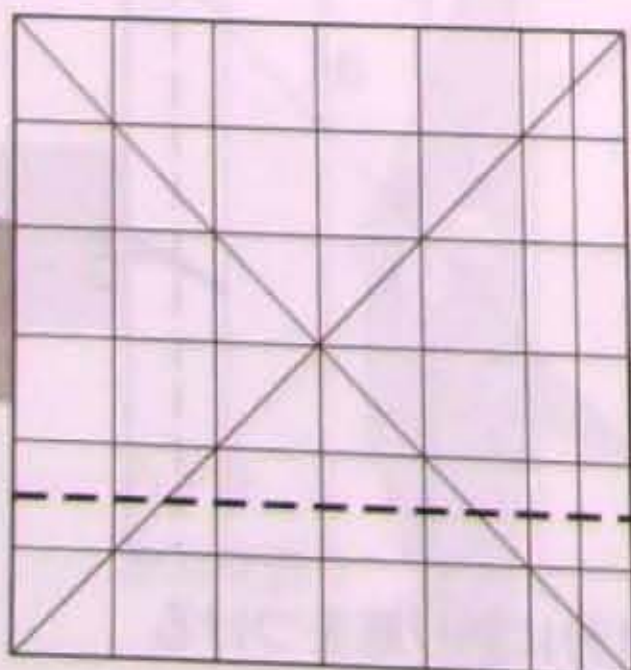

半分に折り筋をつける

11

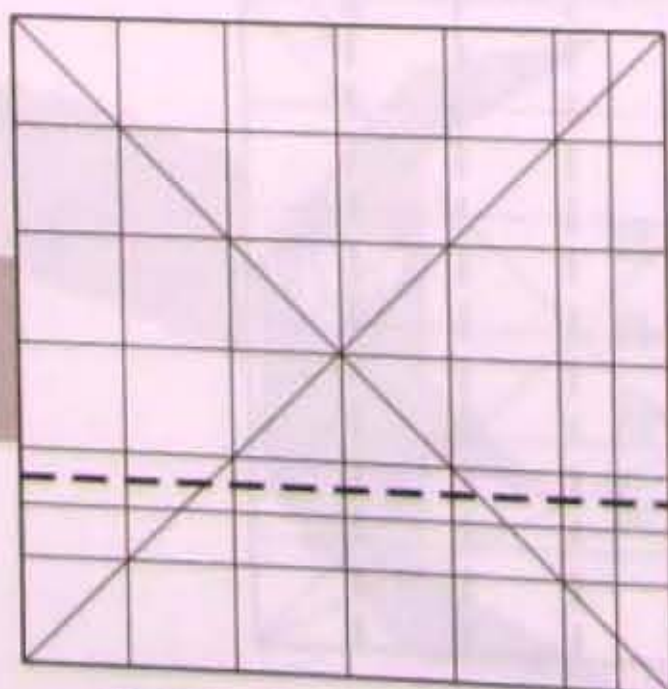

半分に折り筋をつける

12

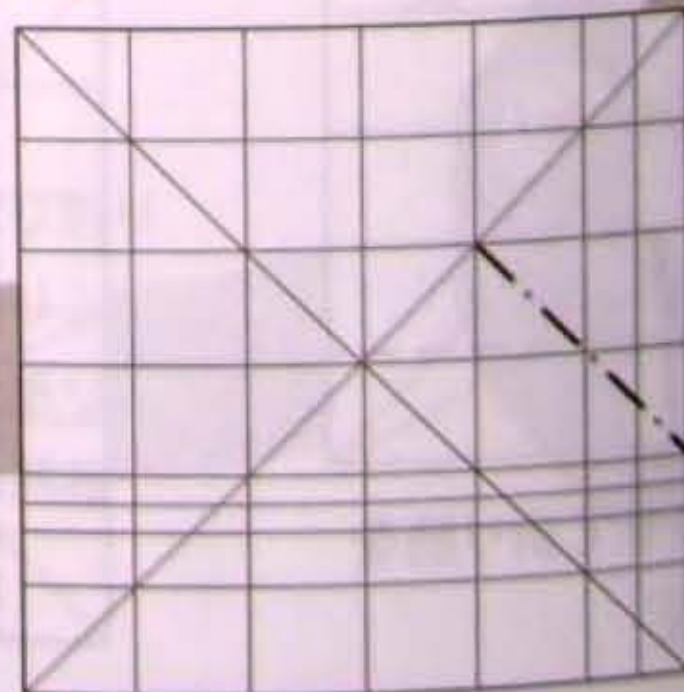

折り筋をつける

21



カドを

28



29



内側

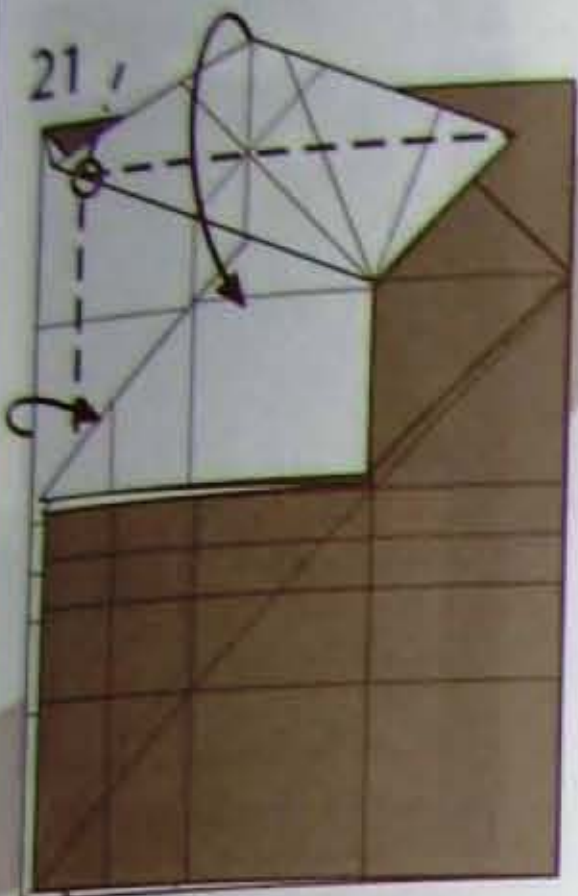

カドを倒して縁を折る

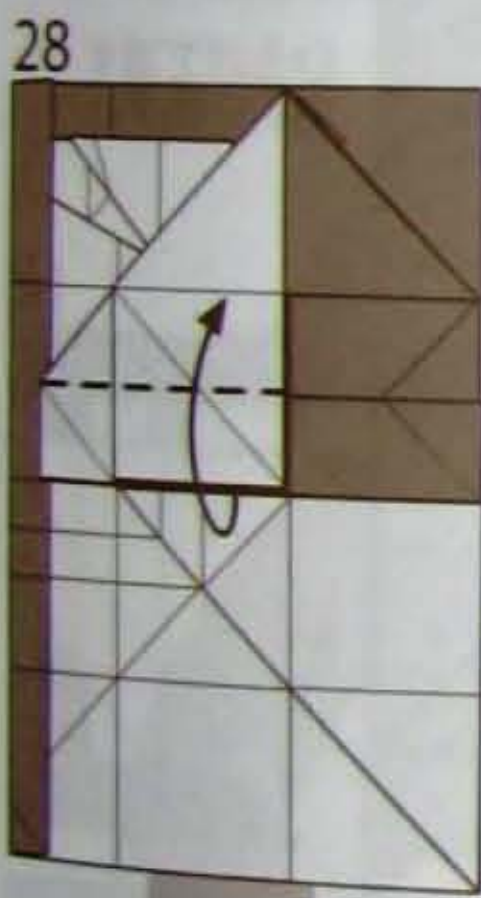

内側のカドを折る

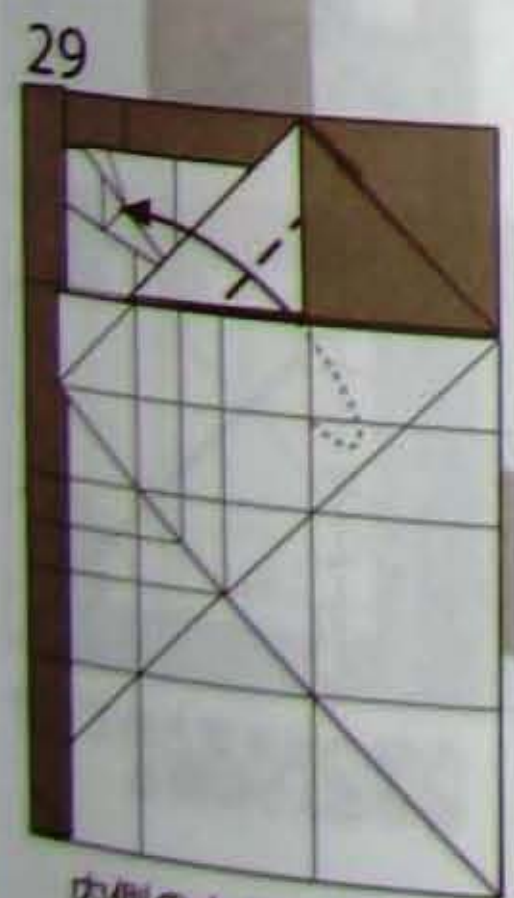

カドを一杯のところで折る

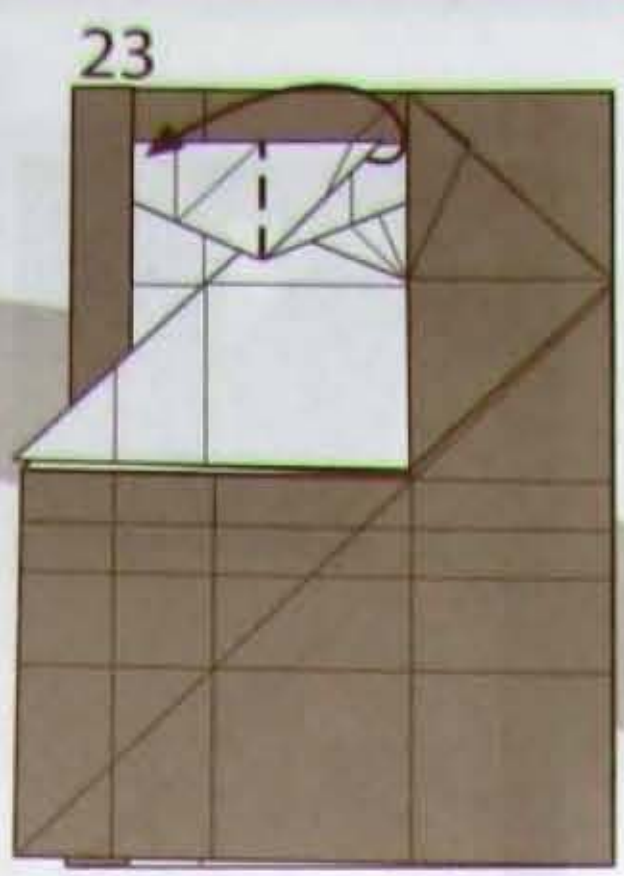
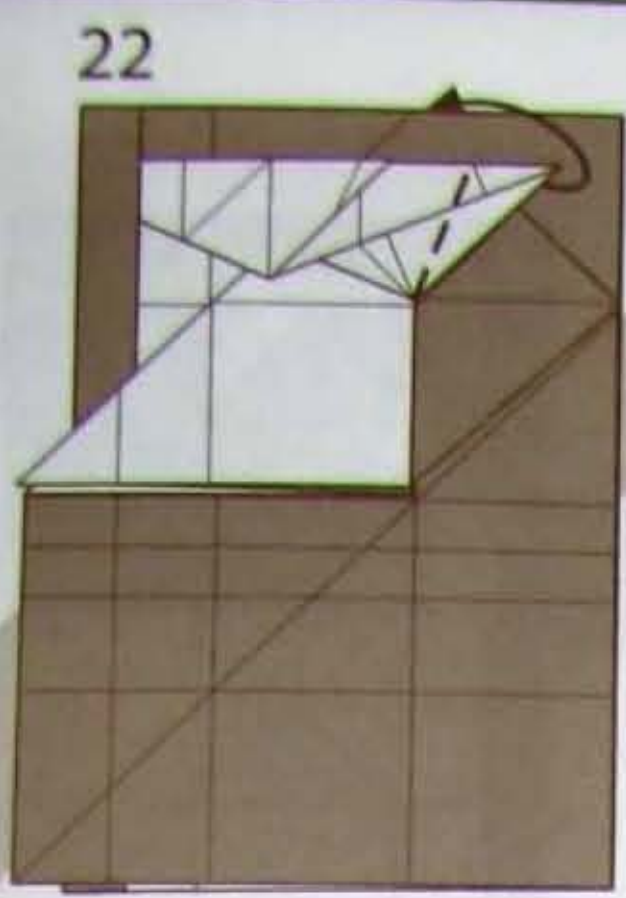

カドを一杯のところで折る

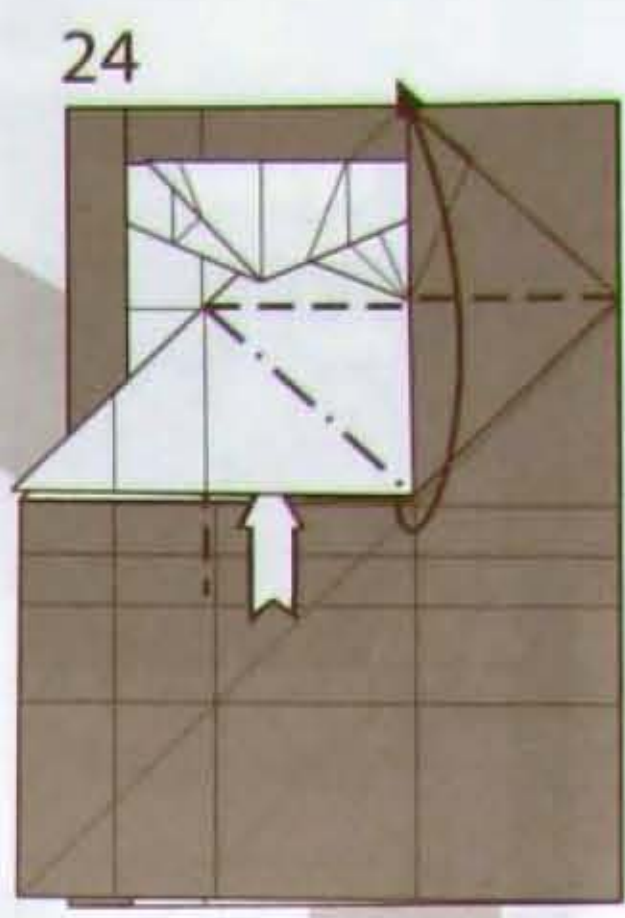

ひろげて潰す

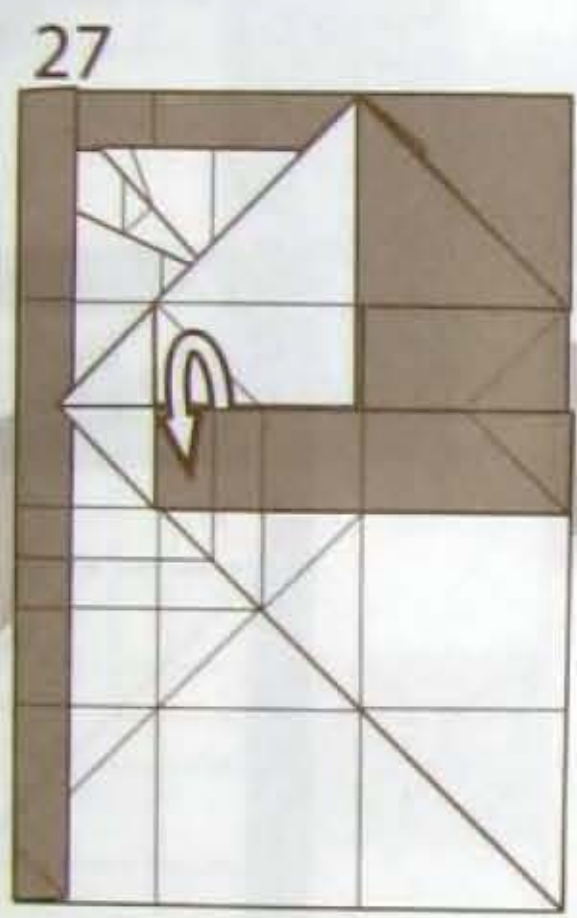

内側の紙を引き出す

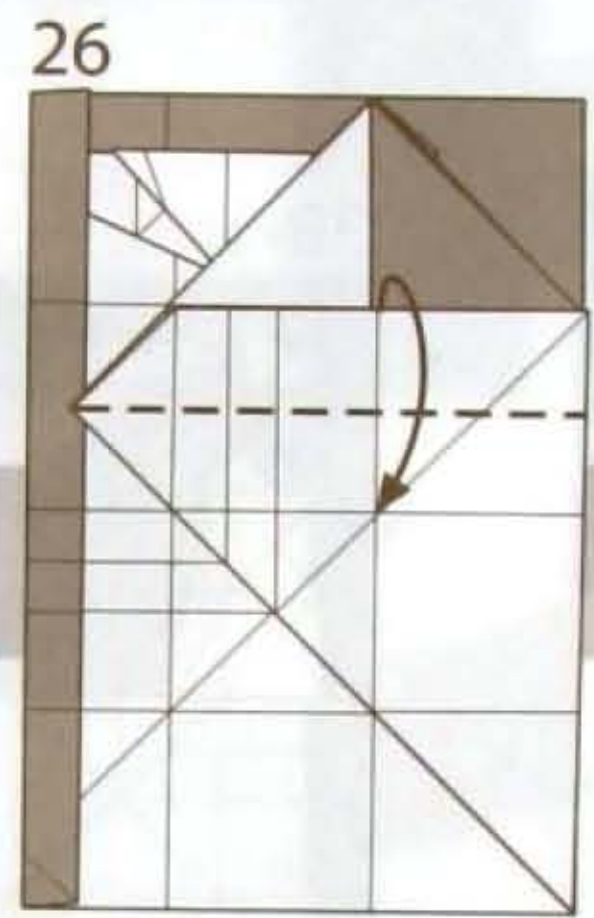

カドを折る

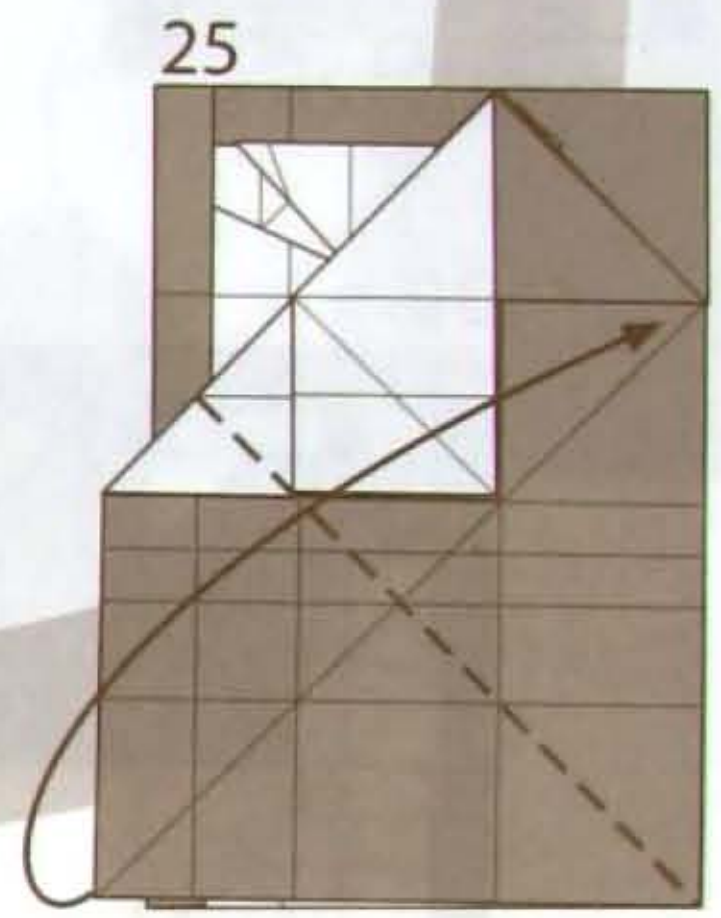

カドを折る



向こう側の紙をめくる

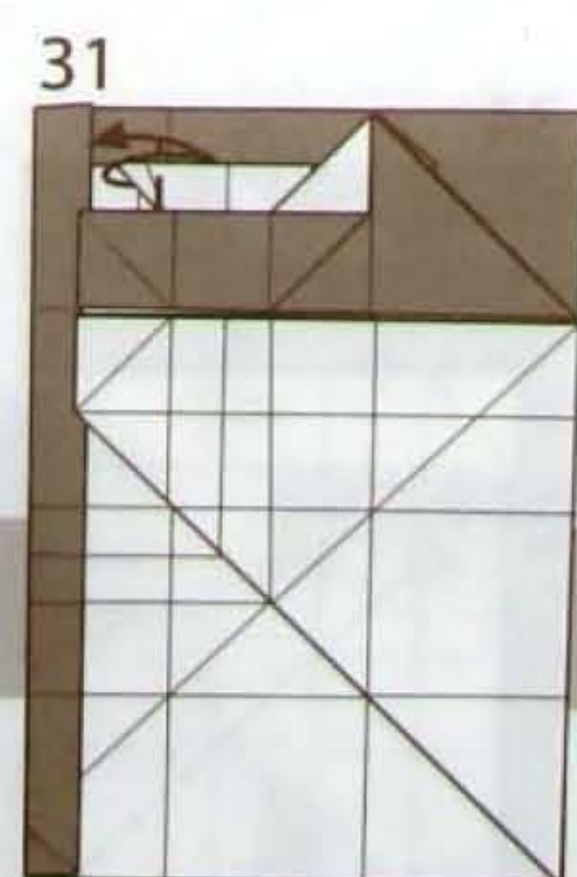

折り筋をつける

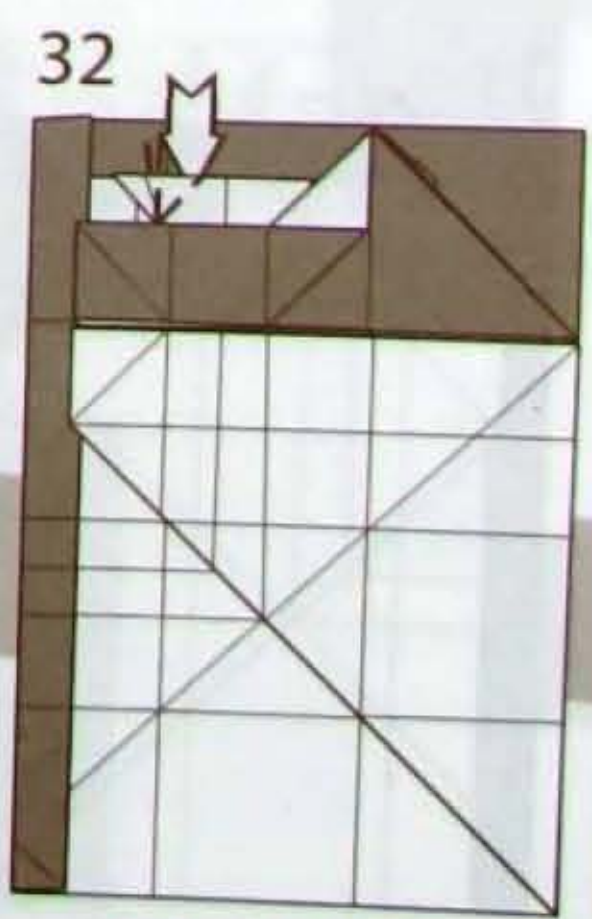

ひろげて潰す

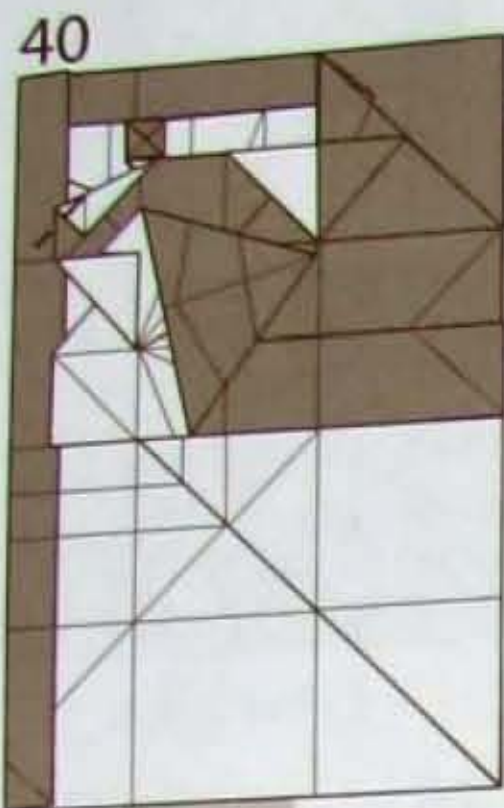

カドを小さく折る

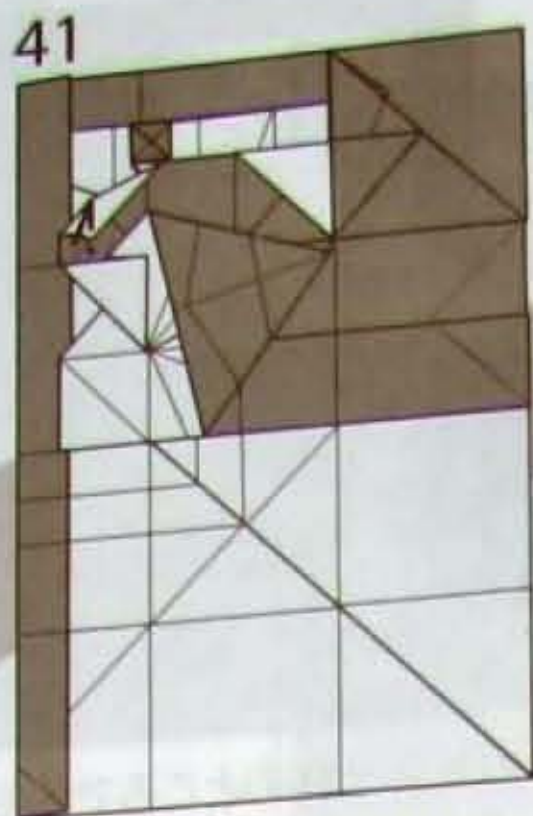

内側の紙を引き寄せる

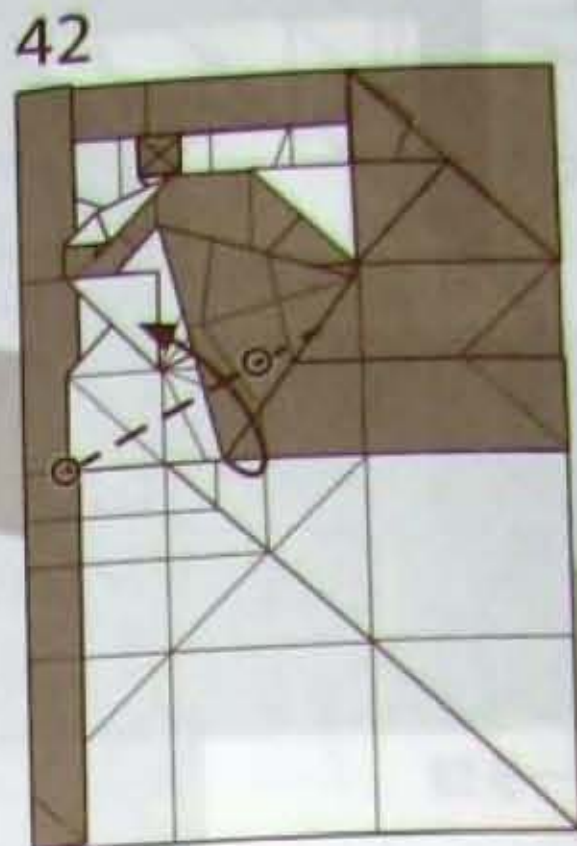

内側の紙を後ろへ倒す

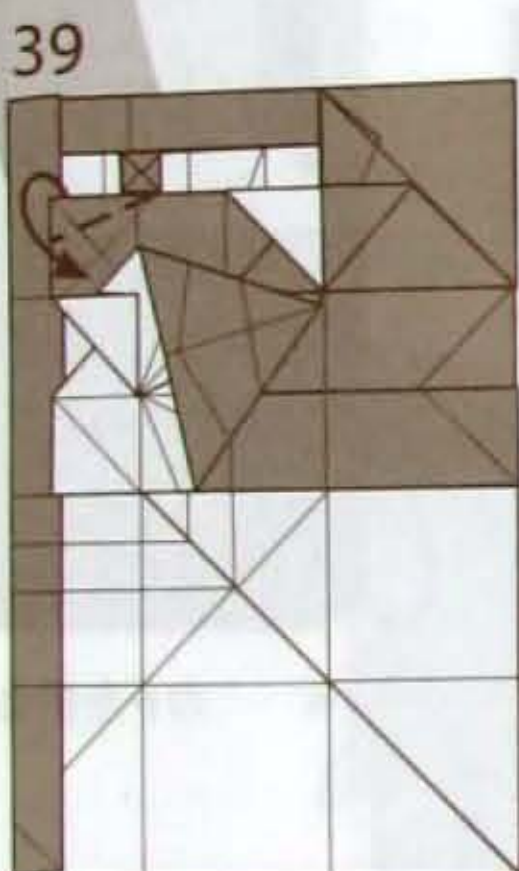

カドを半分に折る



折り筋をつける

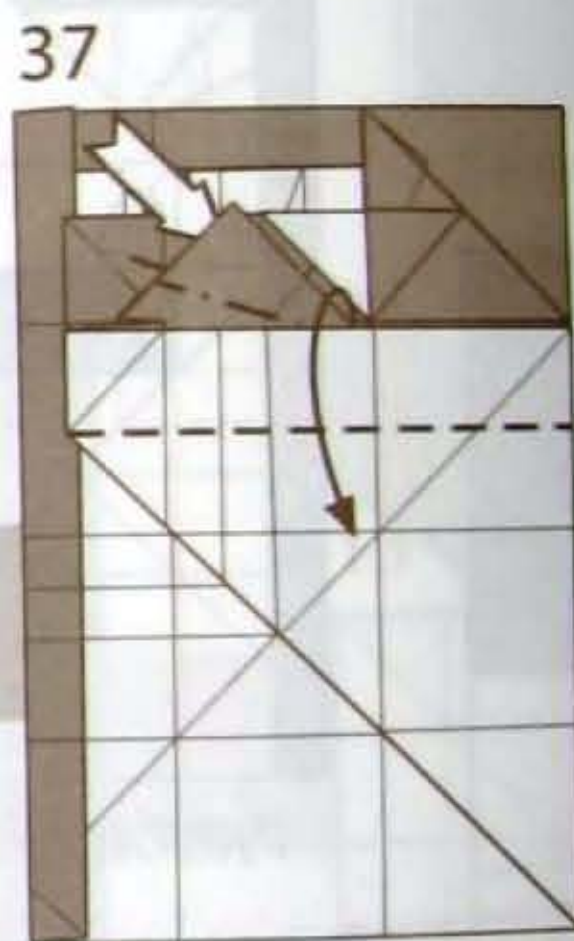

ひろげて漬す
カドを倒す

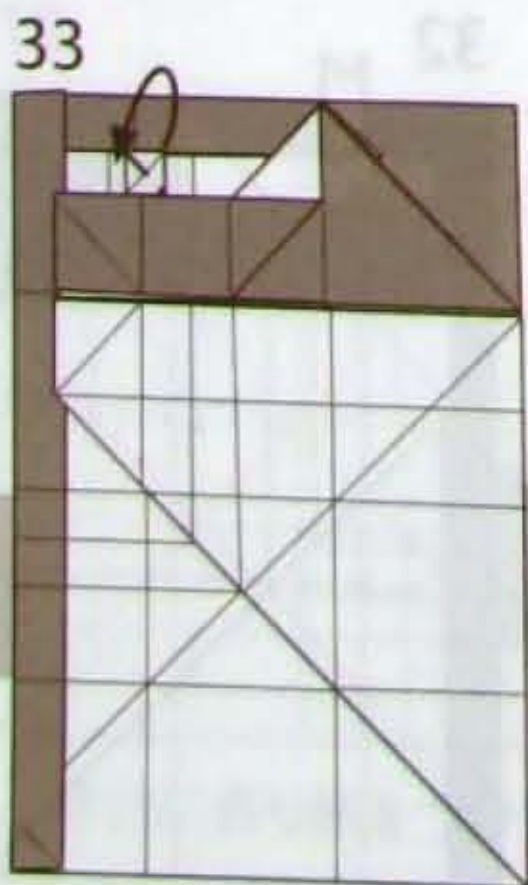

カドを半分に折る

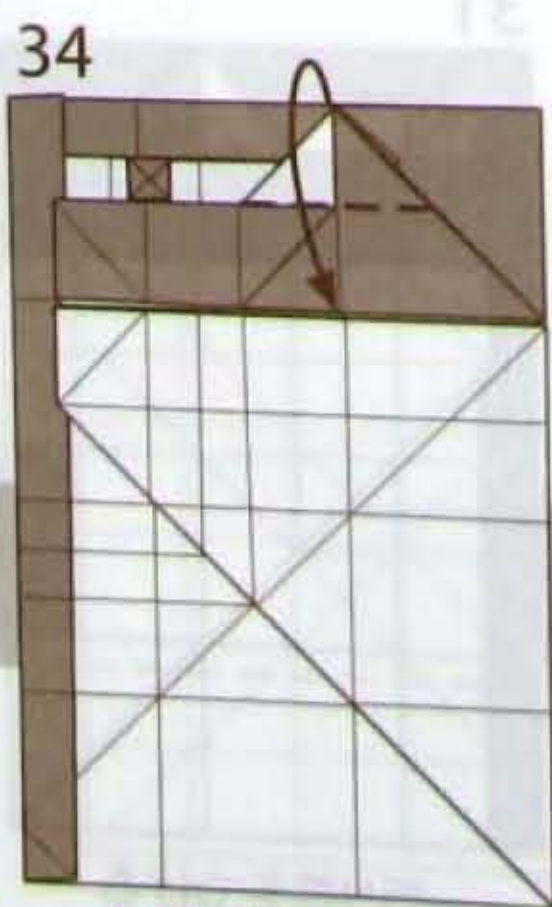

カドを半分に折る

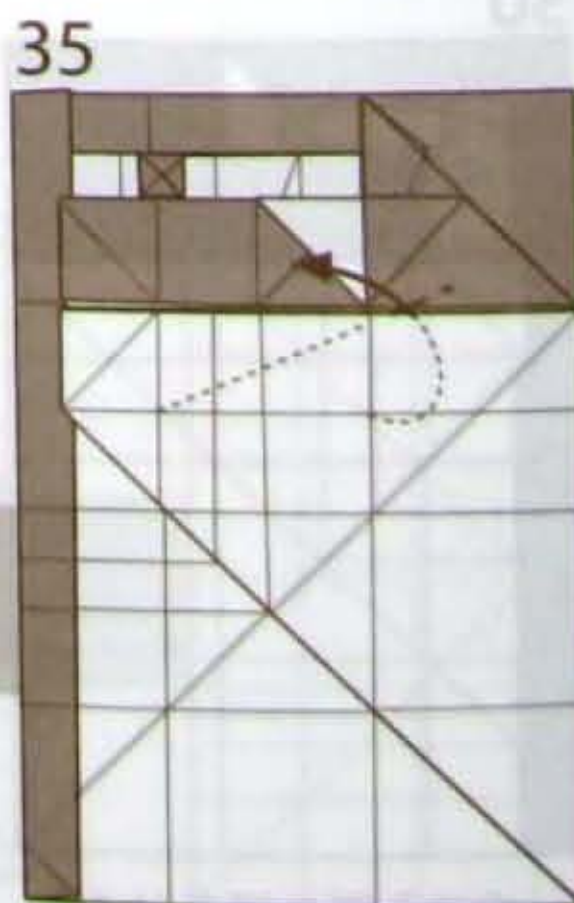

内側の紙を半分に折る



内側の紙をまとめて引き寄せるように折る



縁を





44 縁を後ろへ折りこむ

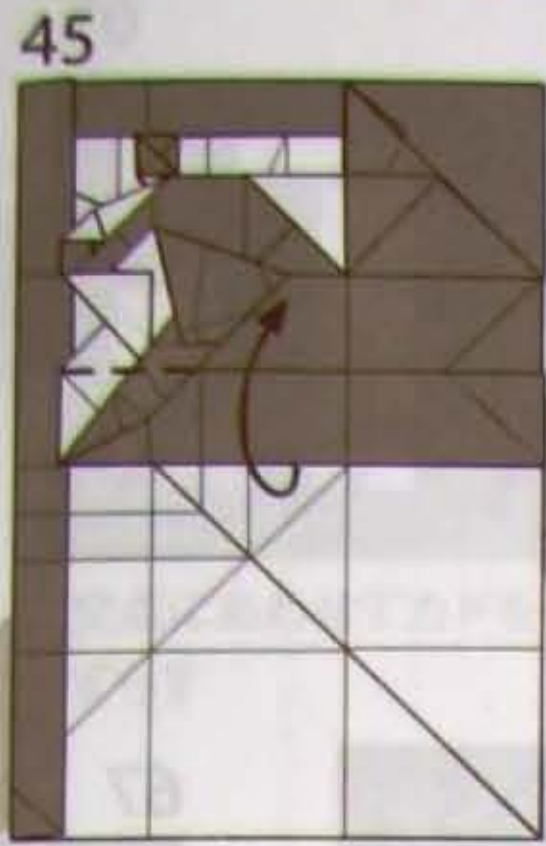

45 カドを倒す

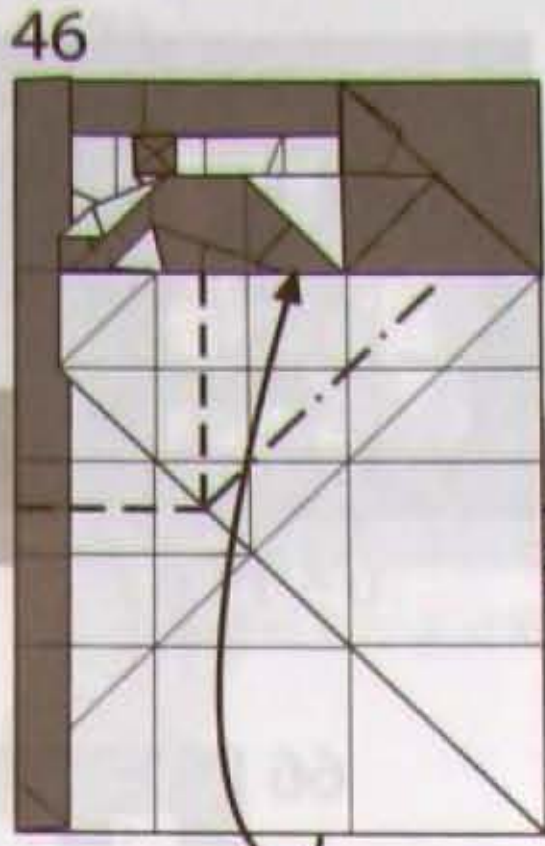

46 カドを倒す
ひろげて潰す

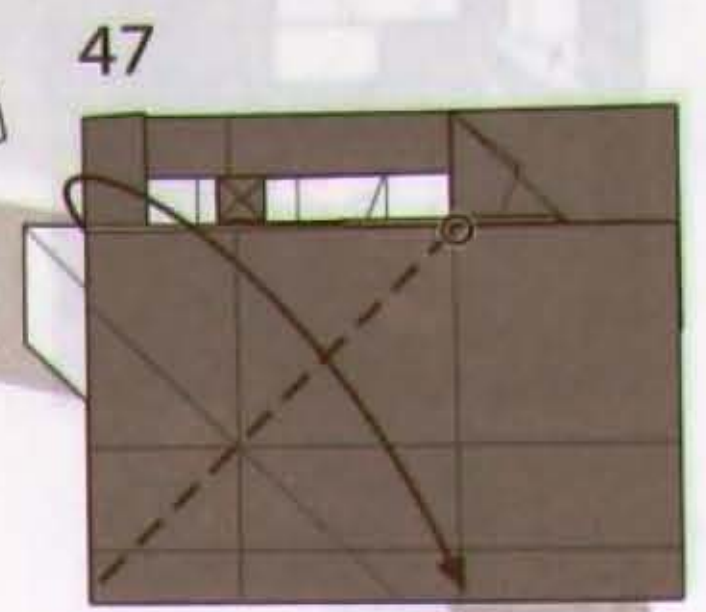

47 カドを折る
(下の縁にはあわない)

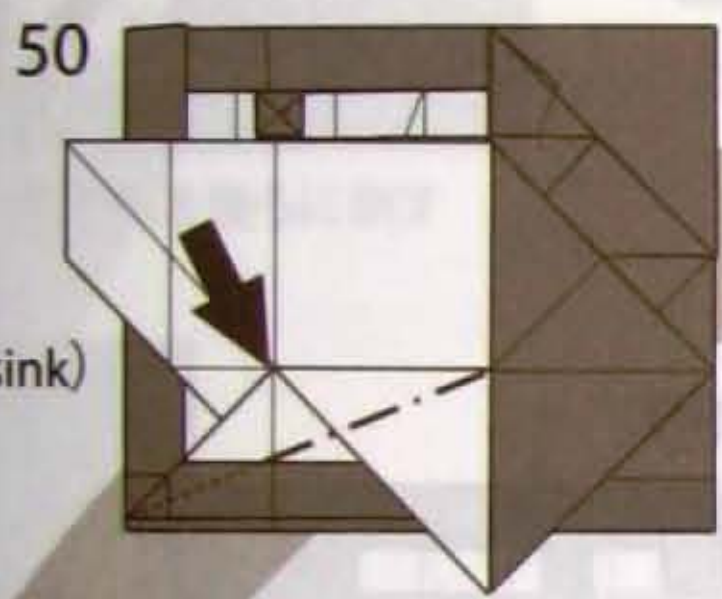

50 沈め折り
(closed-sink)

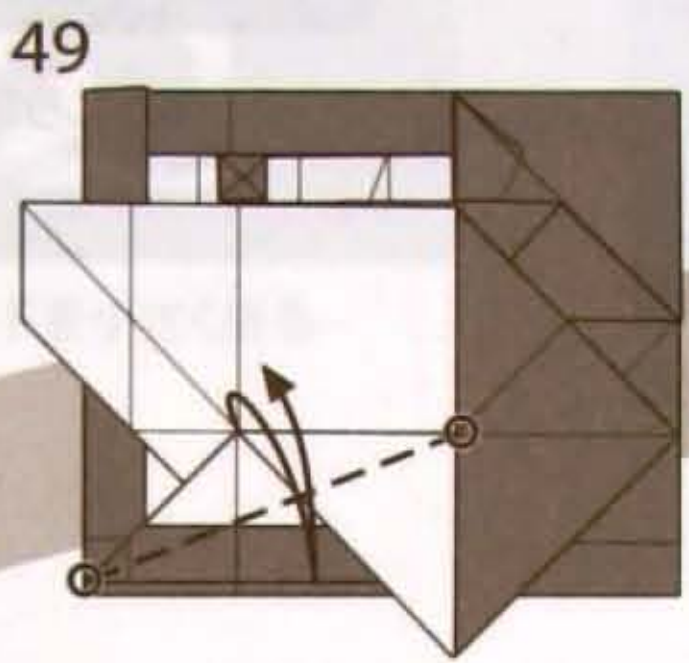

49 折り筋をつける

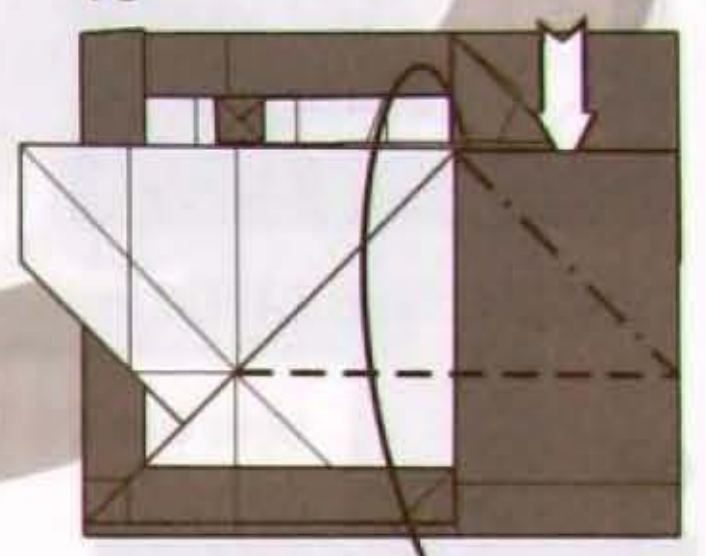

48 ひろげて潰す

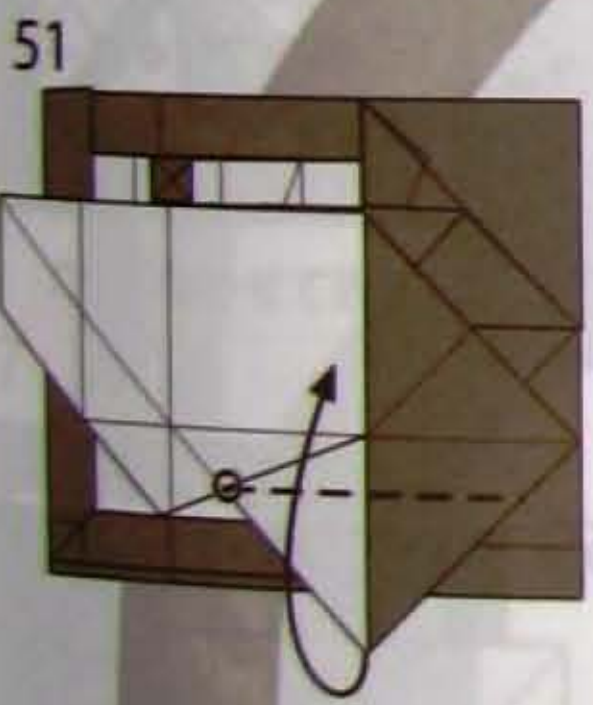

51 カドを一杯の
ところで折る

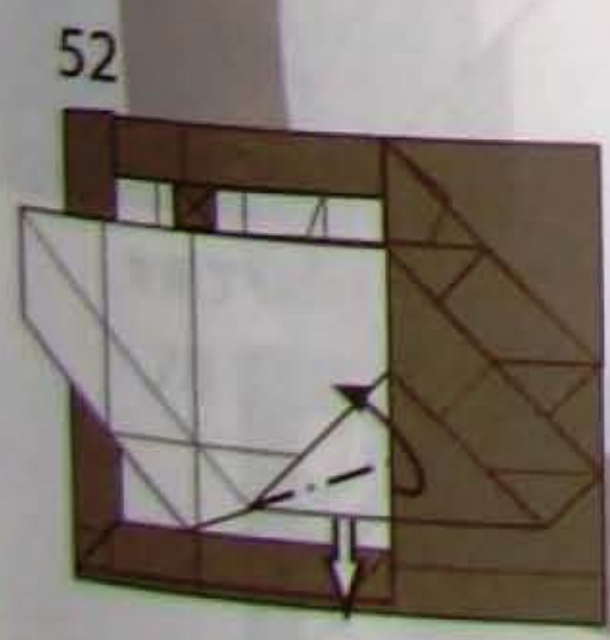

52 紙を引き出す

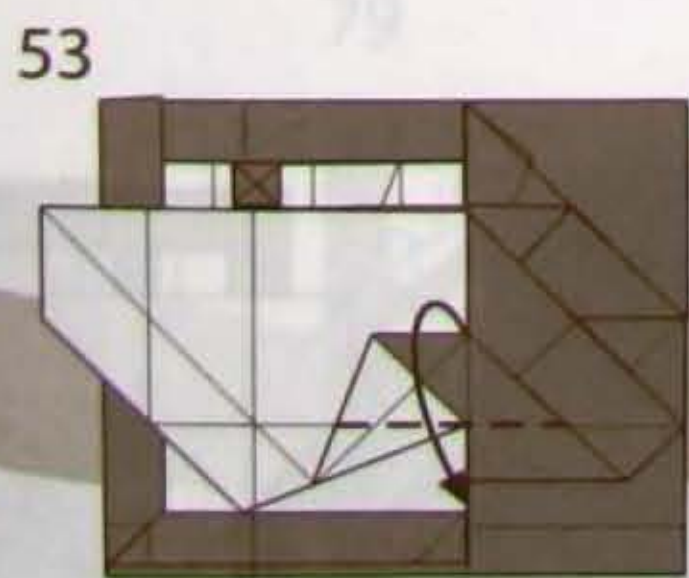

53 うしろの折り線にあわせ
て折る

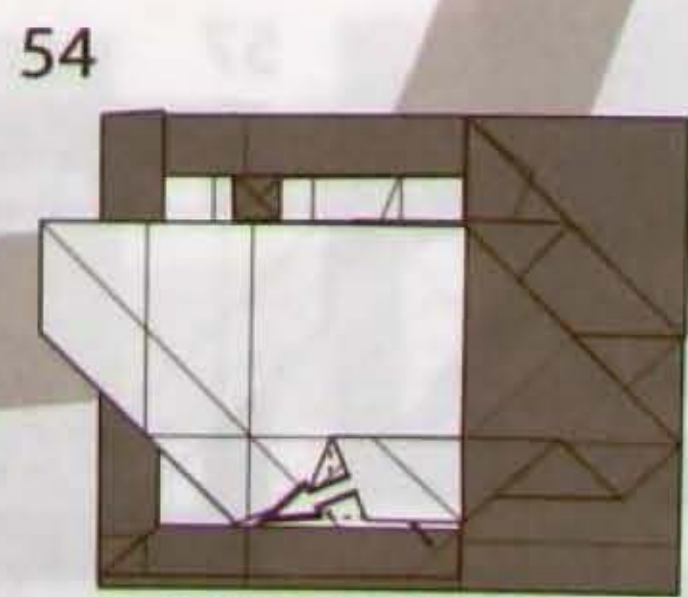

54 内側の紙を引き出す

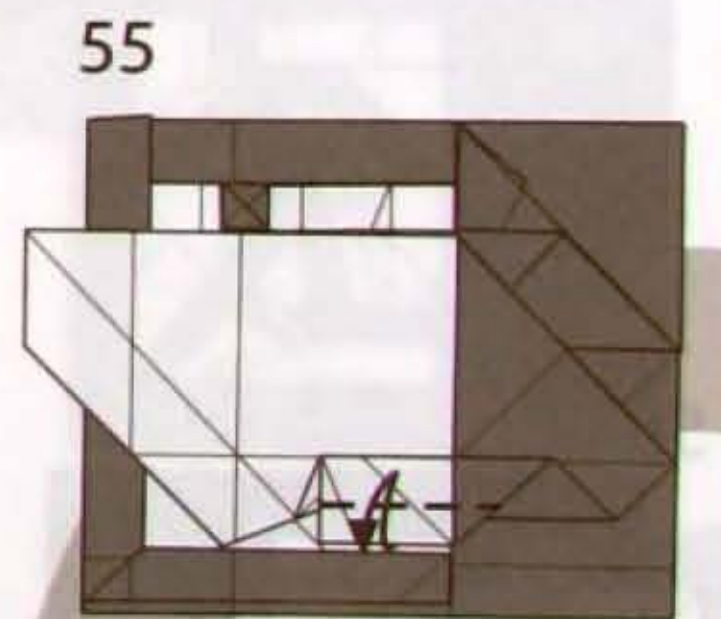

55 一杯のところで折り筋をつける

64

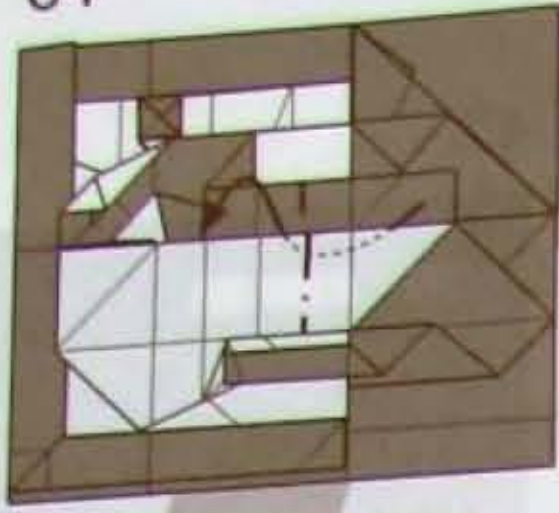

折り筋で中割り折り

63

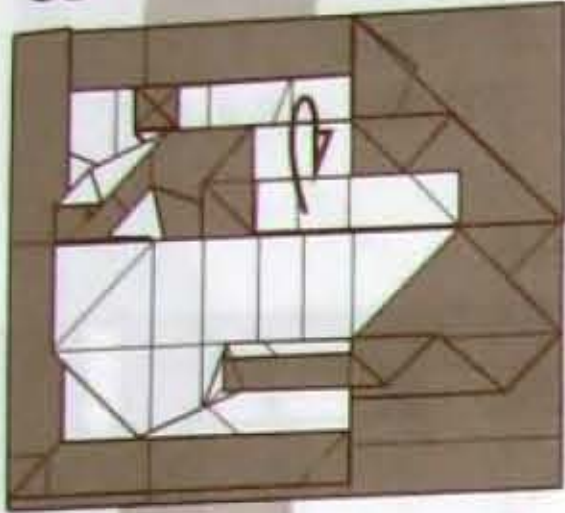

上の紙をうしろに折りこむ

62

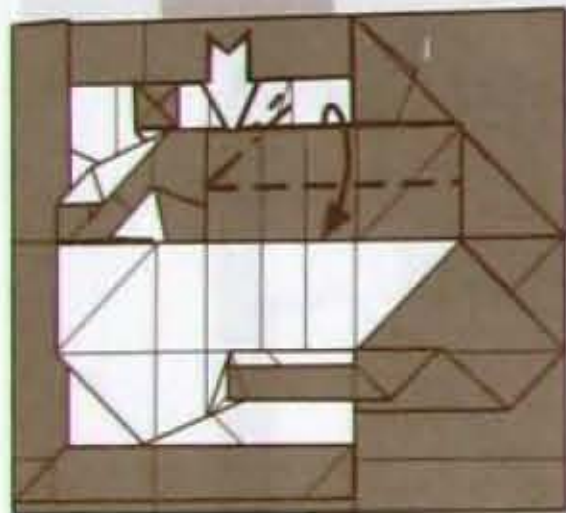

ひろげて潰す

56

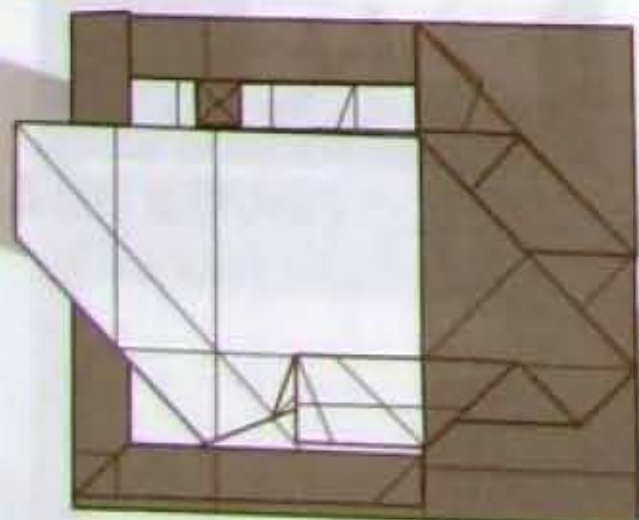

53の状態まで紙をひろげる

65

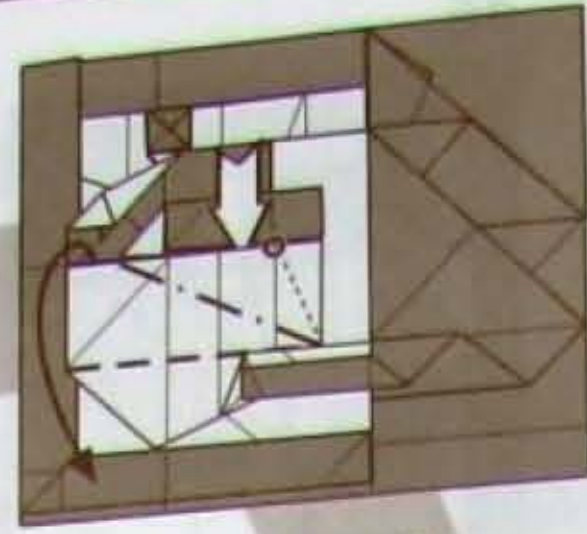

ひろげて潰す

66

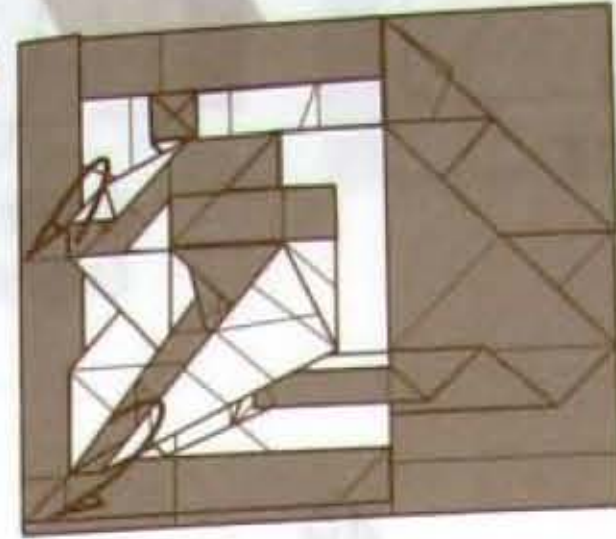

カドをうしろに隠す

67

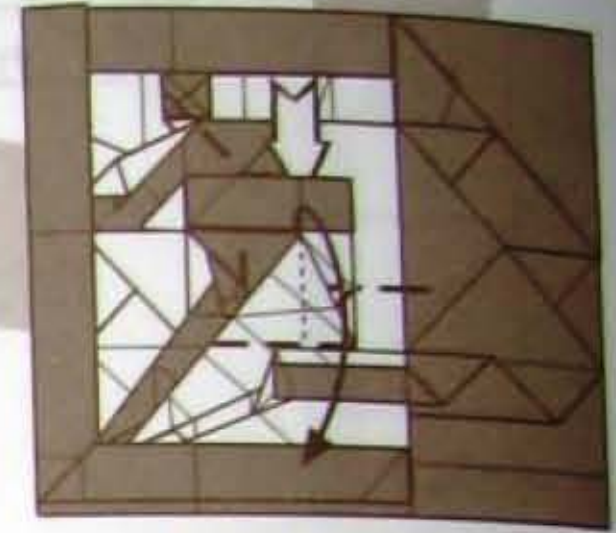

ひろげて潰す

68



ひろげて潰す

69



カ

61

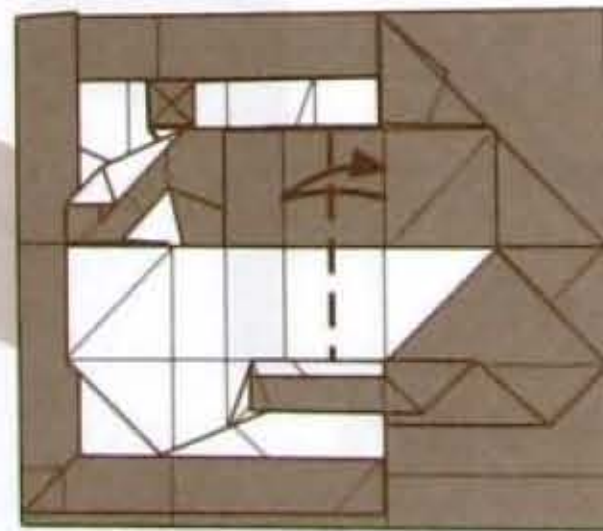

半分に折り筋をつける

60

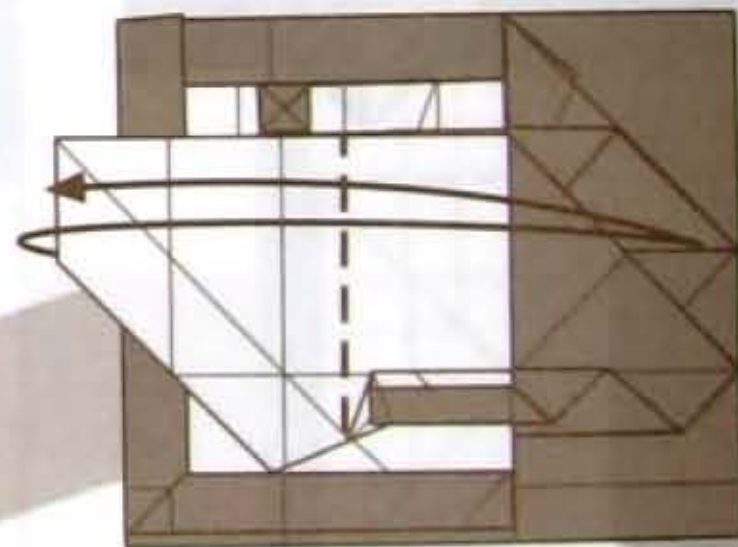

一杯のところで折り筋をつける

59

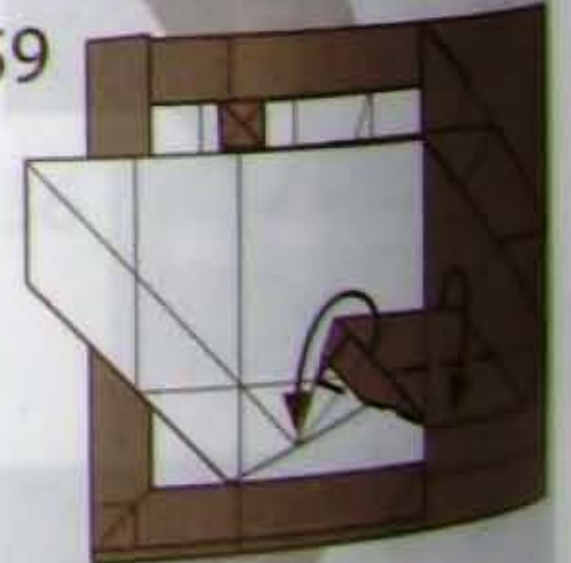

ひろげて潰す

57

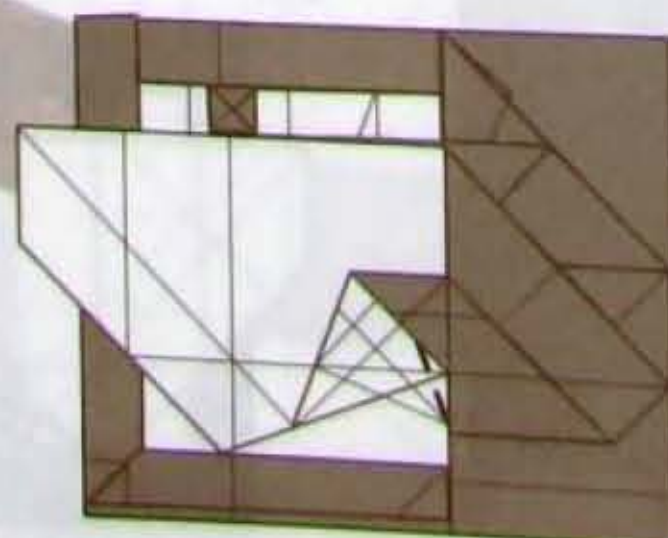

カドを小さく折る

58

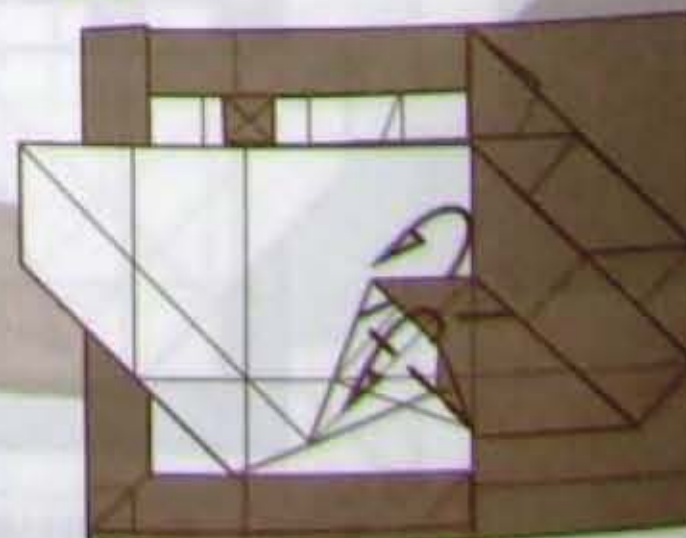

折り筋で後ろに折り込む

76



カド

77



縁を

69

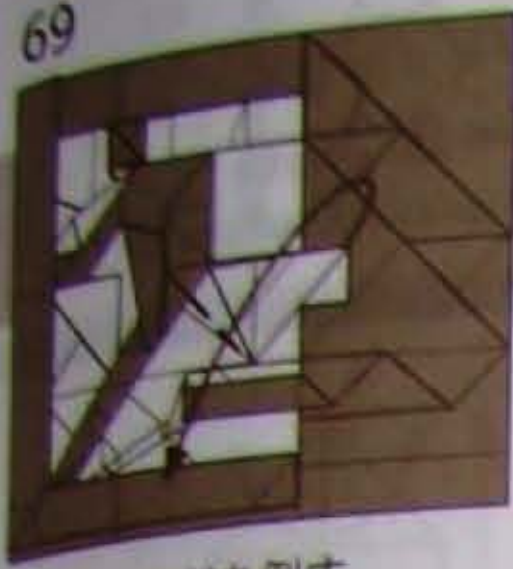

カドを倒す

70

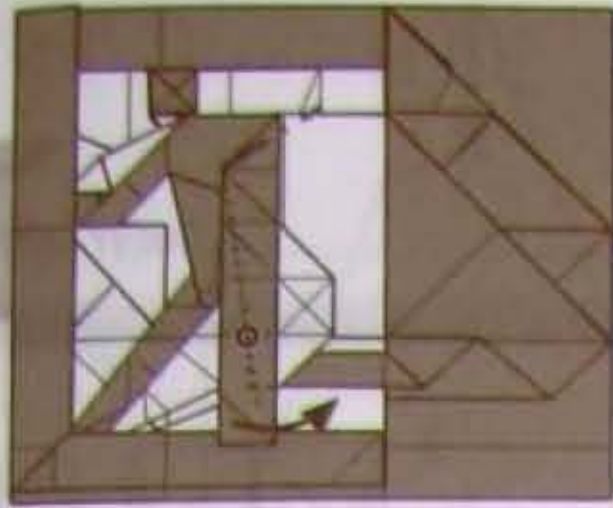

交点にあわせてカドをずらす

71

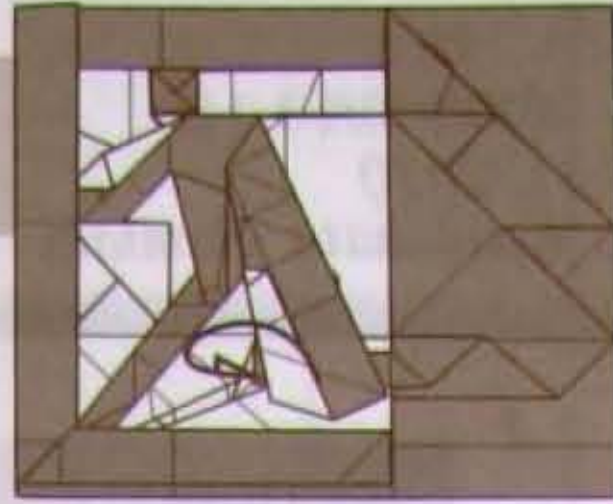

手前の紙をかぶせ折り

72

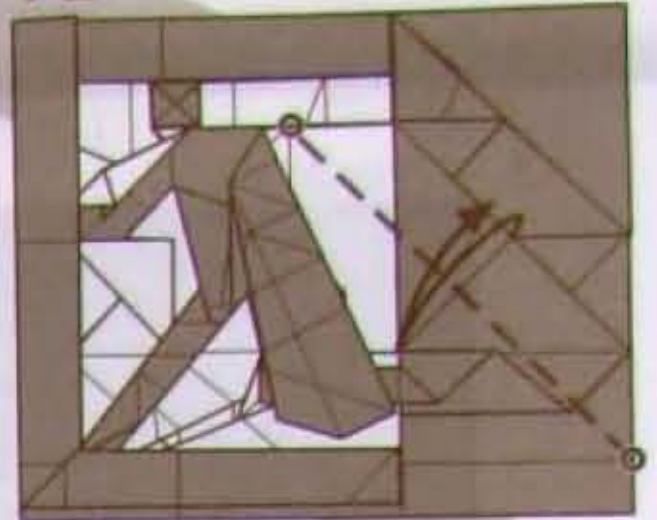

折り筋をつける

74

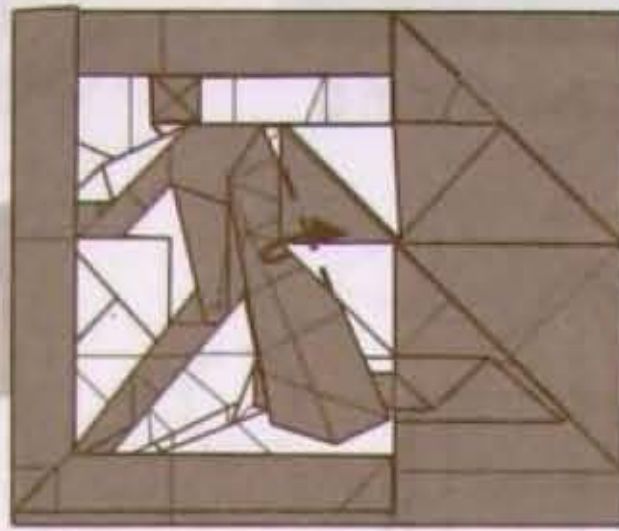

カドを小さく折る

73

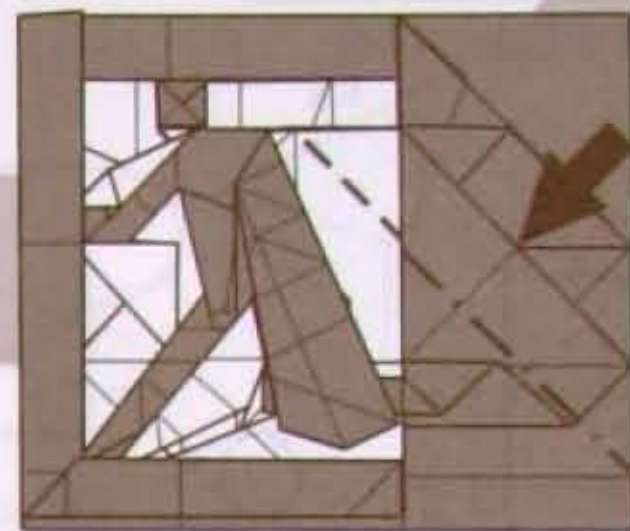

沈め折り (closed-sink)

75

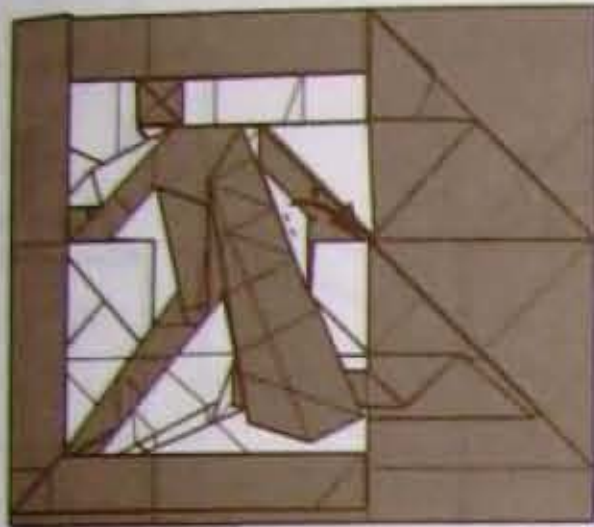

内側の紙を後ろに倒す

76

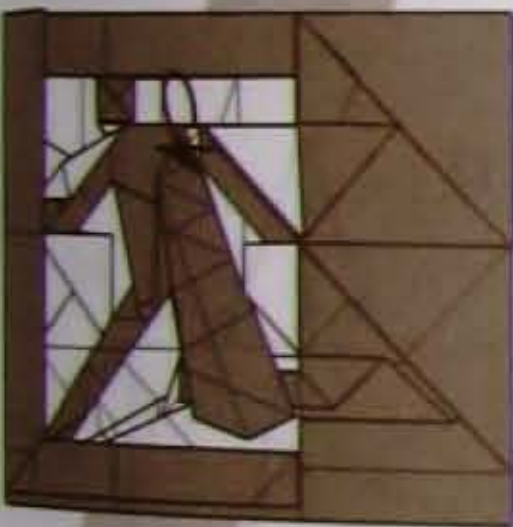

カドを合わせて折る

82

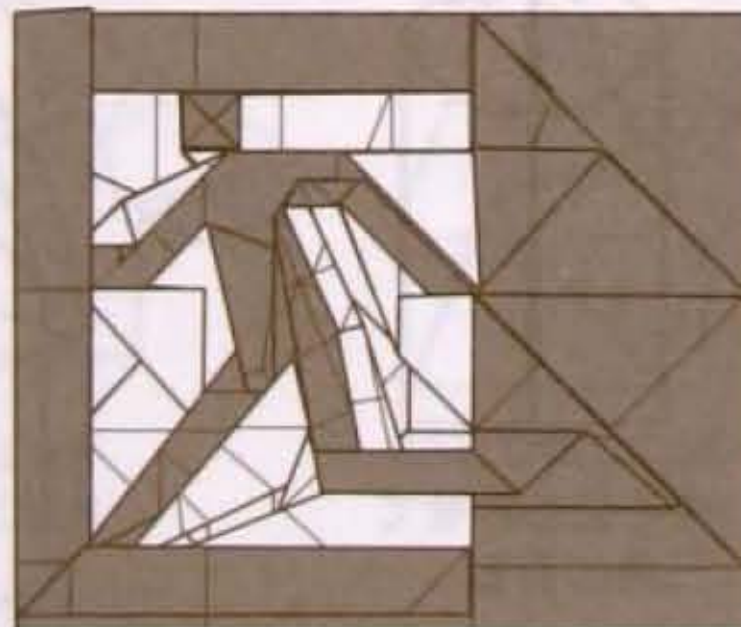

完成

81

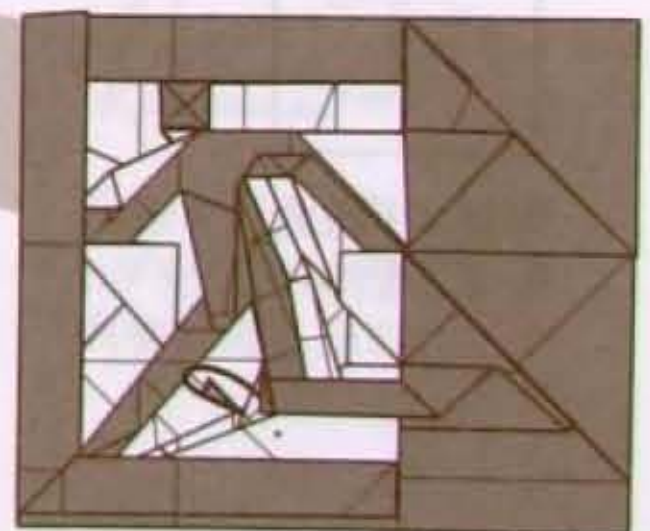

カドを小さく折る

77

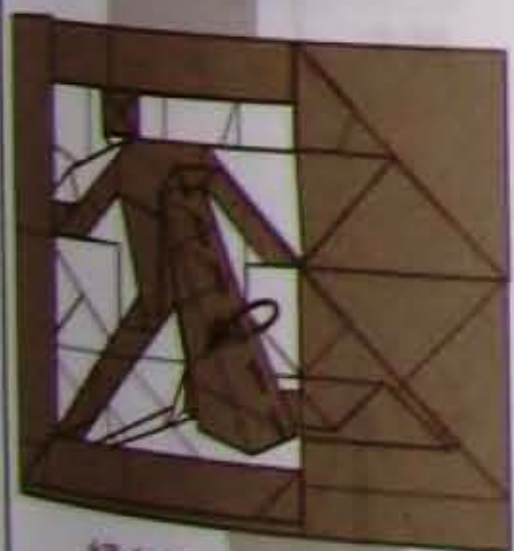

線を細く折る

79

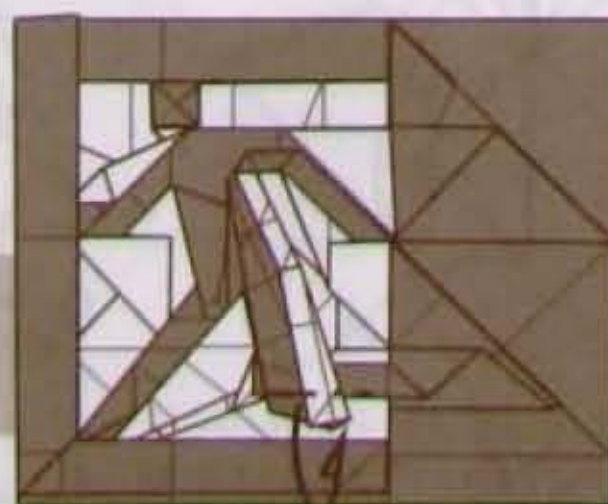

カドをうしろの縁に合わせて折る

80

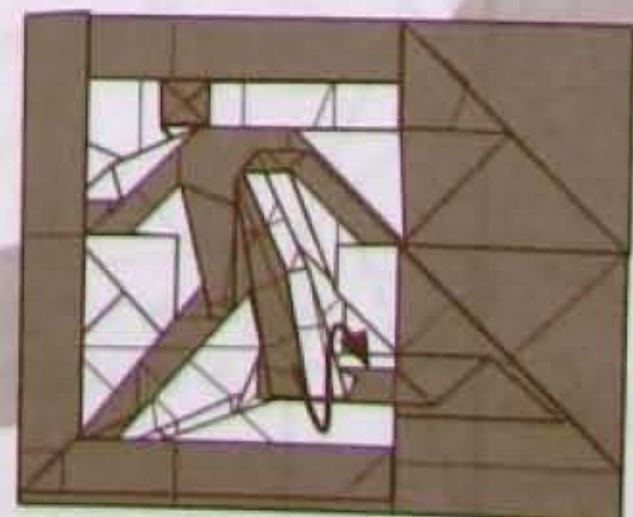

カドをすぐうしろに差し込む

78

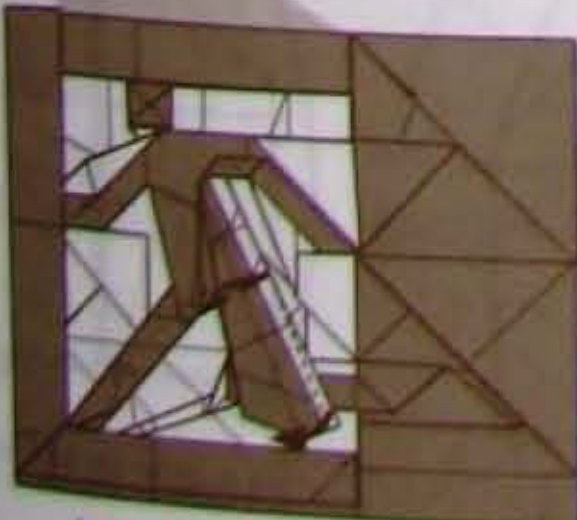

紙を下半分だけずらす

Japão Burajirujin

www.japaoburajirujin.blogspot.com

ウサギ

川畑文昭 2010年10月31日
October 31, 2010
Kawahata Fumiaki



Copyright By Fumiaki Kawahata 2011

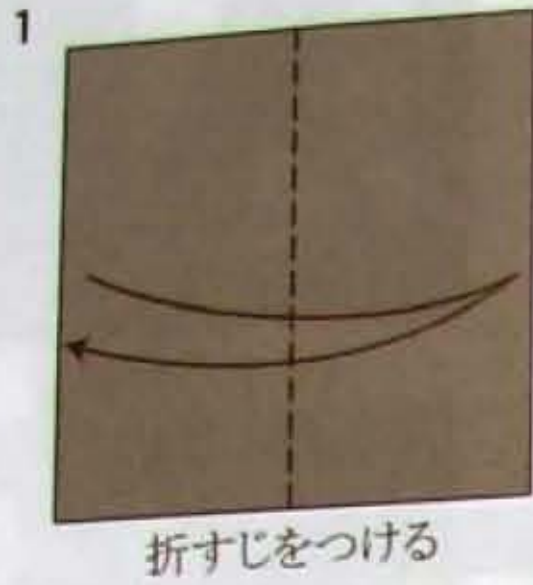

折すじをつける

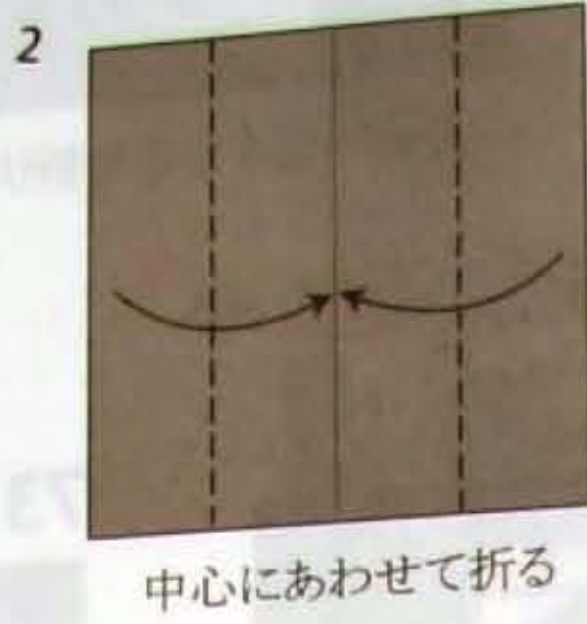

中心にあわせて折る

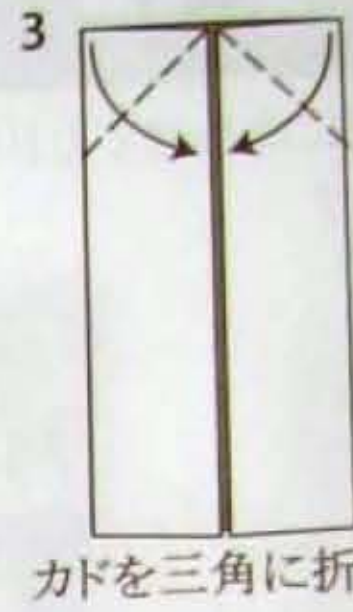

カドを三角に折る

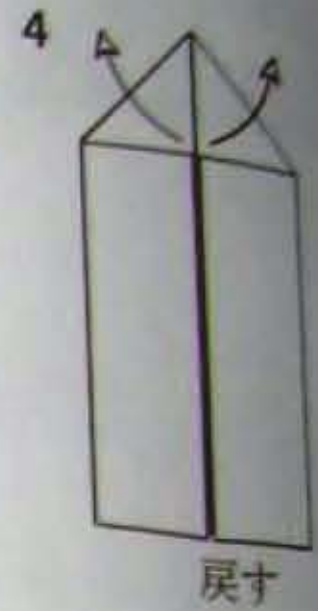

戻す

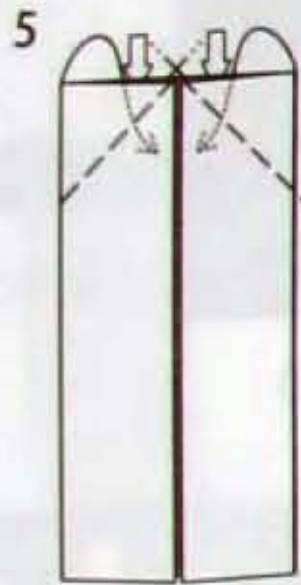

中わり折り



裏返し

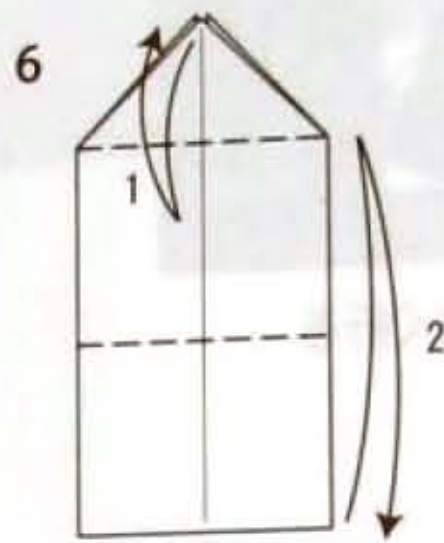

折すじをつける

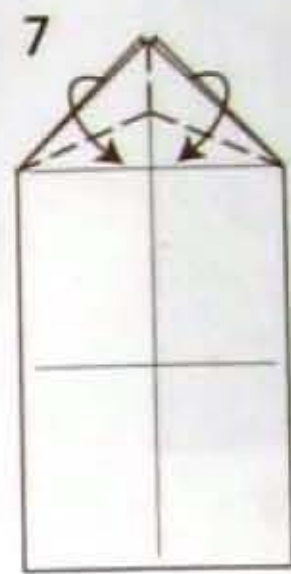

カドをつまむように折る

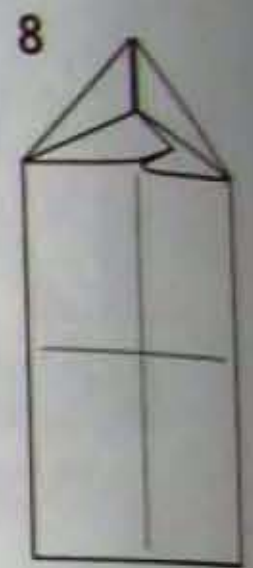

途中図

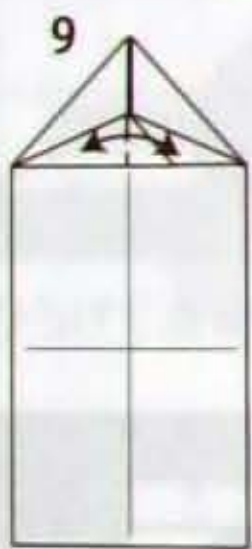

両側に折り返し
折すじをつける



裏返し



中心にあわせて
三角に折る

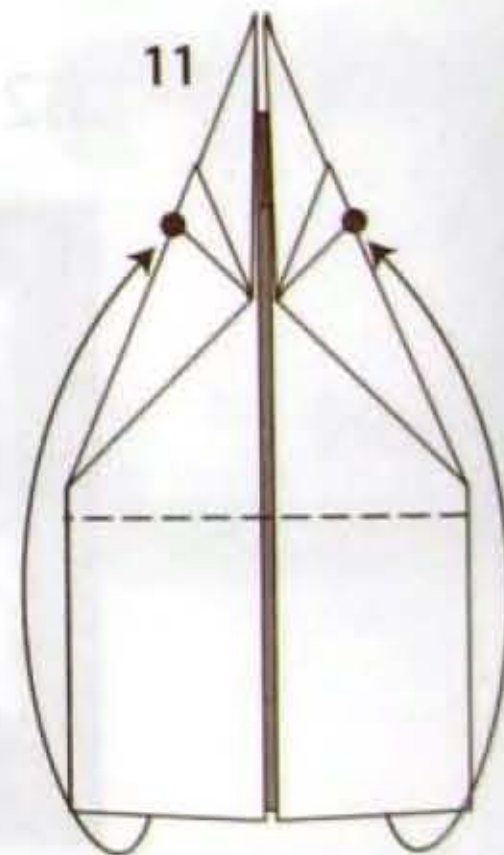

6でつけた折すじをつかって
下の辺を●にあわせて折る

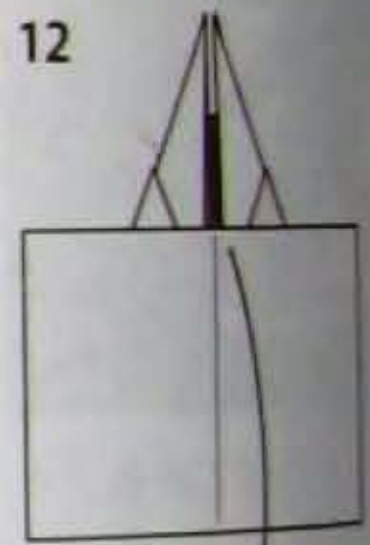

戻す

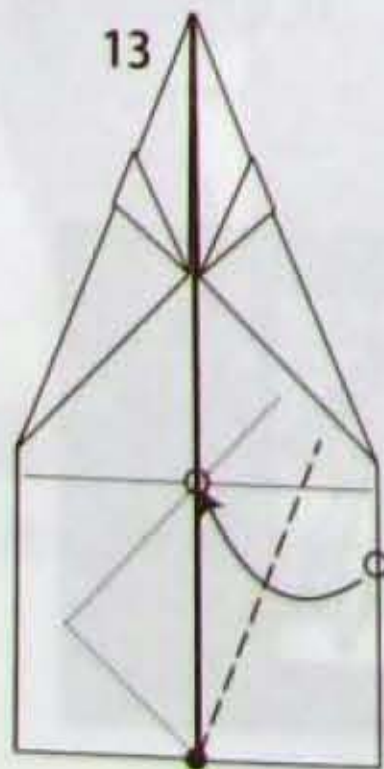

辺の○が、中央の○に
重なるように折る

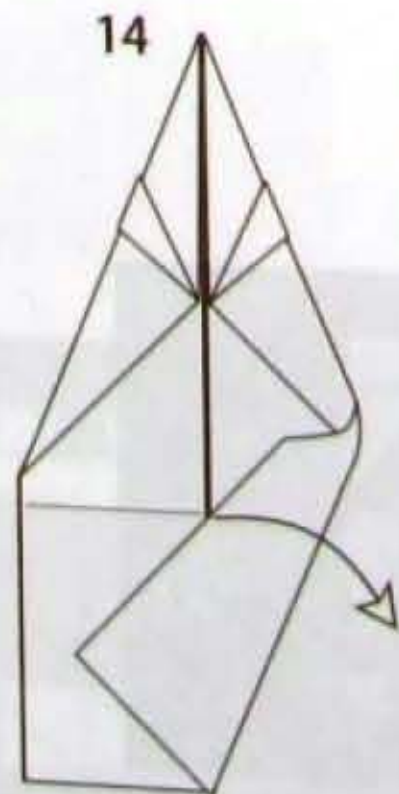

戻す

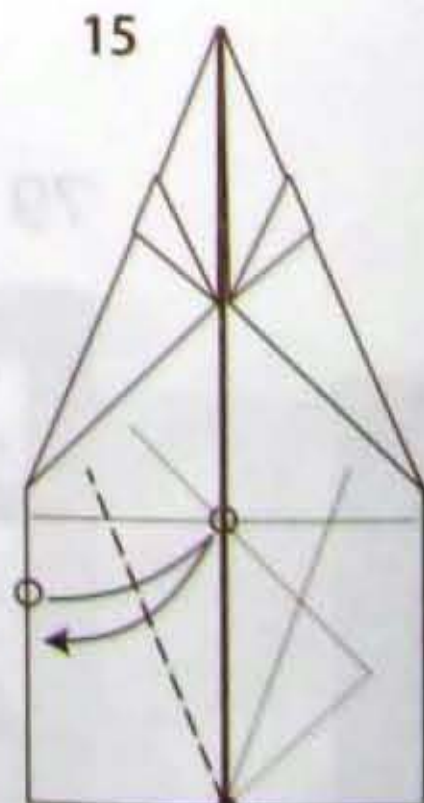

左側も13~14と
同じように折る

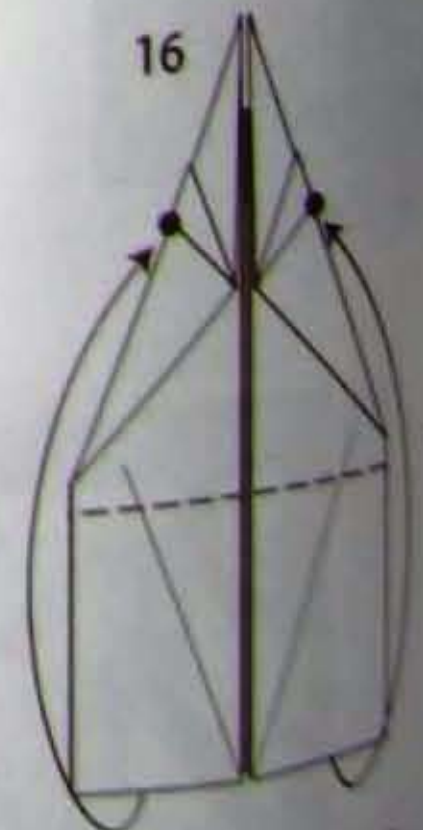

11と同じ位置で折る

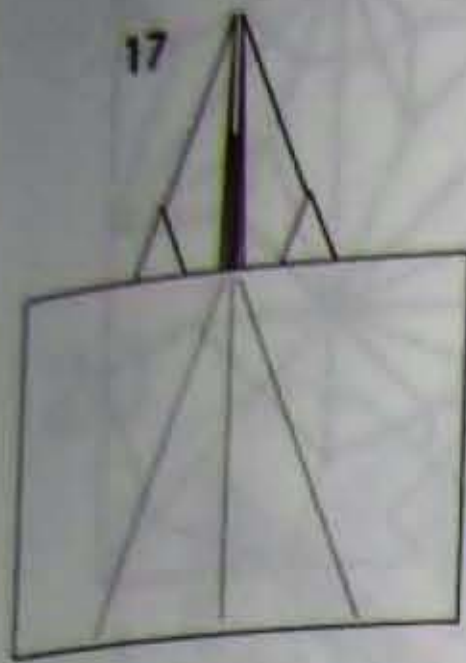

17



裏返し

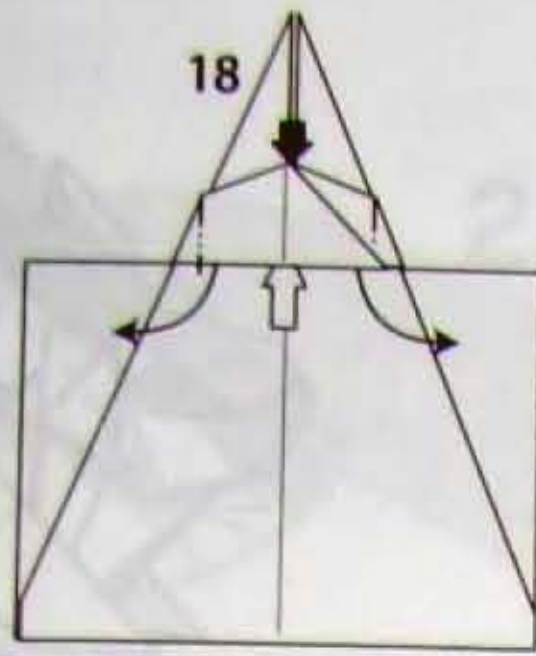

広げて平らにつぶす

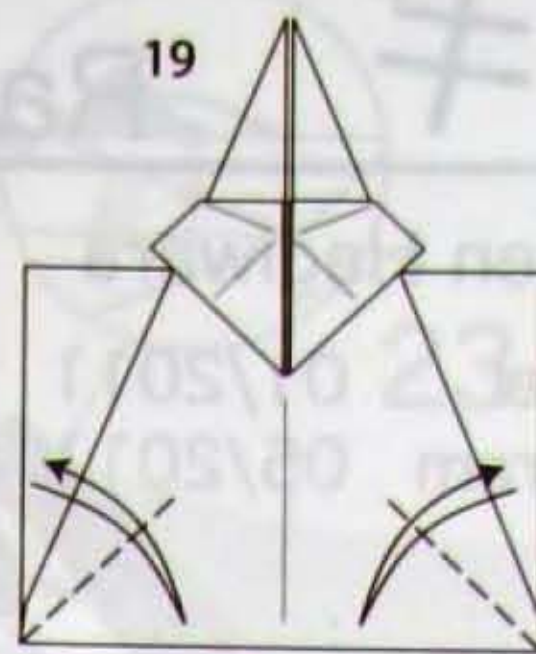

折すじをつける



裏返し

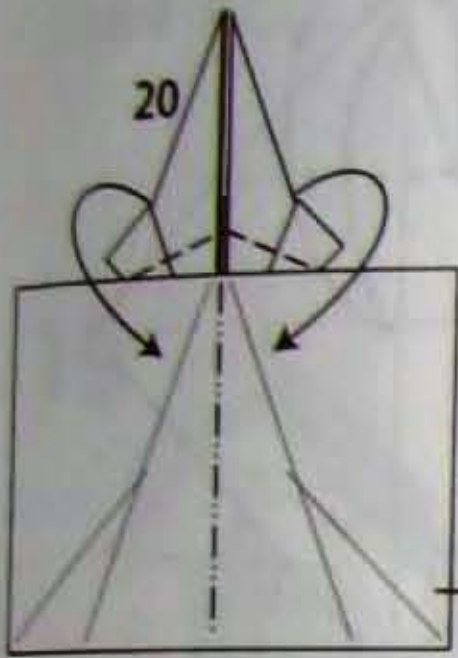

20

首元を斜めに折りながら
全体を山に折る

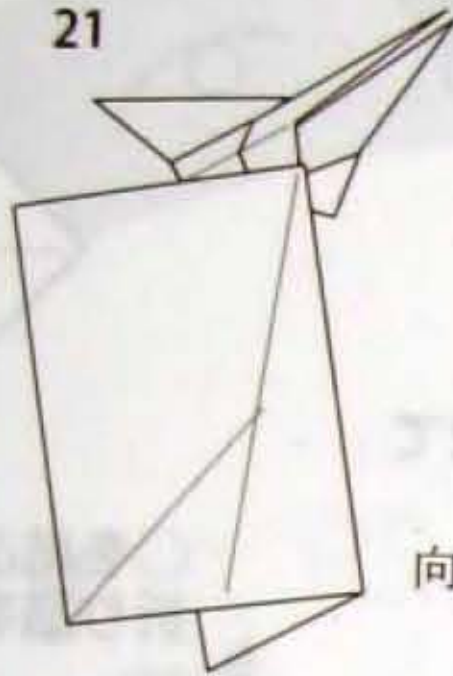

21

途中図



向きを変える

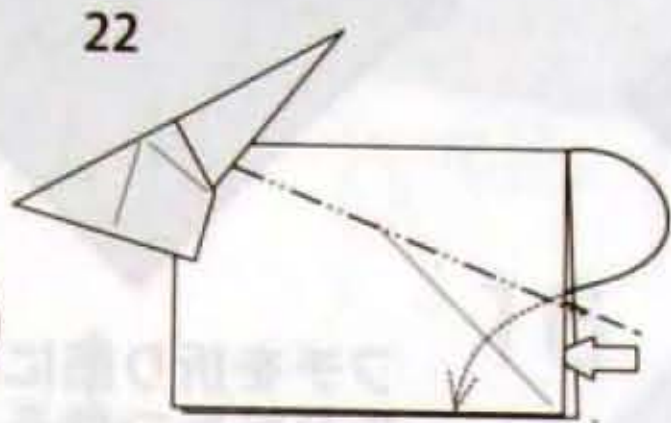

22

13~15でつけた
折りすじをつかって
中わり折り

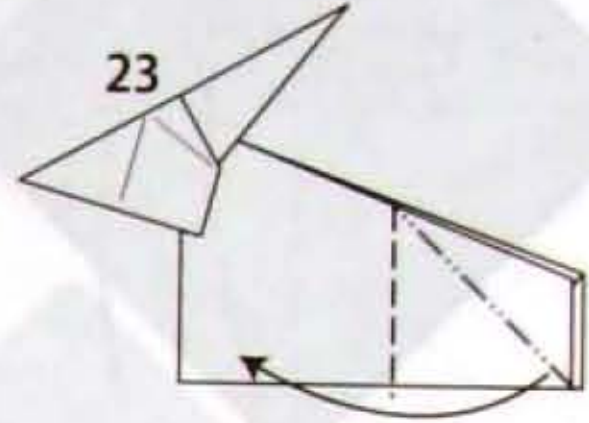

23

19でつけた
折りすじをつかって
カドをつまむように折る

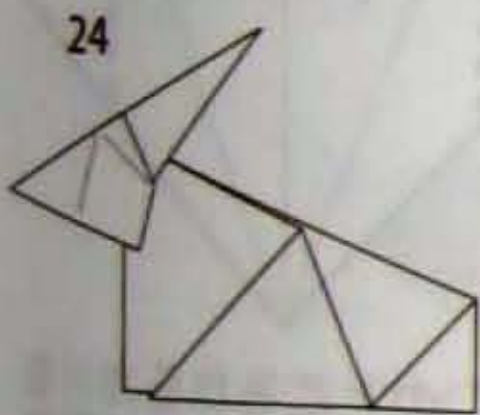

24

23まで折った形



裏返し

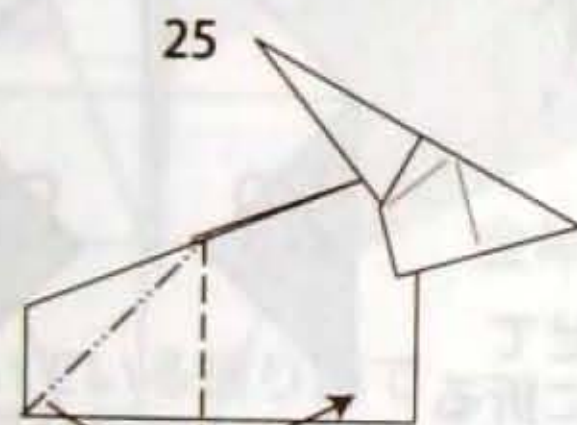

25

反対側も23と
同じように折る

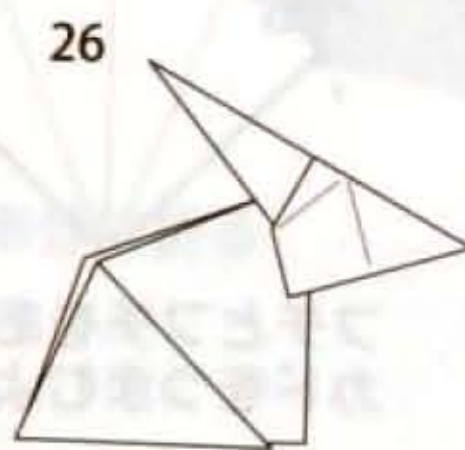

26

25まで折った形

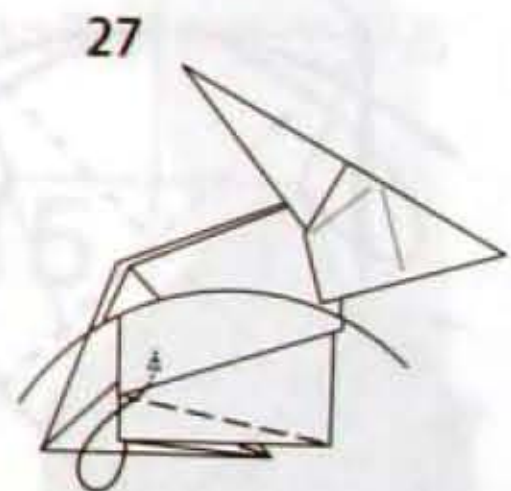

27

内側を見た図
ヒダを三角に折って
内側に差し込む

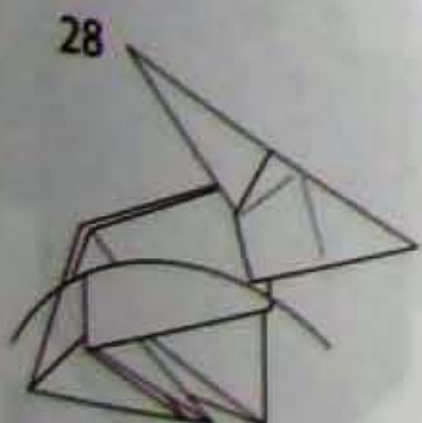

28

27まで折った形
反対側も同じように折る

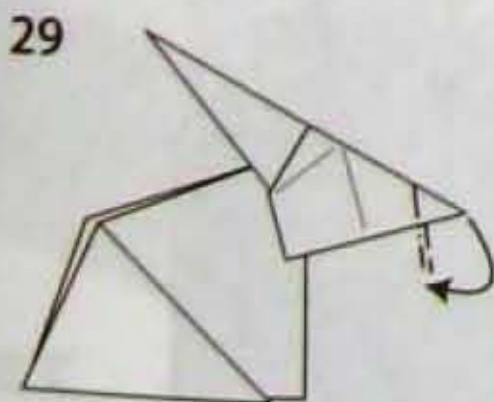

29

顔の先を中わり折り



30

下から指をいれて
背中を平らにひろげ
全体を膨らませる

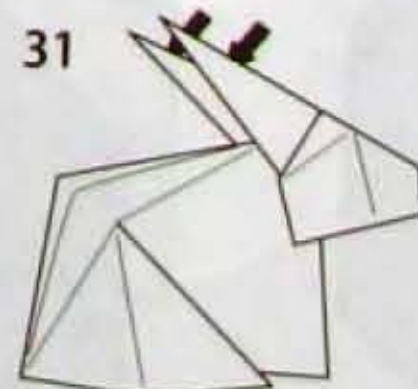

31

耳を広げて赤い色が
見えるようにする



32

出来上がり

拡大

ウサギ Rabbit

萩原元 / Gen Hagiwara

創作 / Model 01/2011

作図 / Diagram 05/2011

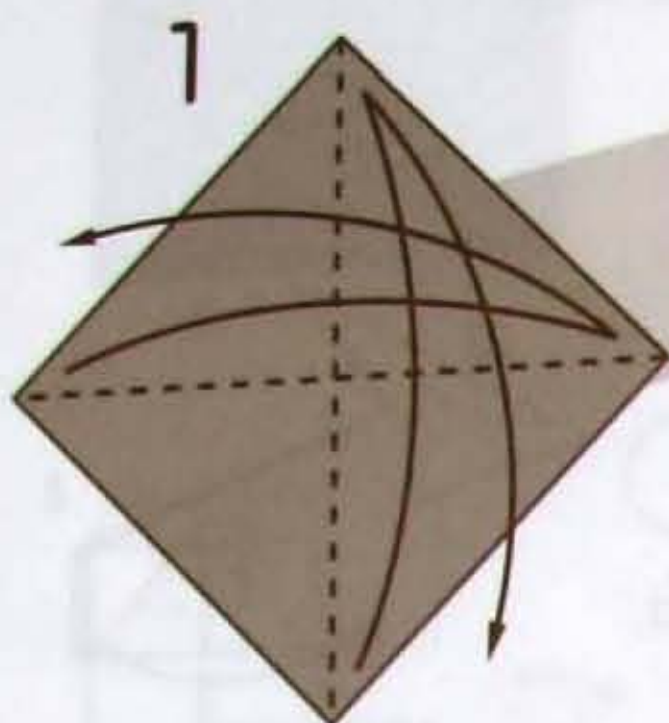
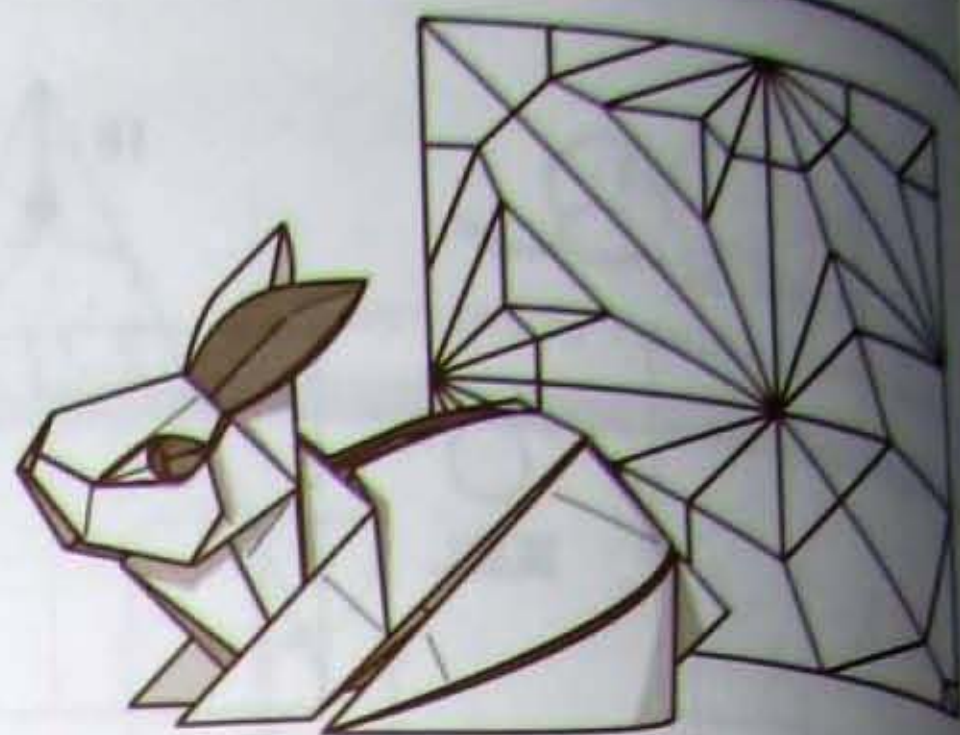

1 対角線に折り筋をつける

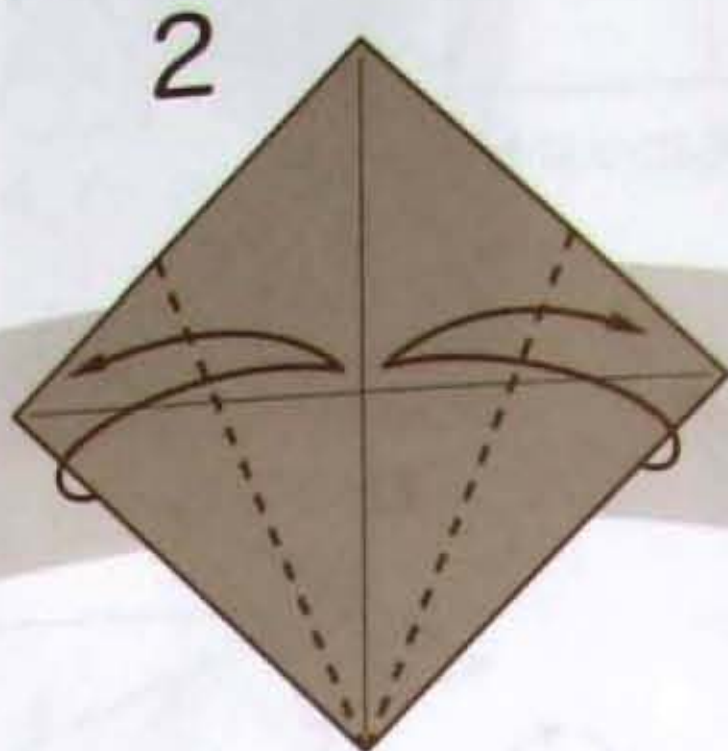

2 フチを折り筋にあわせて折り筋をつける

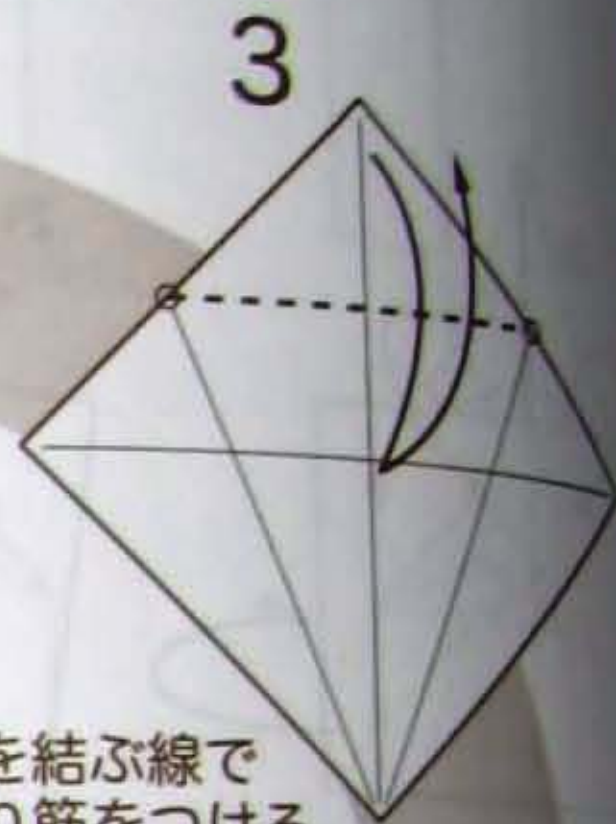

3 ○を結ぶ線で折り筋をつける

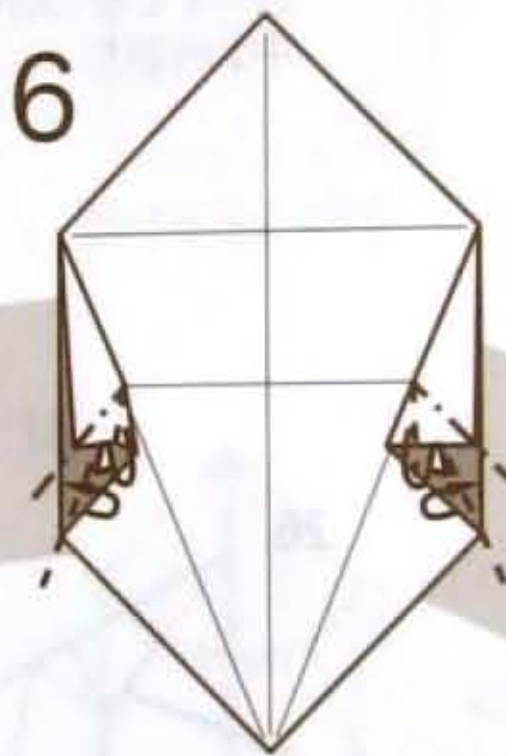

4 フチとフチをあわせてカドをつまむように折る

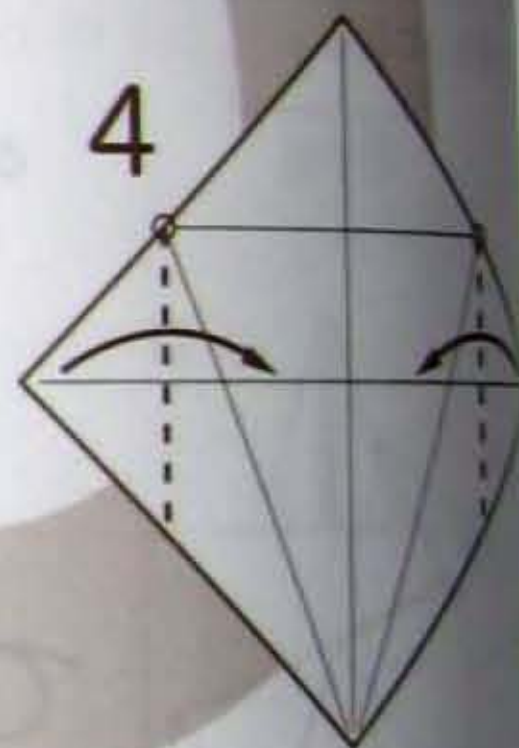

5 ○のところからカドを折り筋にあわせて折る

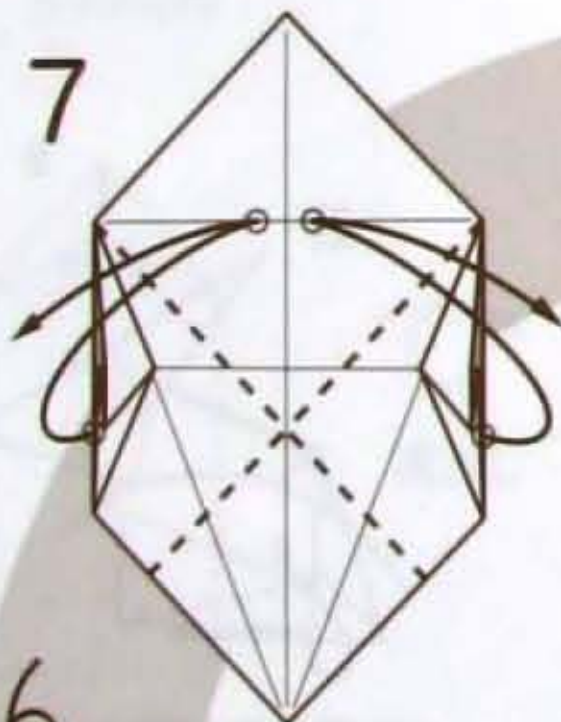

6 フチを折り筋にあわせて折り筋をつける

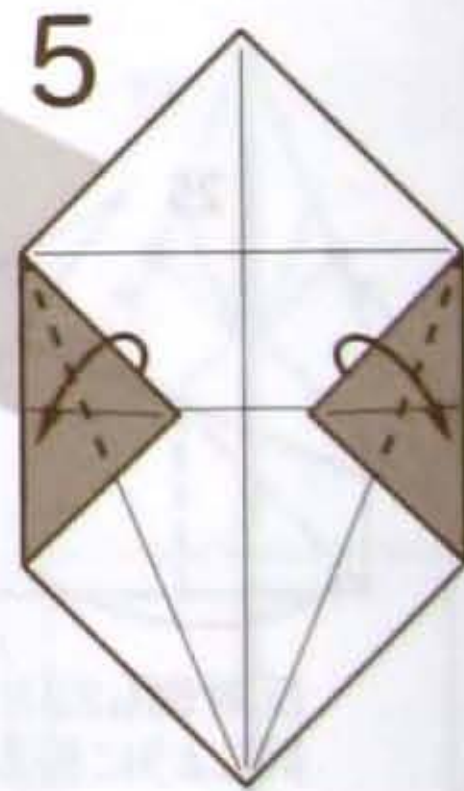

7 フチとフチをあわせて折る

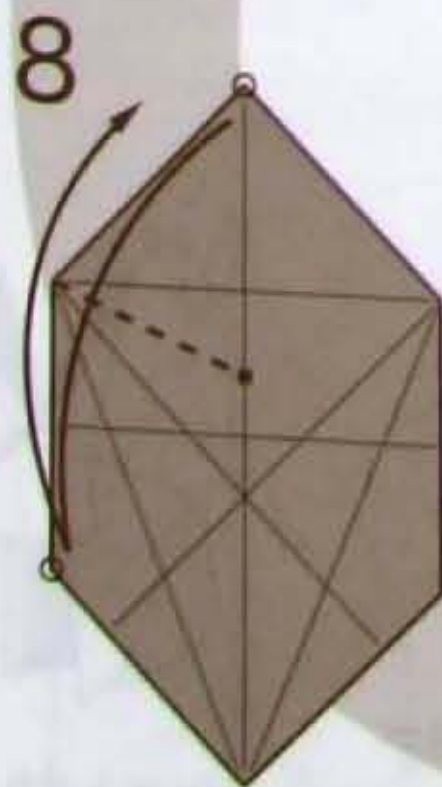

8 カドとカドをあわせて折り筋をつける

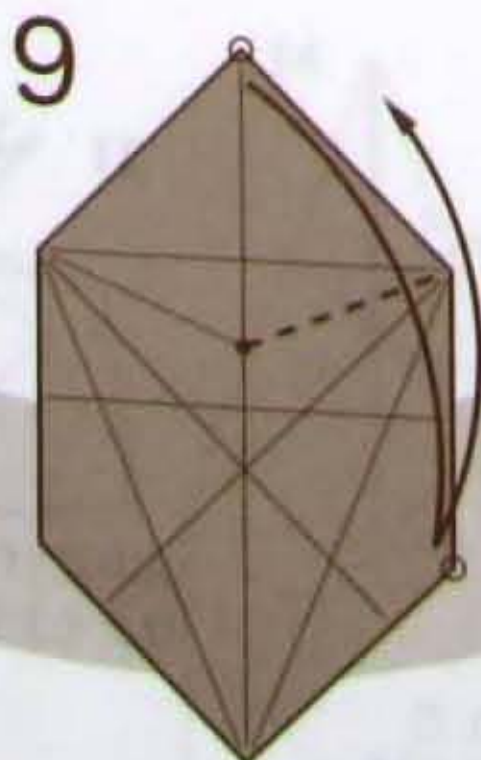

9 カドとカドをあわせて折り筋をつける

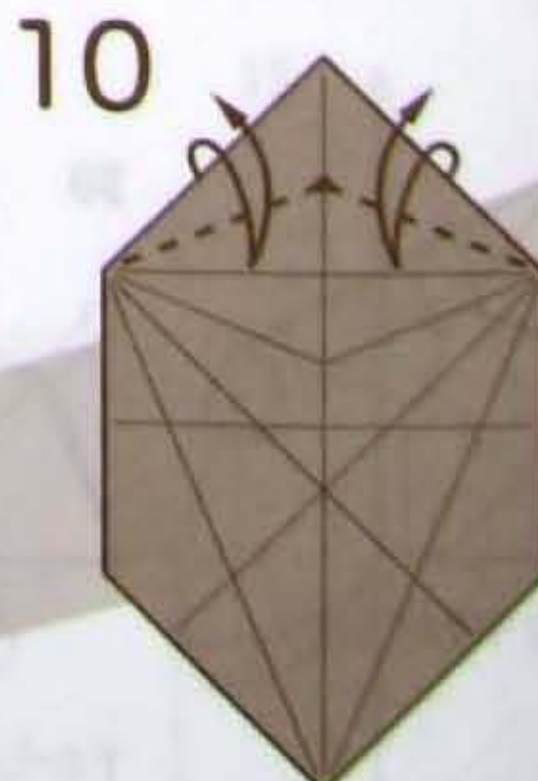

10 フチを折り筋にあわせて折り筋をつける



11 フチを折り筋にあわせて折り筋をつける



○の中を拡大

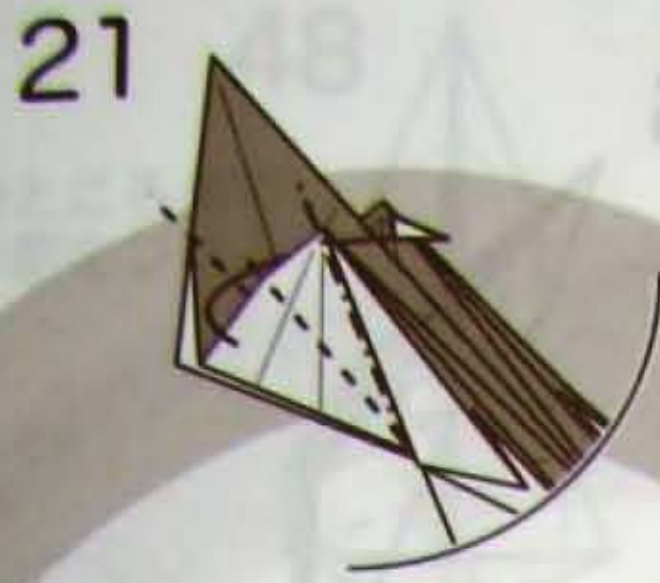

ついている折り筋で内側にずらすように折る

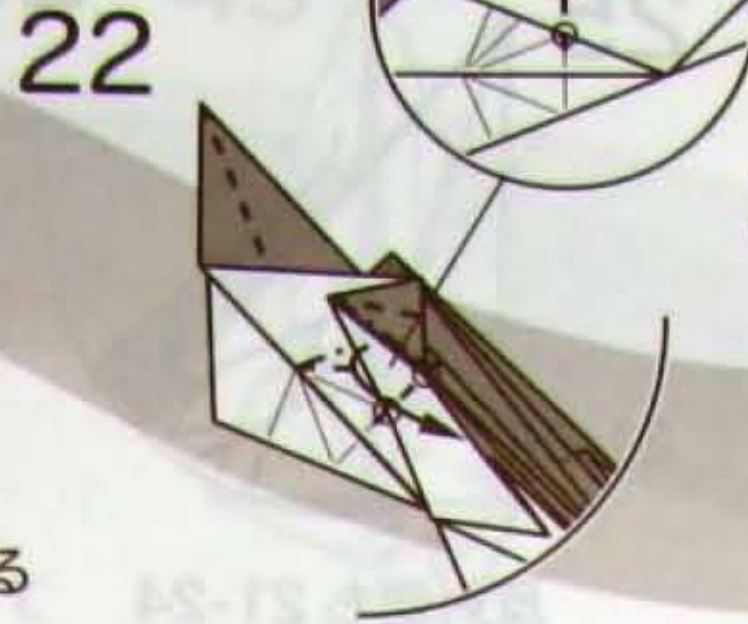

○を結ぶ線でカドを折りながら起き上がった部分を平らに折る



[途中図] 立体的になった部分を平らに折る

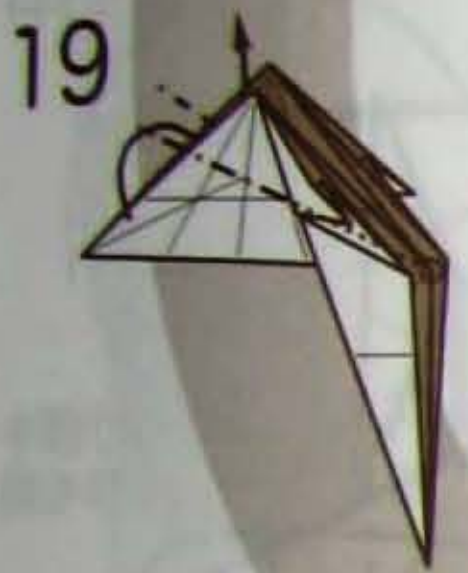

ついている折り筋で中割り折り



ついている折り筋で中割り折り

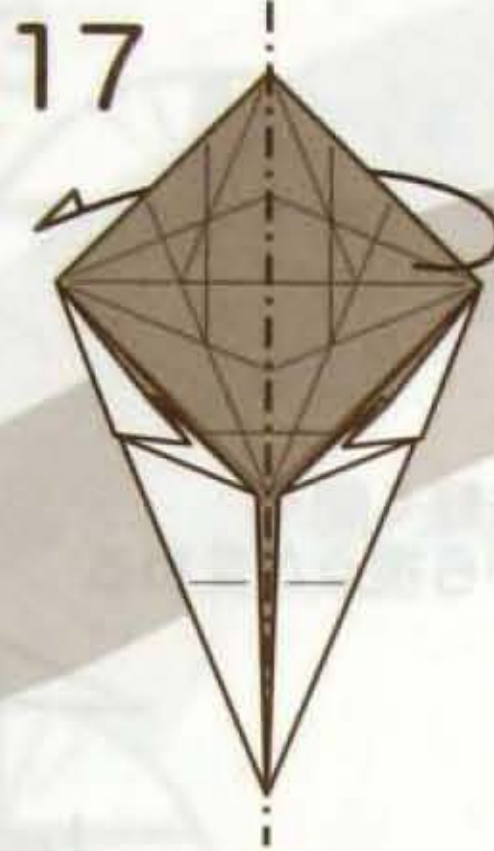

全体を半分に折る

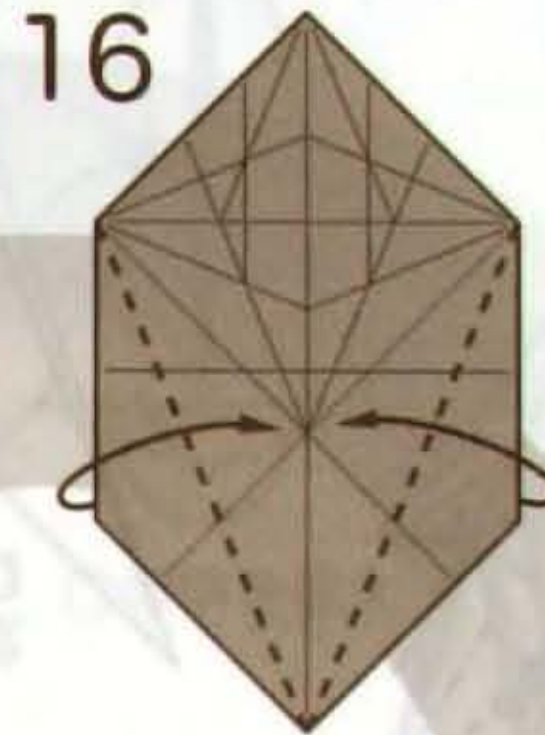

ついている折り筋で折る

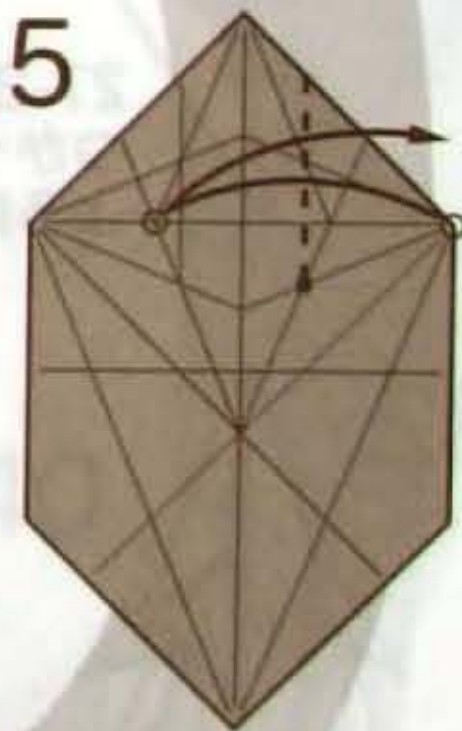

カドを折り筋の交点にあわせて折り筋をつける

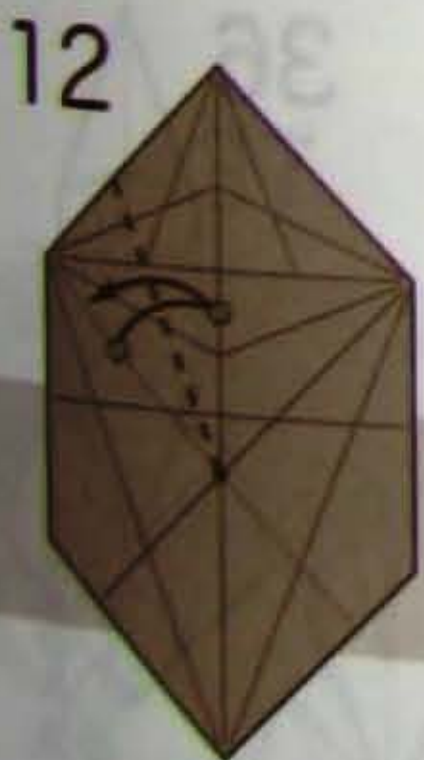

折り筋と折り筋をあわせて折り筋をつける



折り筋と折り筋をあわせて折り筋をつける

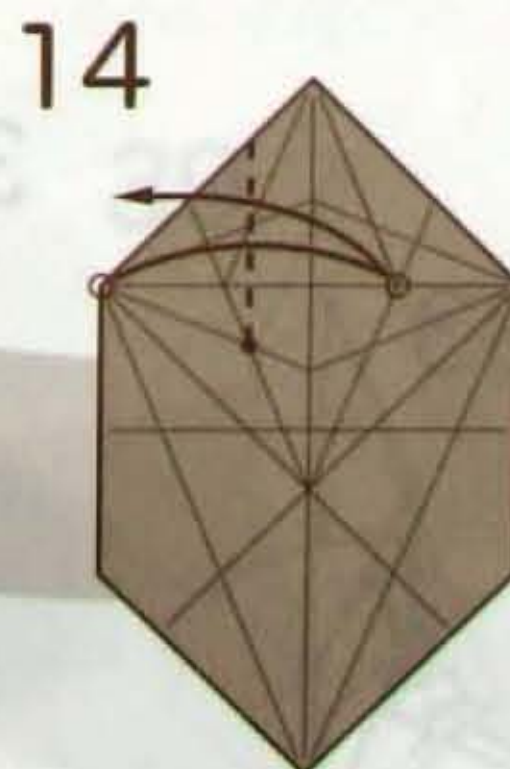

カドを折り筋の交点にあわせて折り筋をつける

24

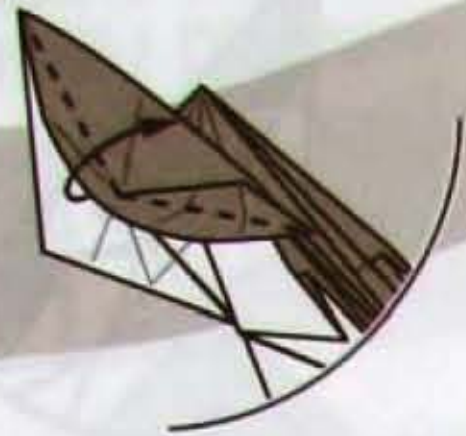

[途中図]
立体的になった
部分を平らに折る

25

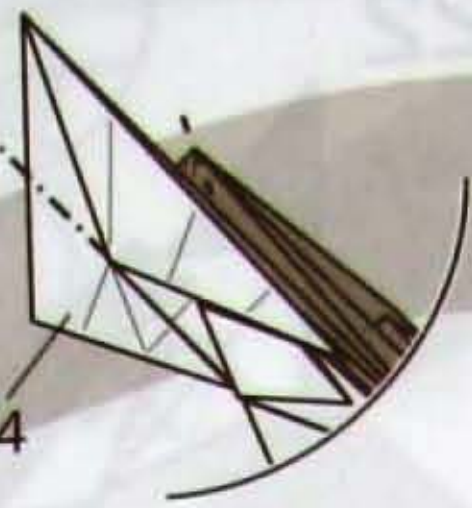

21-24

反対側も 21-24
と同様に折る

26



27



フチにそって
カドを折る

30



ひだを軽く開く
次図から視点が変わる

28



後ろのフチに
そってカドを折る

31

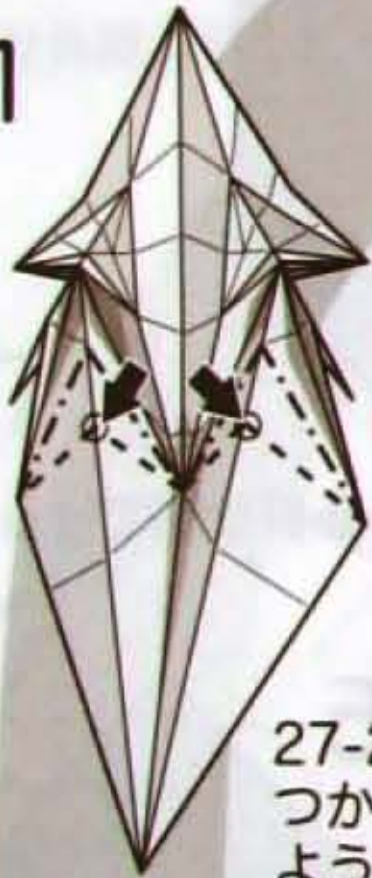

27-28 でつけた折り筋を
つかって○の部分押し込む
ように斜めに段折りする

29

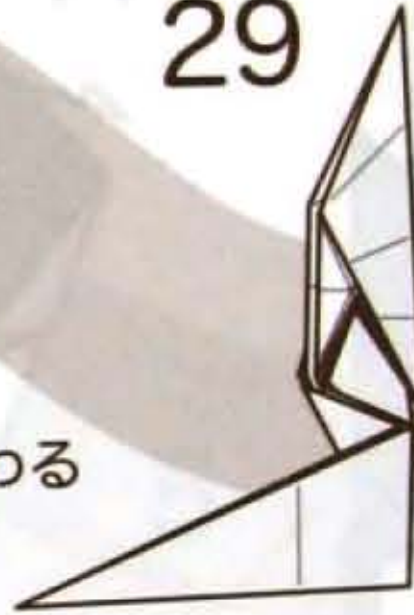

しっかり折り筋をついたら
26 の形に戻す

32



次図から視点が戻る

35

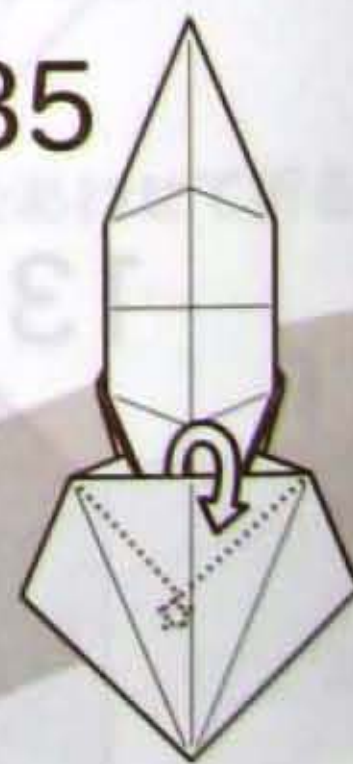

☆のカドを外に出す

36



33



真ん中から開いて
つぶすように折る

34



内側をひろげながら
つぶすように折る

48

縁のところまで
折り筋をつける



49

フチとフチをあわせて
折り筋をつける

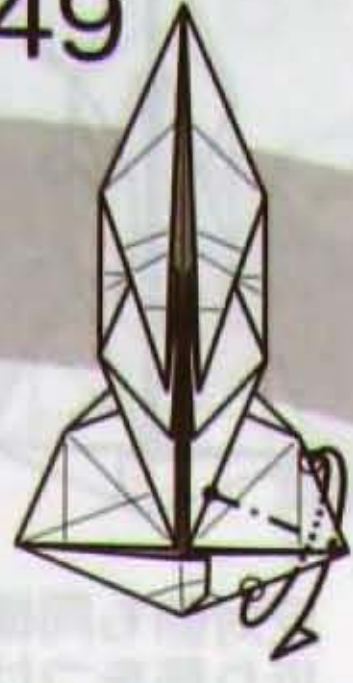

反対側も同様に
折り筋をつける

50

2つのカドを折り上げる



47

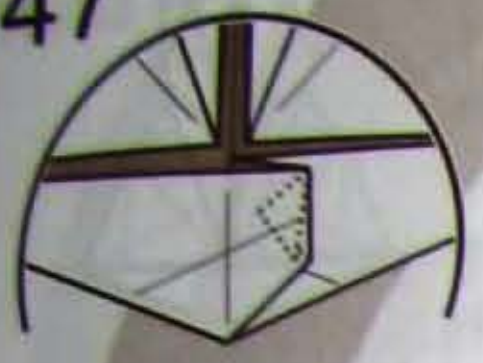

46

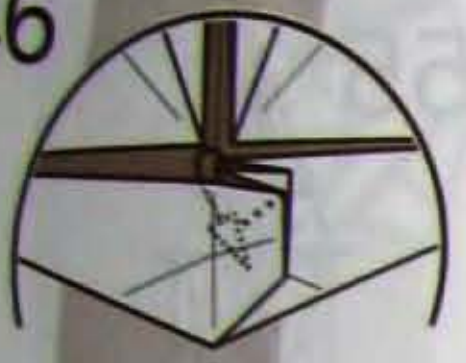

中割り折りしたカドを折って
開かないようにする

43

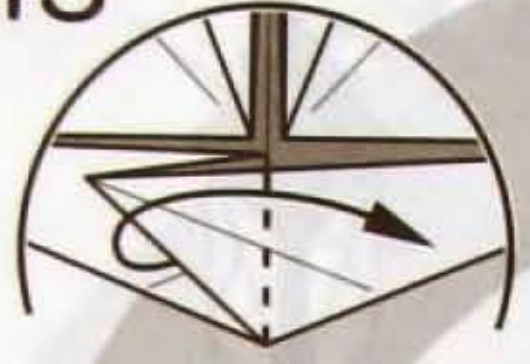

カドを反対側に折る

42

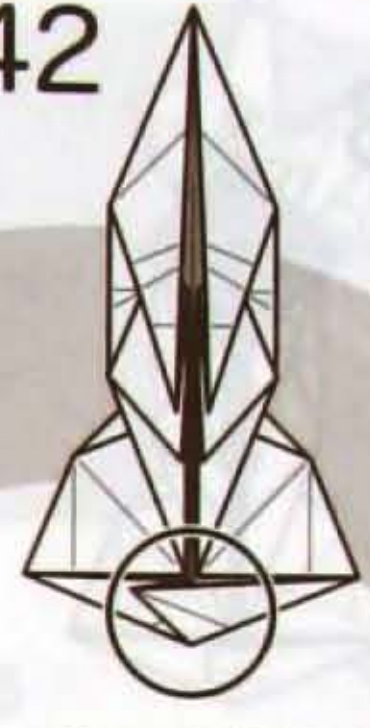

○の中を拡大

41

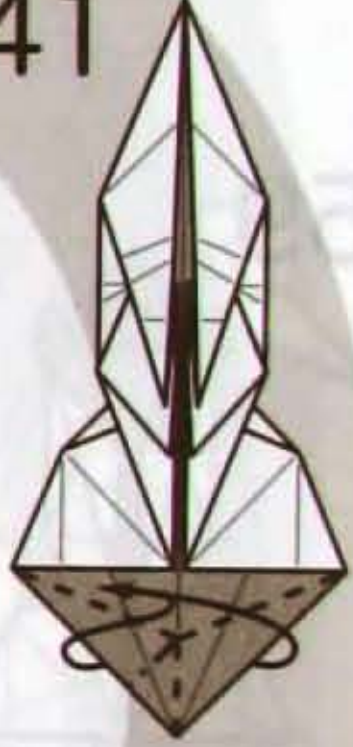

カドをつまむように折る

45

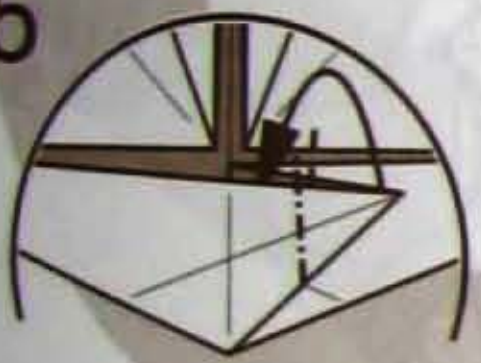

折り筋をつかって
中割り折り

44

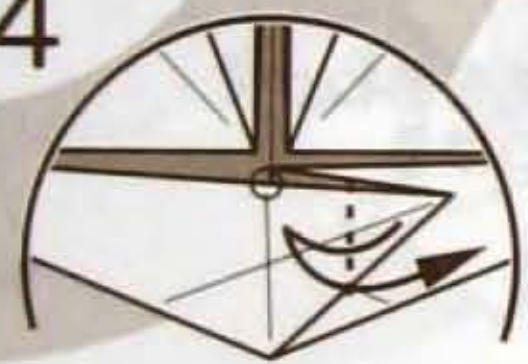

カドを折り筋にあわせて
折り筋をつける

37

真ん中まで
折り筋をつける

フチとフチ
の交点



裏側

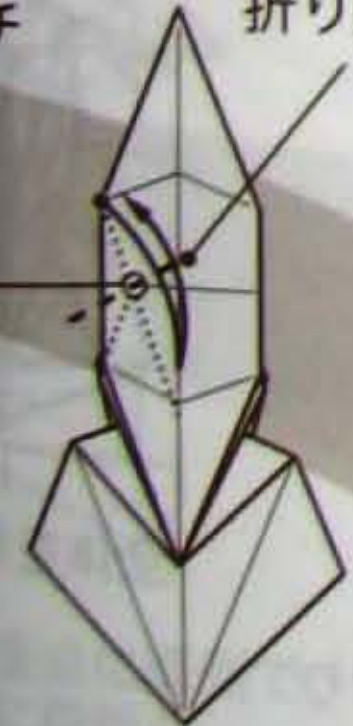

○を通るところでカド
を折り筋にあわせて
折り筋をつける

38

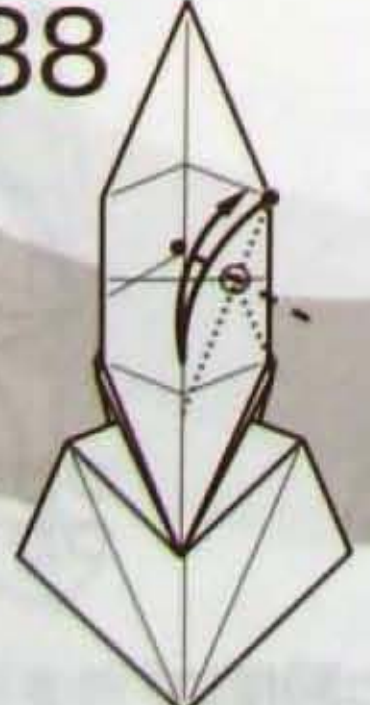

反対側も同様に
折り筋をつける

39

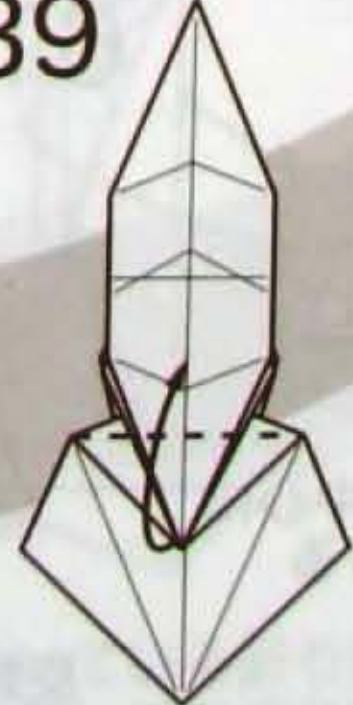

カドを折り上げる

40

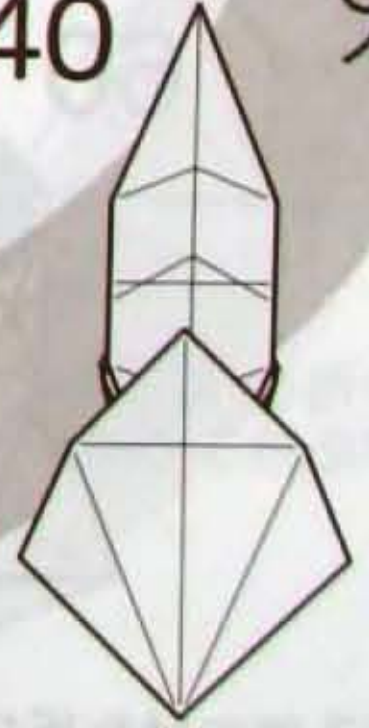

51



真ん中まで
折り筋をつける

フチとフチをあわせて
折り筋をつける

52

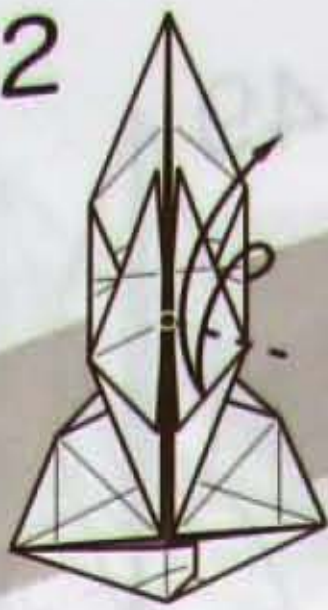

反対側も同様に
折り筋をつける

53

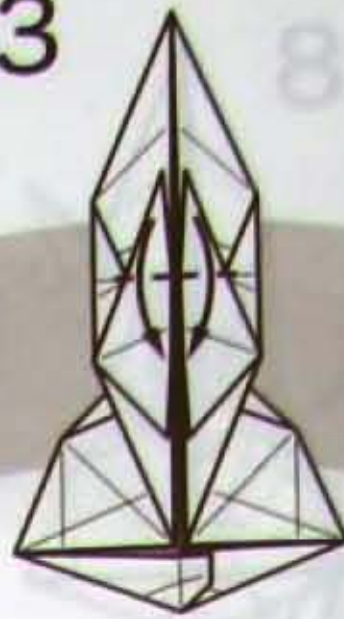

2つのカドを折り下げる

54



カドを折り筋にあわせて
折り筋をつける

58

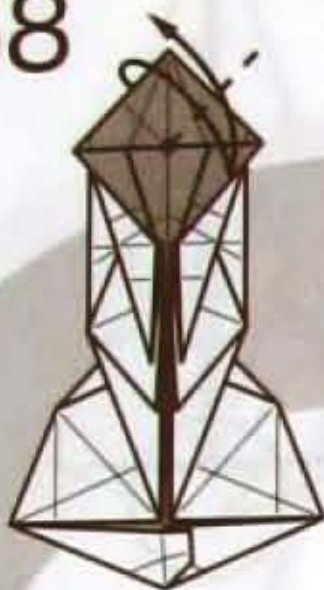

同様に折り筋をつける

57



フチのところまで
折り筋をつける

フチとフチをあわせて
折り筋をつける

55

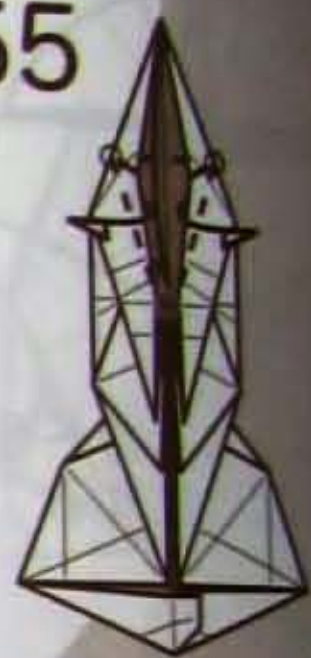

○を結ぶ線で内側を
ひろげるように折る

59



フチにそってカドを折る

56



○のカドを結ぶ線で折る

60



フチのところまで
折り筋をつける

57 でつけた折り筋を中心
にあわせて折り筋をつける

62



つけた折り筋を
つかってつまみ折り

63



全体を半分に折る

61



反対側も 60 と同様に
折り筋をつける

74



反対側も 70-73
と同様に折る

75



カドを中割り折り

76

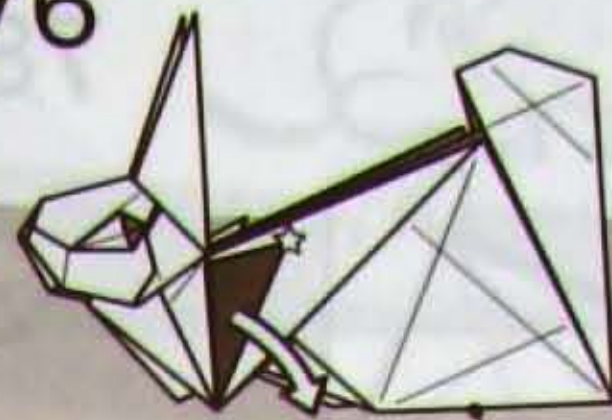

■のカドを
引っ張り出す

この縁と☆のカドが
重なるところまでずらす

73



フチにそって内側に
ずらすようにに折る

70



○を結ぶ線で折る

69

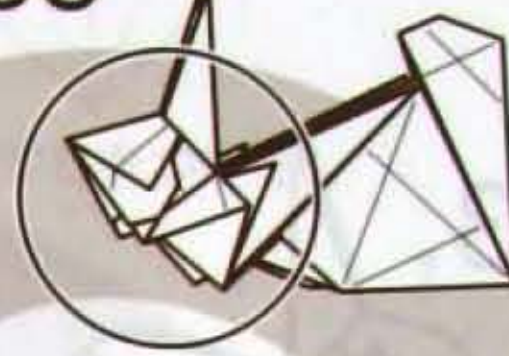

112.5°

72



○を結ぶ線でカド
を後ろに折る

71

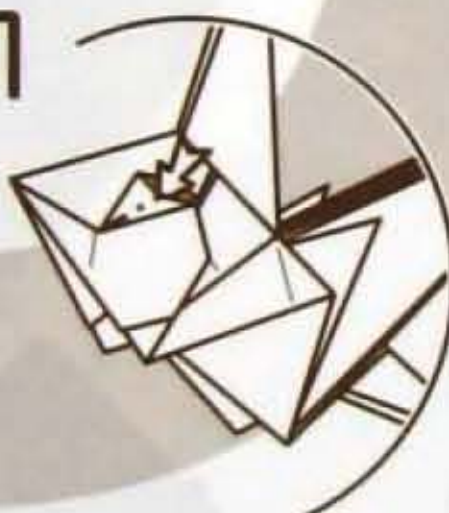

内側をひろげて
つぶすように折る

68

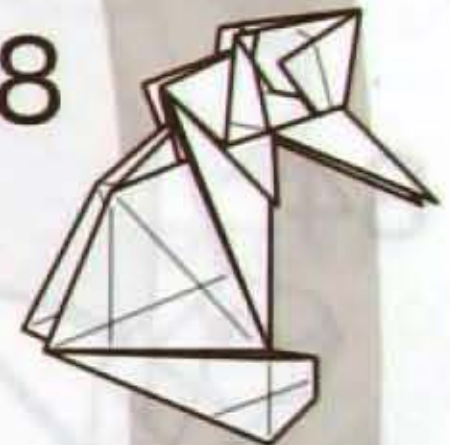

64

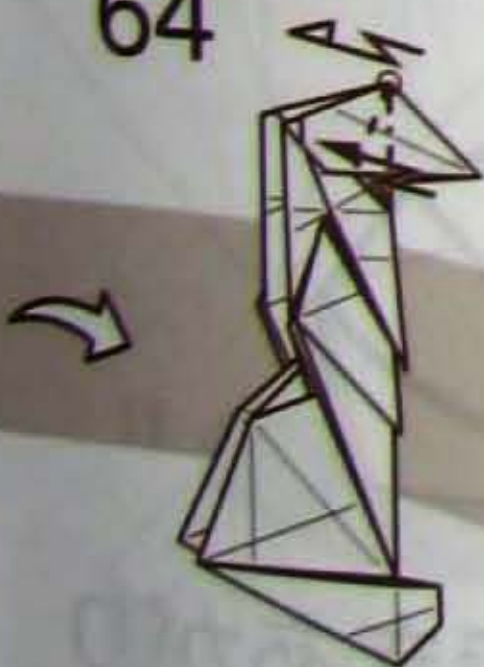

○を支点に両側で
斜めに段折り

65



2つのカドを折り上げる

66



ついている折り筋を
つかってかぶせ折り

67



ついている折り筋を
つかってかぶせ折り

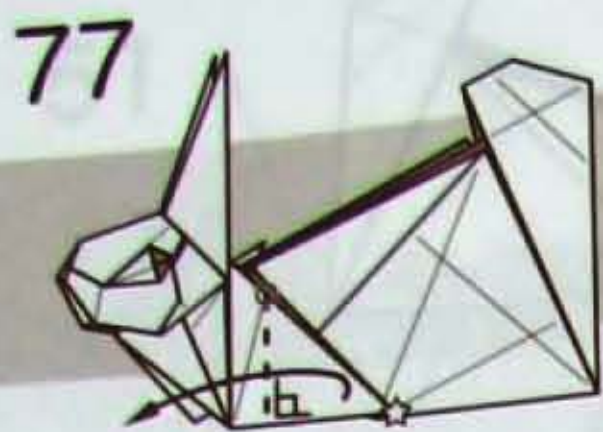

○のところから
辺に垂直に折る

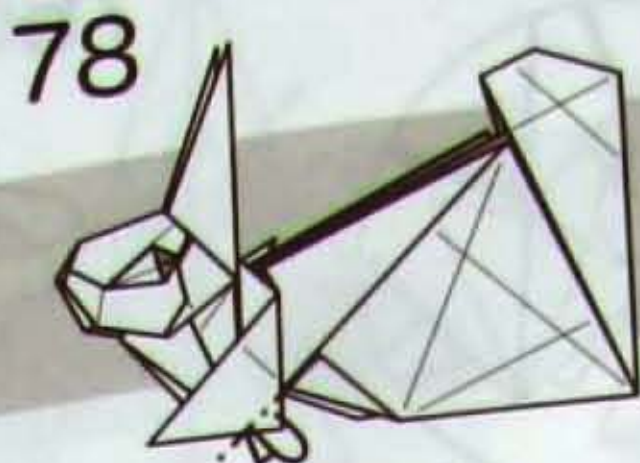

カドを折って後ろの
隙間に差し込む

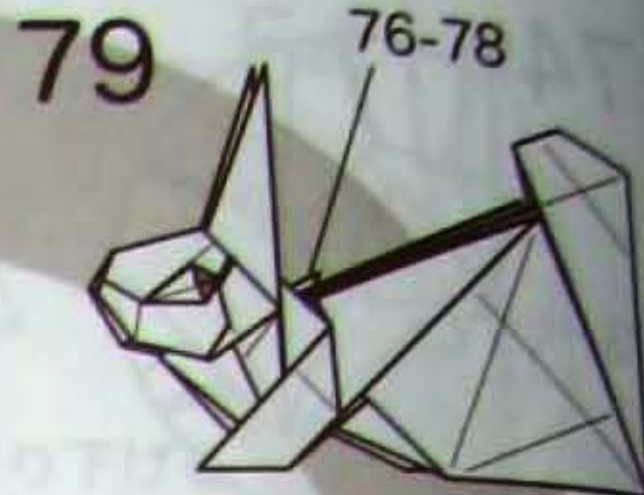

反対側も 76-78
と同様に折る



反対側も同様に
折って留める



カドを折って開き留めする



○を支点にして
両側で斜めに段折り
立体的になる



○を支点にして
両側で斜めに段折り



次図は波線の内側の透視図



2つ目の隙間で耳を開く



目を丸く開く



できあがり

ねこ Cat

川畑文昭 2011年2月28日
February 28, 2011
Kawahata Fumiaki



Copyright By Fumiaki Kawahata 2011

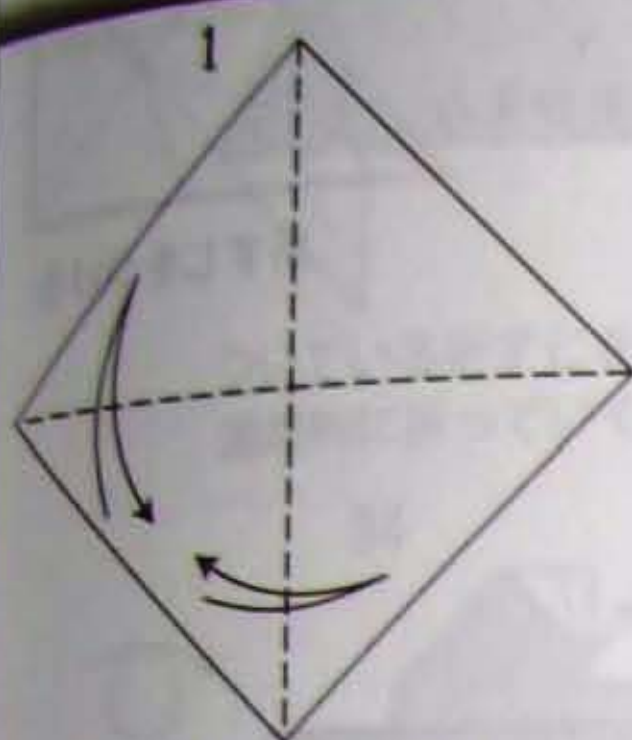

1 折すじをつける

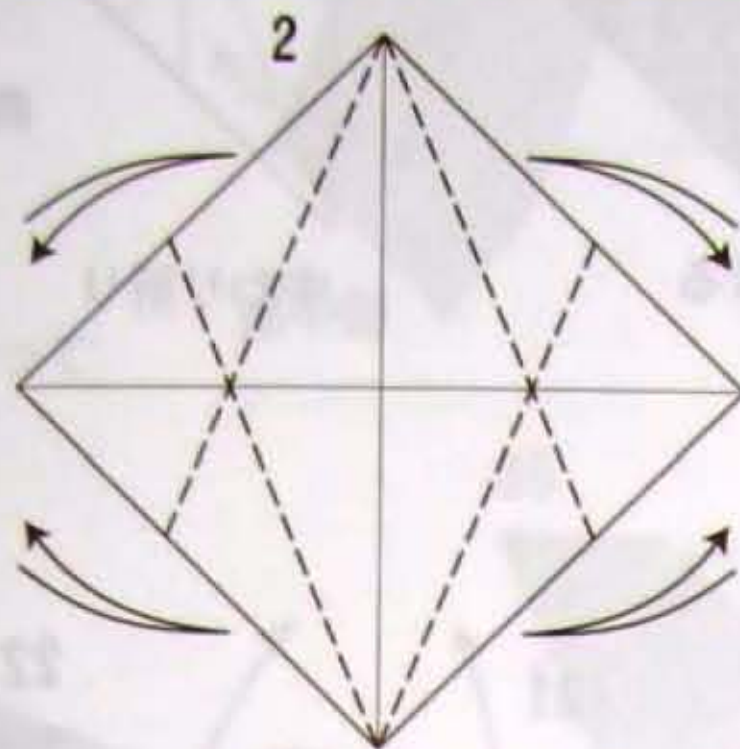

2 折すじをつける

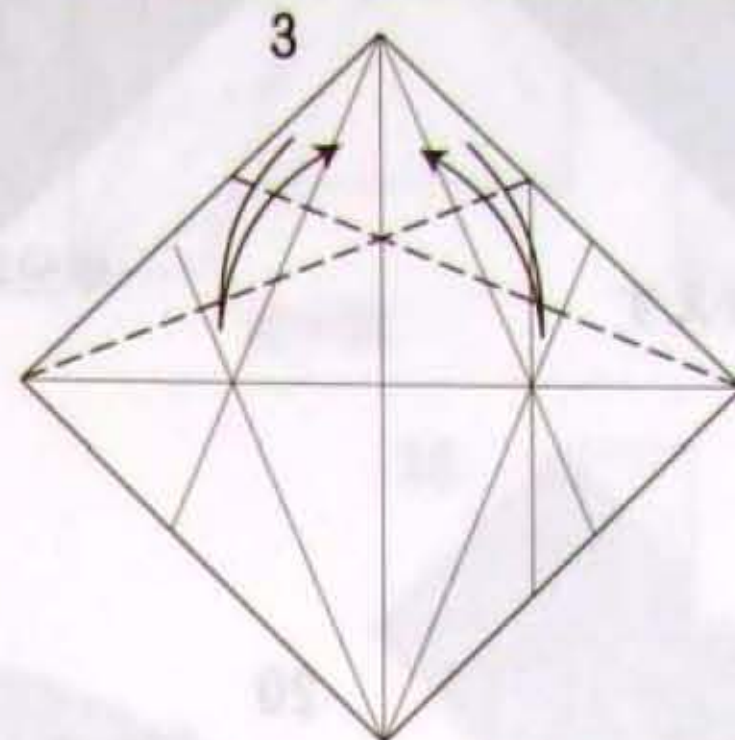

3 折すじをつける

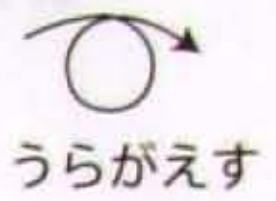

うらがえす

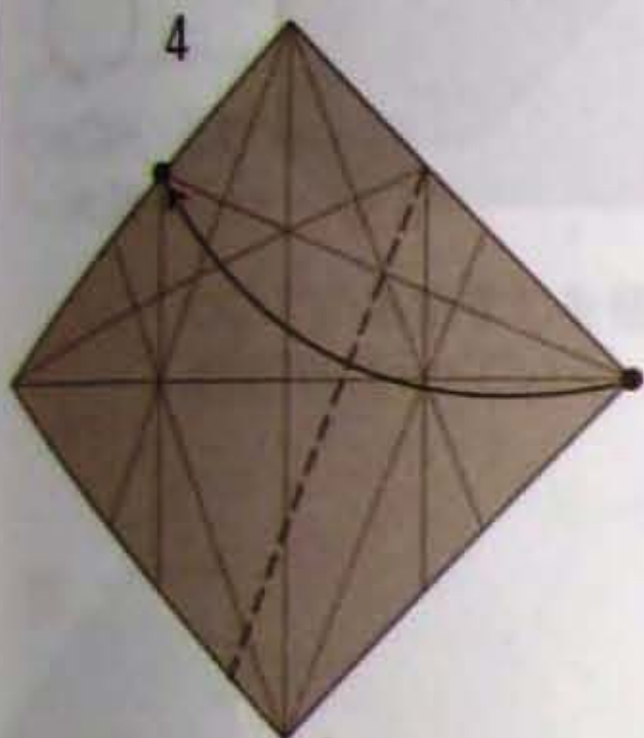

4 ●をあわせて折る

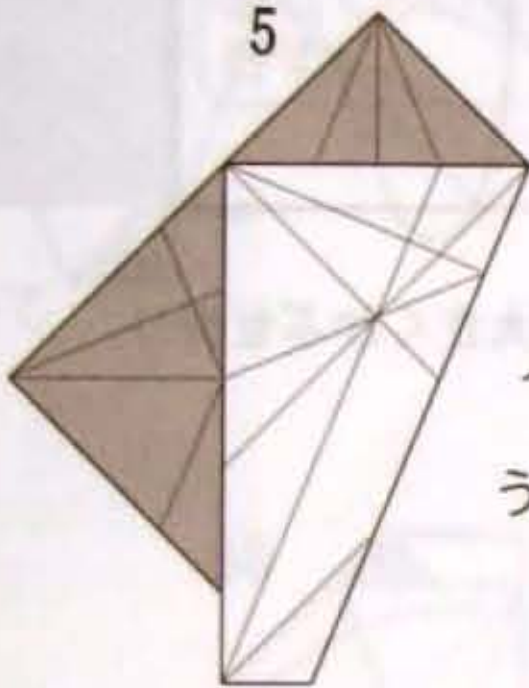

うらがえす

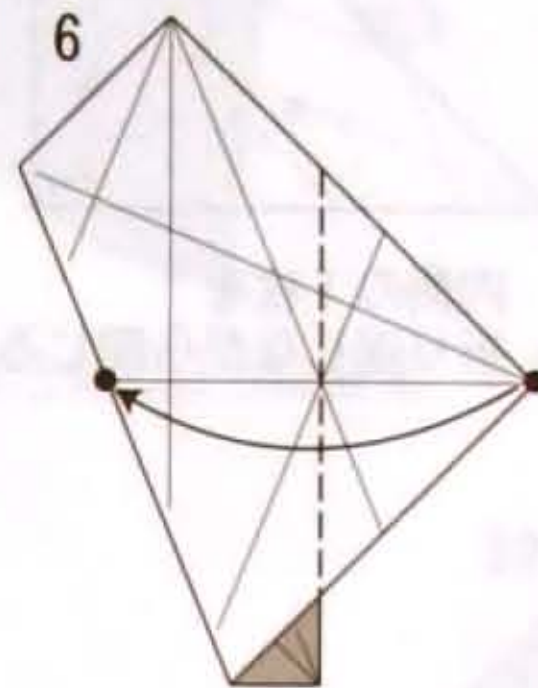

6 ●をあわせて折る

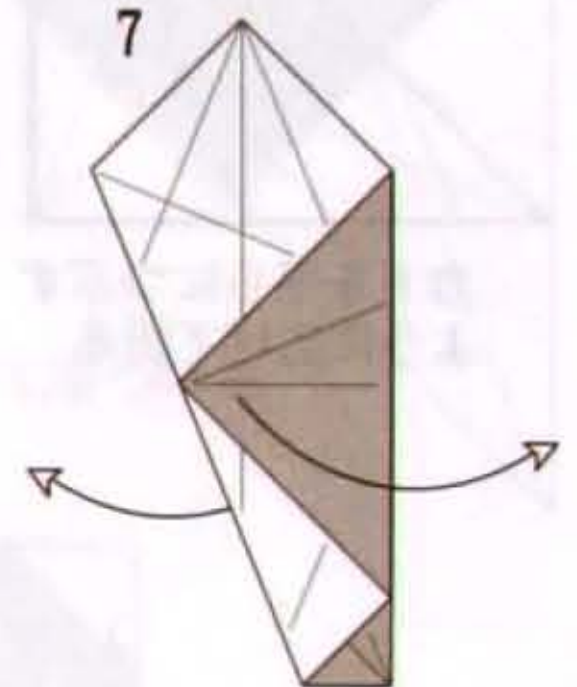

7 広げて戻す

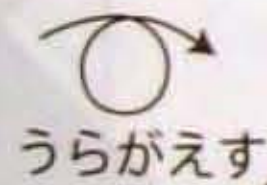
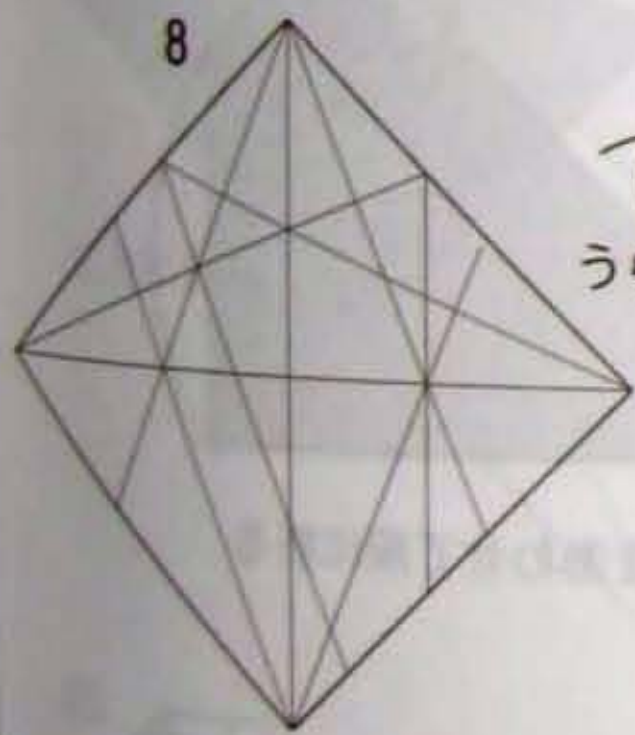

うらがえす

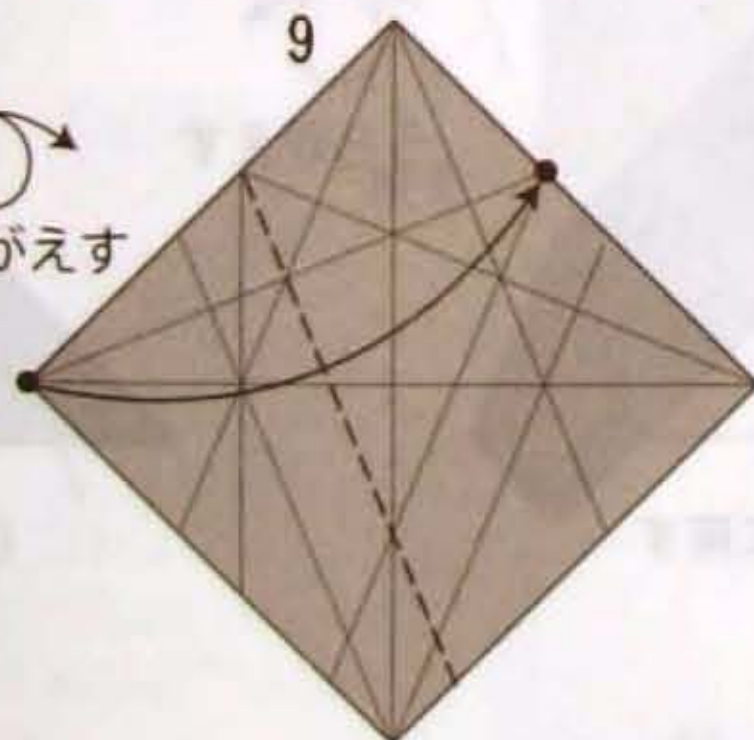

9 ●をあわせて折る

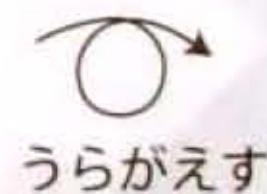
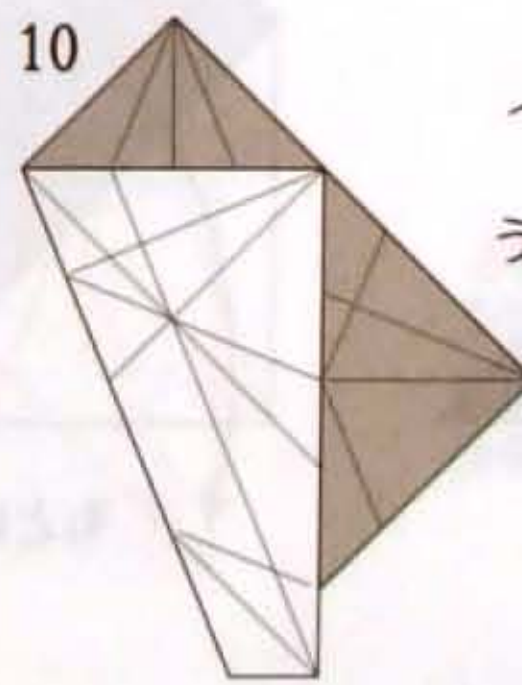

うらがえす

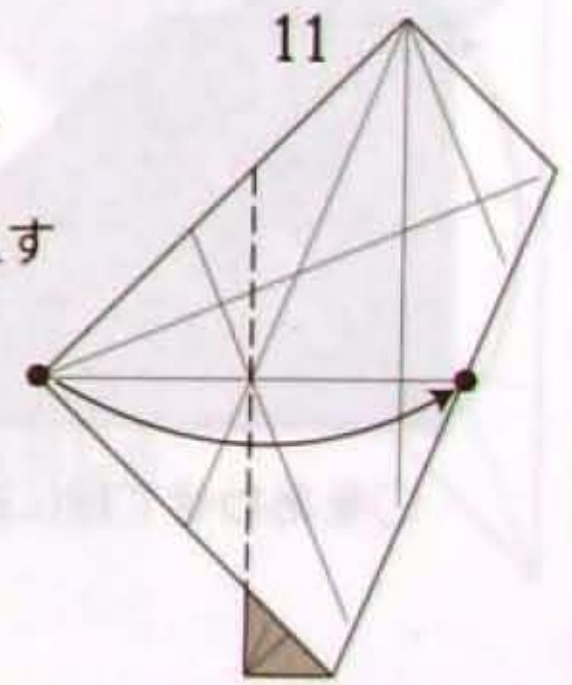

11 ●をあわせて折る

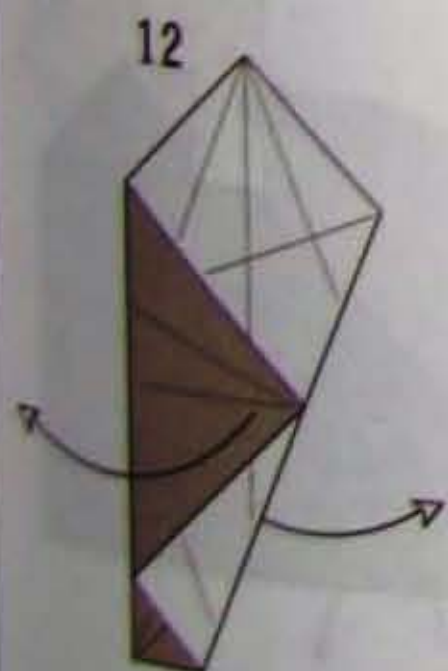

12 広げて戻す

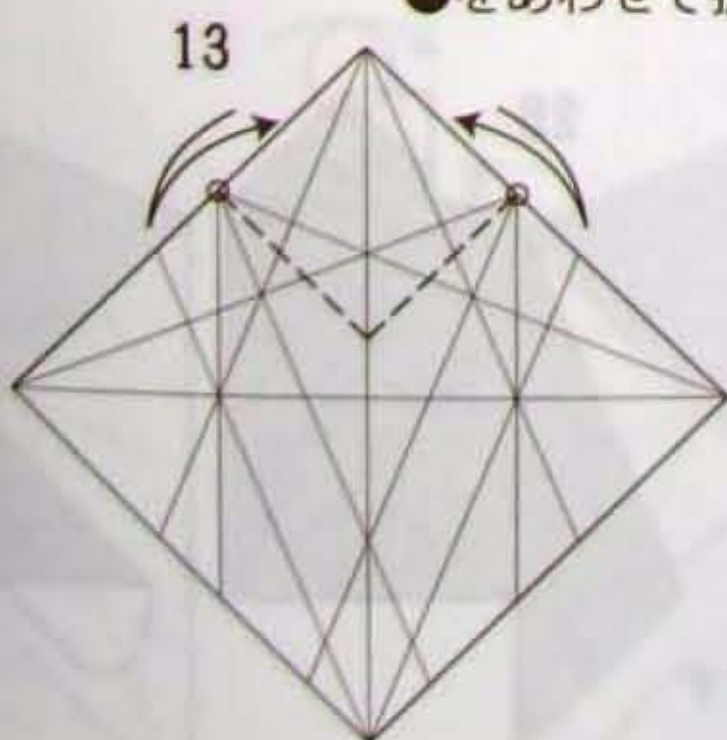

13 折すじをつける

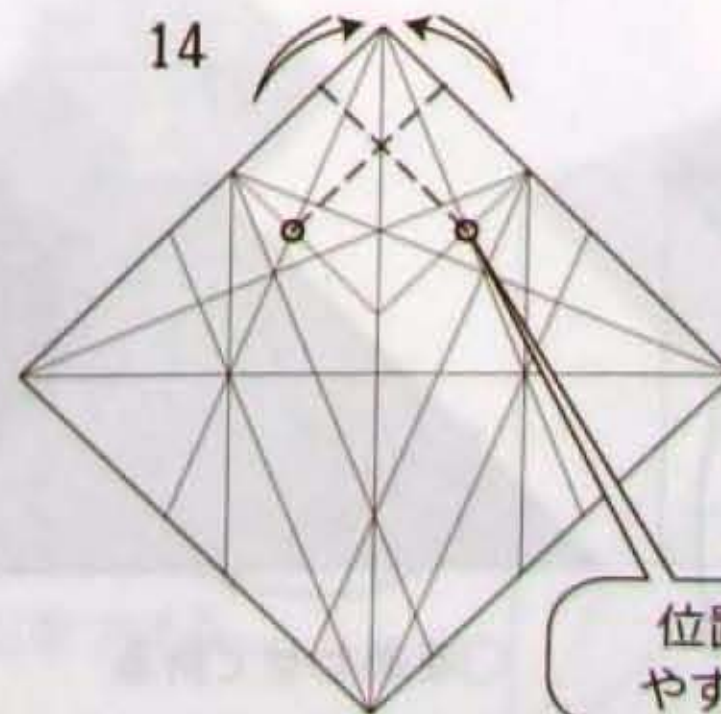

14 折すじをつける

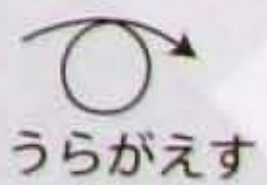

うらがえす

位置を間違え
やすいので注意

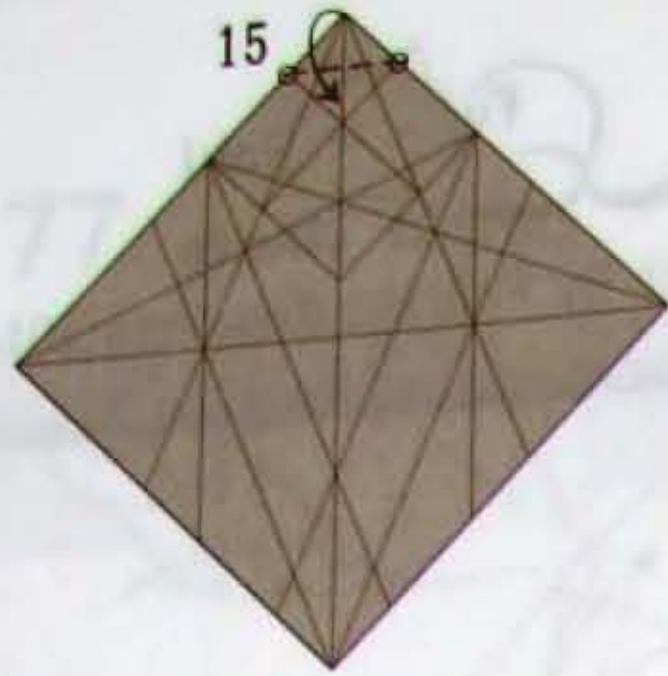

15 折りかえす

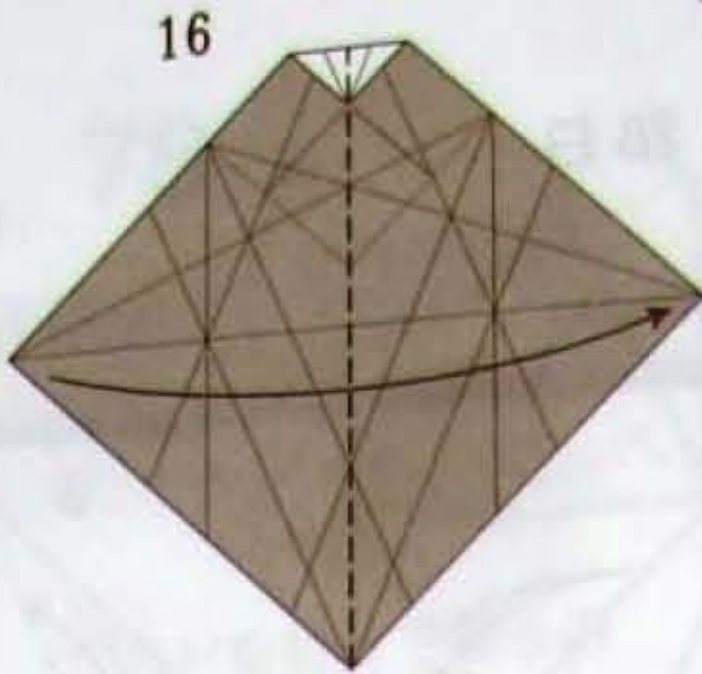

16 半分に折る

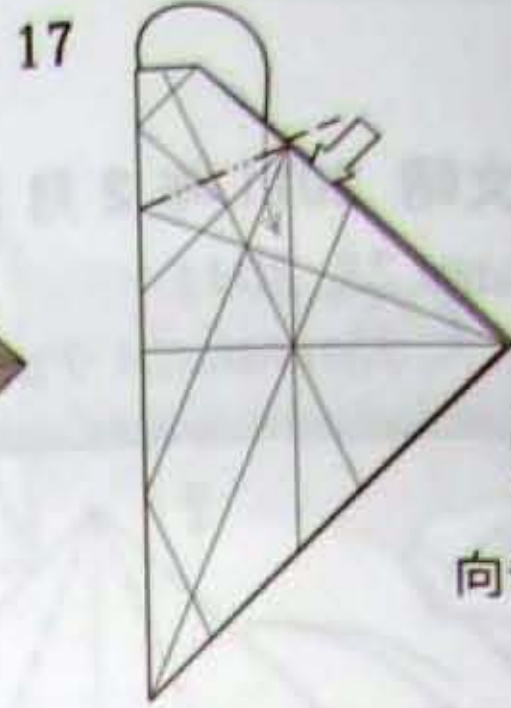

17 中わり折り

向きをかえる

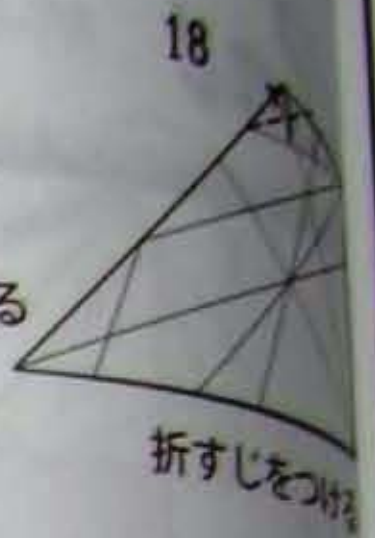

18 折すじをつける

新しくつけ
折すじ

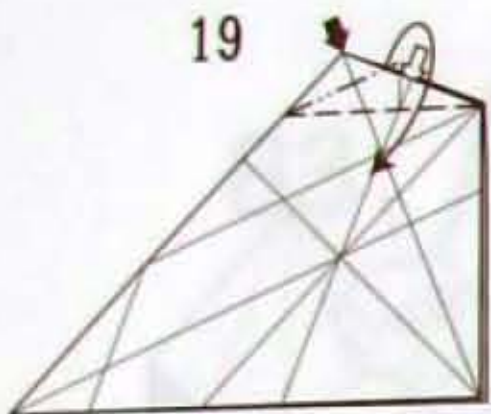

19 カドを平らにつぶす
ように広げて折る

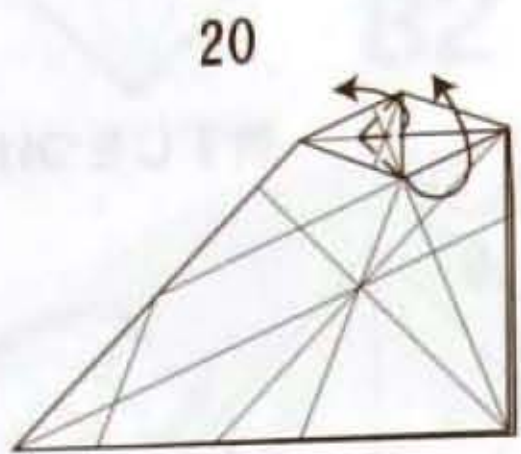

20 内側の1枚を
折り返しながら閉じる

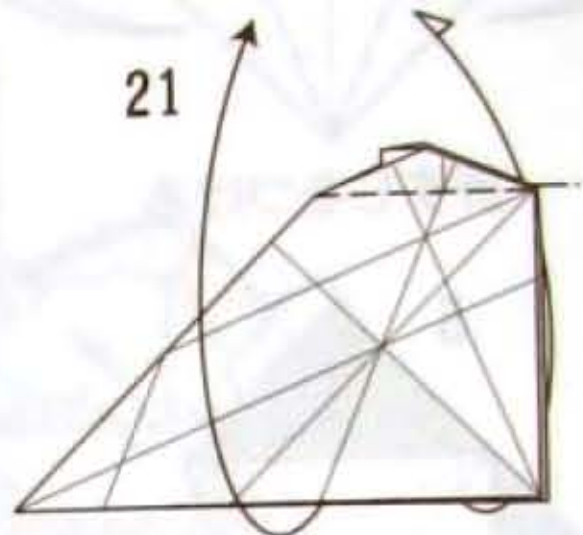

21 全体を大きくかぶせ折り

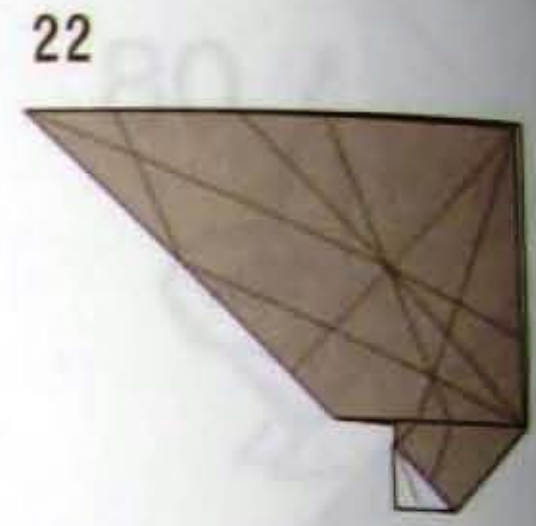

上下
うらが
ついで
拡大

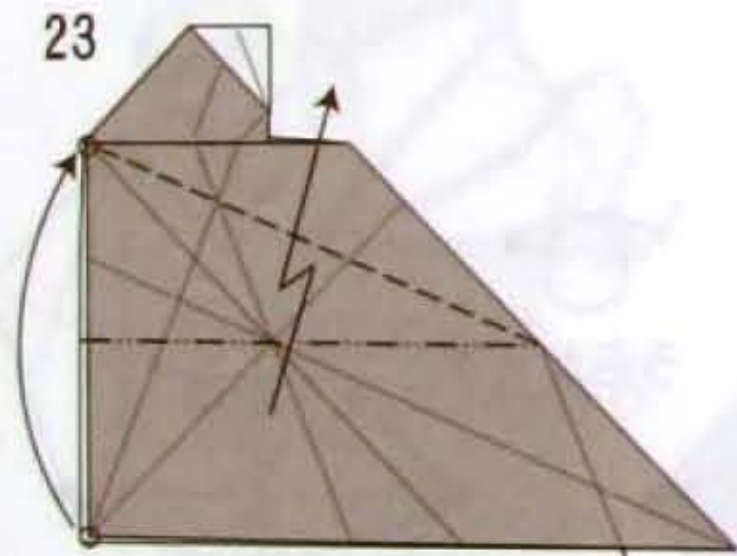

23 ○をあわせて段に折る

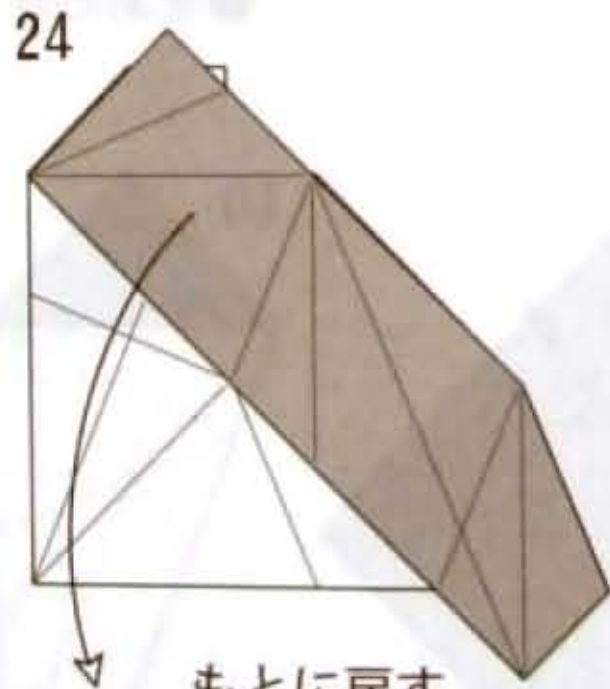

24 もとに戻す

うらがえす

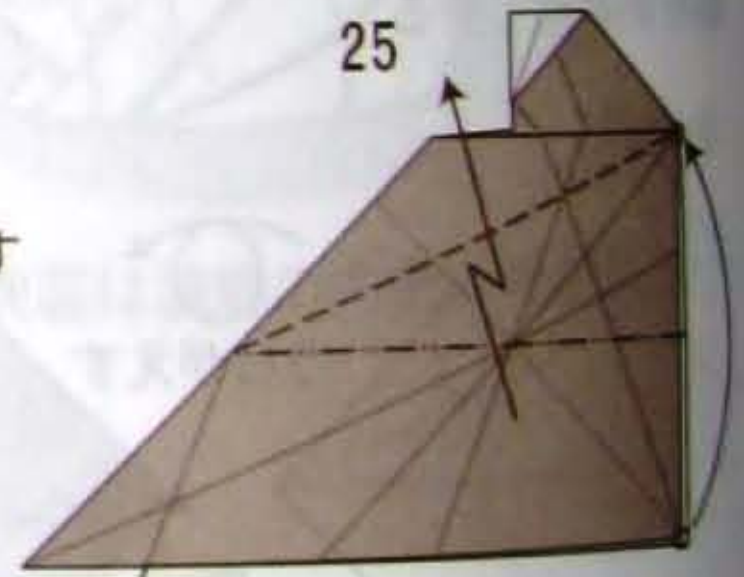

25 ○をあわせて段に折る

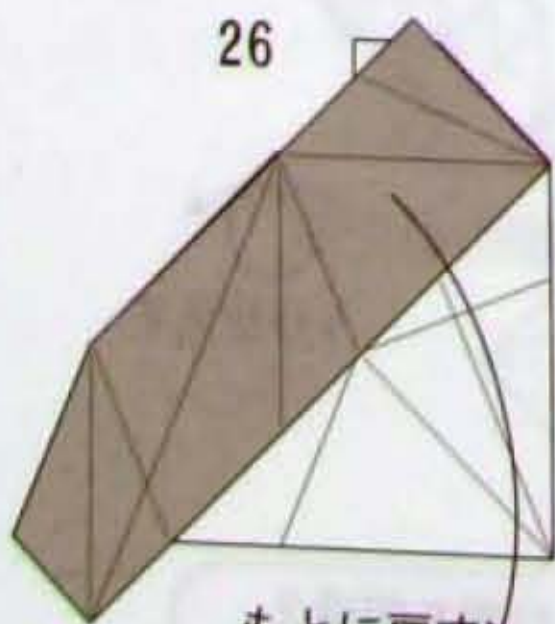

26 もとに戻す

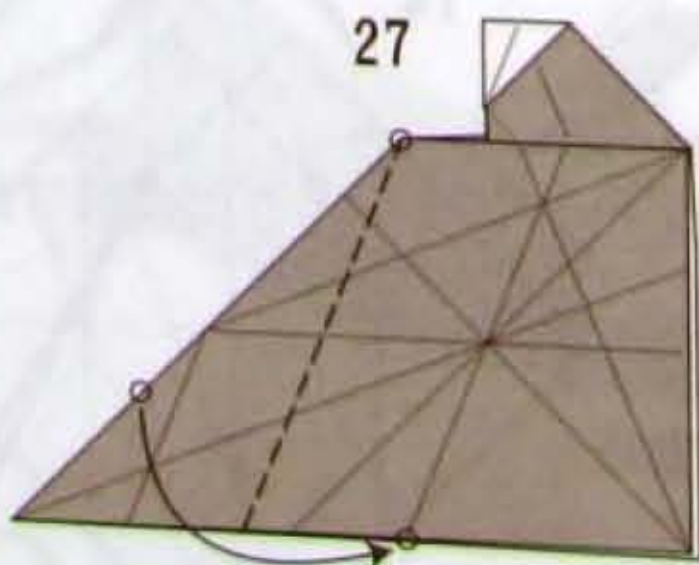

27 ○をあわせて折る

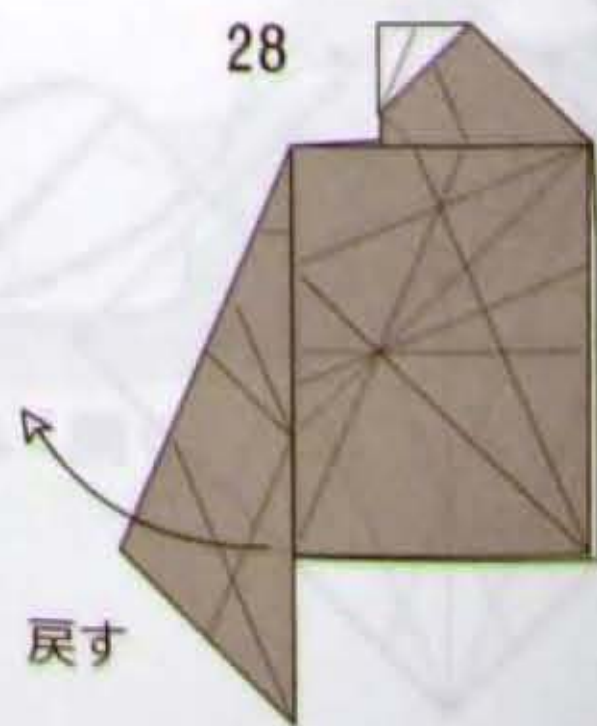

28 戻す



29 中わり折り

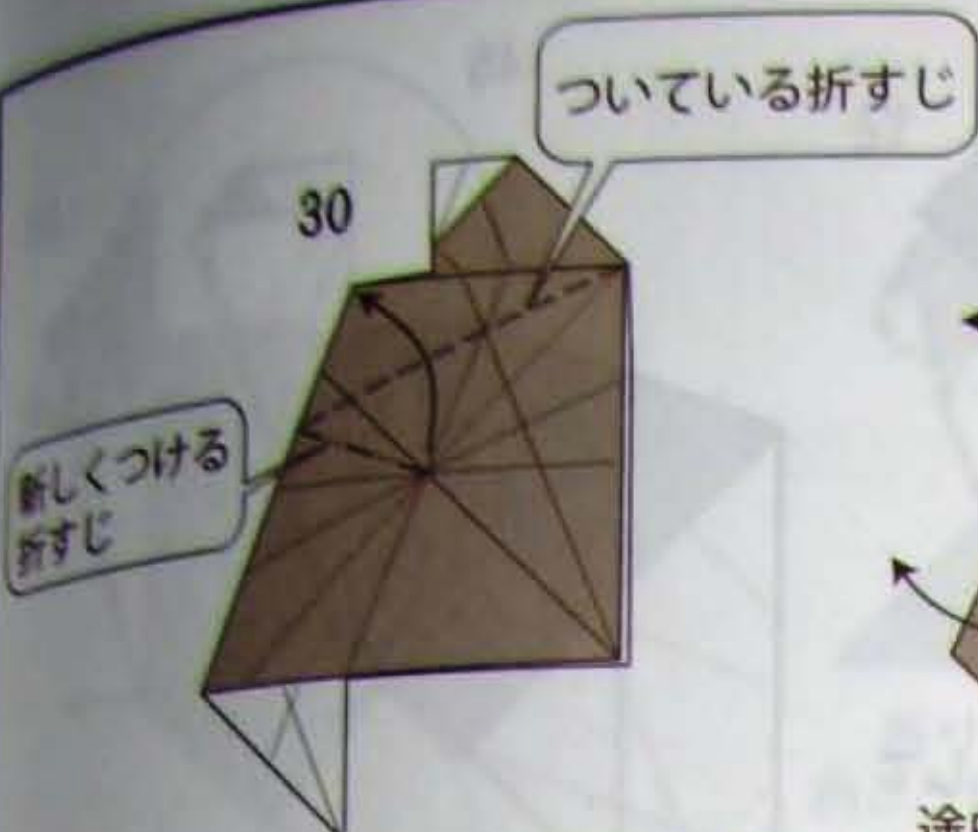

ついでに折すじを使って連続的に折っていく

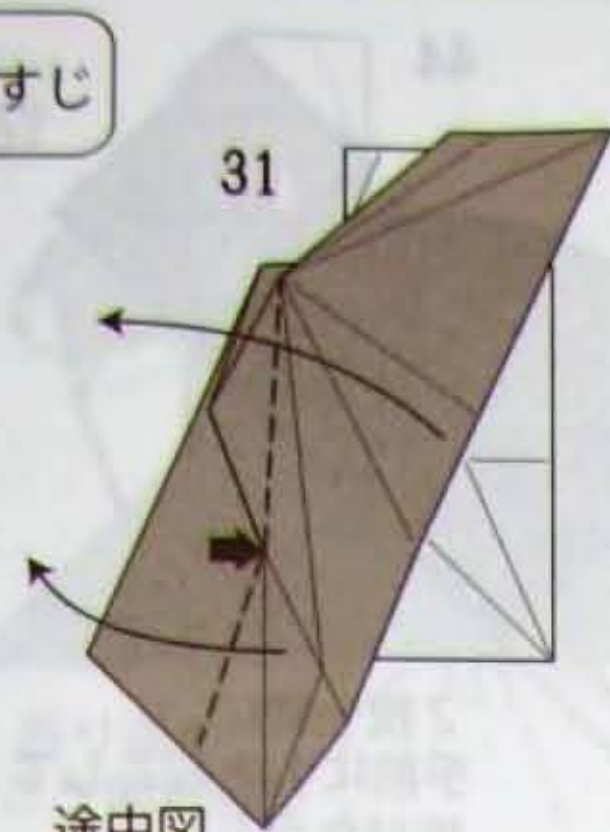

途中図

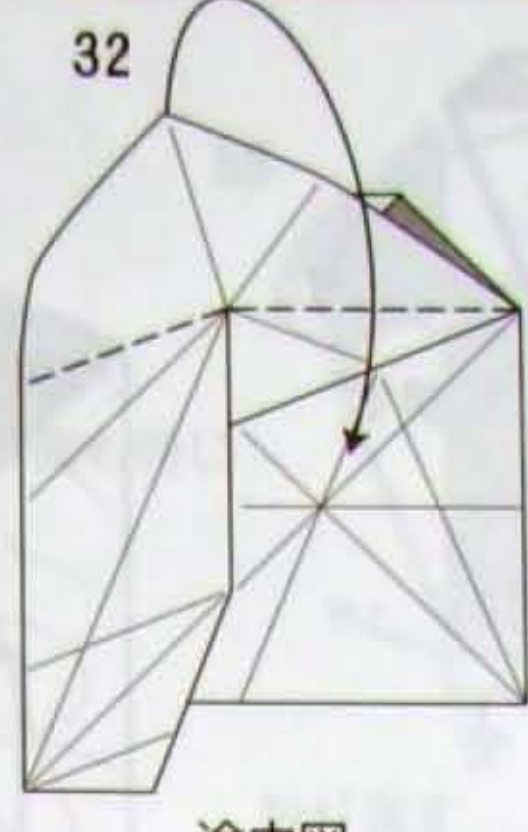

途中図

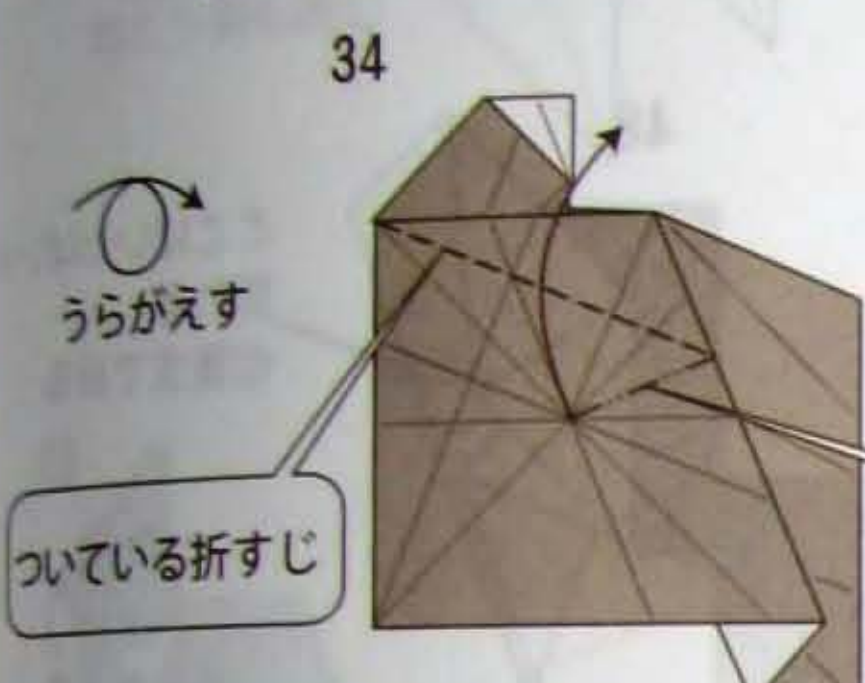
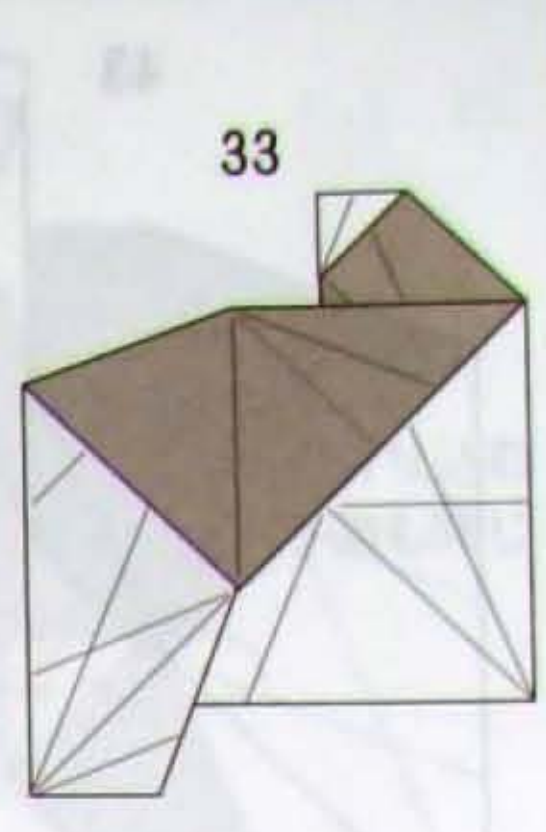

ついでに折すじを使って連続的に折っていく

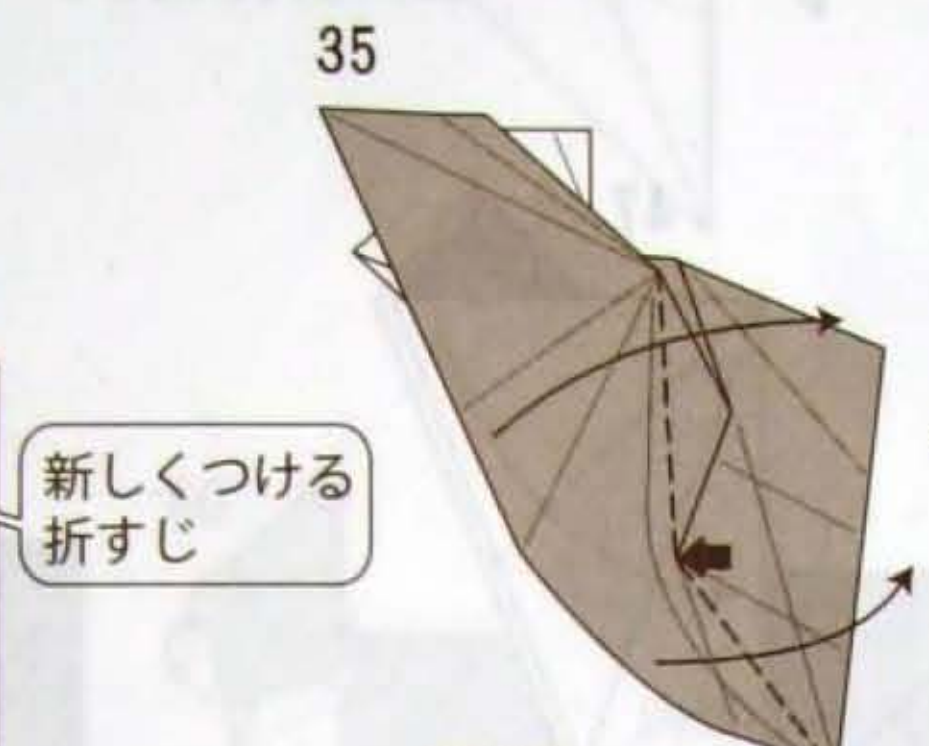

途中図

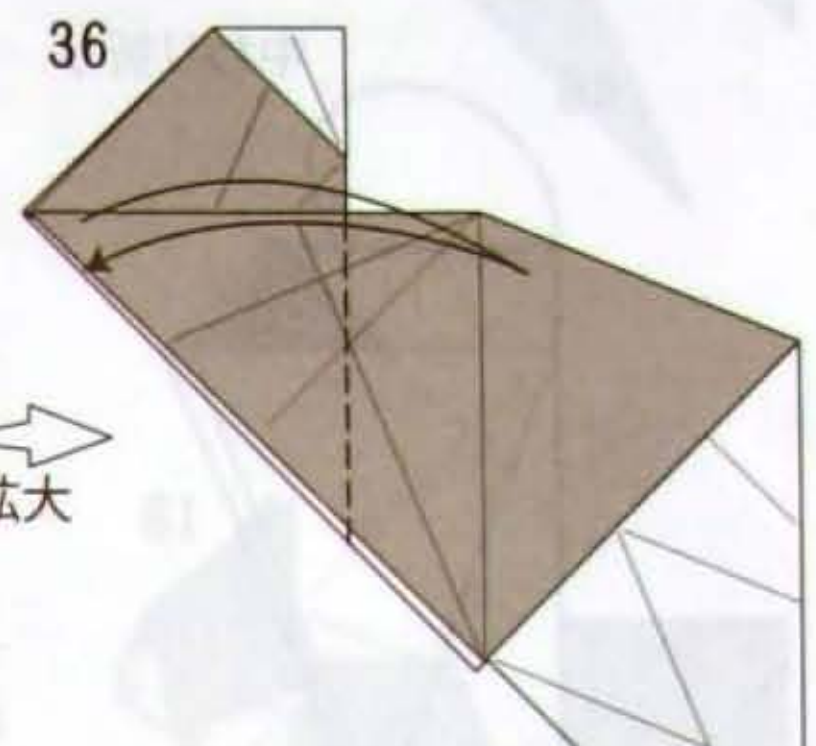

折すじをつける

31 ~ 32 と同じように折る

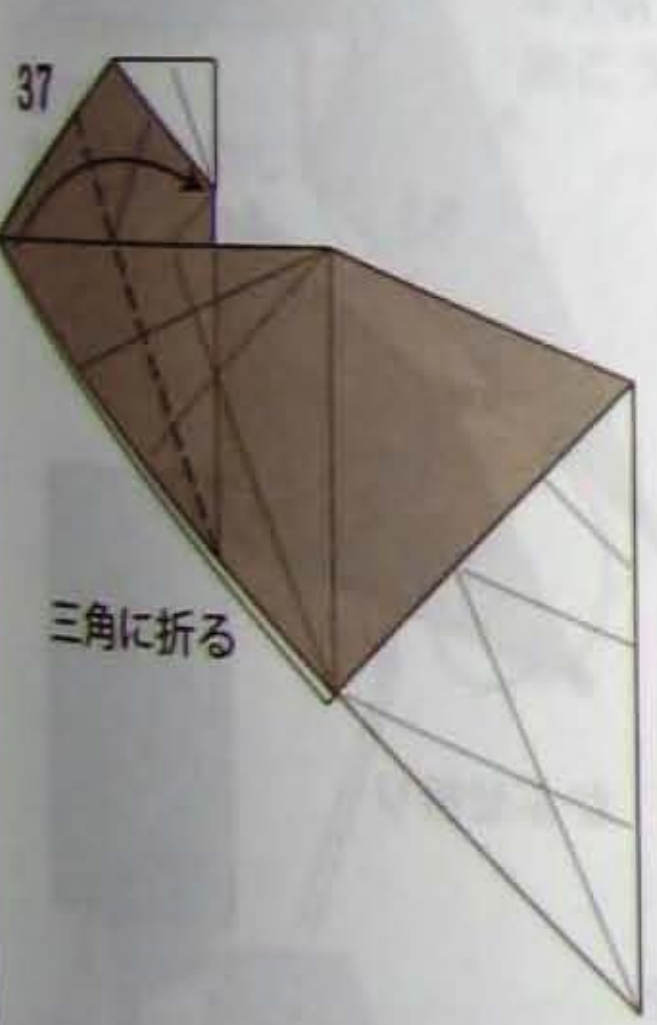

三角に折る

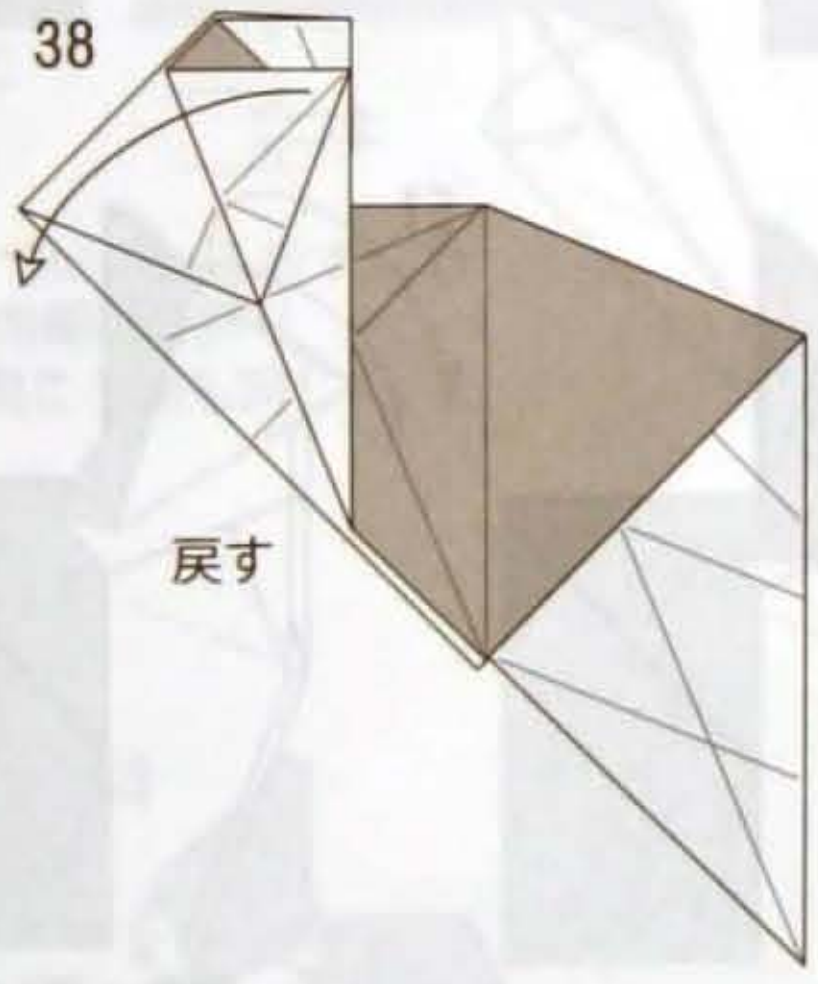

戻す

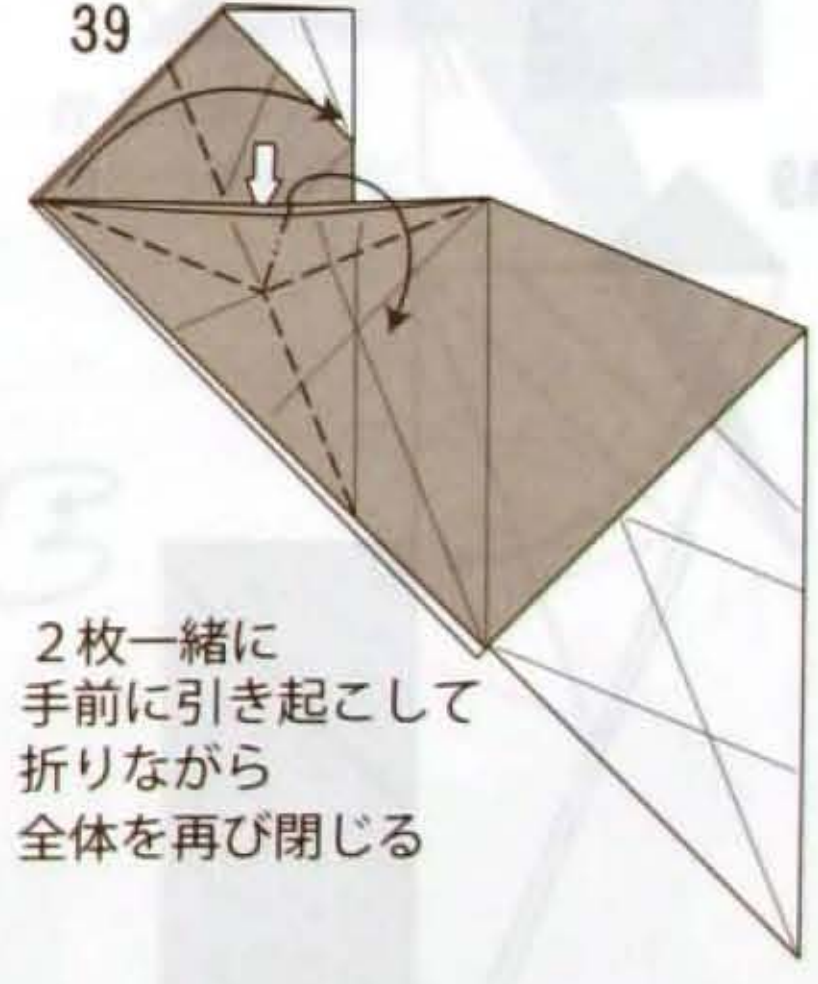

2枚一緒に手前に引き起こして折りながら全体を再び閉じる

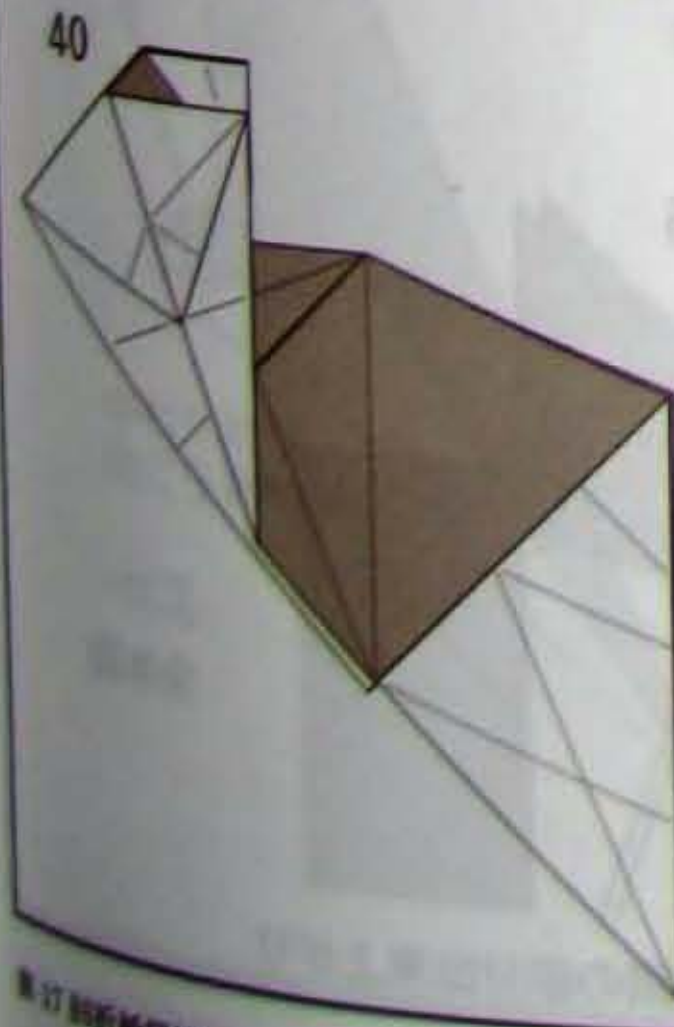

うらがえす

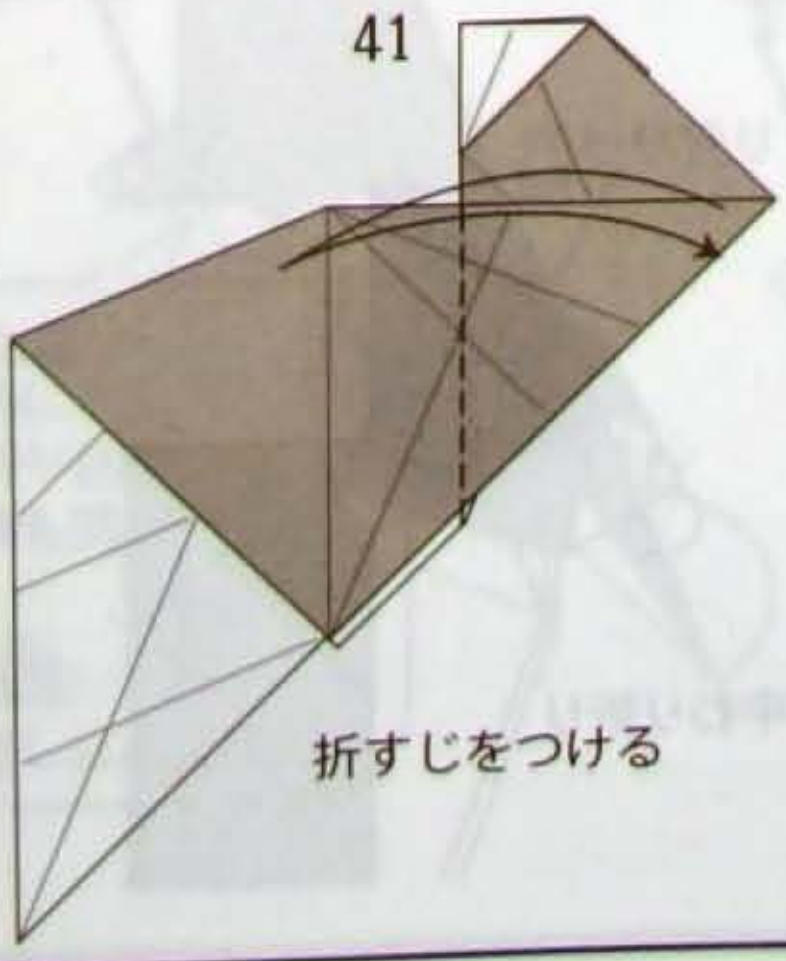

折すじをつける

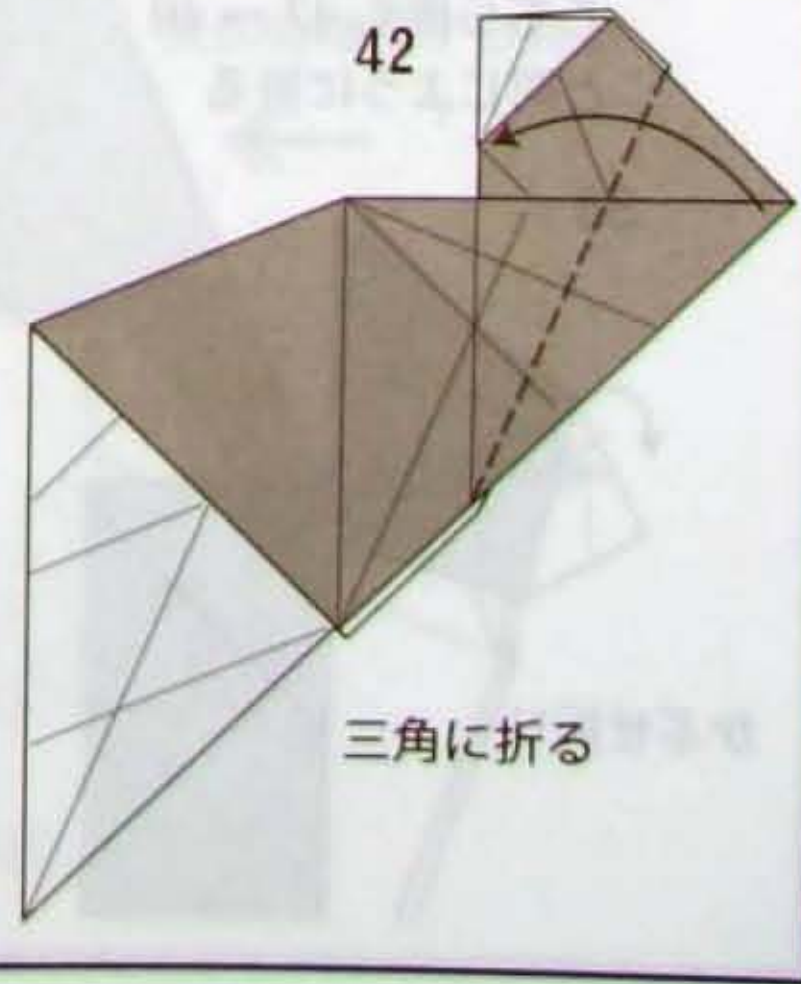

三角に折る

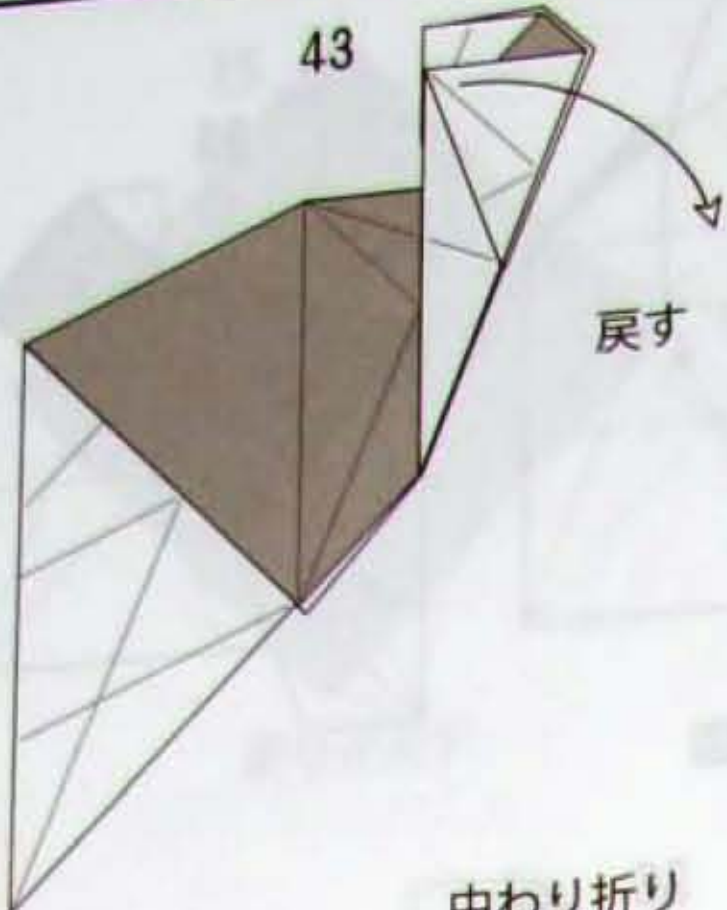

戻す

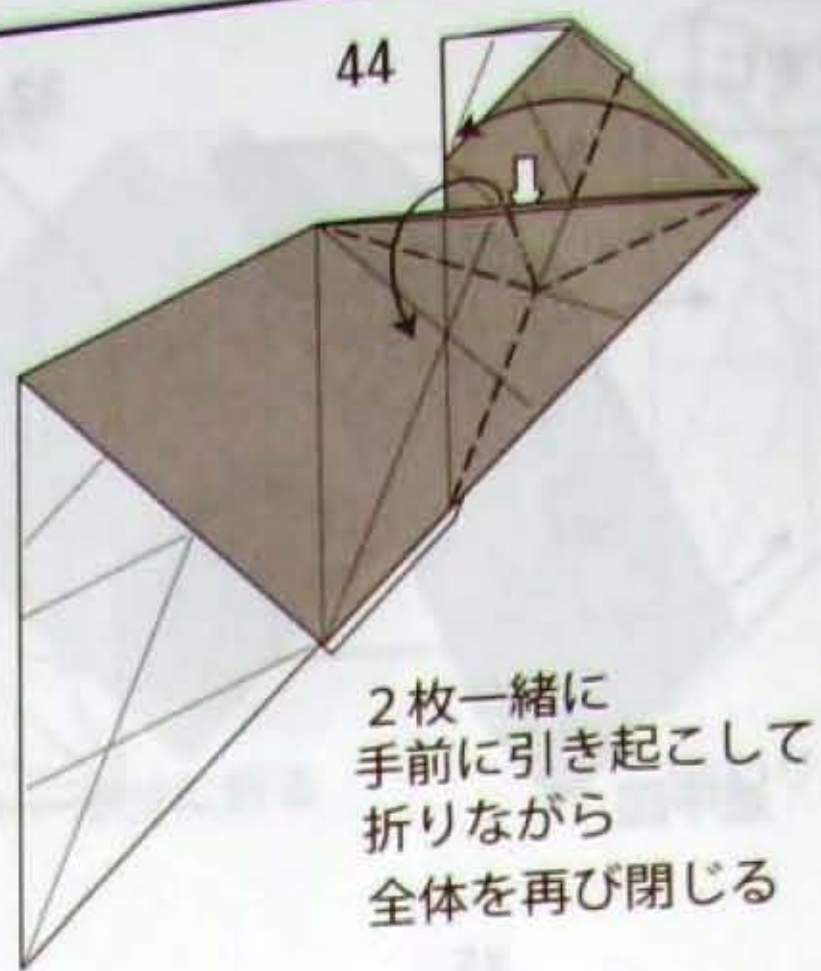

2枚一緒に手前に引き起こして折りながら全体を再び閉じる

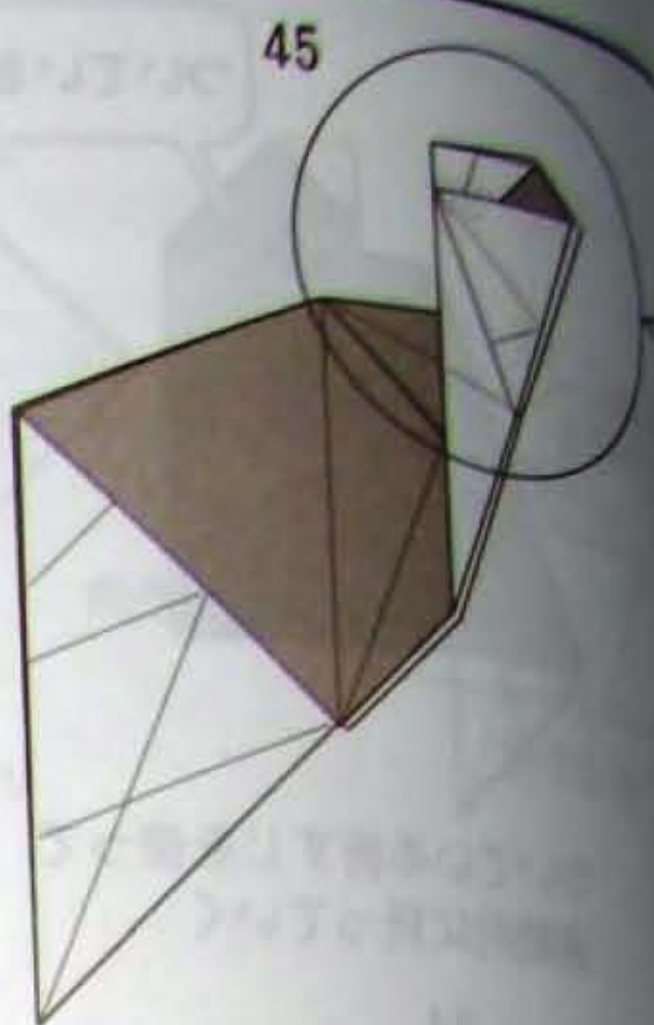

46 中わり折り

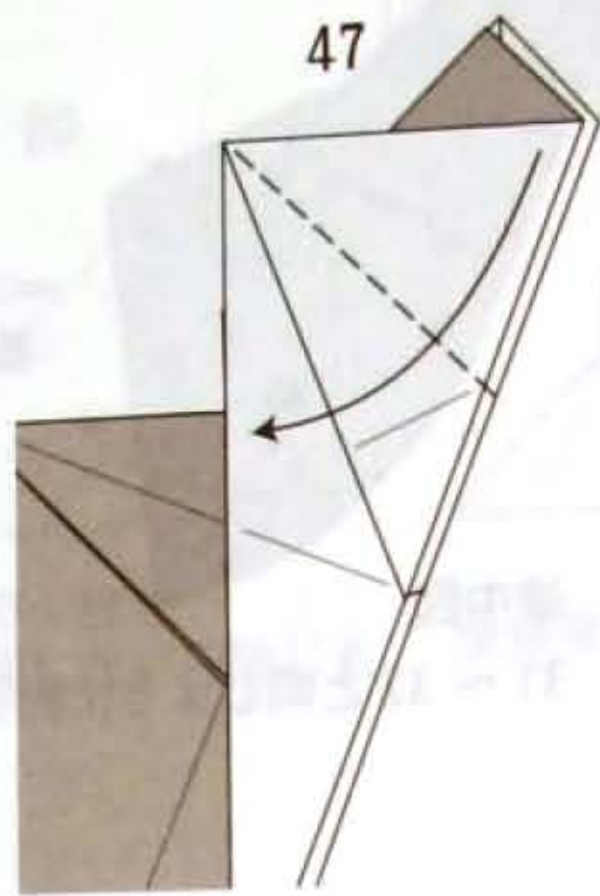
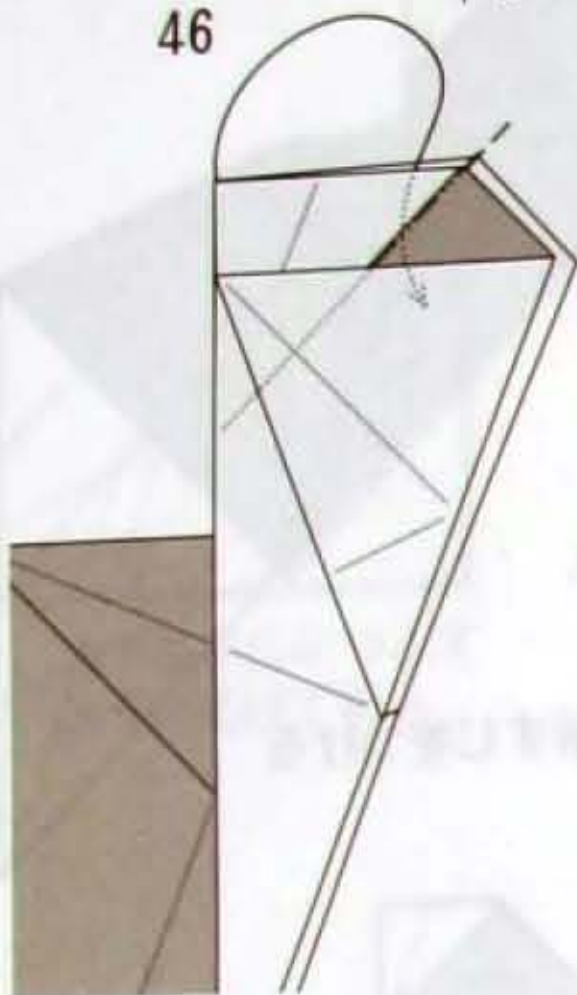

47

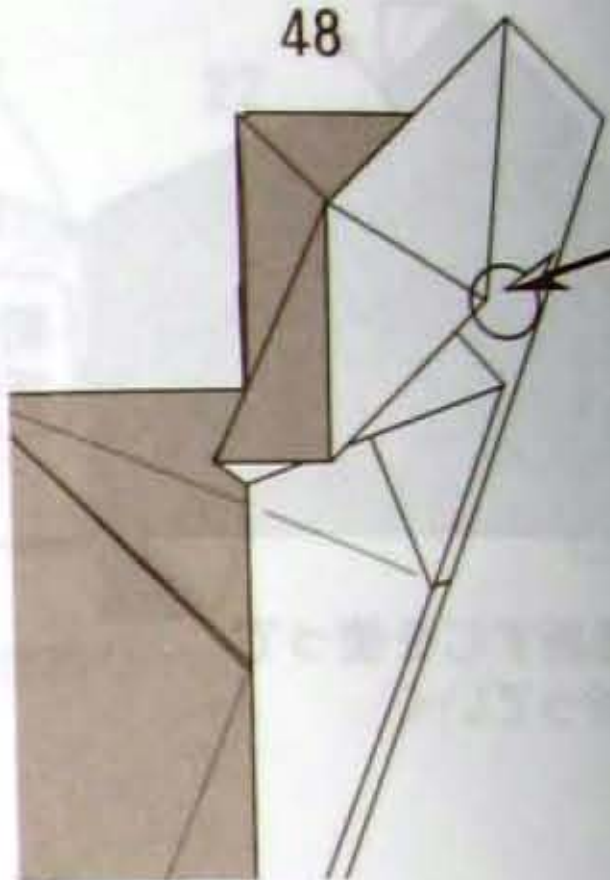

48

ここはいつも折れる位置まで折る

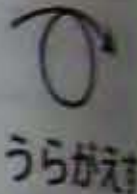

うらがえす

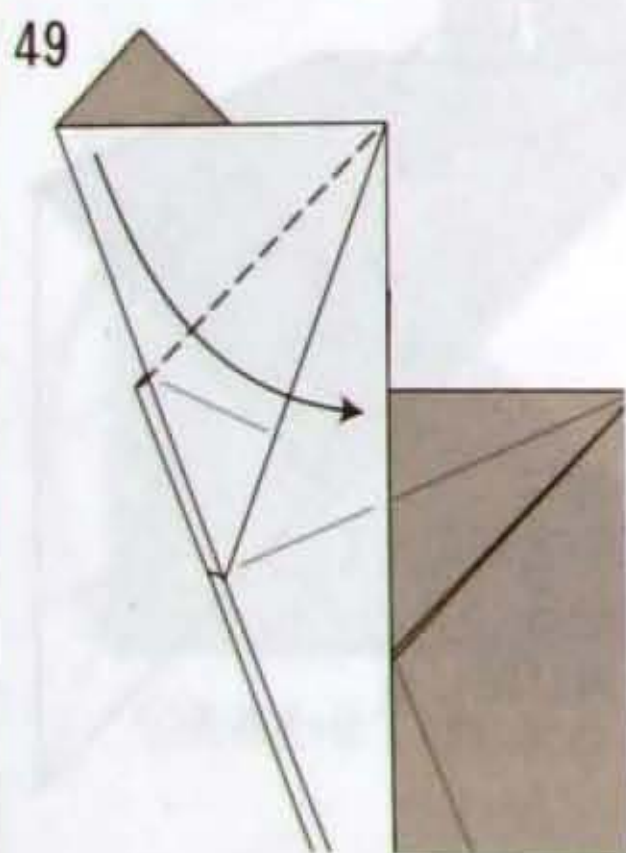

49

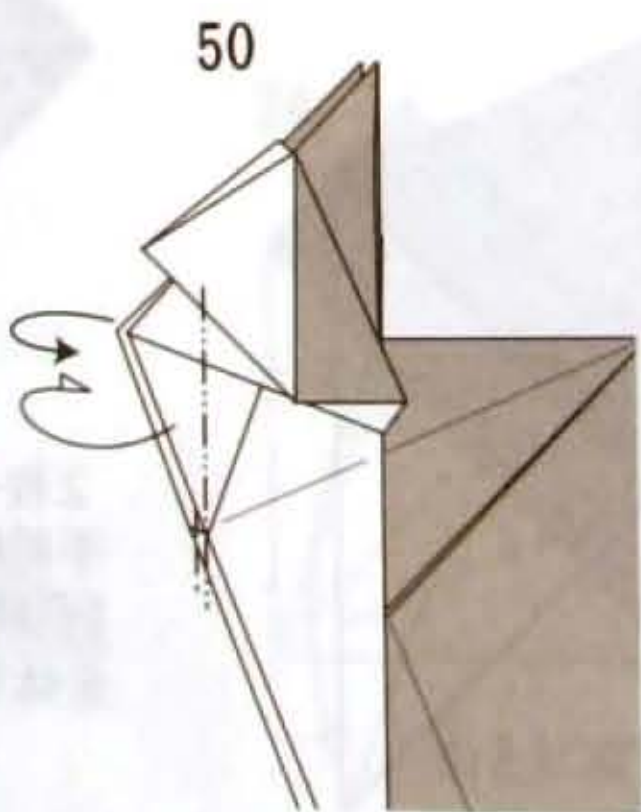

50

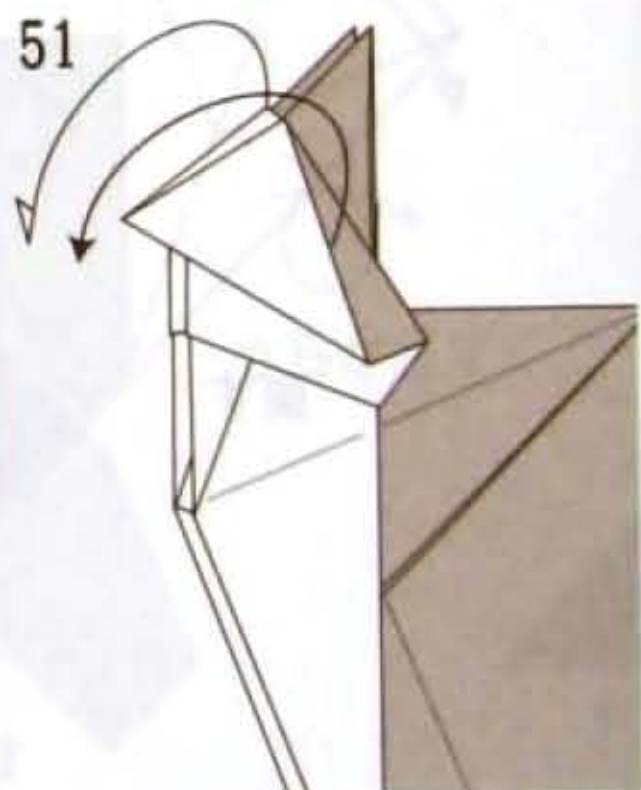

51



52

かぶせ折り

こちら側も 47~48 と同じように折る

内側に折り込む

重なっている部分を折り返して外に出す

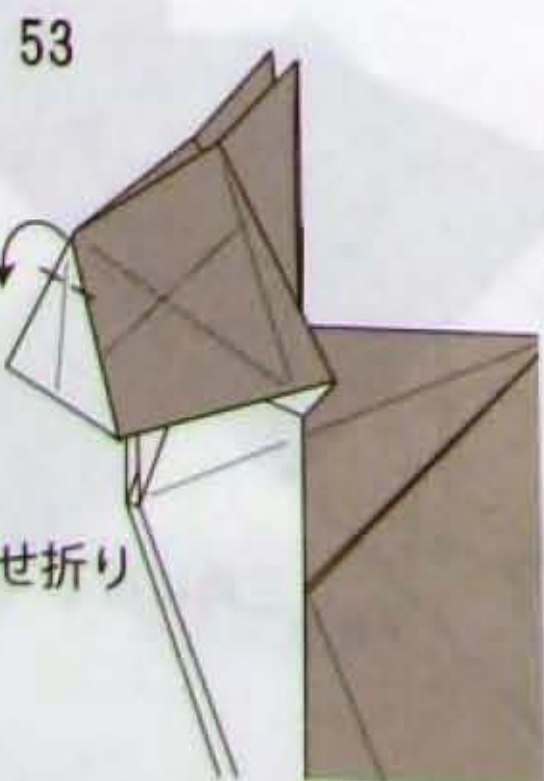

53

かぶせ折り



54

中わり折り

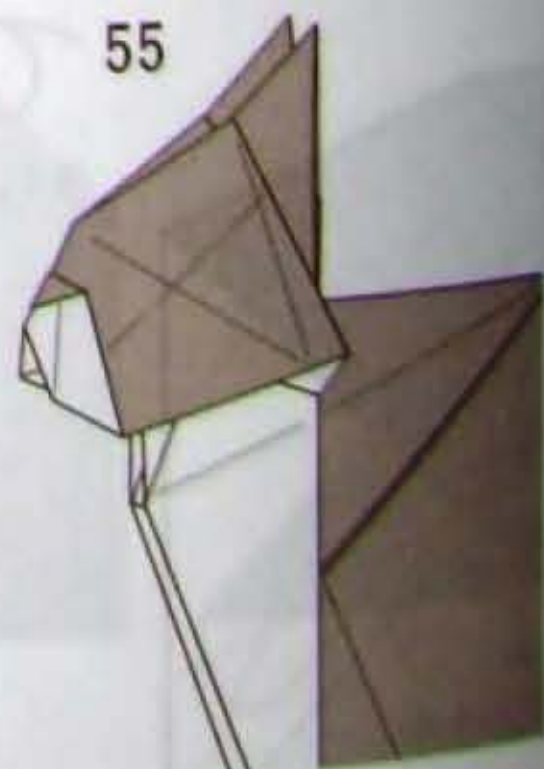

55

顔の部分出来上がり

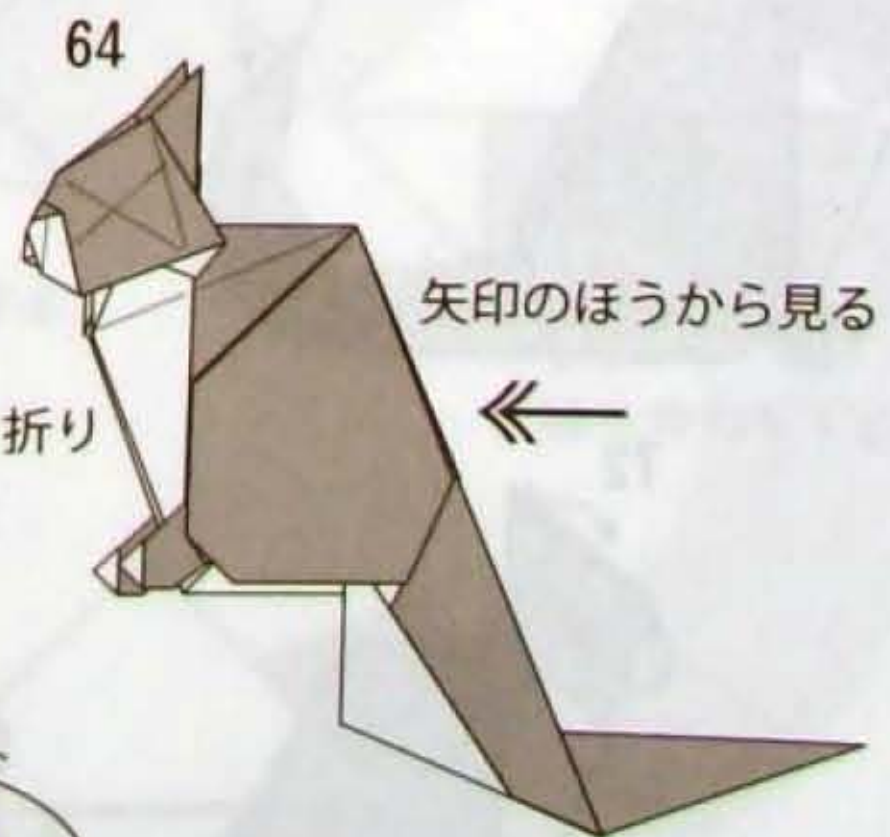
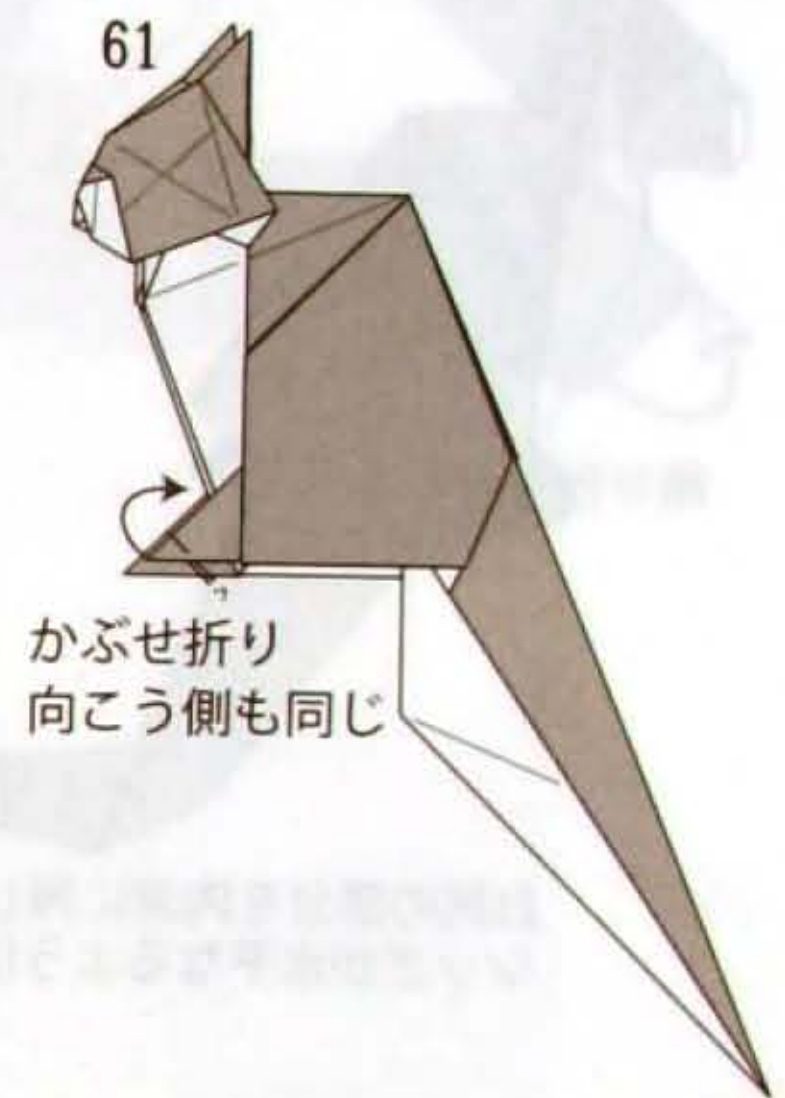
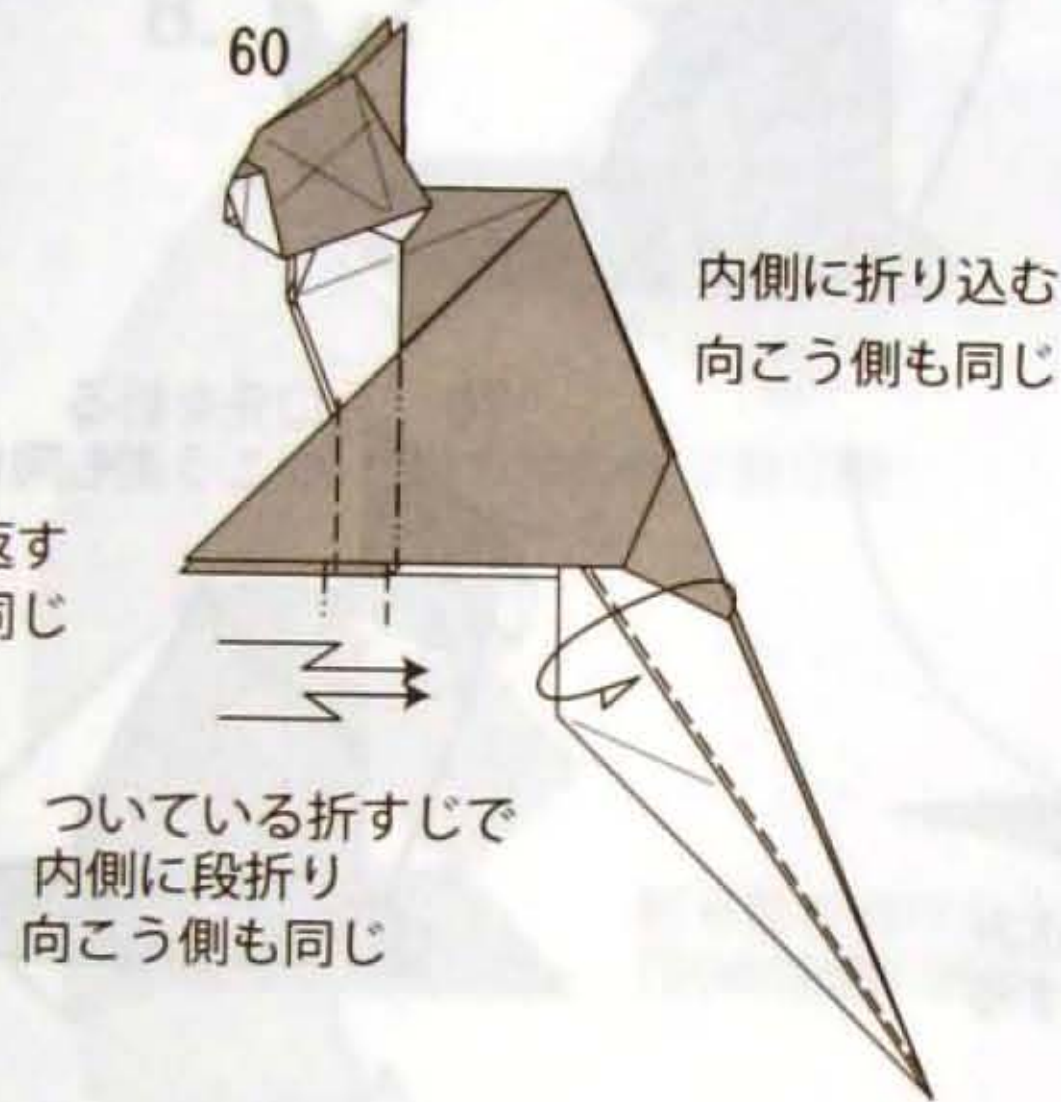
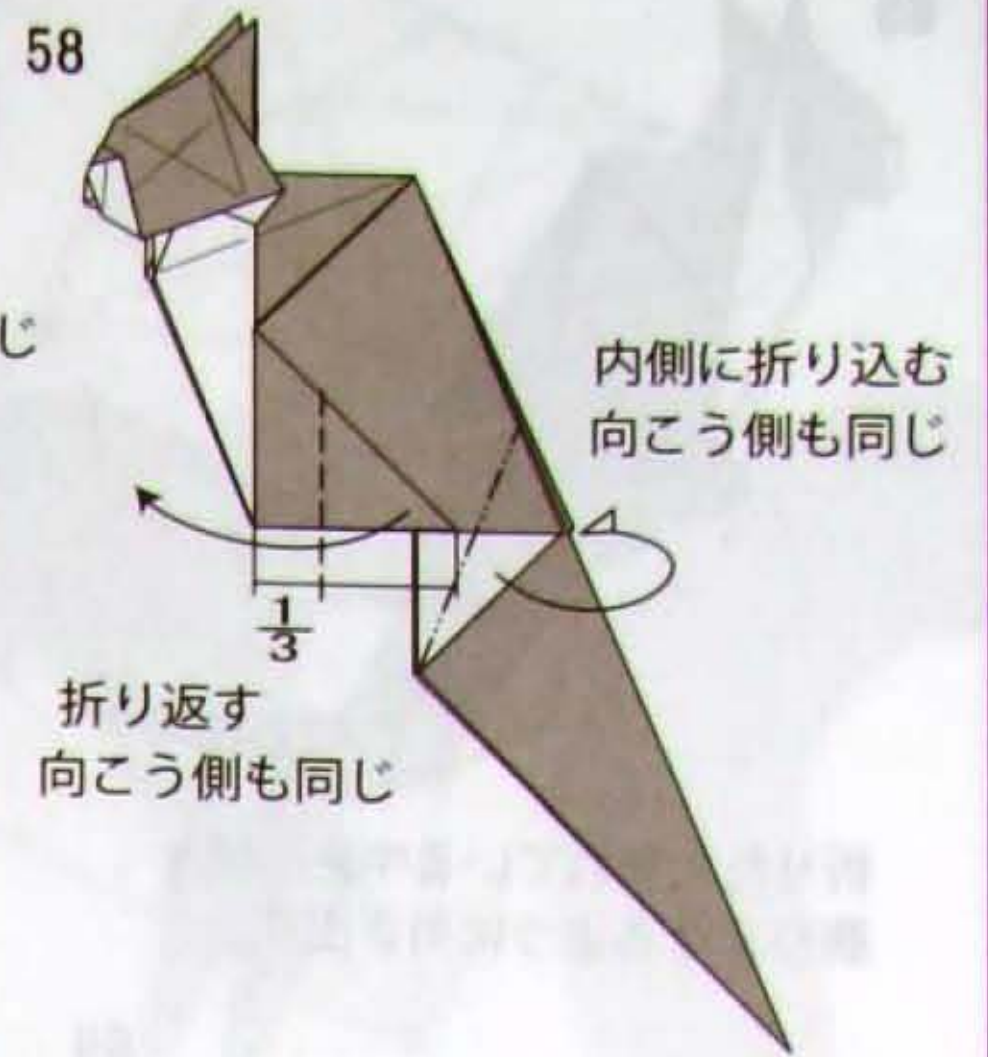
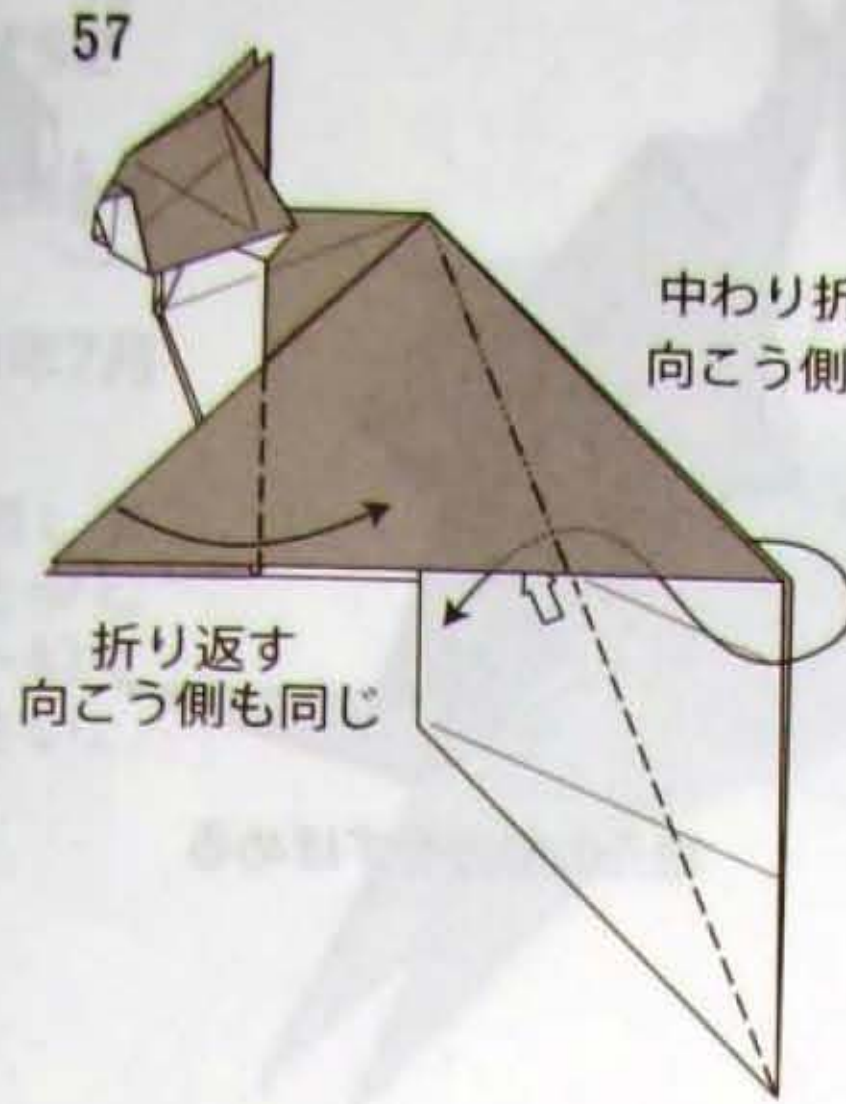
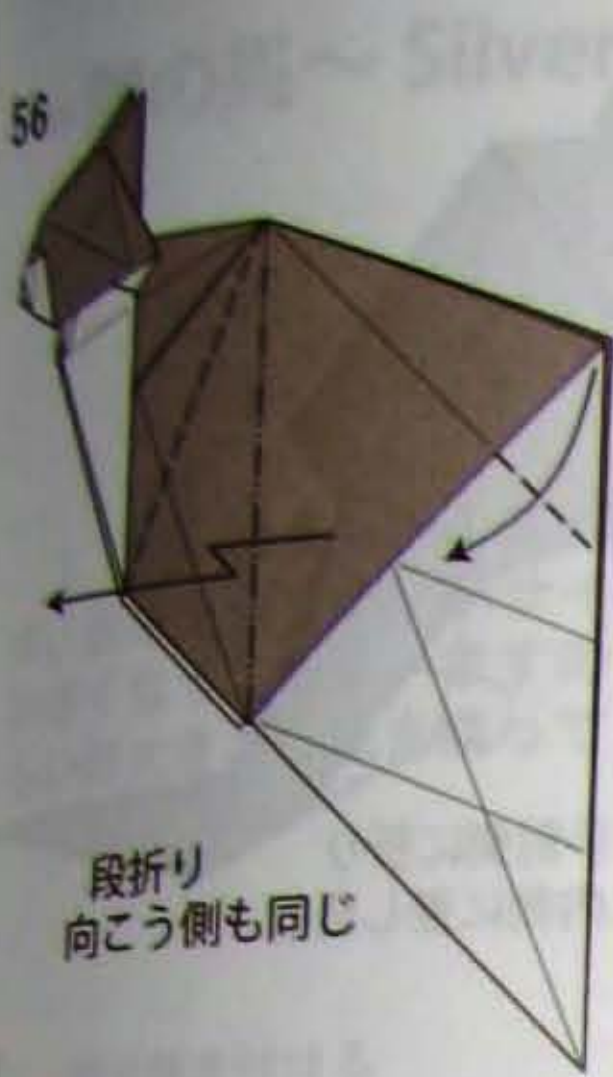

65

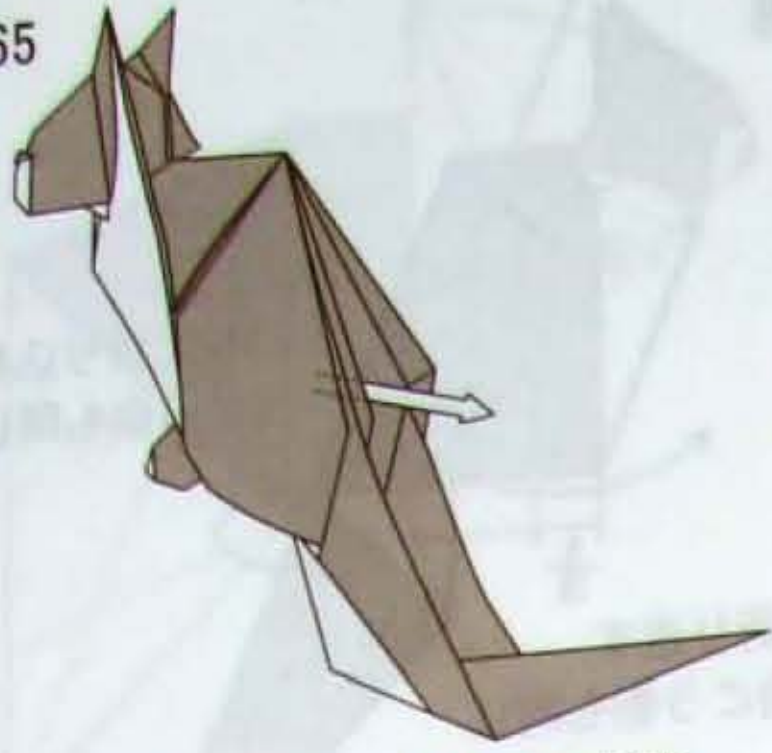

折りたたまれている中央の紙を膨らませるように引き出す

66

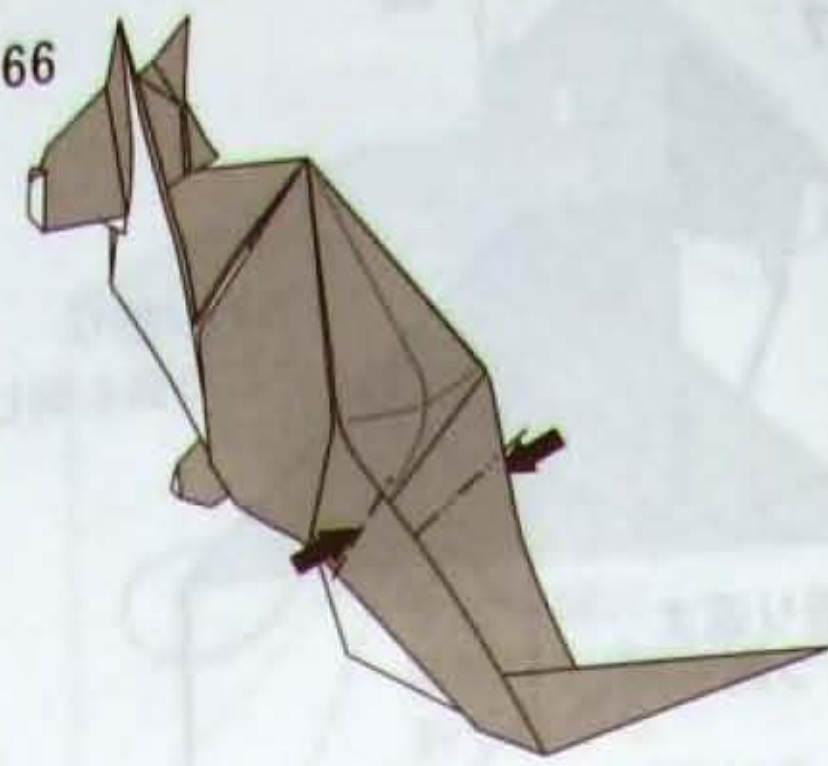

根元の部分をすぼめる

67

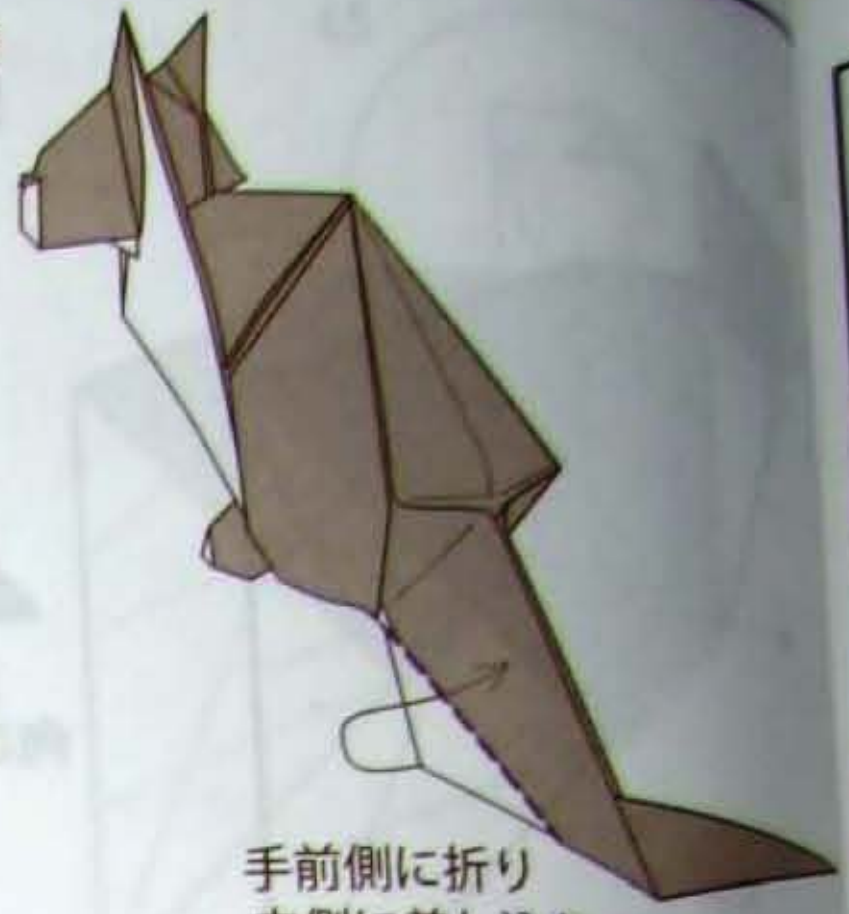

手前側に折り内側に差し込む

68

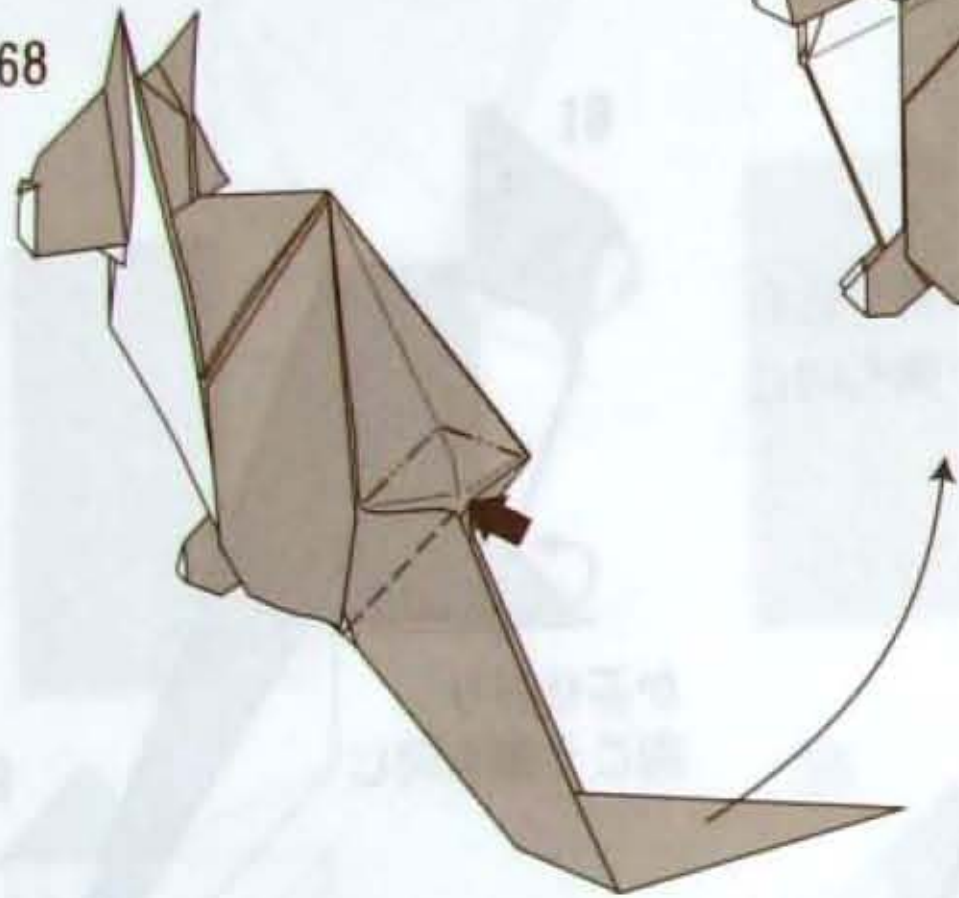

お尻の部分を内側に押し込みシッポが水平なるようにする

69

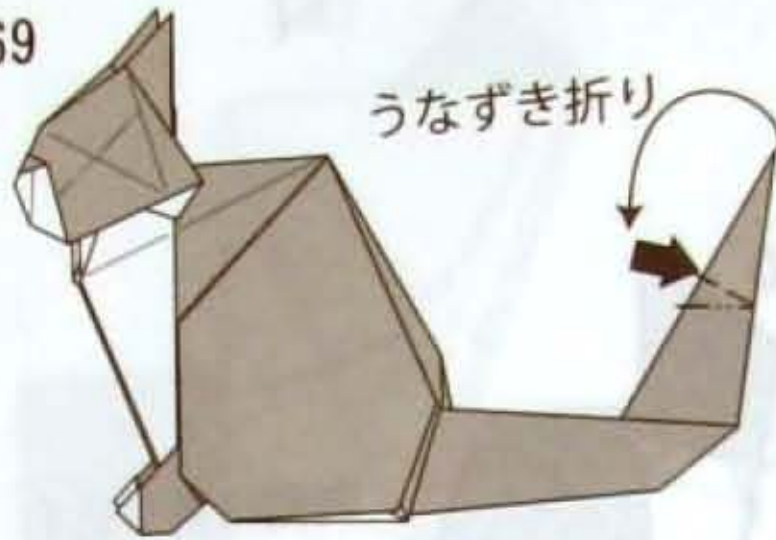

うなずき折り

70

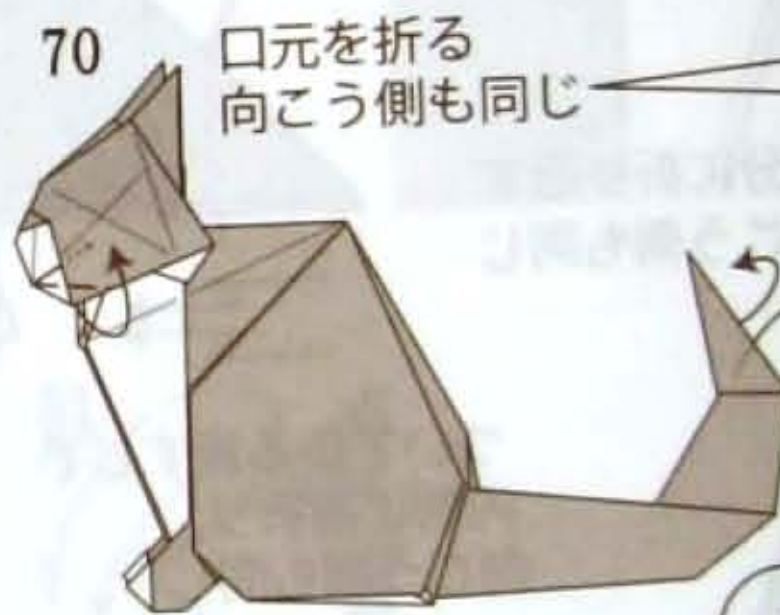

口元を折る向こう側も同じ



拡大図

内側の重なりを外に引き出す向こう側も同じ

71

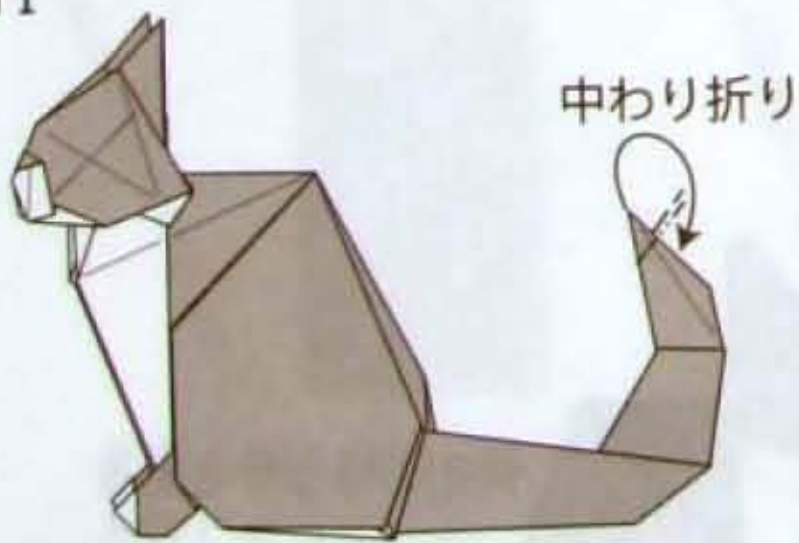

中わり折り

72

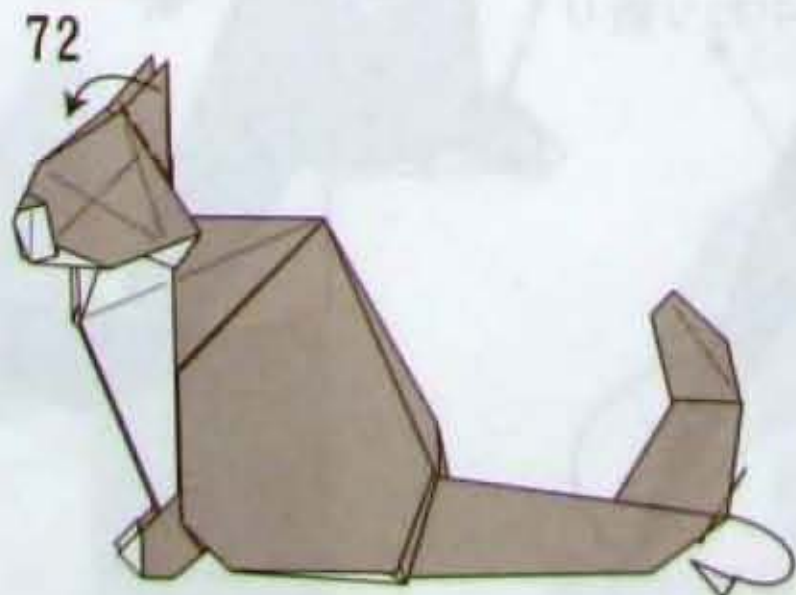

耳を折る 内側に折り込む 向こう側も同じ 向こう側も同じ

73

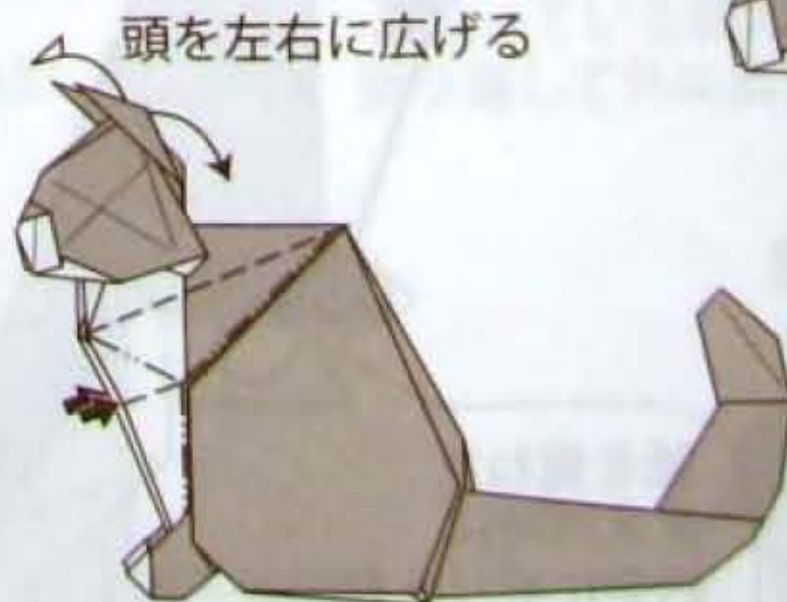

頭を左右に広げる

体全体に立体感が出るように折すじをつける 向こう側も同じ

74

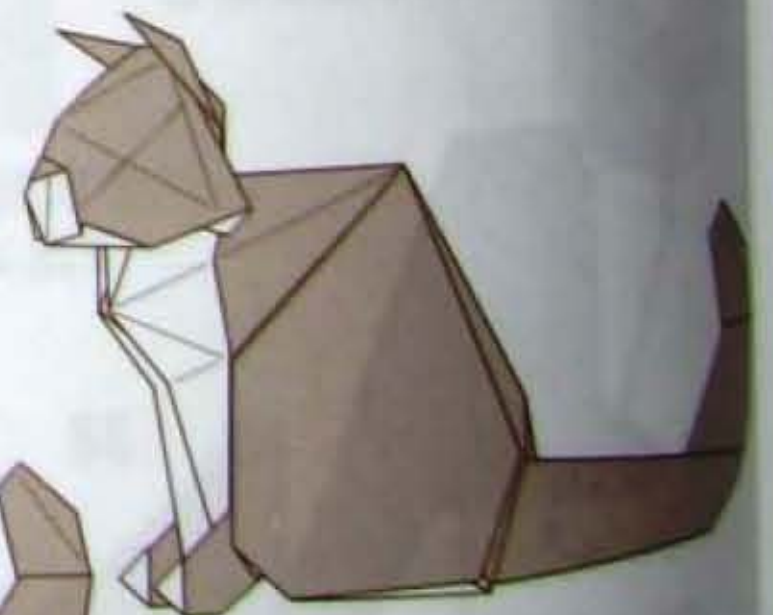

出来上がり

~銀の

1: 折す。出来小さくなるらしいの

1. 折り

2. 折り

~銀の馬~ Silver Horse

By Kasumi Seishi

作/霞 誠志 2010年7月

1:√2 の長方形の用紙を使用します。出来上がりが、A4サイズだと少し小さくなってしまいますのでB4~A3ぐらいの大きさの紙を使ってください。

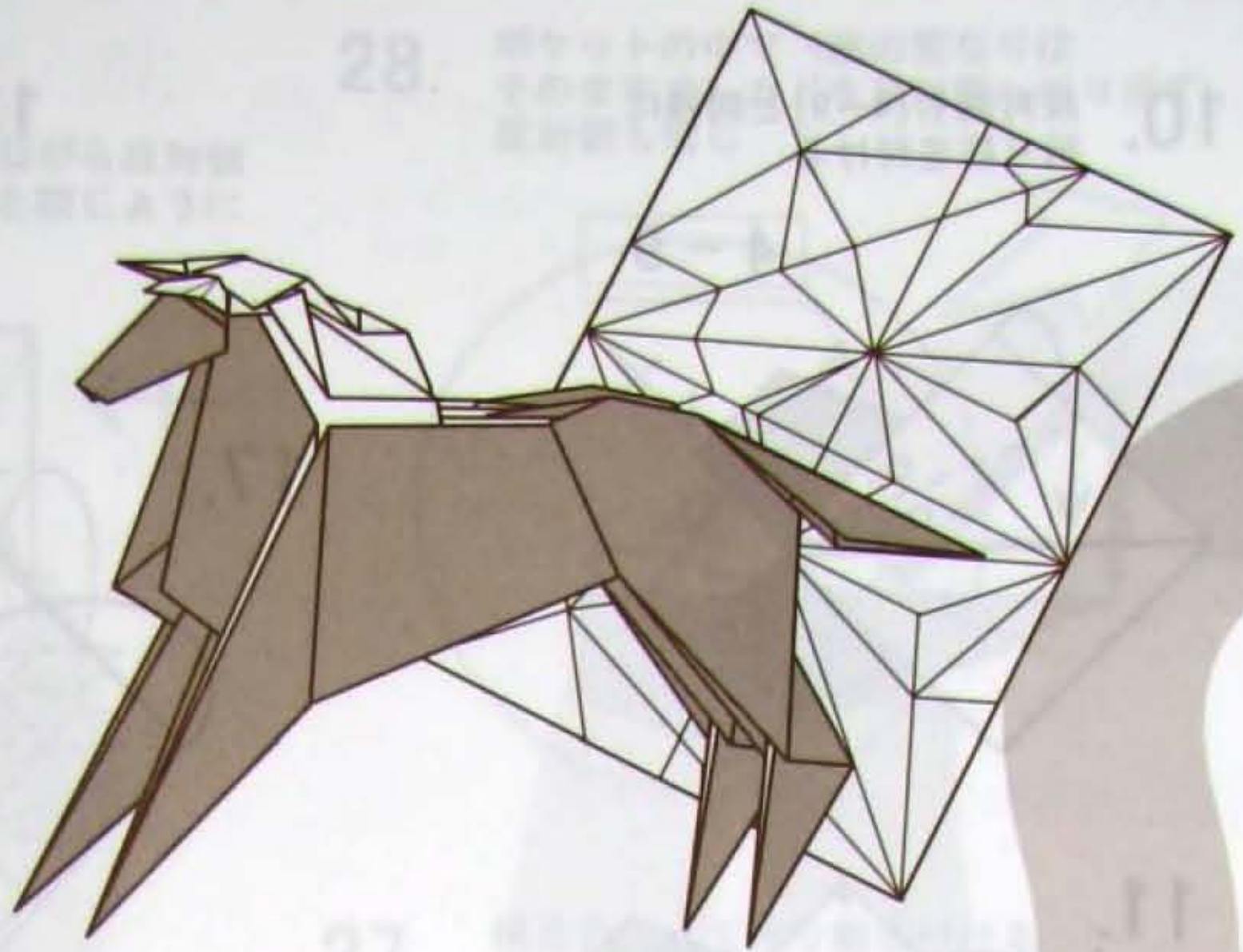

1. 折り筋を付ける

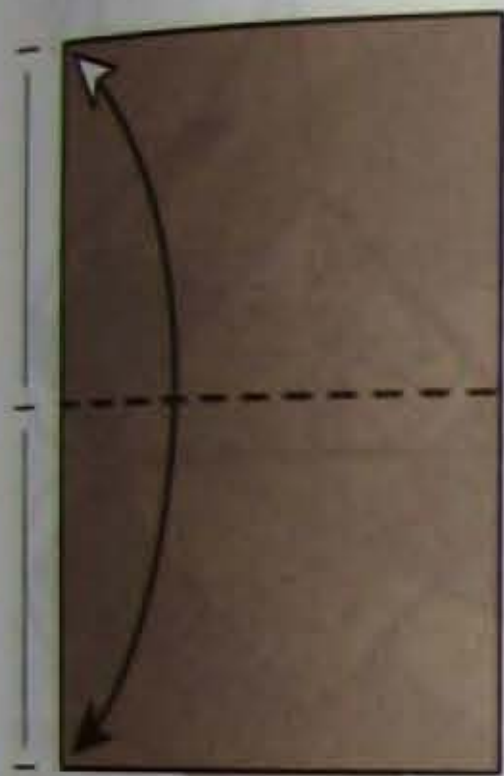

2. 縁を折り筋に合わせて折る

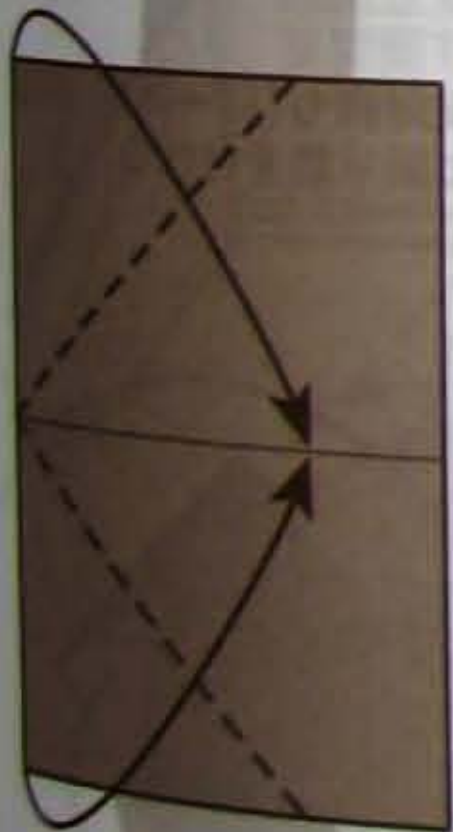

下の部分を出すように折る
反対側も同じ

7.

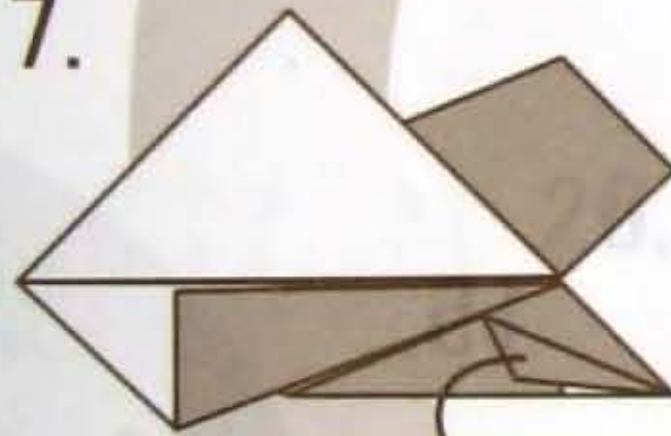

8.

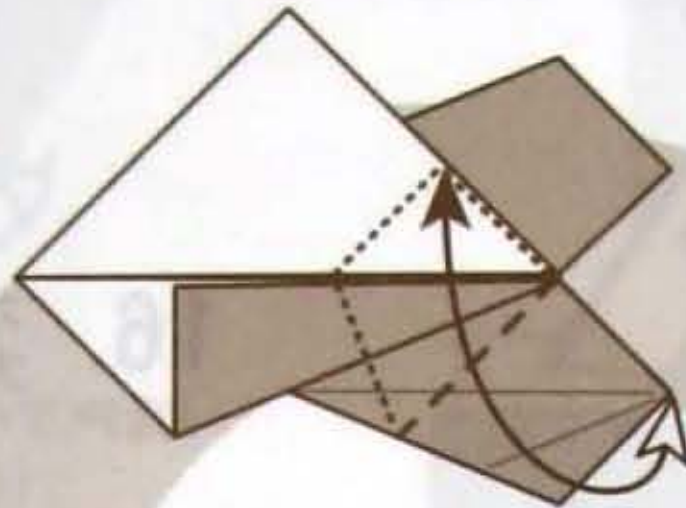

縁を合わせて折り筋を付ける

9.

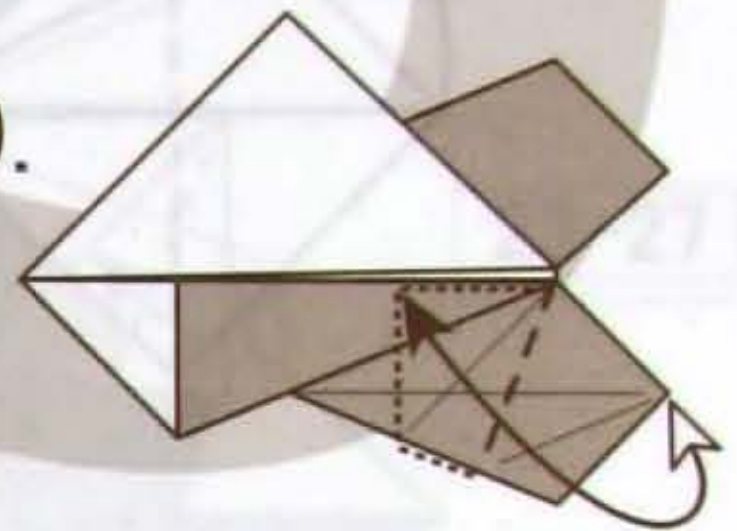

縁を合わせて折り筋を付ける

折り筋を付けたら、
[5]の状態に戻す

6.

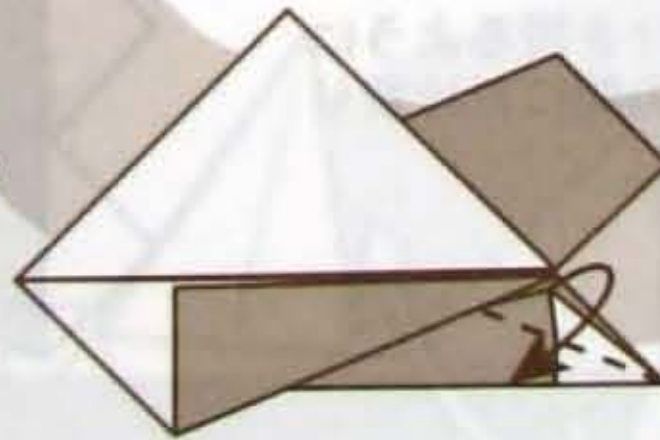

縁を合わせて折る

5.

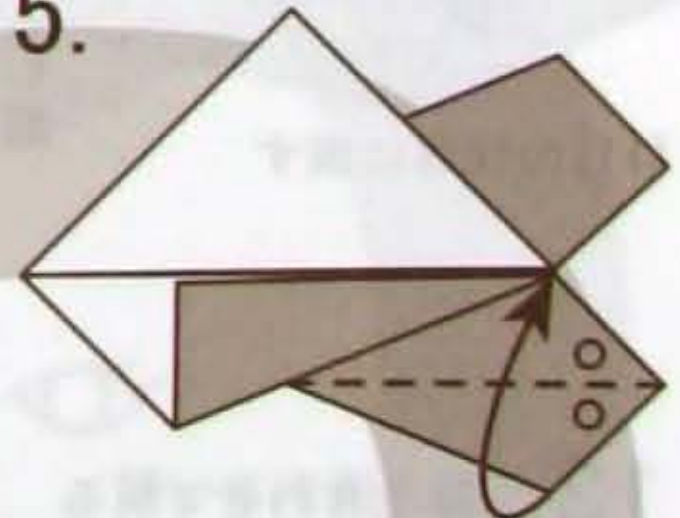

縁を合わせて折る

4.

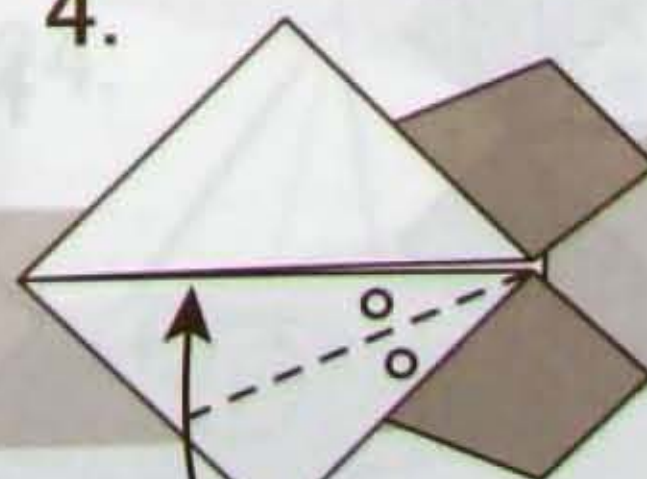

縁を合わせて折る

3.

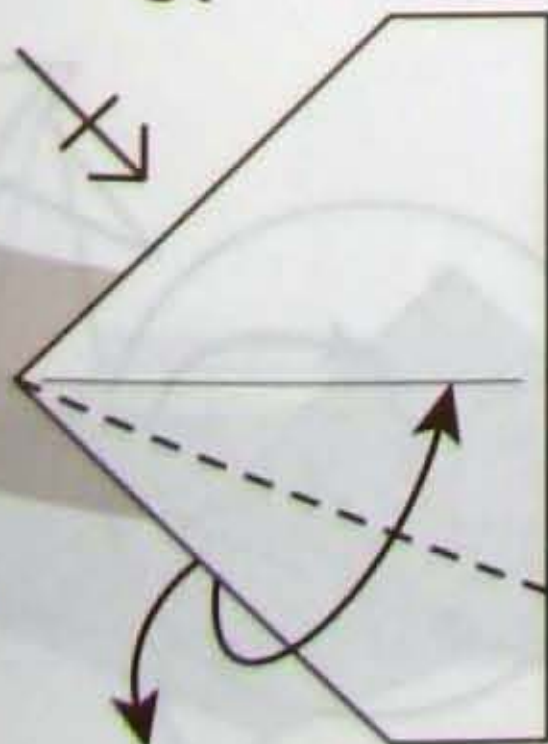

10. 反対側も [4~9] と同様に
折り筋を付ける

4-9

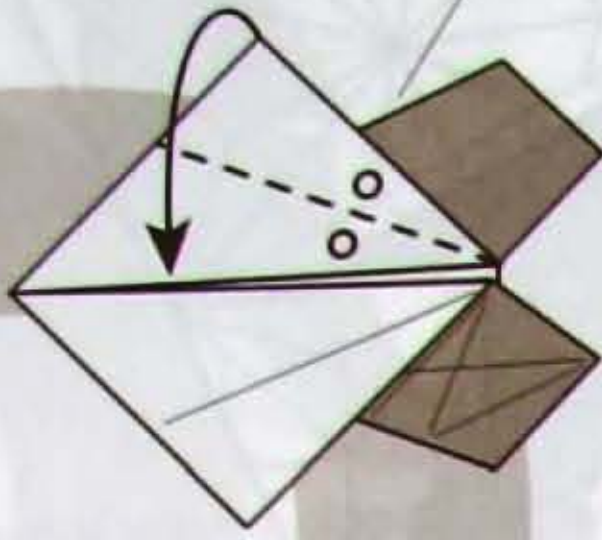

11.

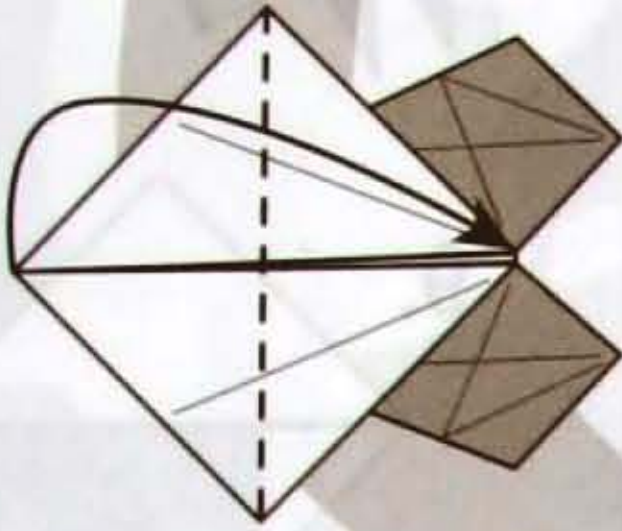

12.

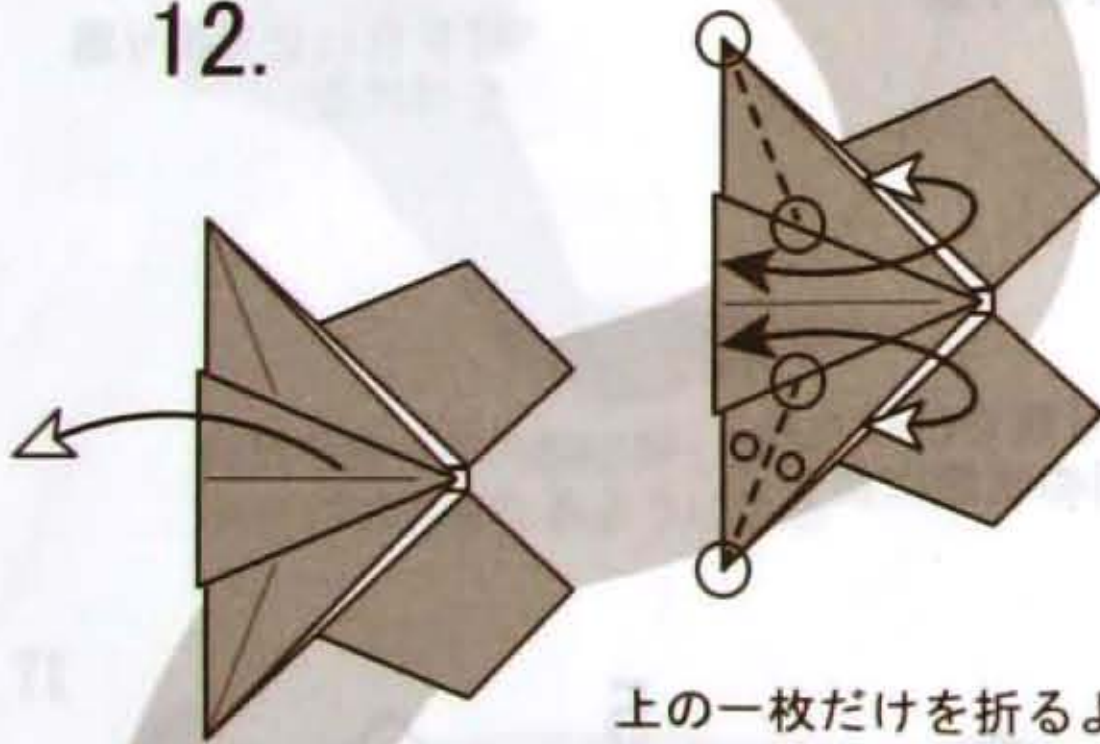

[11]の状態に戻す

上の一枚だけを折るように
して、○印の間にだけ折り
筋を付ける

13. 縁を合わせて折る

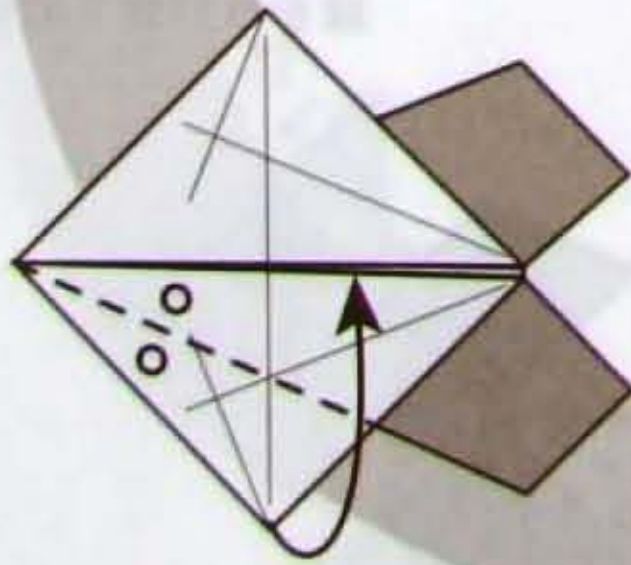

14.

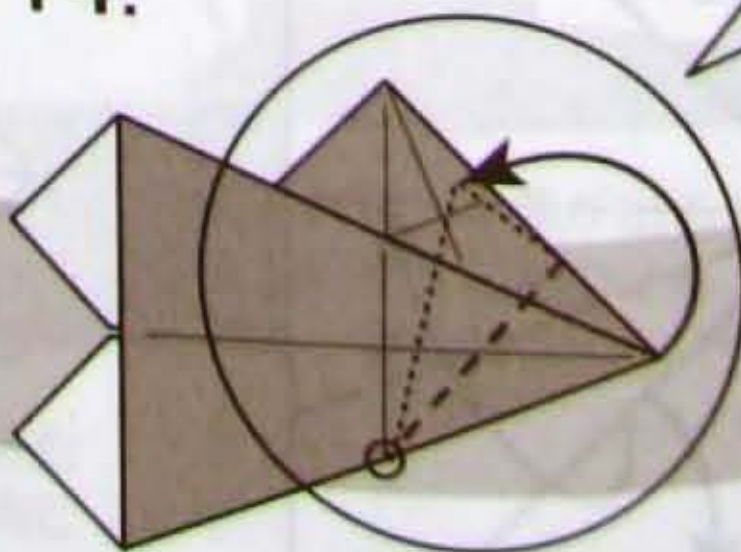

○印を基点に縁を折り筋の
交点と一致させるようにし
て折り筋を付ける

18. [14]で付けた折り筋
で折る
この時浮いてくる部
分は次の図のように
平らに畳む

17.

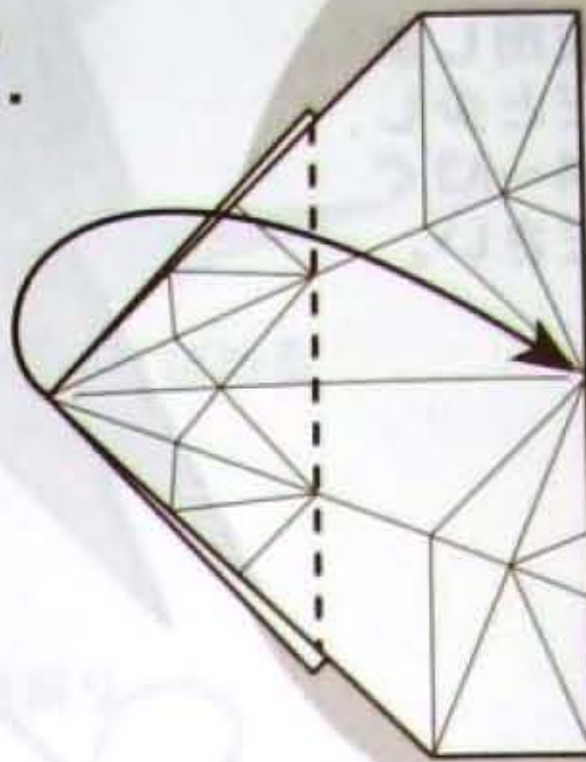

16. カドを反対側へ
大きく折り返す

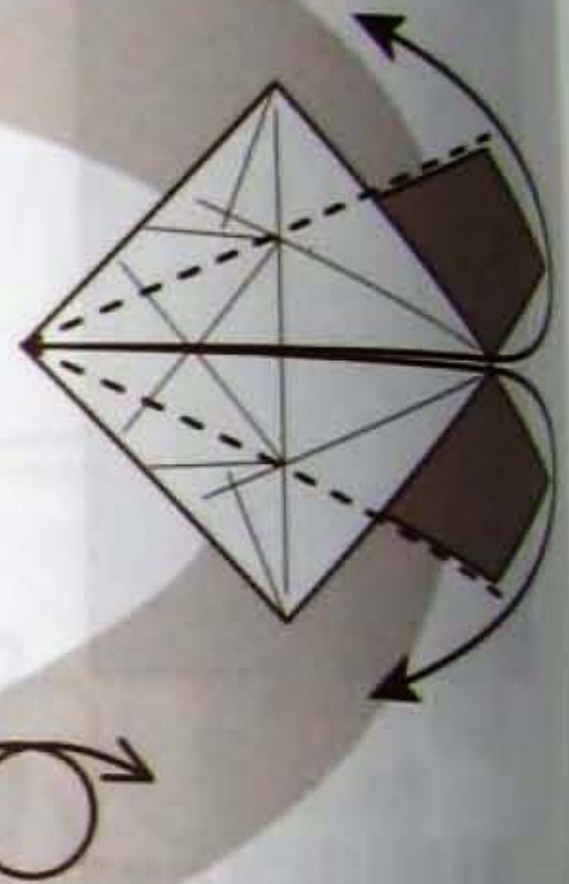

15.

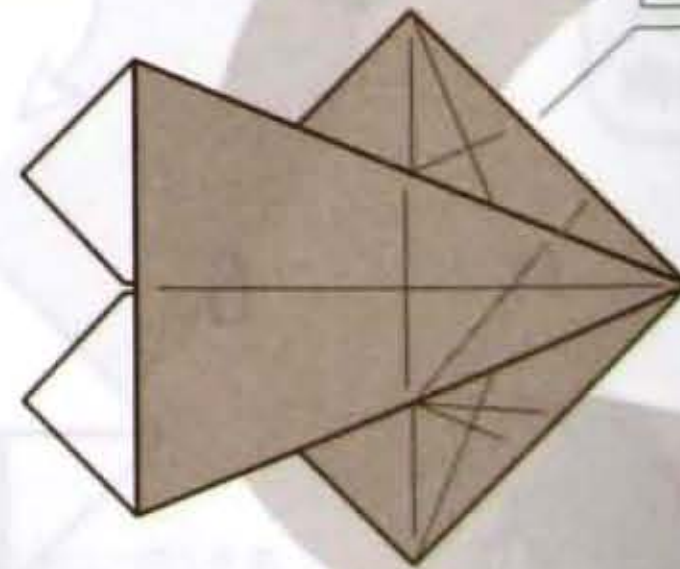

反対側も [13~14] と同様
に折り筋を付ける

19.



21.

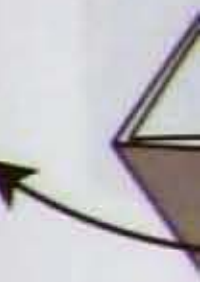

いっぱい
まで紙を引
反対側も同

22.



19. 途中図



20. 半分に折りながら反対側を[18~19]と同じようにまとめる

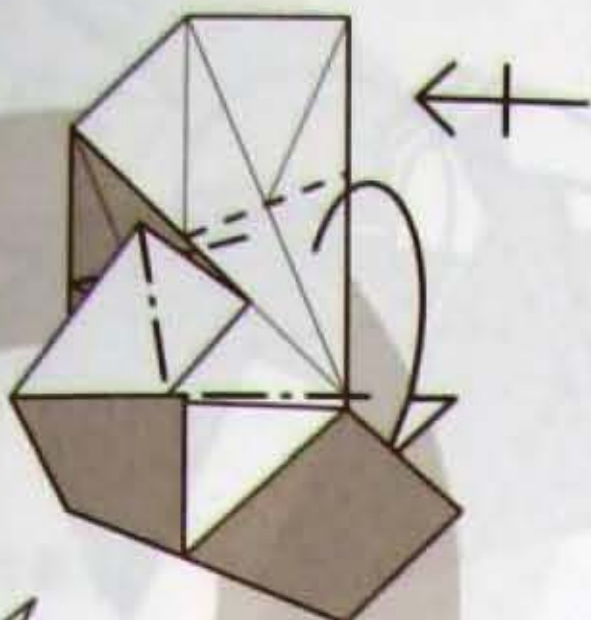

28. ポケットの中で(紙の重なりはそのままで)カドを反対側へ折り返す 反対側も同じ

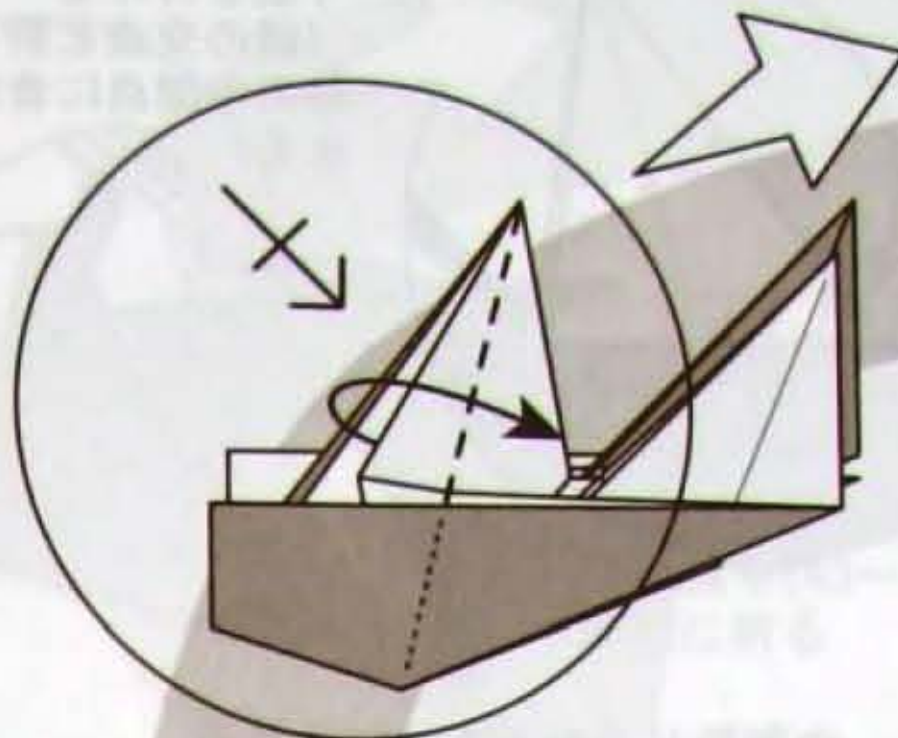

21.

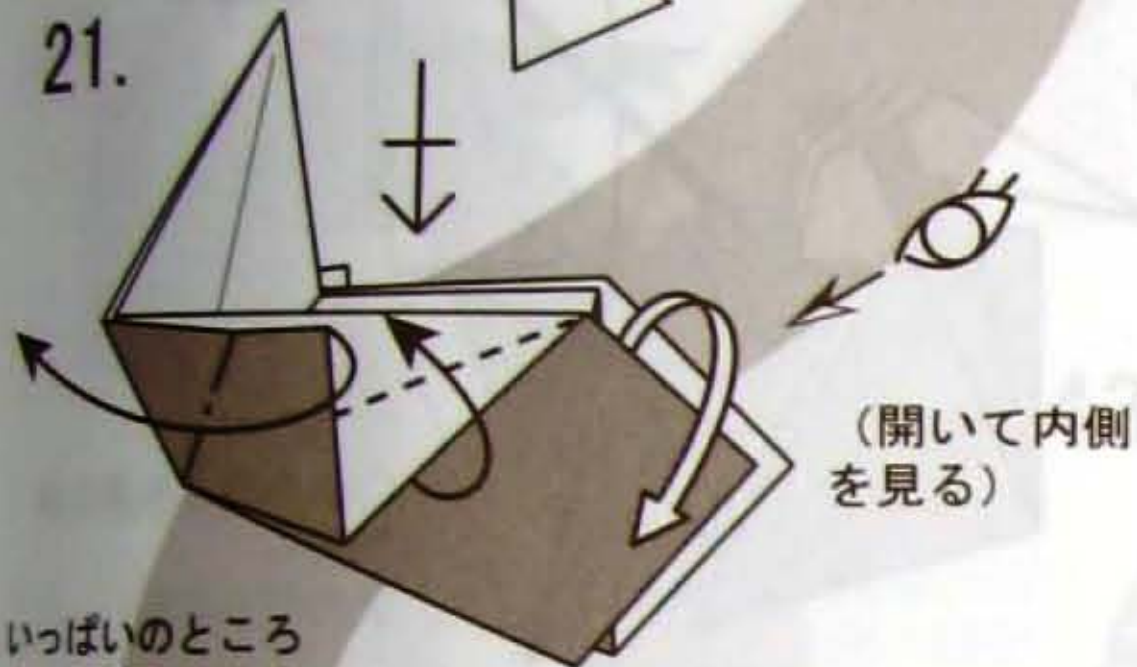

(開いて内側を見る)

いっぱいのところまで紙を引き出す 反対側も同じ

27. 縁を合わせて折り筋を付ける 反対側も[23~27]と同様に折る

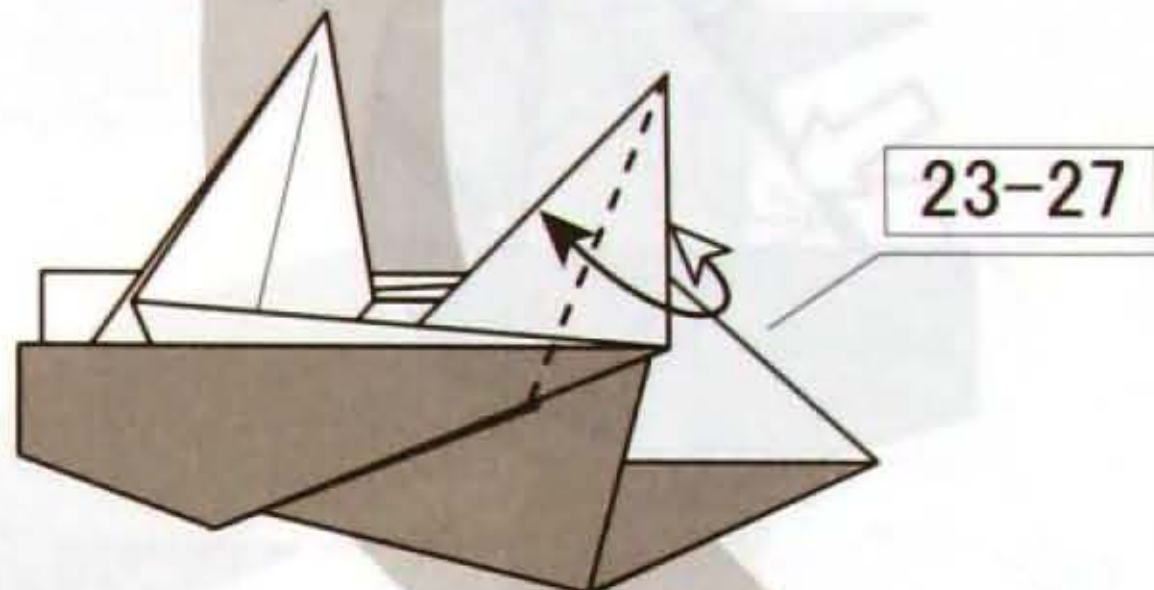

23-27

22.

[6]で付けた折り筋で中割折りしながら閉じる 反対側も同じ

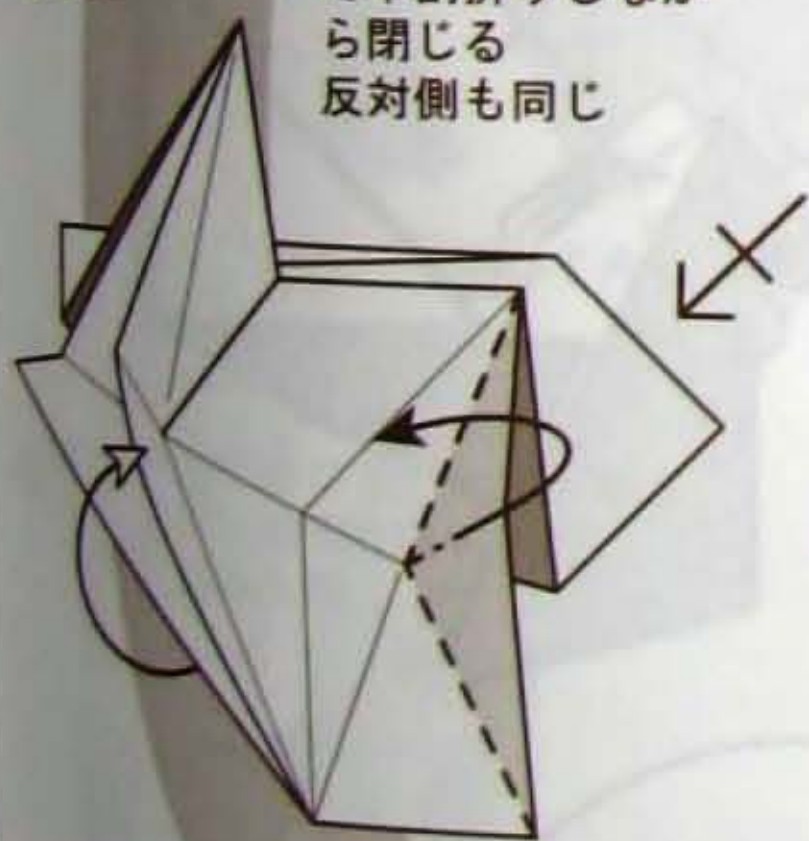

26. カドを間に折りながら閉じる

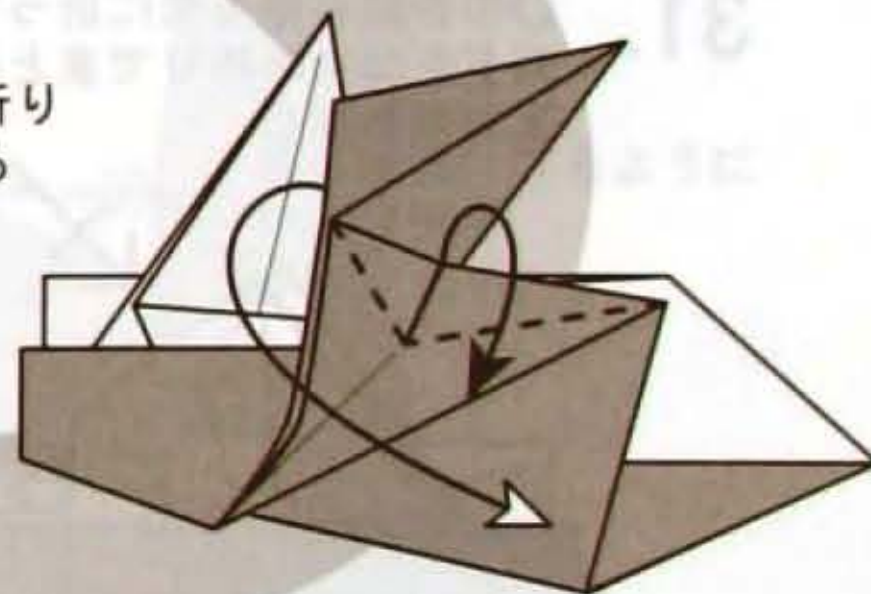

25.

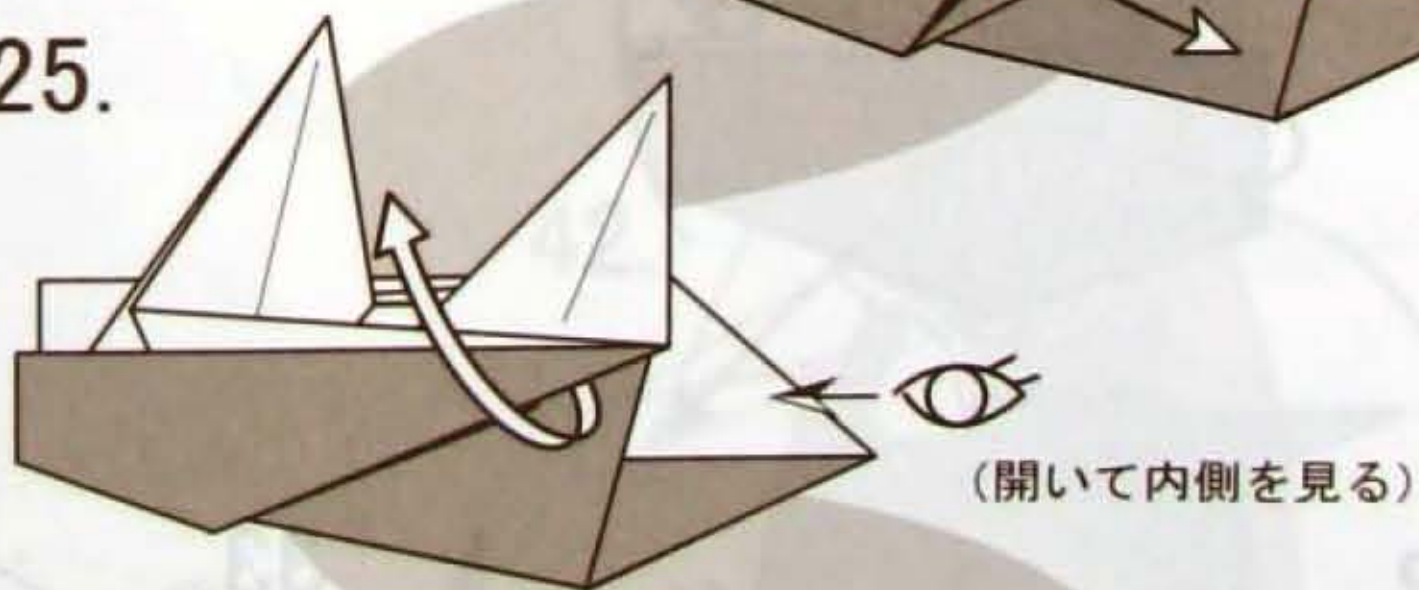

(開いて内側を見る)

23.

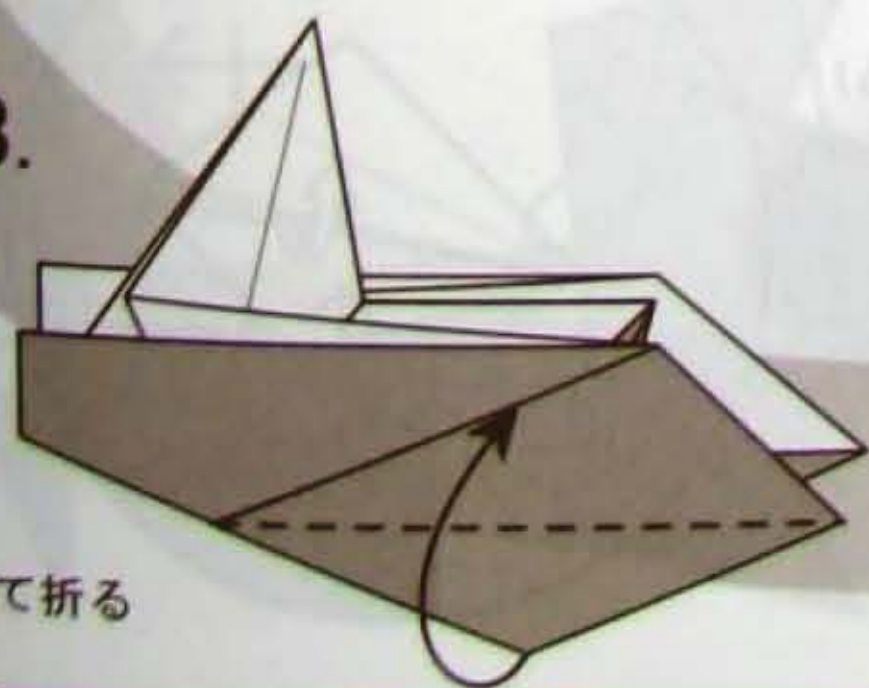

縁を合わせて折る

24.



紙を重ねたまま 全体を中割折り

同様

のし

29.

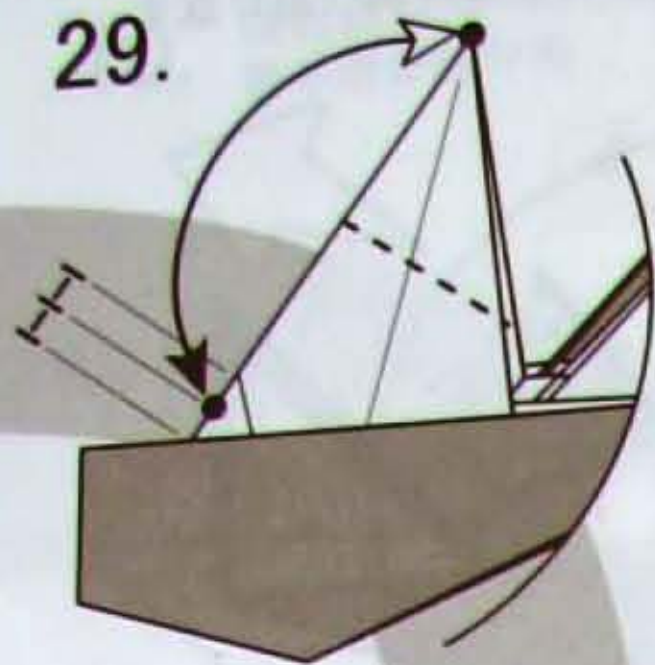

●印を合わせて折り筋を付ける
(緑の交点と折り筋の中間点に合わせる)

30. 中割折りでカドを中に入れる

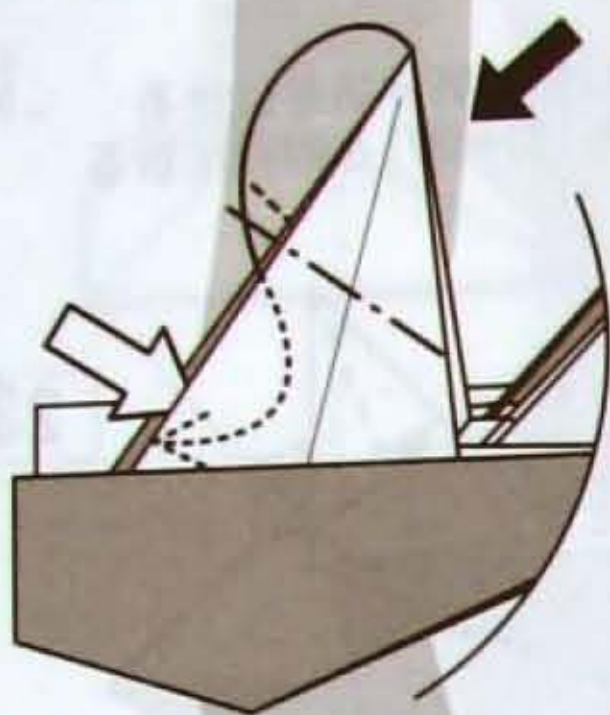

31. ○印を結ぶ線を先に折ってからカドをつまみ折りでまとめる
反対側も同じ

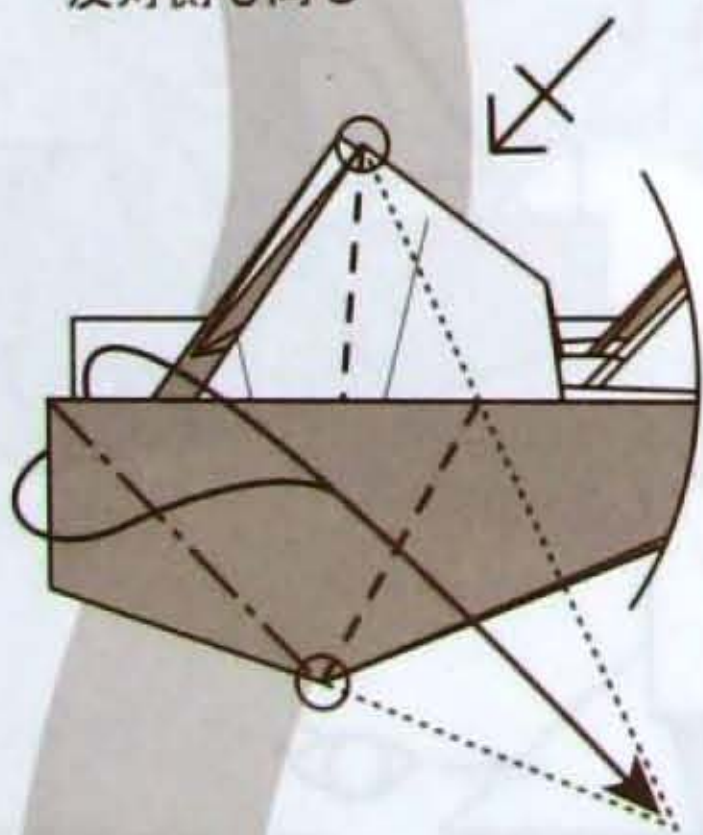

32.

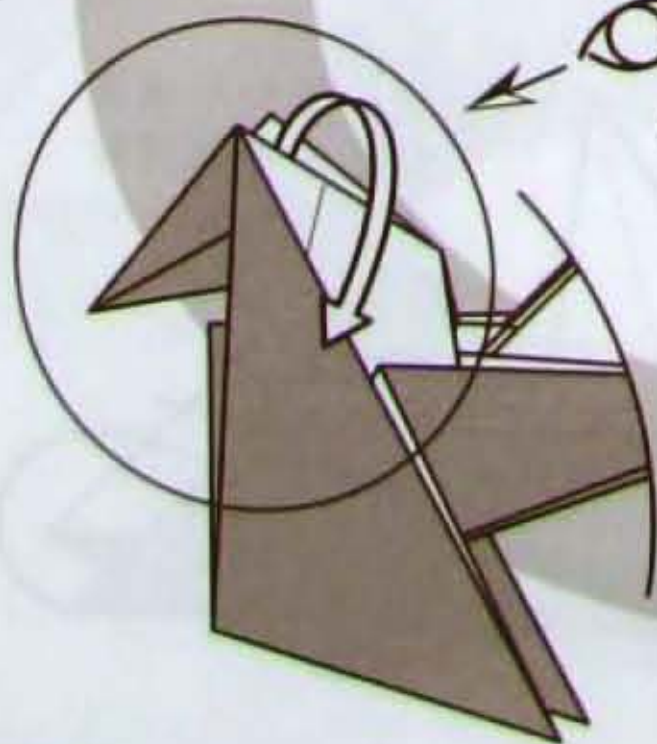

(開いて内側を見る)

33.

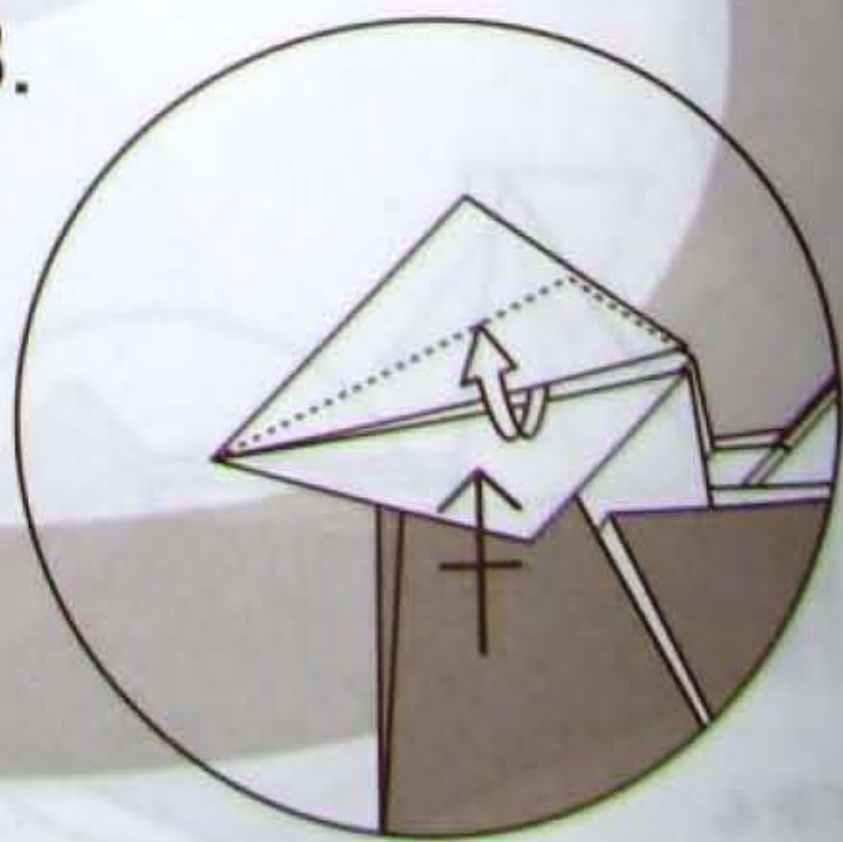

内側のカドを引き出す
反対側も同じ

36.

中割折りでカドを中に入れる
反対側も同じ

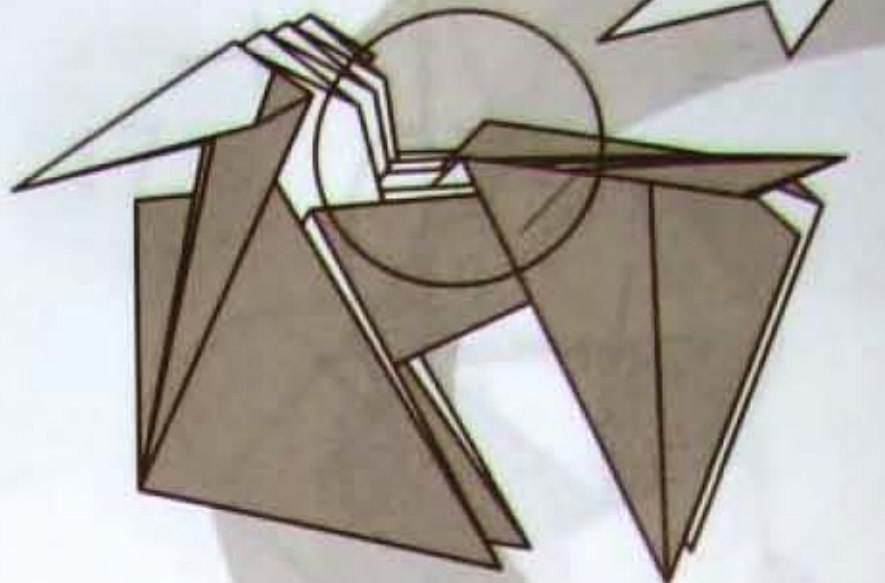

35.

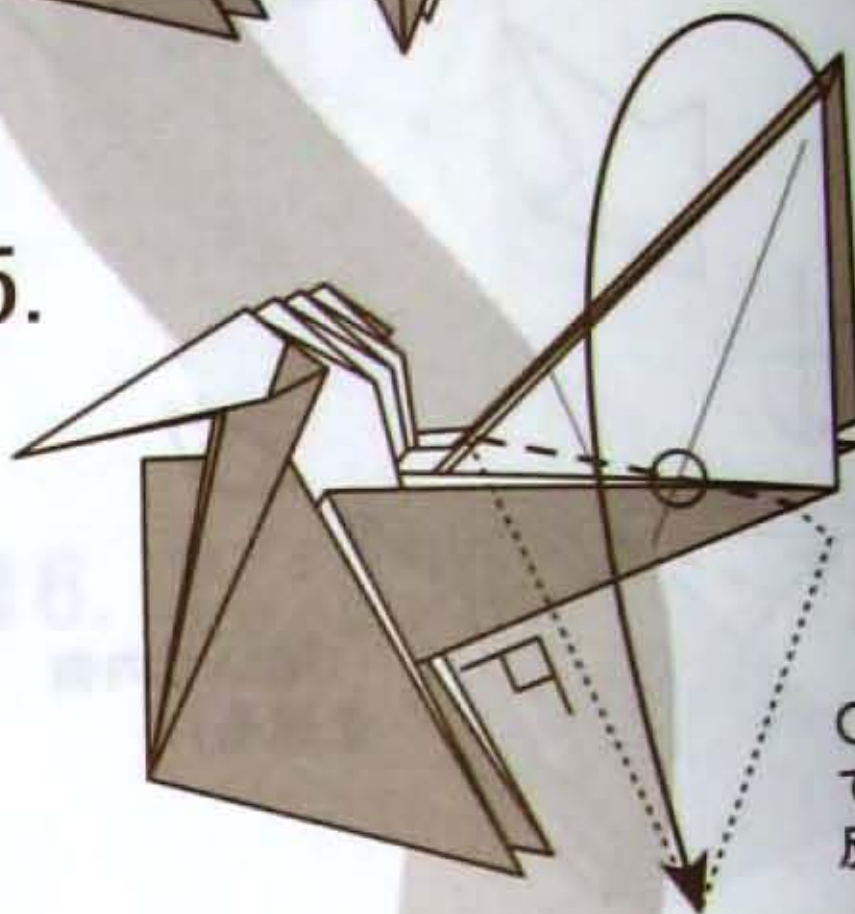

○印の交点を通る線で折る
反対側も同じ

34.

後ろの縁に合わせて引き寄せるように折る
反対側も同じ

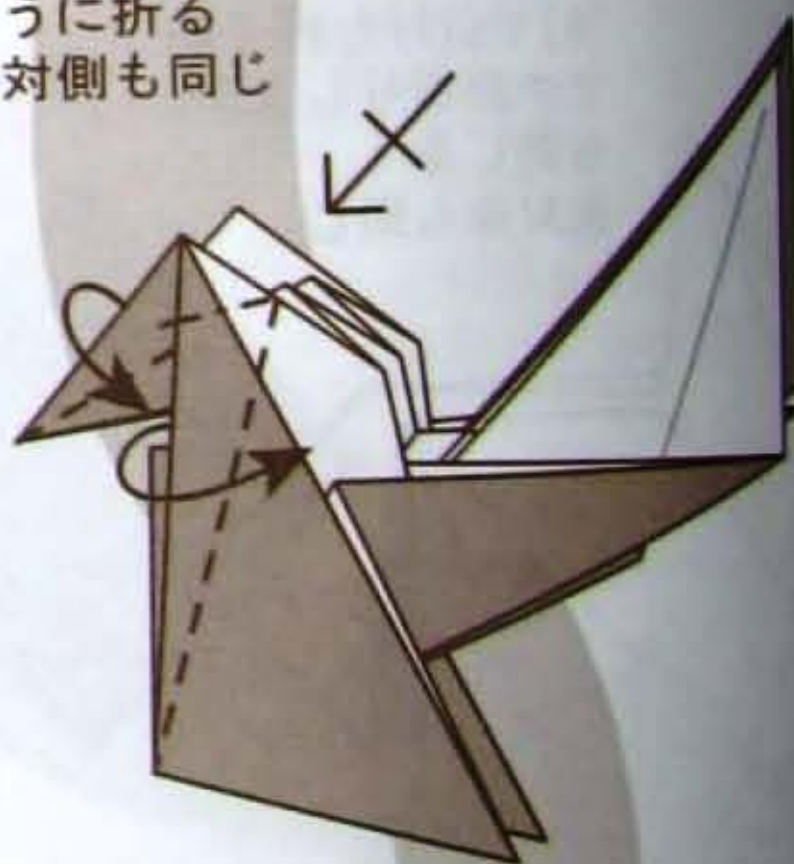

37.

38.



39.

40.

37.

●印を合わせるように
後ろへ折る



45.

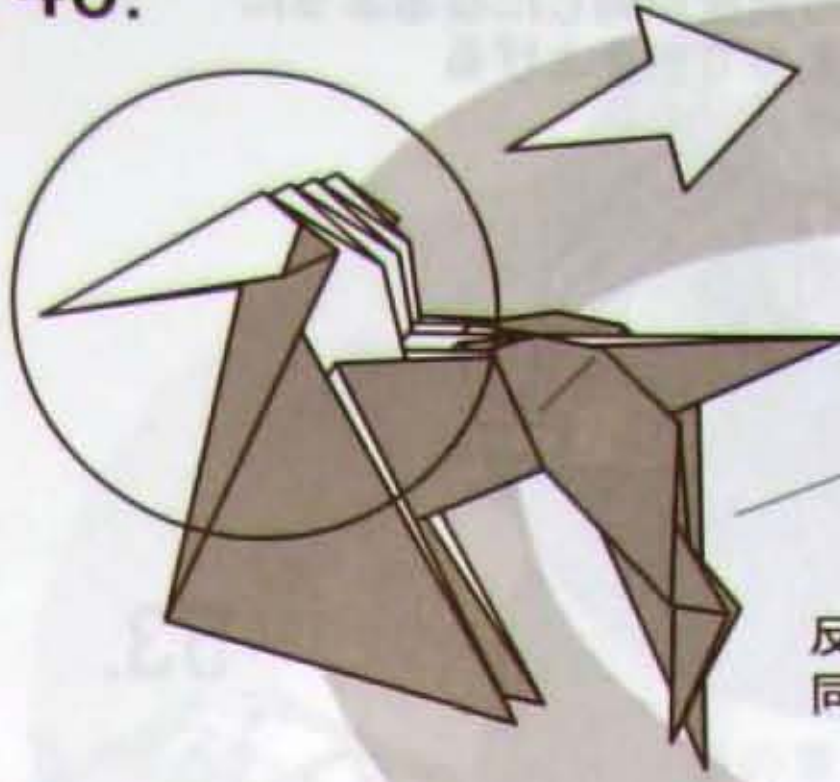

43-44

反対側も[43~44]と
同様に折る

38. 中割り折りで中に入れる
反対側も[37~38]と同様に折る

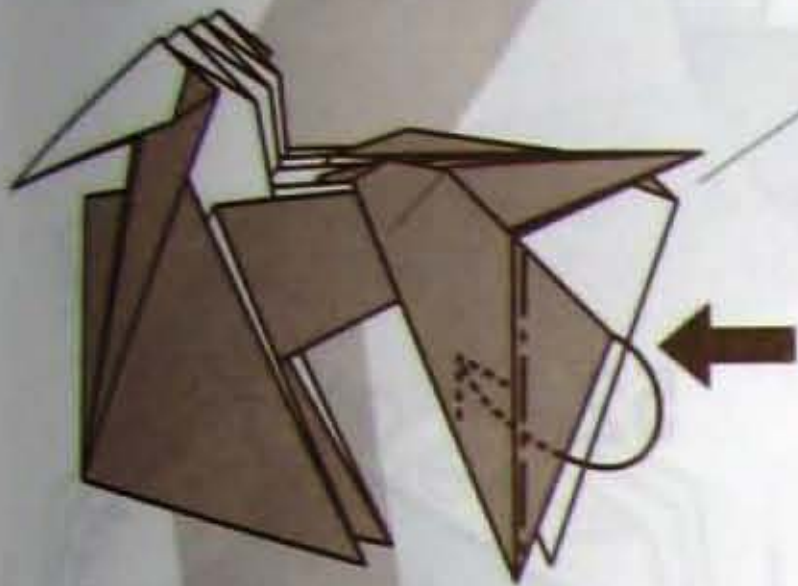

37-38

44. 中割り折り

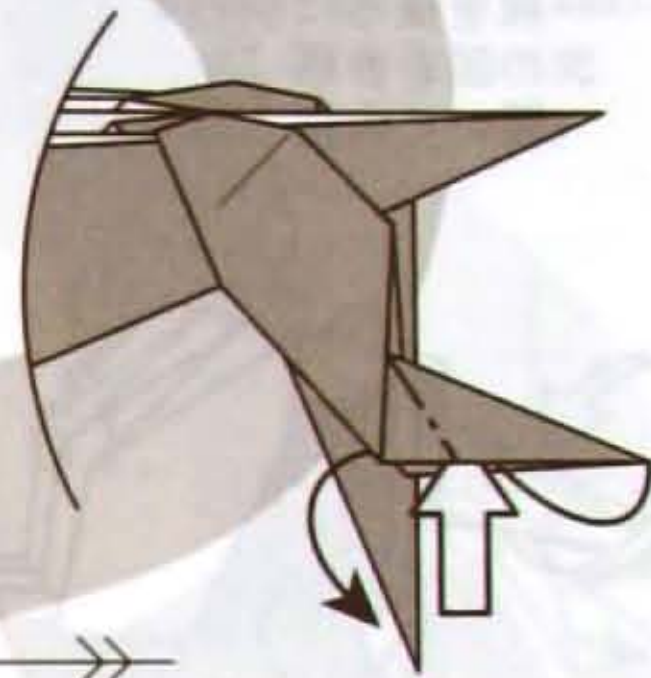

43.

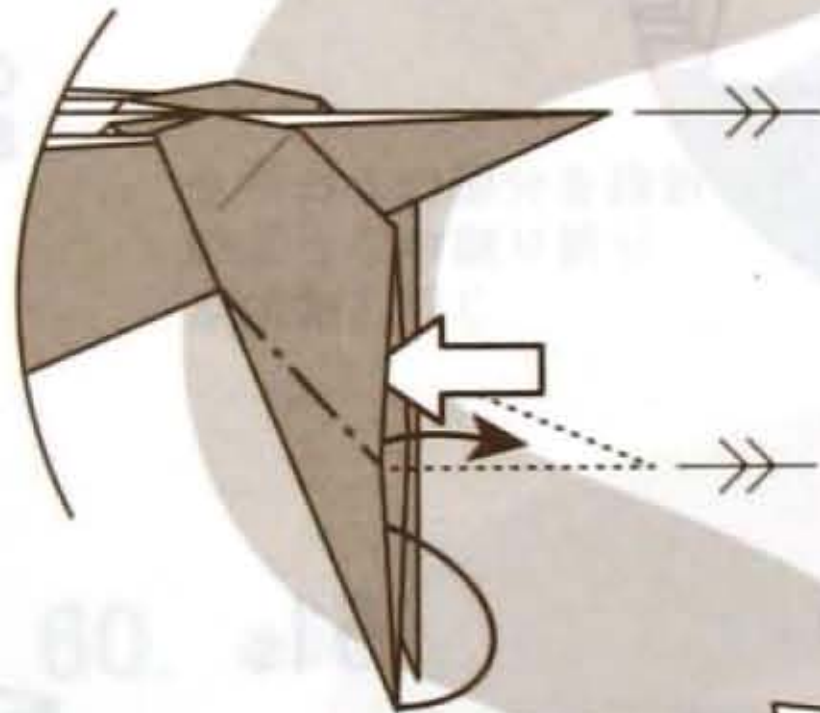

図の位置になるように
中割り折り

39.

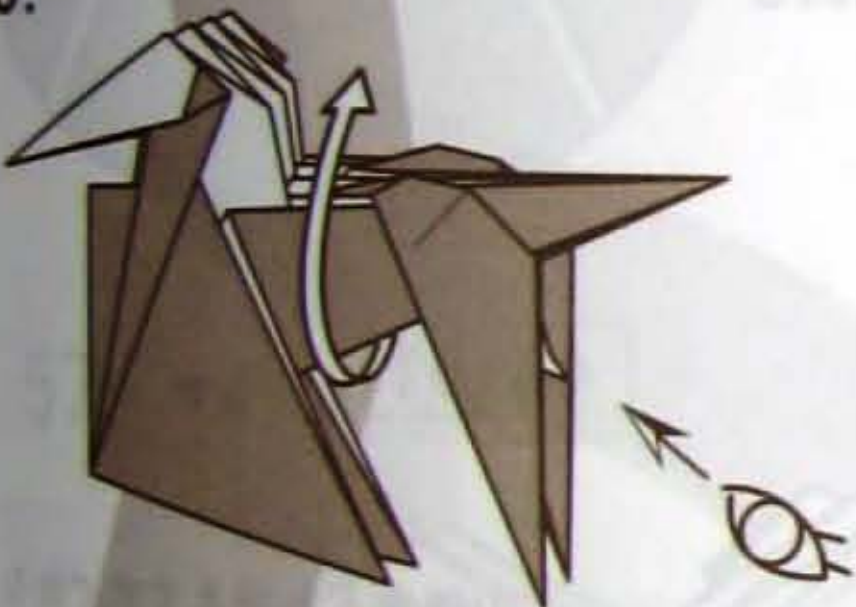

(開いて内側を見る)

42.

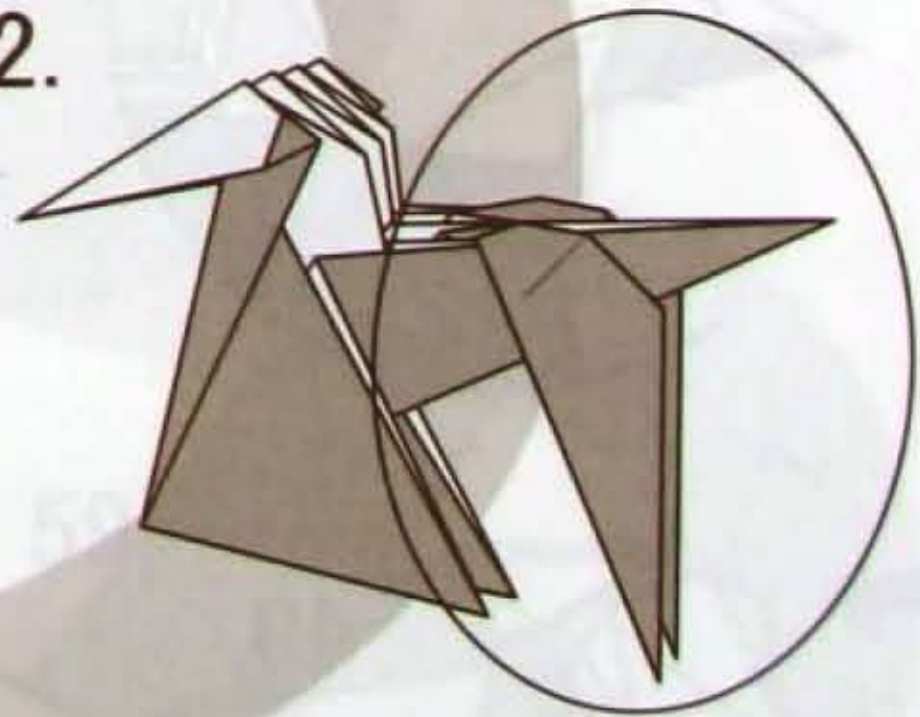

40. 中割り折りで出来た小さな
カドを隙間に差し込む
反対側も同じ

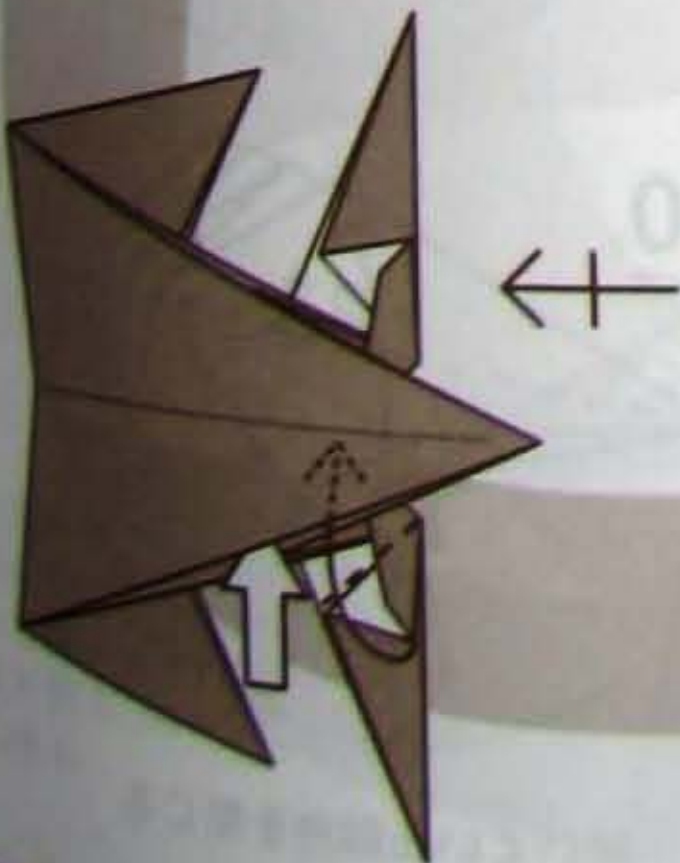

41.

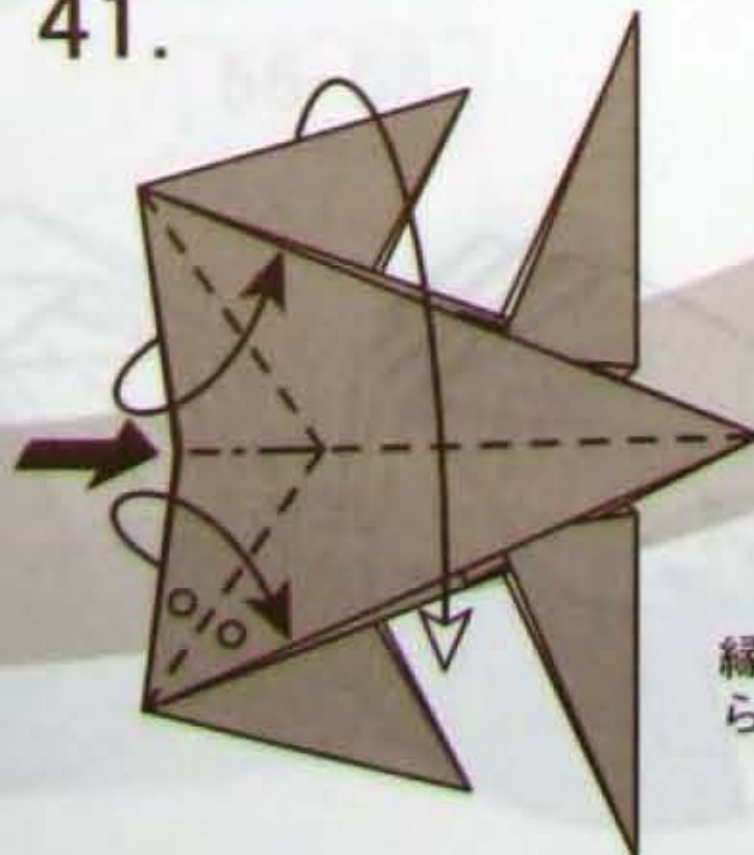

縁を合わせて折りなが
ら全体を閉じる

46. ○印部分の角度が同じになるように
カドをつまんで引き上げる

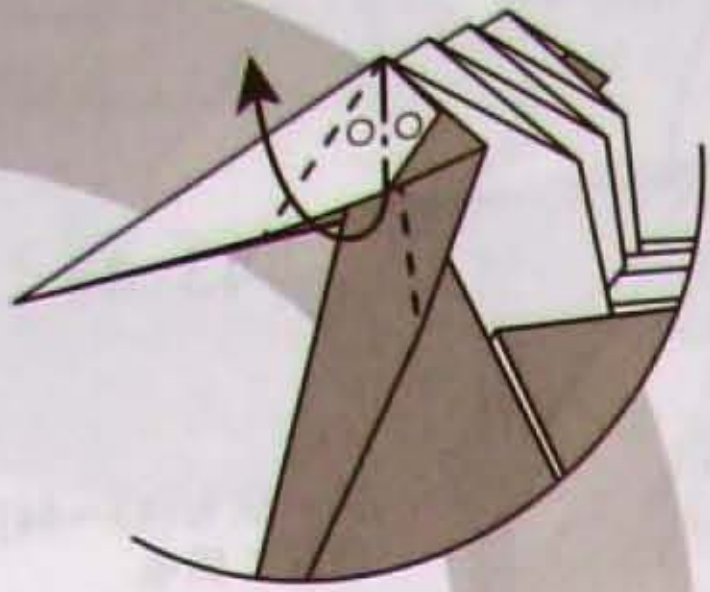

47. 山谷を入れ替えて手前の
一枚を後ろにまわす
次の図を参照
(開いて内側を見る)

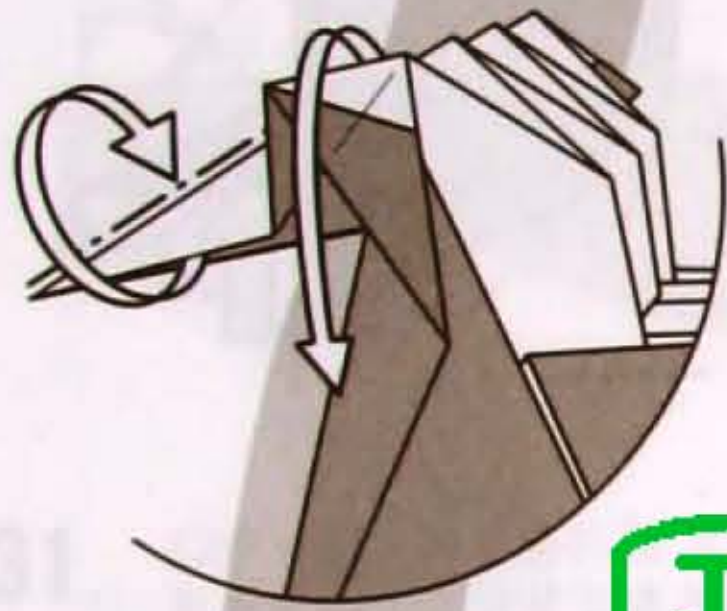

48. 縁を合わせて折る

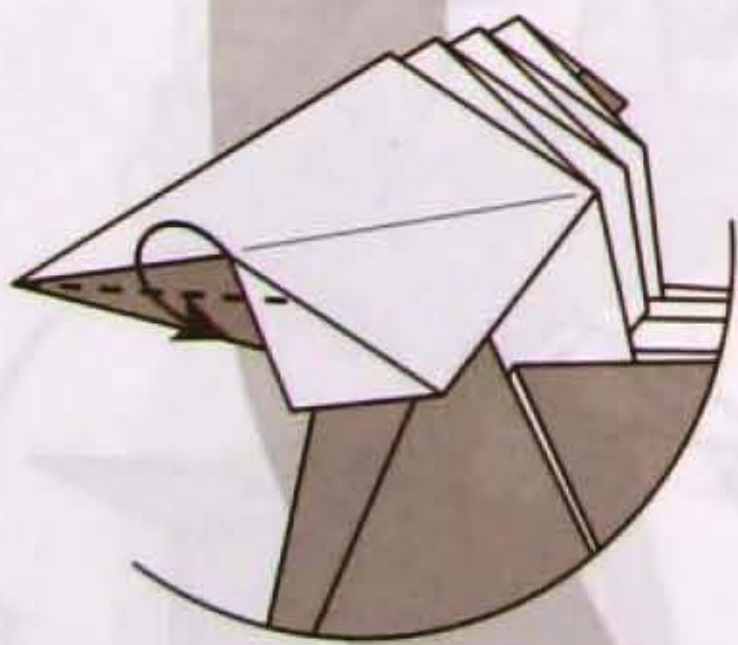

49. いっぱいのところまで
紙を引き出す

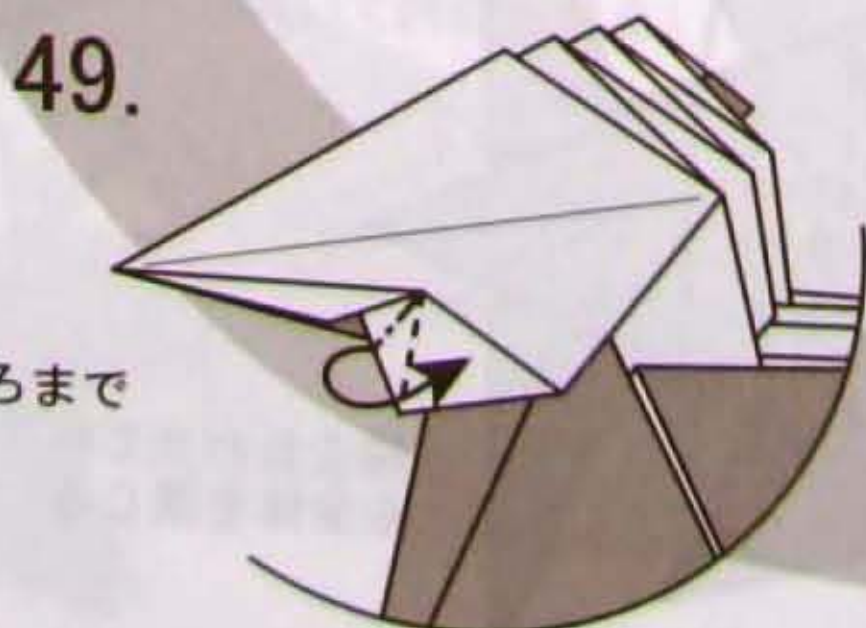

53.

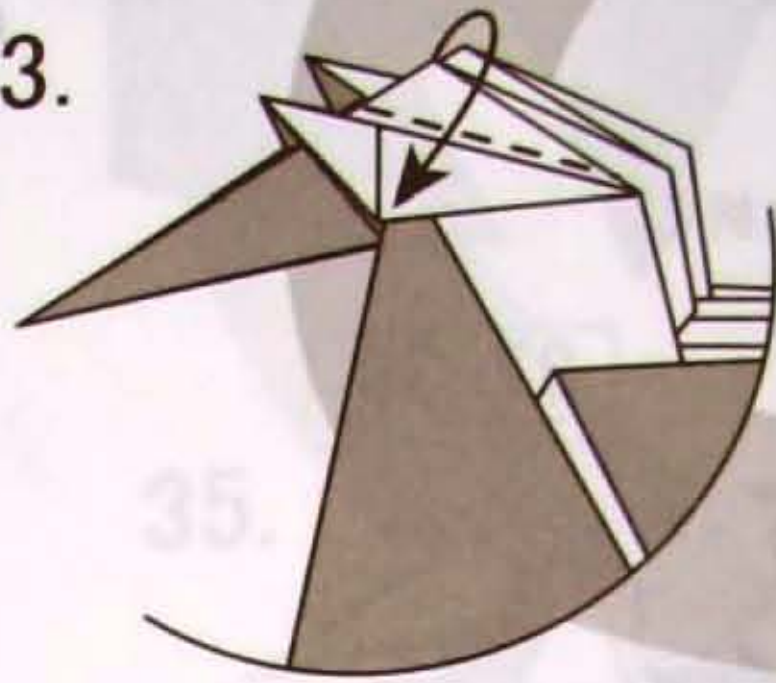

ポケットの奥の引
つかかるところか
ら折り返す

51.

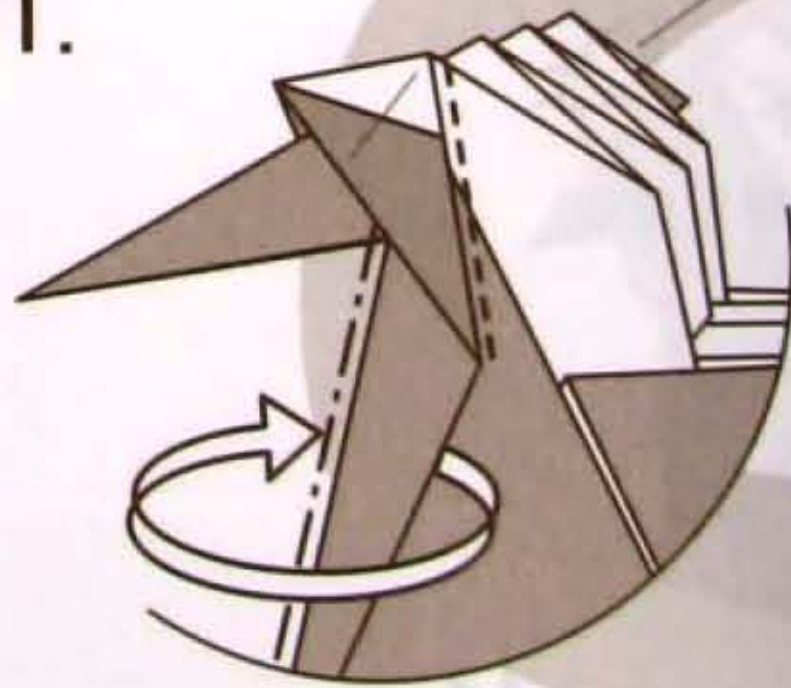

山谷を入れ替えてすぐ後ろ
の隙間に入れる
反対側も [46~51] と同様に
折る

54.

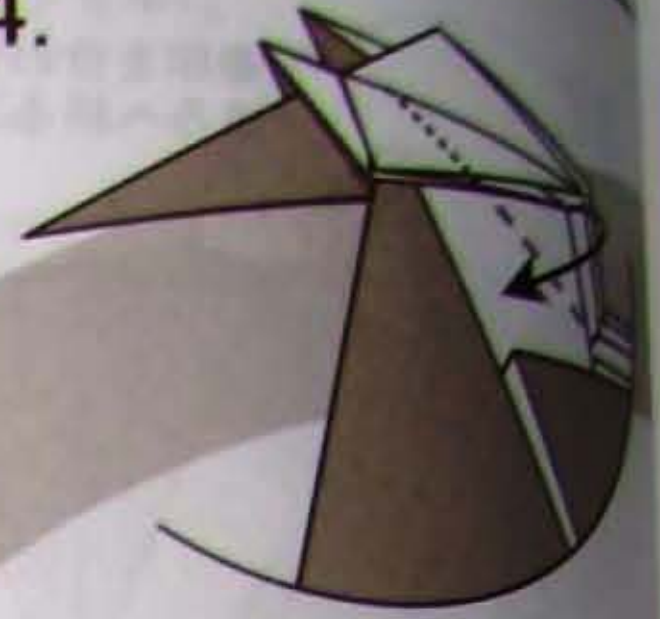

次のカドも手前と同
じ位置で折る

52.

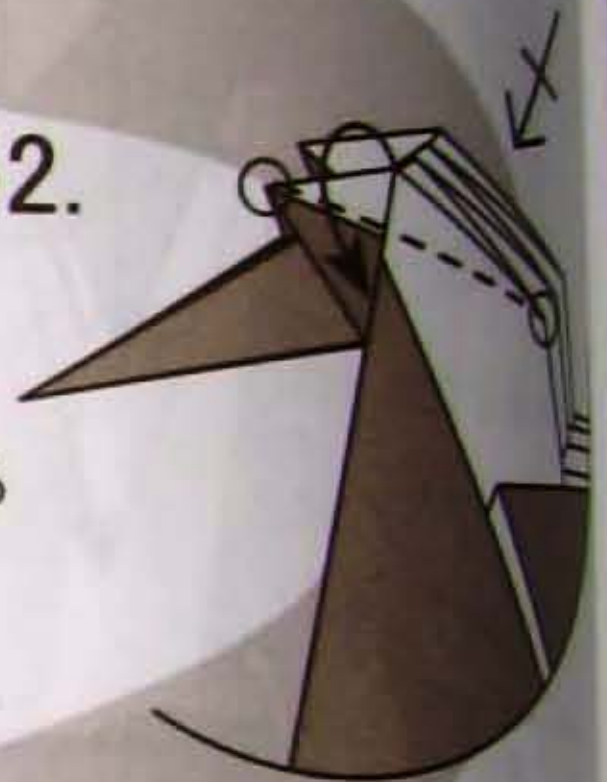

○印を結ぶ線で折る
反対側も同じ

50.

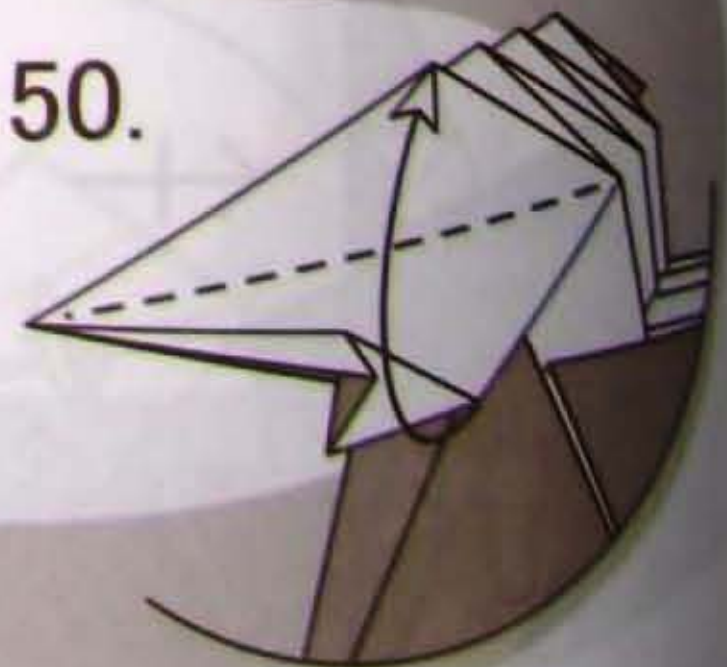

開いていた部分を閉じる

Japão Burajirujin

www.japaoburajirujin.blogspot.com

46-51

上の方 [54] で
折って折
反対側
に折る

第17回折紙探

53-54

55.

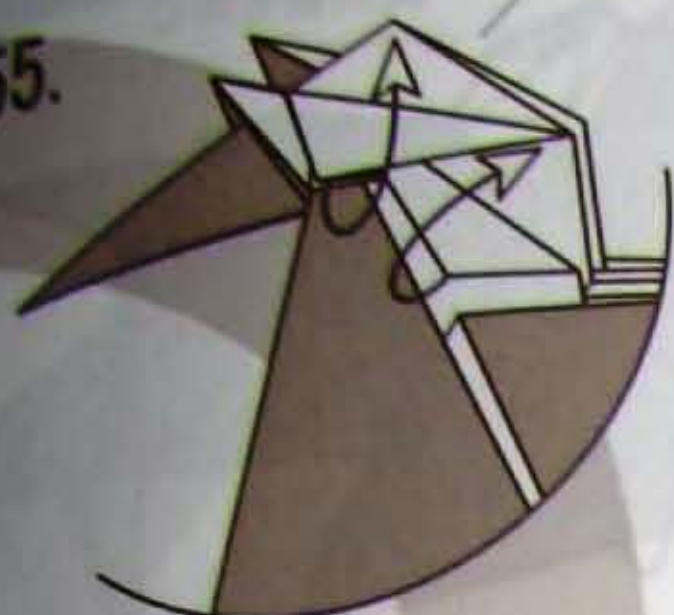

反対側も [53~54] と同様に折り筋を付ける
しっかりと折筋を付けたら [53] の状態に戻す

56.

○印 (緑と折り筋の交点) を
基点に耳を下へ折る

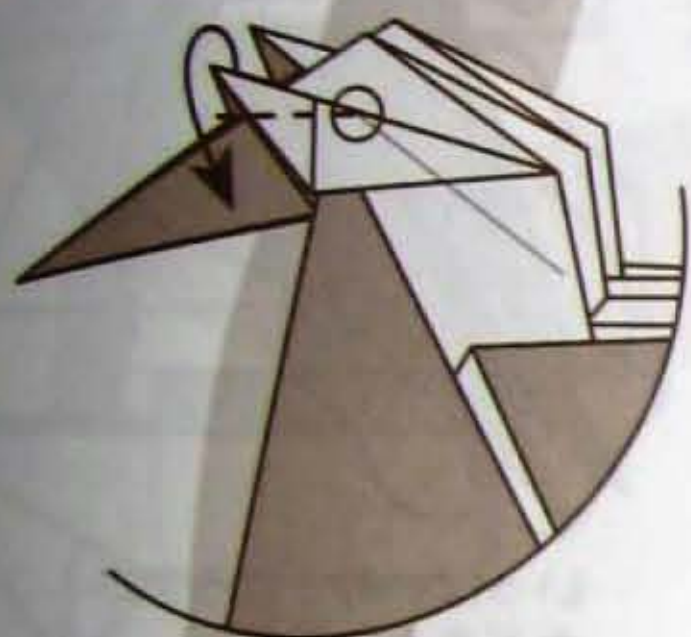

57.

手前と同じ位置で折る

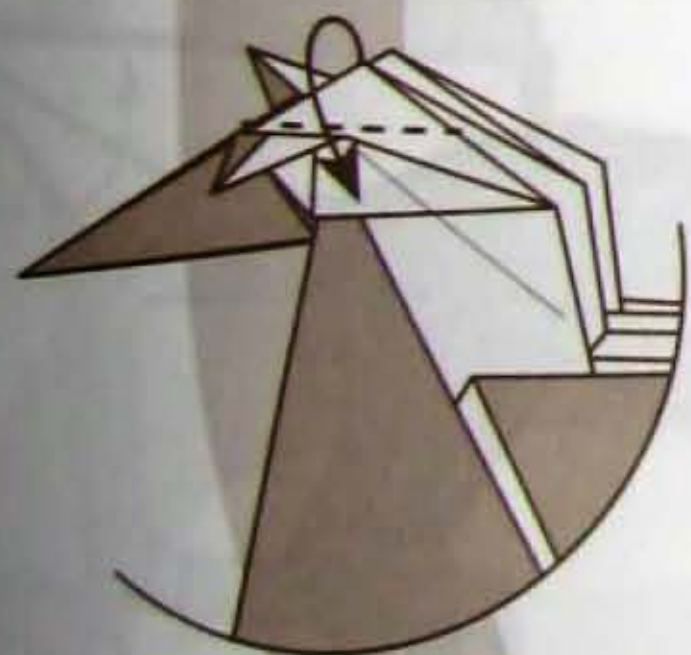

58.

上の方を段折りしながら
[54] で付けた折り筋を使
って折り返す
反対側も [56~58] と同様
に折る

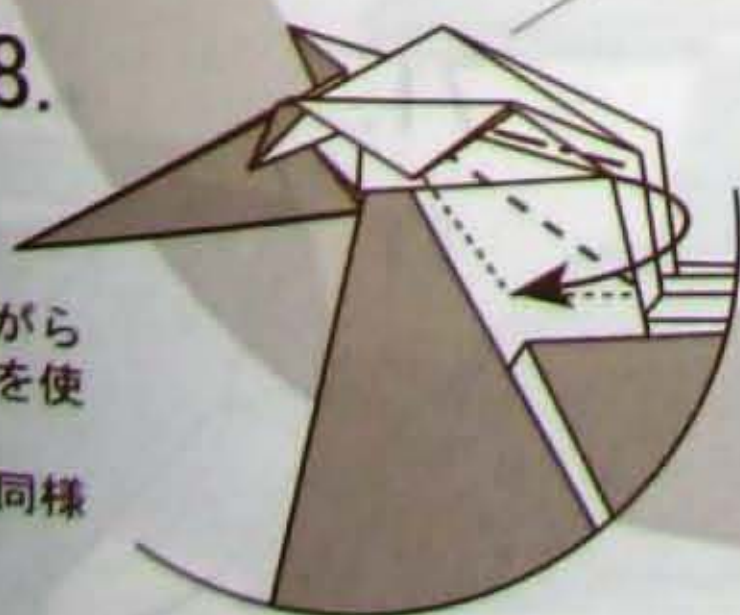

62.

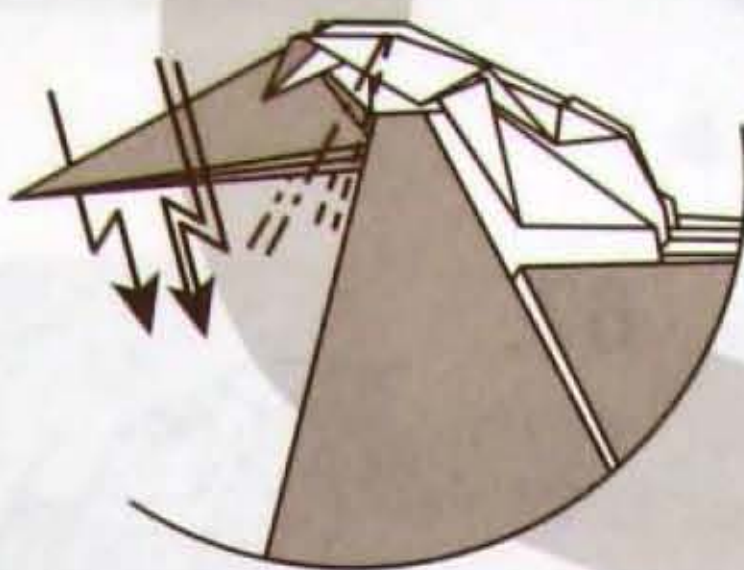

紙の重なりをそのまま保ち
ながら、頭の部分を段折り
で下に向ける
(頭の部分が3層になってい
るので、1枚と2枚に振り分
ける)

61.

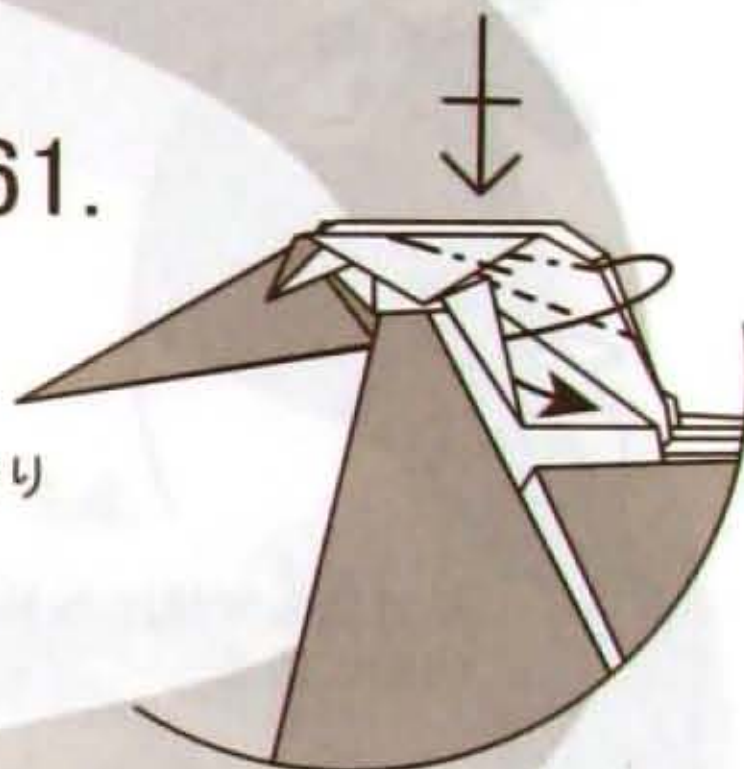

タテガミの部分を段折り
のような中割り折り
反対側も同じ

60.

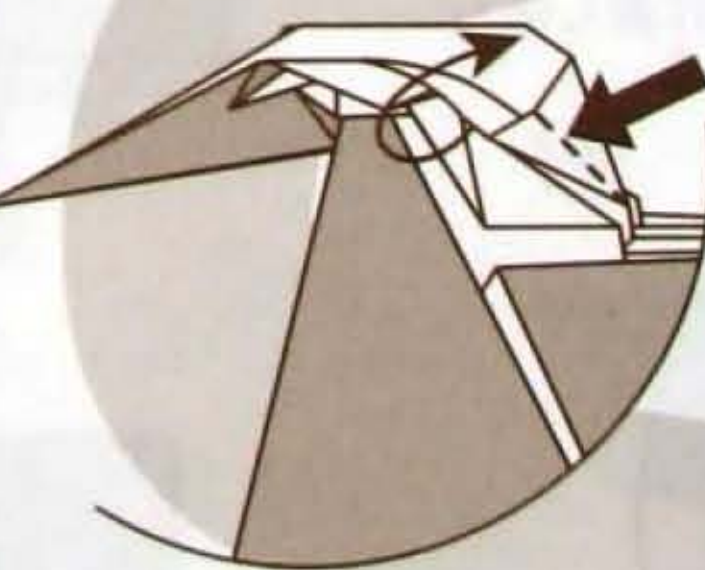

56-58

59.

中央のカドを開いて
つぶす感じで中に押
し込む

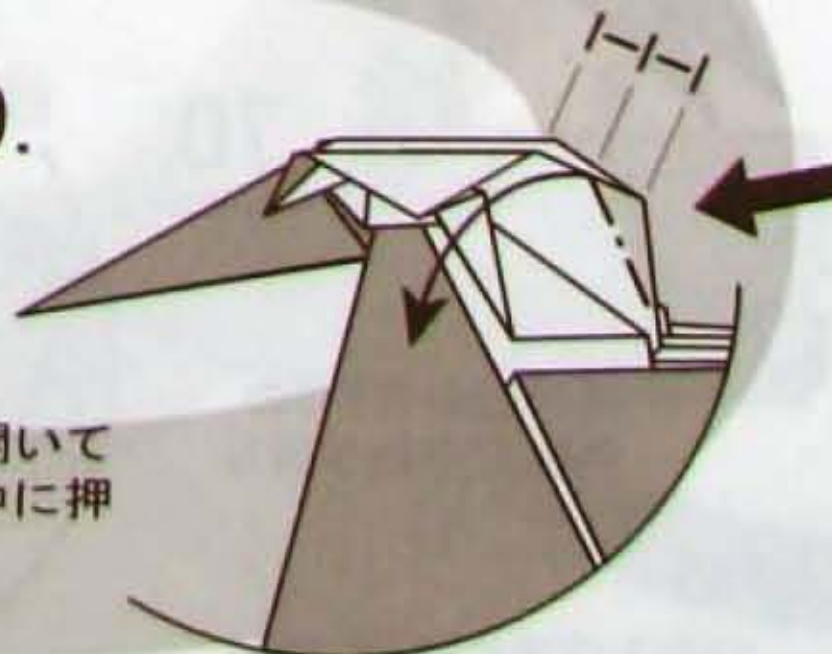

64.

耳を立てながら円錐形に膨らませて立体化する
反対側も同じ



65.

前足をつまみ折り
反対側も同じ

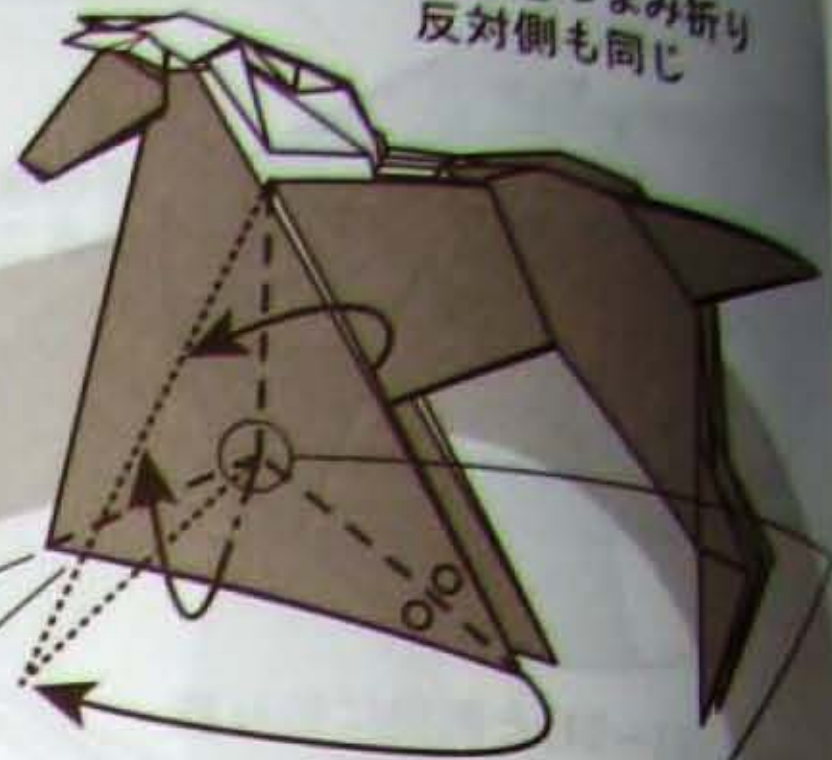
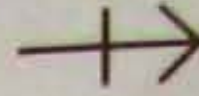

ここは少し隙間が空く

後ろにある胴体の端と一致する位置で折る

67.



前足の部分を透視

66.



いっぱいのところまでカドを上折る
(次の図を参照)

68.



反対側も同様にカドを内側に折る

72. 完成

69.

[41]で折ってできた内側にあるカドを隙間に差し込んで開き止めにする

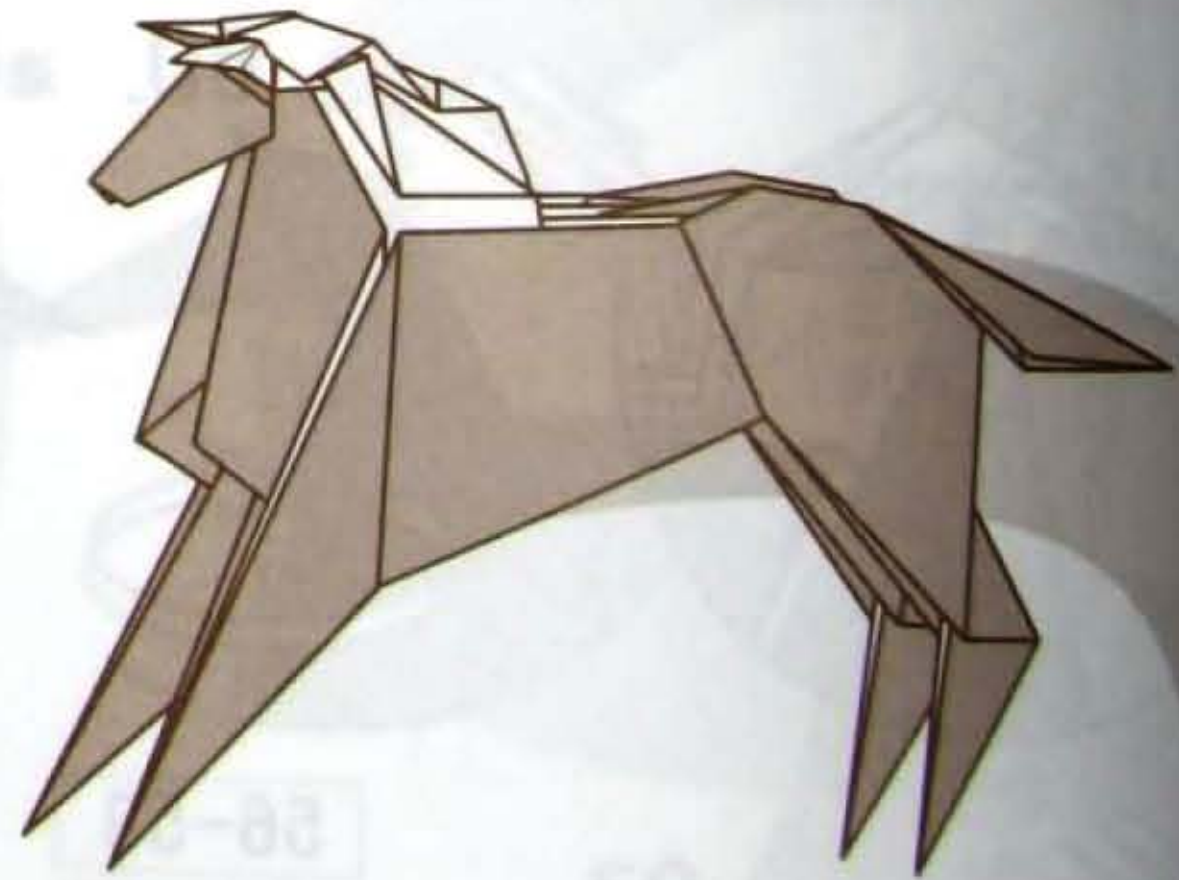

70.

尾の部分を1/3の角度で中割り折り

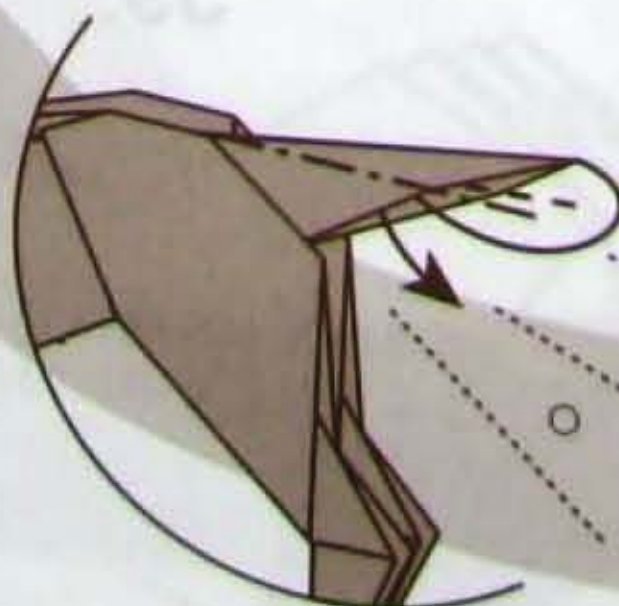

71.

カドを両側へ折り返す



イル

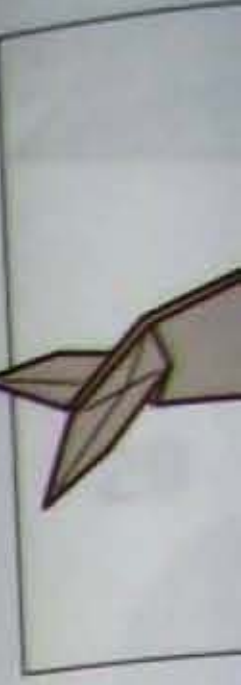

6

7

8

9

10

イルカ

創作 / 青木 良

風船基本形を折って
はじめます

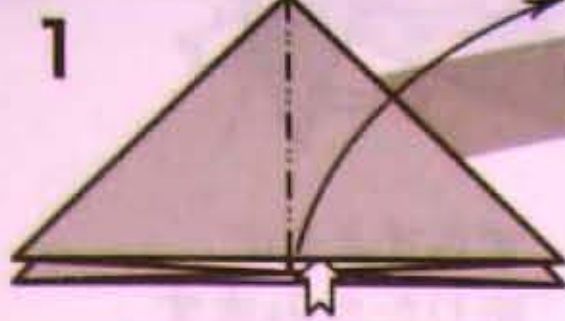

もどします

2

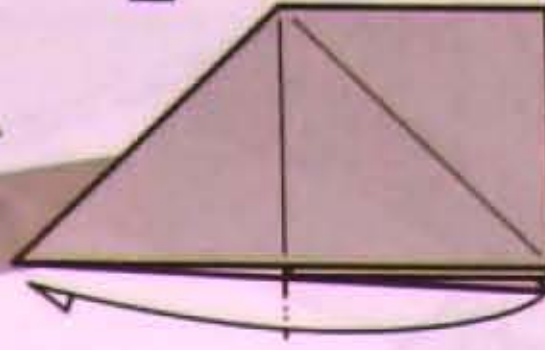

3

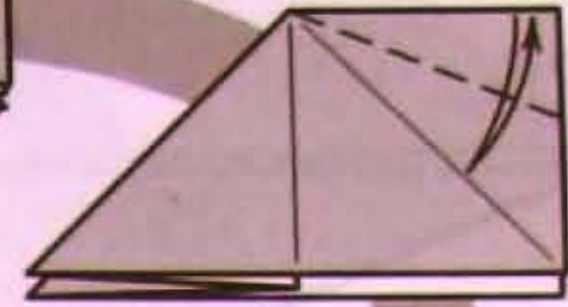

4

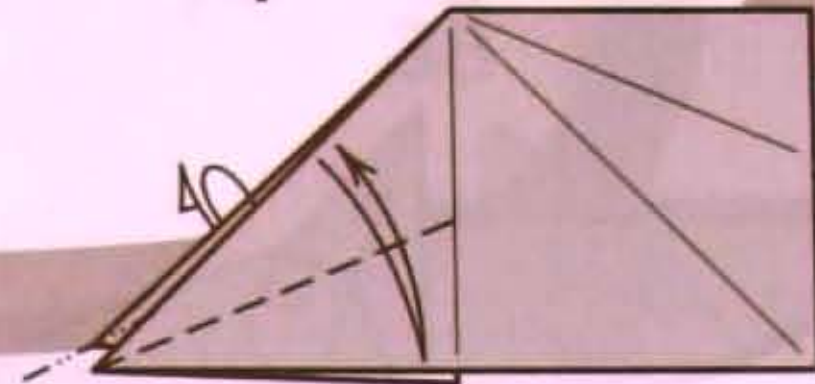

5

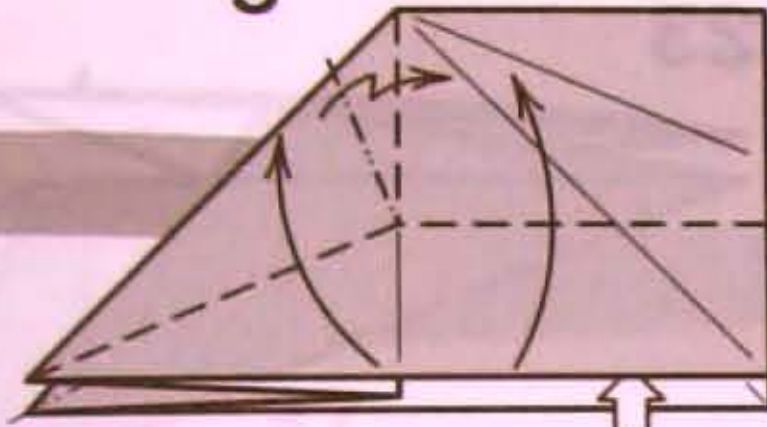

よせるように
折りたたみます

6

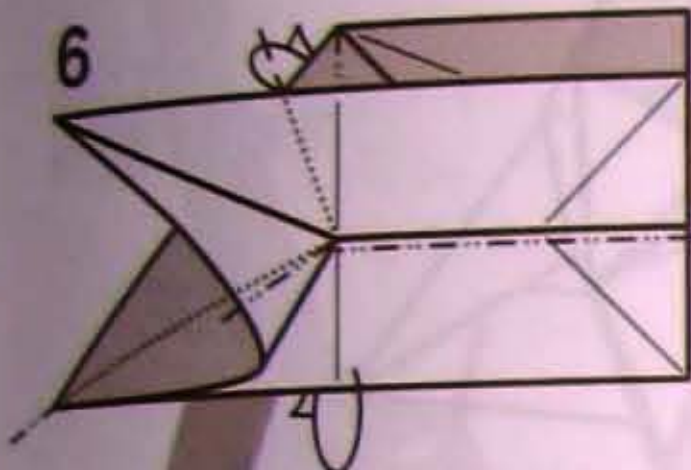

うらがわも同じ

7

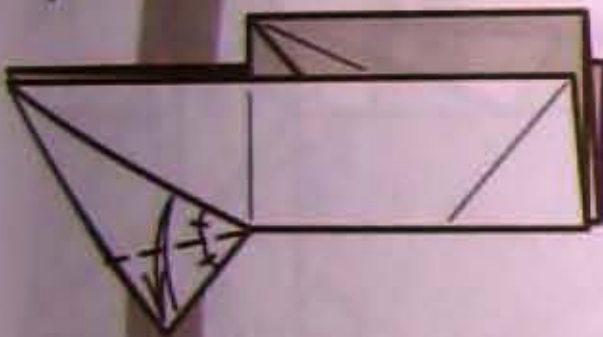

8



かぶせるように
折りたたみます

9



10



もどします

13

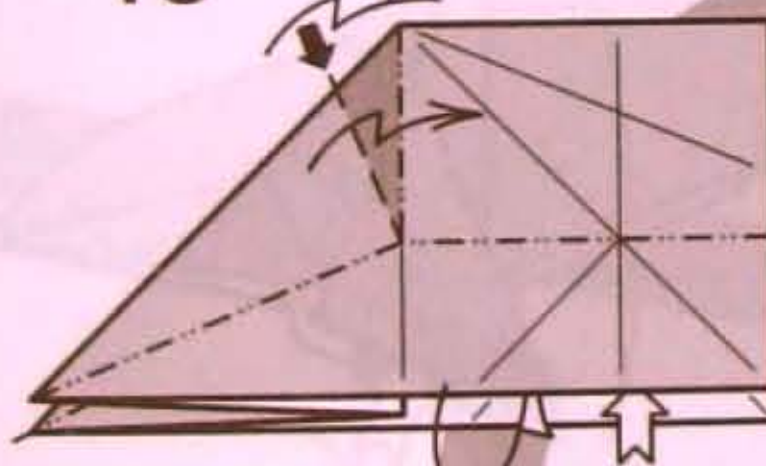

■の部分を
中に押し込むように
折りたたみます

12

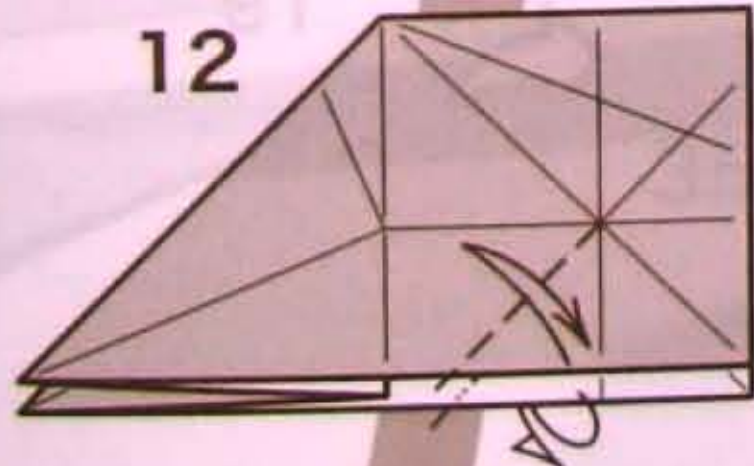

11

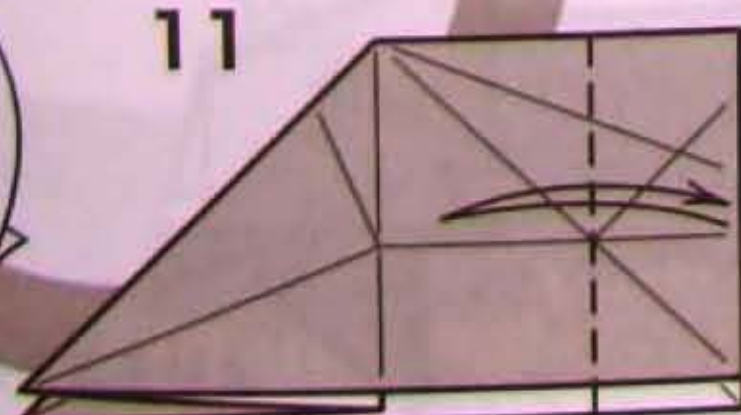

14

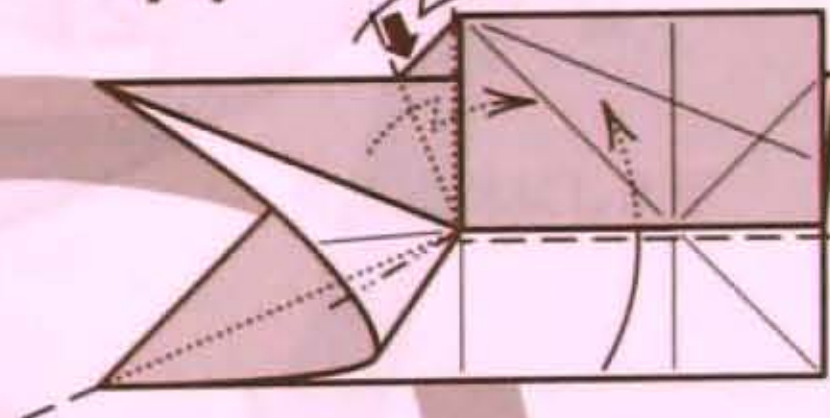

うらがわも同じ

15

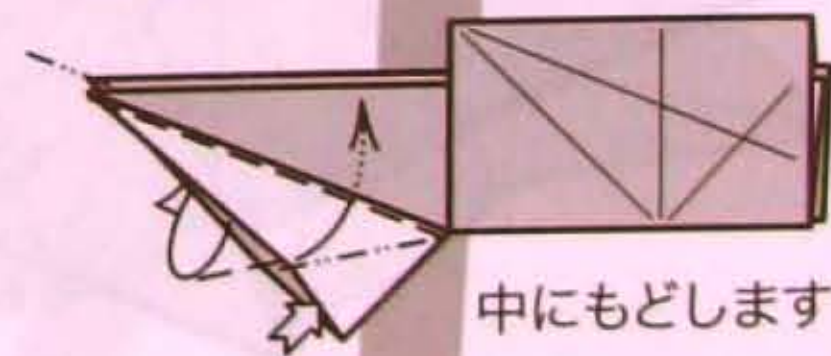

中にもどします

16

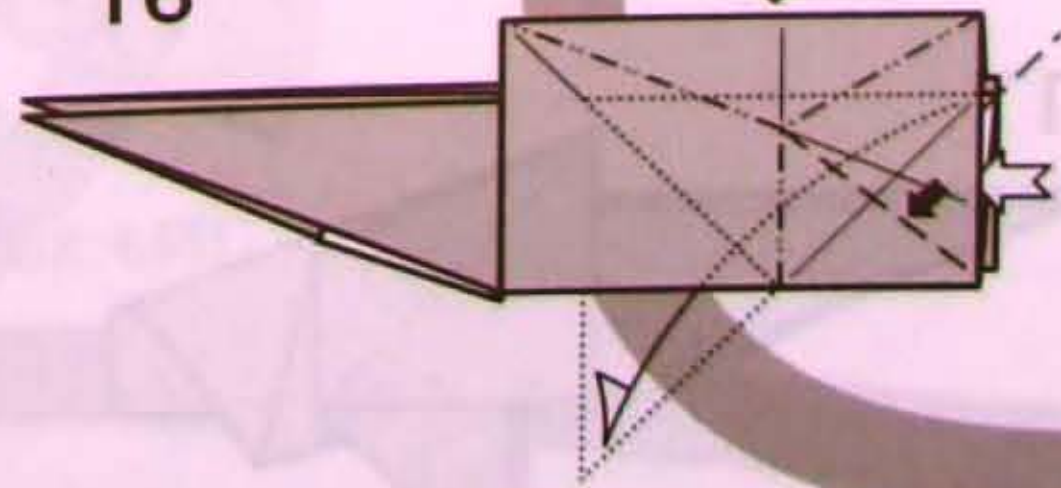

中の紙をつまむように
折りたたみます

Japão Burajirujin

www.japaoburajirujin.blogspot.com

27

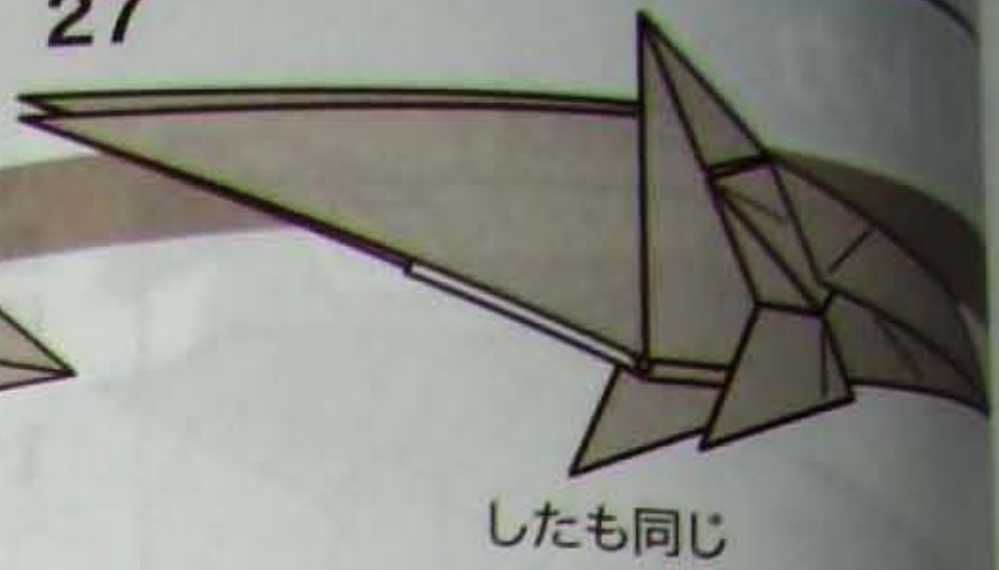

したも同じ

26

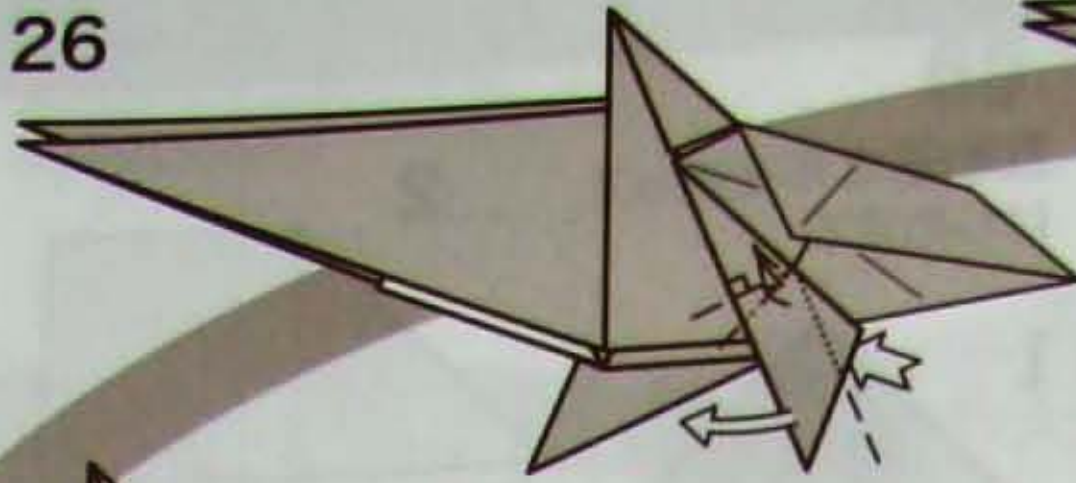

ずらすように
折りたたみます

25

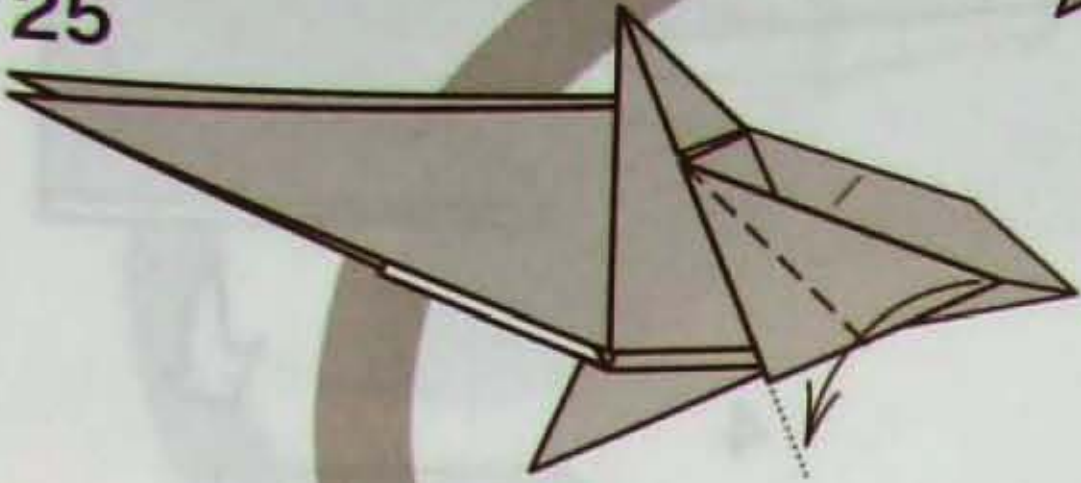

ずらすように
折りたたみます

24

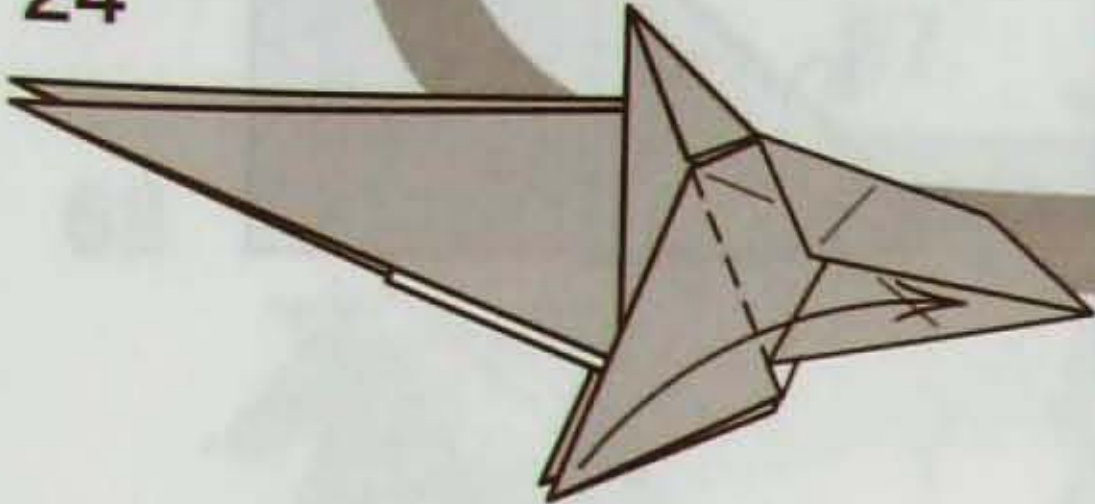

はんたいがわも同じ

23

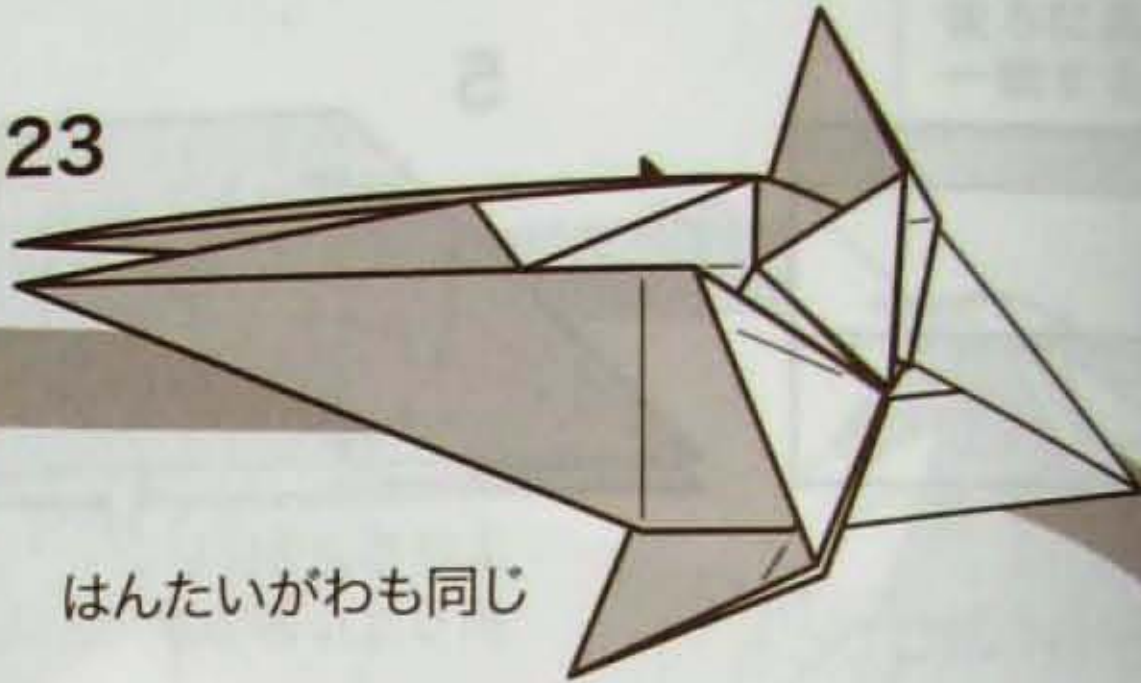

22

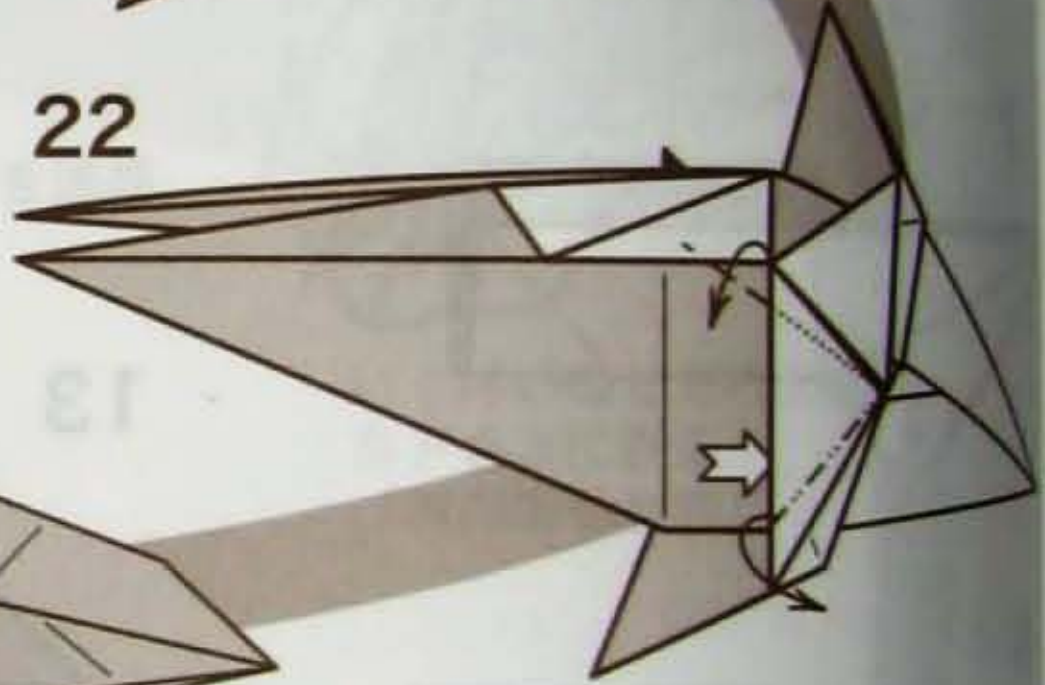

ずらすように
折りたたみます

21

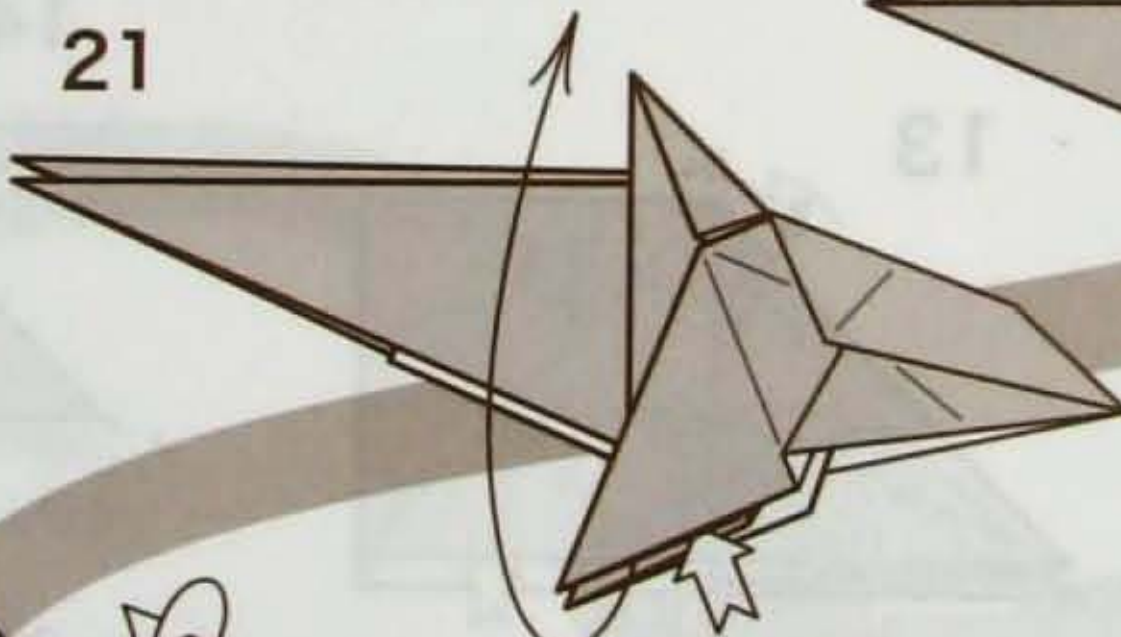

開きます

20

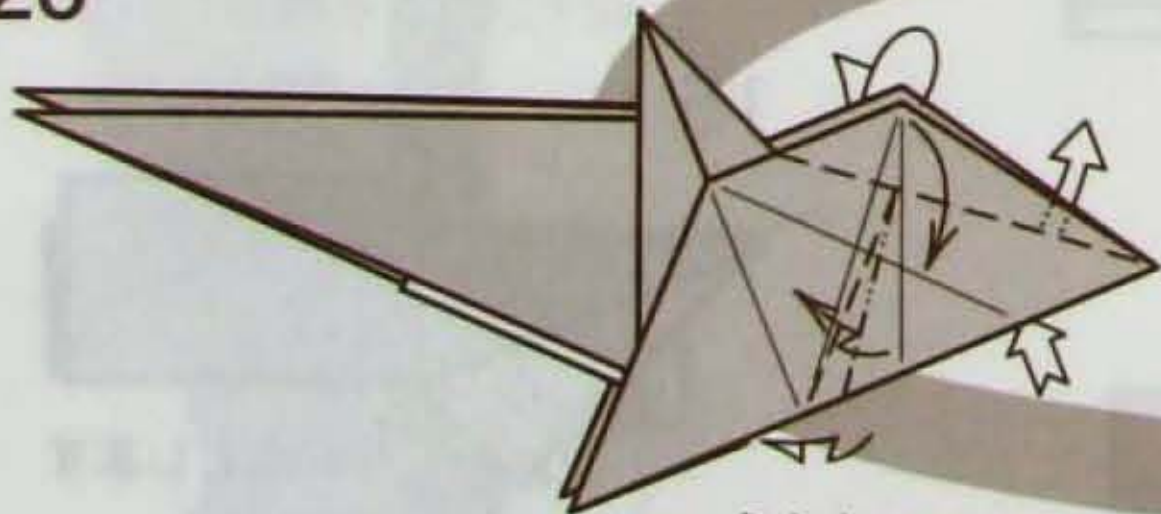

うらもいっしょに
ずらすように
折りたたみます

19

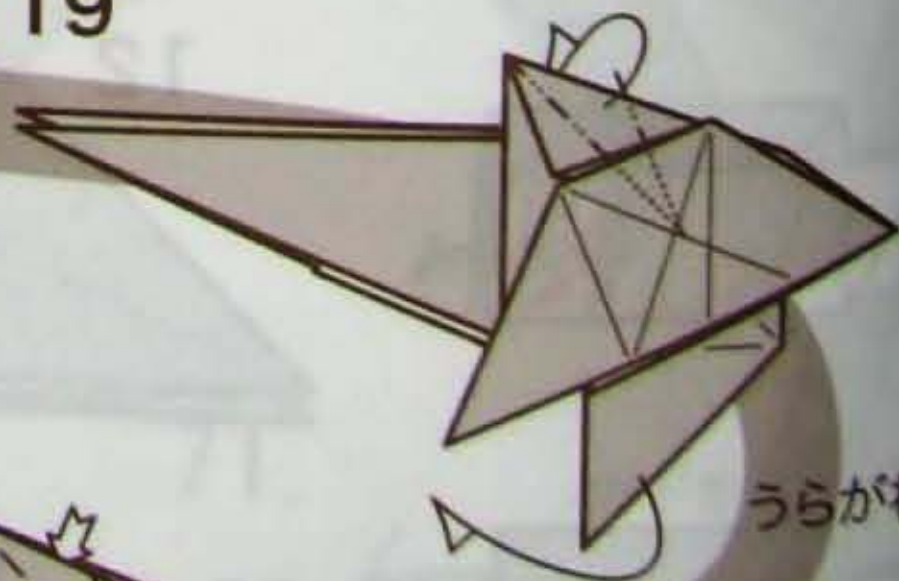

うらがわも同じ

17

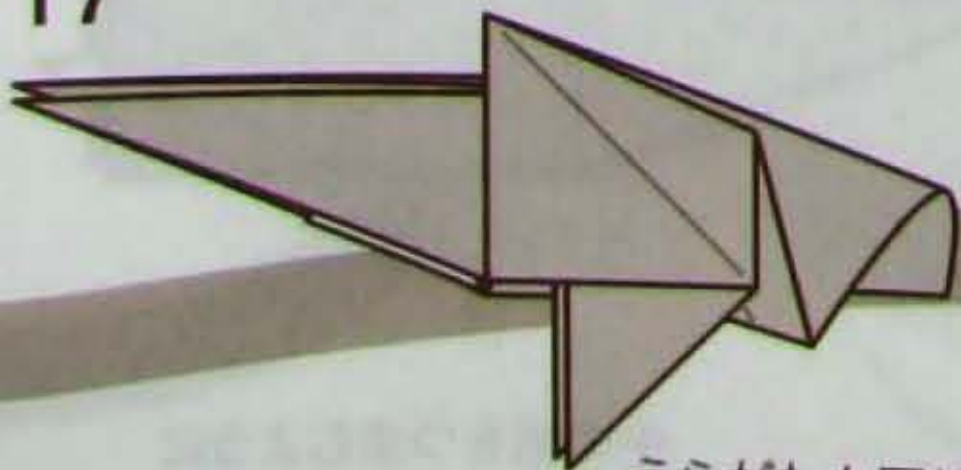

うらがわも同じ

18

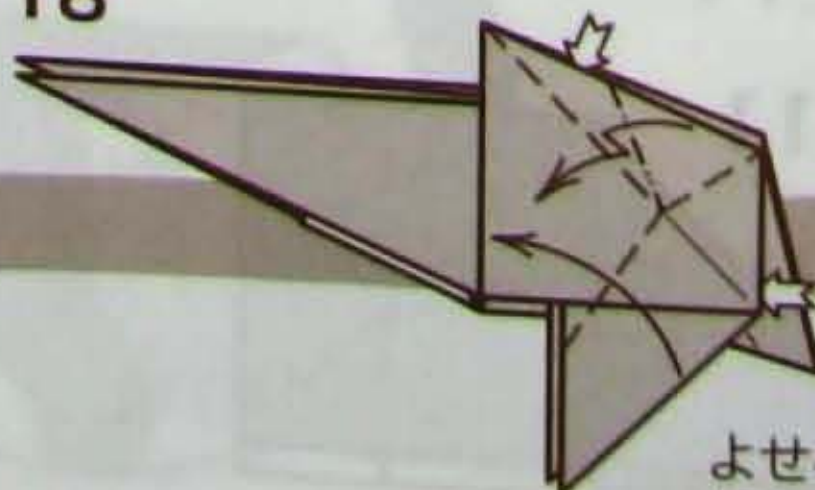

よせるように
折りたたみます

28



29



開いて
折りた

3

31



32



3

開
折

できあがり

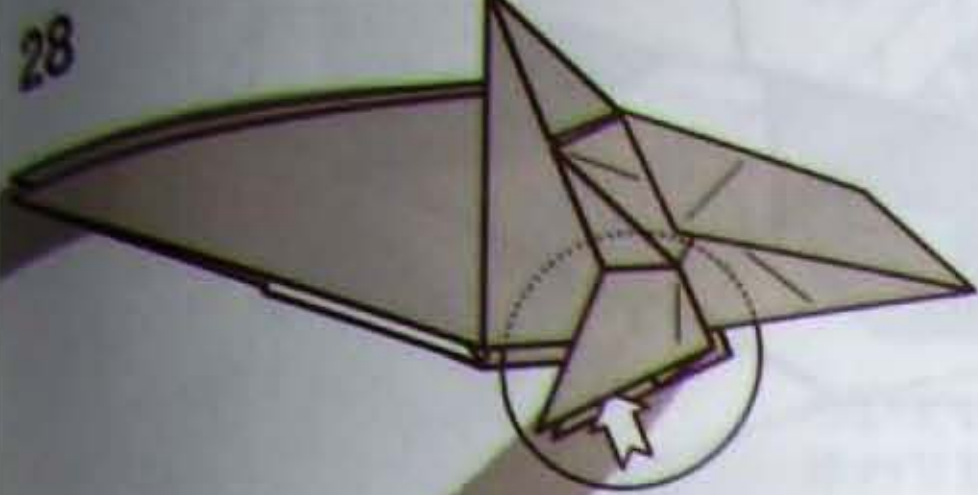

28

開きます



29

開いて
折りたたみます



30

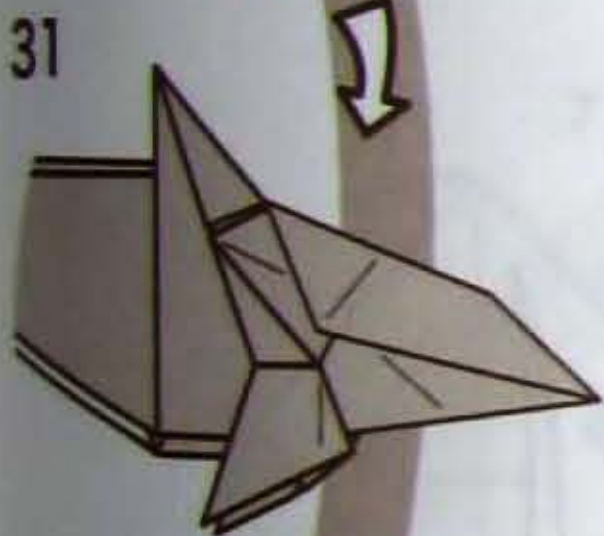

31

うえも同じ

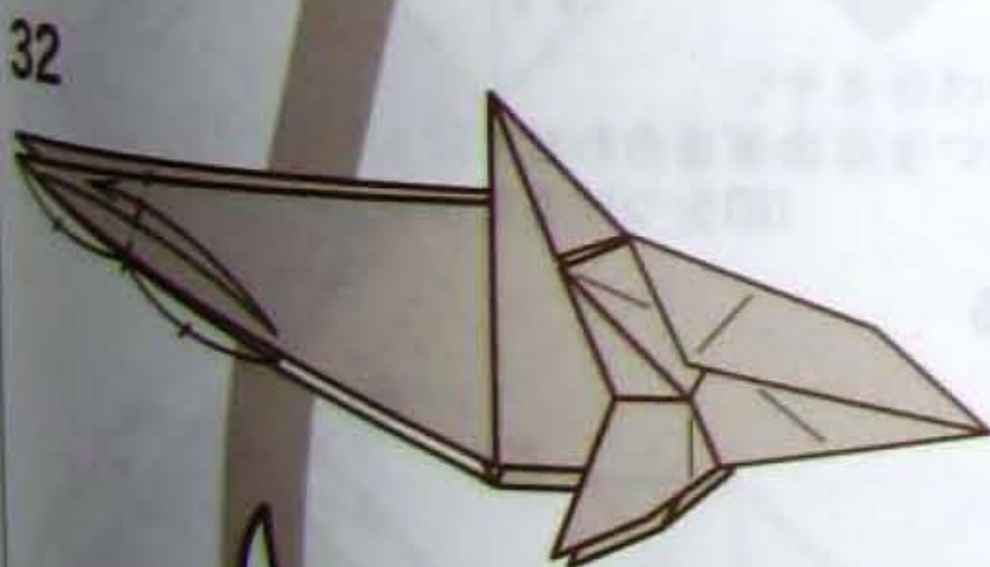

32



33

開いて
折りたたみます

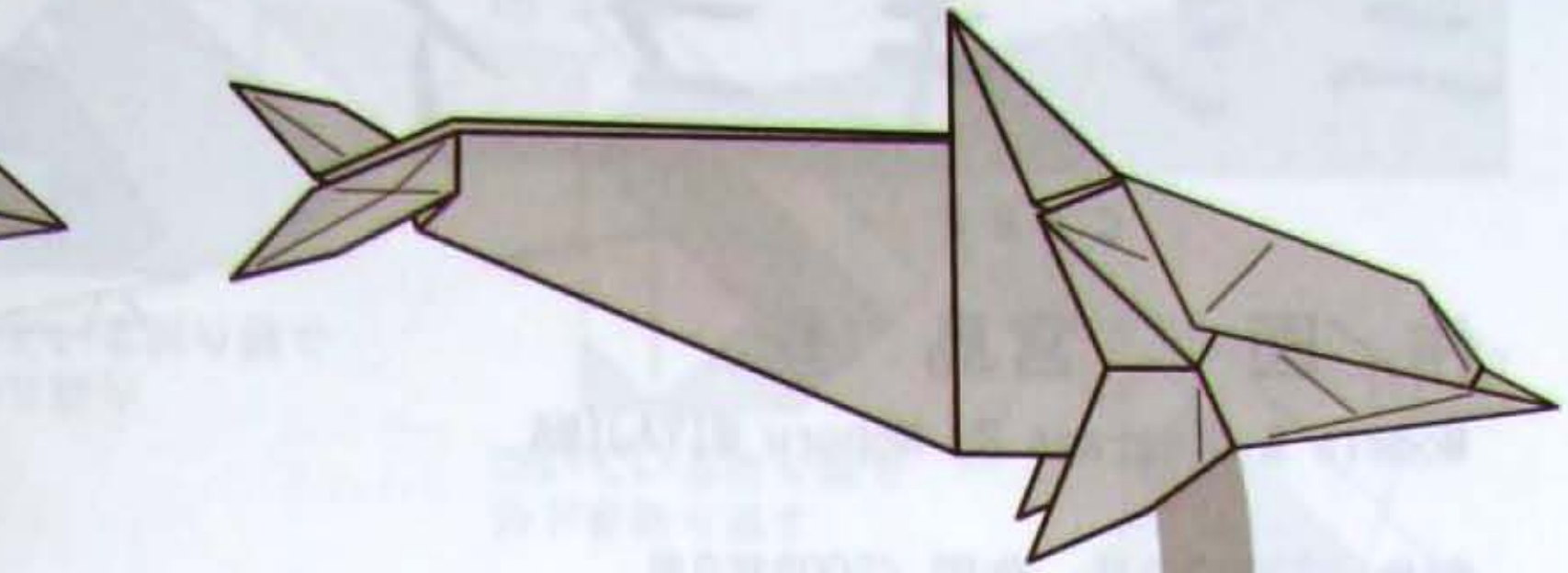

34

開いて
折りたたみます

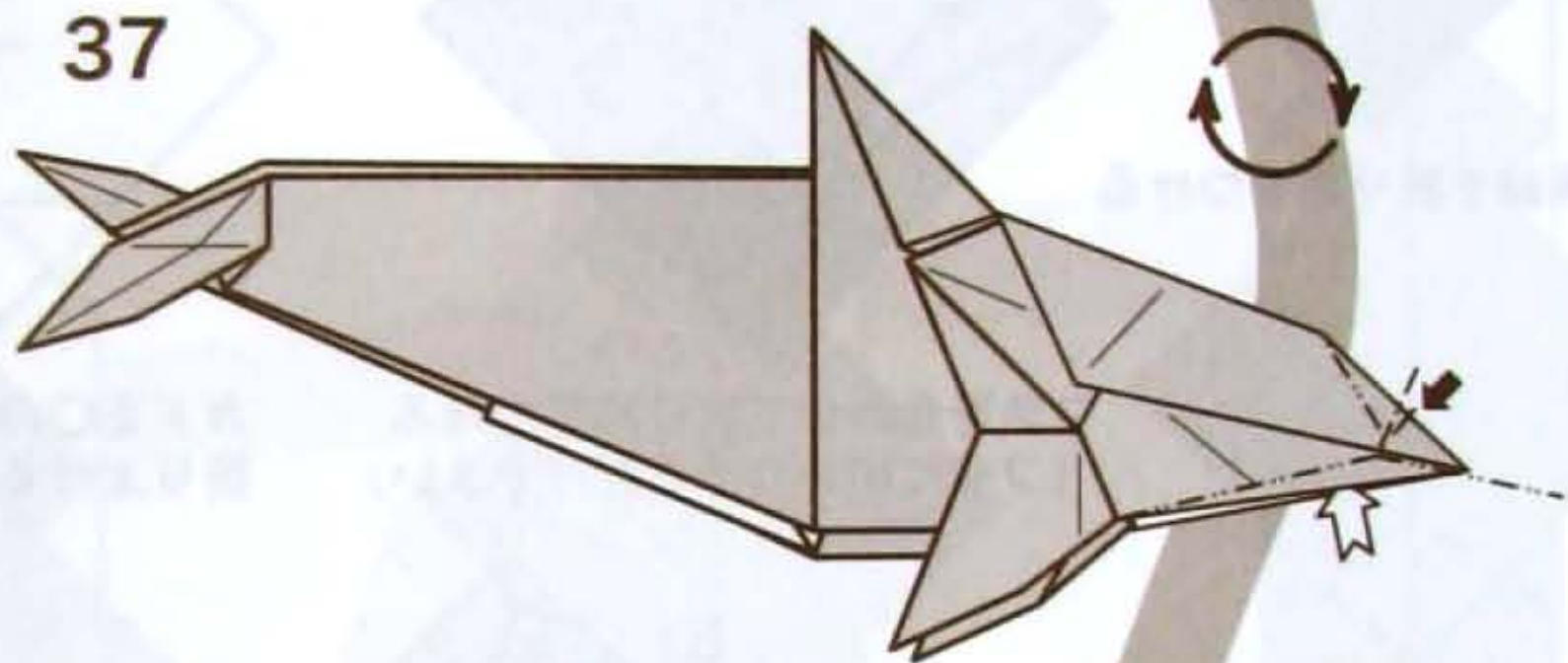

35

したも同じ

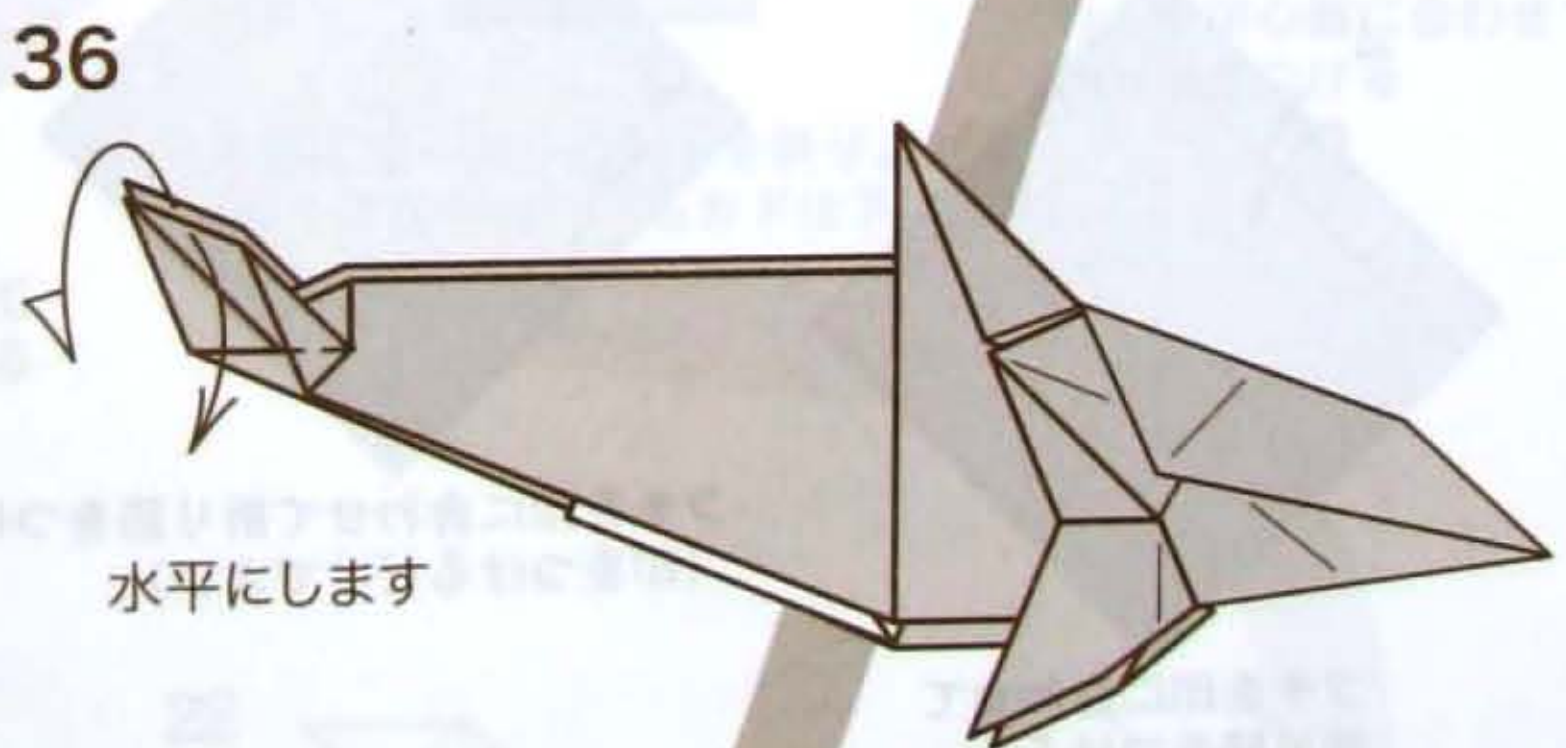

36

水平にします

38

先を立体にします



ニシキゴイ

CARP

作/図 宮島 登

Models & Diagrams By Noboru MIYAJIMA

創作 / 2009年2月 作図 / 2009年9月

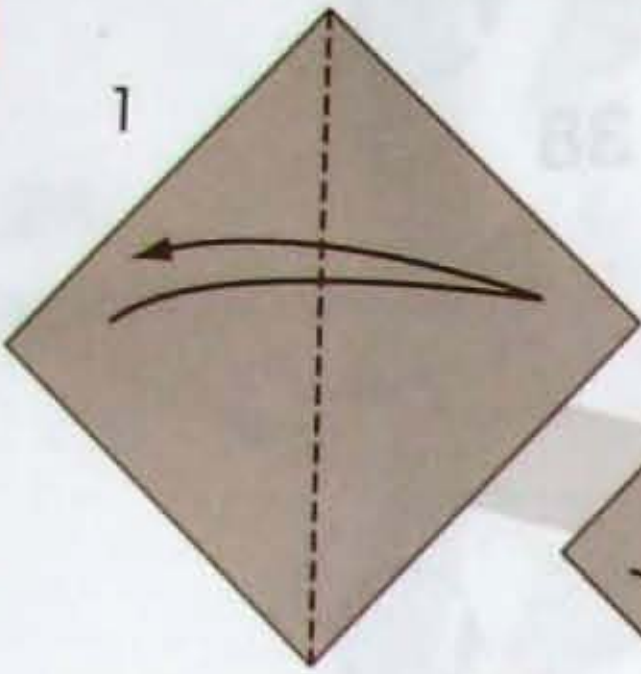
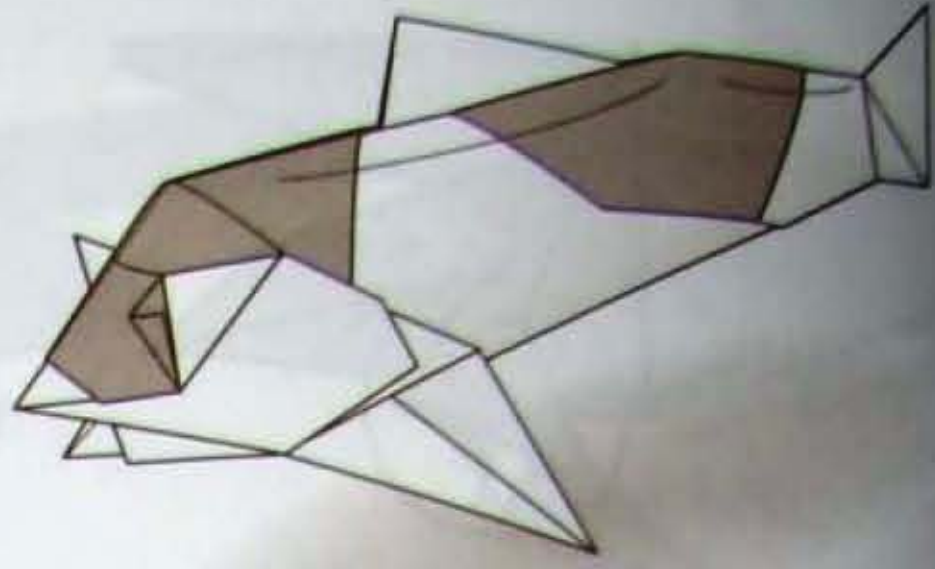

1 対角線で折り筋をつける

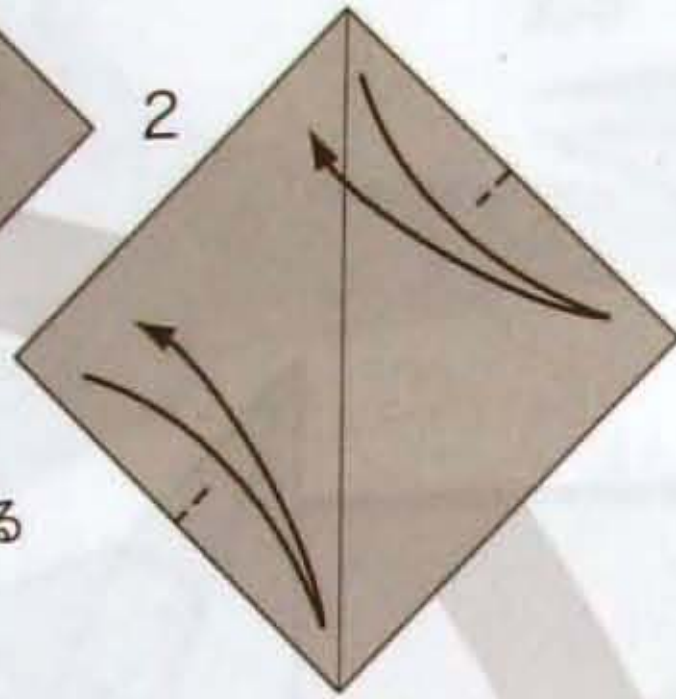

2 フチを合わせて折り筋をつける (フチに印をつけるだけでよい)

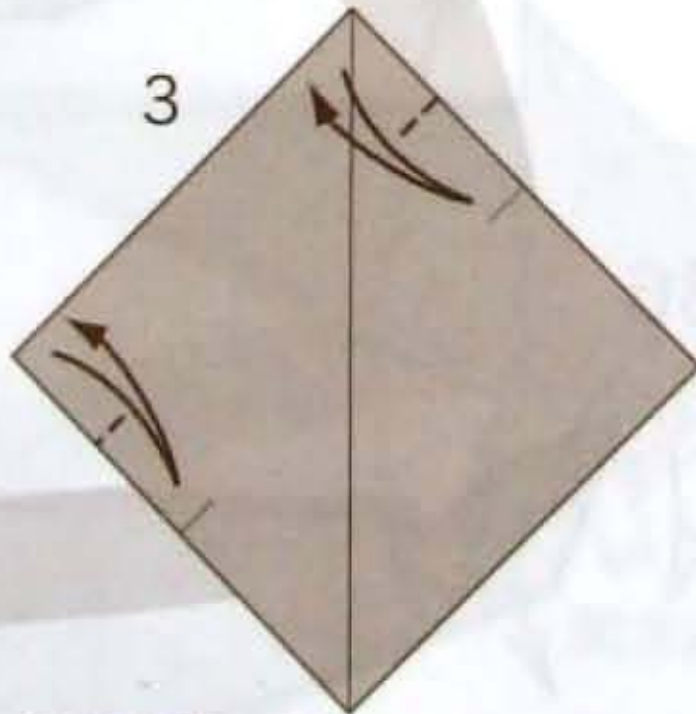

3 フチを印に合わせて折り筋をつける (印をつけるだけでよい)

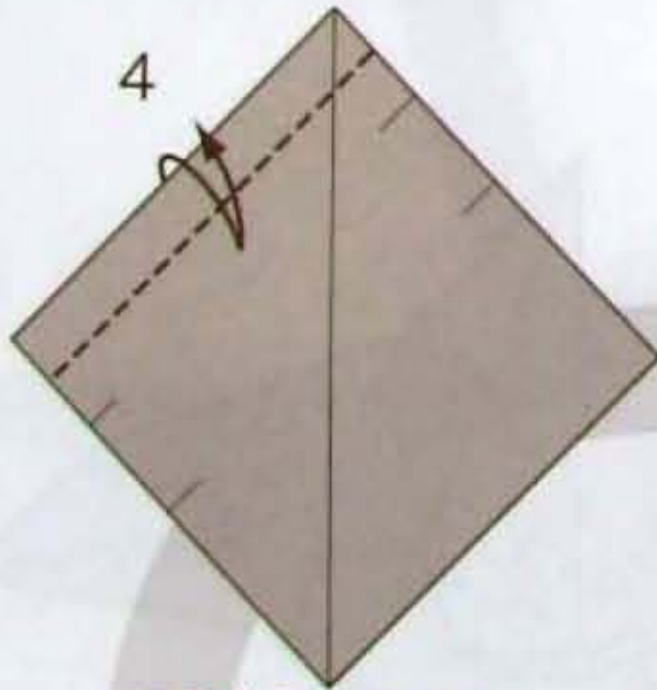

4 フチを印に合わせて折り筋をつける

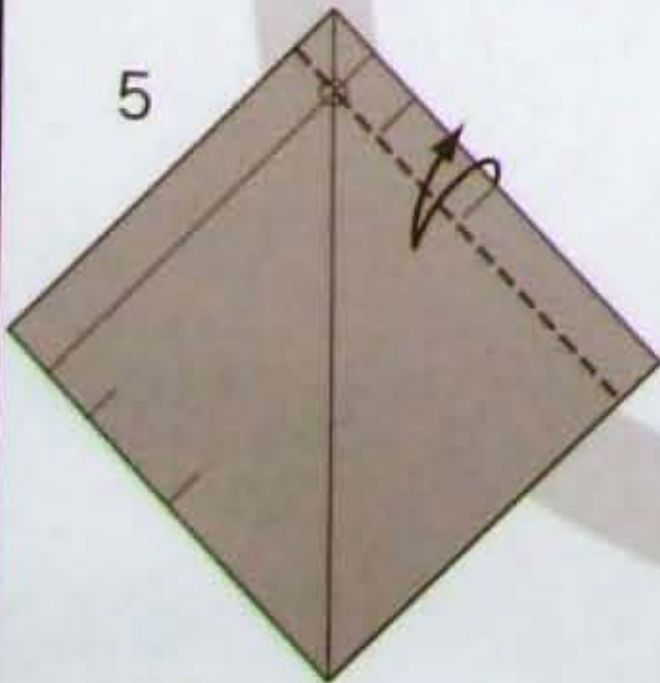

5 Oの交点を通る線で折り筋をつける

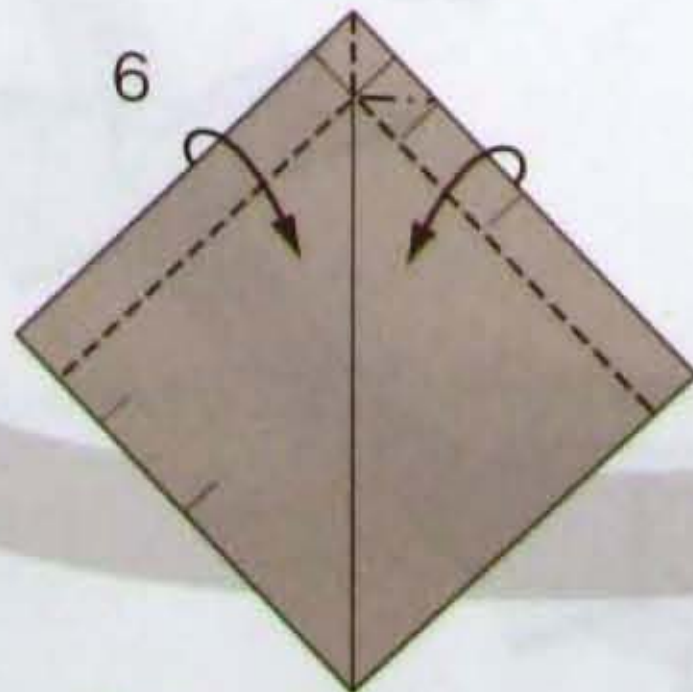

6 ついている折り筋でフチを折り返し、先端はつまみ折り

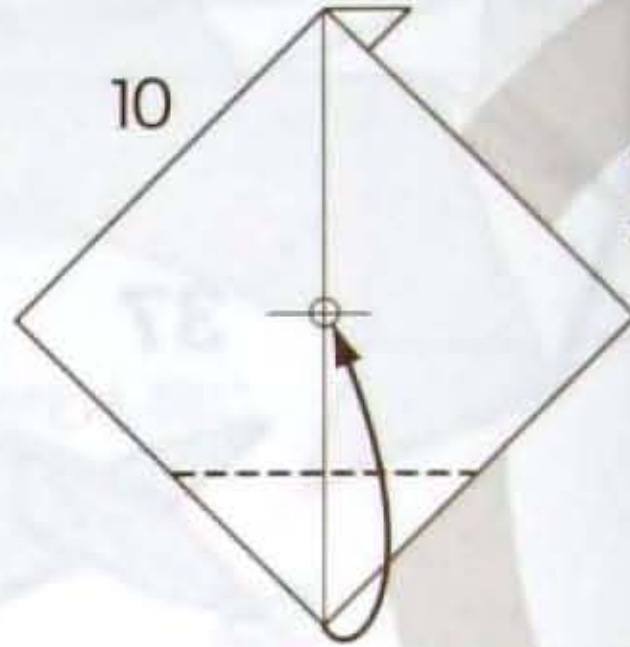

10 カドをOの交点に合わせて折り上げる

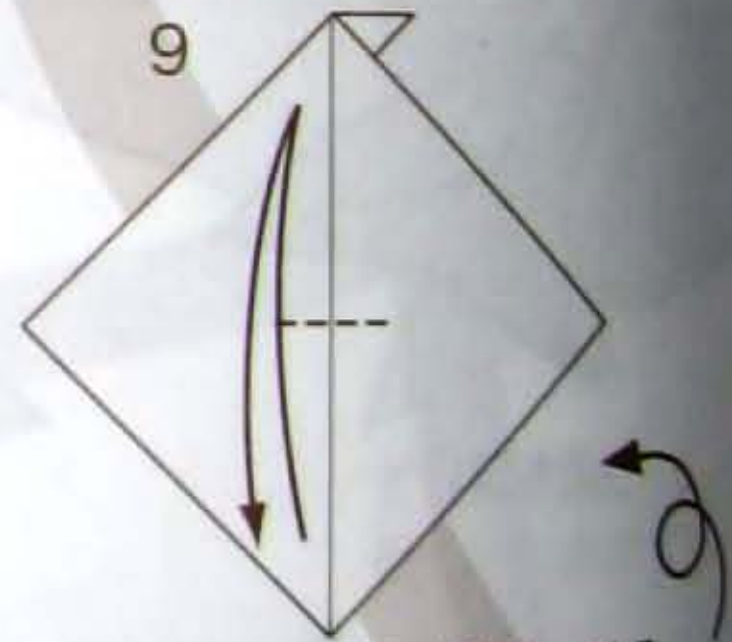

9 カドを合わせて折り筋をつける (印をつけるだけでよい)

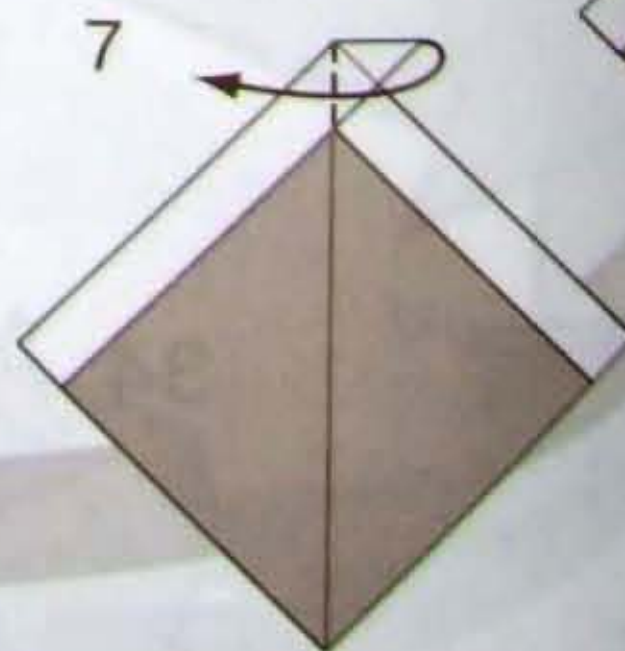
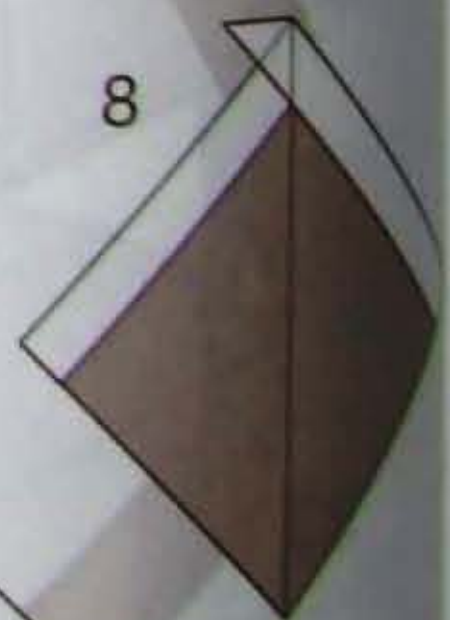

7 カドを反対側へたおす

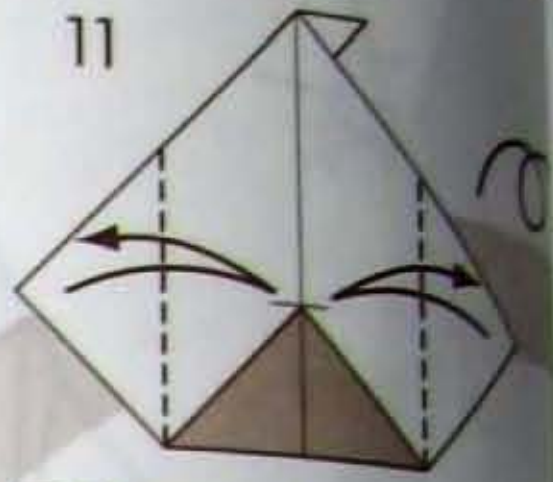

11 両端のカドを中心に合わせて折り筋をつける



12 Oを合



13 フチをOの折り筋をつ (折り筋は

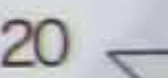

20 フチ折り

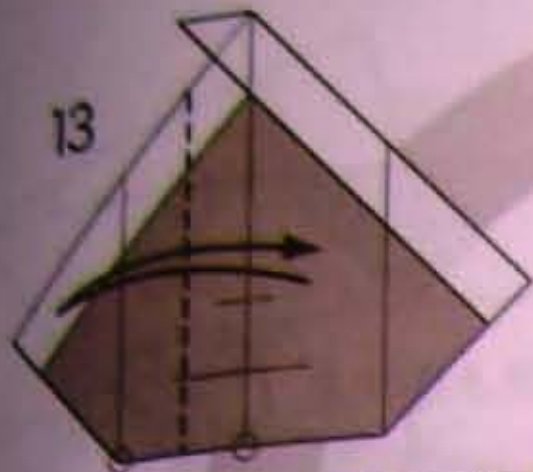

13
Oを合わせて折り筋をつける

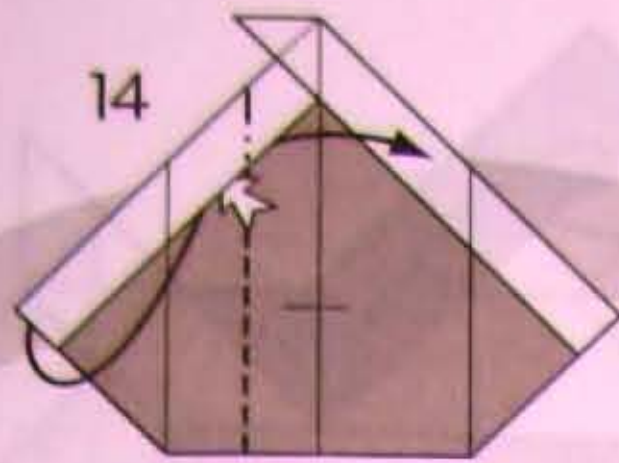

14
ついている折り筋で
中わり折り

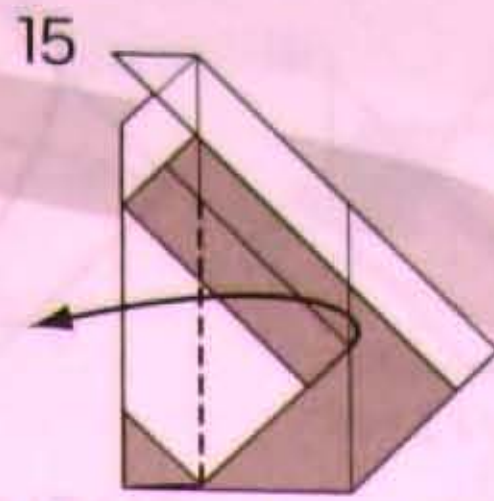

15
ついている折り筋で
カドを折り返す

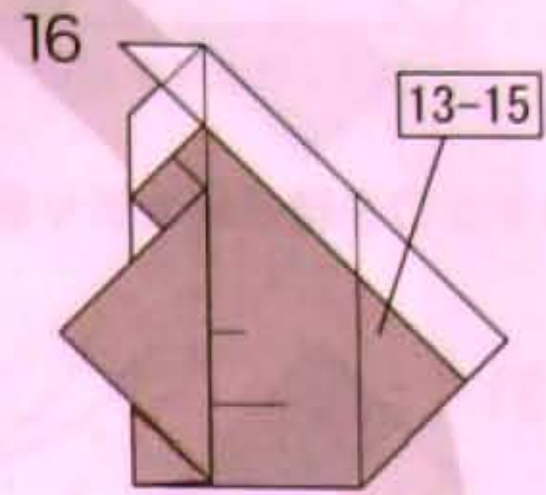

16
右側も同様に折る
(13-15)

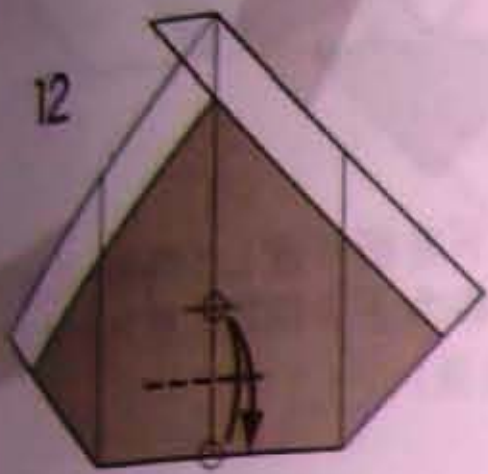

12
フチをOの交点に合わせて
折り筋をつける
(折り筋は図の長さ程度でよい)

Japão Burajirujin

www.japaoburajirujin.blogspot.com

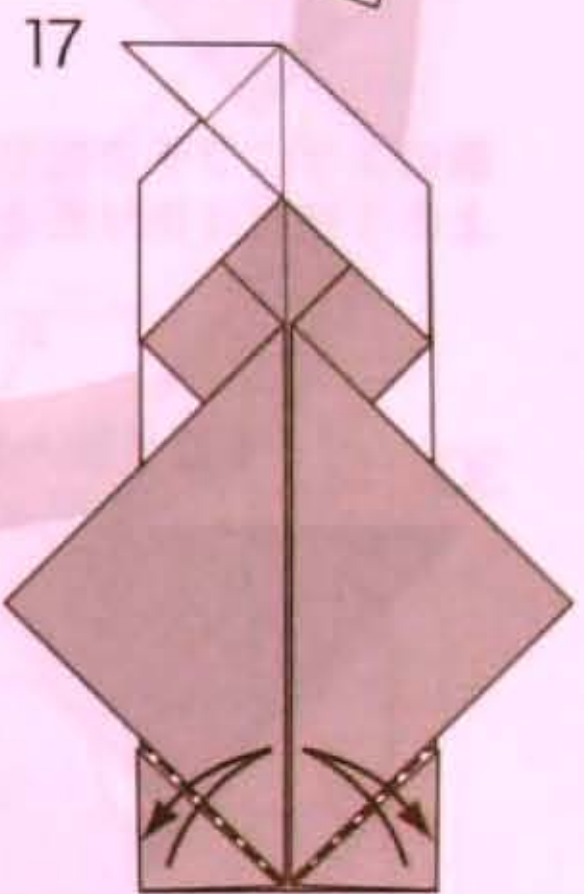

17
カドを中心線に合わせて
折り筋をつける

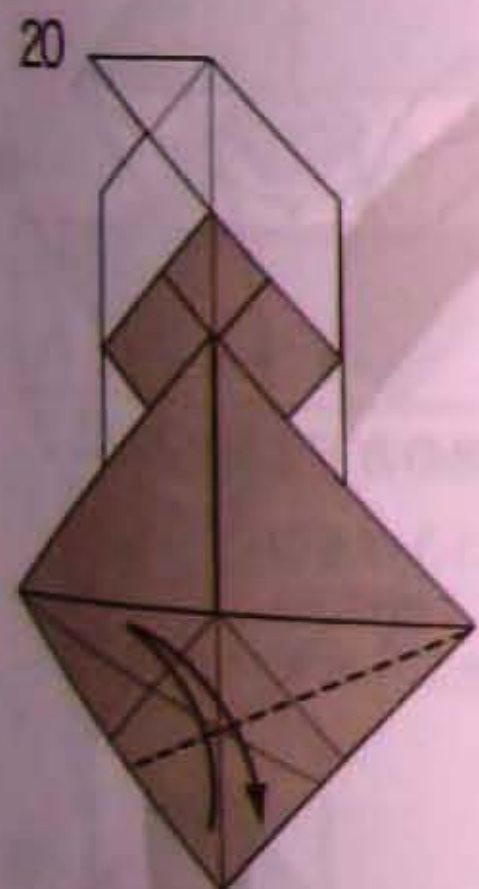

20
フチを合わせて
折り筋をつける

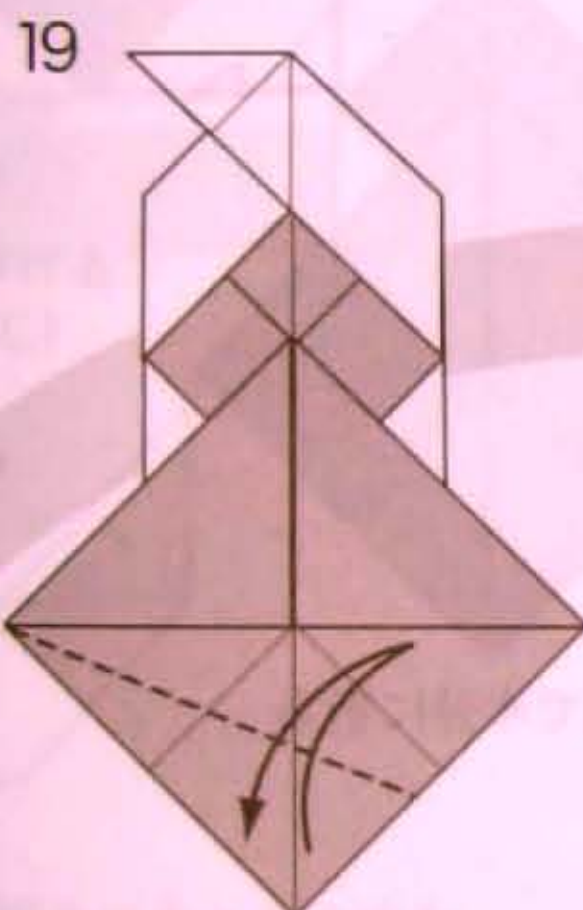

19
フチを合わせて
折り筋をつける

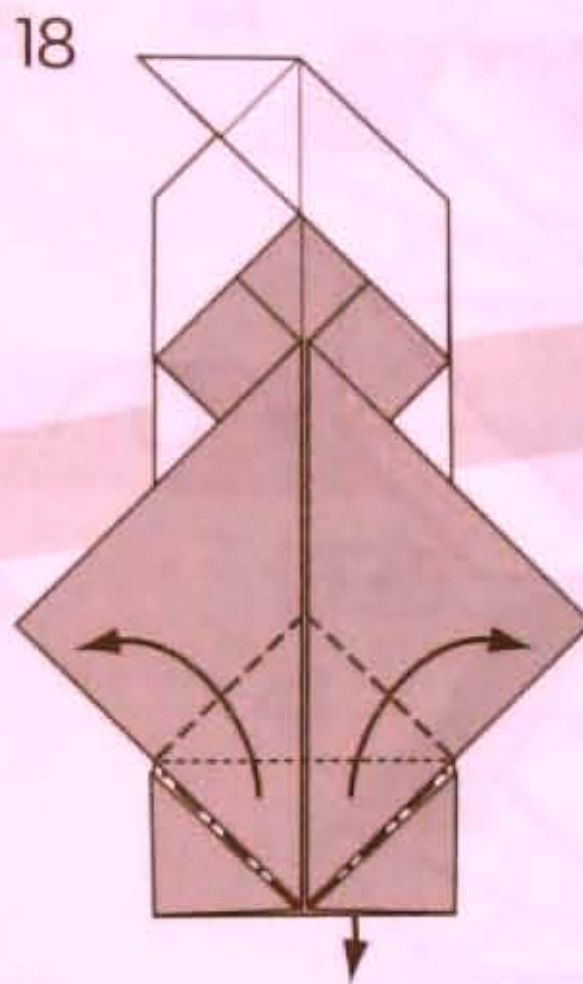

18
外側を開くようにカドを折り上げる
(後ろに折られているカドは下に出す)

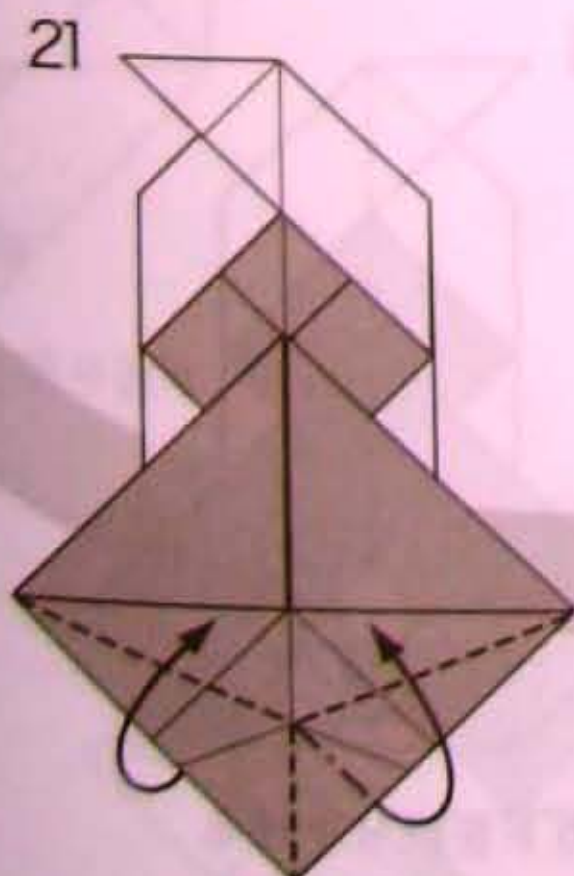

21
つまみ折り

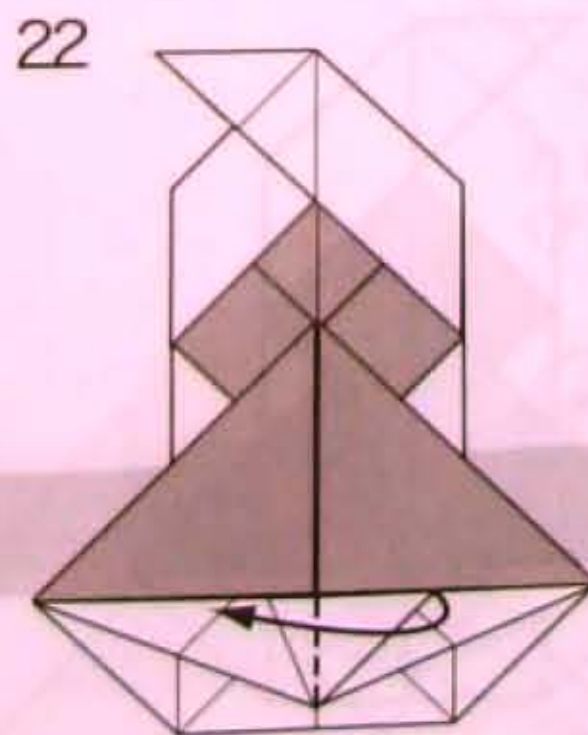

22
カドを反対側へたおす

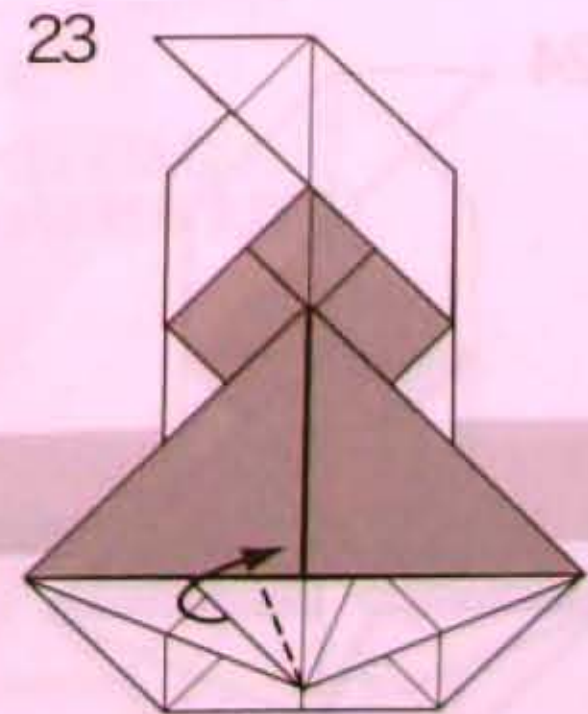

23
カドを中心線に合わせて折る

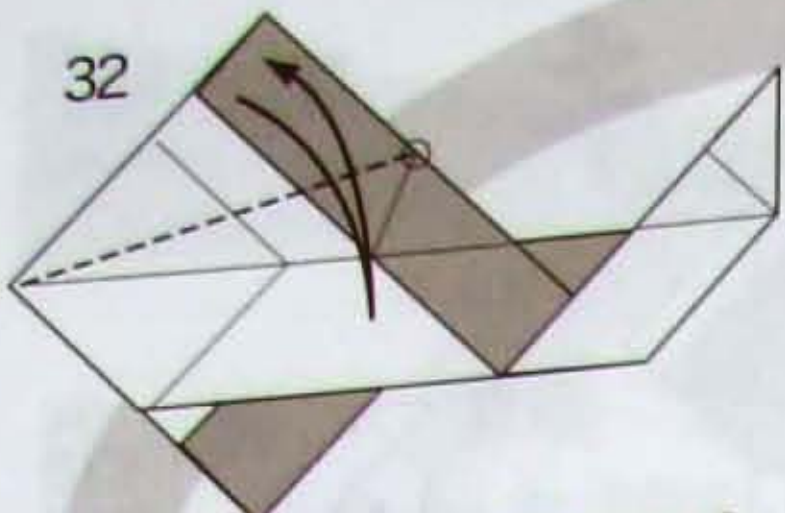

32
カドとOを結ぶ線で折り筋をつける

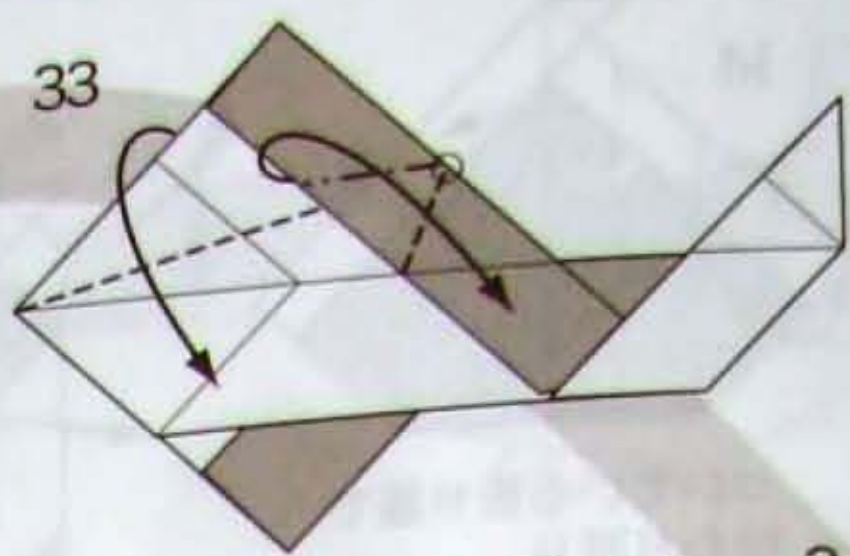

33
ついている折り筋で広げながらカドを折り下げる

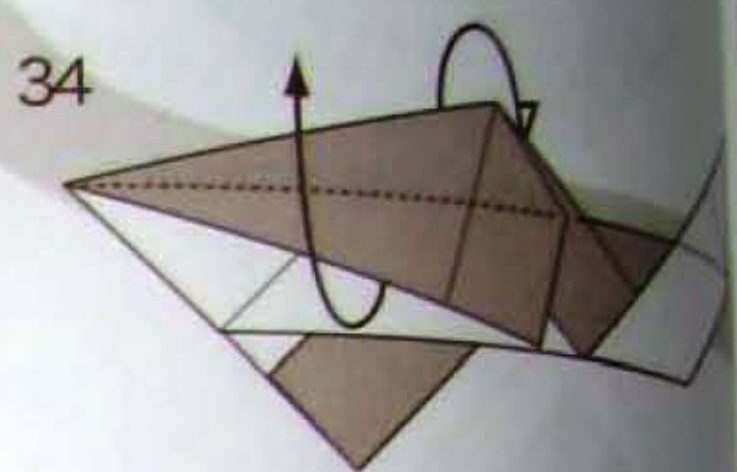

34
上のカドを折り返して内側へし、下向きのカドを同時に折り上げる

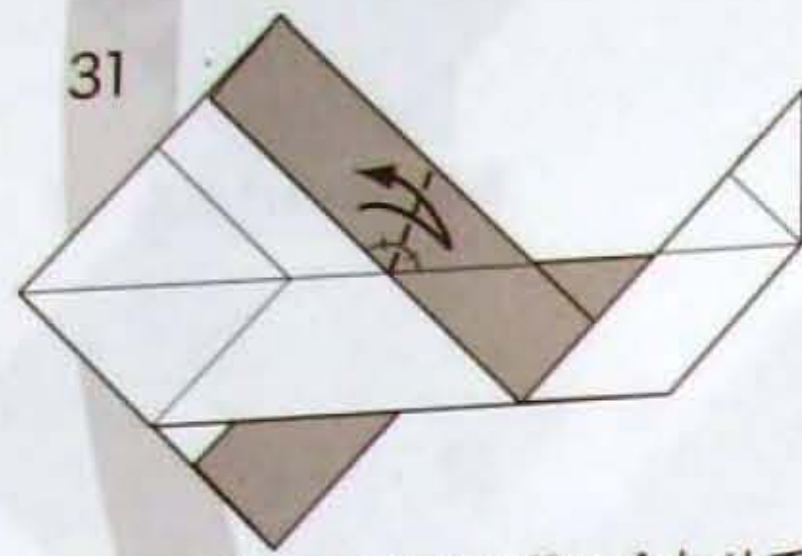

31
図のようにフチを折り筋に合わせて上の1枚だけ折り筋をつける

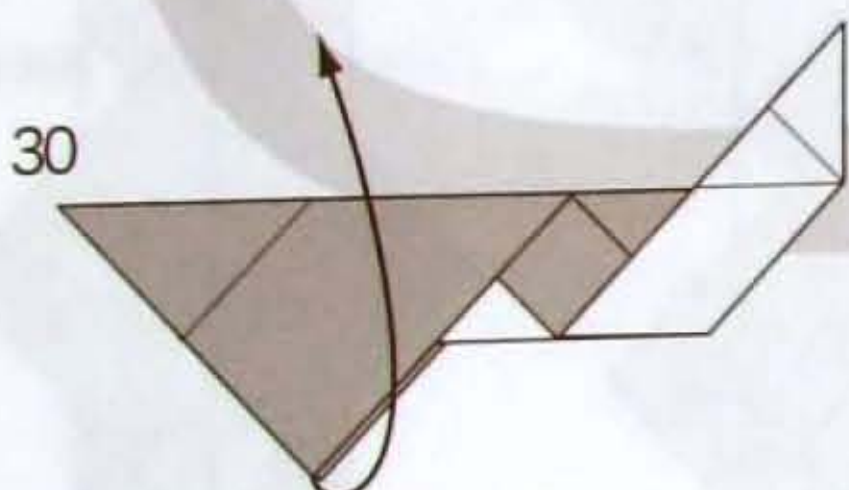

30
上に開く

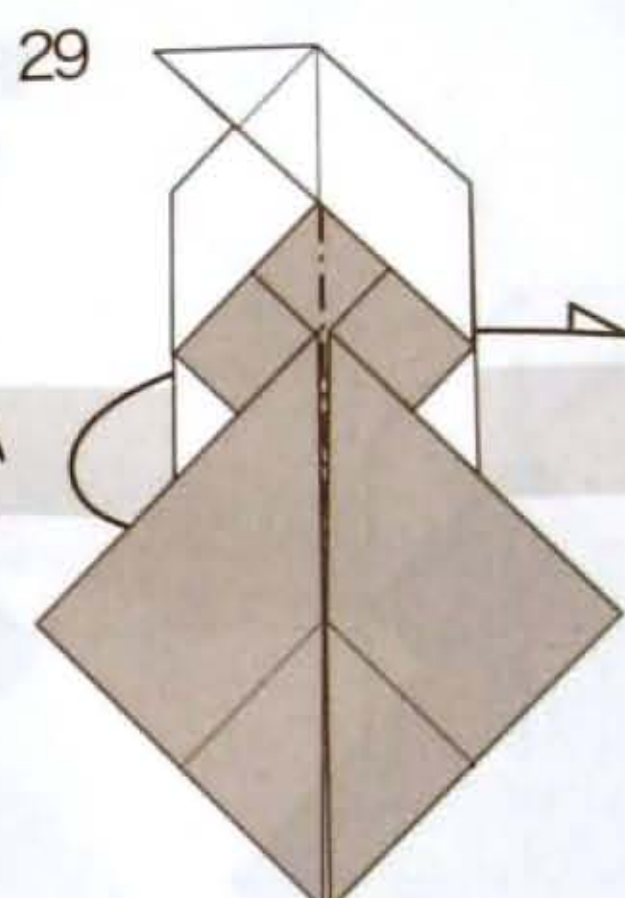

29
中心線で半分に折る

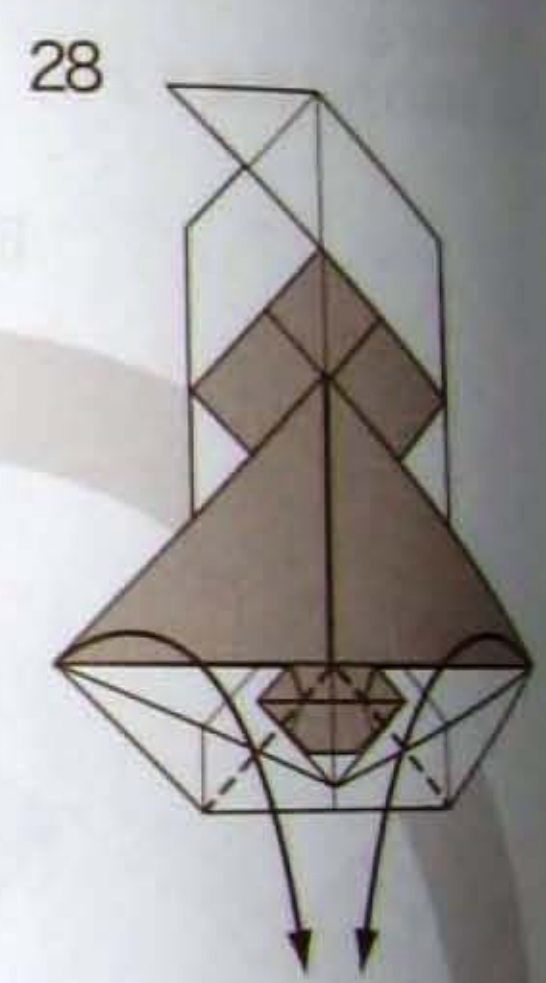

28
両側のカドを折り下げる

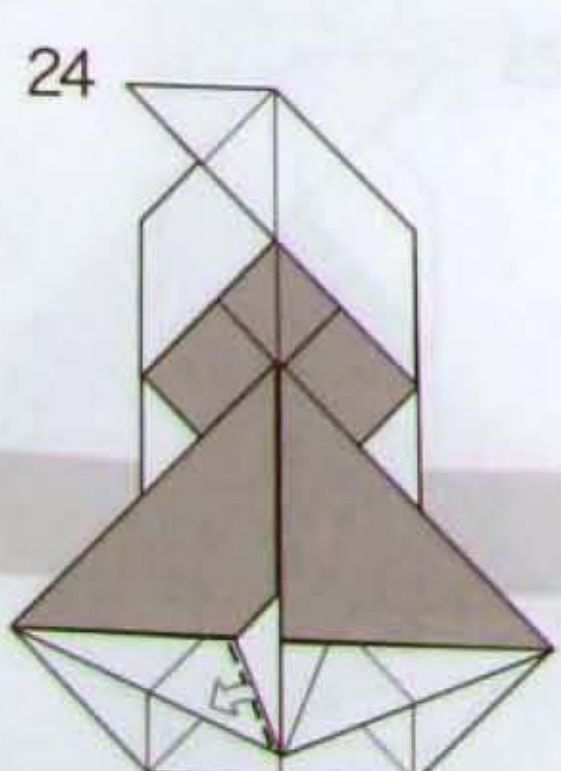

24
内側の紙を引き出す (次図参照)

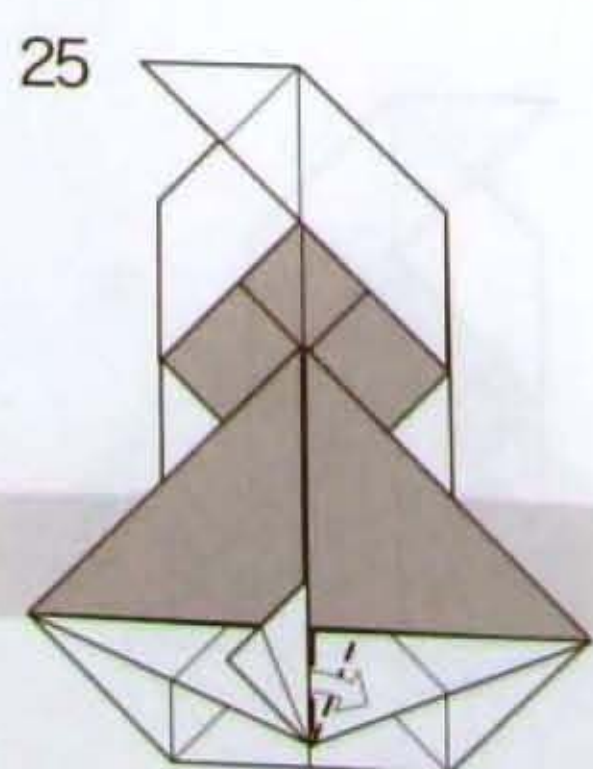

25
同様に内側の紙を引き出す

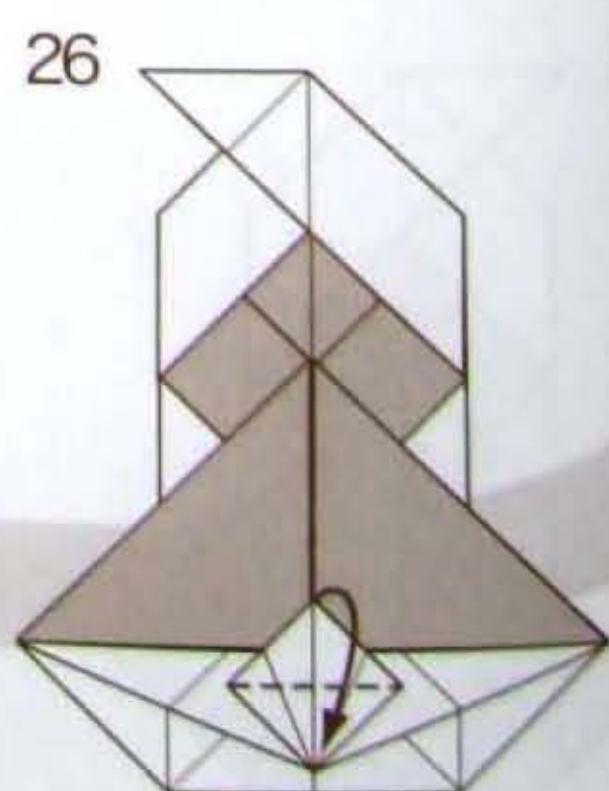

26
カドを折り下げる

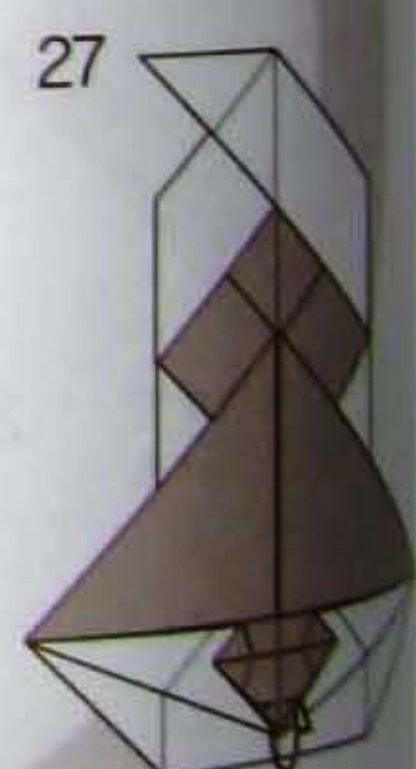

27
先端を裏に折り返す



35
30-34

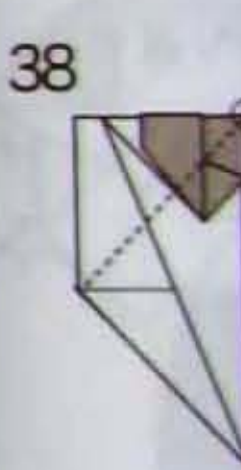

38



39



反対側も同様に折る
(30-34)

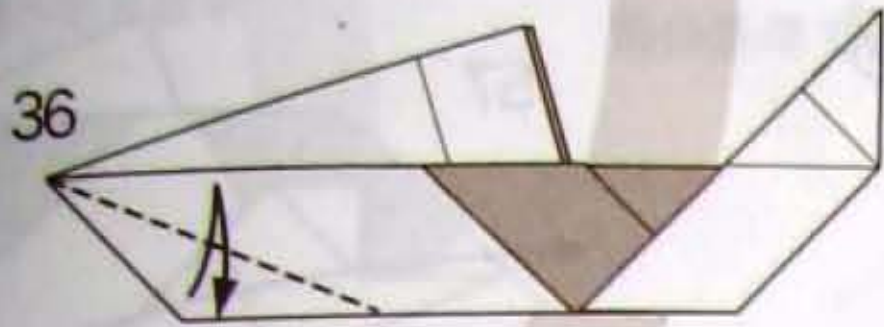

フチを合わせて折り筋をつける
(反対側も同じ)

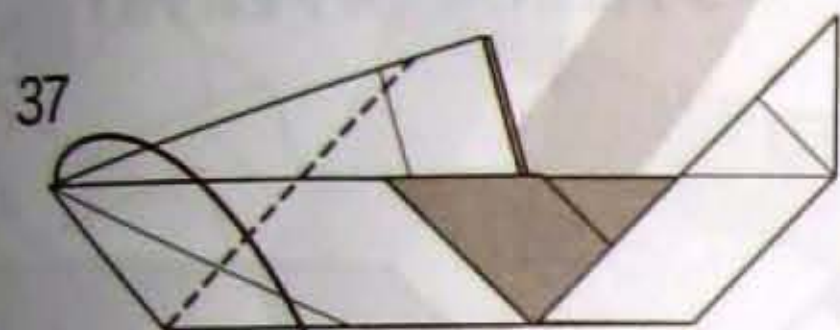

カドを折り下げる
(反対側も同じ)

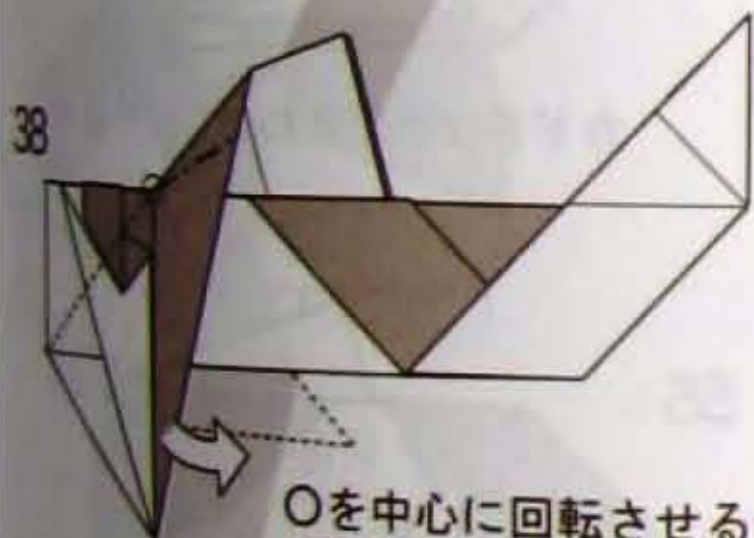

Oを中心に回転させるように折る
(反対側も同時に折る)
※カドは水平になる

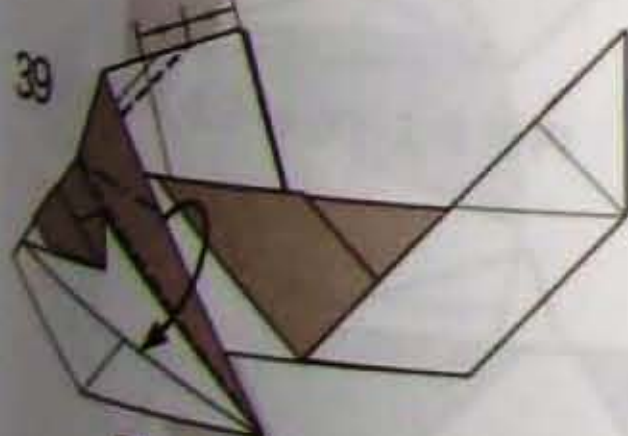

図の基準でフチを折り返す

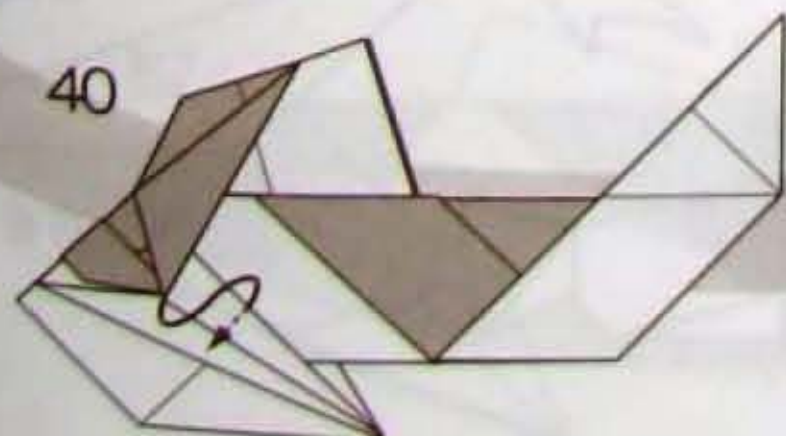

フチをすぐ下に入れる

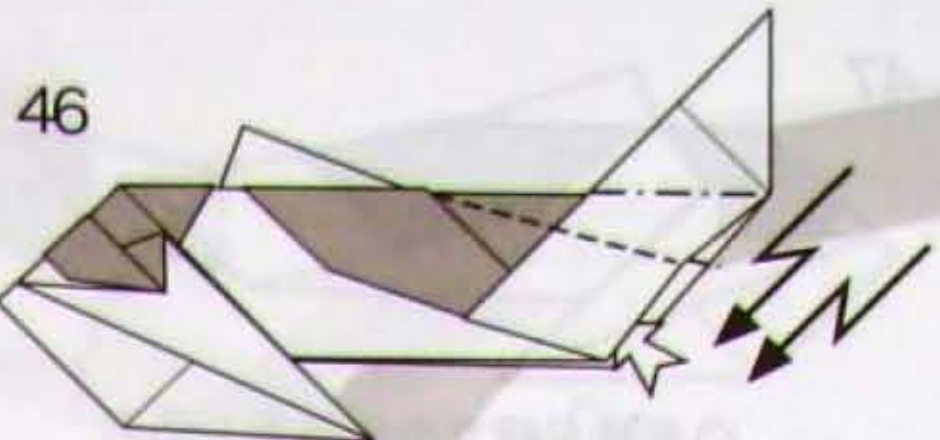

ついている折り筋で内側に段折り

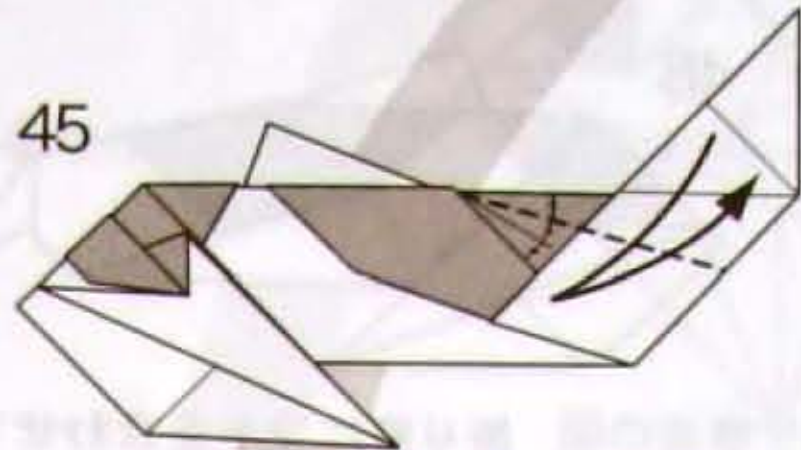

1/3の角度で折り筋をつける

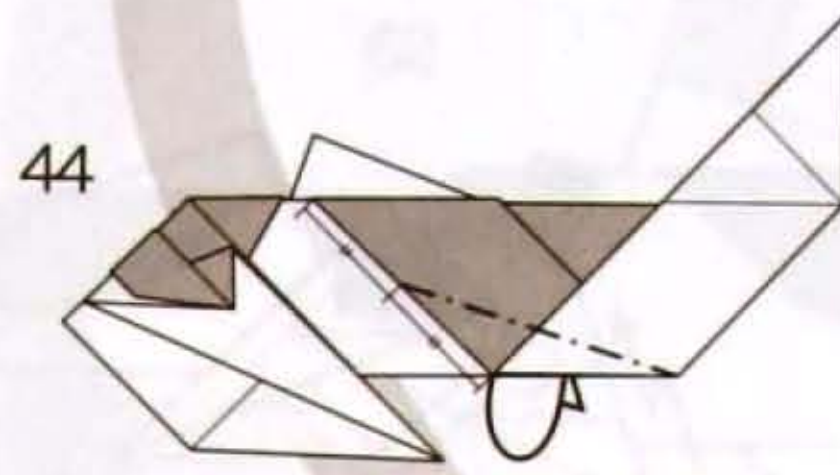

カドを裏へ折り返す
(反対側も同じ)

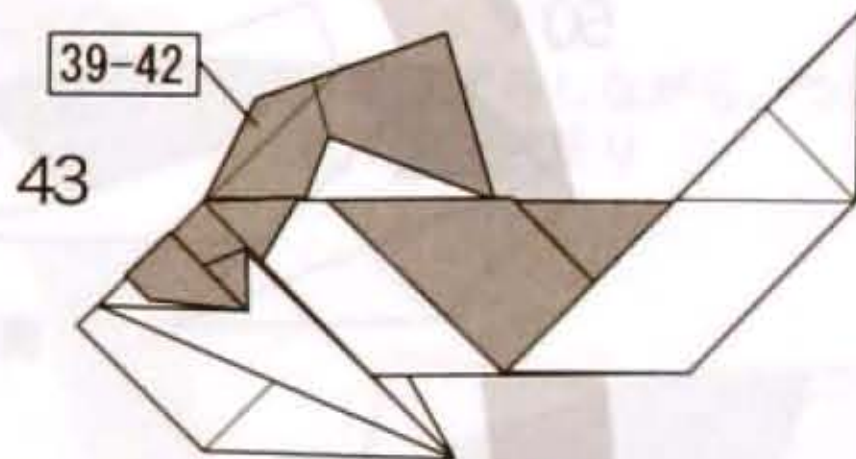

反対側も同様に折る
(39-42)

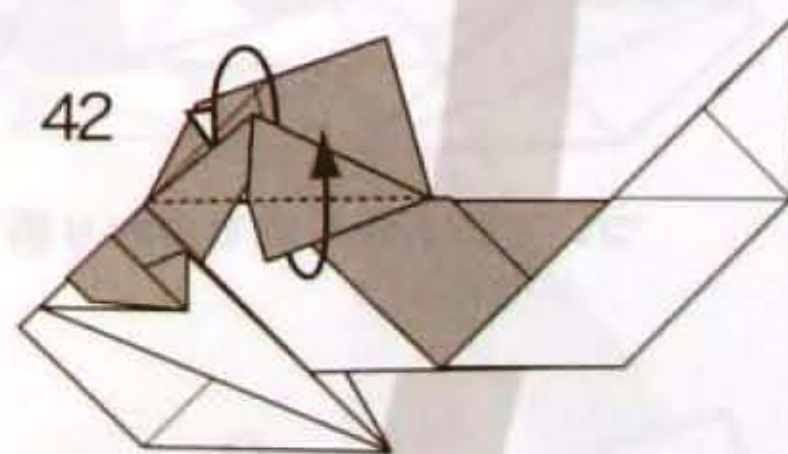

カドを内側へ折り込む
(下向きのカドは折り上げる)

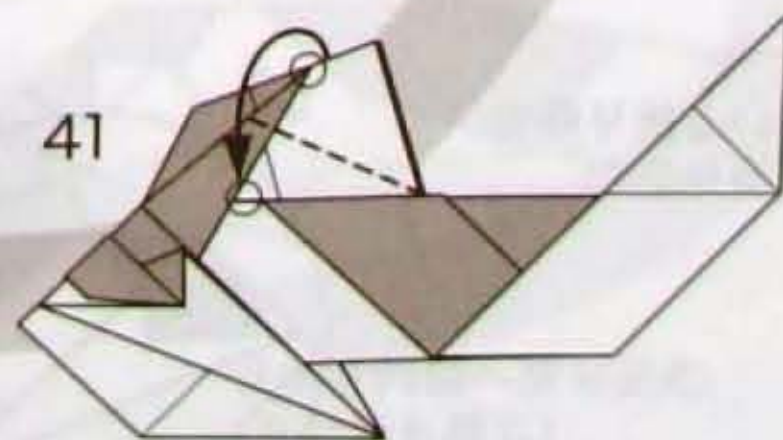

Oを合わせてカドを折る

まい、
る

47

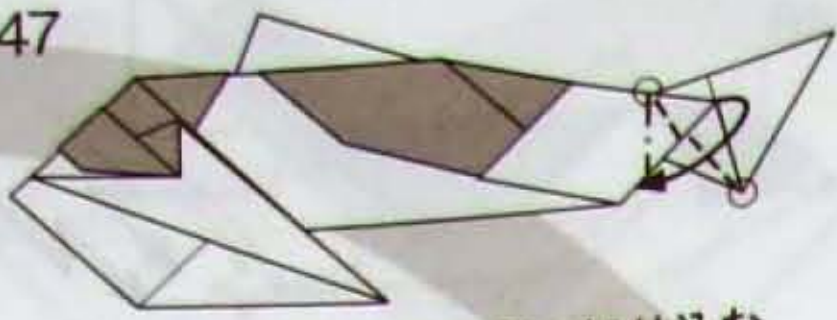

○を結ぶ線で内側へ折り込む

48

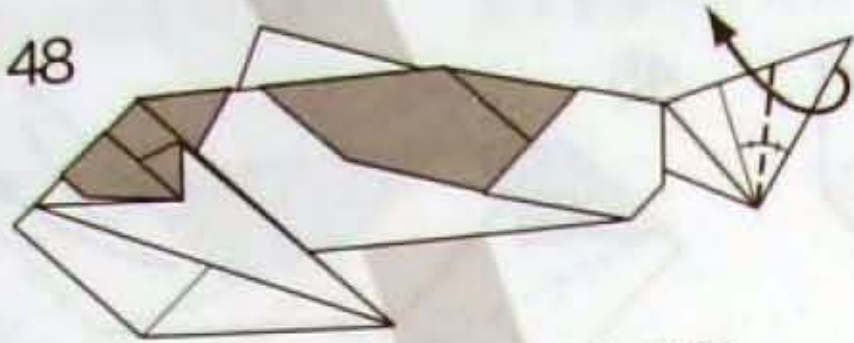

折り筋にフチを合わせて
折り筋をつける

49

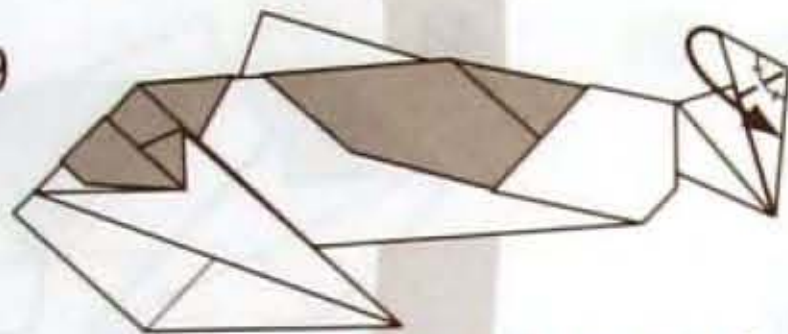

カドをフチを合わせて折る

50

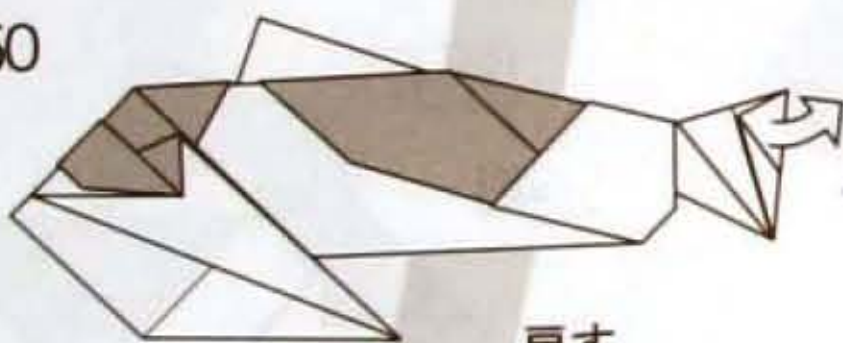

戻す

51

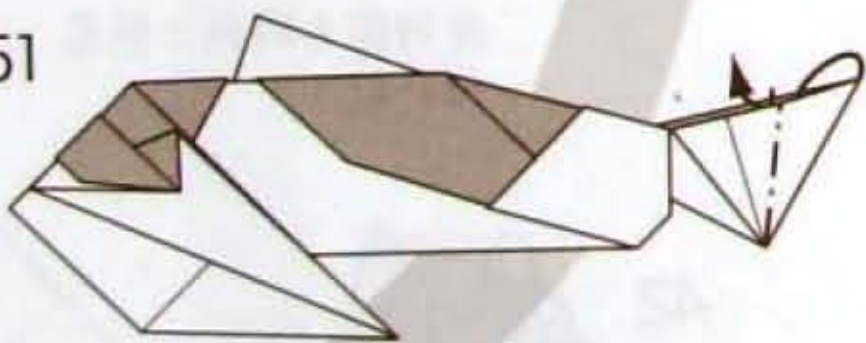

ついている折り筋で中わり折り

52

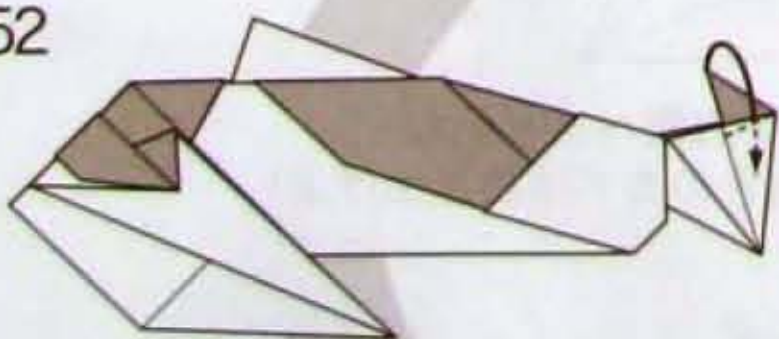

ついている折り筋で
内側へ折り込む

53

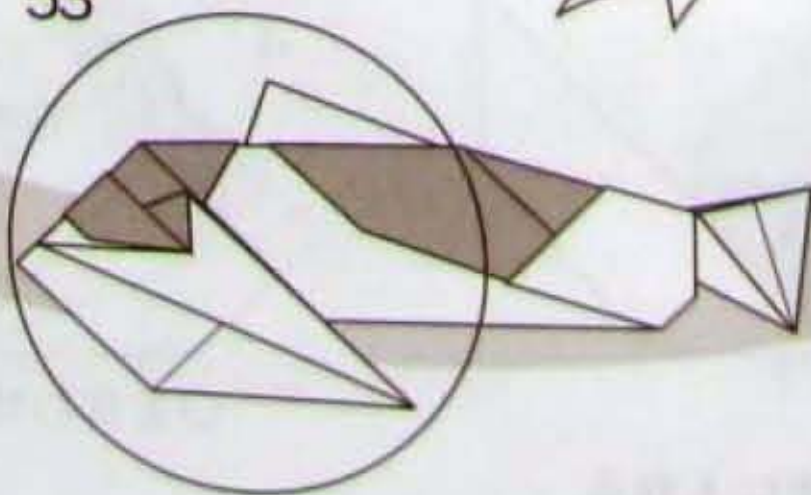

54

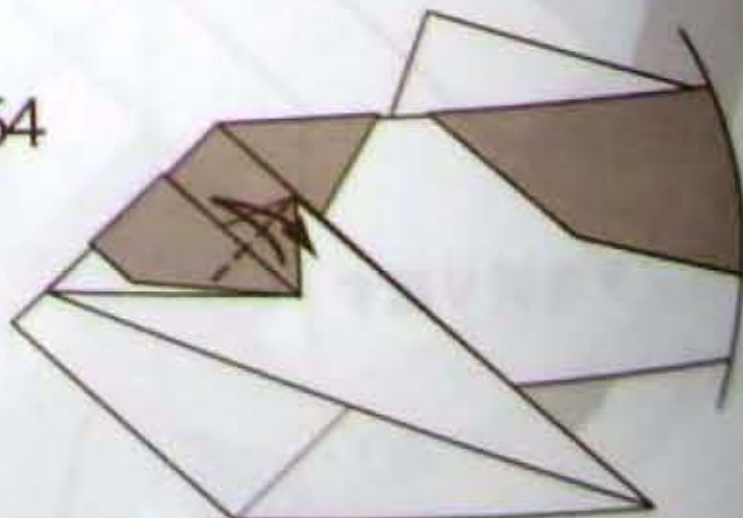

折り筋をつける

58

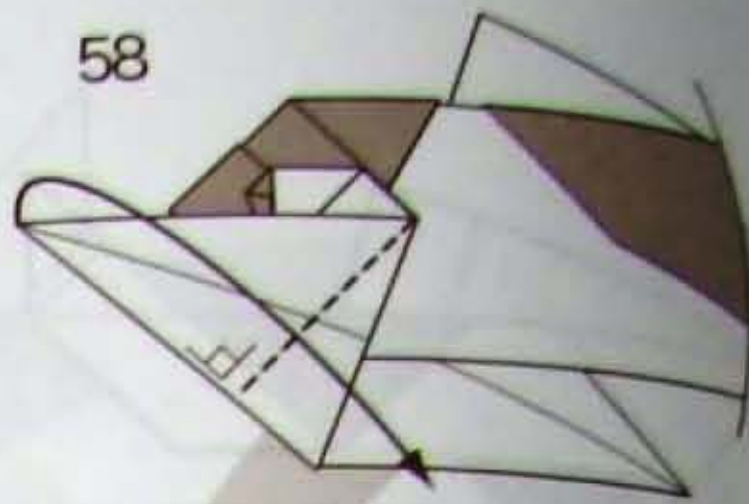

カドを直角に折り返す

57

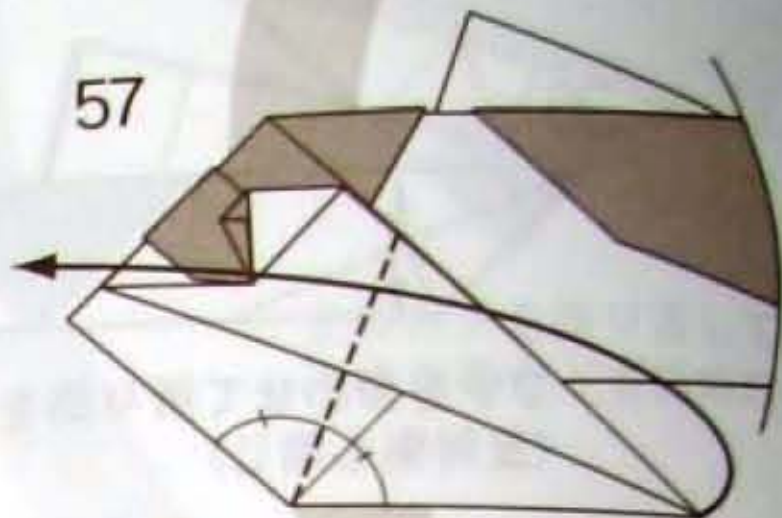

フチに合わせてカドを折り返す

56

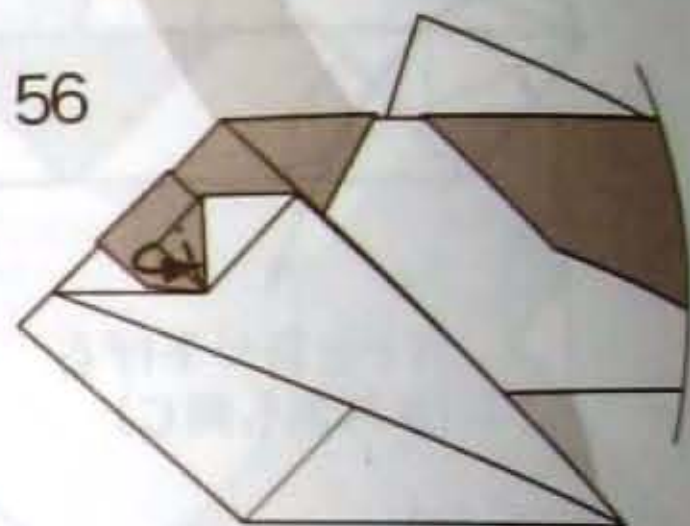

カドをフチに合わせて折り返す

55

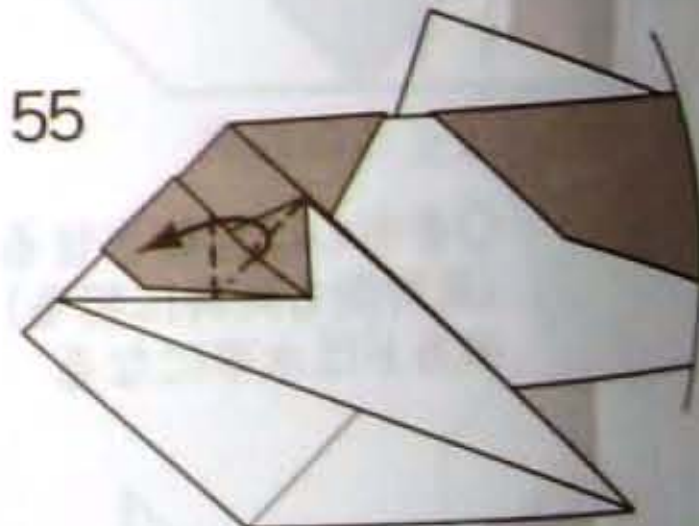

内側を広げながらカドを折る

59



フチを

64

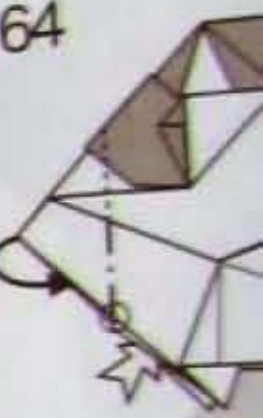

図の
中わ

65

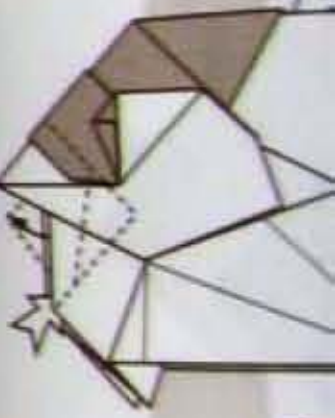

中

66

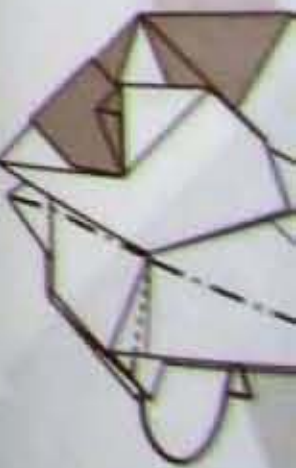

ずらしなが
(反対側も

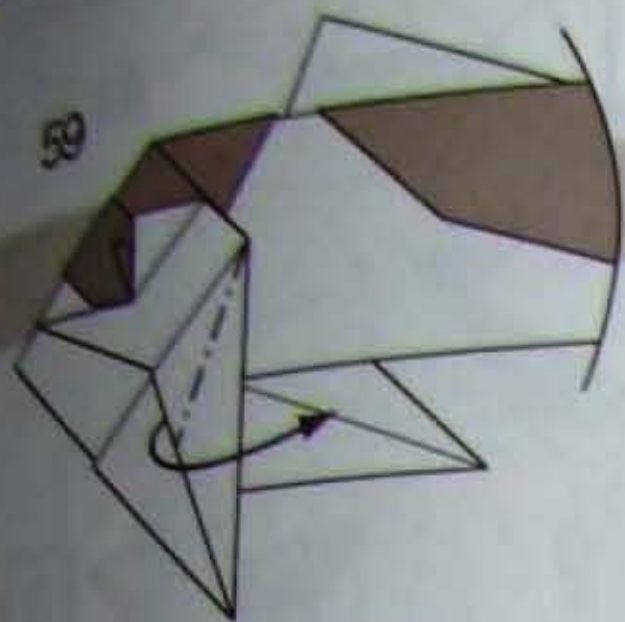

フチを外側へ引き出す

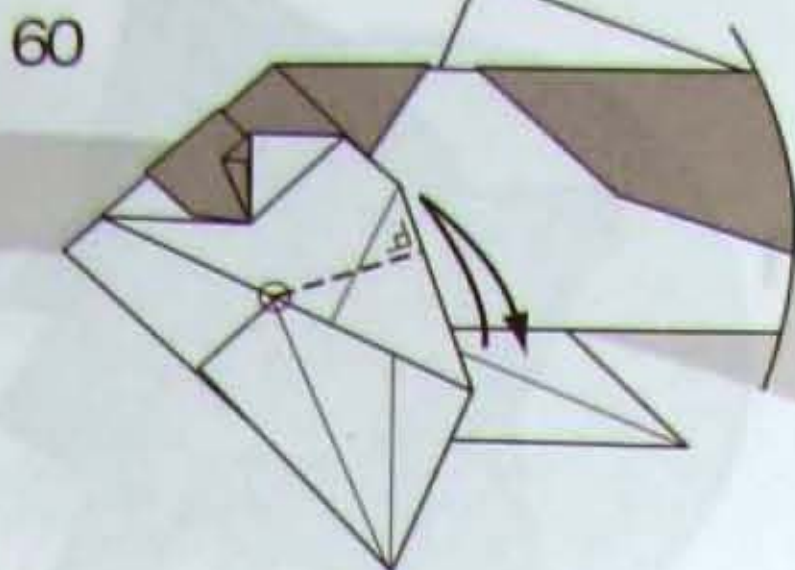

図の基準で折り筋をつける

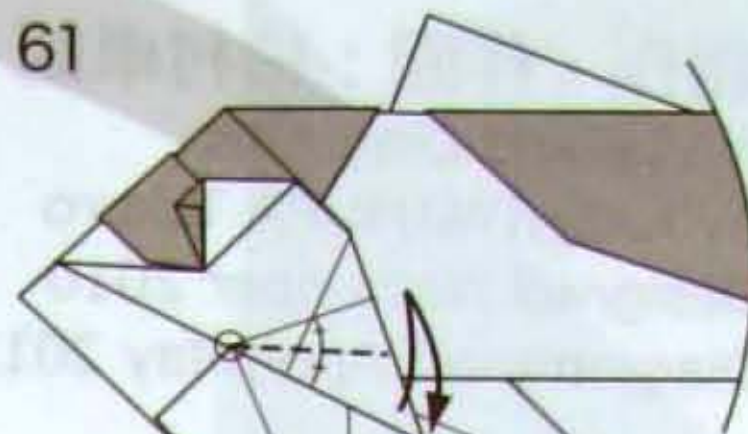

図の基準で折り筋をつける

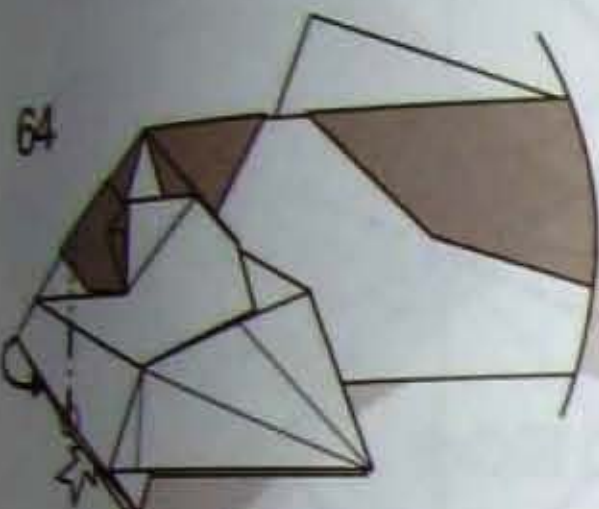

図のカド(内側)の位置で
中わり折り

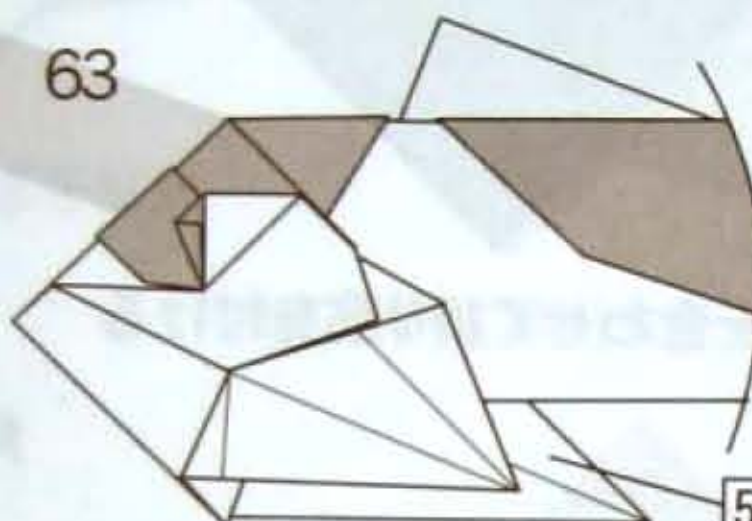

反対側も同様に折る
(54-62)

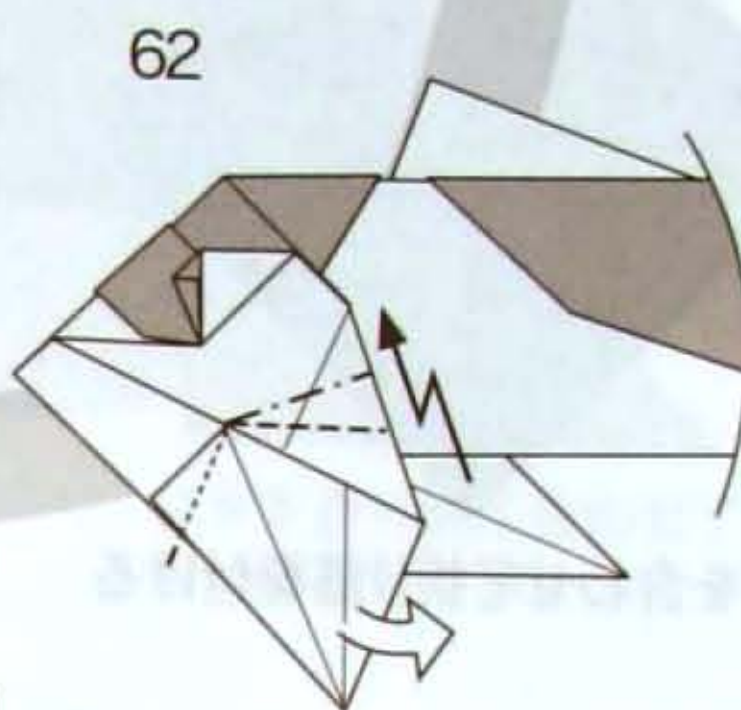

カドをずらしながら、ついている
折り筋で段折り

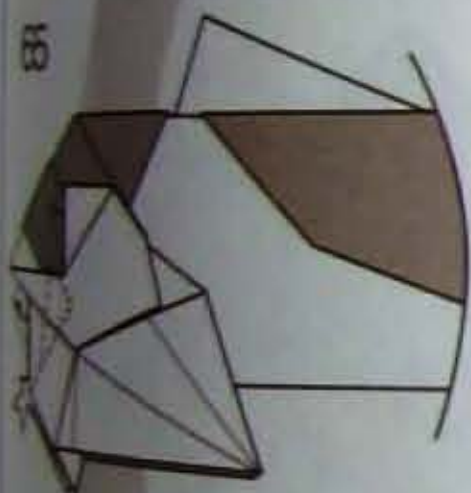

中わり折り

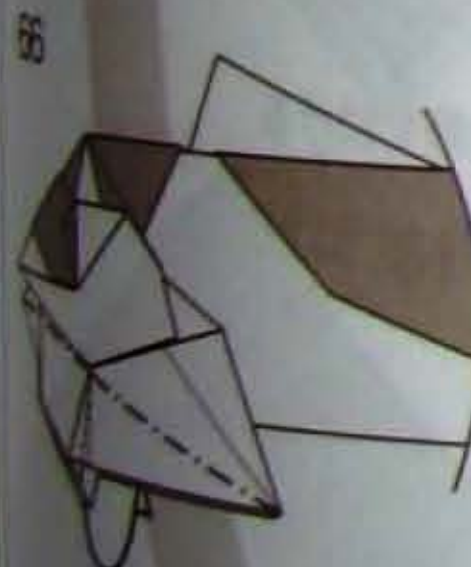

ずらしながら内側へ折り込む
(反対側も同じ)

- ◆仕上げのポイント
- ・背びれを糊付けする
 - ・胸びれを外側へ広げる
 - ・背中に丸みをつけると上から見たときキレイ

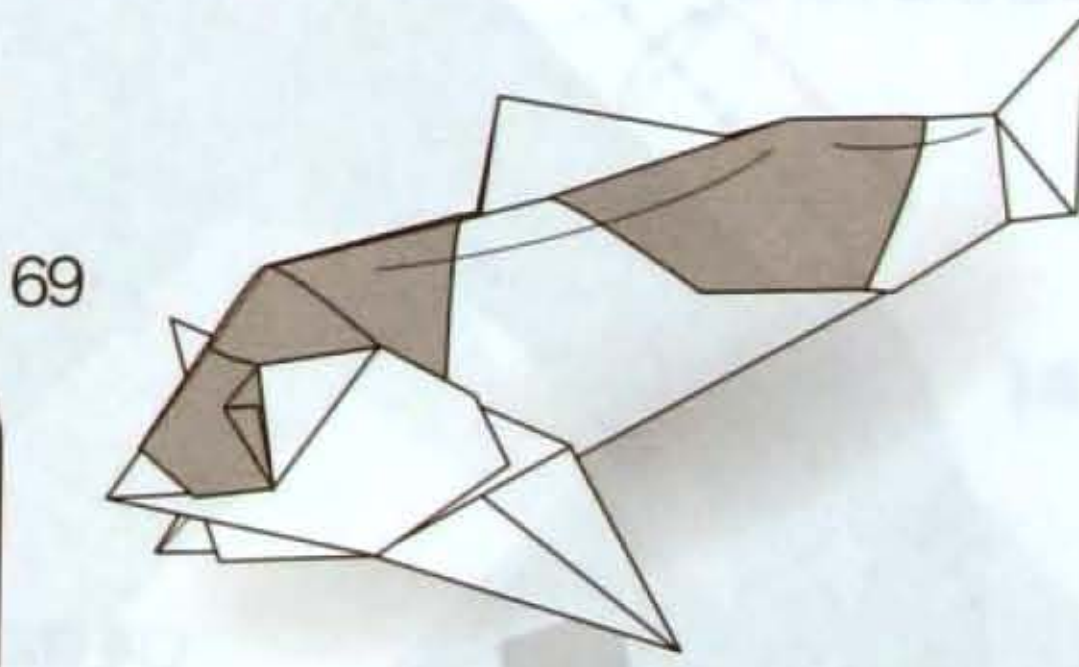

できあがり

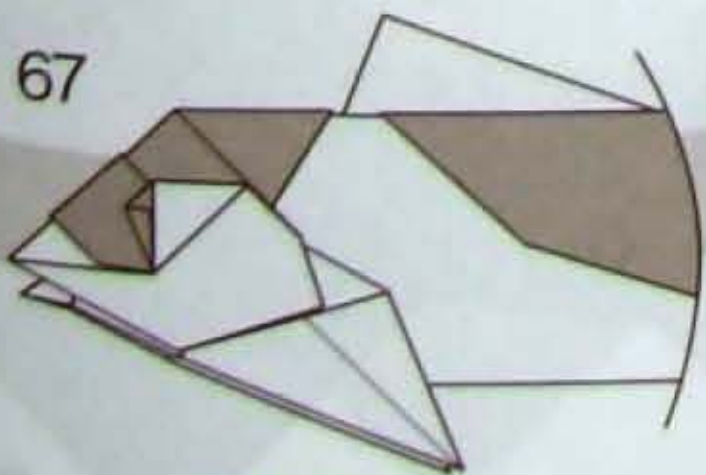

頭部完成

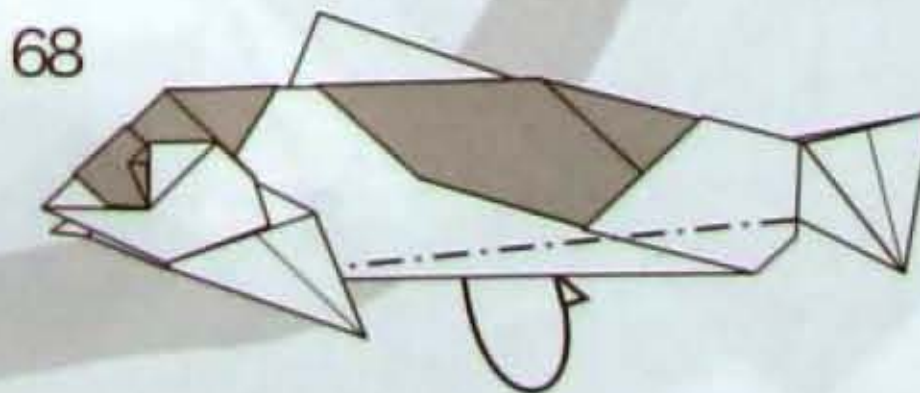

フチを内側へ折り込む
(反対側も同じ)

流金 Ryukin

創作・作図：柏村卓朗
Model and Diagrams
by KASHIWAMURA Takuro
Designed: November 2010
Diagrammed: April/May 2011

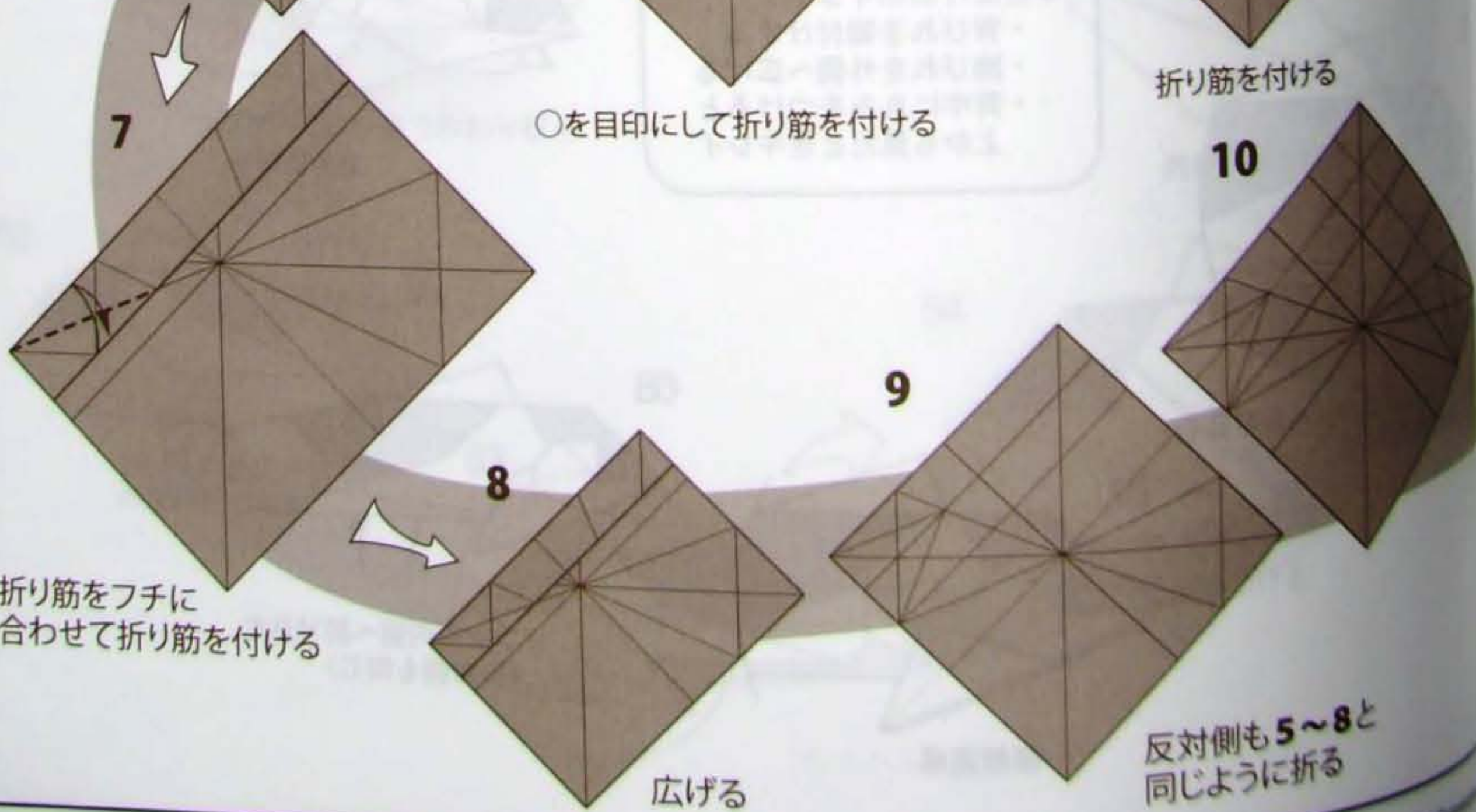
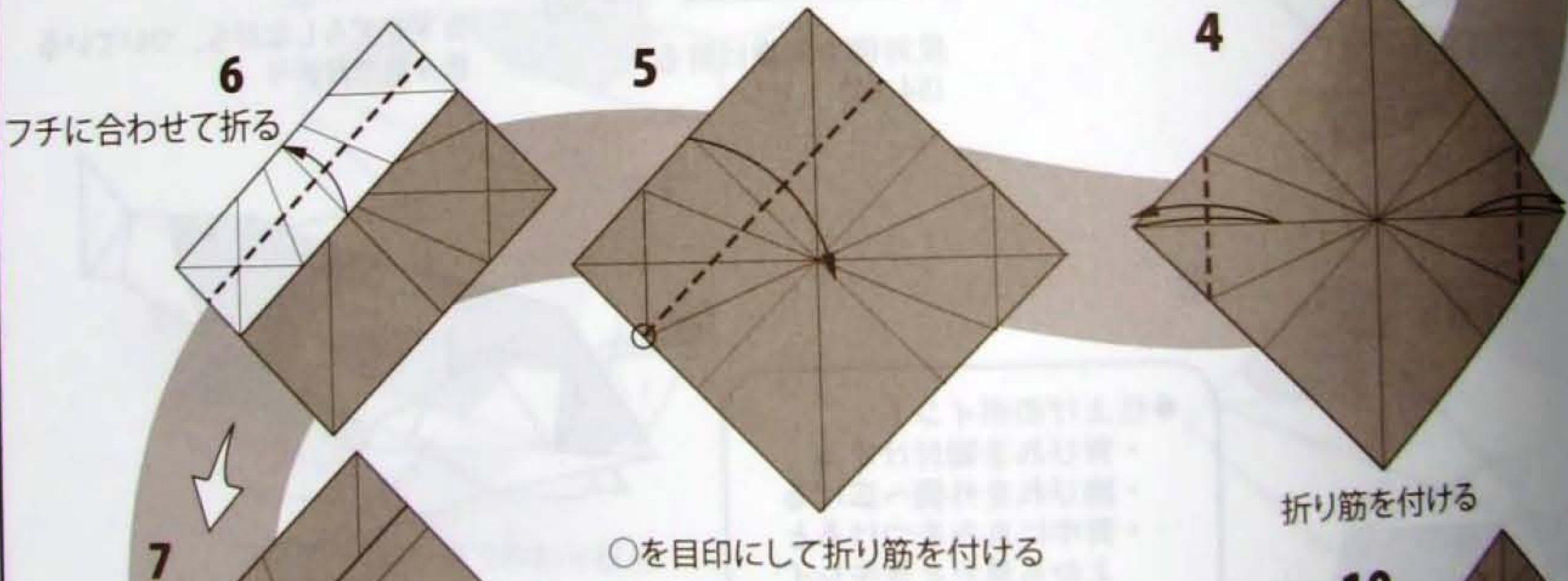
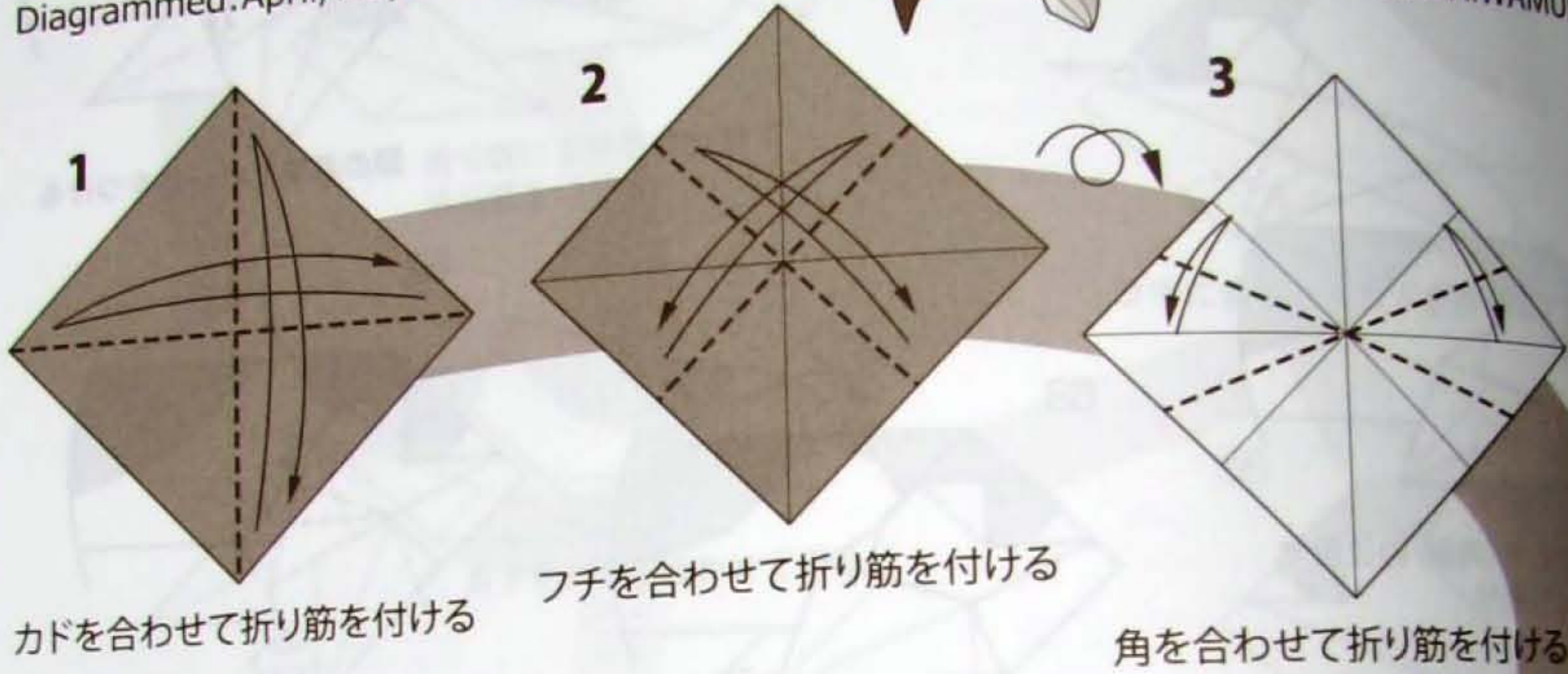
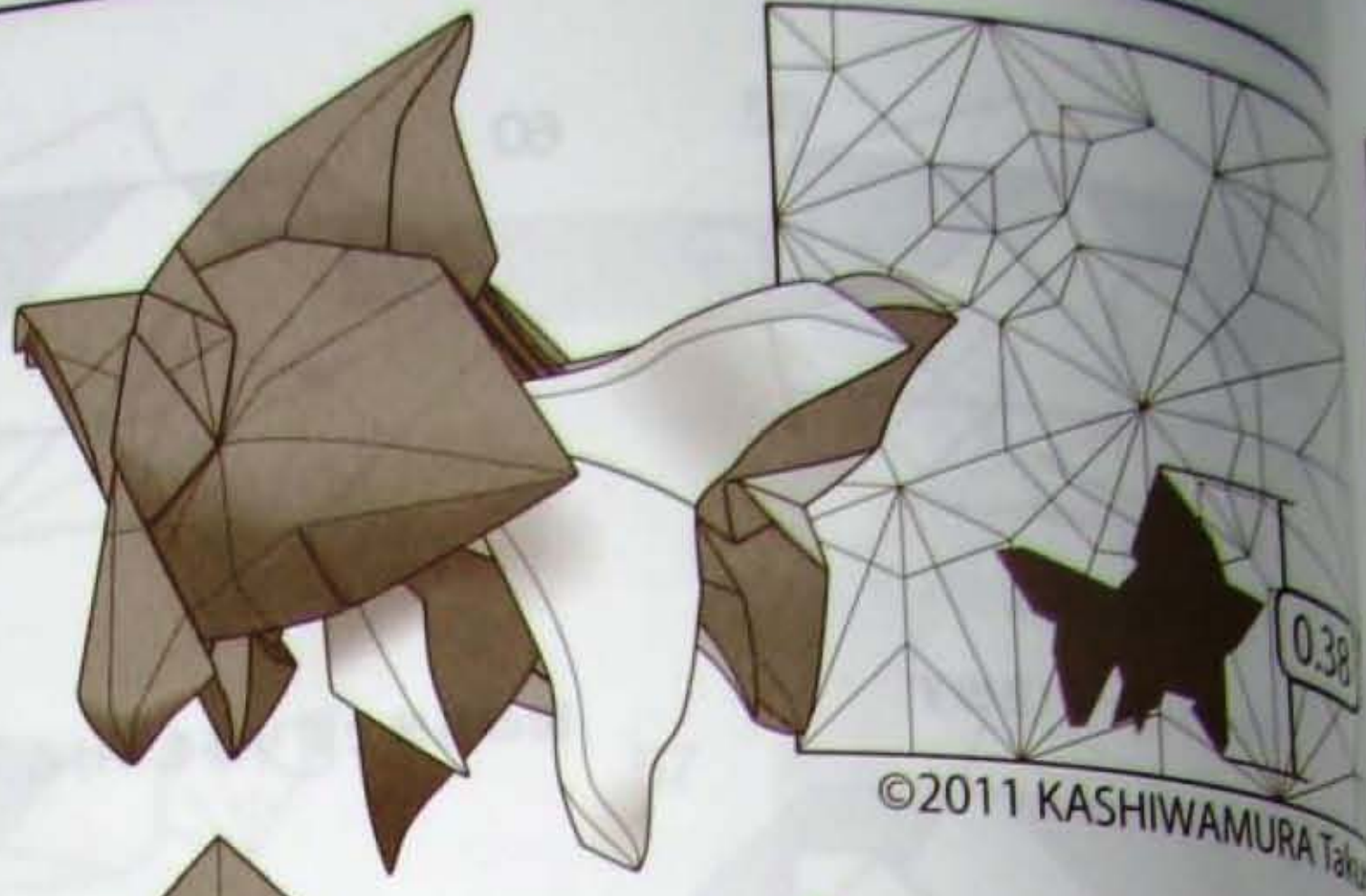

18

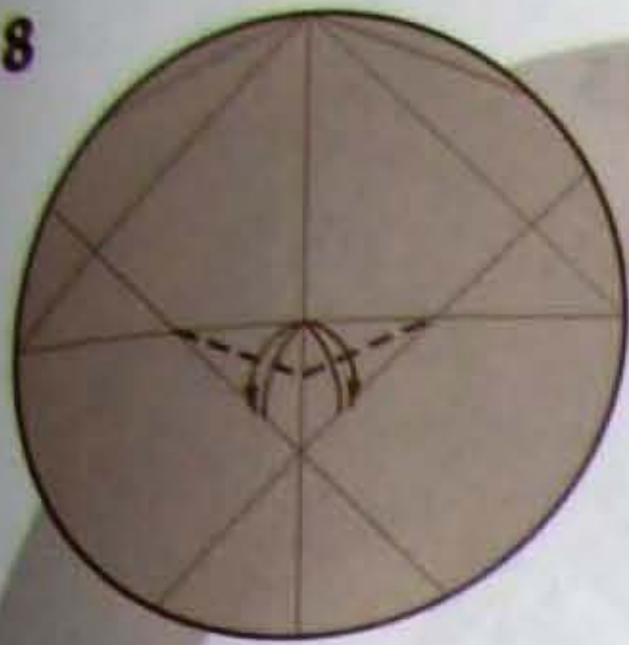

折り筋を半分にして折り筋を付ける

19

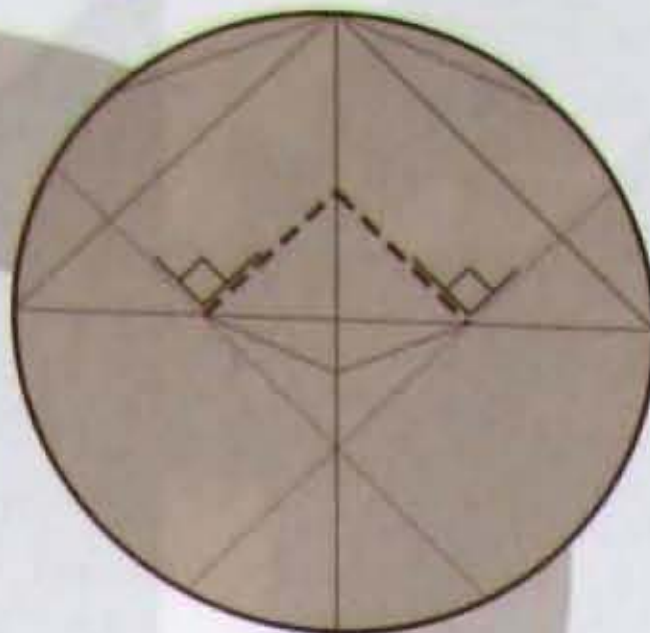

直角に折り筋を付ける

22

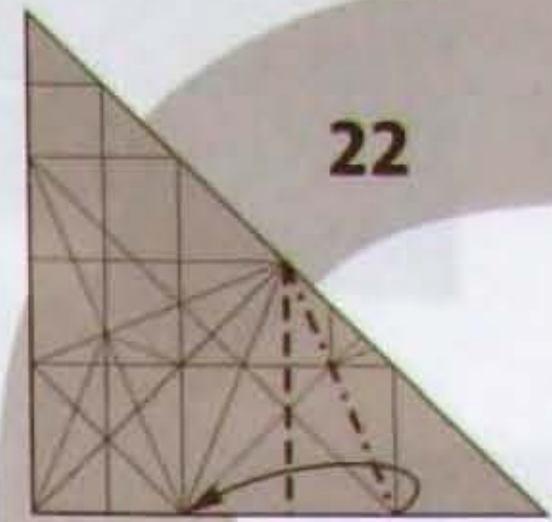

折り筋で開いてつぶす

20

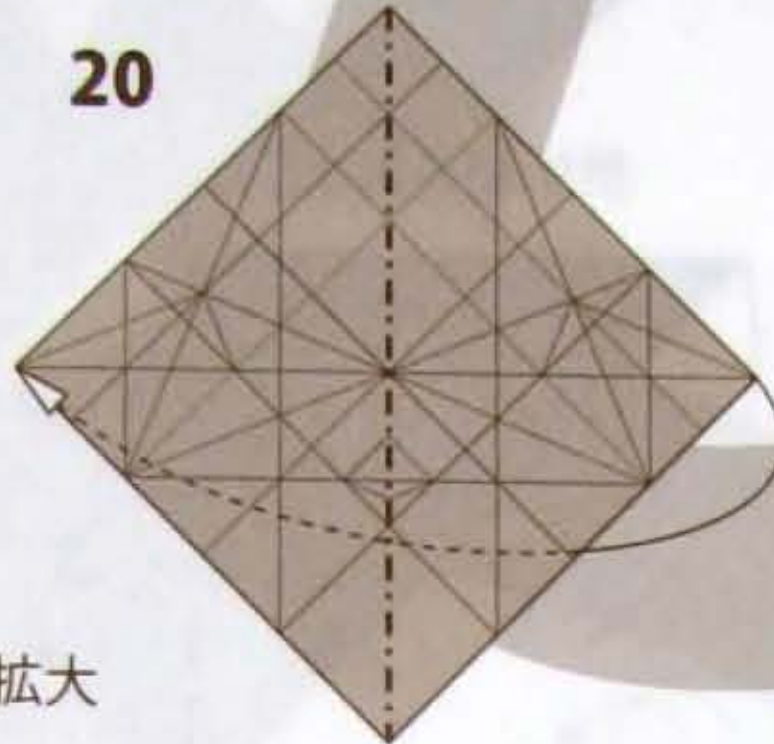

向こう側に半分に折る

21

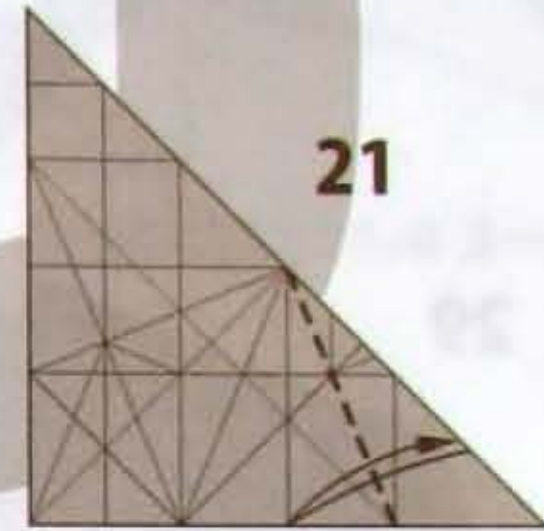

フチを折り筋に合わせて折り筋を付ける

17

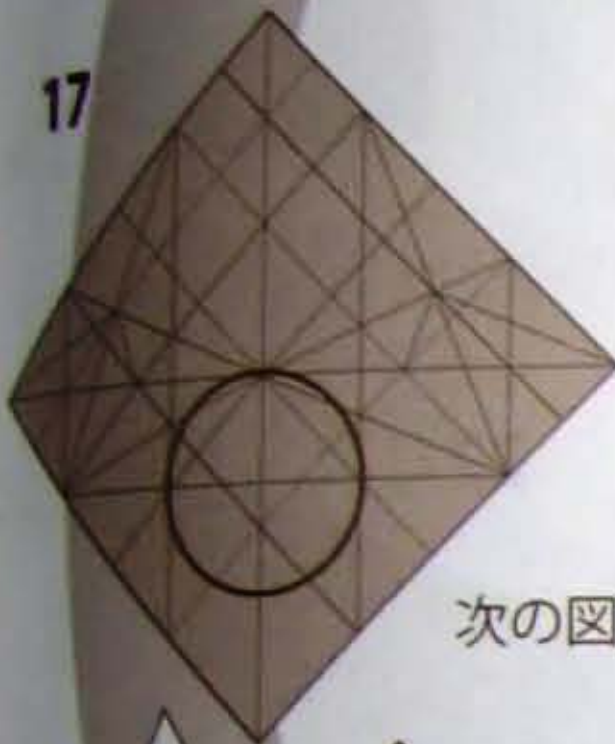

次の図で円内部を拡大

16

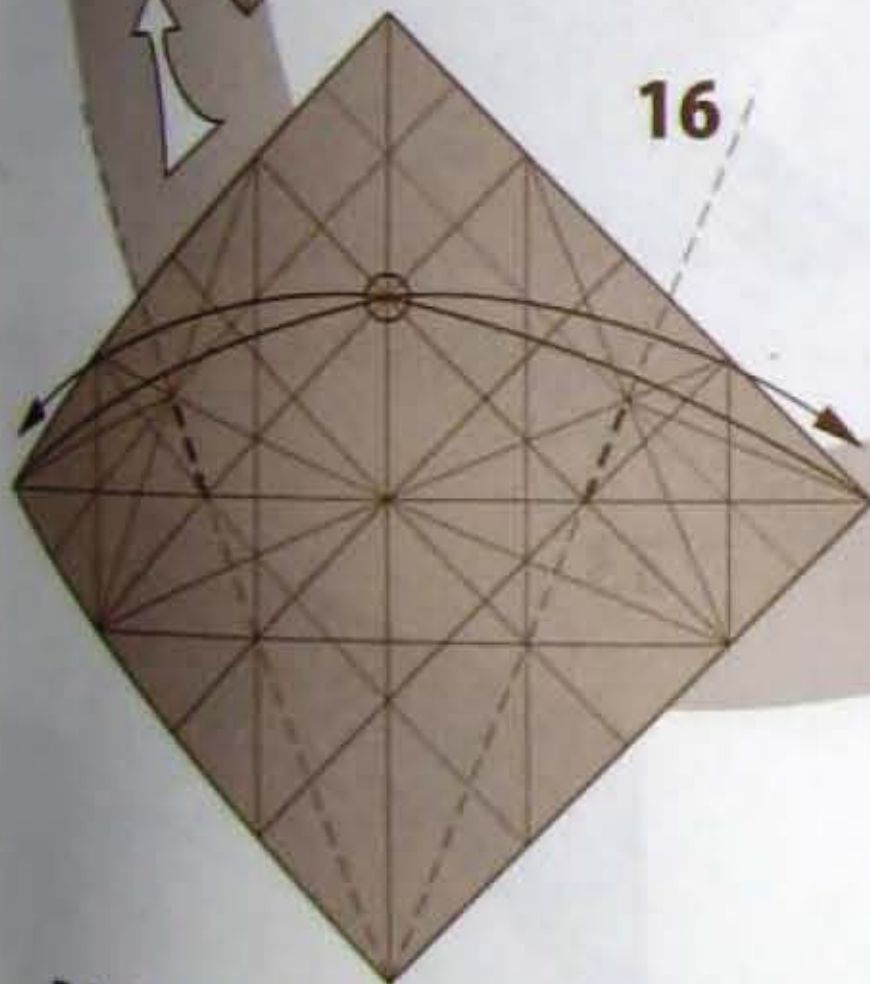

角を中心に合わせて
太い点線部分だけに折り筋を付ける

15

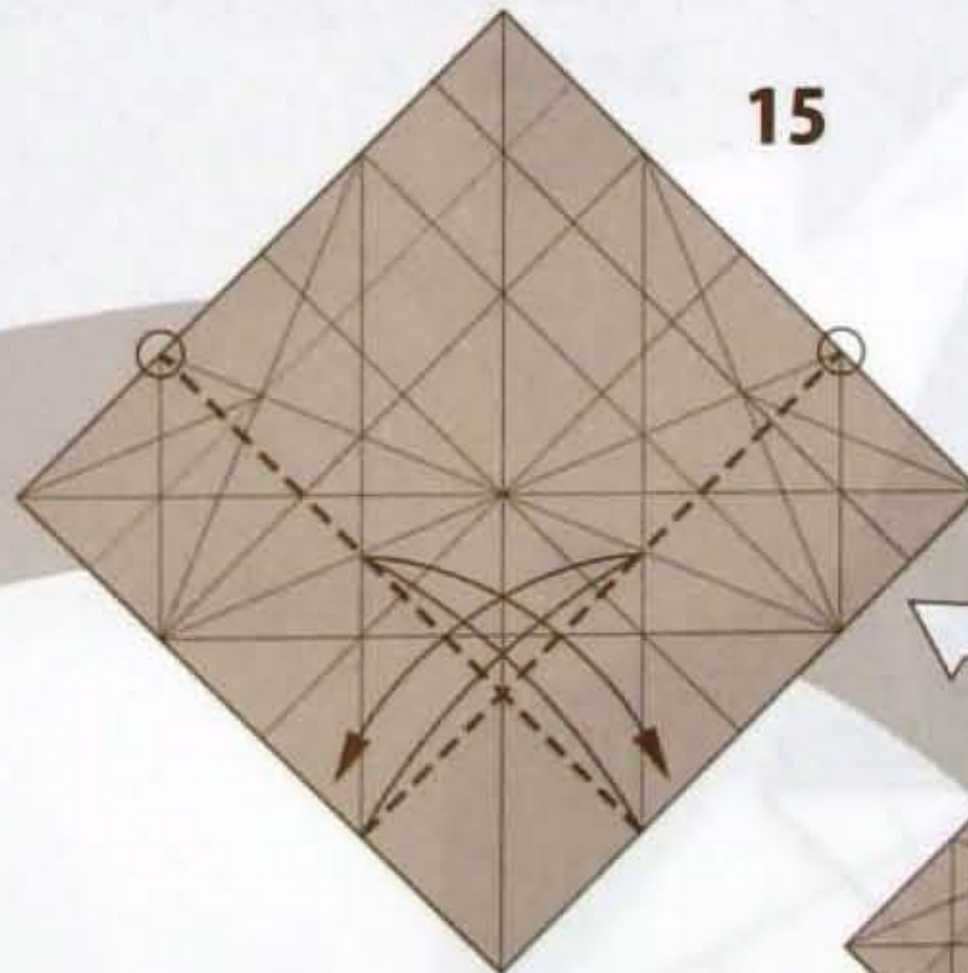

○を目印に折り筋を付ける

14

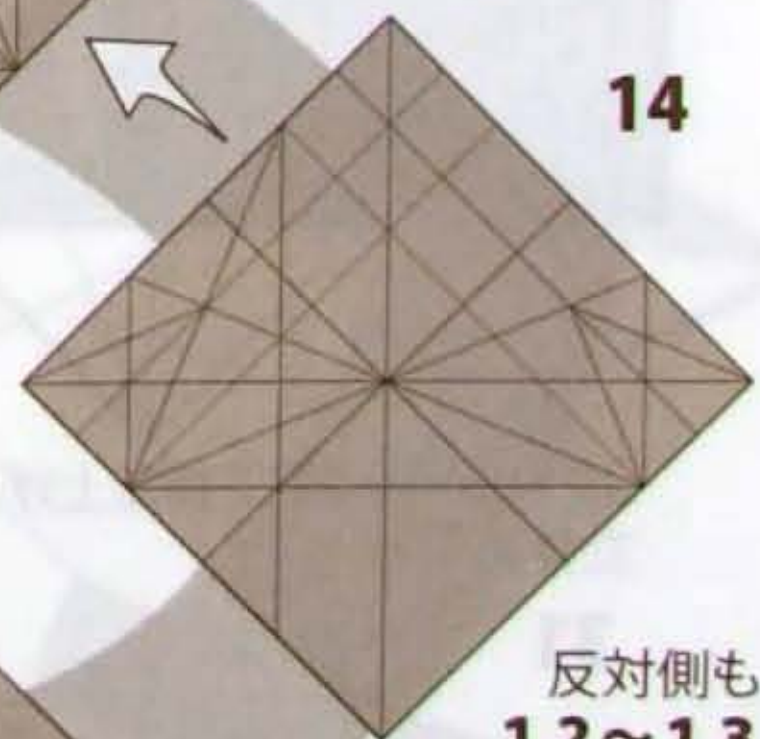

反対側も
12~13

11

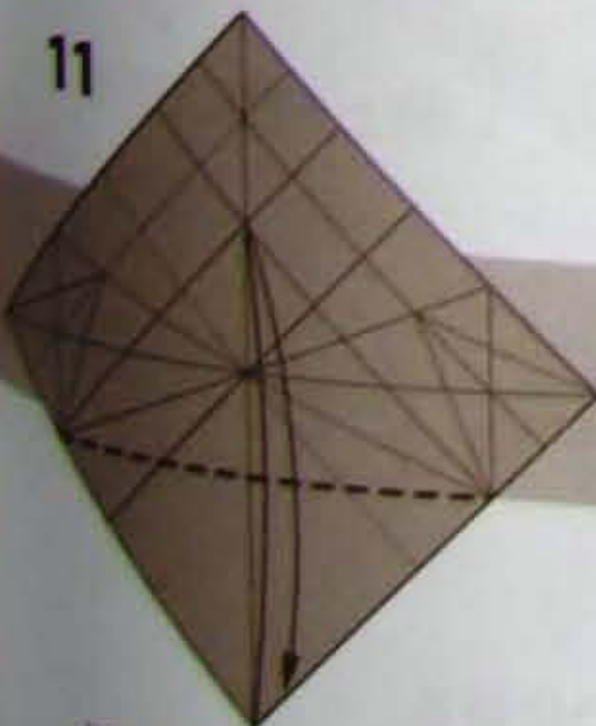

折り筋を付ける

12

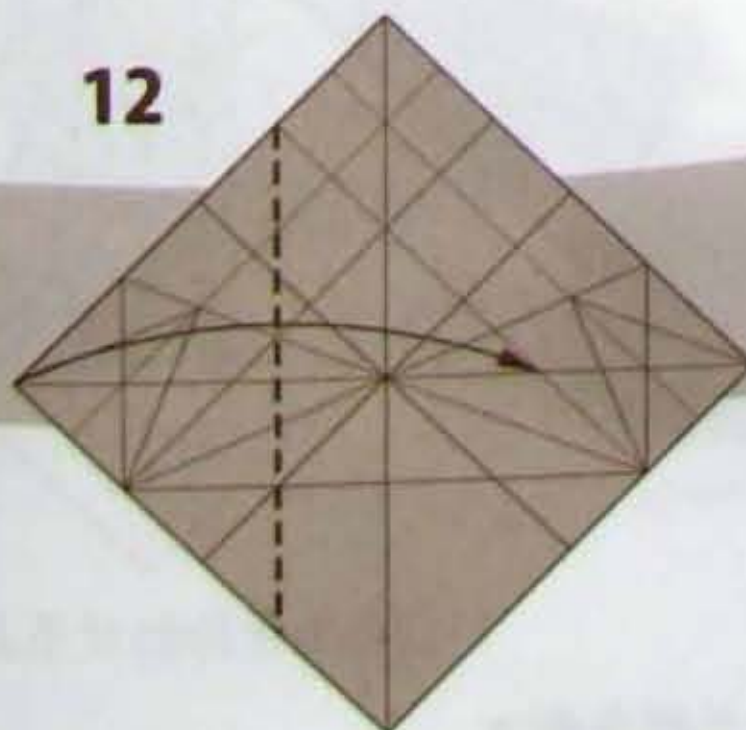

13

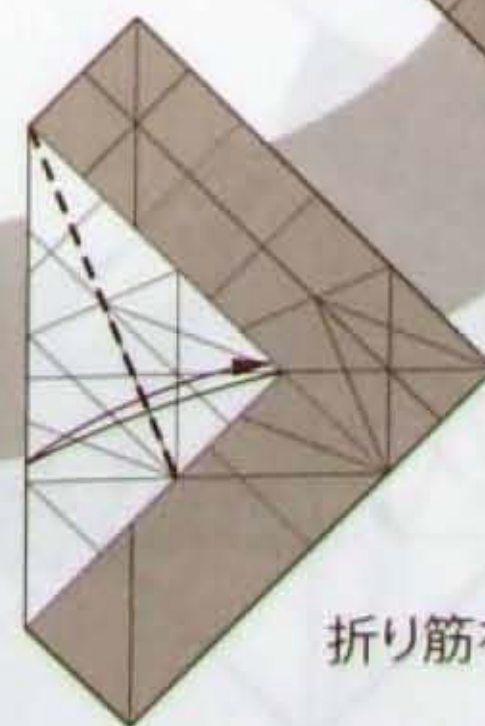

折り筋を付ける

38

akuro

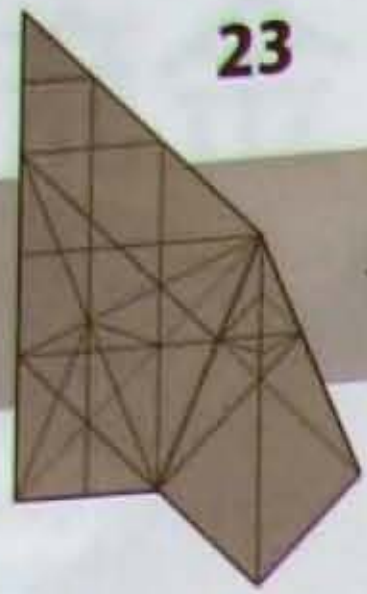

23

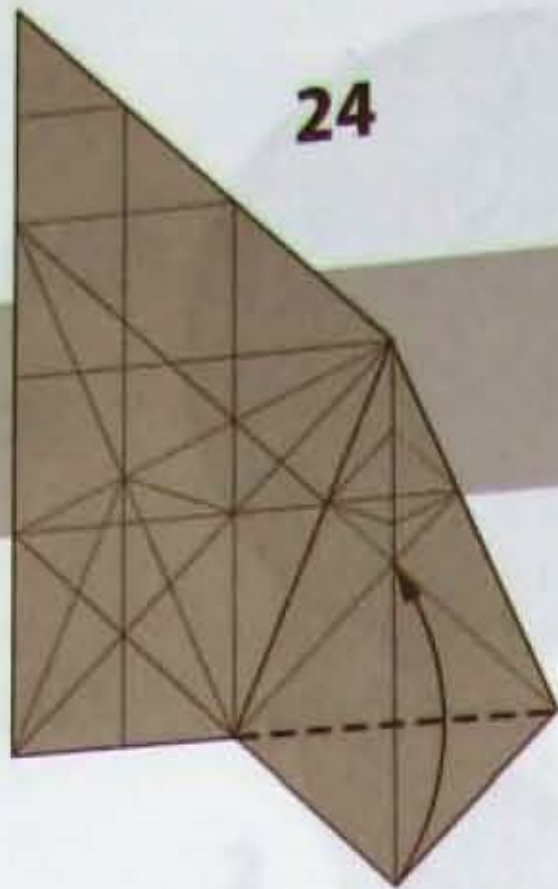

24

折り上げる

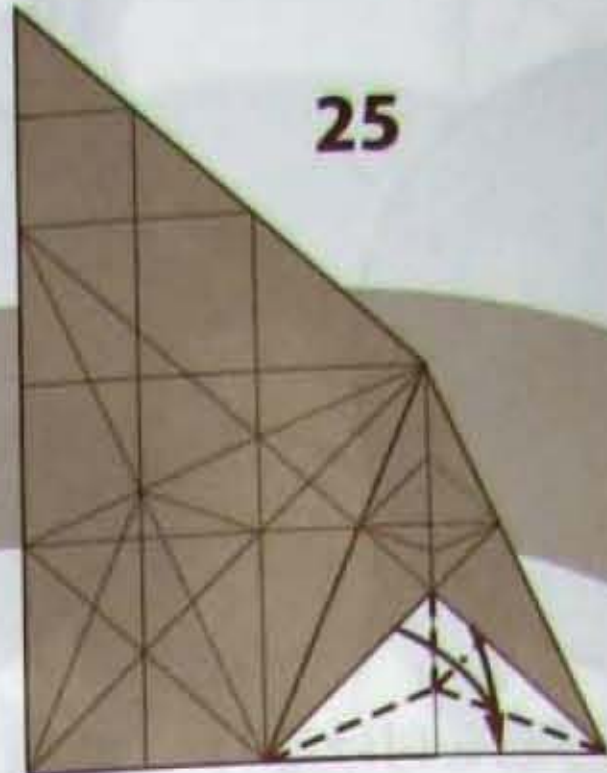

25

つまむように折る



26

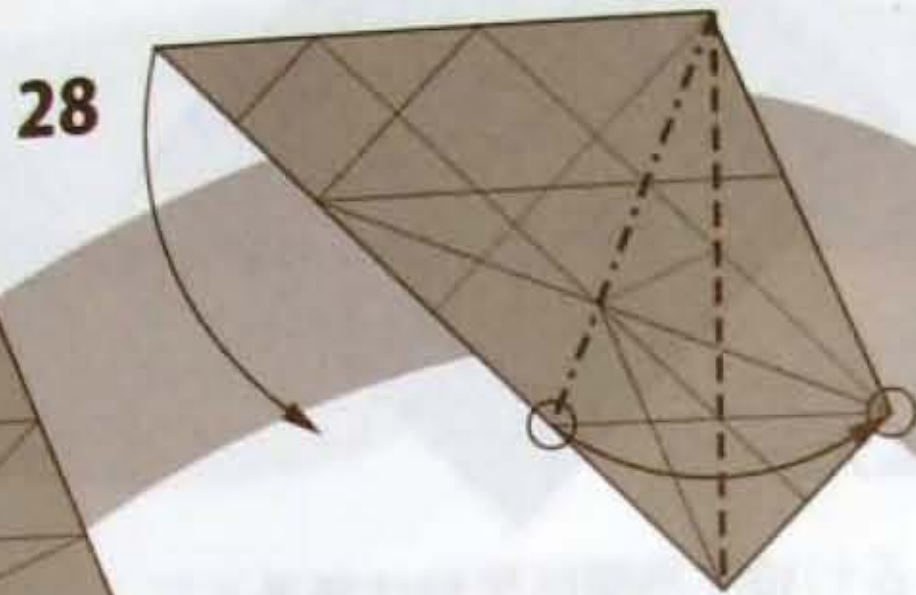

28

○同士を合わせるように折る
面が回転する

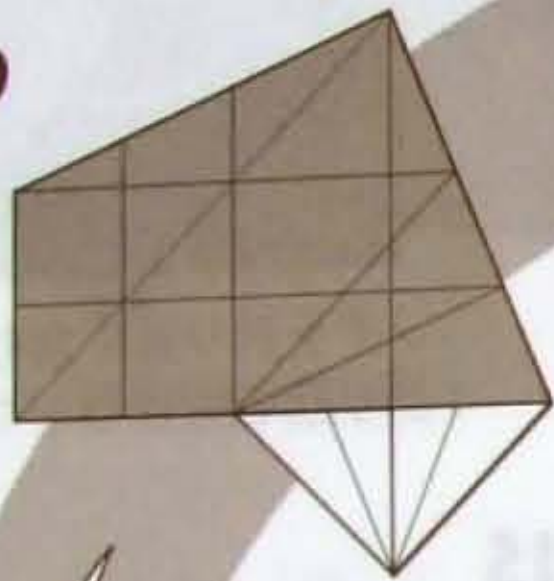

29

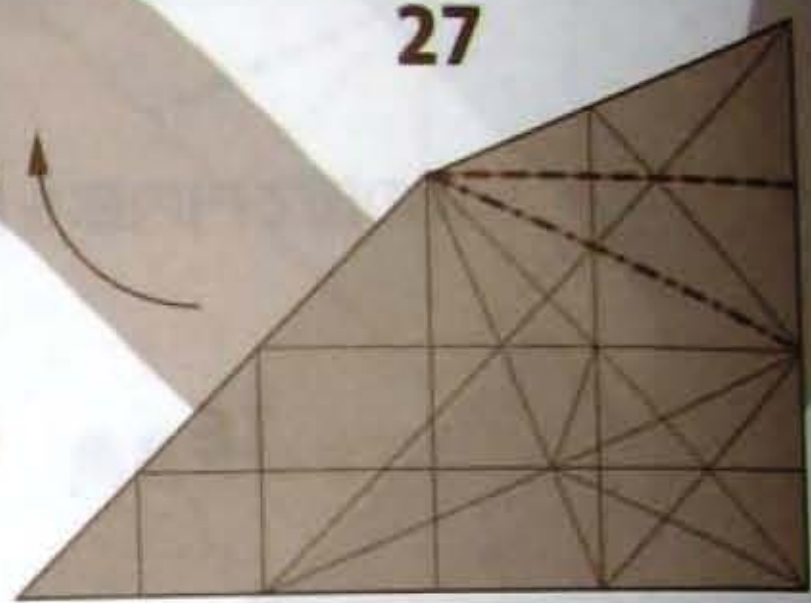

27

両面で回転させるように内側へ折る

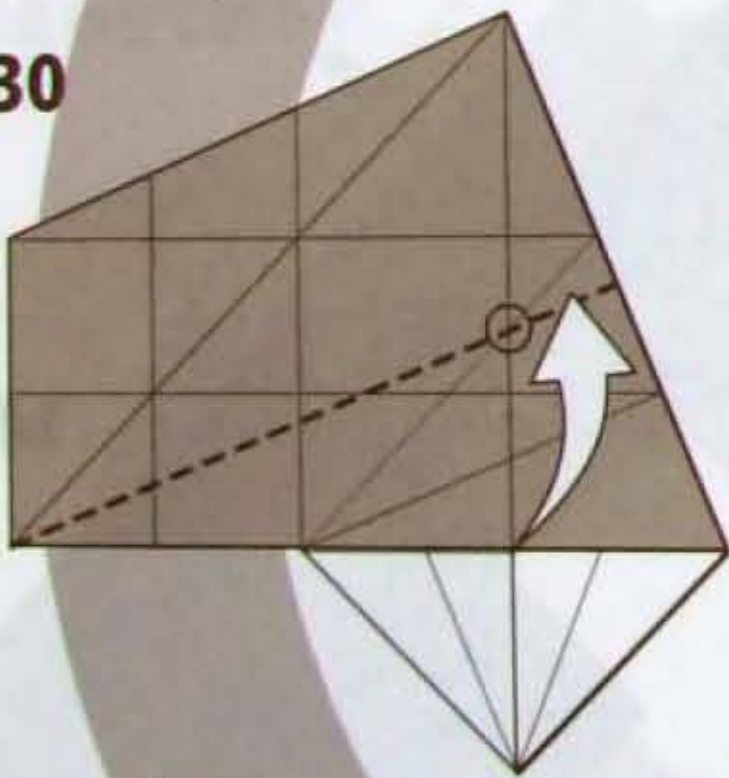

30

上一枚を折り線で持ち上げる
立体になる

31

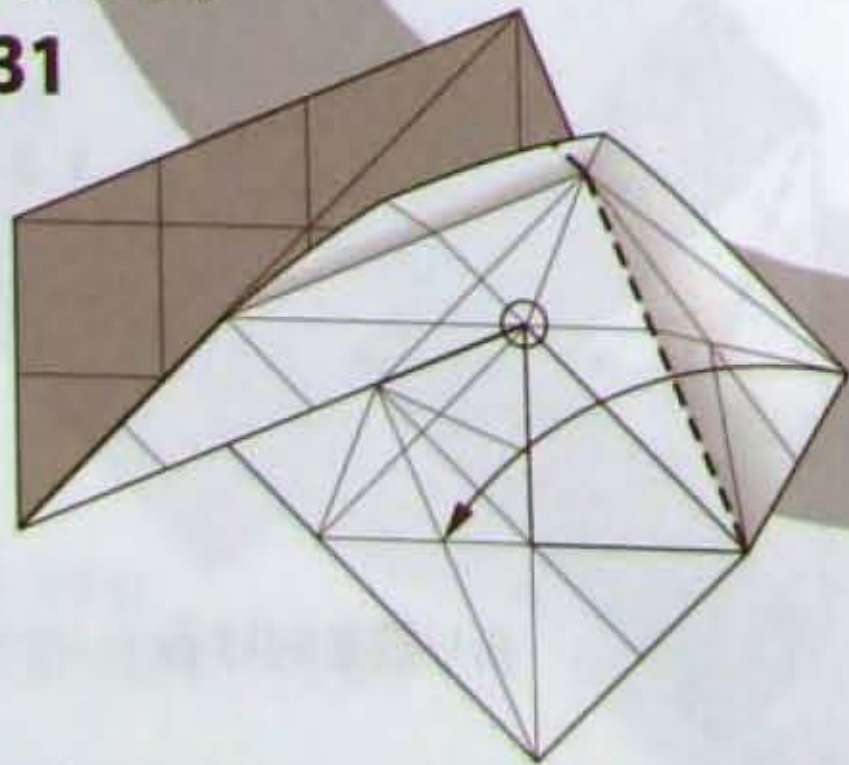

○から平らになるように折っていき、行き止まったら紙を倒す

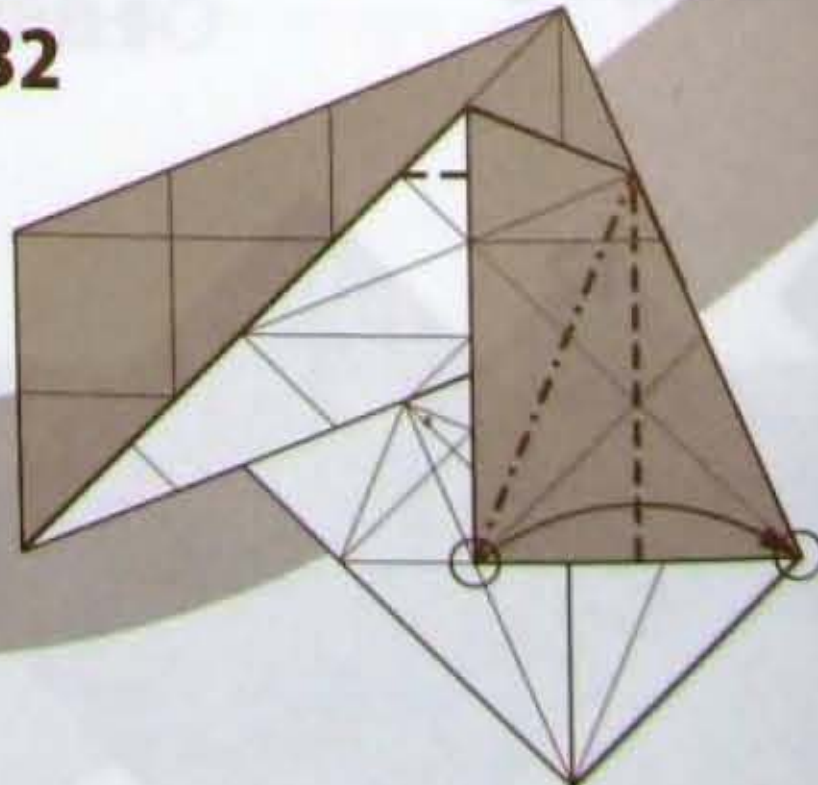

32

○同士を合わせるように折る

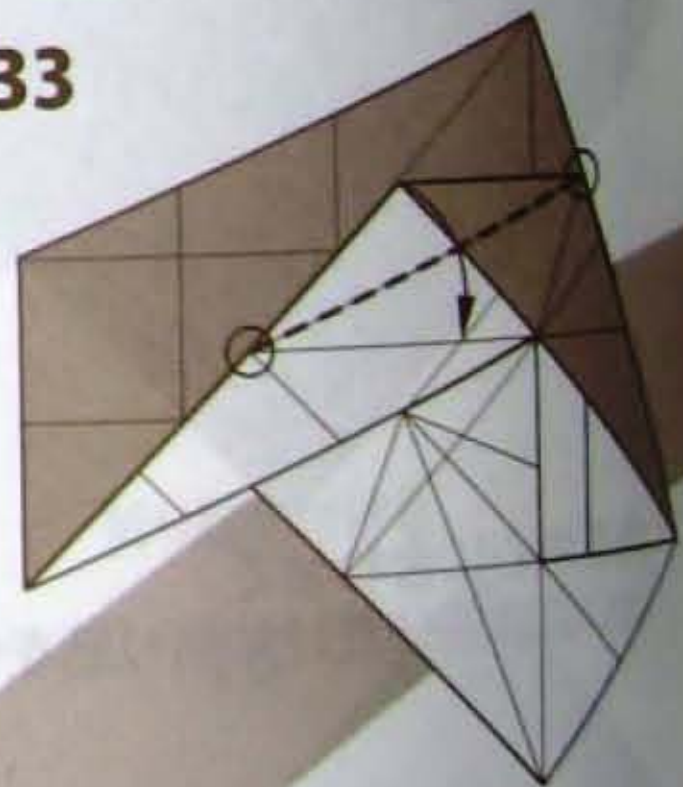

33

○同士を結んで折る



40

一番手前の三



39

30~37と

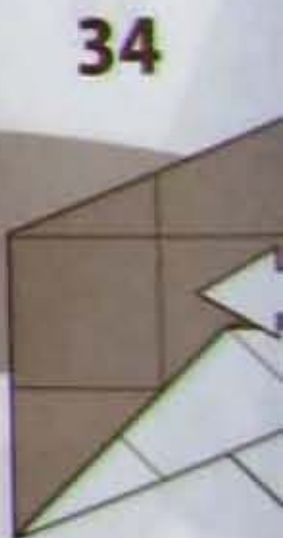

34

濃い灰色
両側に引

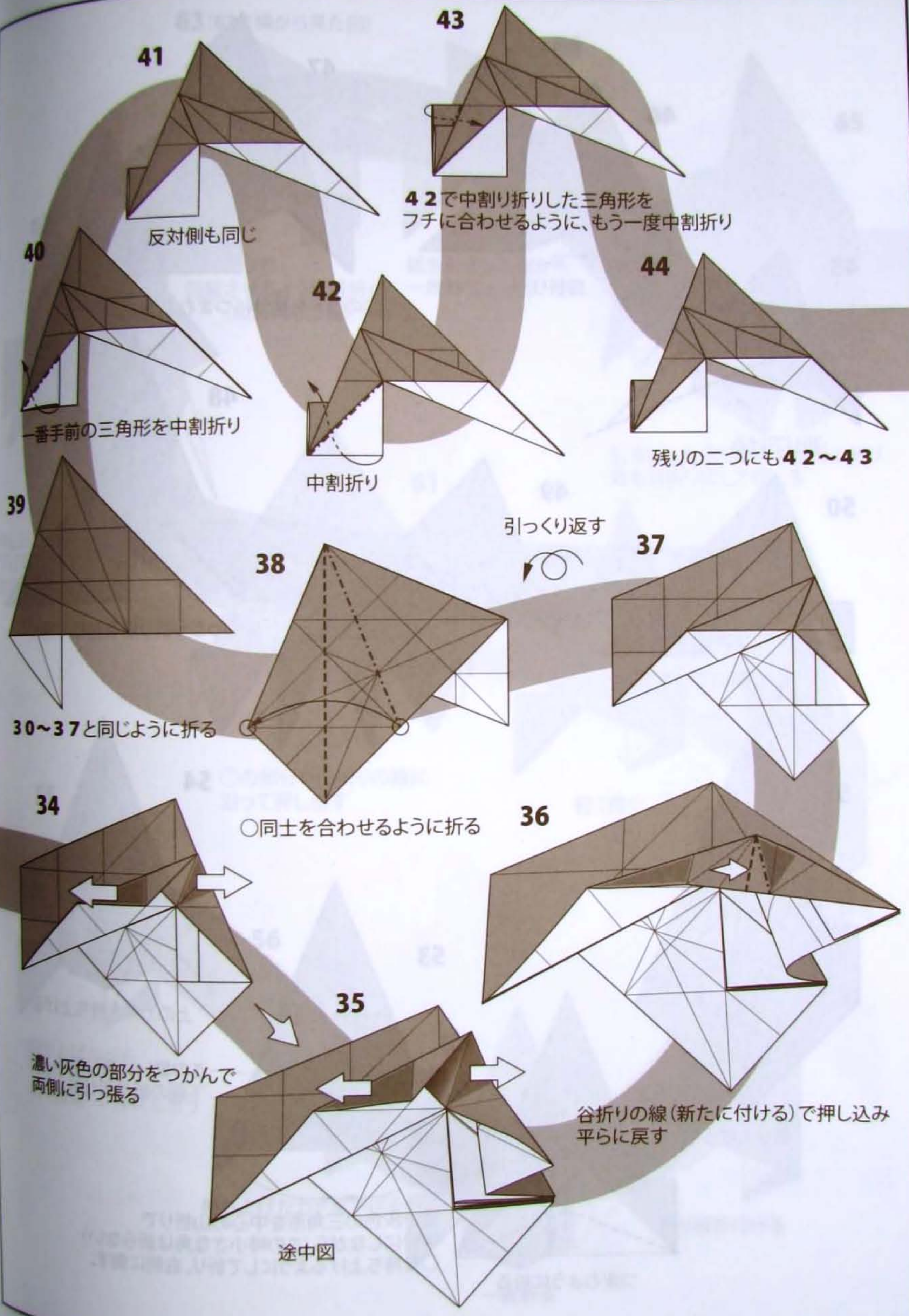

41

反対側も同じ

43

42で中割り折りした三角形をフチに合わせるように、もう一度中割り折り

40

一番手前の三角形を中割り折り

42

中割り折り

44

残りの二つにも42~43

39

引っ繰り返す

38

37

30~37と同じように折る

○同士を合わせるように折る

34

36

濃い灰色の部分をつかんで両側に引っ張る

35

谷折りの線(新たに付ける)で押し込み平らに戻す

途中図

45

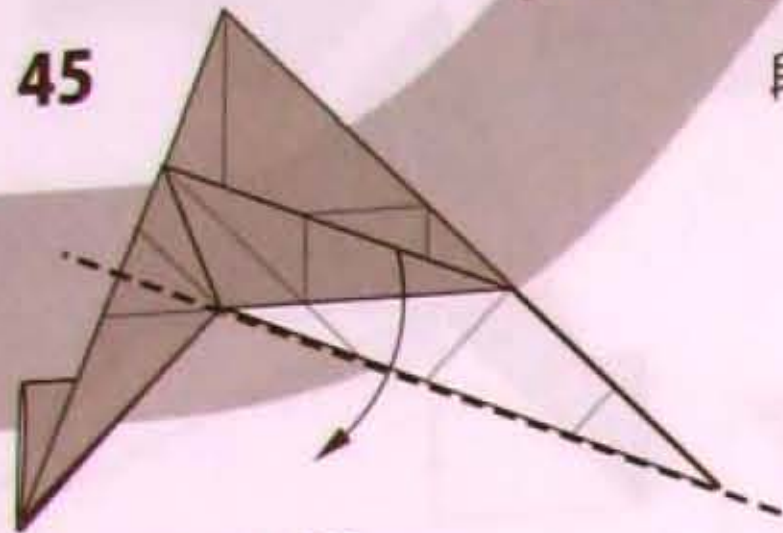

折り下げる

46

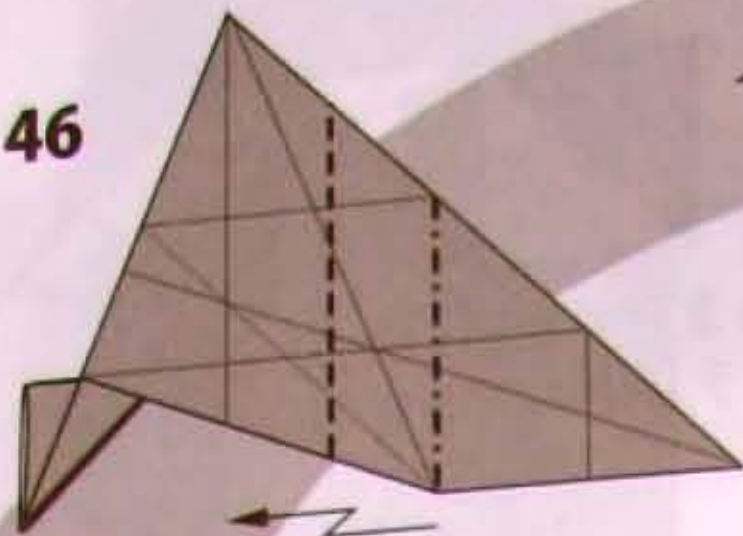

段折り

47

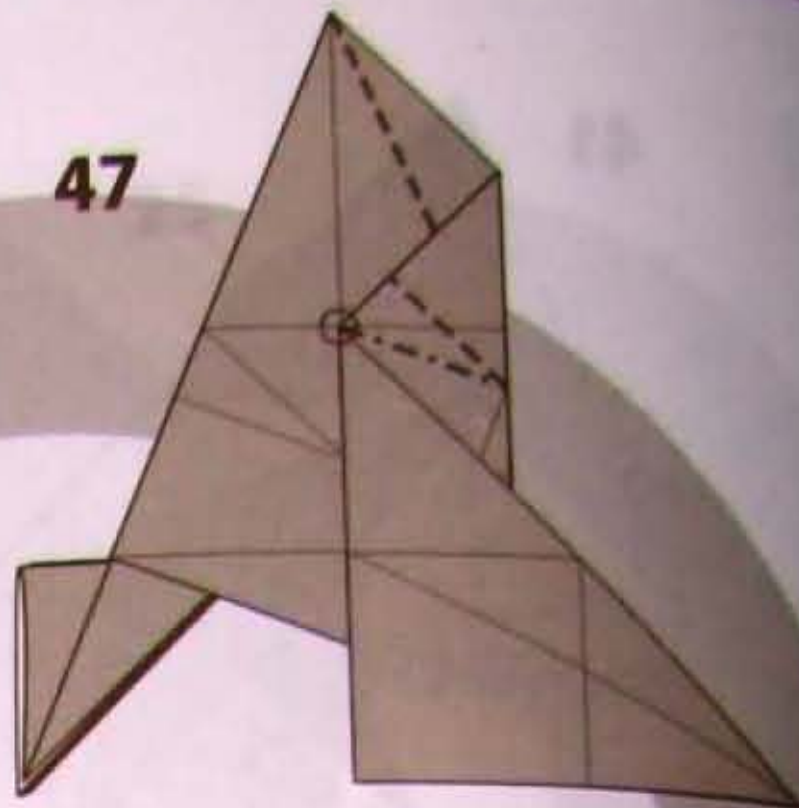

○のカードを半分につまむようにして折る

48

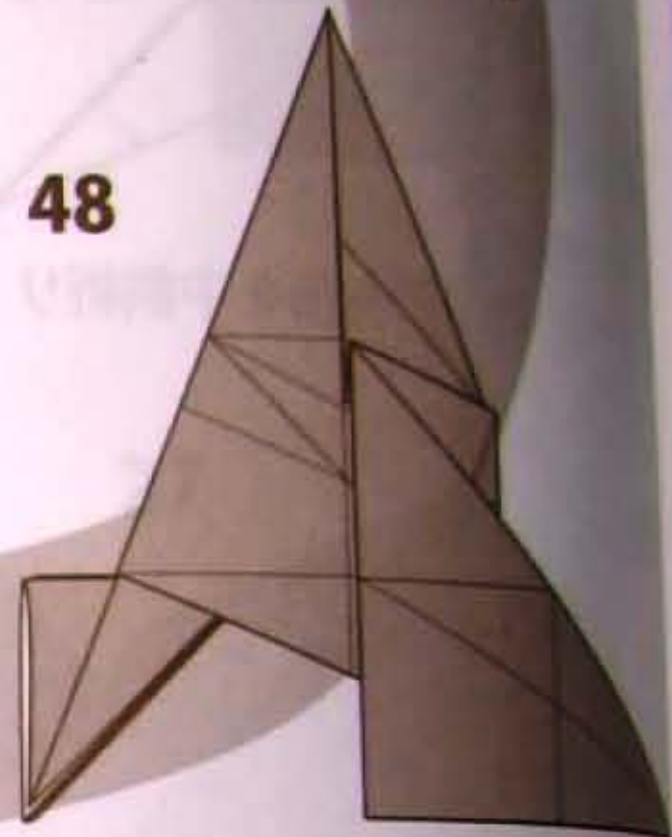

しっかり折り筋を付けて開く

50

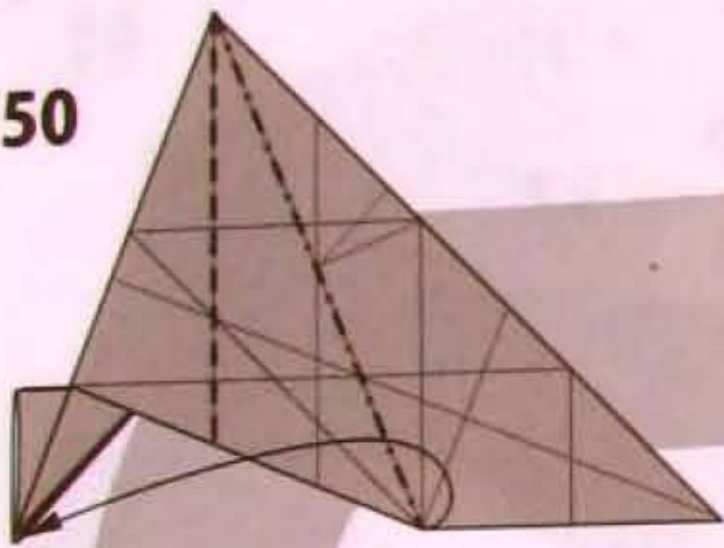

開いてつぶす

49

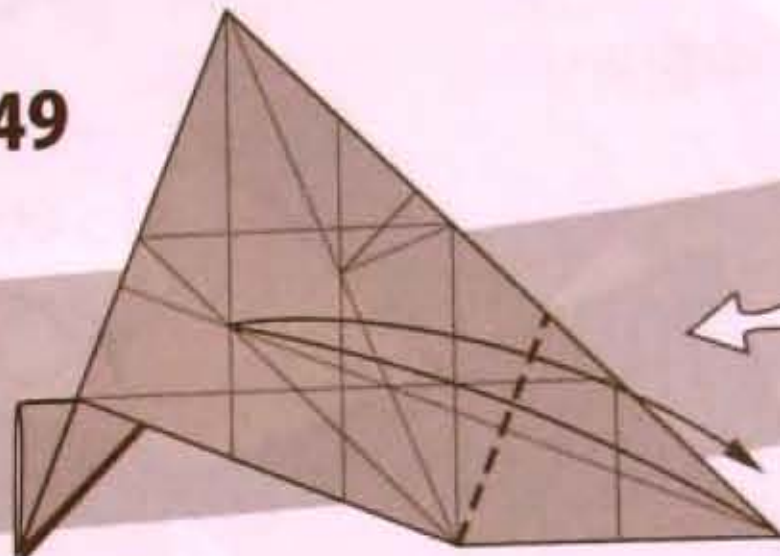

折り筋を付ける

51

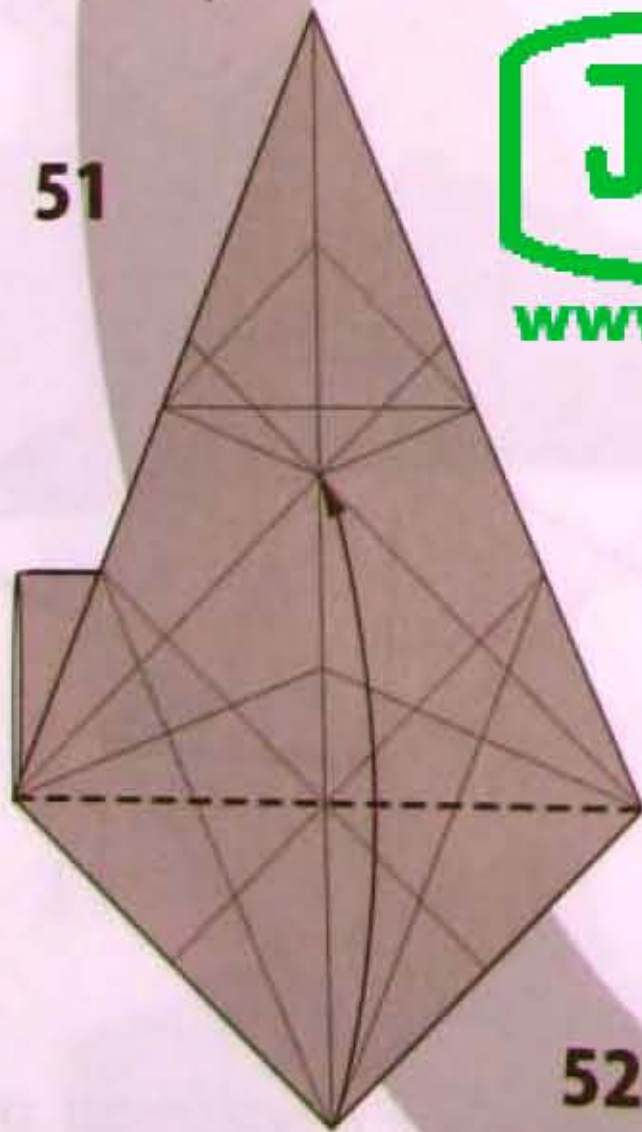

折り上げる

52

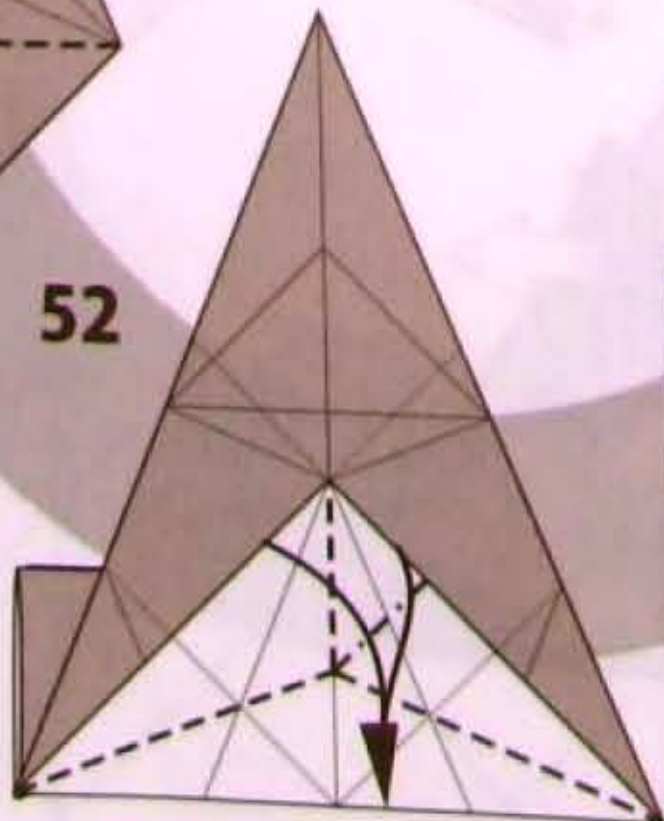

つまむように折る

53

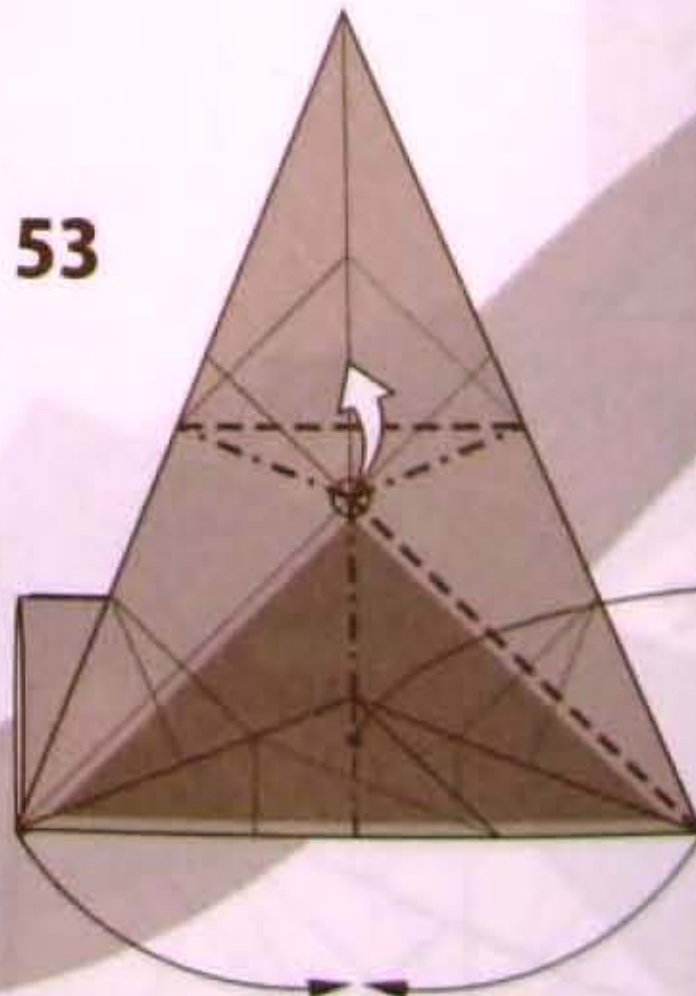

濃い灰色の三角形を中心の山折り
半分にしながら(この時小さな角は折らない)
○を持ち上げるようにして折り、右側に倒す。

54

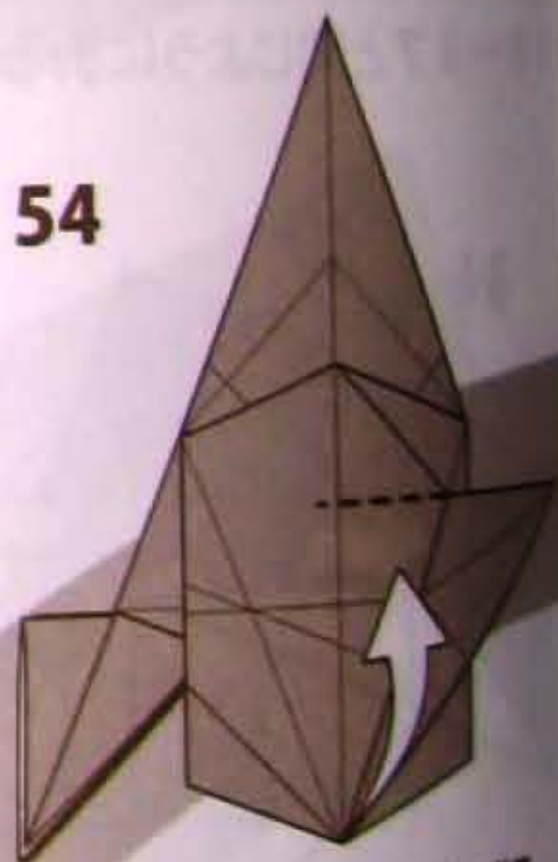

上のカードを持ち上げる

この細かい山折り線は
下側の紙の折り線

55



持ち上
外側の
折り線

Japão Burajirujin

www.japaoburajirujin.blogspot.com

63 (62を横から見た図)

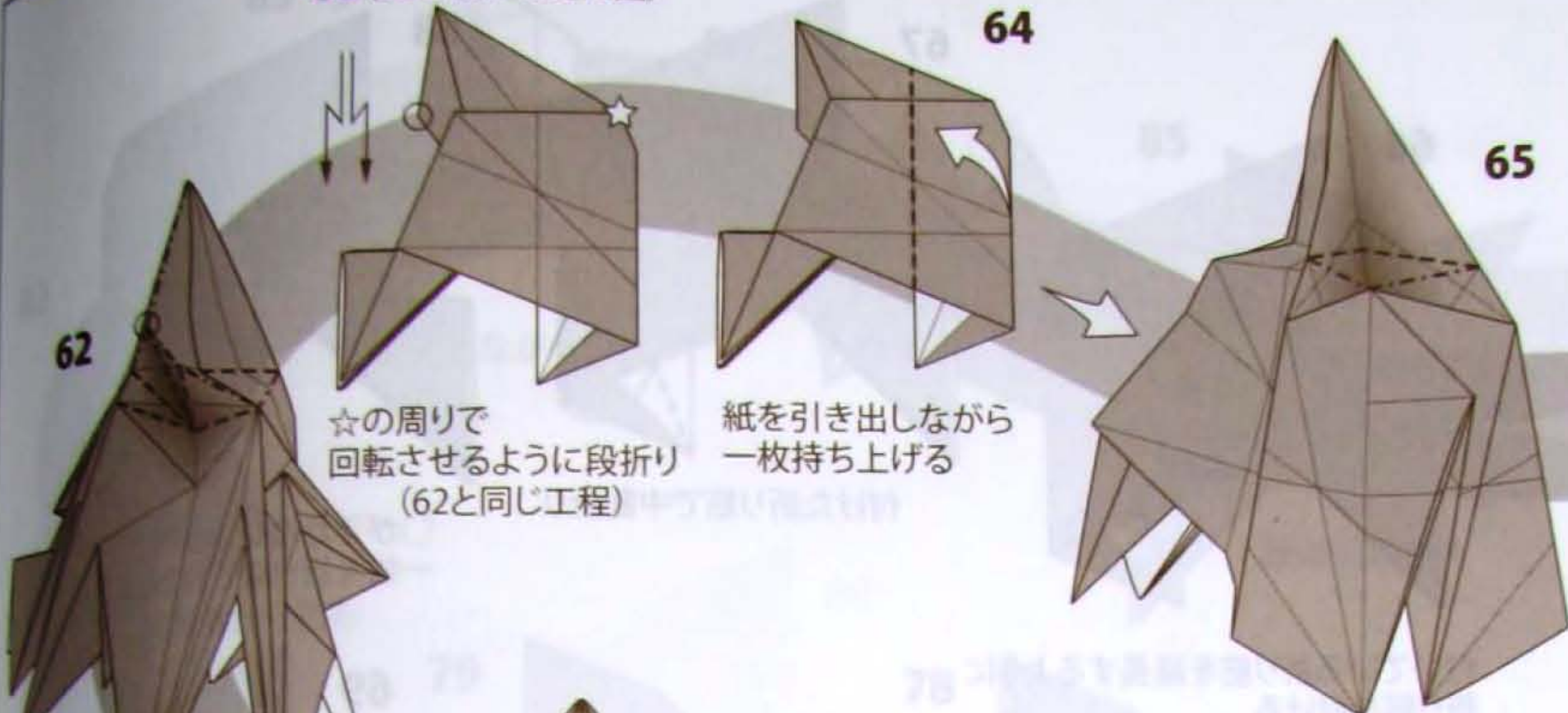

☆の周りで
回転させるように段折り
(62と同じ工程)

紙を引き出しながら
一枚持ち上げる

引き出した折り線の手前を山折り
奥を谷折りにして閉じる

押し出した○の形が崩れないよう
下げながら折り筋通りに折る
次の図も参考にする

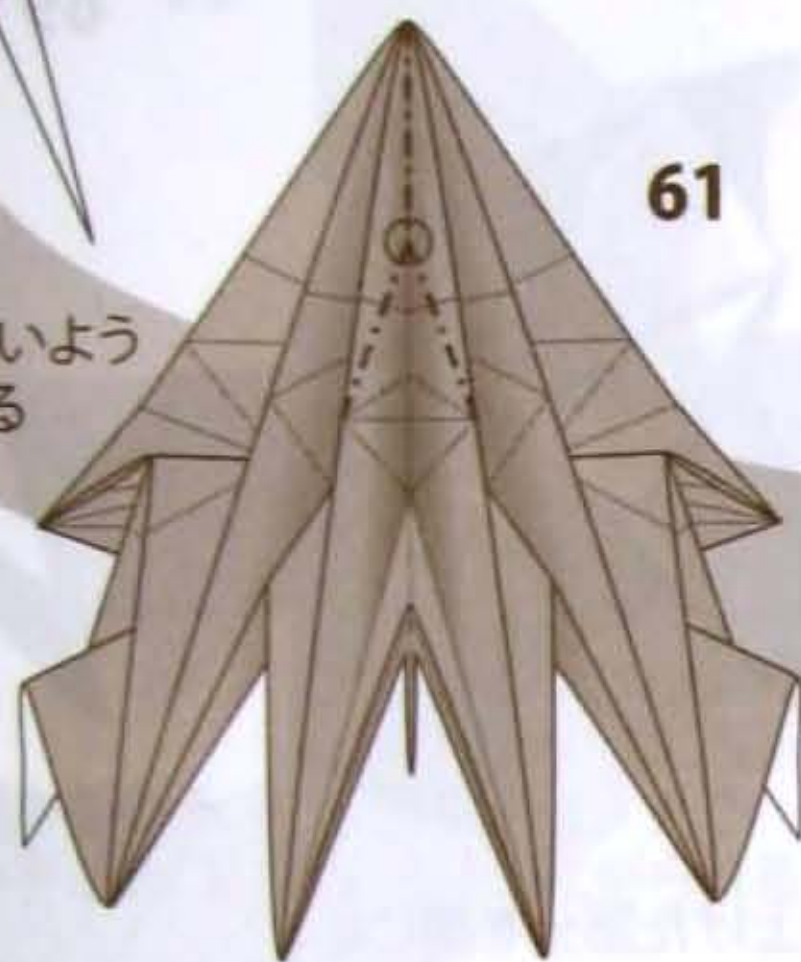

○の部分を山折りの線に
沿って押し出す

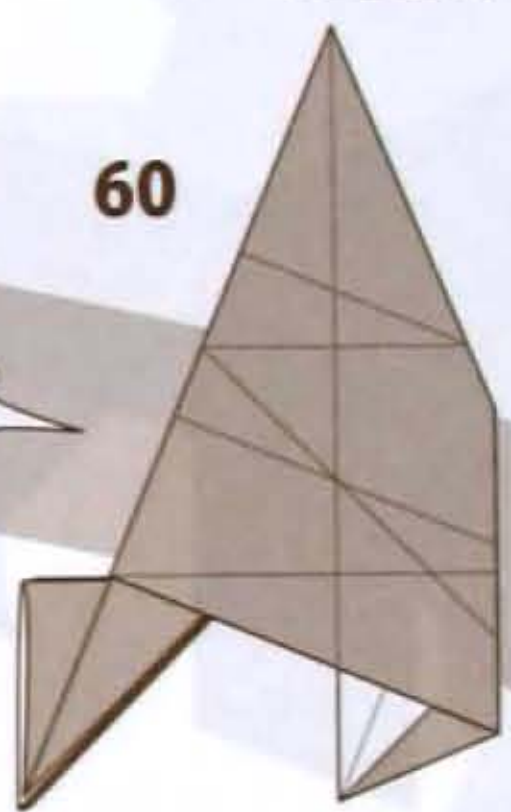

軽く開く

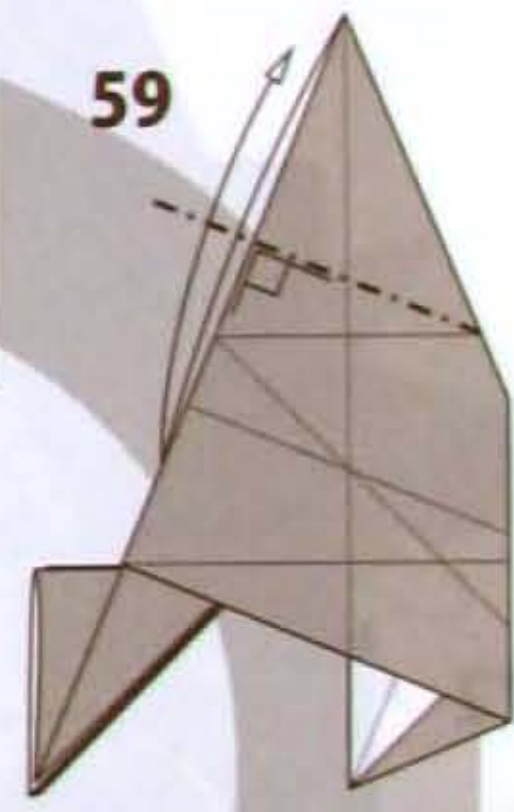

反対側にも付ける

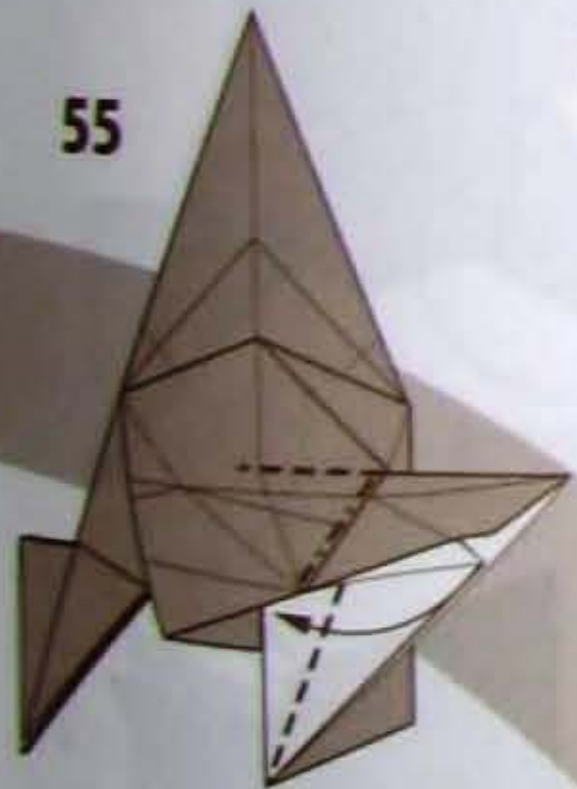

持ち上げながら
外側の部分を
折り筋通りに中にしまう



持ち上げたカドを下げる



一枚折る

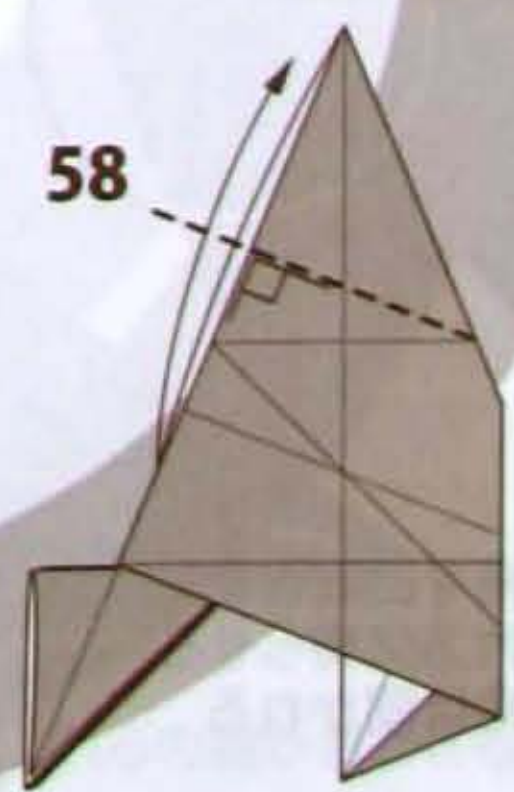

折り線を付ける

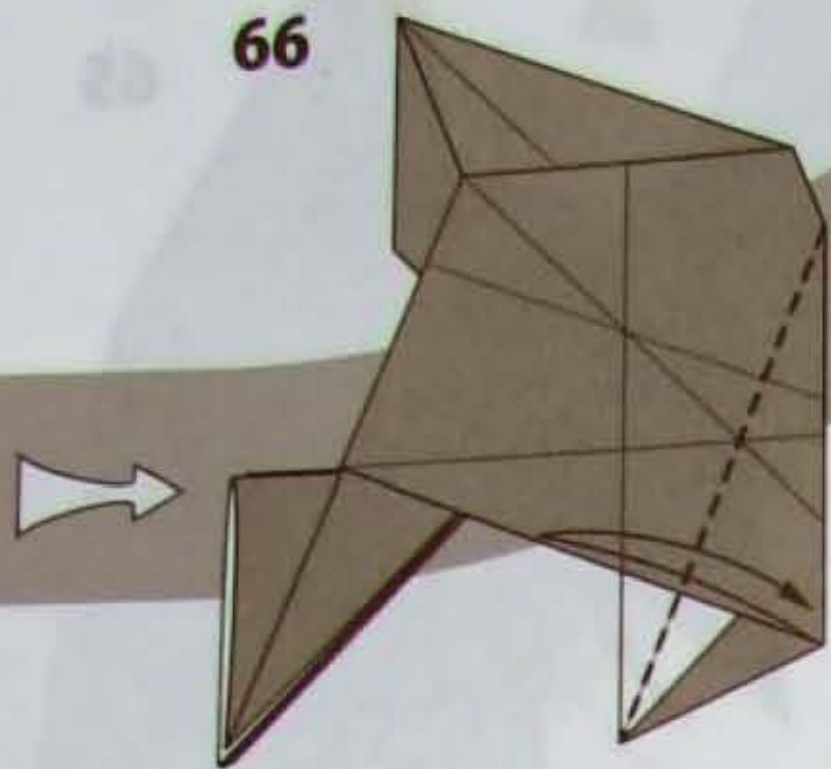

付いている折り筋を延長するように折り筋を付ける

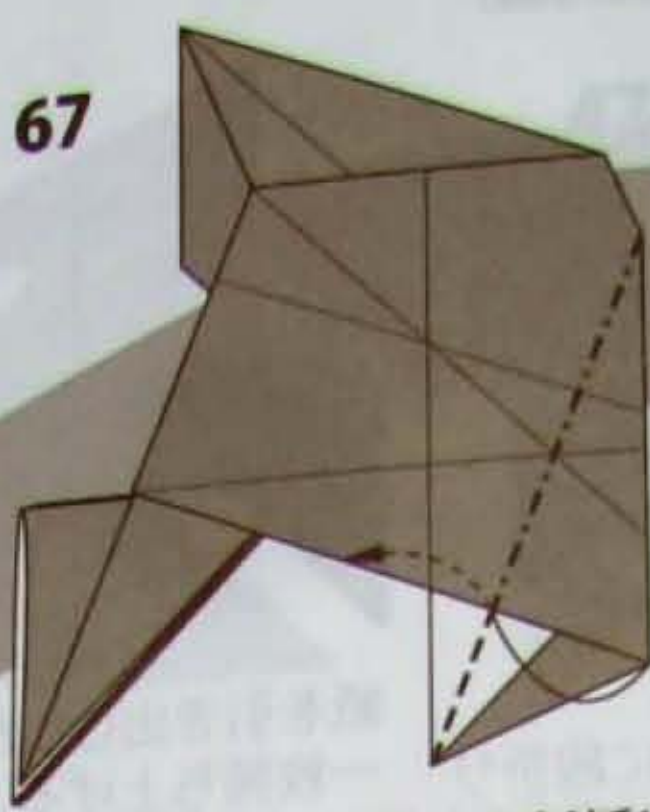

付けた折り筋で中割折り

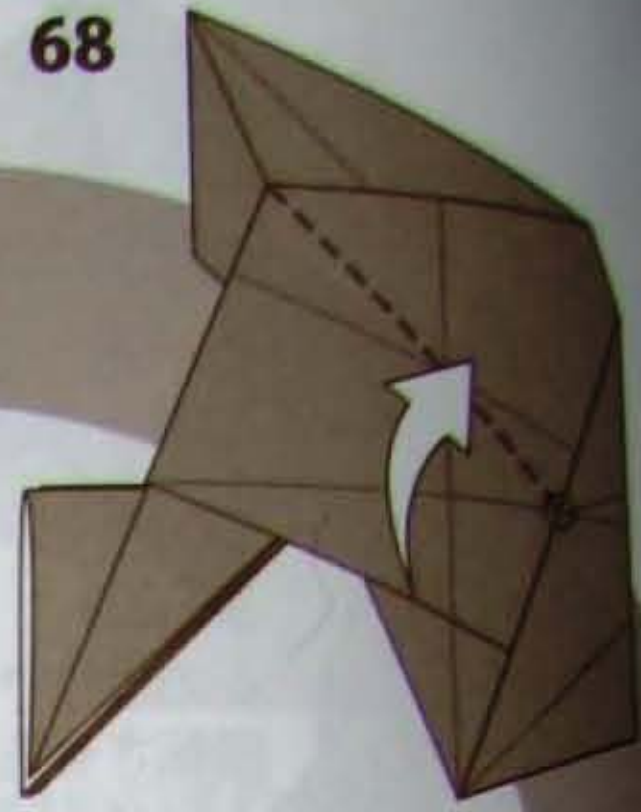

○が浮かないよう押さえ一枚を折り線で持ち上げる

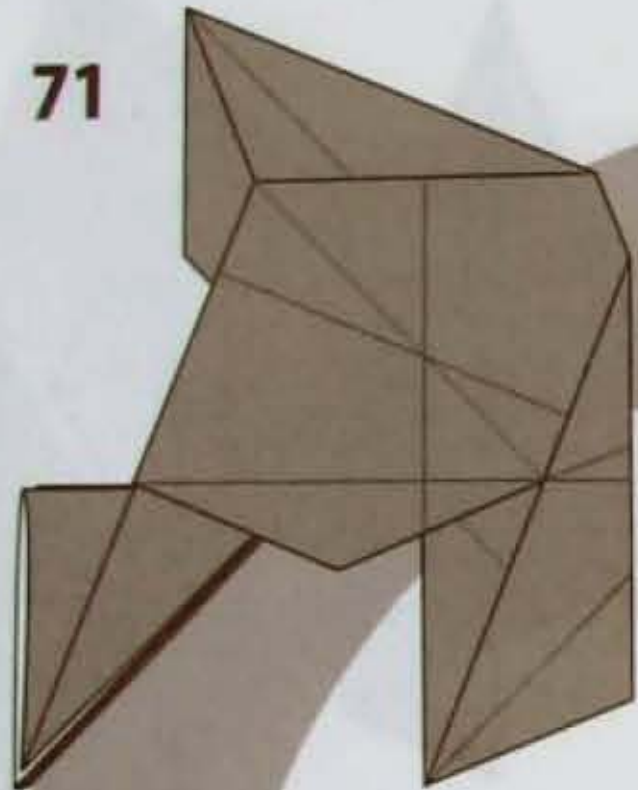

反対も同様に折る

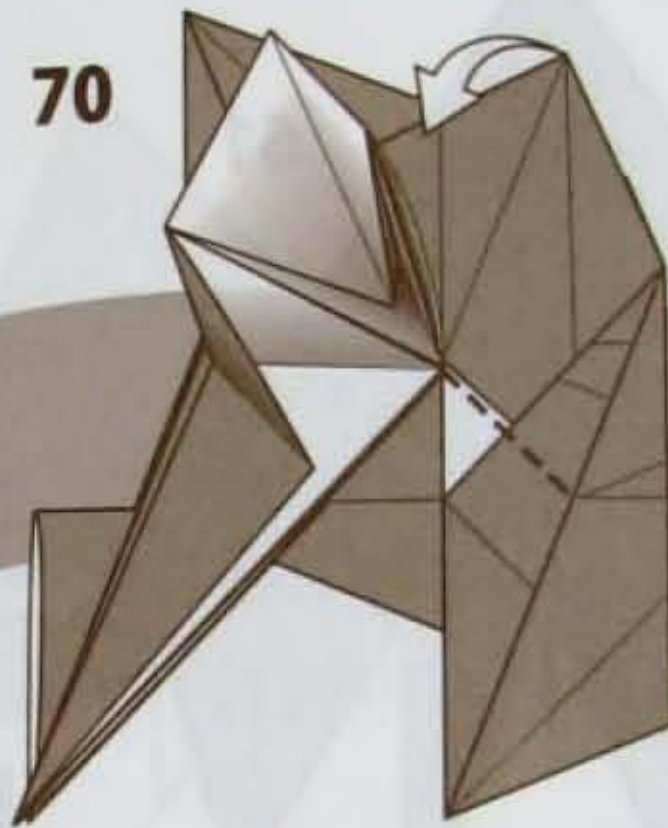

持ち上げた部分を閉じる



そのまま折り線通りに折り下げながら○から平らになるように折っていく



内部図

○を中心に角を回転させるように折る
内部の紙は片方に寄らせる
回転させた角は開かれる

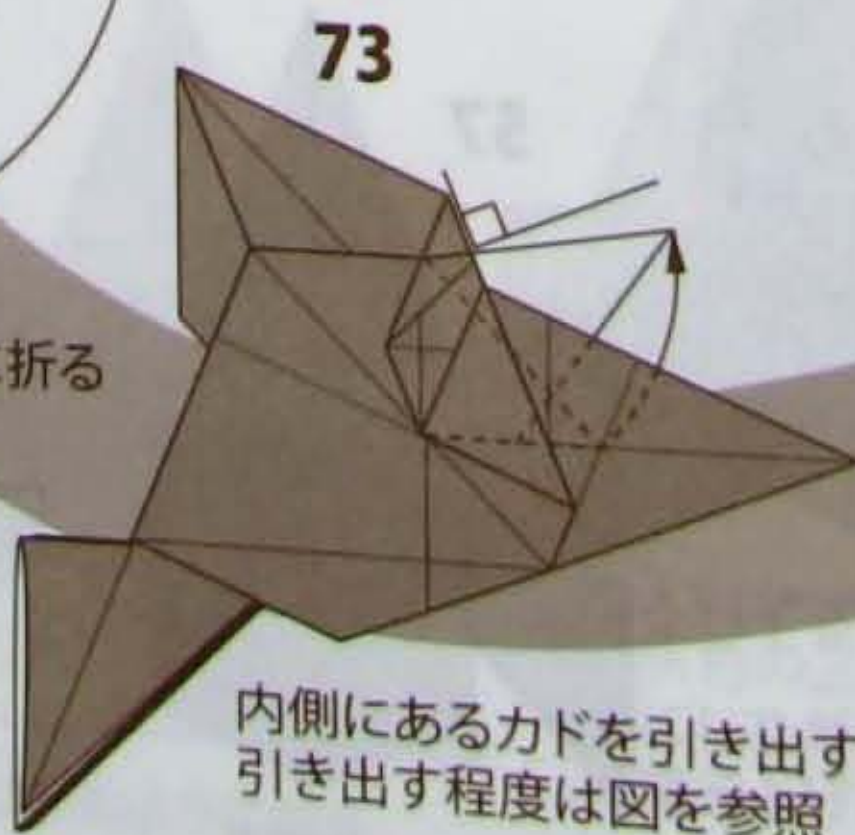

内側にあるカドを引き出す
引き出す程度は図を参照

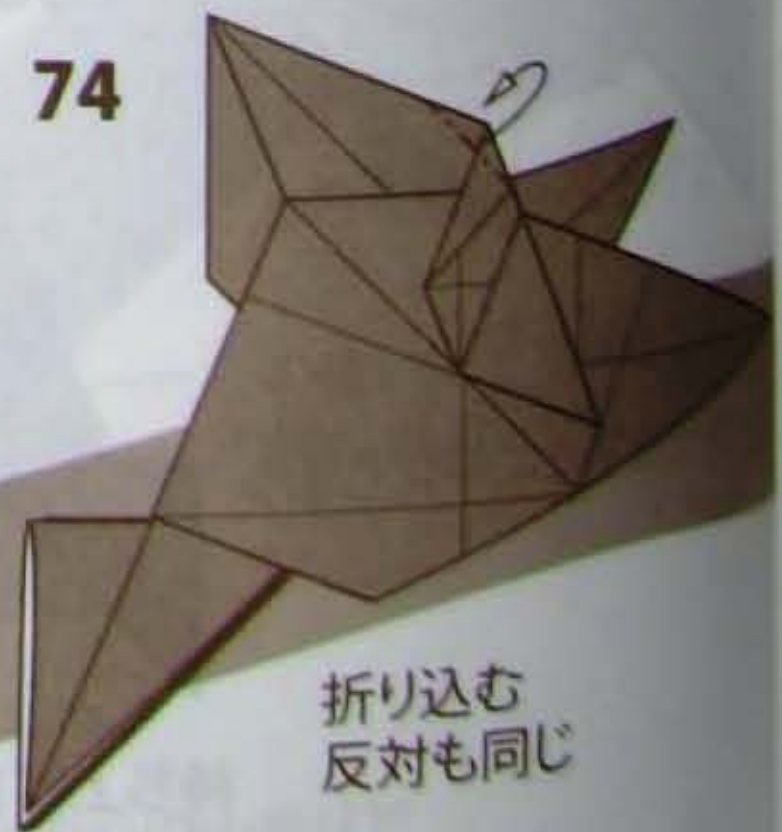

折り込む
反対も同じ

82



次の図

81



8

75



83

84

85

82

引き寄せながら折る

反対も79~84

次の図は反対側から見る

79

78

反対も75~77

かぶせ折り

○を中心にして上側だけ
回転させるように段折り
(下側2枚はフチで
ずれるように折られる)

77

80

これらの辺を
合わせるように折り込む

次の図で拡大

76

75

(2)これらの線が合わさるように折る

○の部分を開く

(3)閉じる

(1)この線で山折り(○は75と同じ位置)



86

図を参考にして折り込む
反対も同様に折る

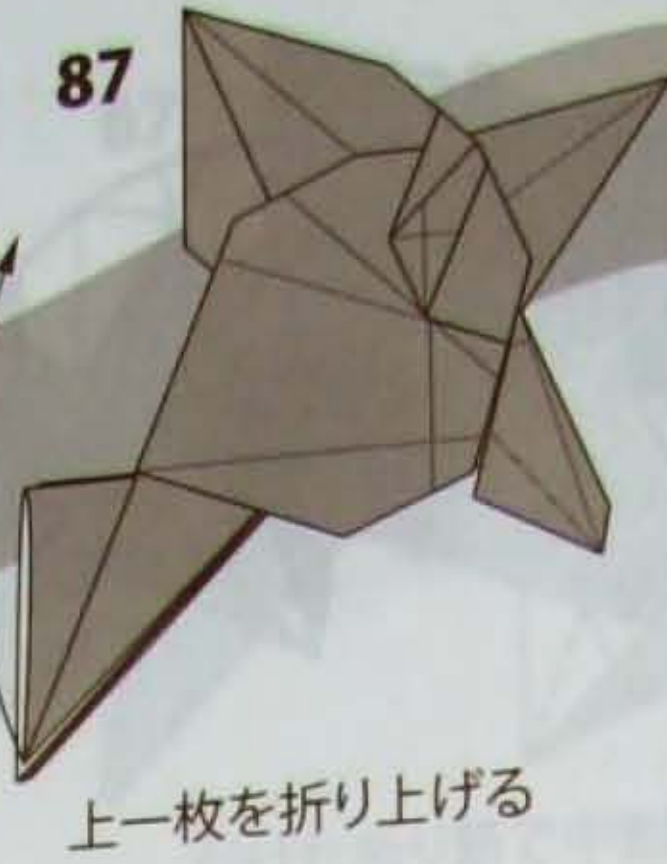

87

上一枚を折り上げる

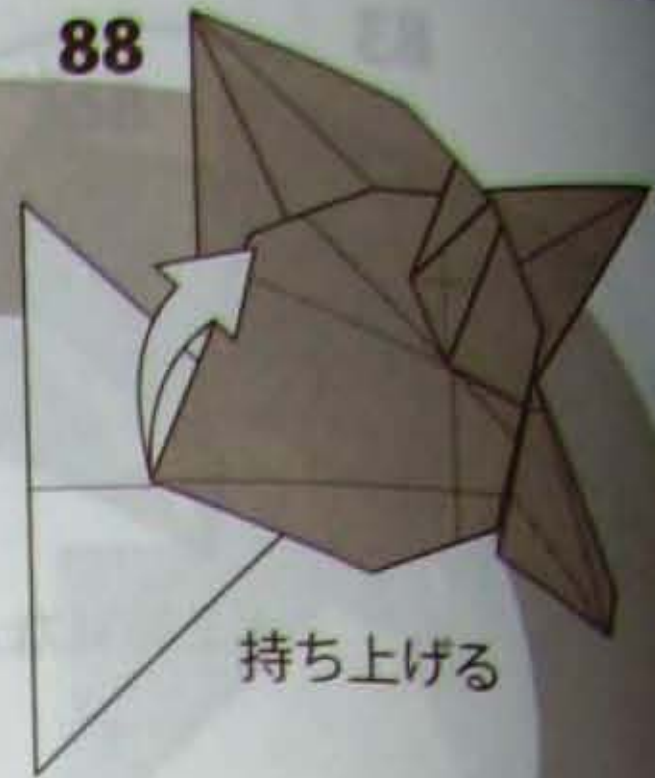

88

持ち上げる

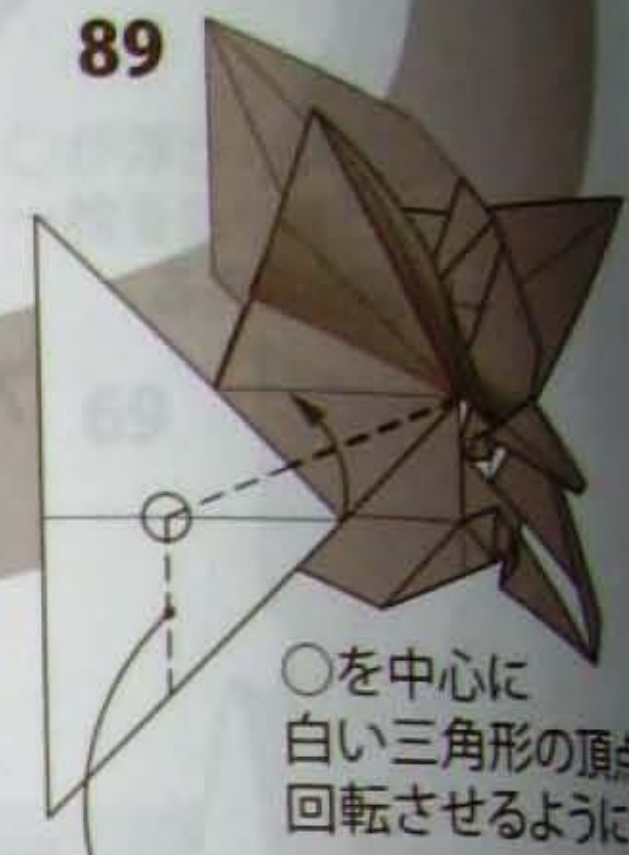

89

○を中心に
白い三角形の頂点を
回転させるように折る

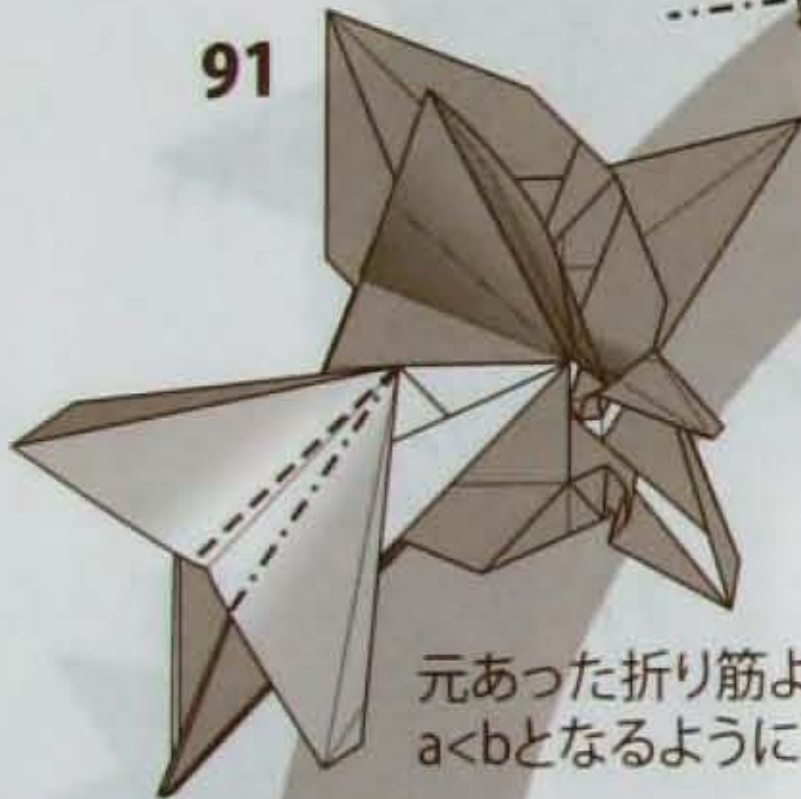

90

ずらすように折る

裏側はこの線で折られる

元あった折り筋より下側で山折り
a < b となるようにすること (91'参照)

91'

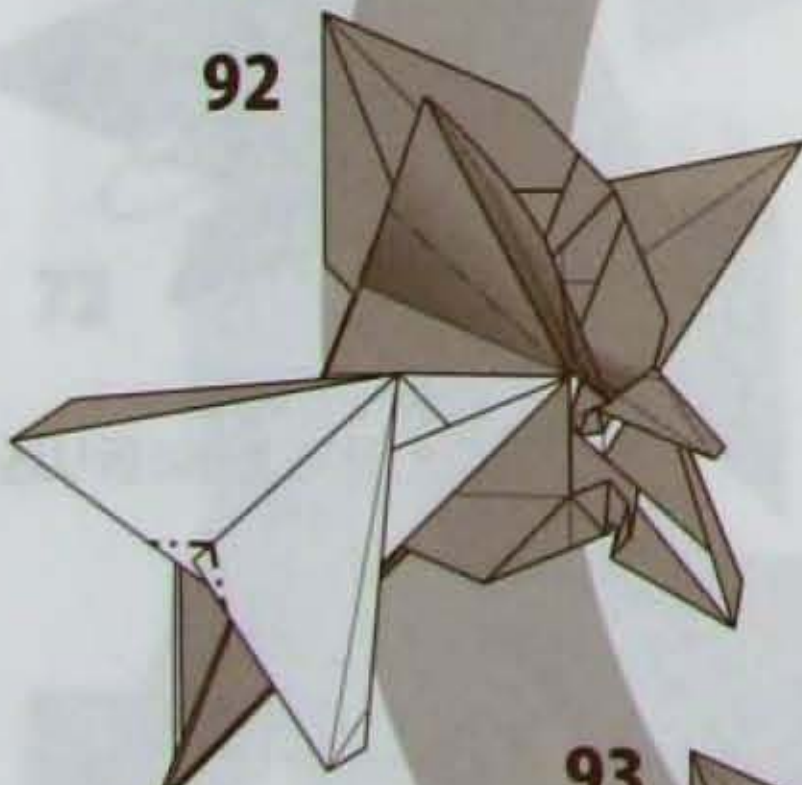
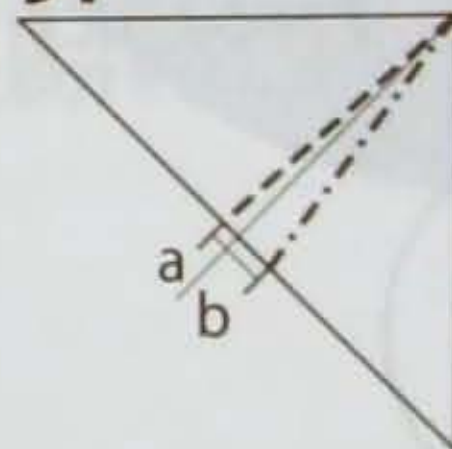

91

折り込んで凹みを作る
92'を参考にすること



92'

裏側から見た図



93

かぶせ折り

反対も87-94

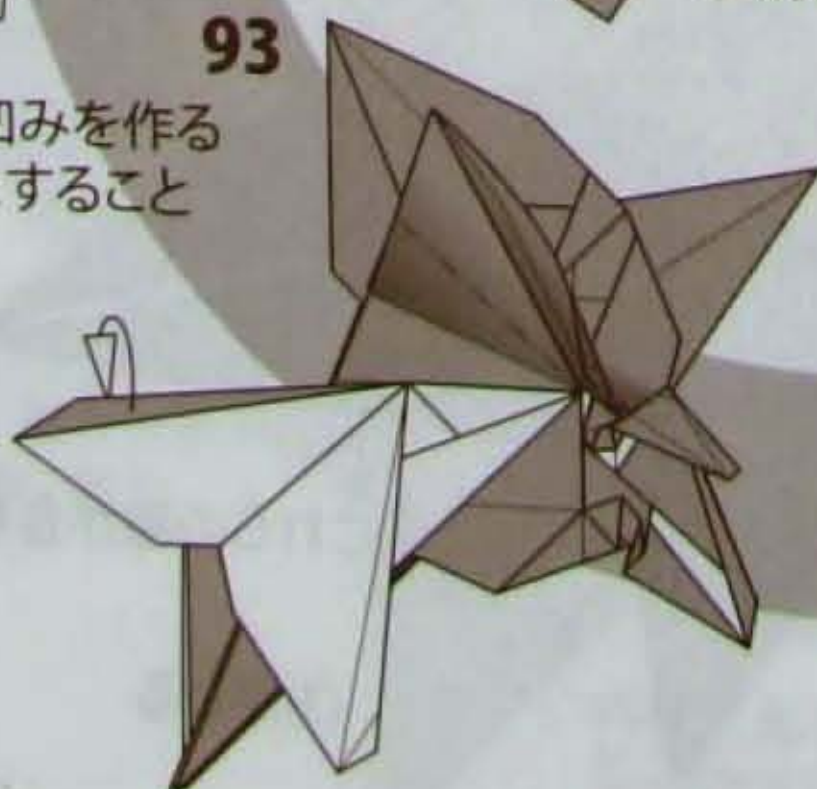

94

閉じる

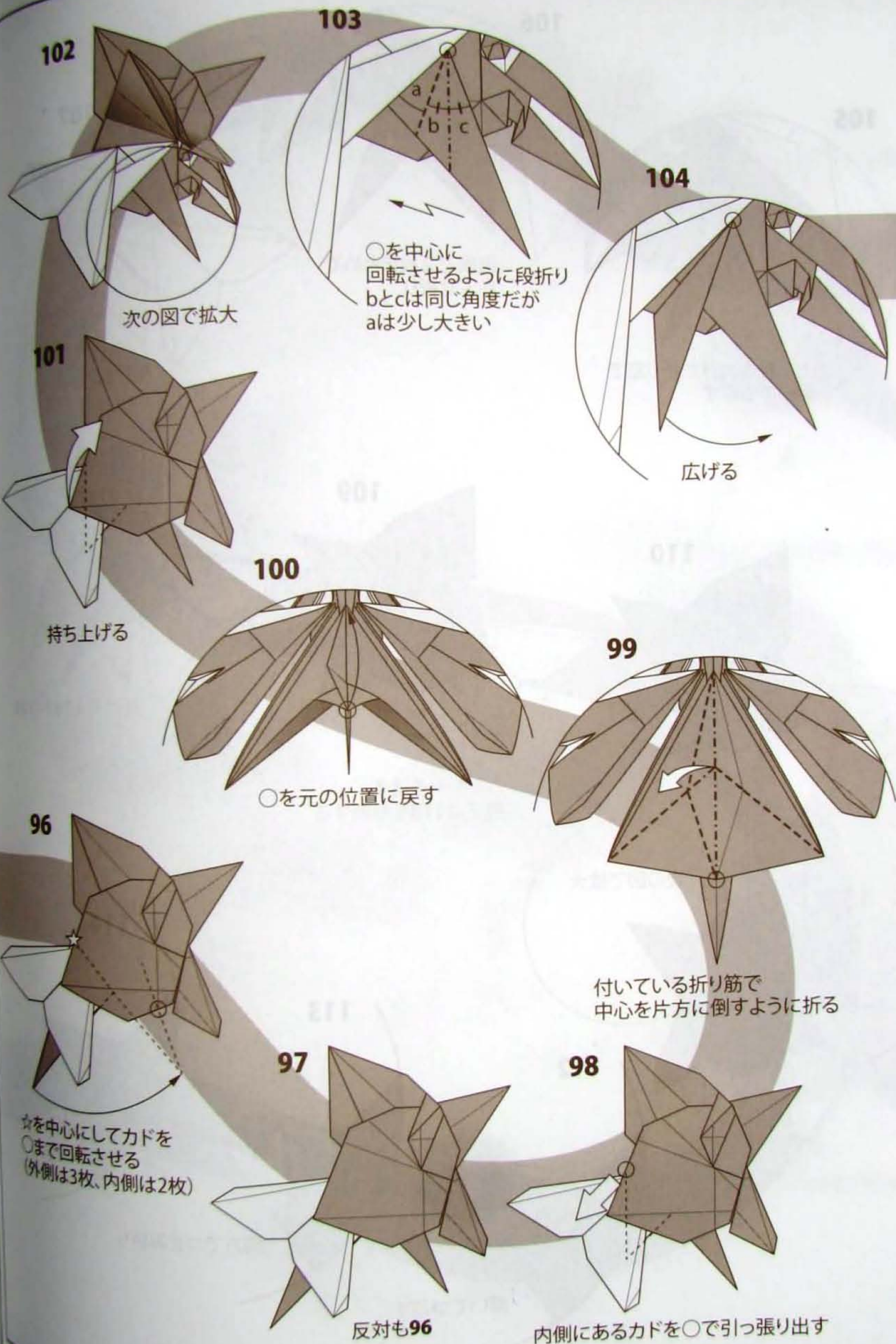

102

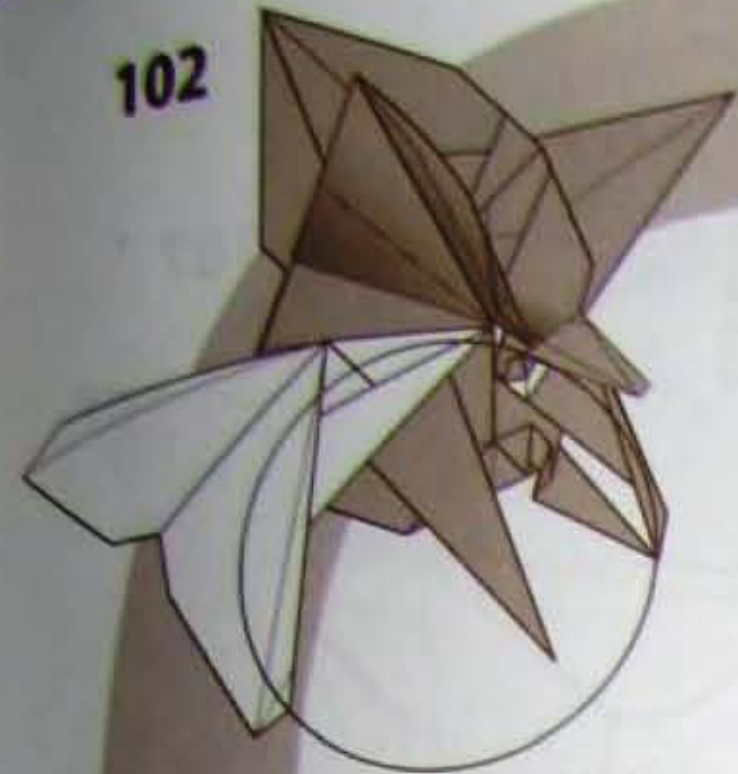

次の図で拡大

103



○を中心に
回転させるように段折り
bとcは同じ角度だが
aは少し大きい

104

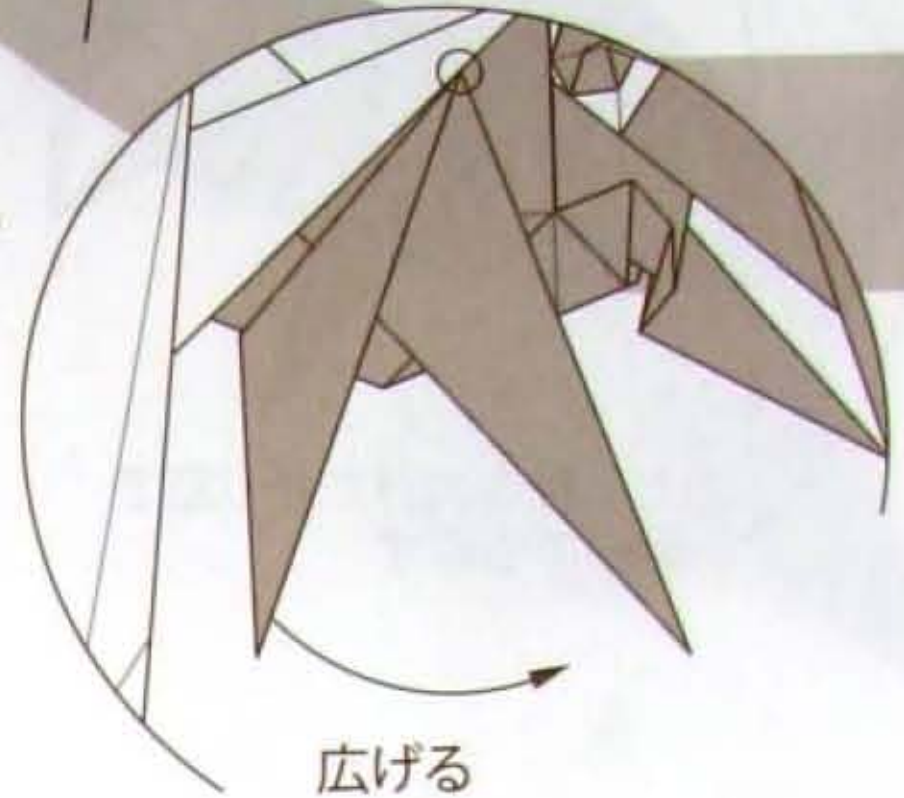

広げる

101

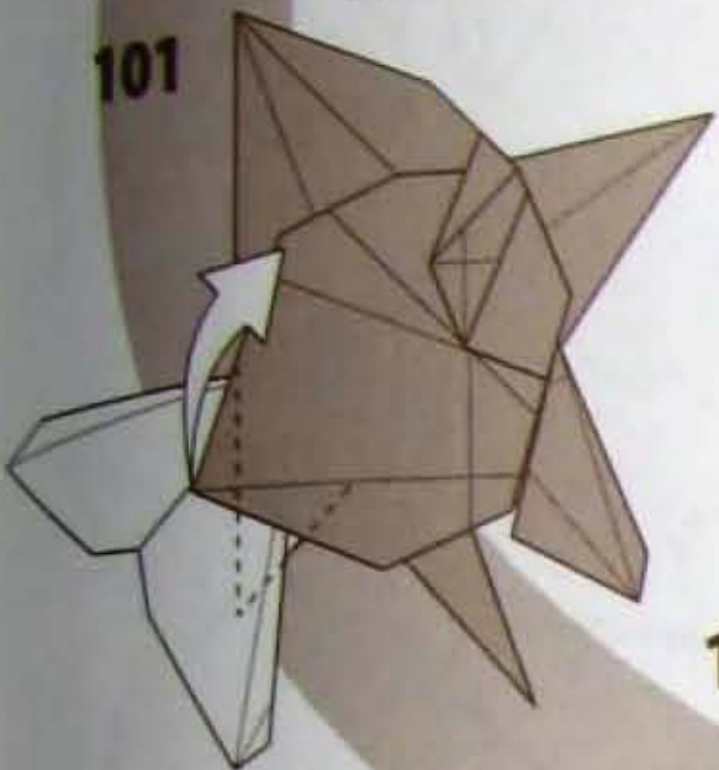

持ち上げる

100

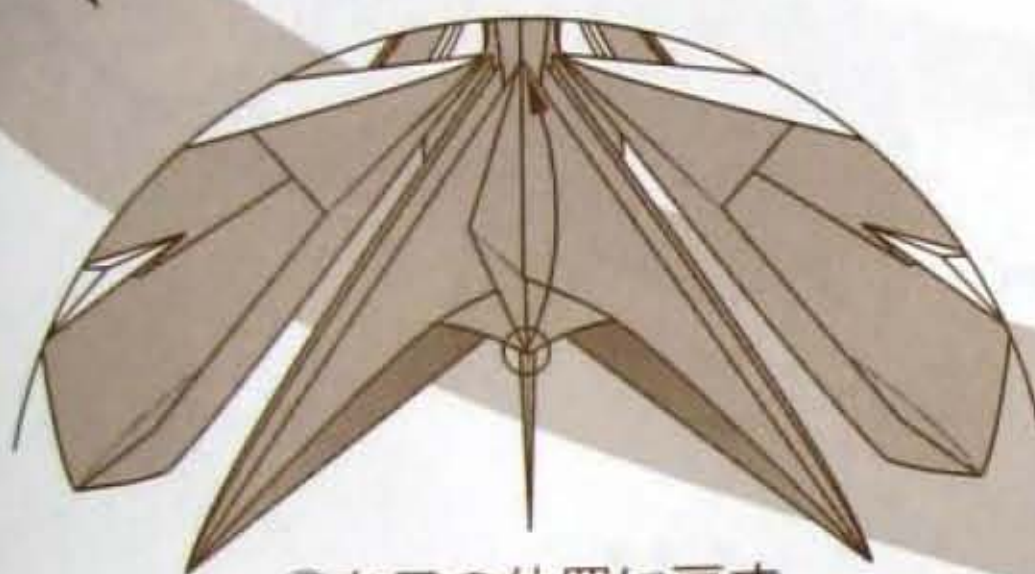

○を元の位置に戻す

99

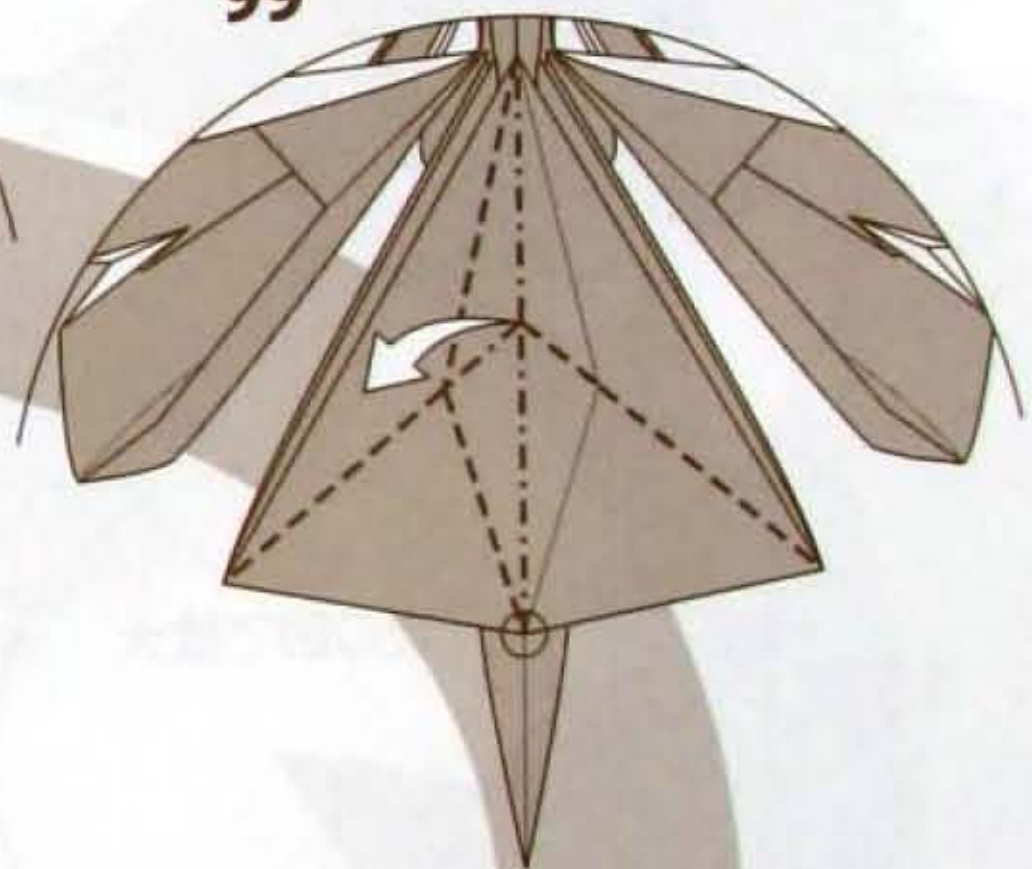

付いている折り筋で
中心を片方に倒すように折る

96

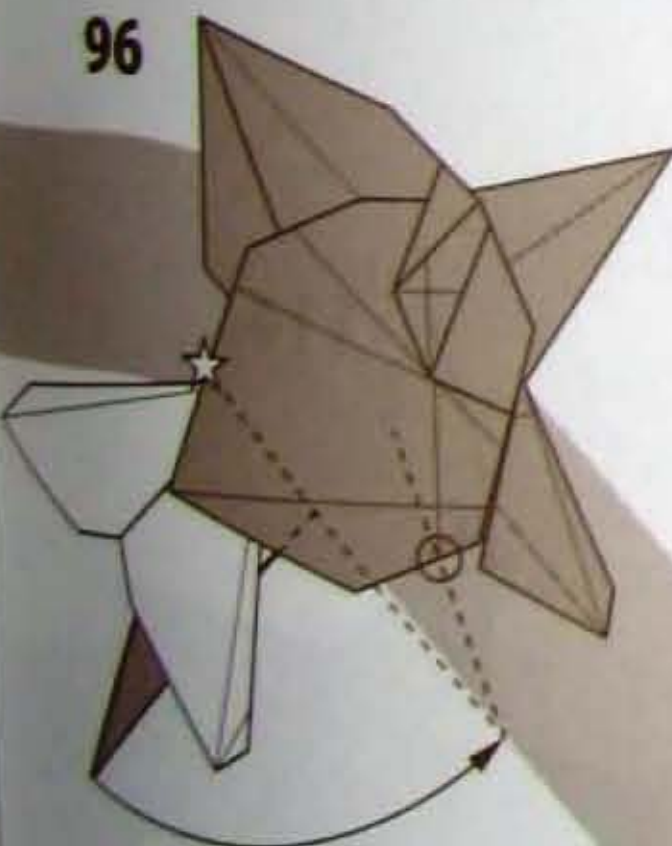

☆を中心にしてカドを
○まで回転させる
(外側は3枚、内側は2枚)

97

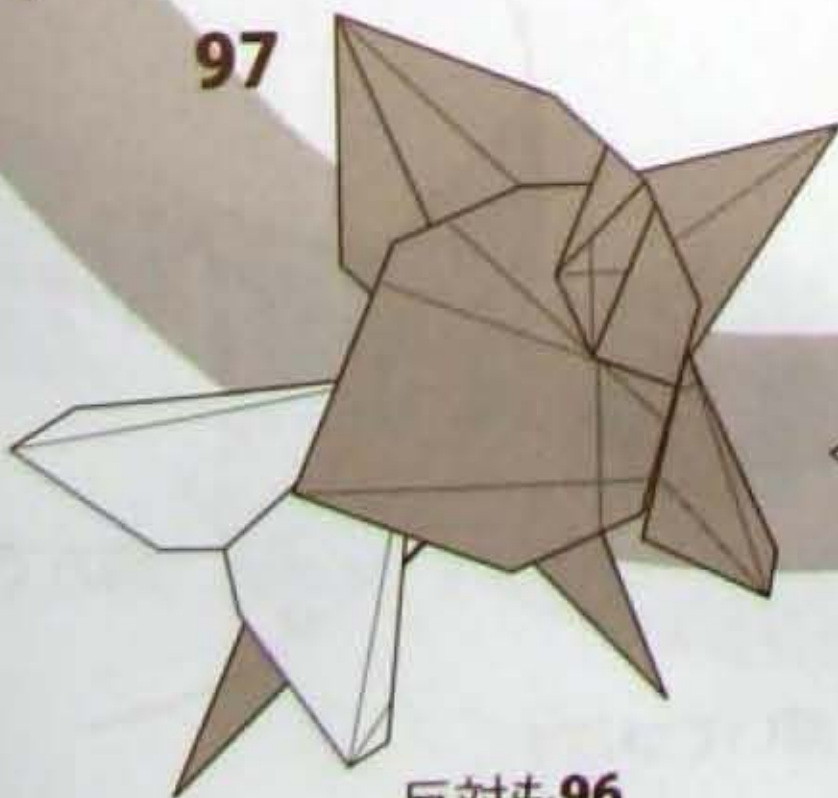

反対も96

98

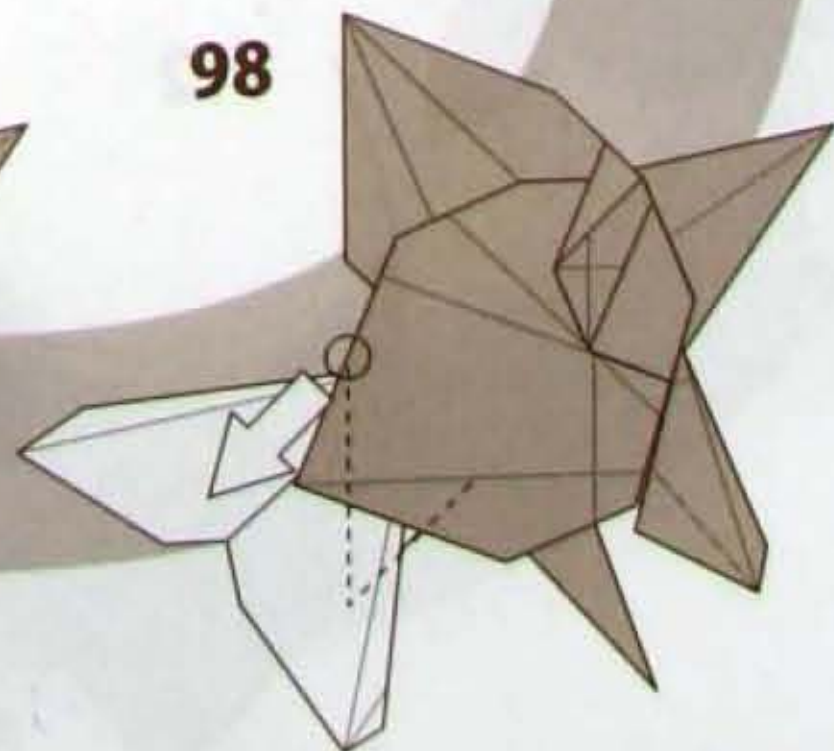

内側にあるカドを○で引っ張り出す

105

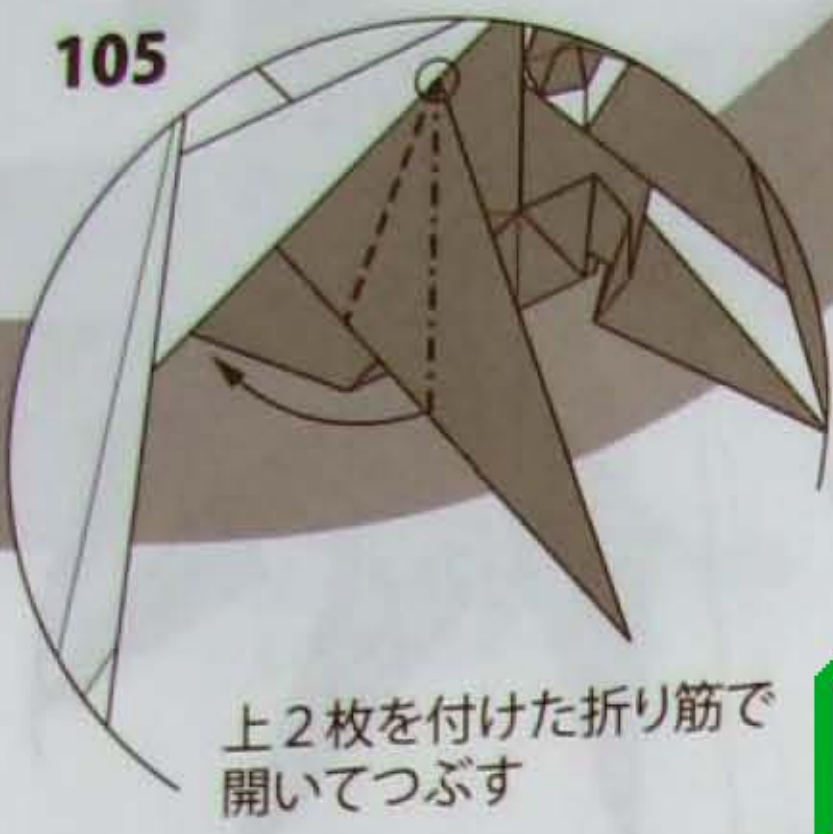

上2枚を付けた折り筋で開いてつぶす

106



両側で2枚まとめてかぶせ折り

107

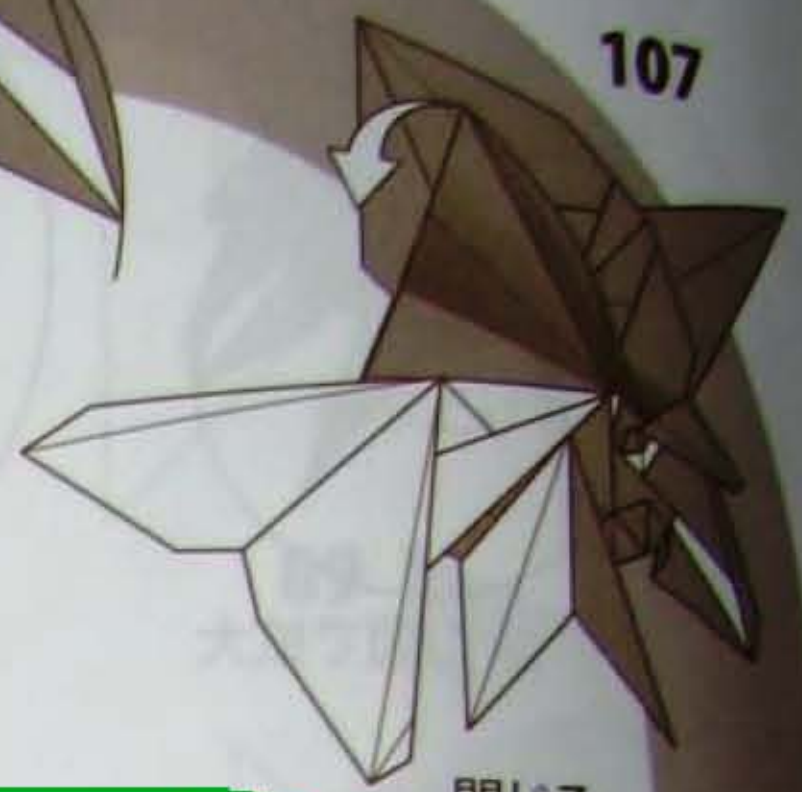

閉じる

Japão Burajirujin

www.japaoburajirujin.blogspot.com

108



反対側も101-109

109

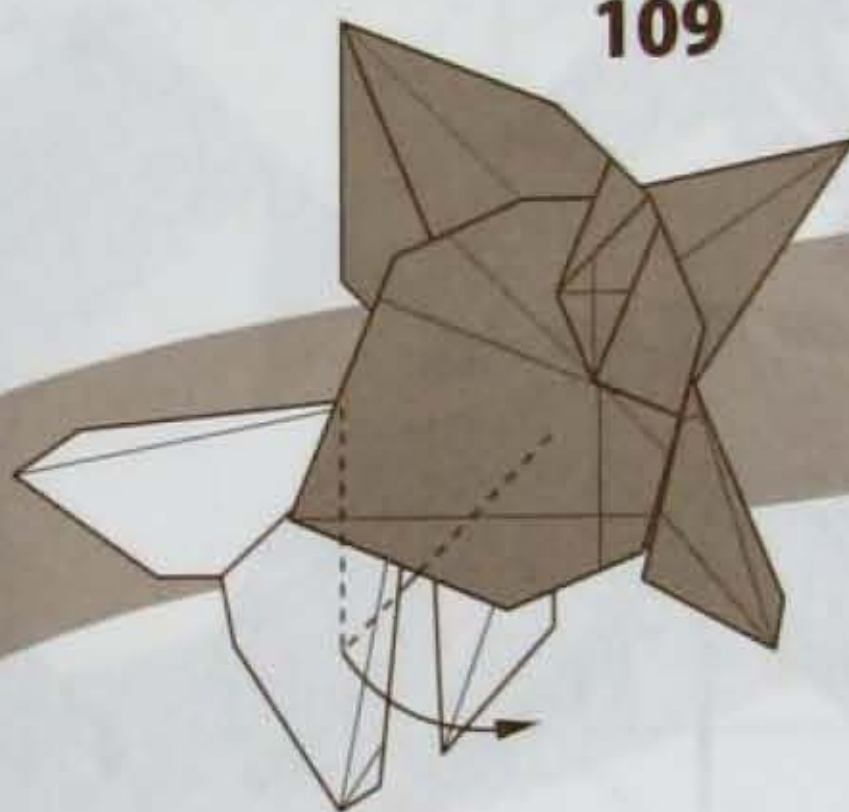

カドを引き出す程度は110を参照する

110

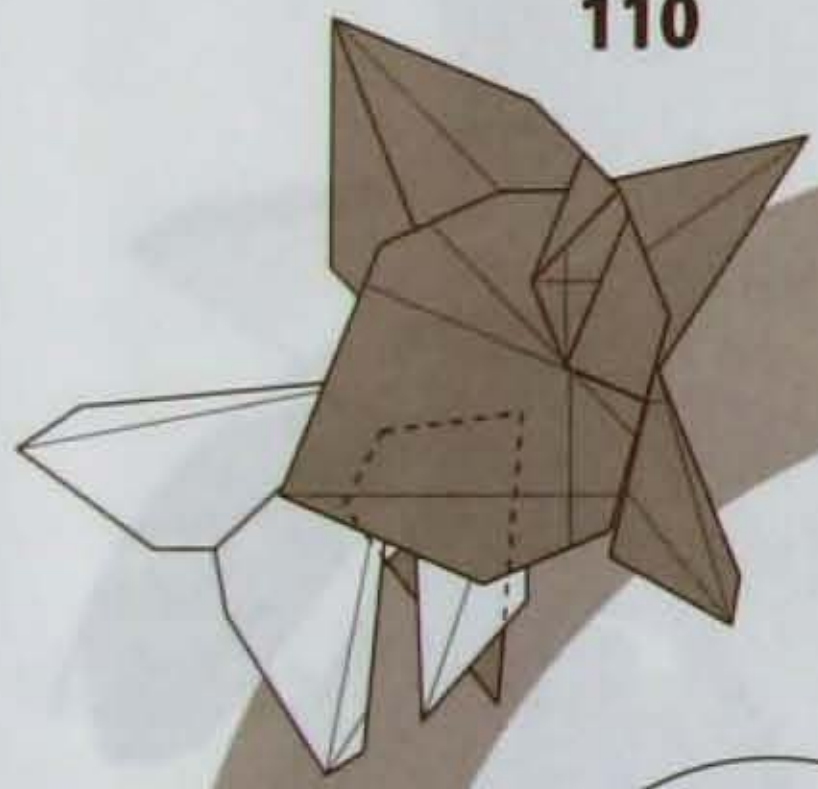

次の図で拡大

111

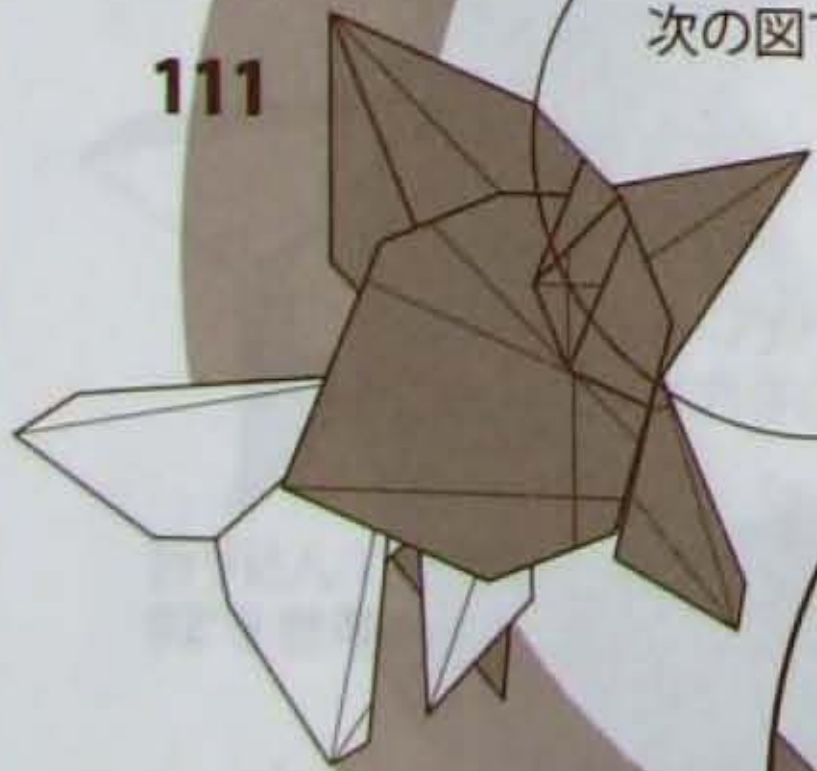

114

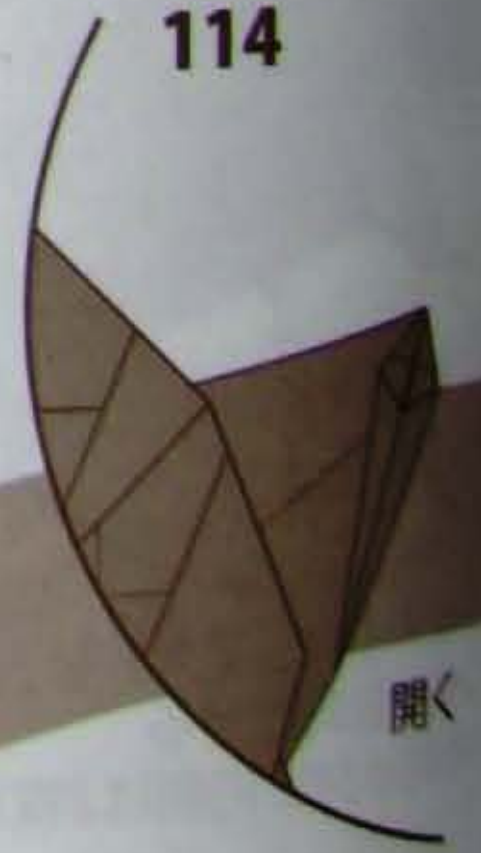

開く

113

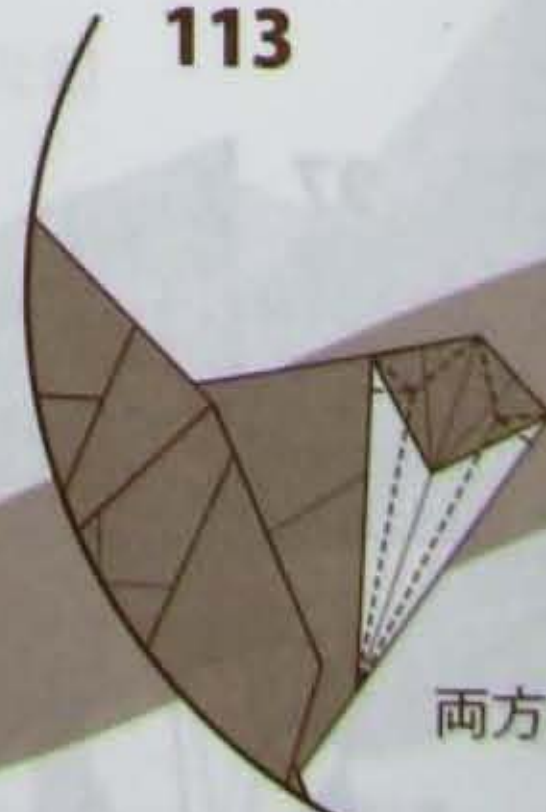

両方でつまみ折り

112

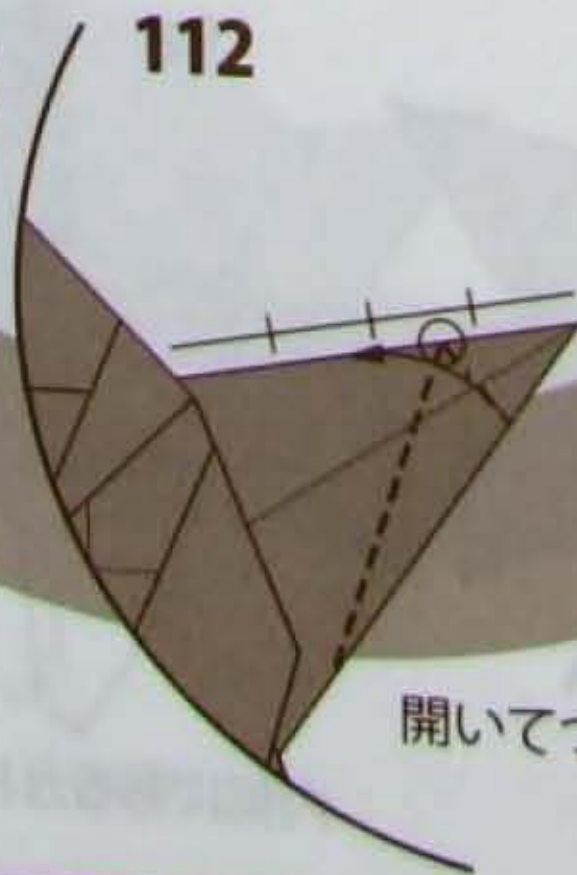

開いてつぶす

123



☆と○をつなぐ線で山折り
端は引き延ばすように平らにする

124

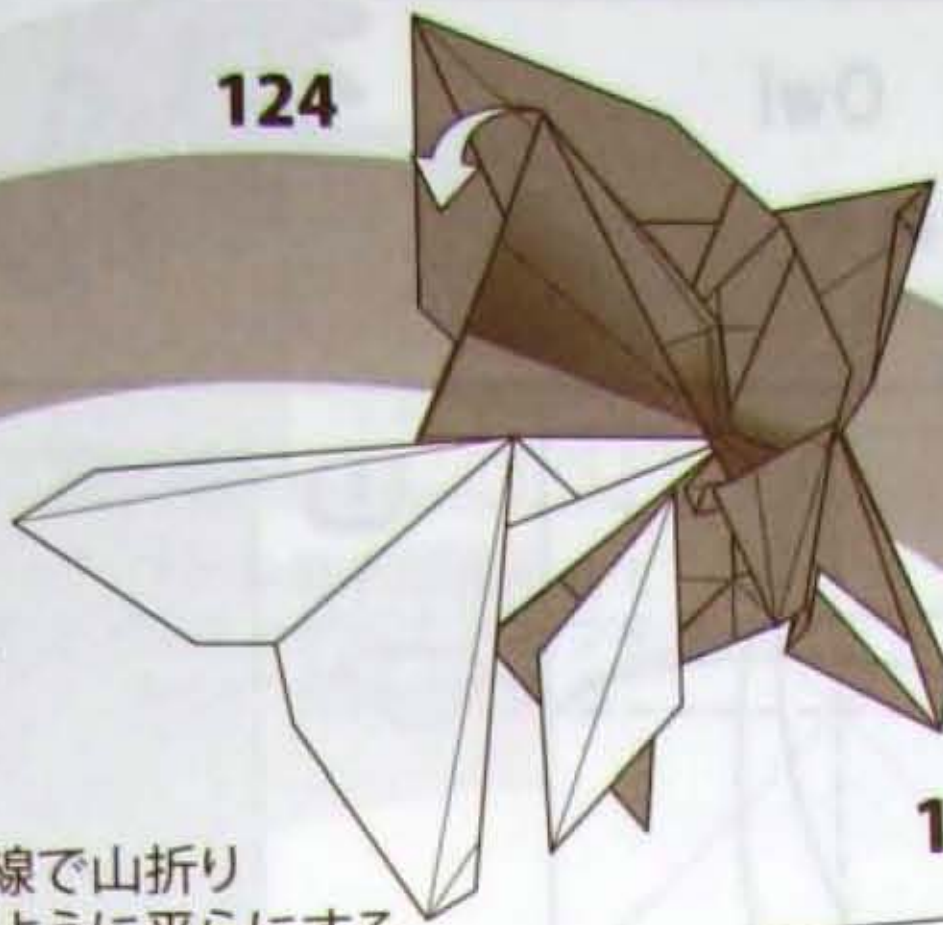

反対側も
118~124

畳まれている部分を
軽く開く

125



胴体を膨らませる
ヒレはカール、筋を付ける等を施しても良い

122



ヒレと胴体との交差点に注目(○印)
持ち上げる

119

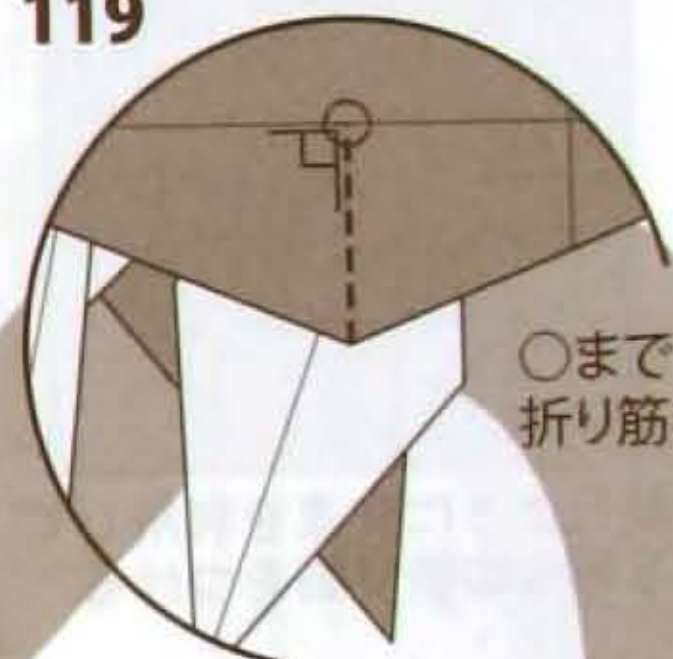

○まで
折り筋を付ける

121



出来た内側のカドを
折り込んで止め折り

120

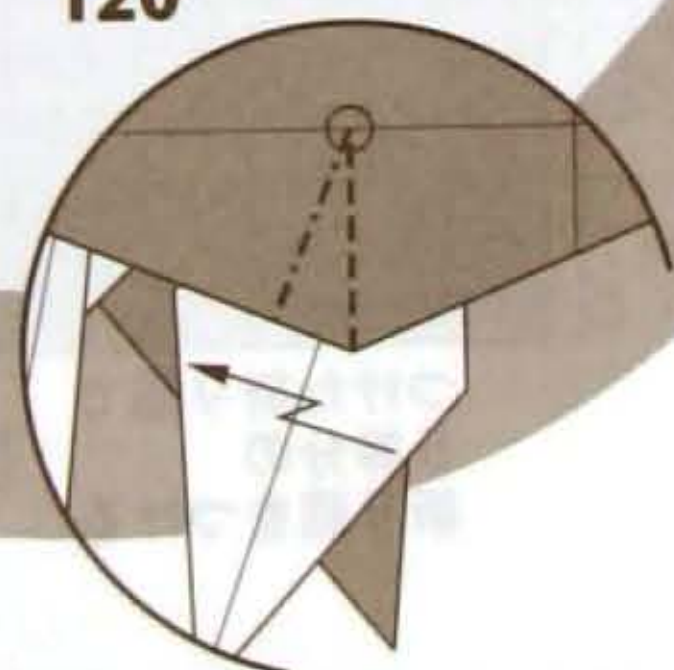

○を中心に回転させるように
段折りして立体化

118

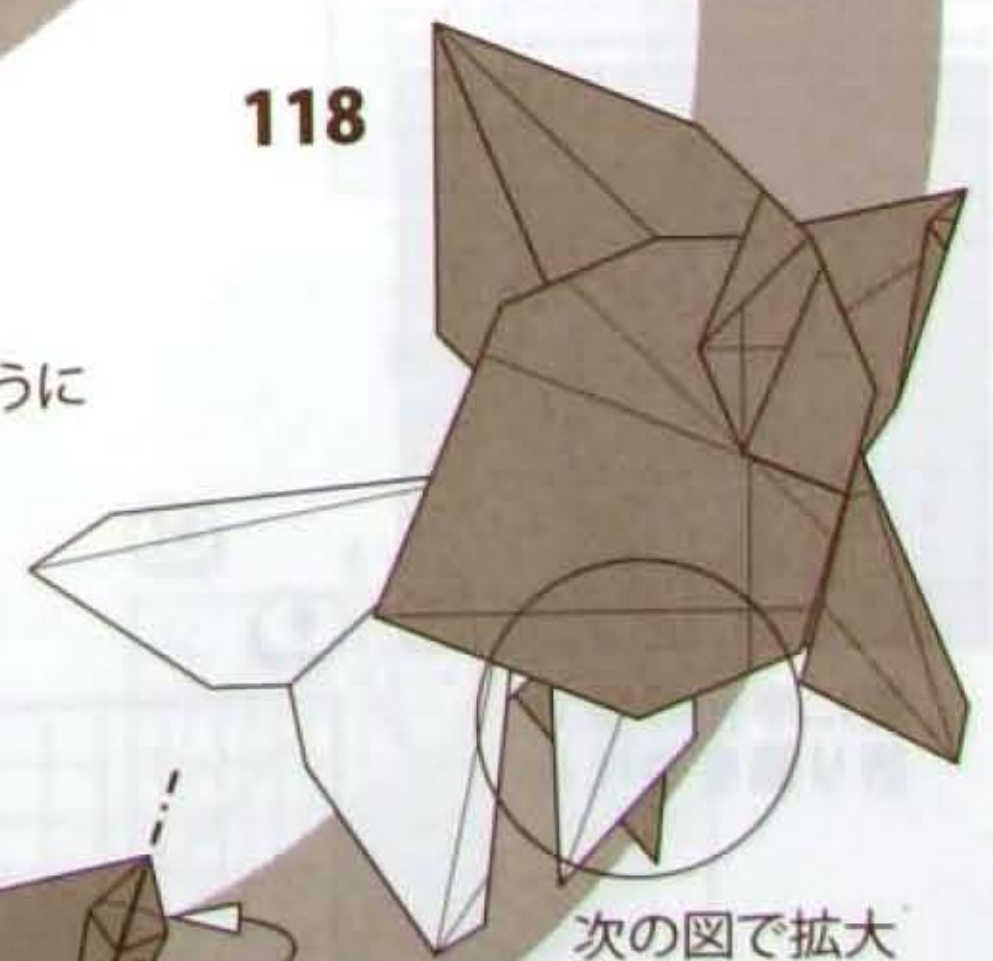

次の図で拡大

115



折り込む

116

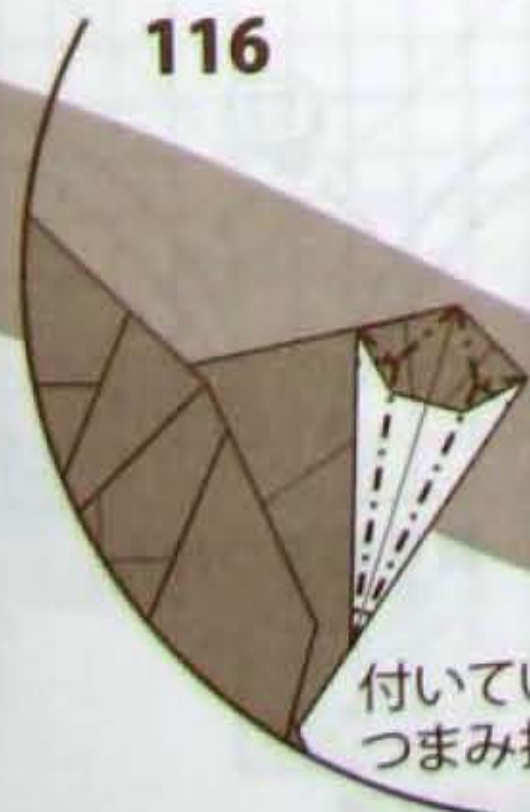

付いている折り筋で
つまみ折り

117

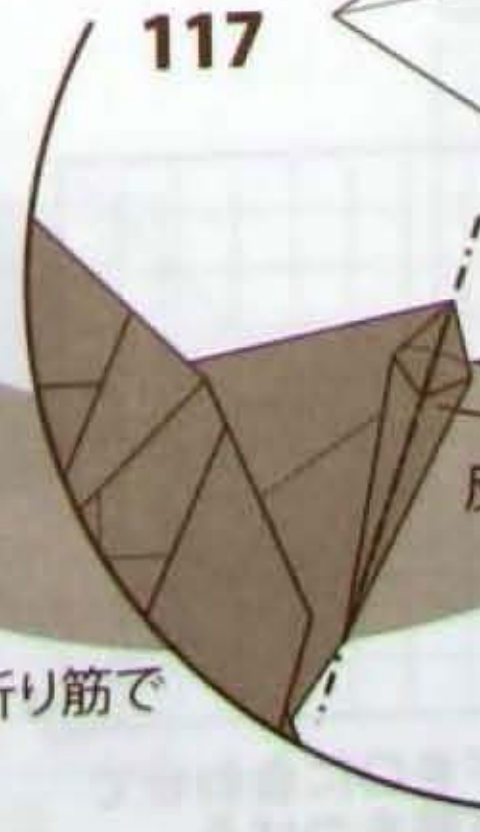

反対側に折る

109

開く

フクロウ Owl

作・図：勝田恭平
by Kyohei Katsuta

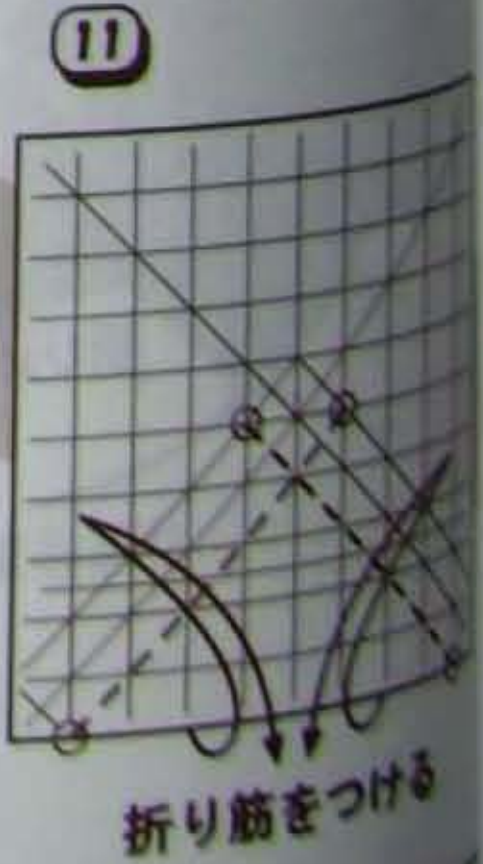
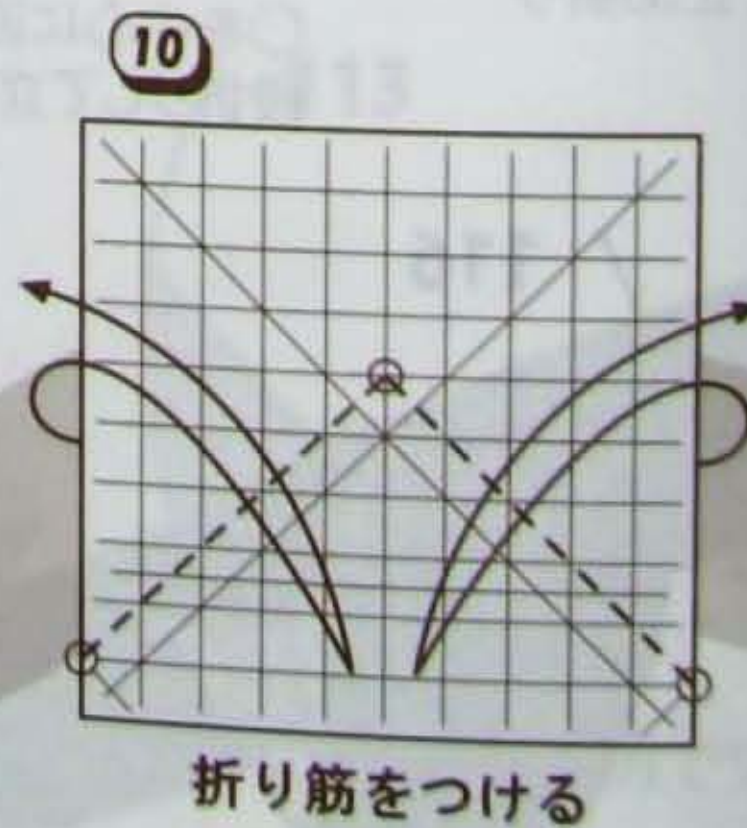
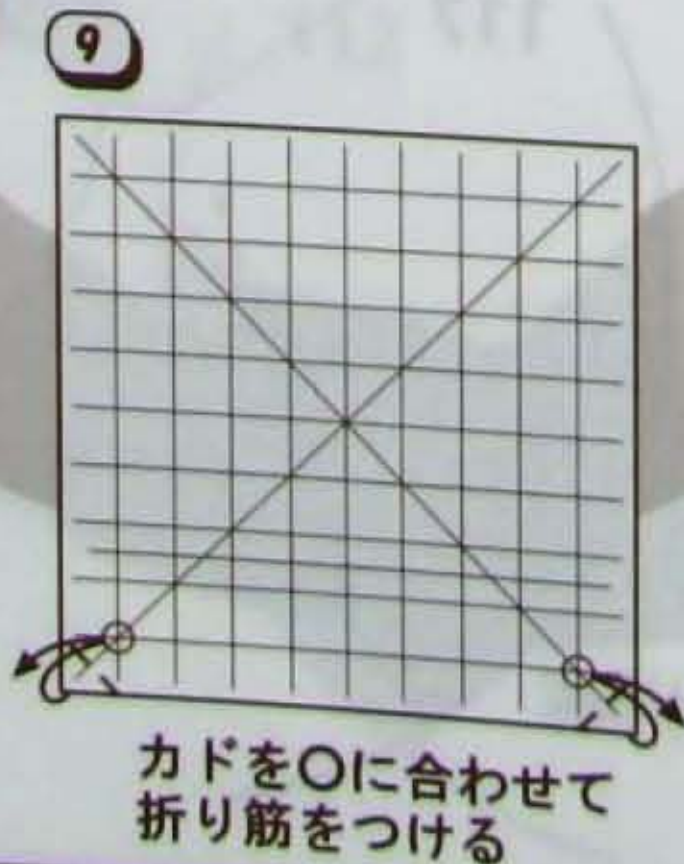
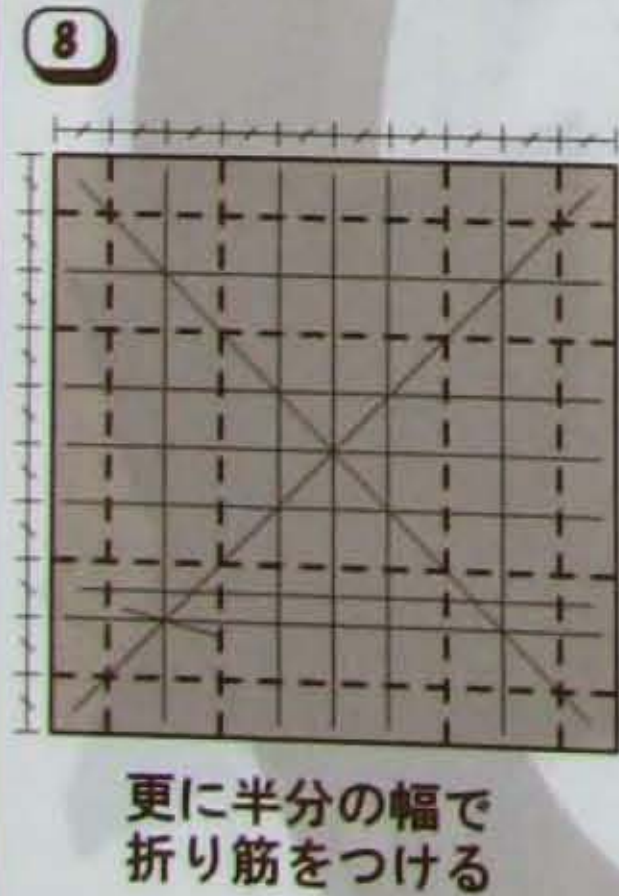
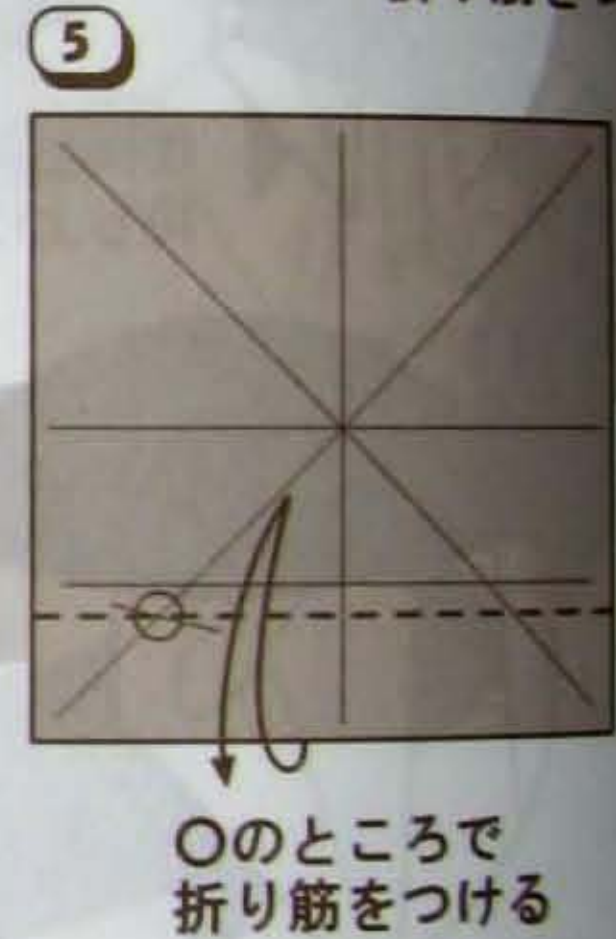
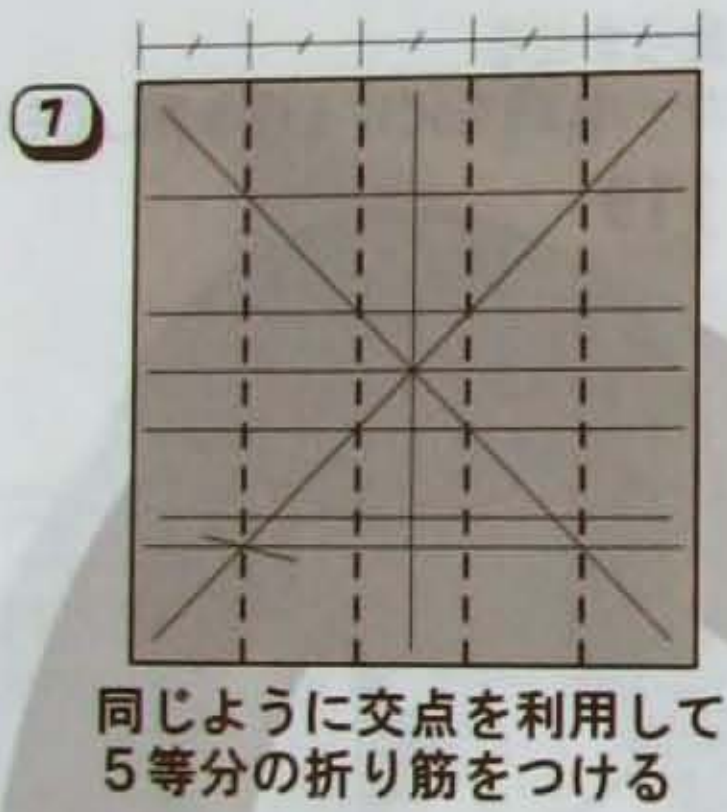
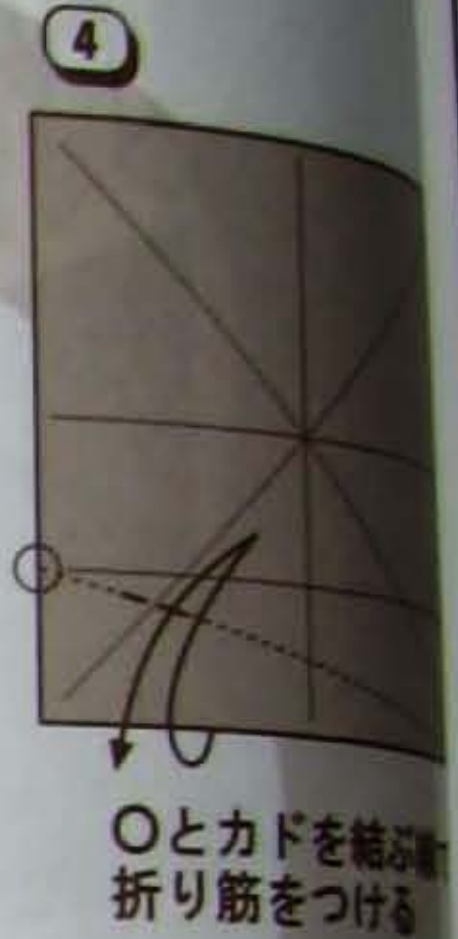
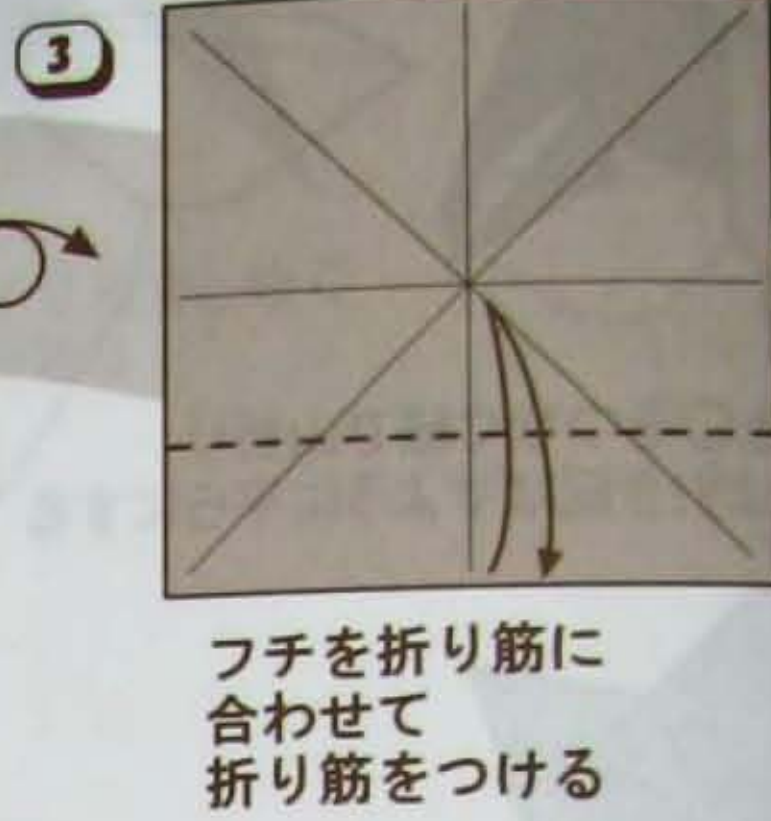
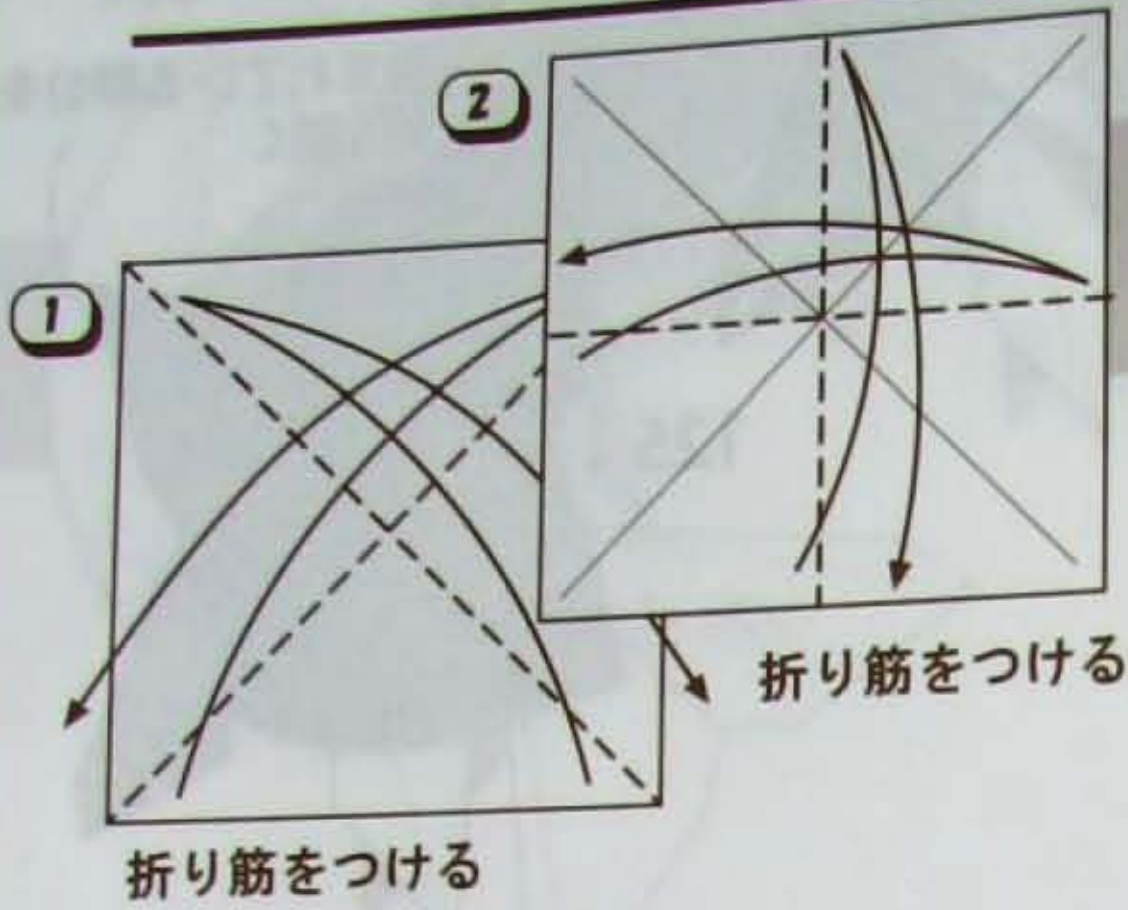

19

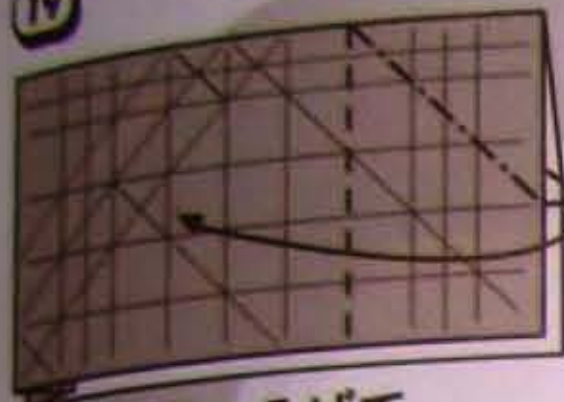

内側をひろげて
つぶすように折る

90°

18

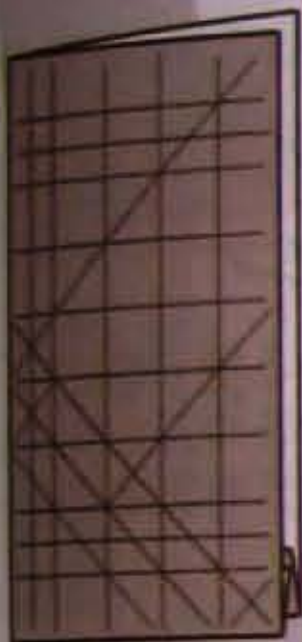

20

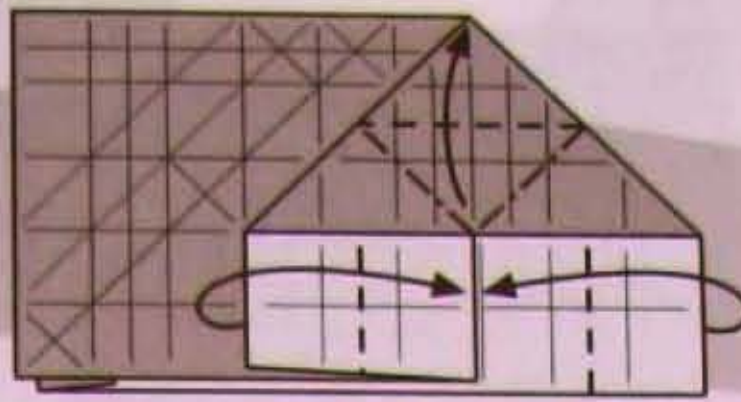

フチをカドに合わせて
起き上がってきたフチを
中心に合わせて折る

21

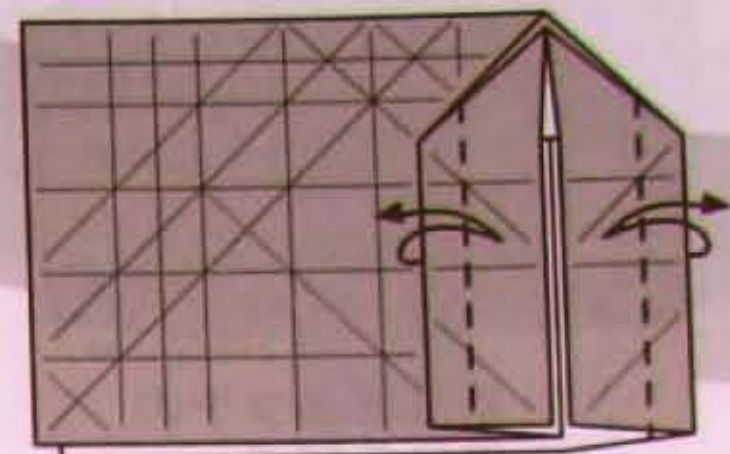

フチをついている
折り筋で折って
折り筋を付け直す

Japão Burajirujin

www.japaoburajirujin.blogspot.com

16

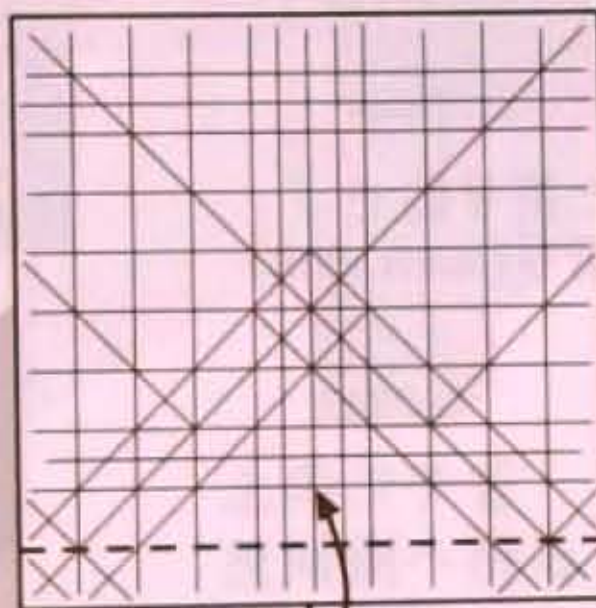

フチをついている
折り筋で折る

15

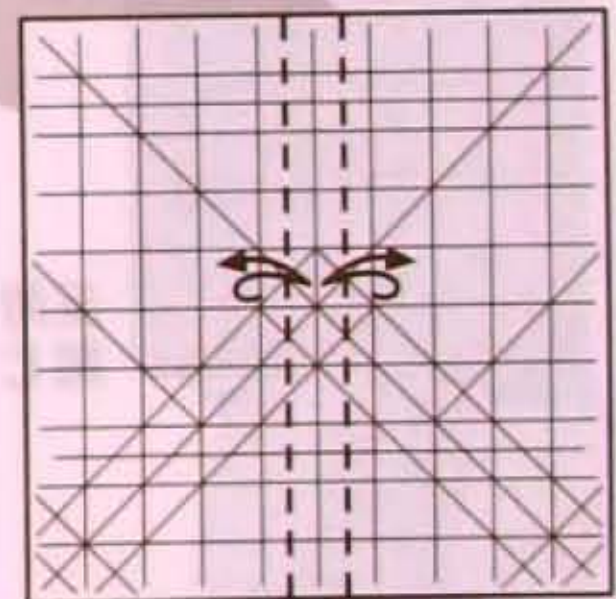

ついている折り筋を
つまんで半分の幅で
折り筋をつける

17

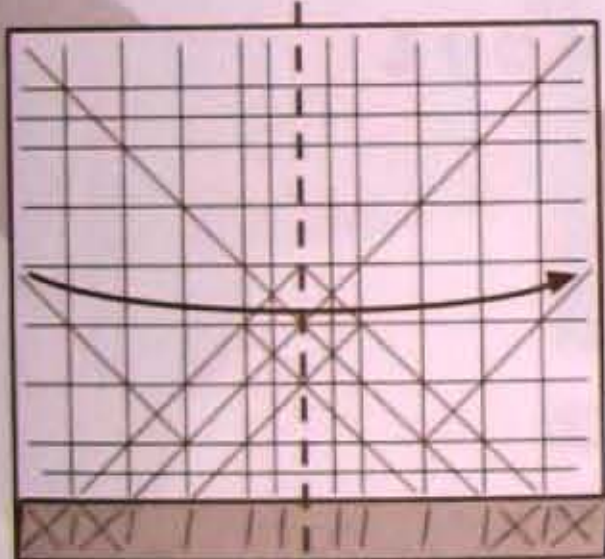

半分に折る

14

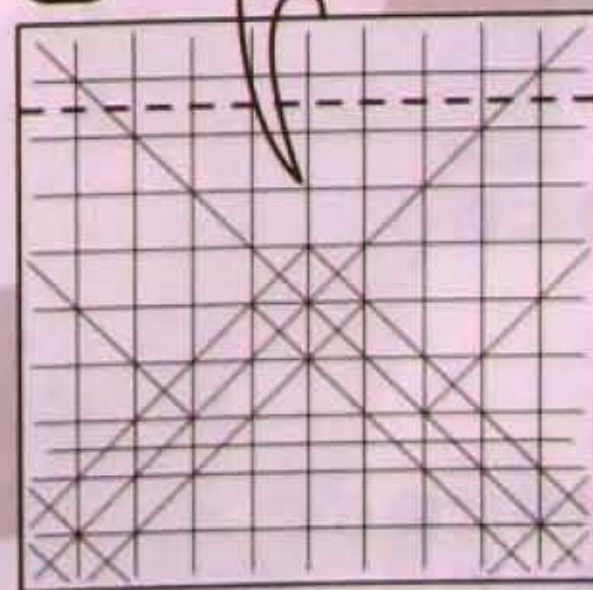

フチを折り筋に
合わせて
折り筋をつける

13

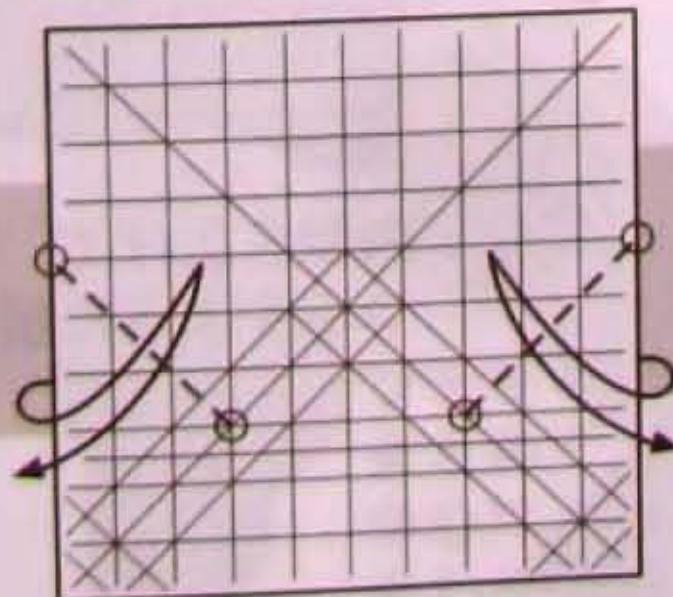

折り筋をつける

12

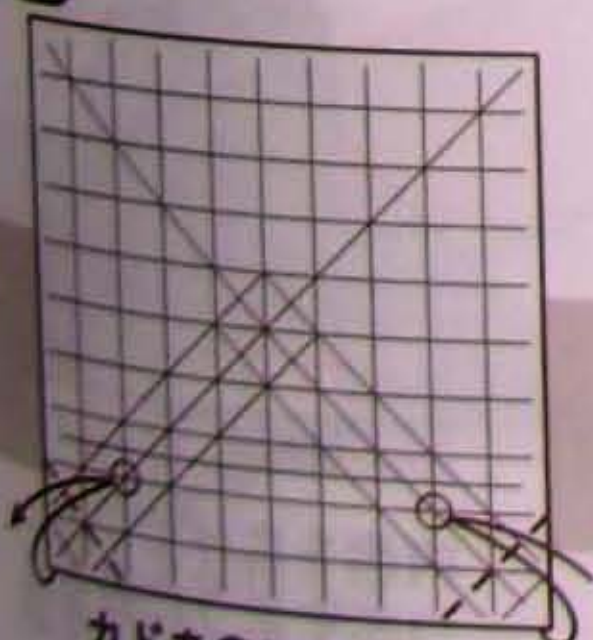

カドをOに合わせて
折り筋をつける

22

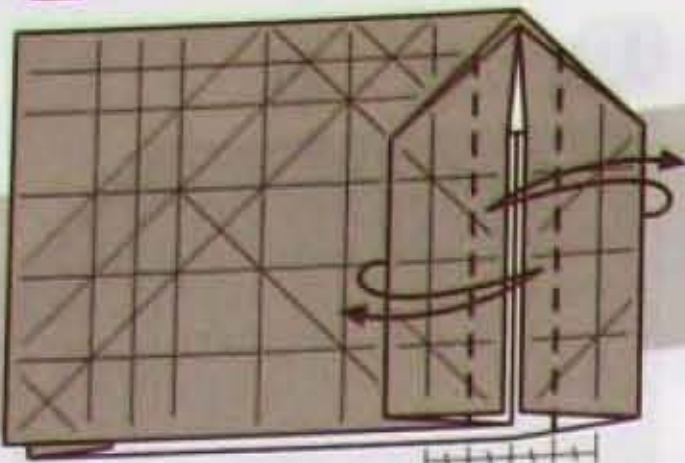

折り筋とフチの
半分の幅で
折り筋をつける

23

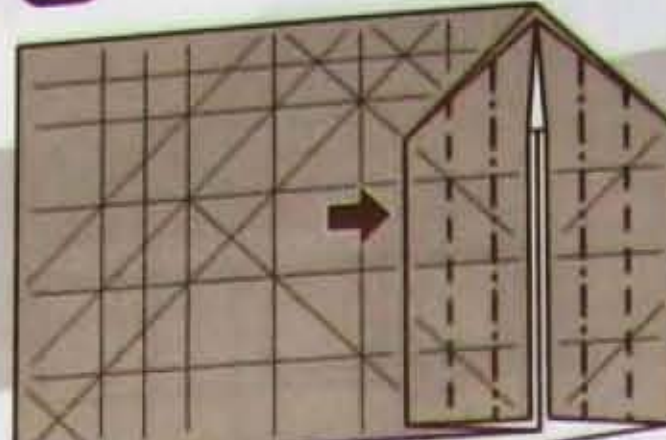

つけた折り筋で
沈め段折り
(open sink)

24

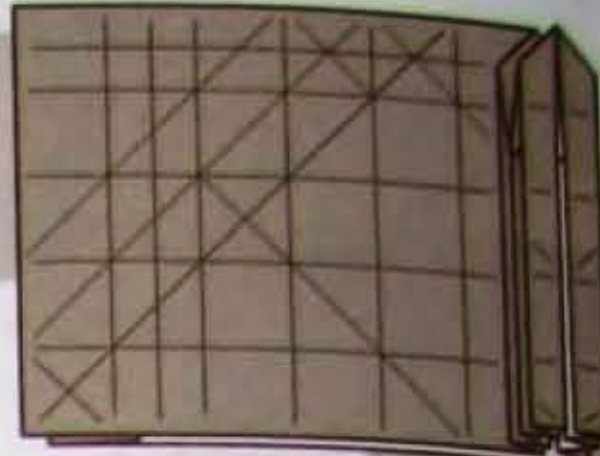

27

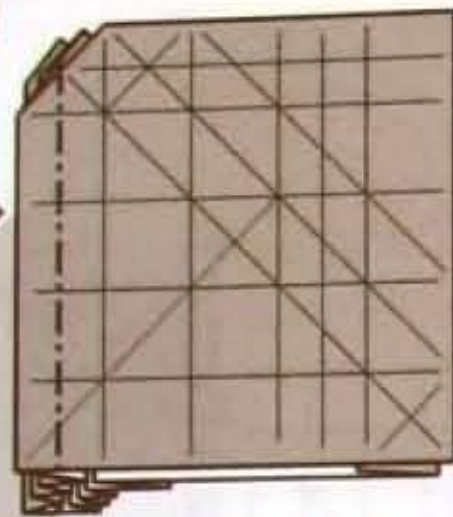

つけた折り筋で
沈め折り(open sink)

26

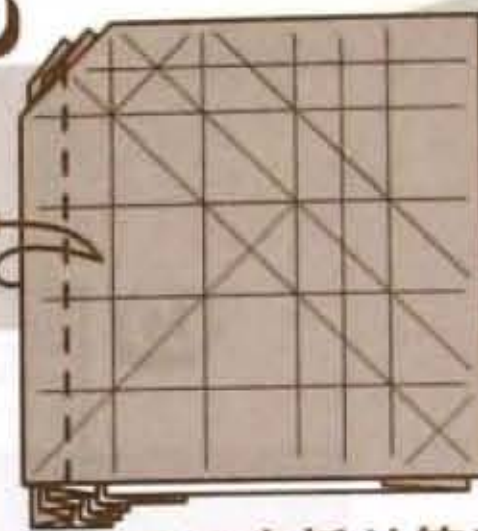

フチを折り筋に
合わせて
折り筋をつける

25

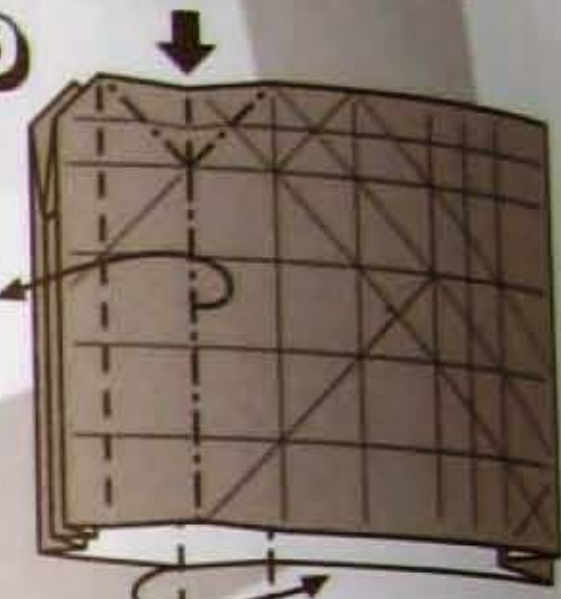

ついている折り筋で
上の部分をつぶしながら
できたヒダを左右に折る

28

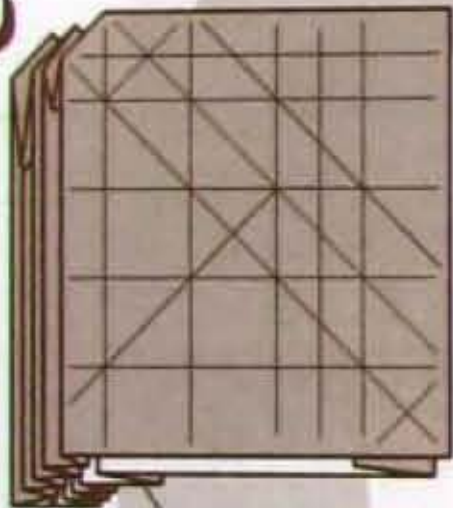

反対側も
同じように折る

26-27

29

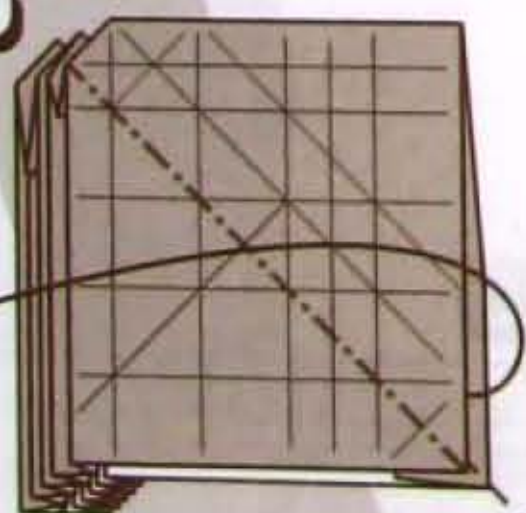

内側を
広げて
つぶすように折る

31

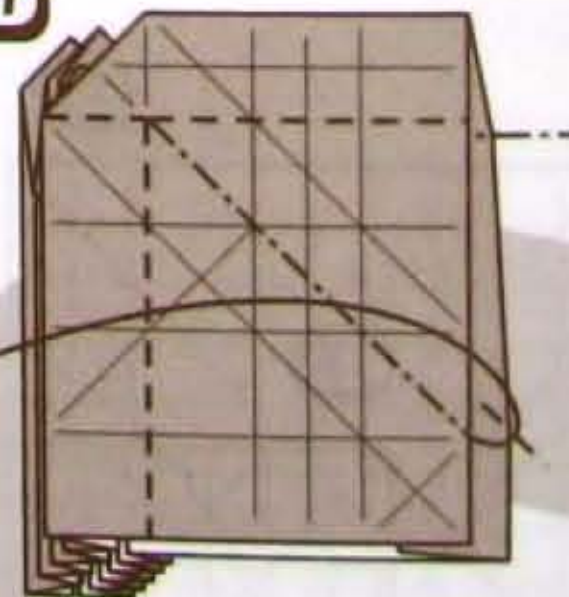

内側を広げて
つぶすように折る

32

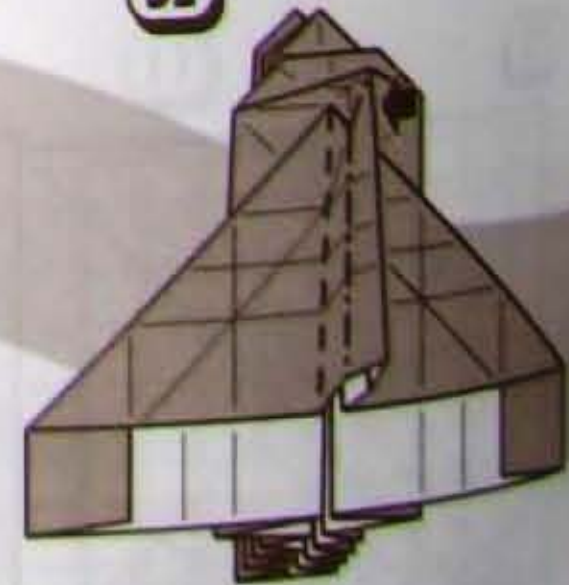

内側を広げて
つぶすように折る

30

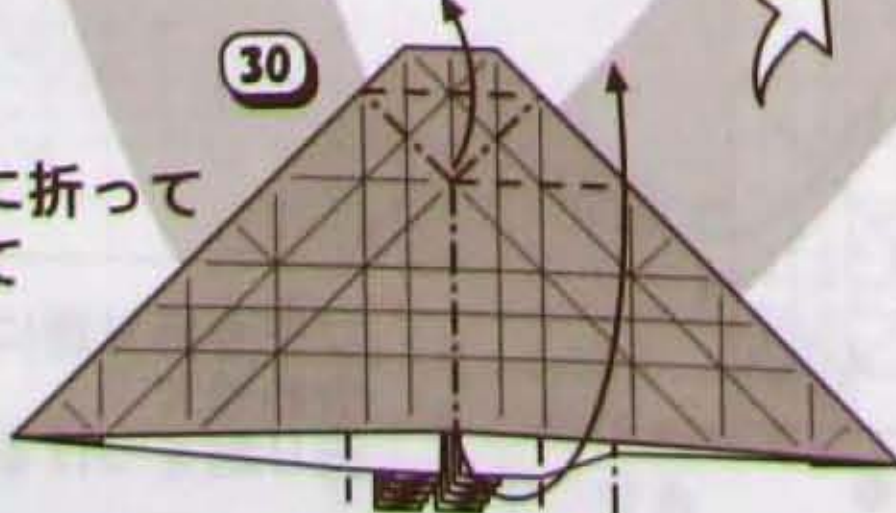

フチを半分に折って
起き上がって
きた部分を
折りたたむ

42



広がった
反対側

41



広がった部分
反対側へ折る

折り
位置
中心
つぶ

33



フチを上
起き上が
部分を折

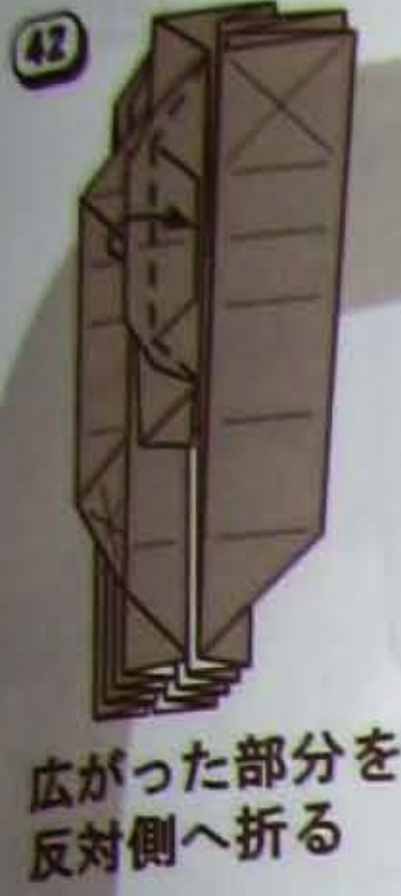

42 広がった部分を反対側へ折る

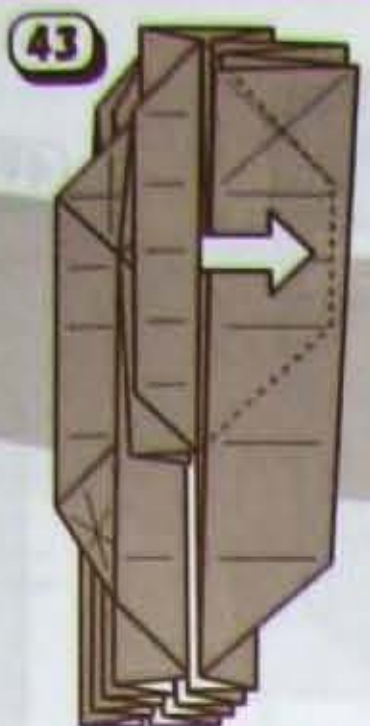

43 内側の紙を引き出す

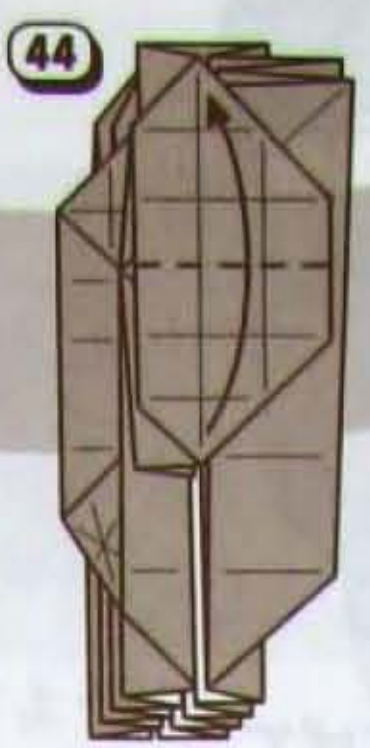

44 カドを上へ折る

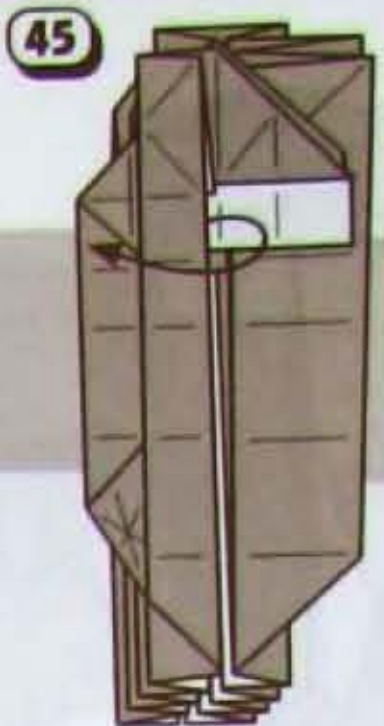

45 フチを軽く広げる



41 広がった部分を反対側へ折る

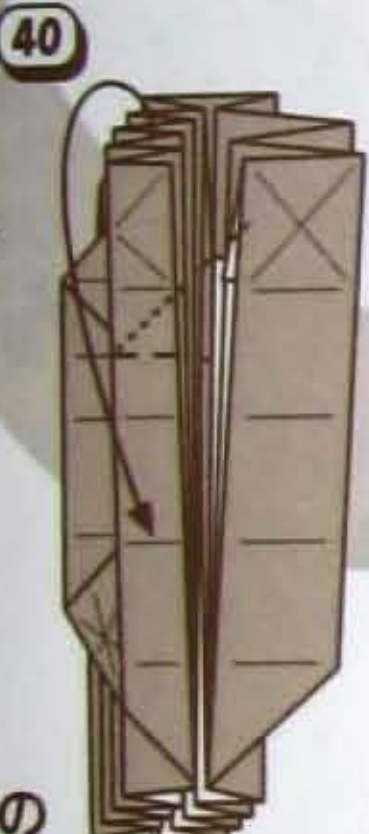

40 折り筋の位置で下へ折って中心の部分を広げてつぶすように折る

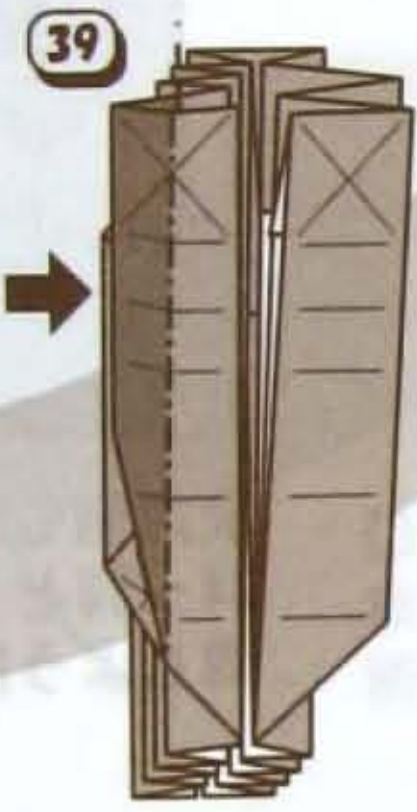

39 沈め折り (closed sink)

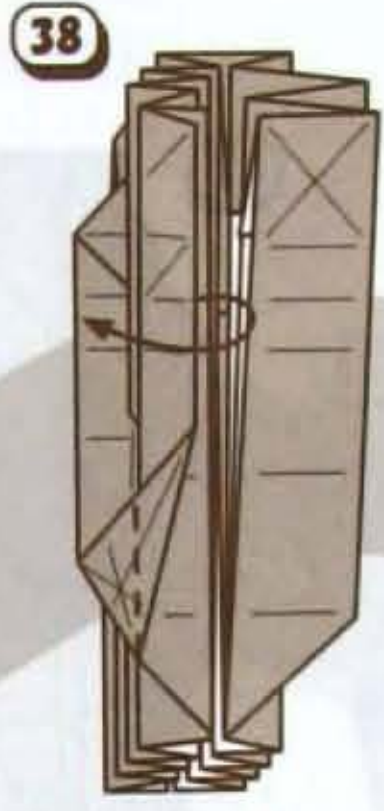

38 上のフチを反対側へ折る

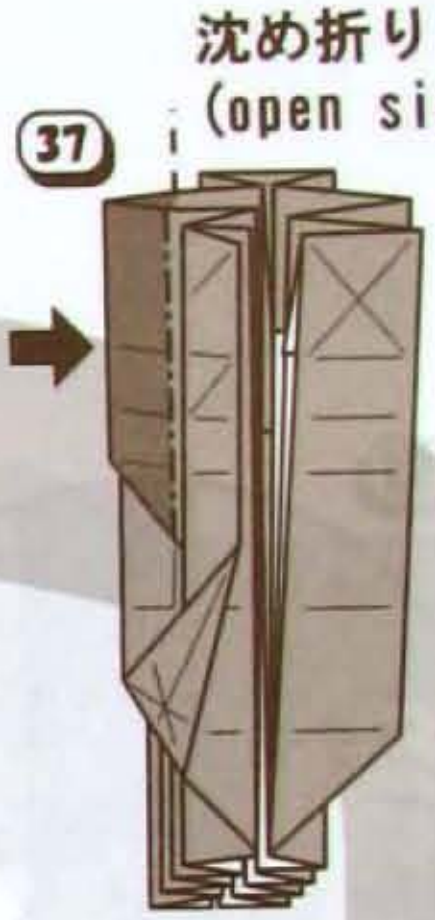

37 沈め折り (open sink)

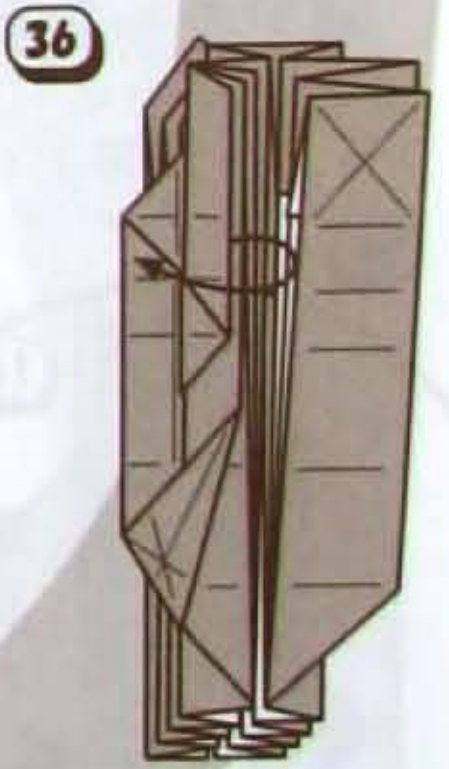

36 上のフチを反対側へ折る

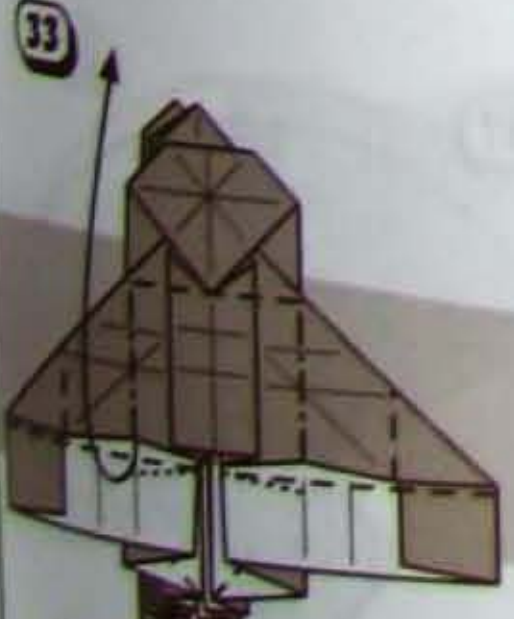

33 フチを上へ折って起き上がってきた部分を折り畳む

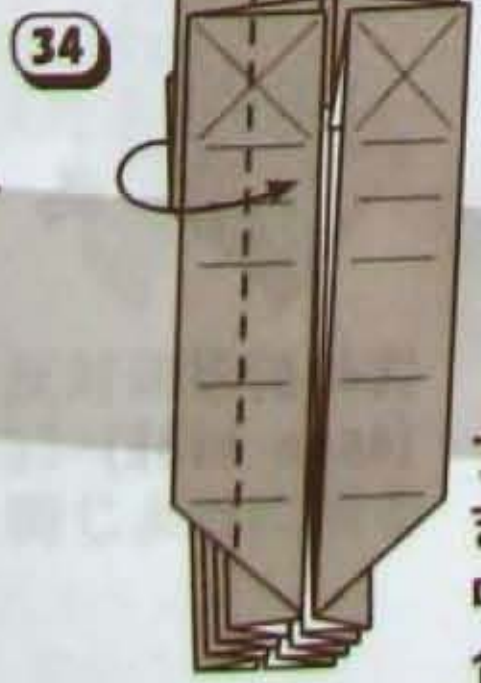

34 フチをまとめて中心に合わせて折る

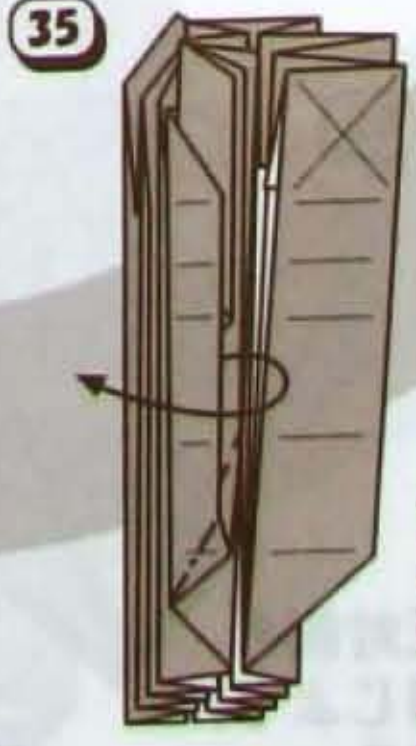

35 上のフチを反対側へ折りながら広げてつぶす様に折る

がら折る

に折る

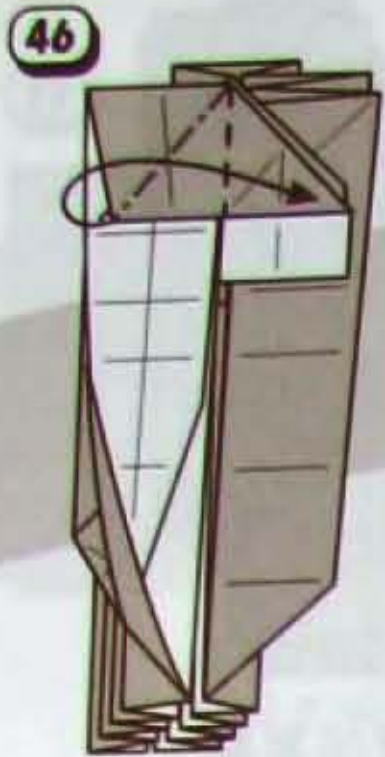

46 内側を広げて つぶすように折る

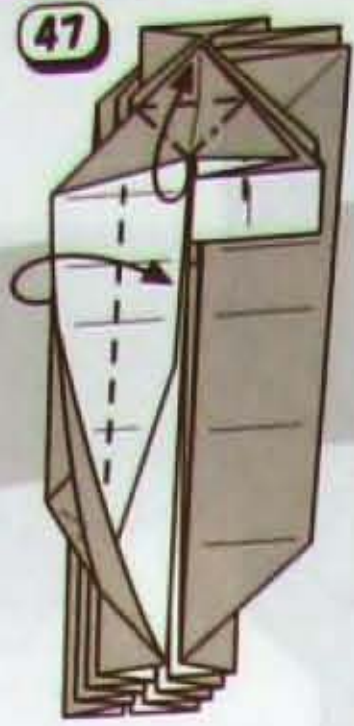

47 内側を広げて つぶしながら ひきよせる 様に折る

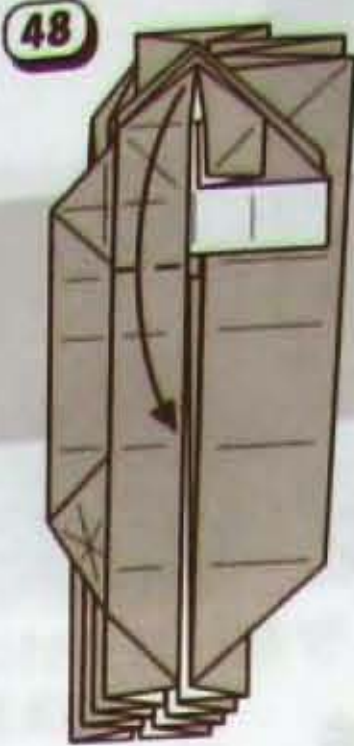

48 カドを下へ折る

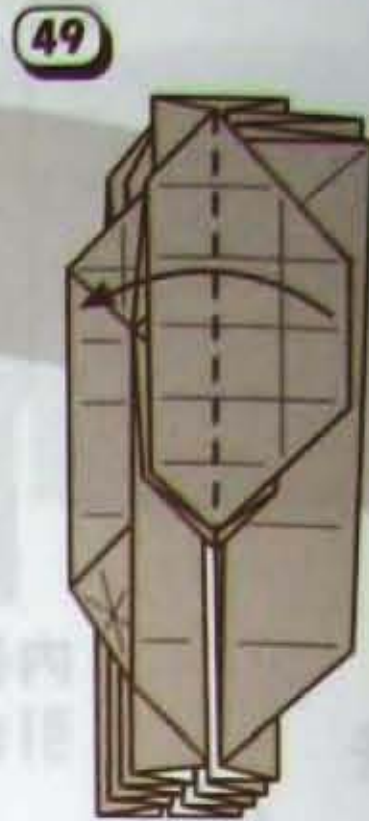

49 反対側へ 折る

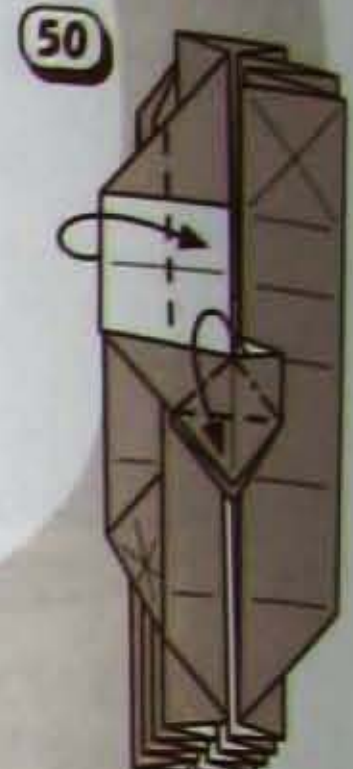

50 内側を広げて つぶしながら ひきよせる ように折る

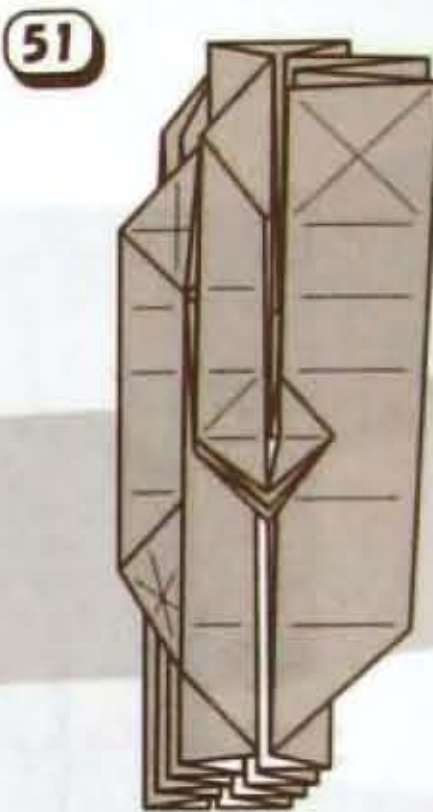

51 反対側も 34~50と 同じように折る

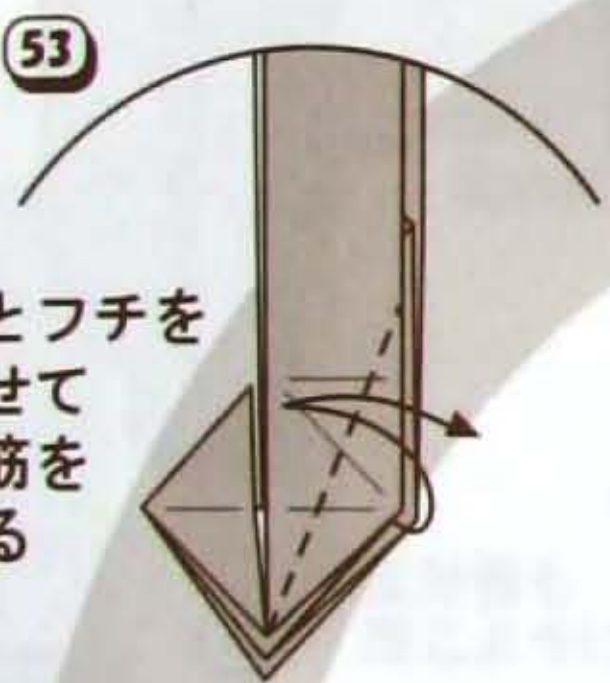
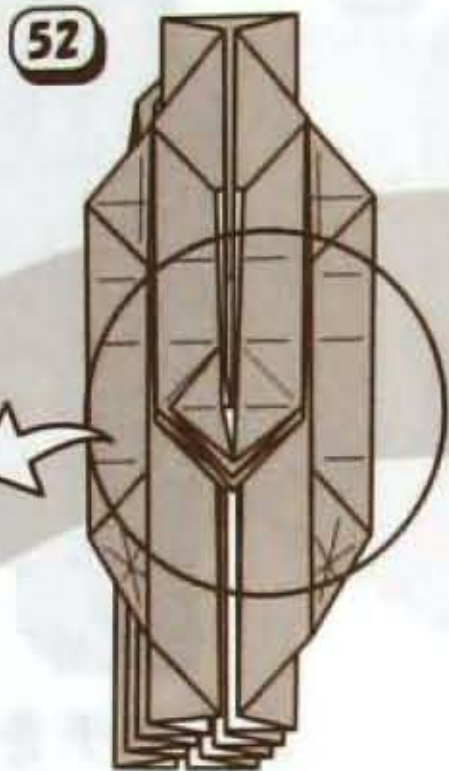

53 フチとフチを 合わせて 折り筋を つける



54 沈め折り (open sink)

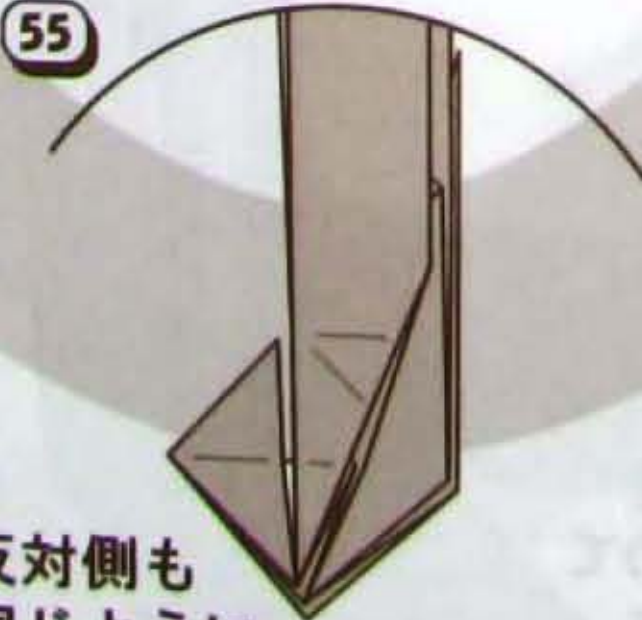

55 反対側も 同じように 折る

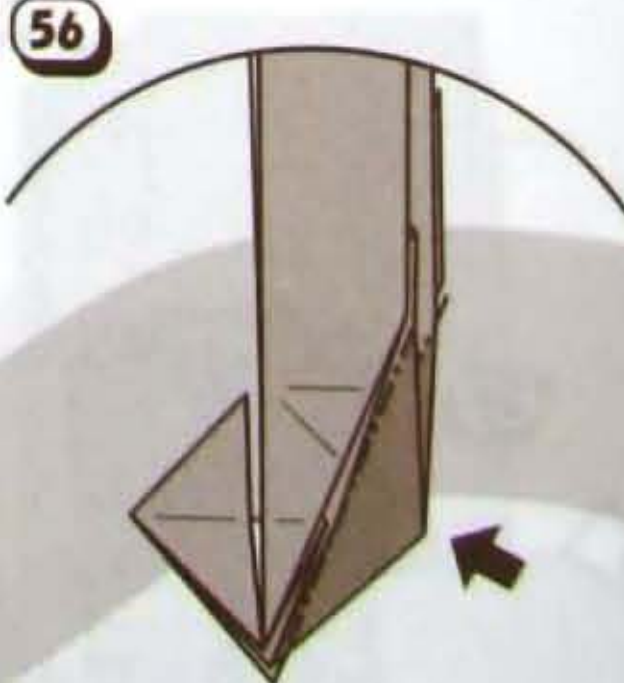

56 沈め折り (open sink)

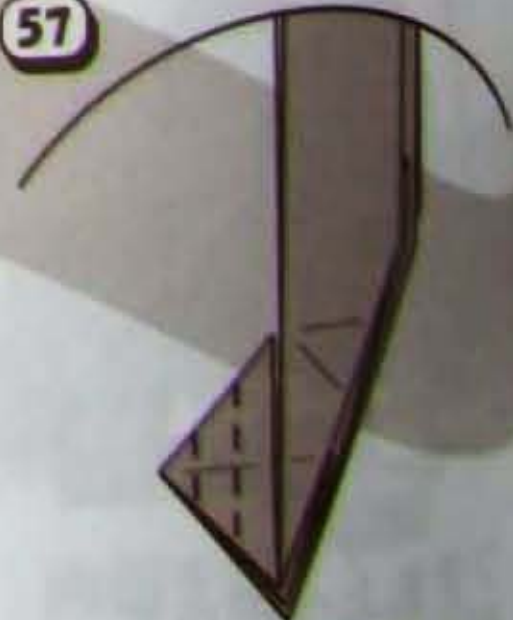

57 1/3の幅で 折り筋をつける

66

65

64

中書

58

つけた 多段沈 (open)

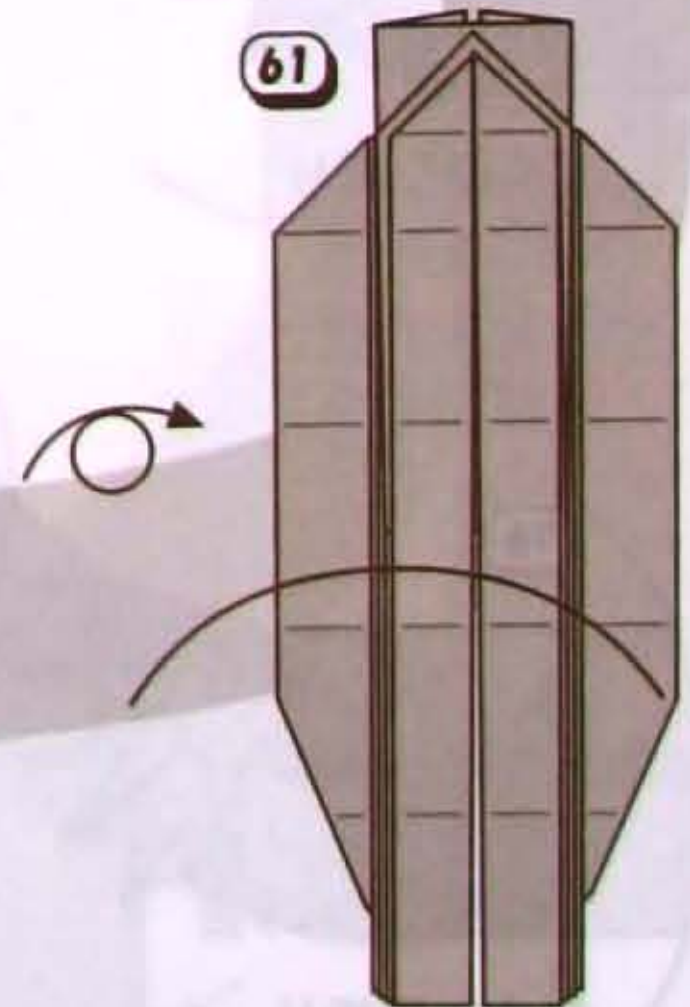
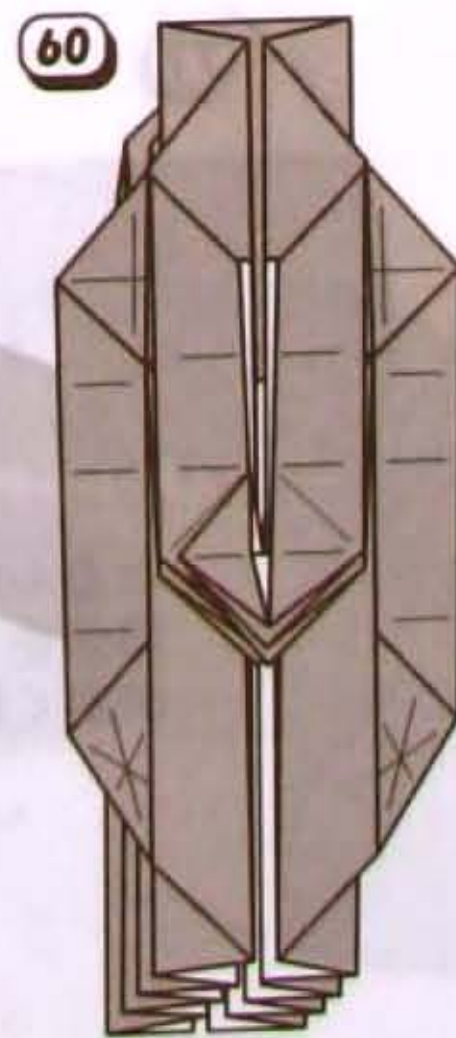
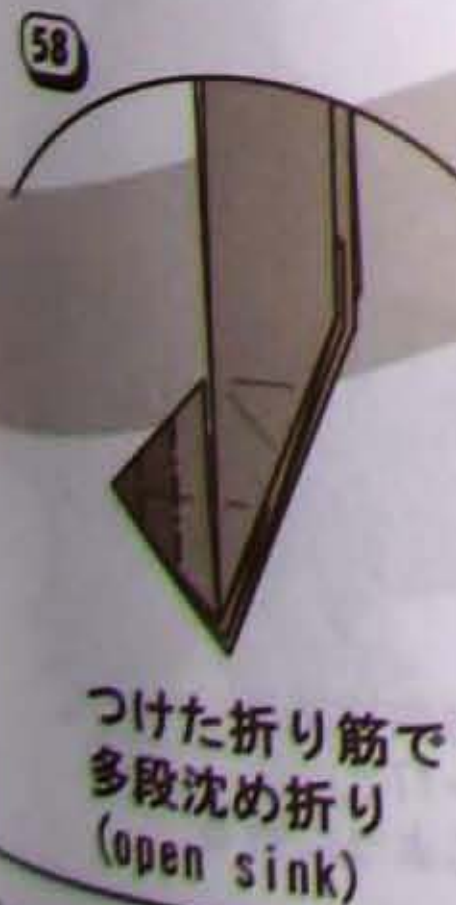
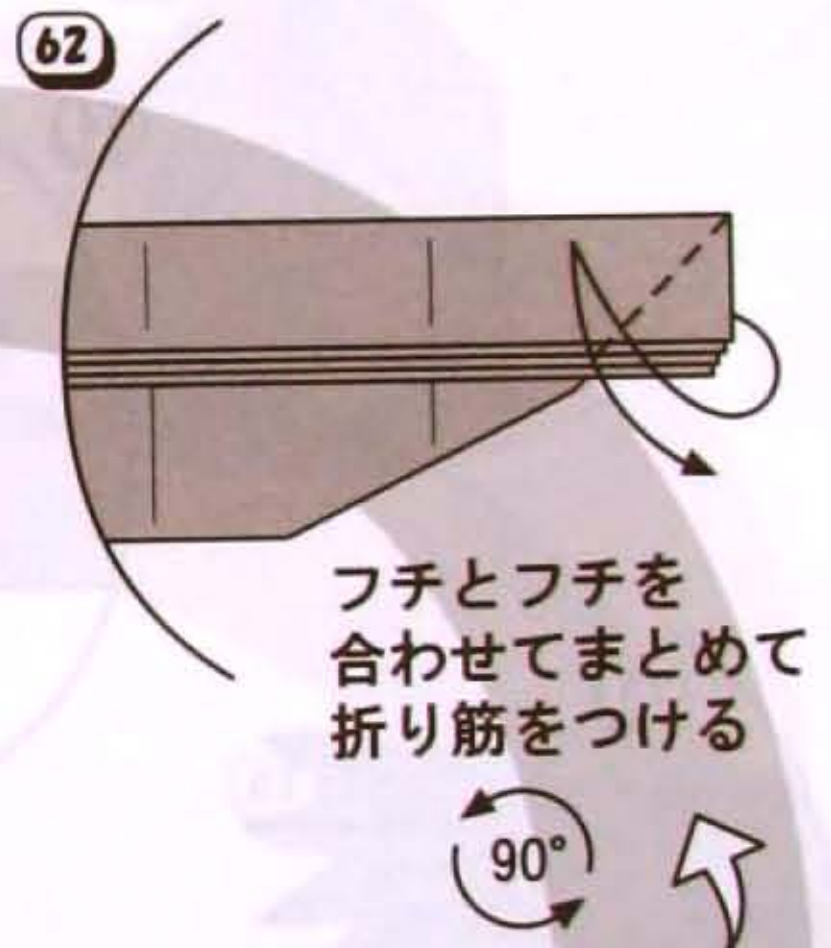
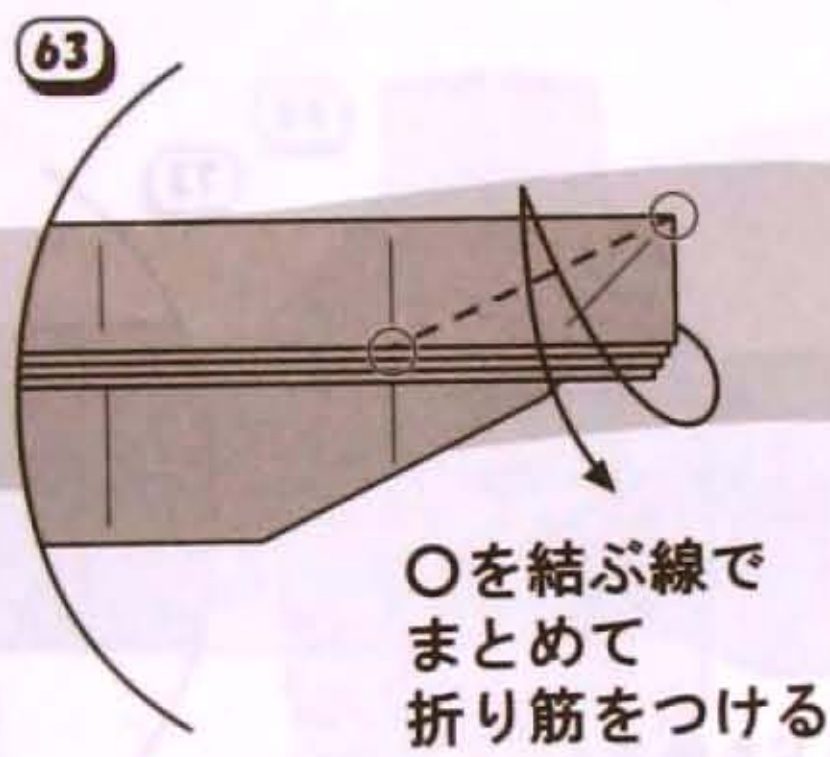
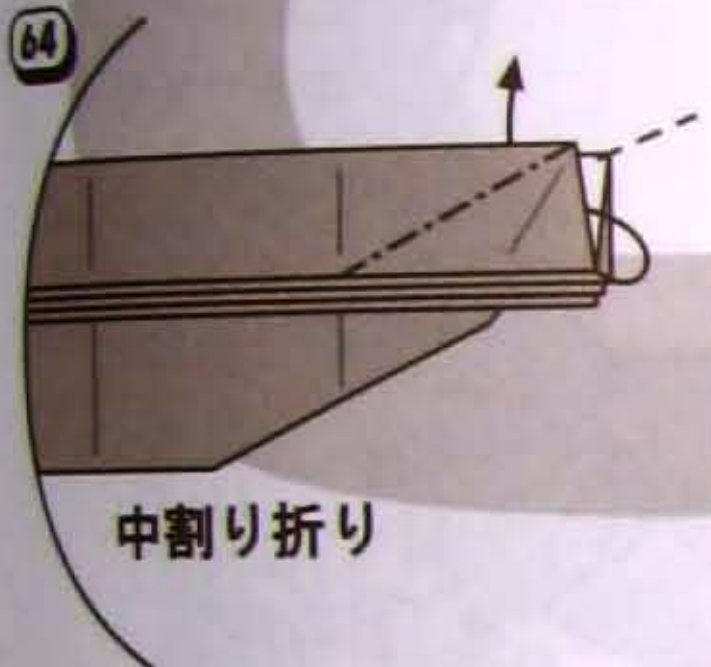
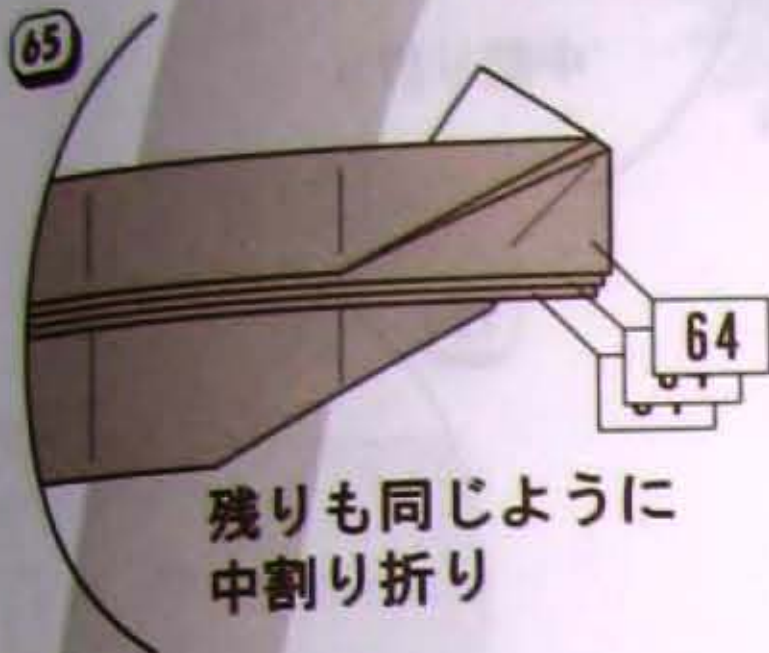
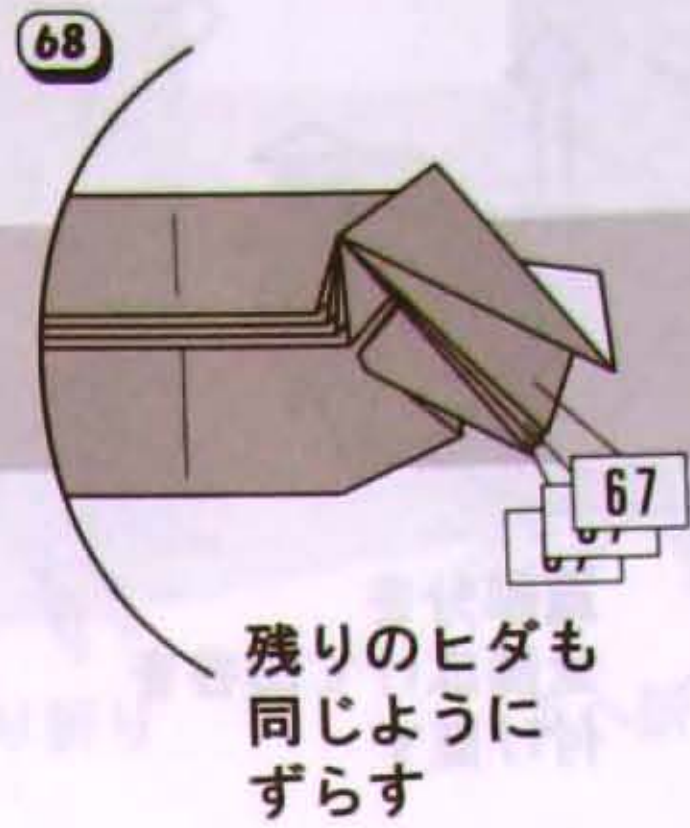
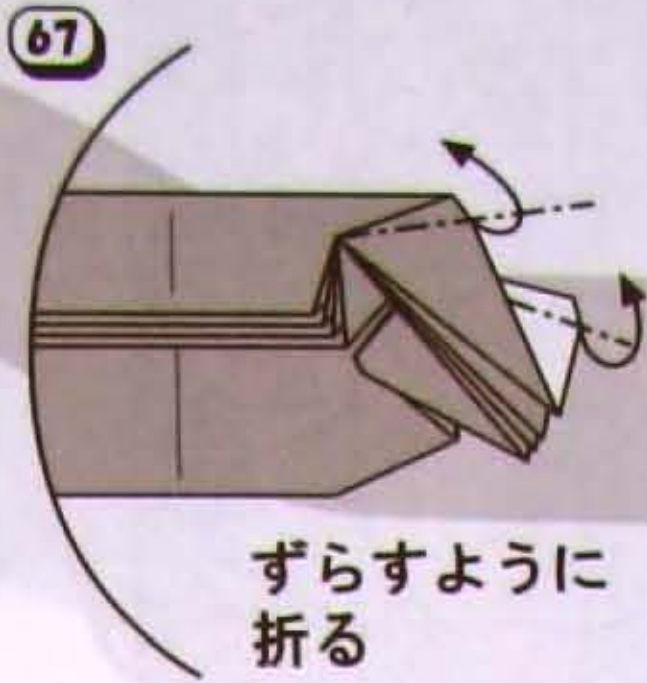

69

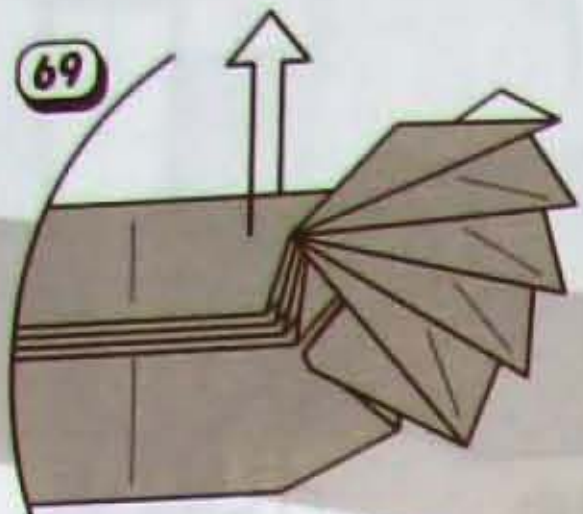

翼部分を
全部広げて山谷を
付け直す

70

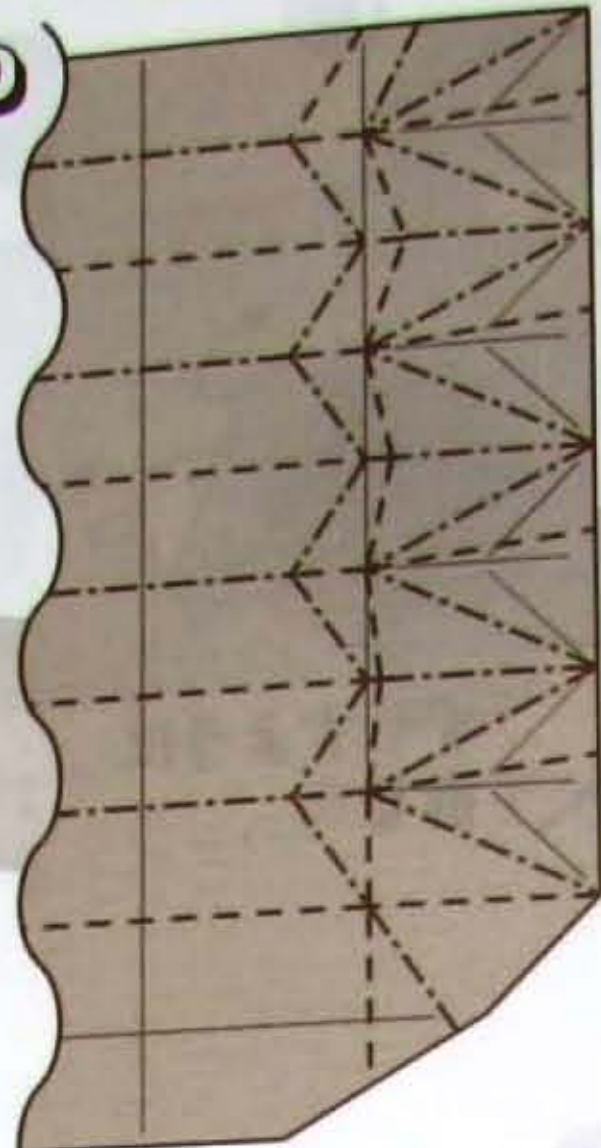

図のように山谷を
付け直して
折りたたむ

71

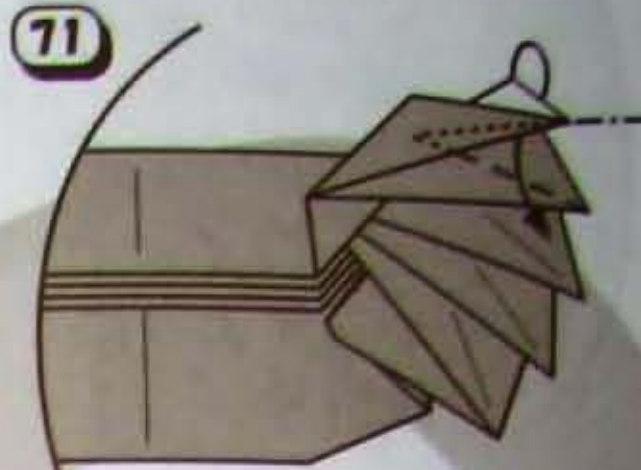

中割り折り

72



中割り折り

73

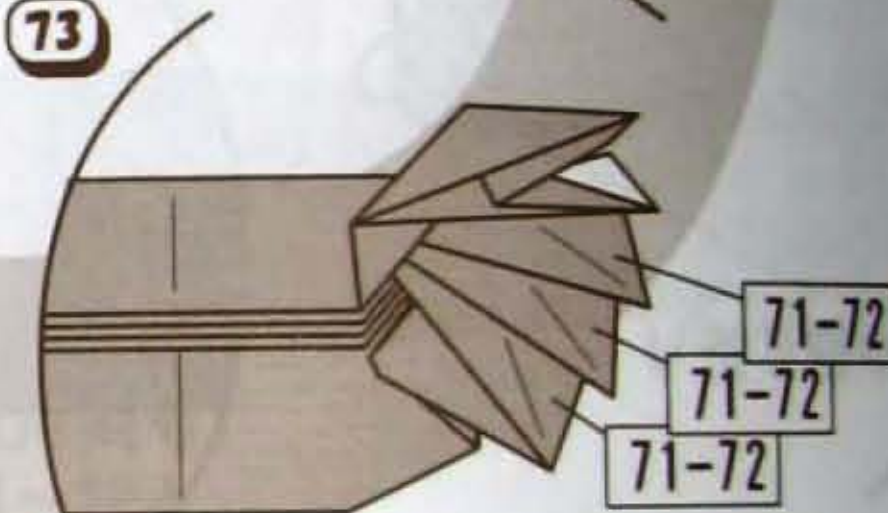

残りも71~72と
同じように折る

74

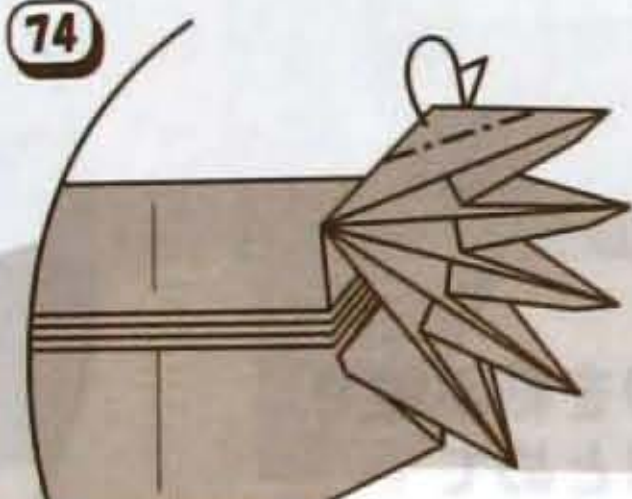

カドを後ろへ
折る

75



中割り折り

76

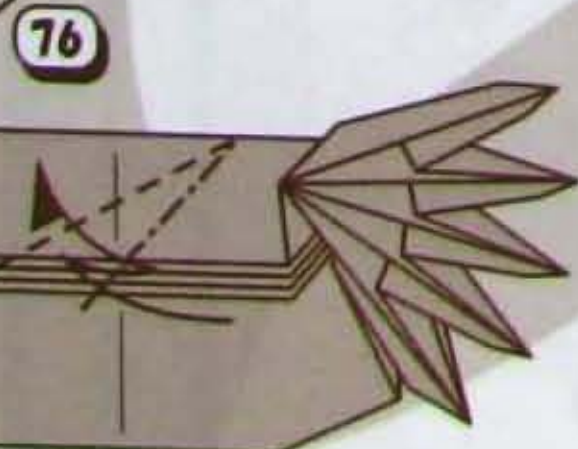

斜めに段折り

77



たるんだ
部分を
細かく段折り

78

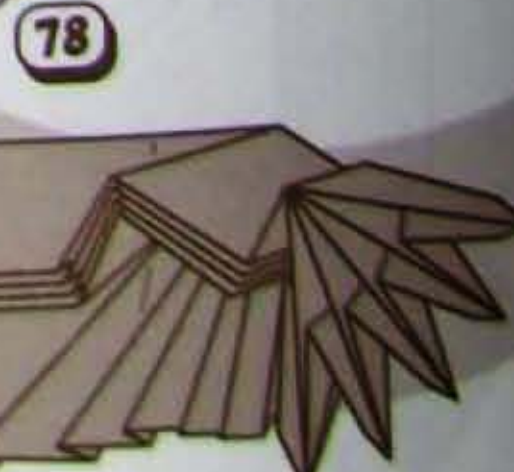

反対側の翼も
63~77と
同じように折る

86



カドを
下へ折

87



79



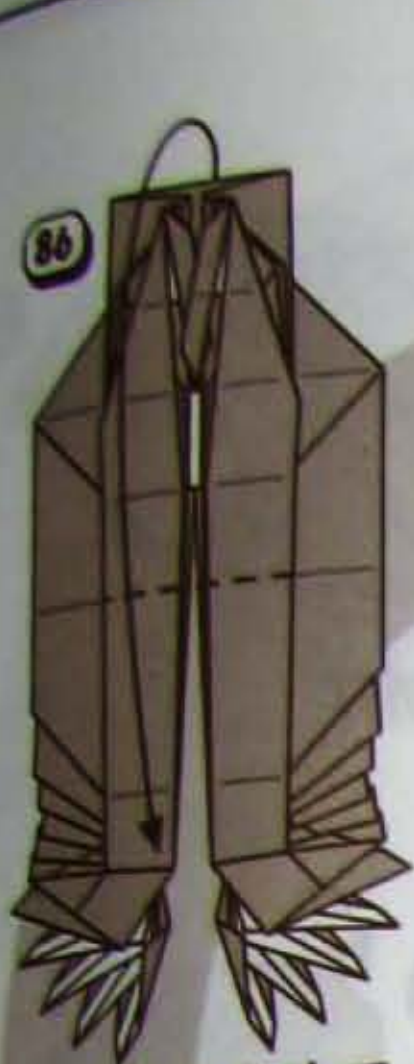

カドをまとめて
下へ折る

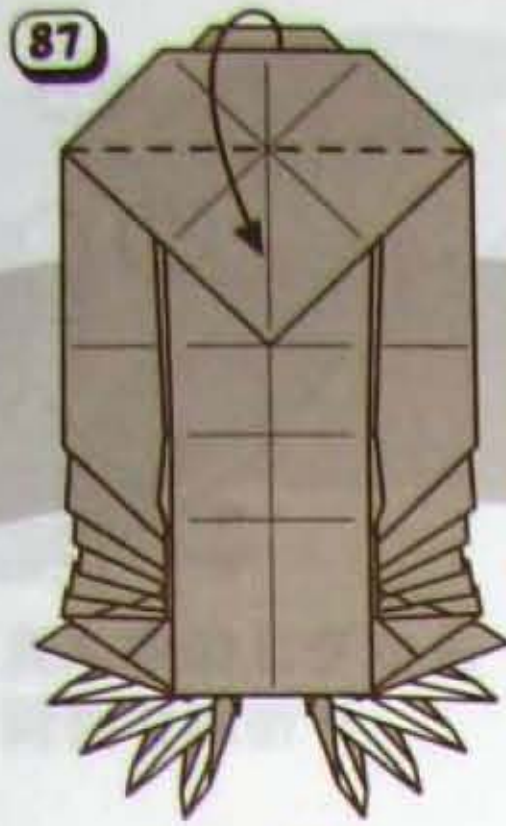

下へ折る

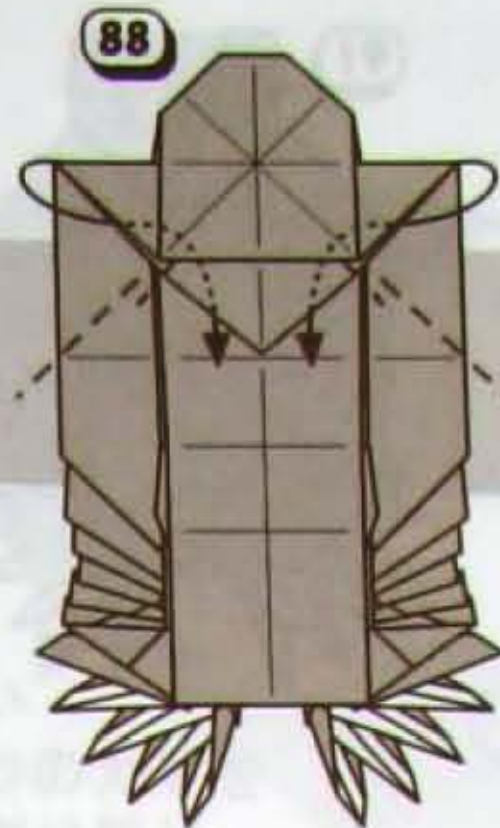

中割り折り

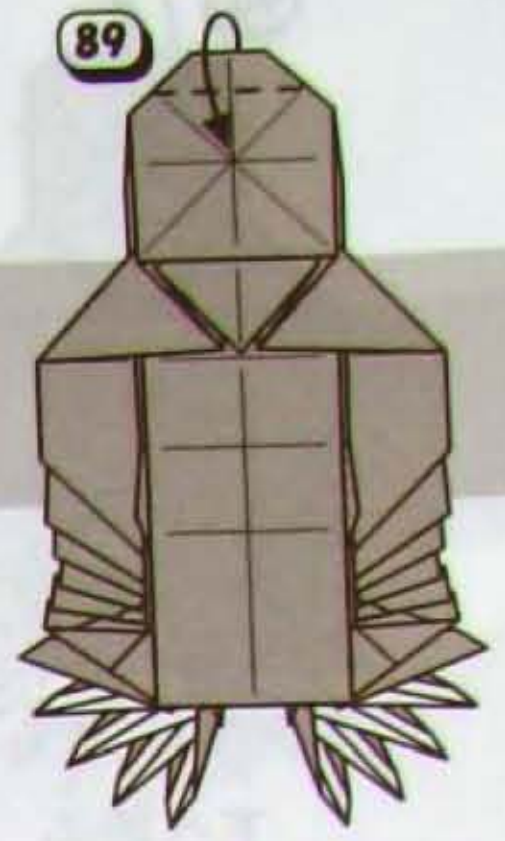

下へ折る

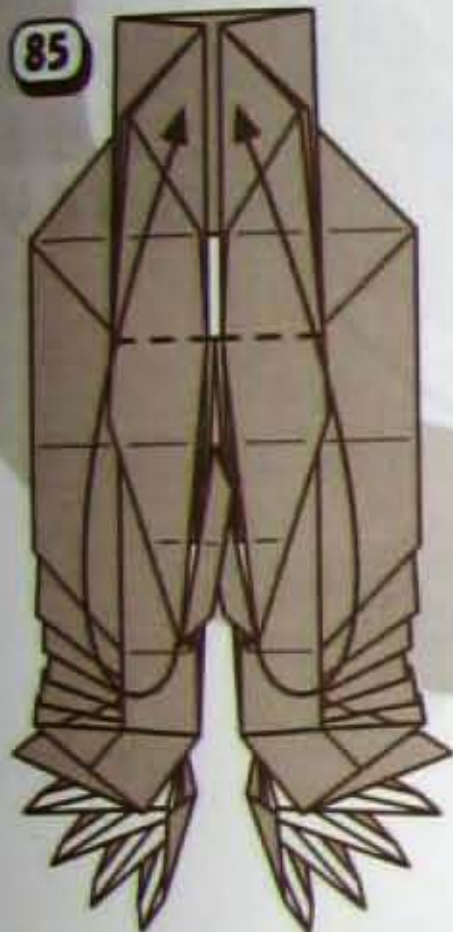

脚のカドを
上へ折る

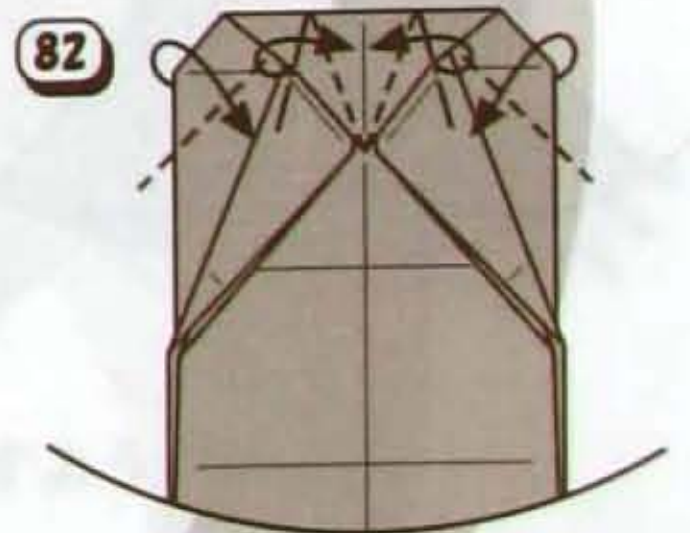
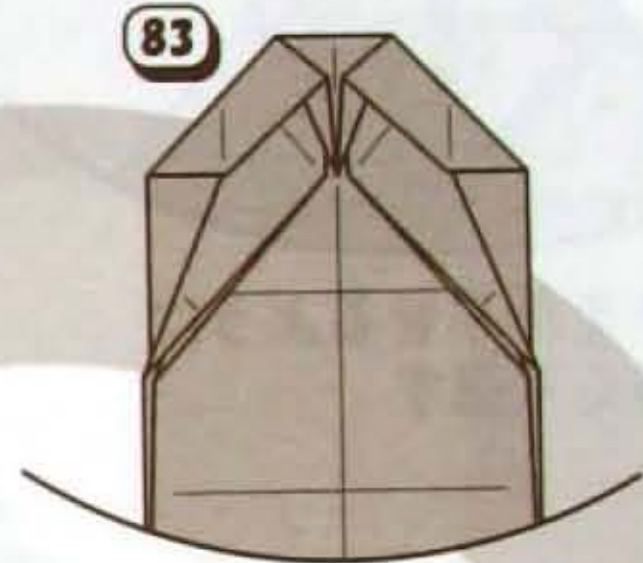
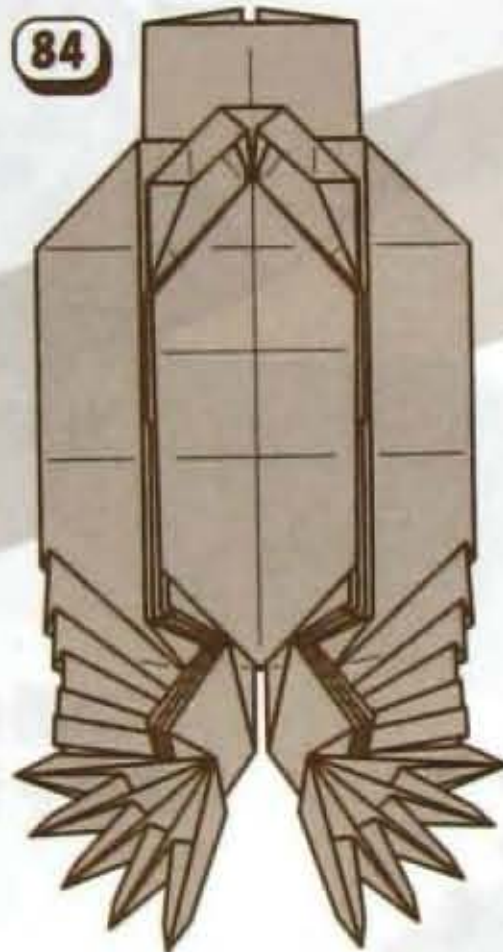

引きよせる
ように折る

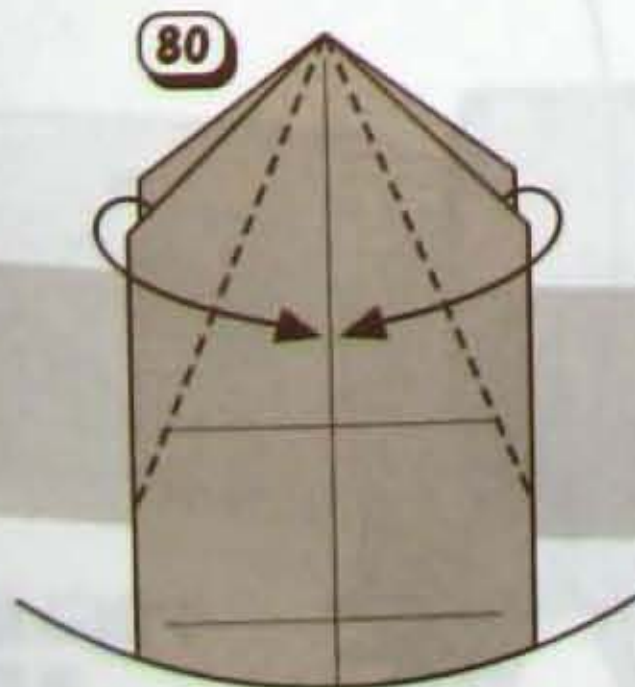
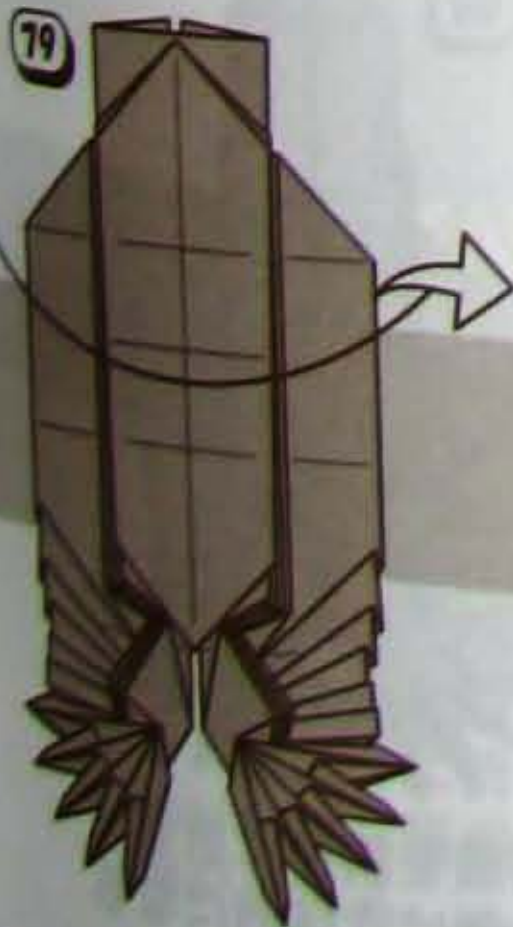

フチを折り筋に
合わせて折る

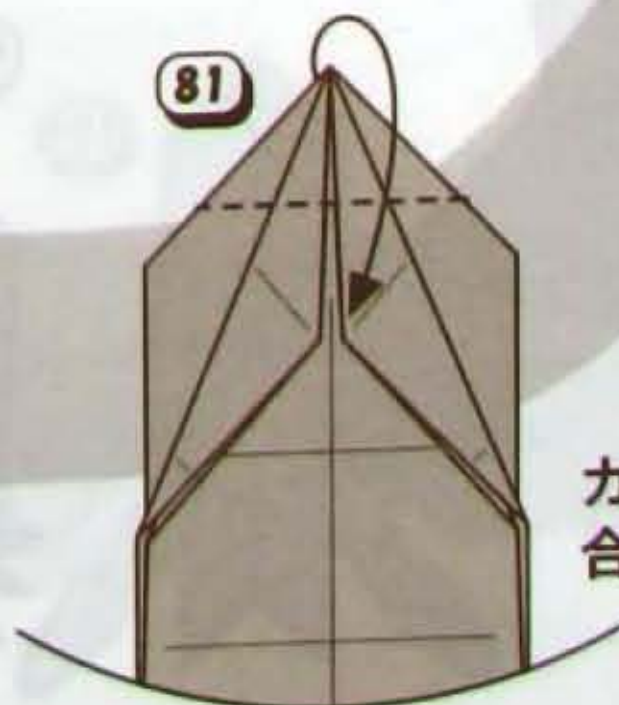

カドとカドを
合わせて折る

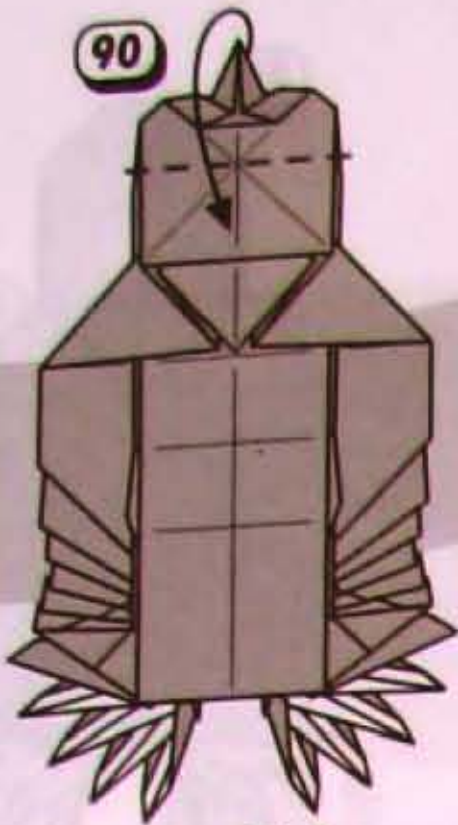

90 下へ折る

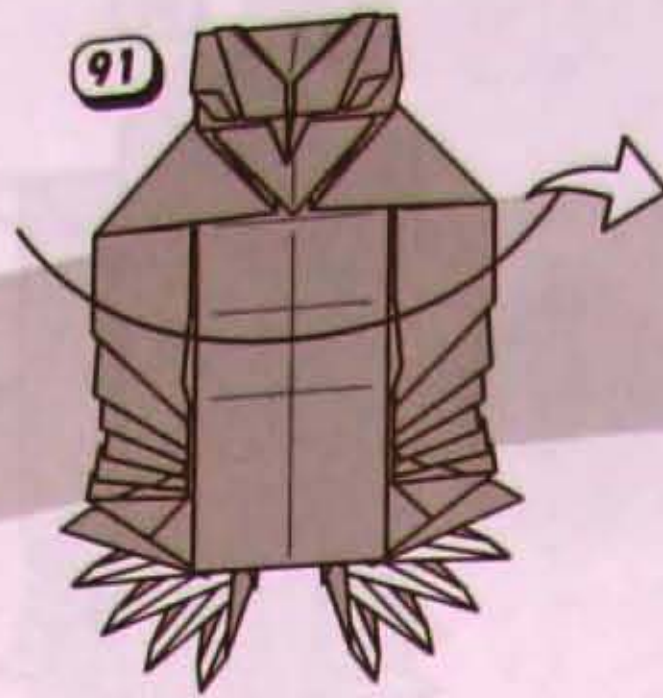

91

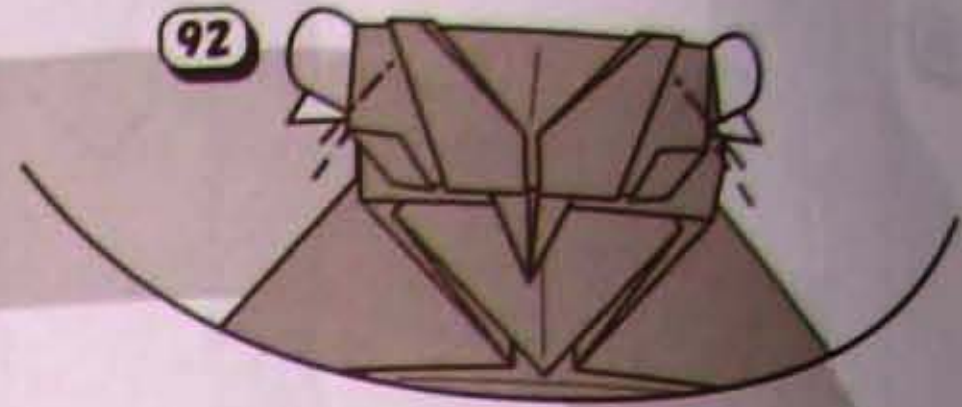

92

中割り折り



93

上の1枚をかぶせるようにひっくり返す

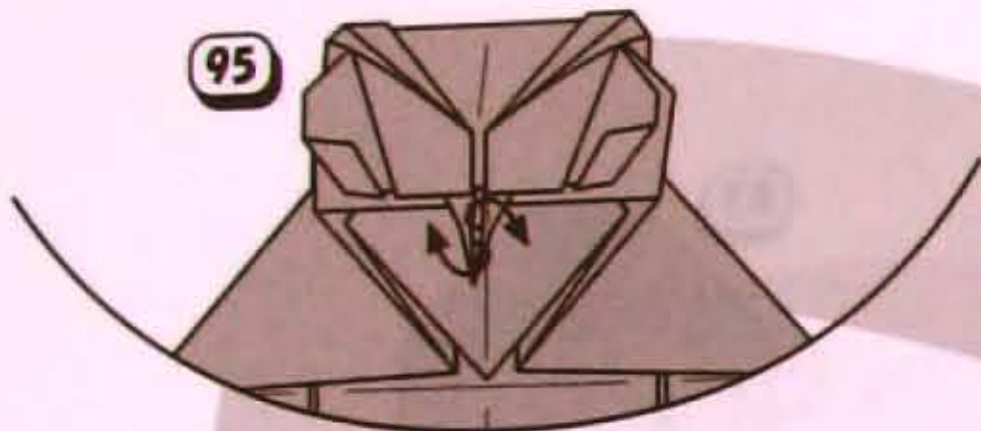

95

フチをかぶせるようにひっくり返す

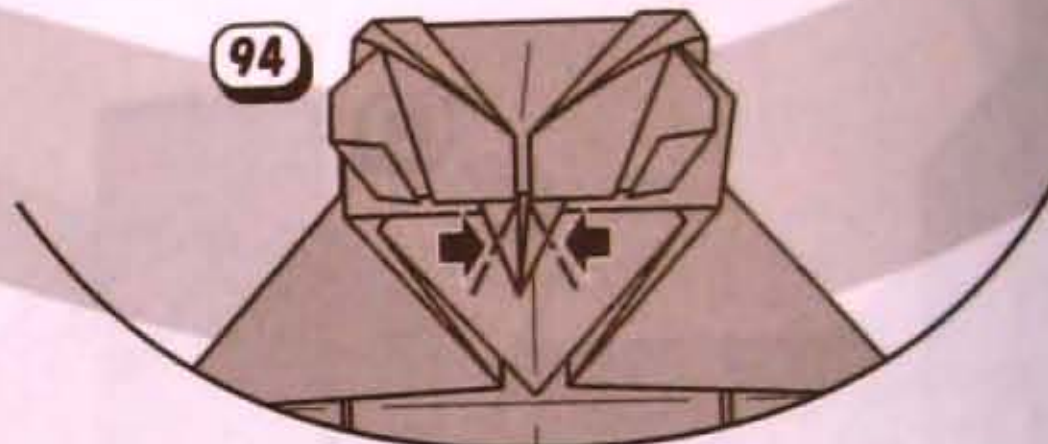

94

カドをつまむ

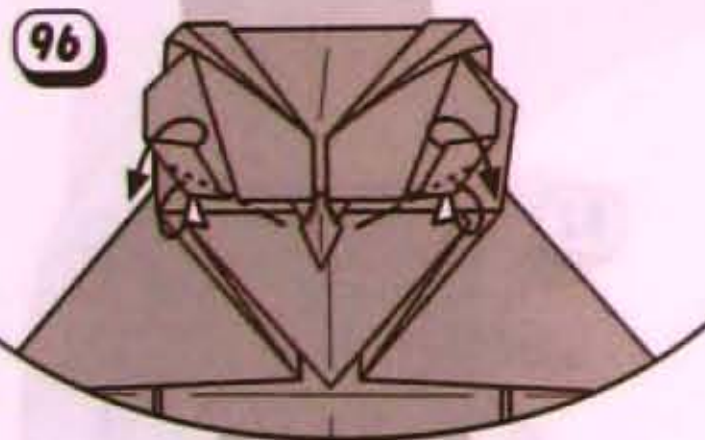

96

カドを後ろへ折りながら手前のカドをひろげる

Japão Burajirujin

www.japaoburajirujin.blogspot.com

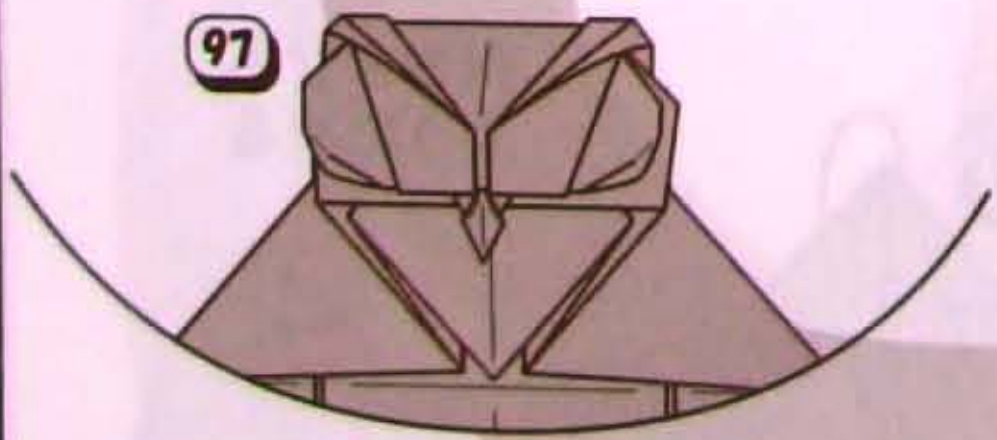

97

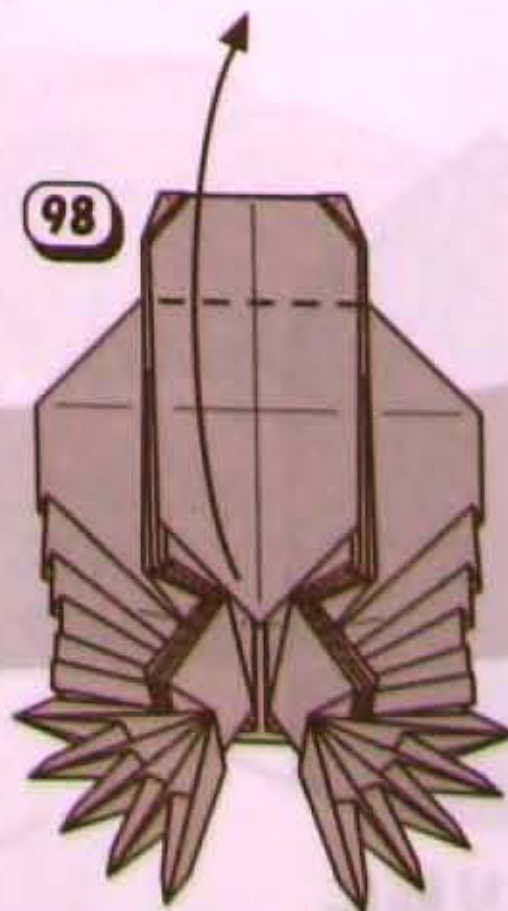

98

カドを上へ折る

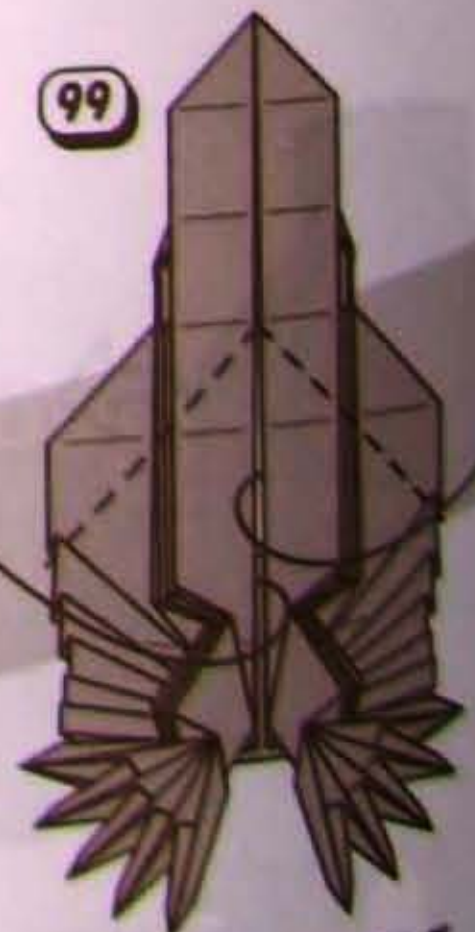

99

羽根を斜めに折る内側は立体的になる

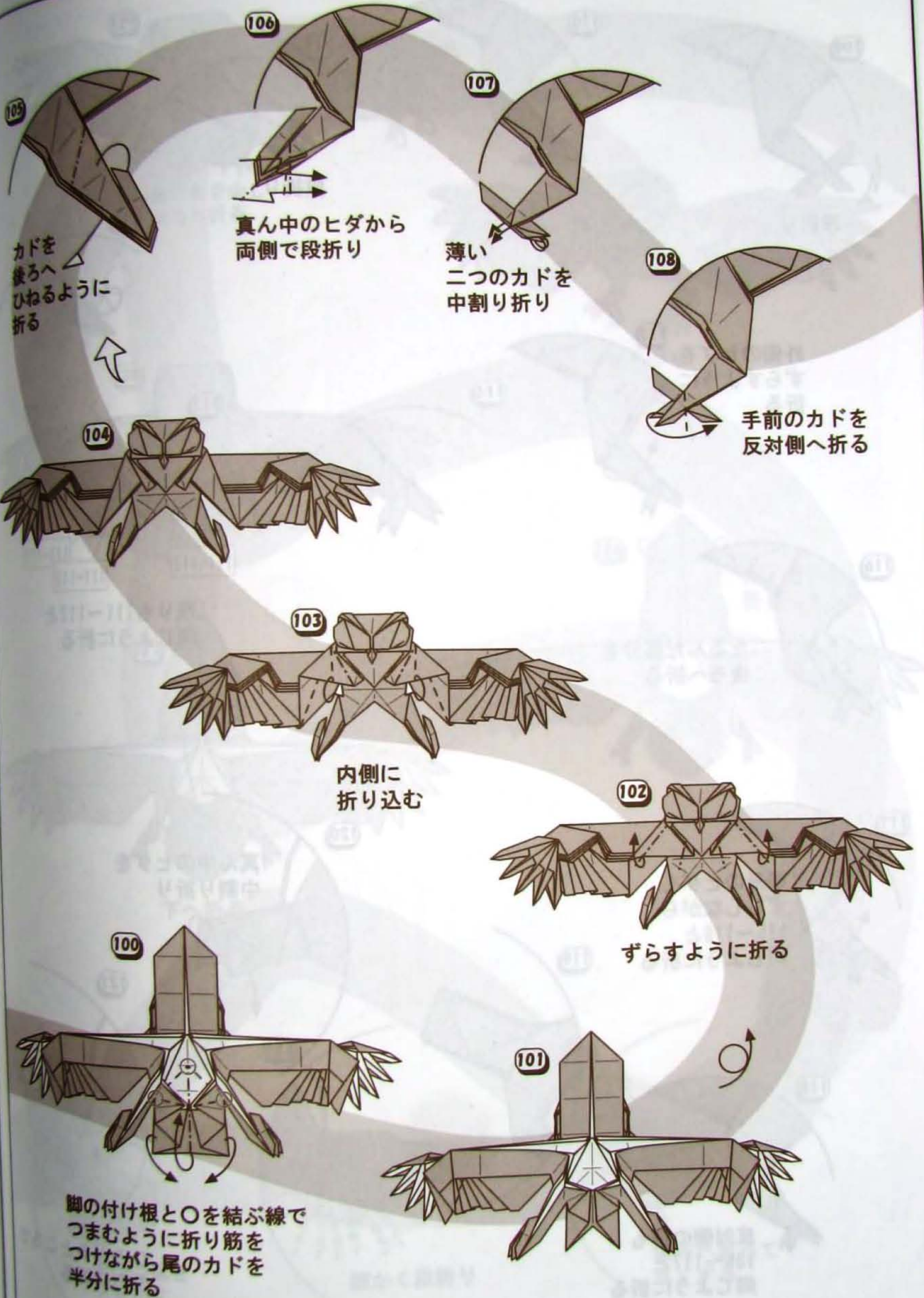

105
カドを後ろへひねるように折る

106
真ん中のヒダから両側で段折り

107
薄い二つのカドを中割り折り

108
手前のカドを反対側へ折る

104

103
内側に折り込む

102
ずらすように折る

100
脚の付け根と○を結ぶ線をつまむように折り筋をつけながら尾のカドを半分に折る

101

をよように返す

折るになる

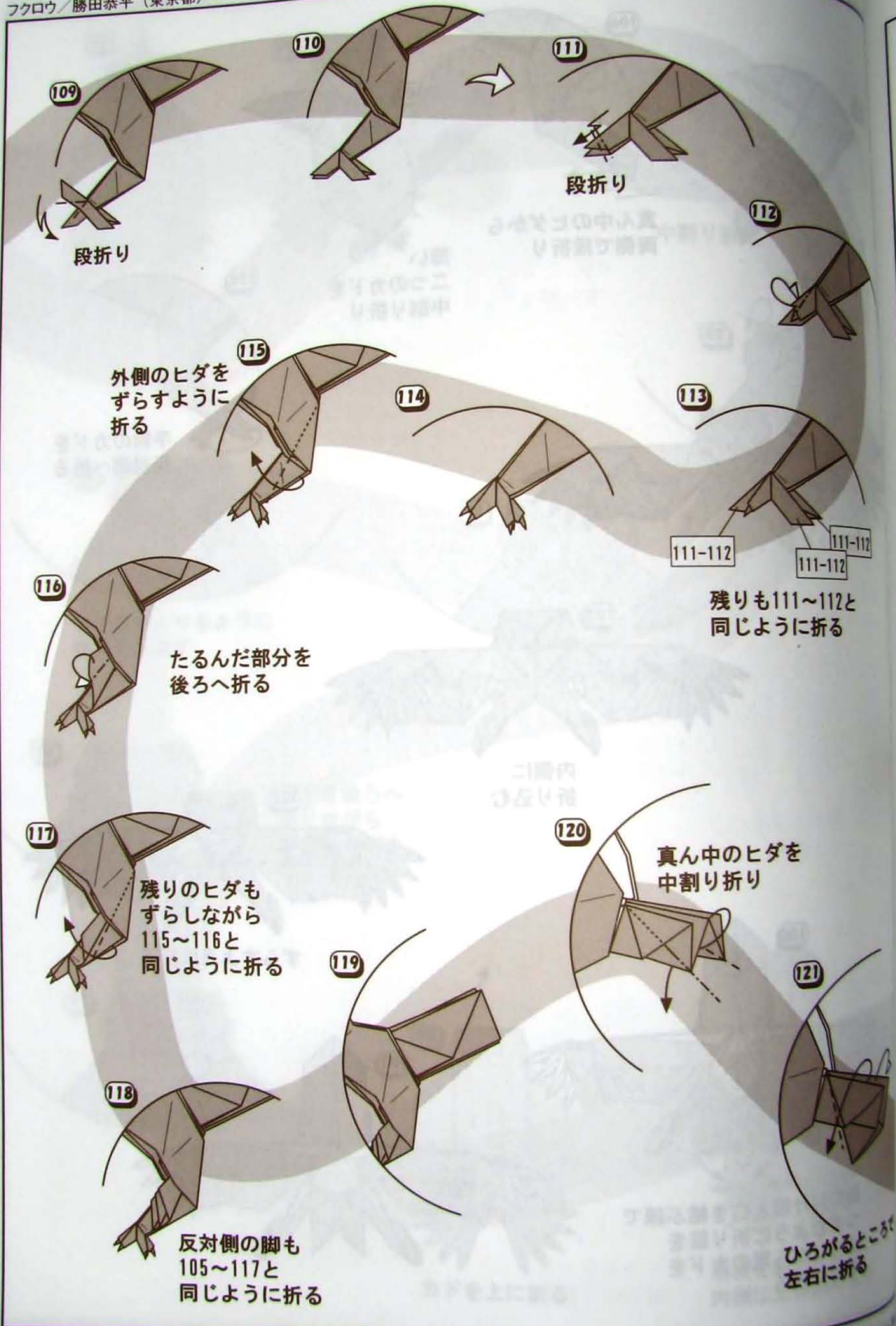

段折り

段折り

外側のヒダをずらすように折る

残りも111~112と同じように折る

たるんだ部分を後ろへ折る

残りのヒダもずらしながら115~116と同じように折る

反対側の脚も105~117と同じように折る

真ん中のヒダを中割り折り

ひろがるところで左右に折る

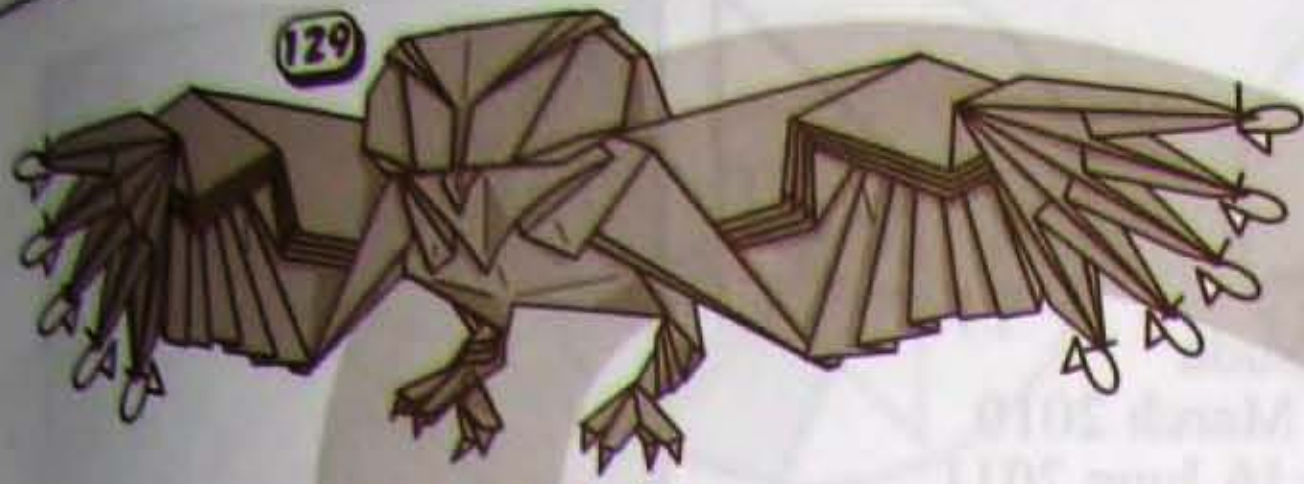

129
翼の先を少し
後ろへ折る



130
できあがり

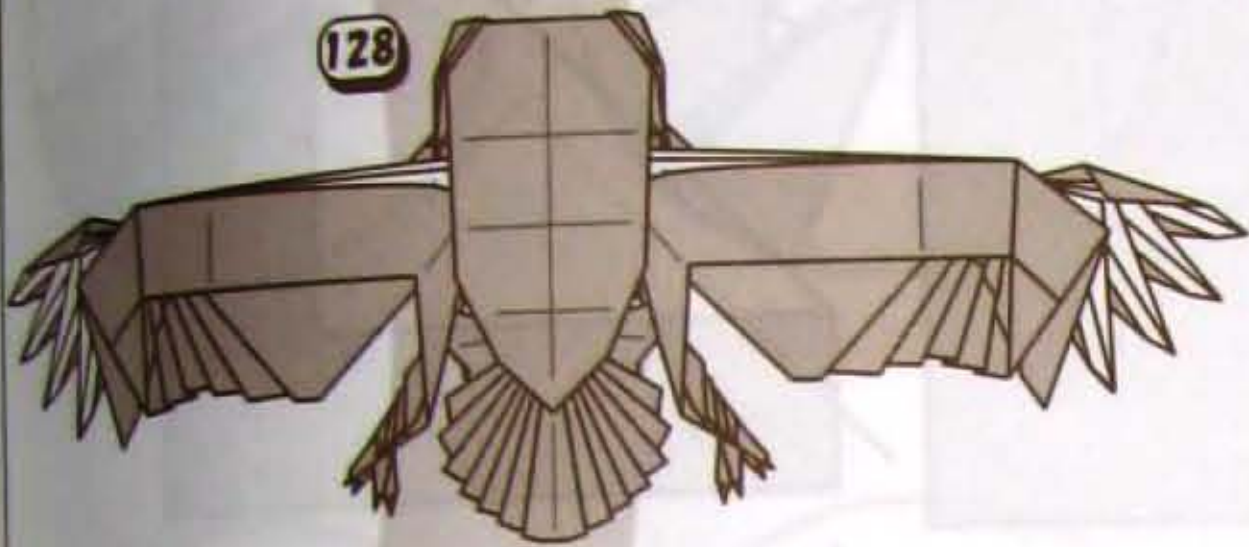

128

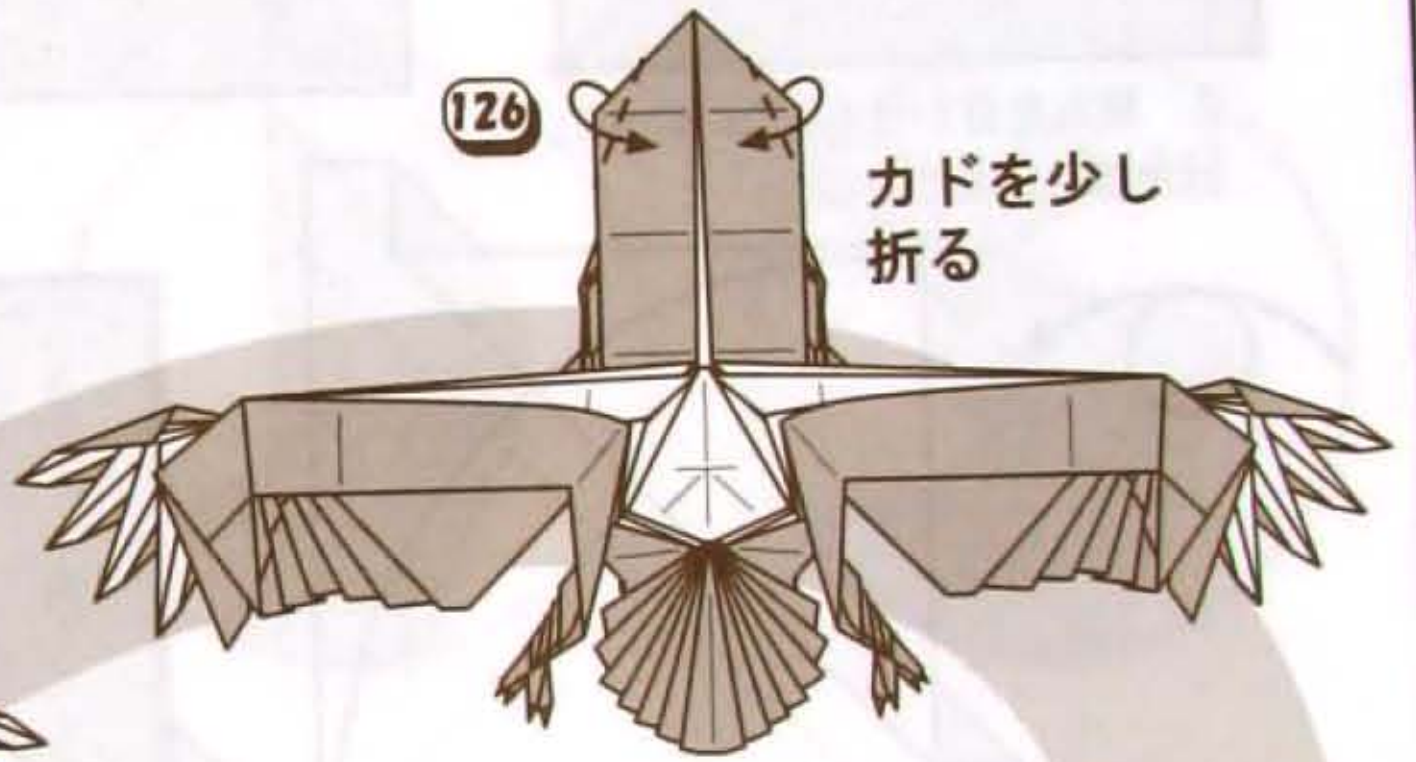

126

カドを少し
折る

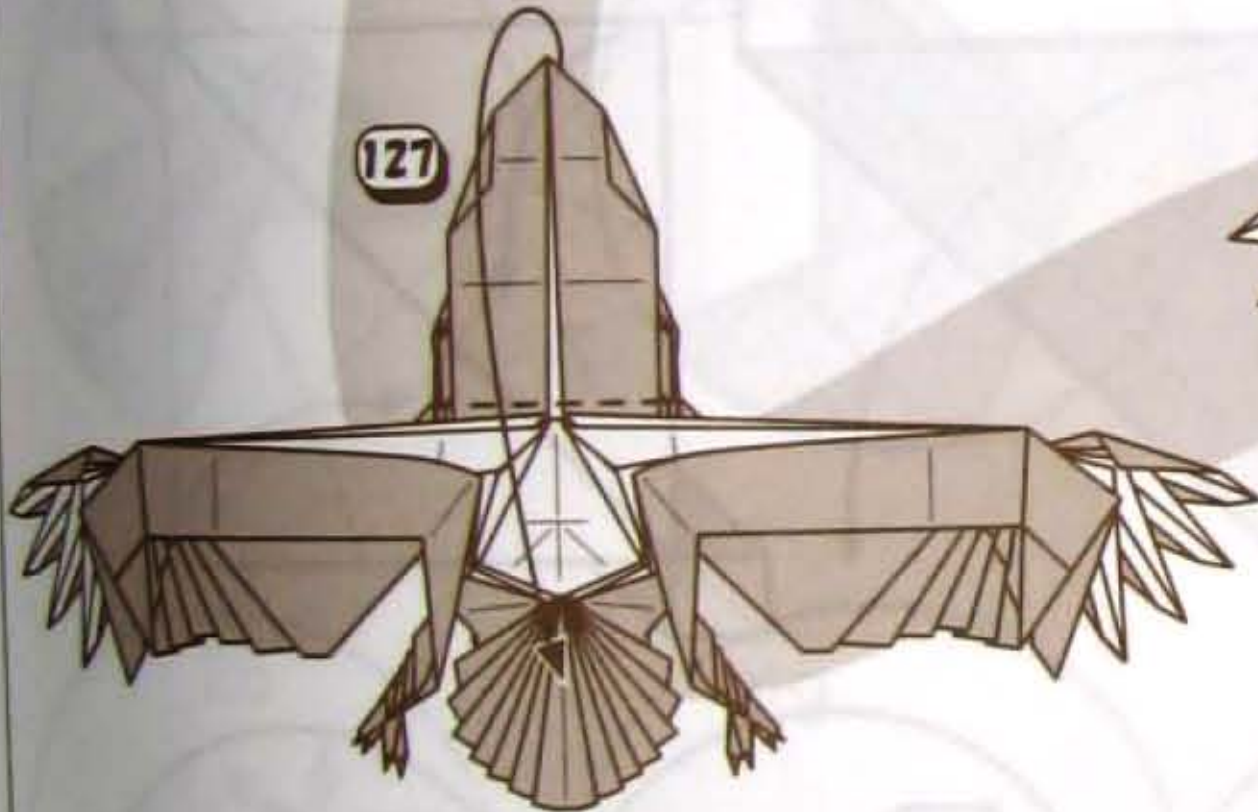

127

下へ折る

125

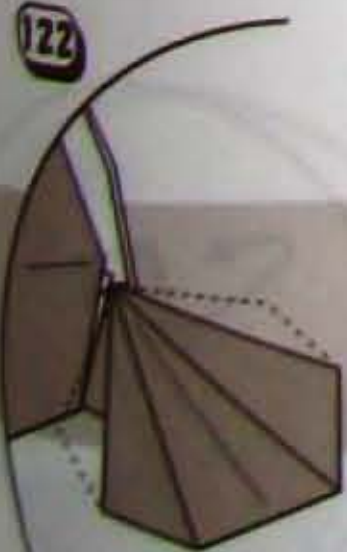
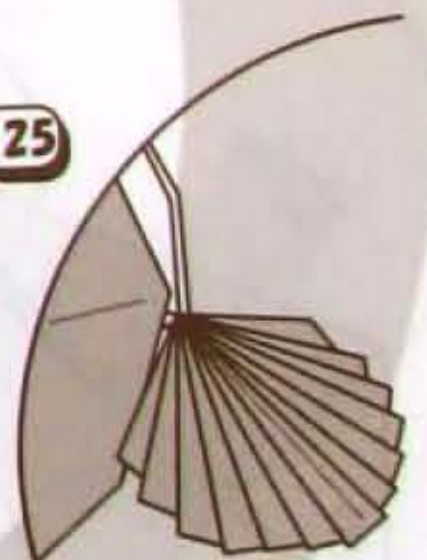

122

後ろの紙を
引き出す

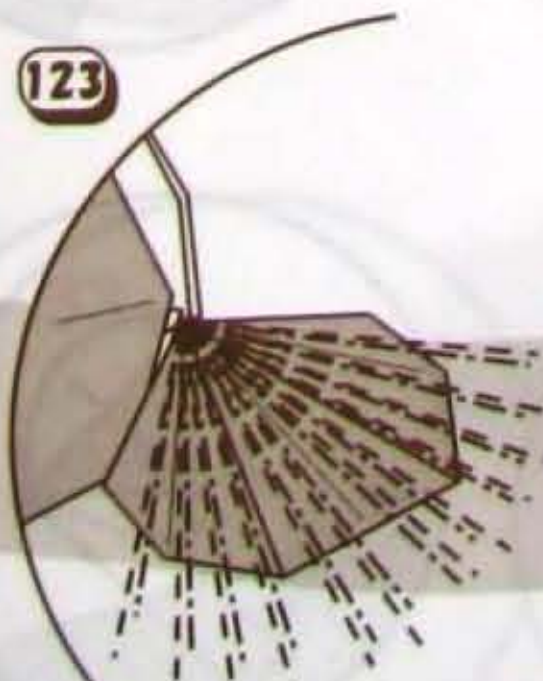

123

細かく段折り

124



後ろへ折って
丸くする

るところで
折る

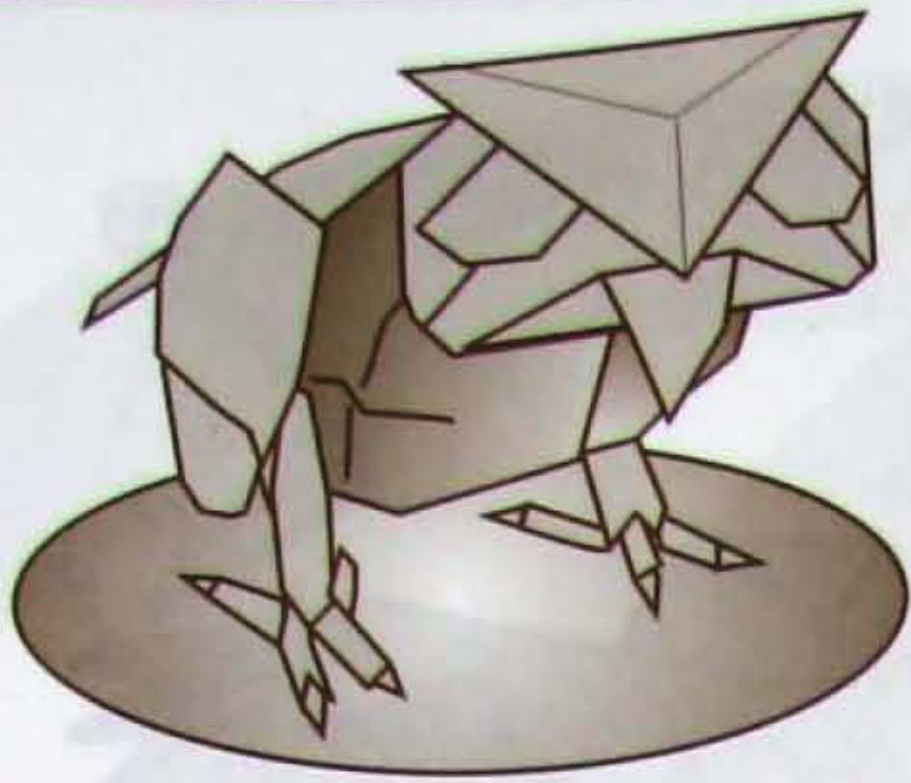

"Owl #2"
 Yoshio Tsuda
 Created: March 2010
 Diagram: 16 June 2011
 Recommended paper size:
 20cm x 20cm

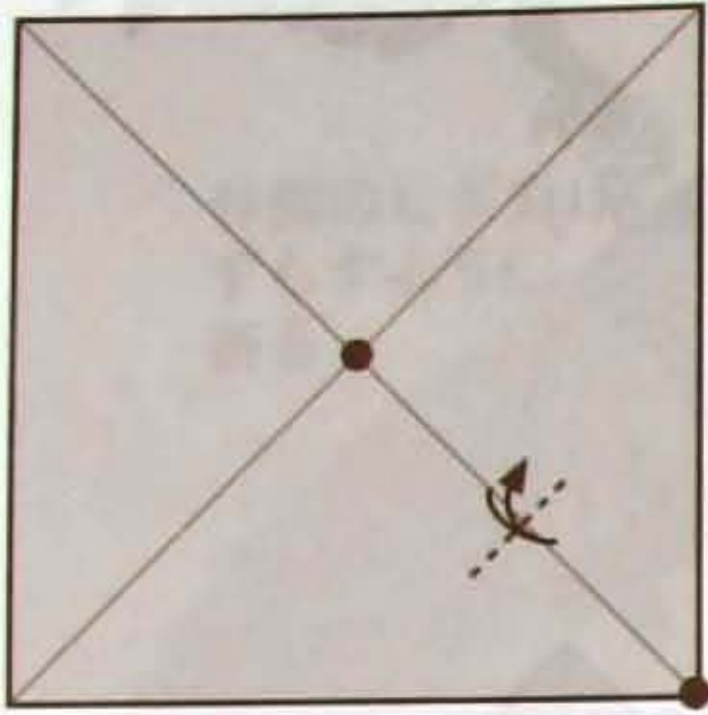
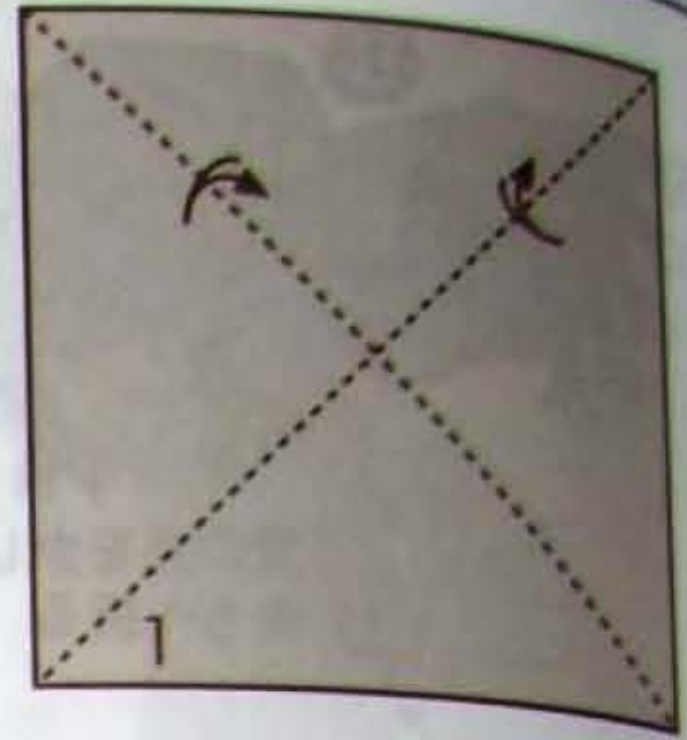

2 黒丸を合わせるように折って、
 対角線に印をつける。

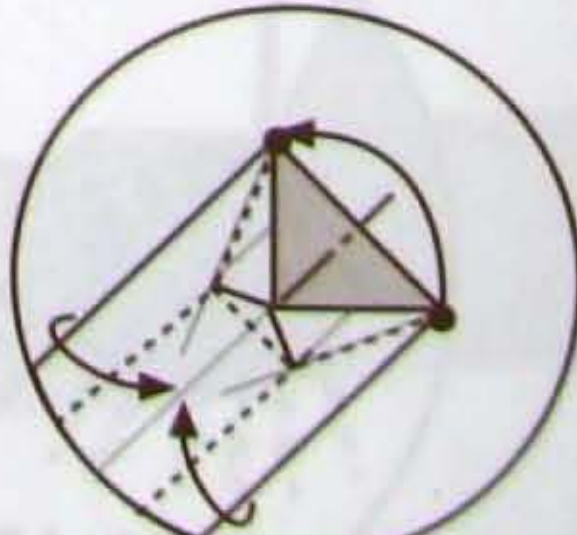
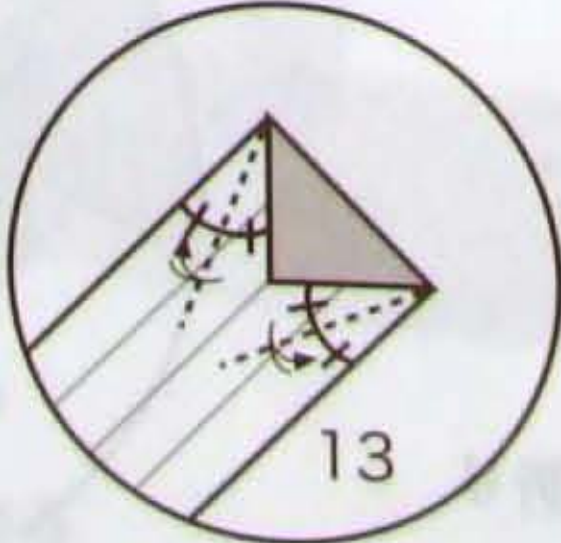
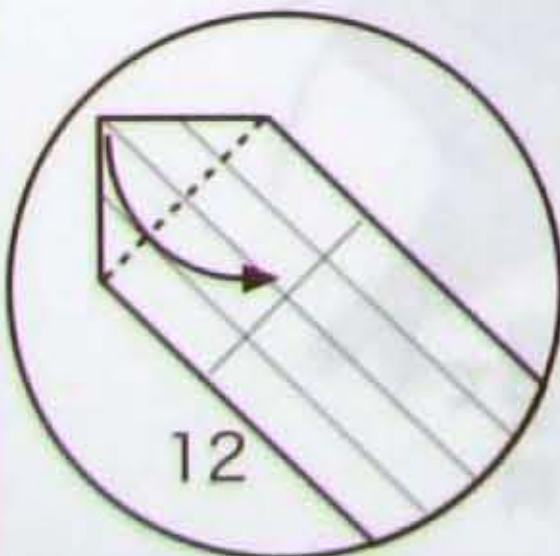
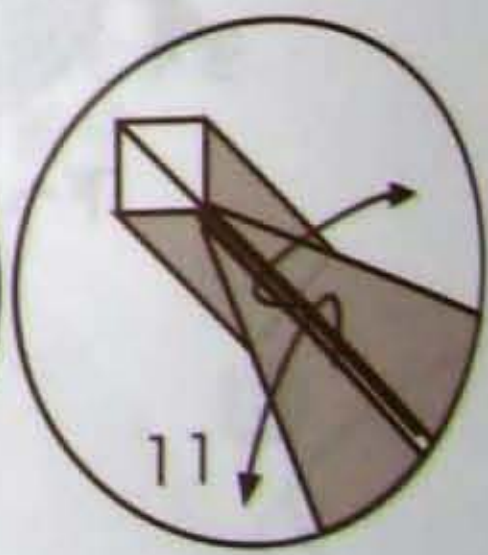
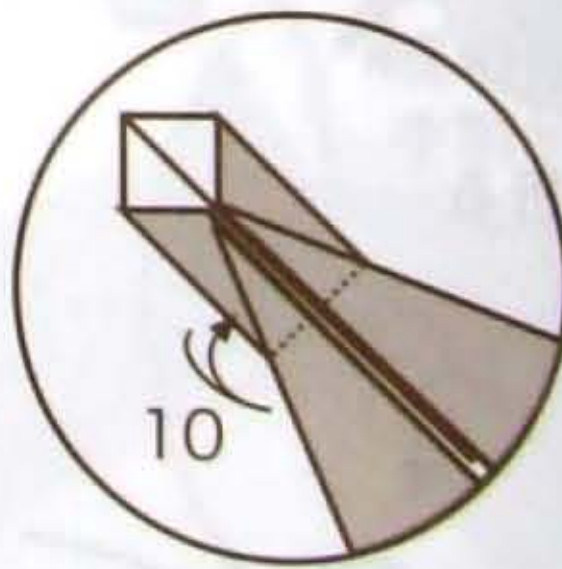
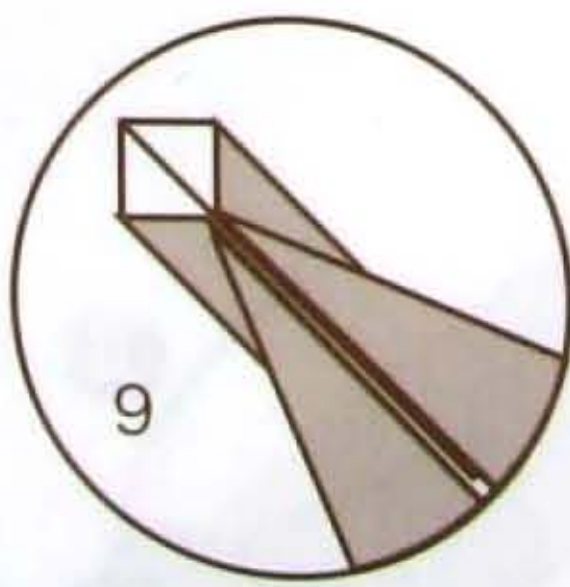
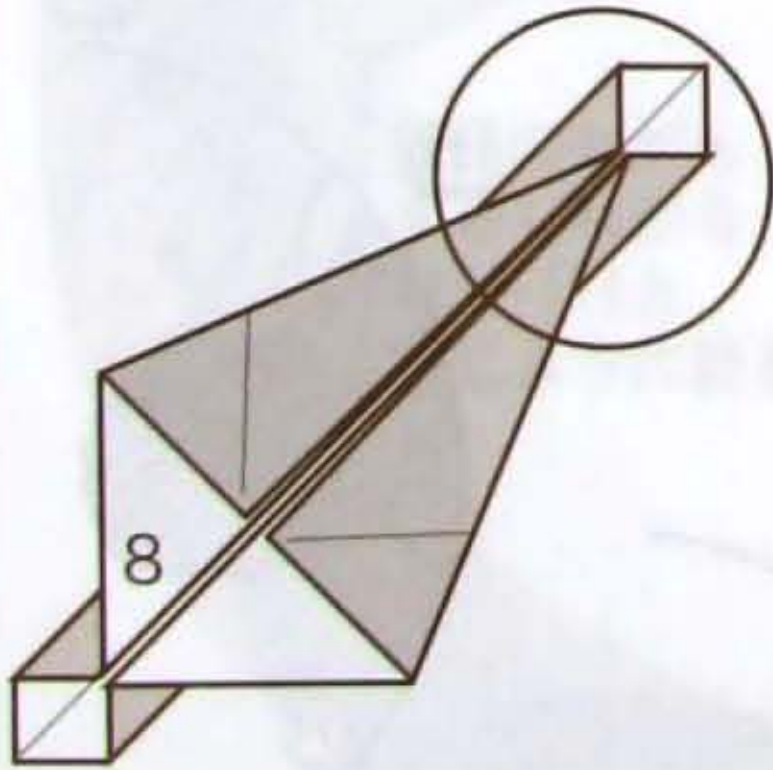
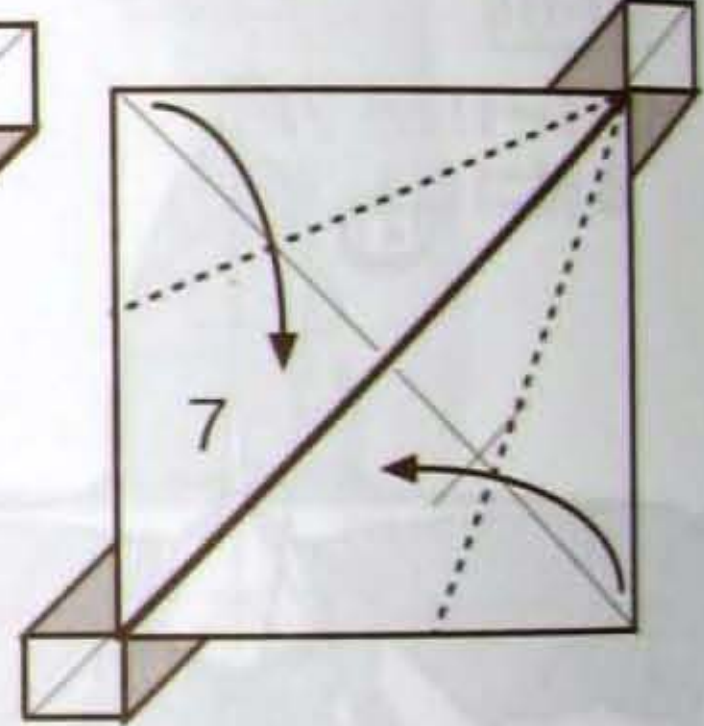
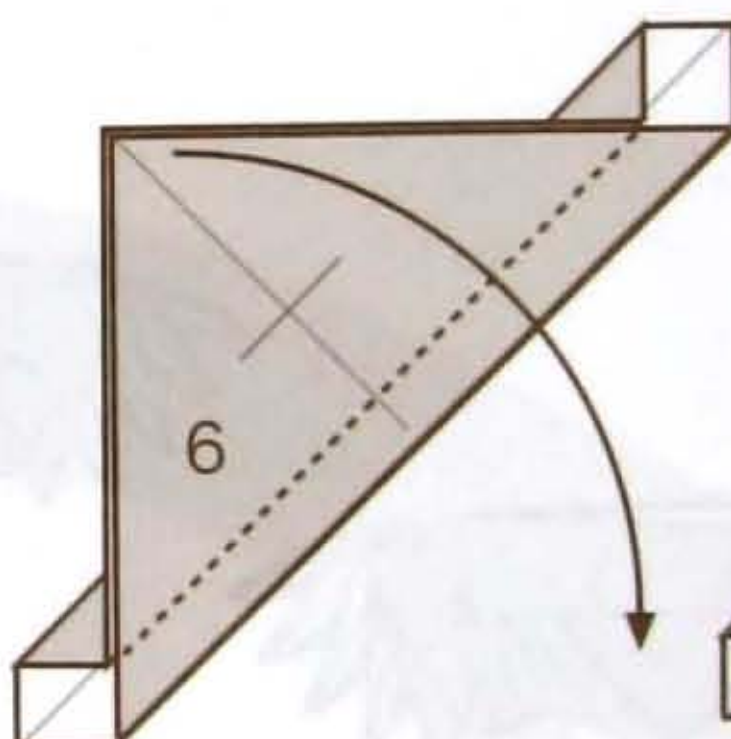
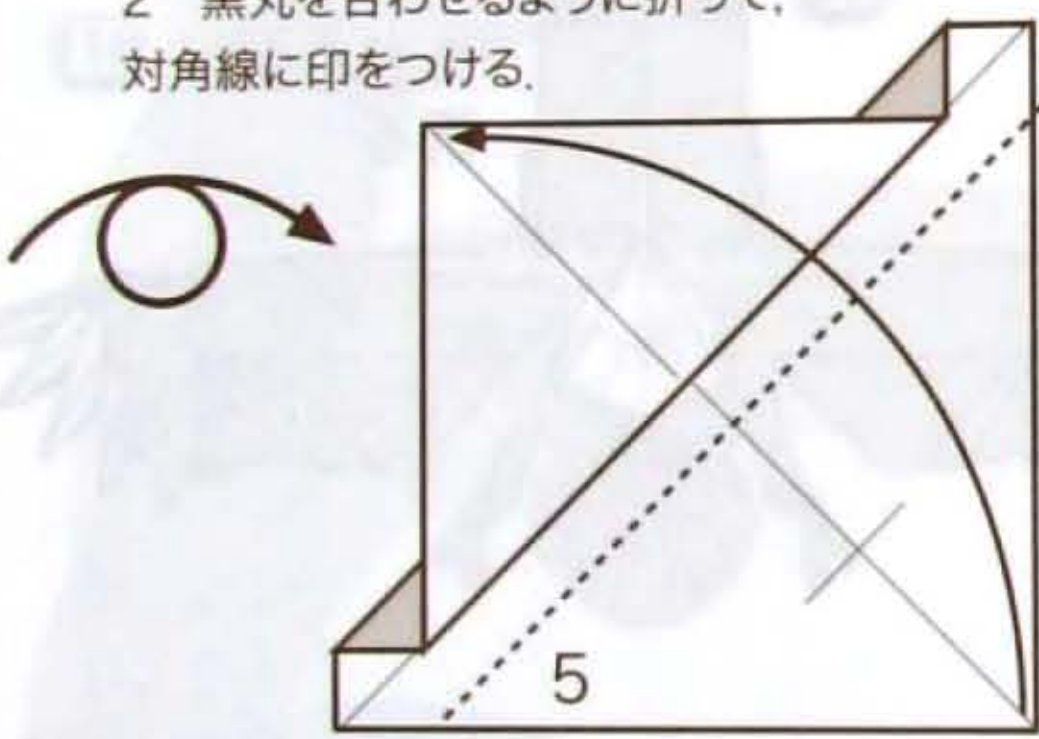
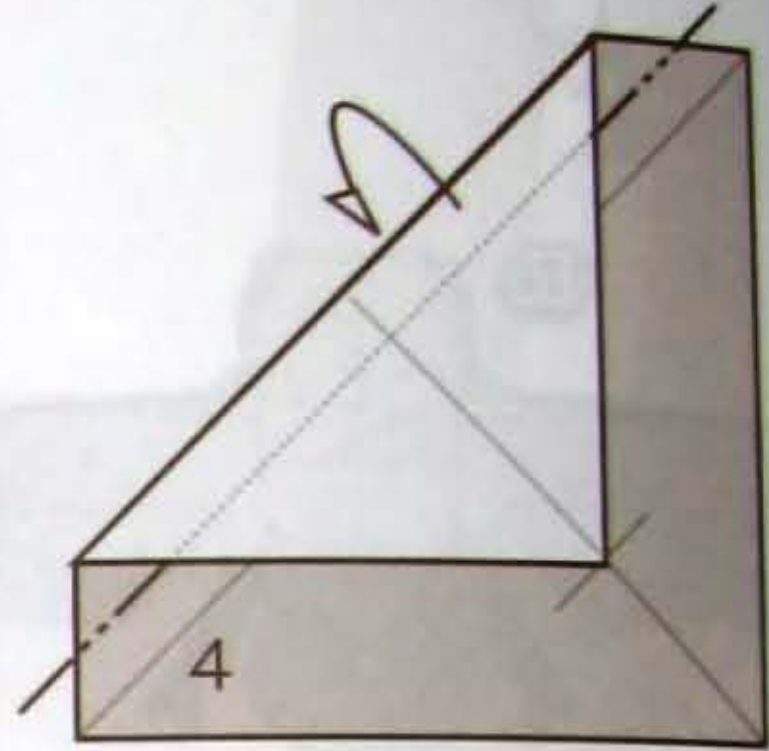
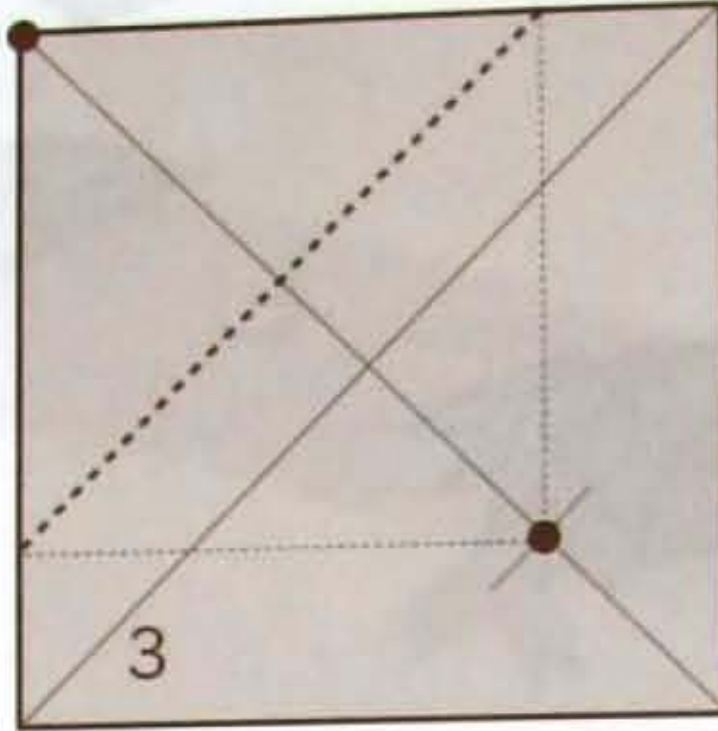

14 黒丸を合わせるように
 折りたたむ。



15 立ち上がった三角
 部分を横に倒す。

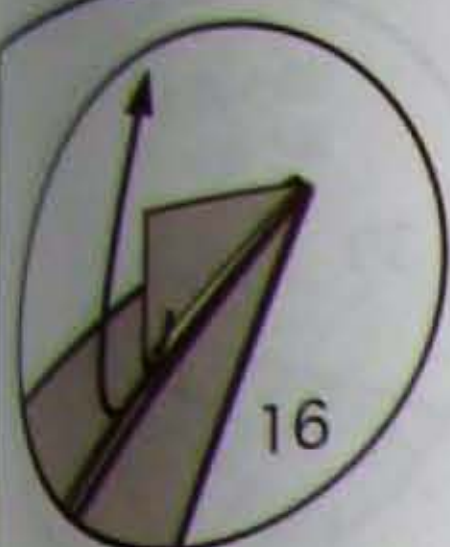

重なっている紙を
広げる。

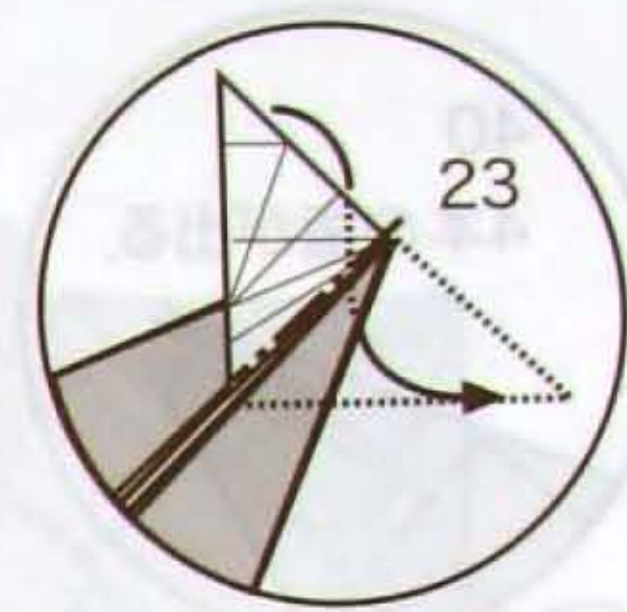
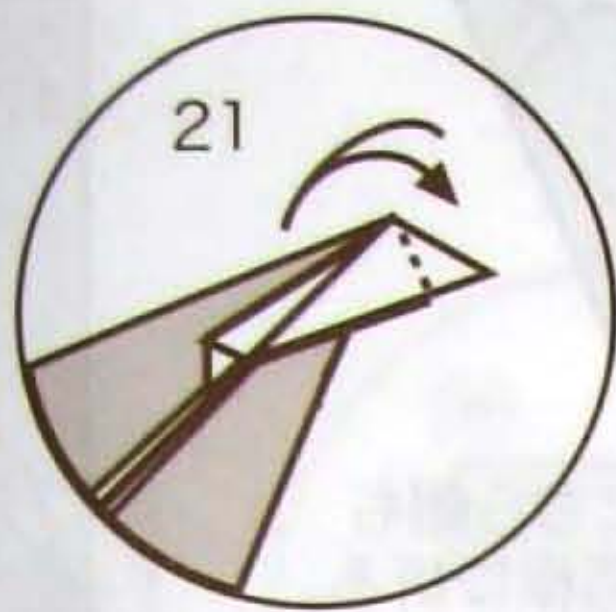
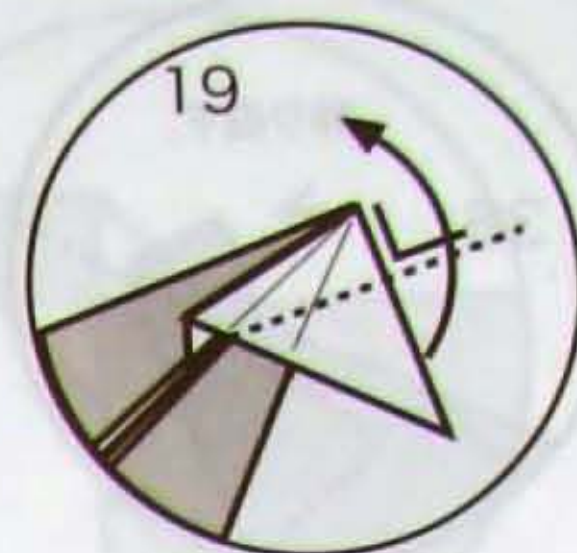
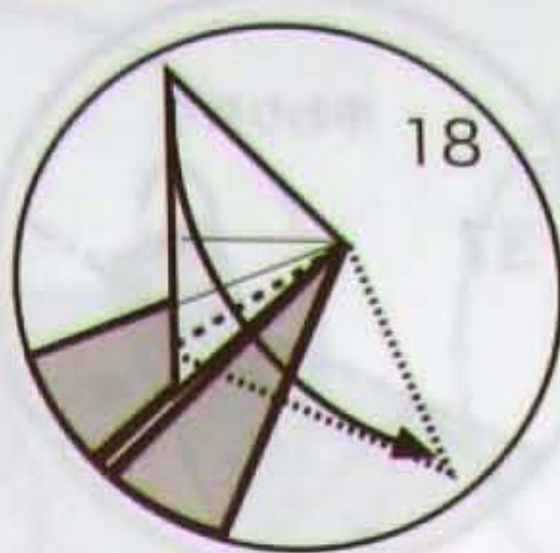
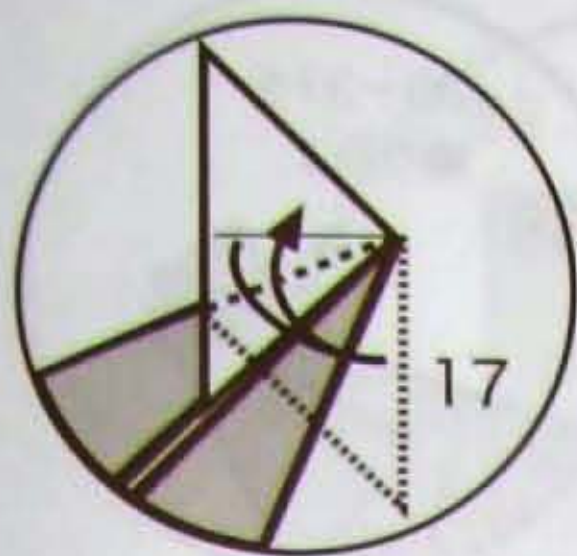

中わり折り

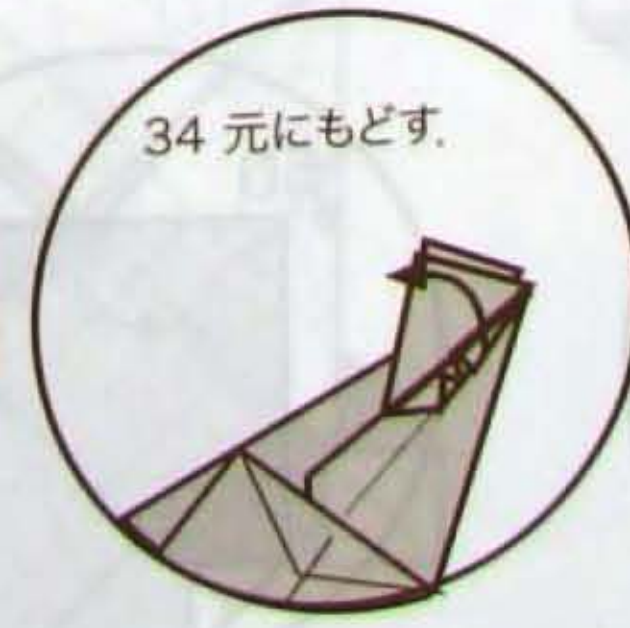
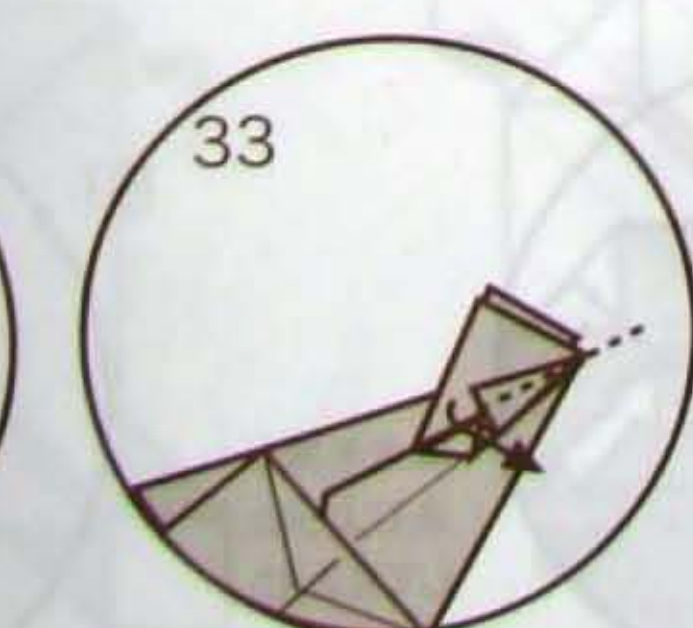
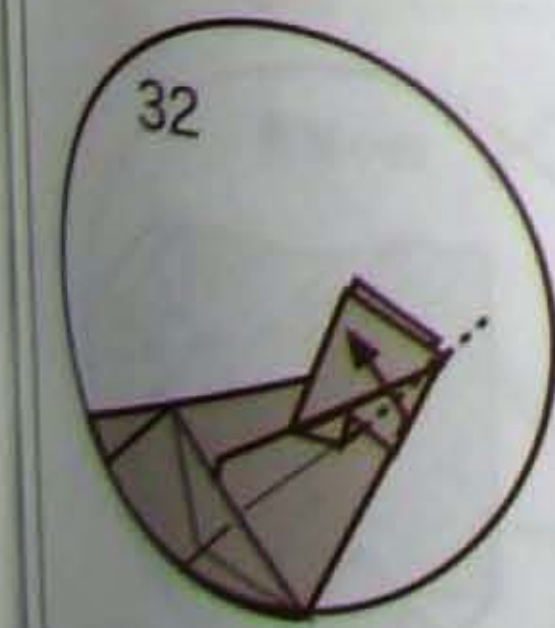
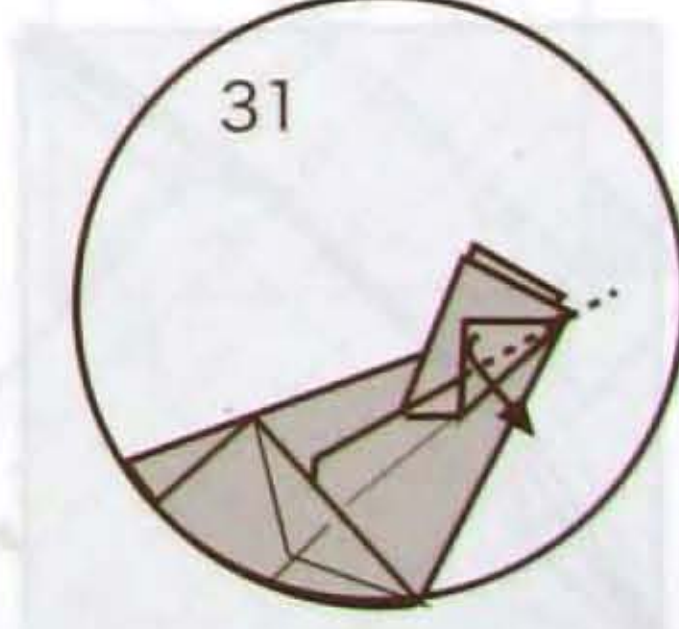
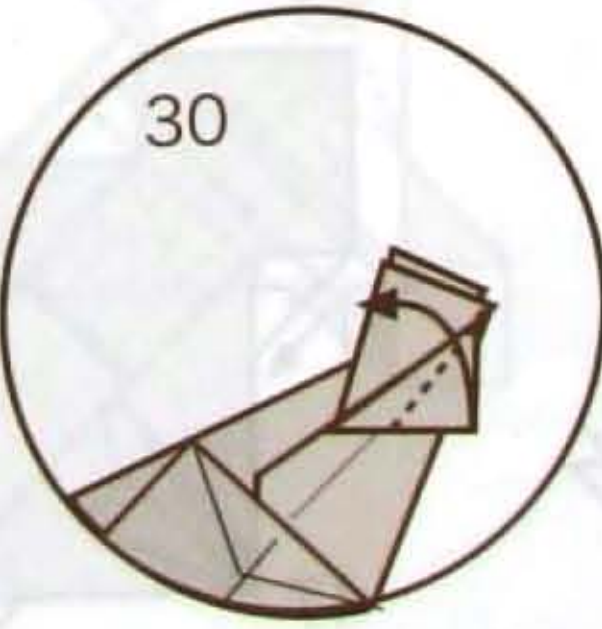
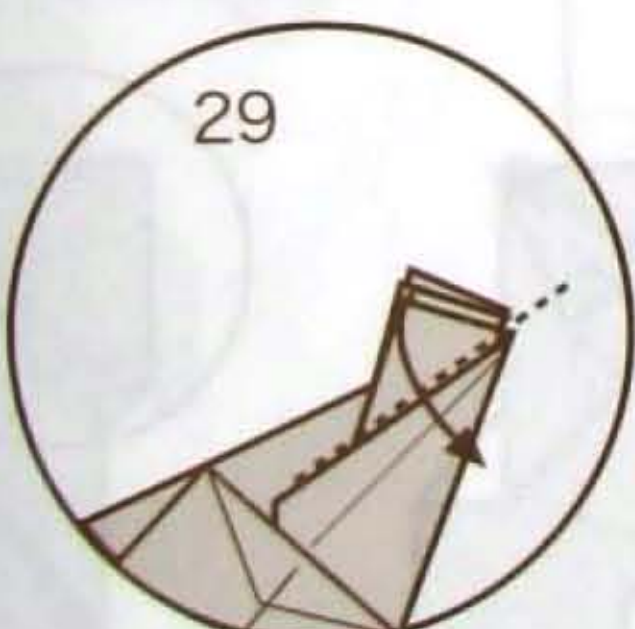
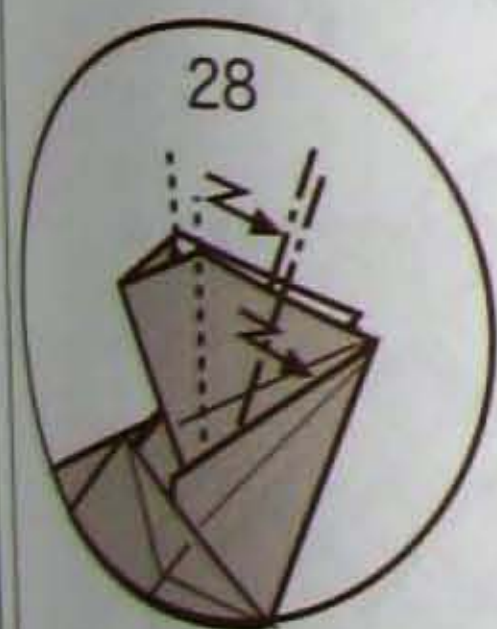
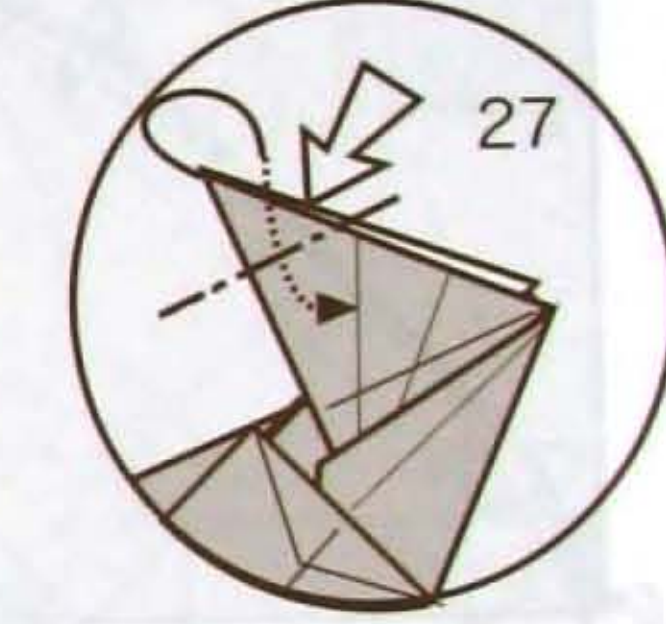
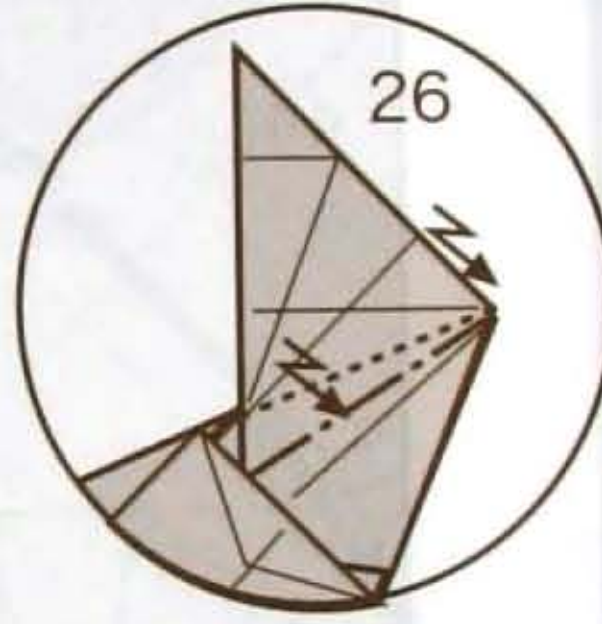
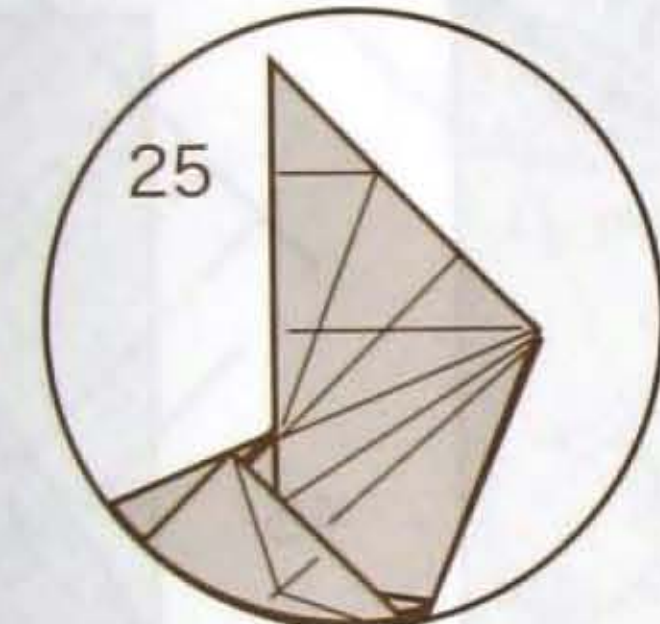
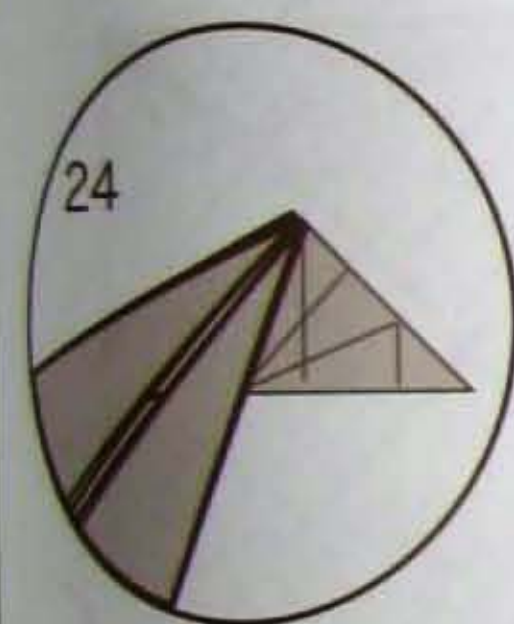

上がった三角
に倒す。

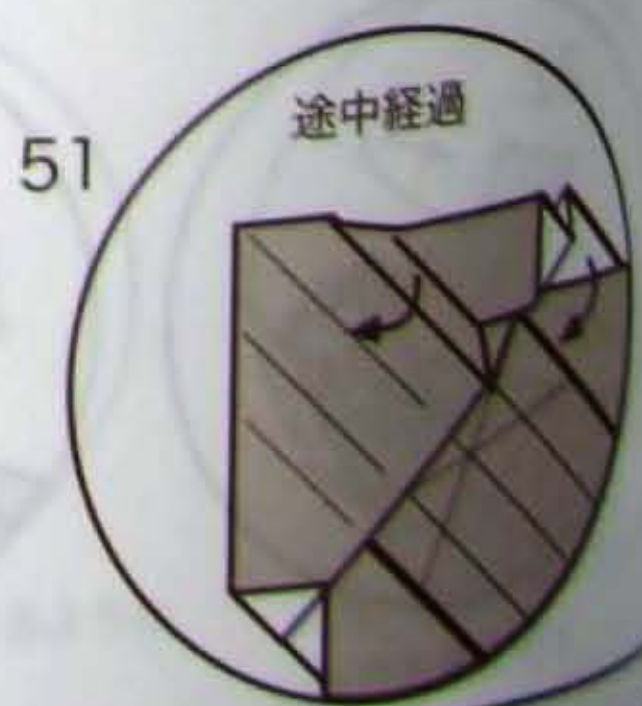
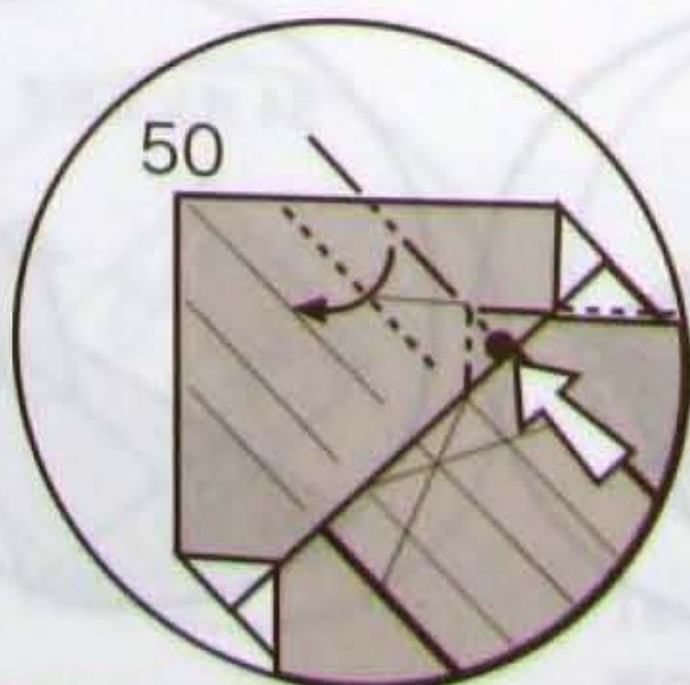
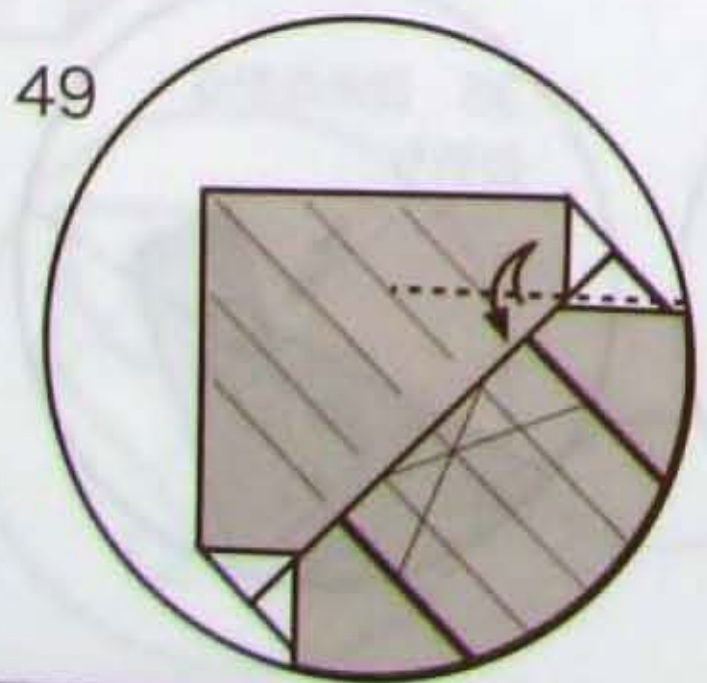
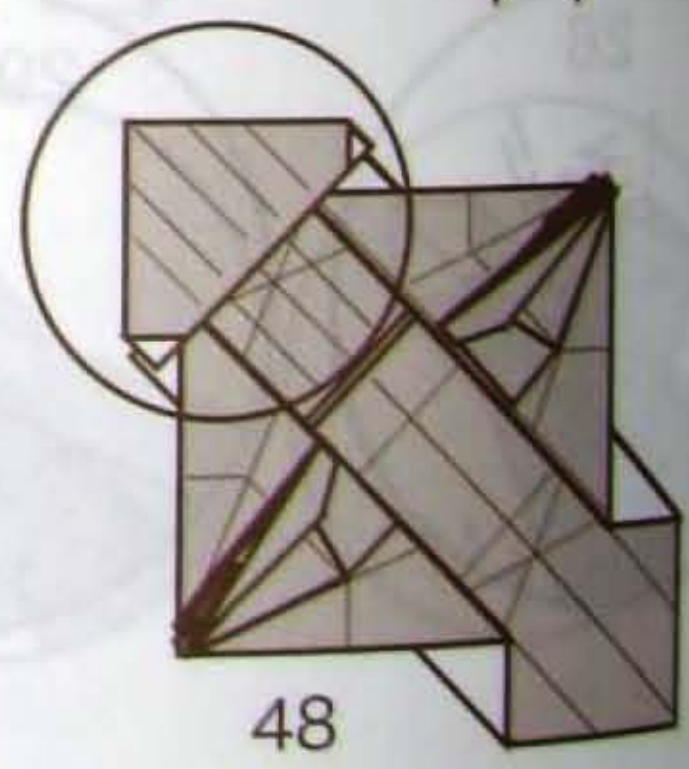
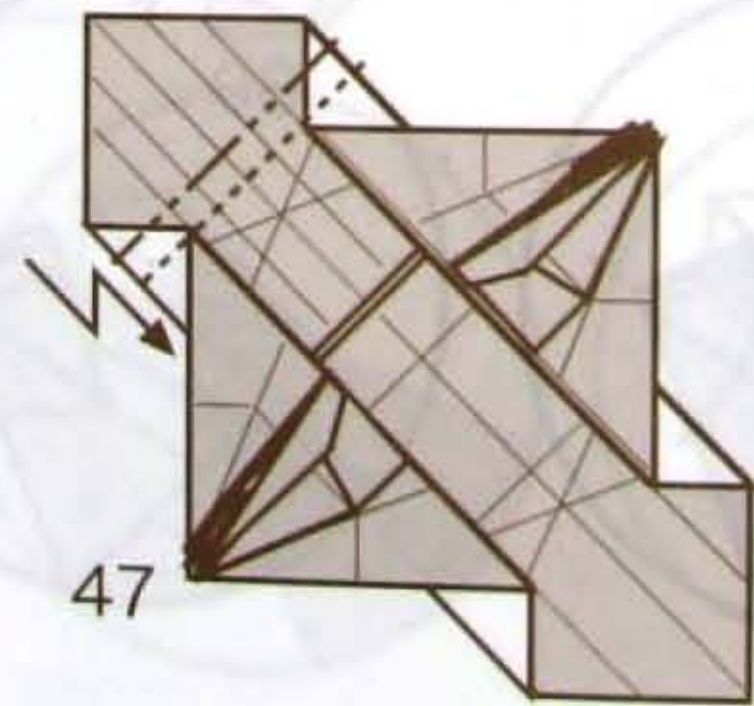
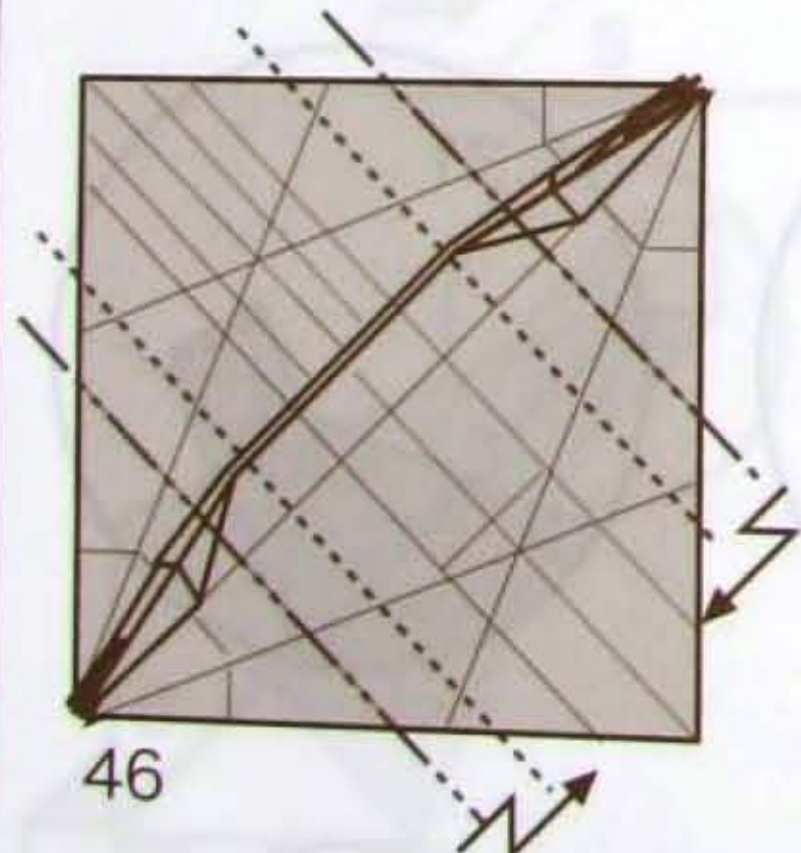
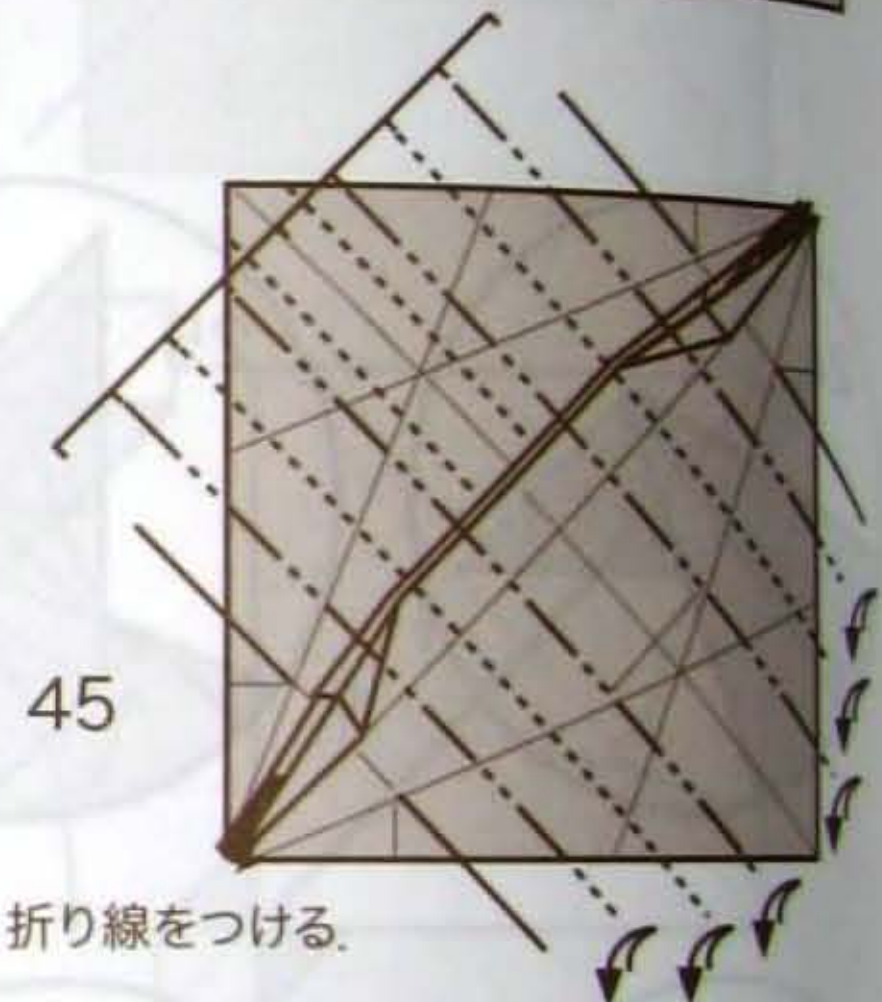
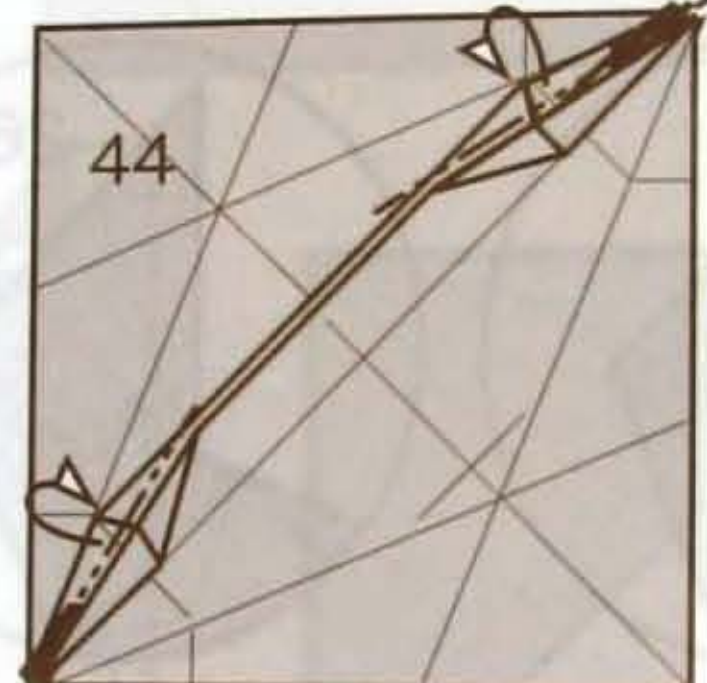
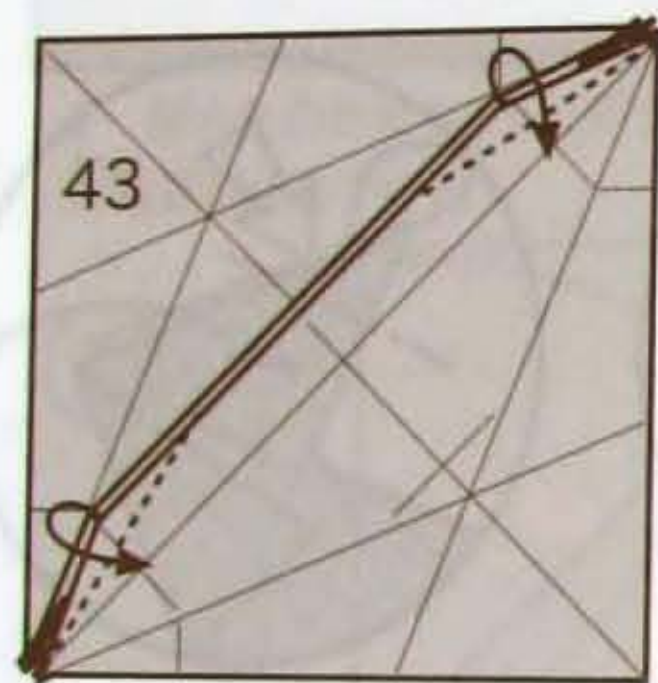
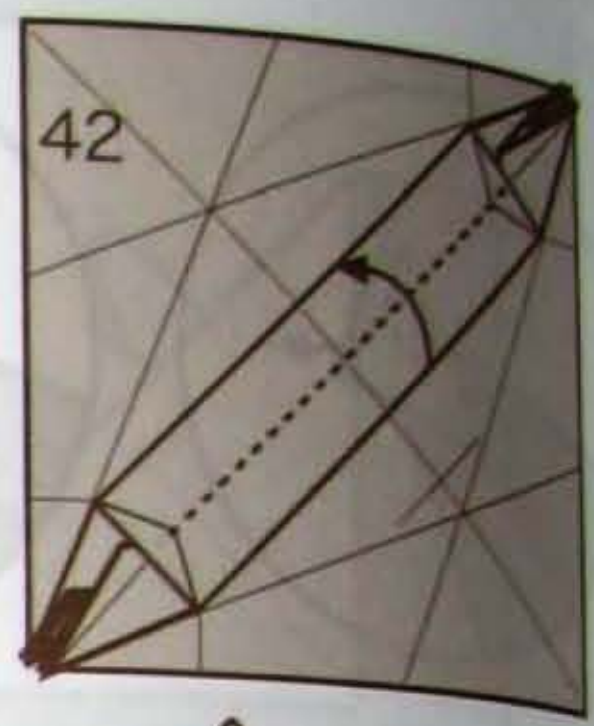
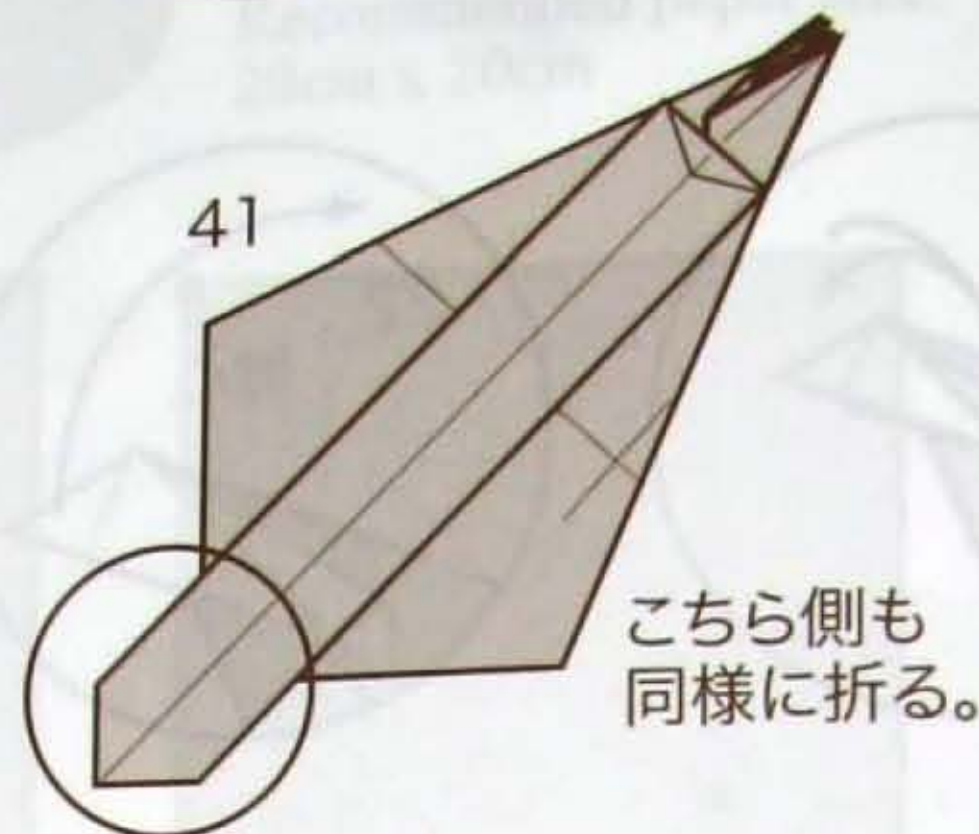
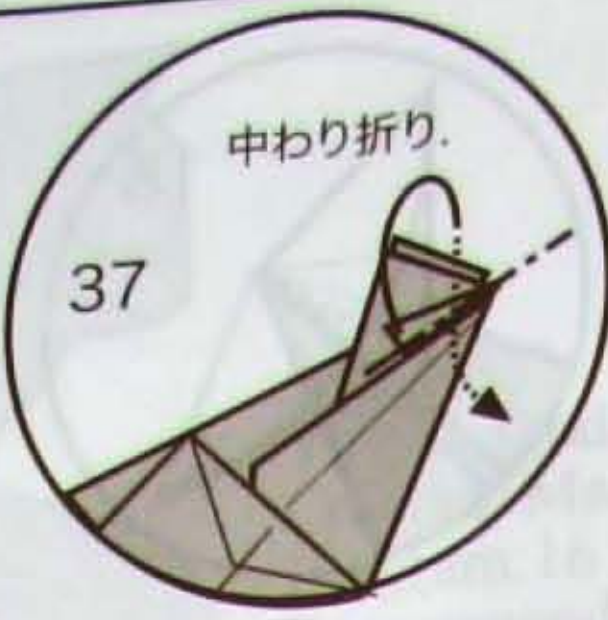
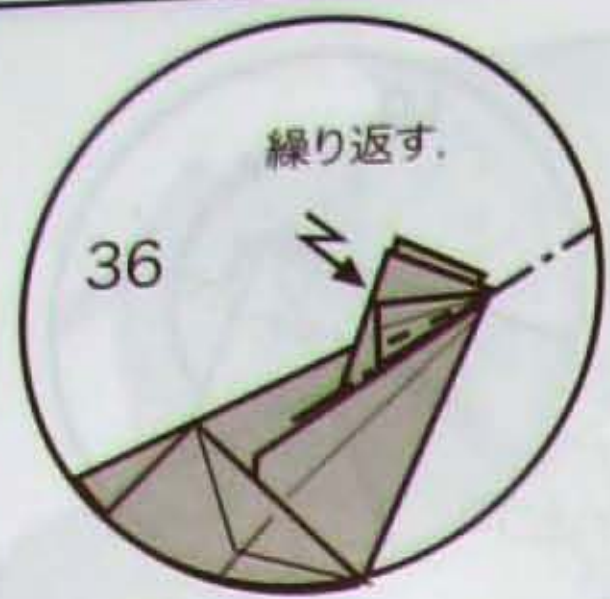

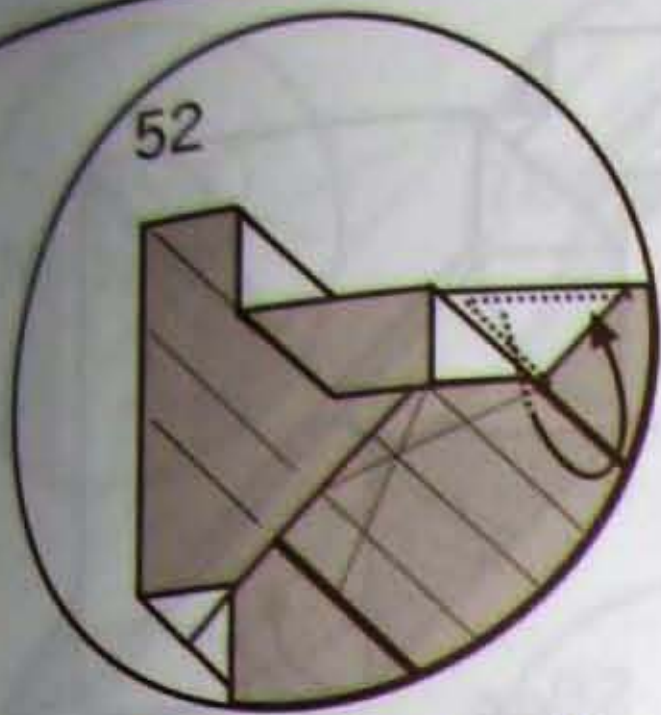

下の三角部分を手前に引き出し、紙の裏面を裏返すように折りたたむ。

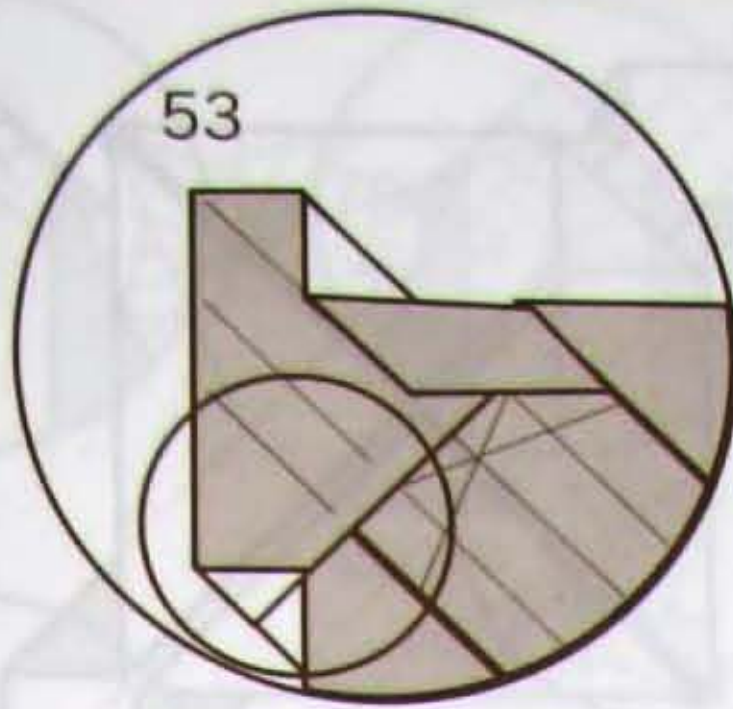

反対側も同様に折る。

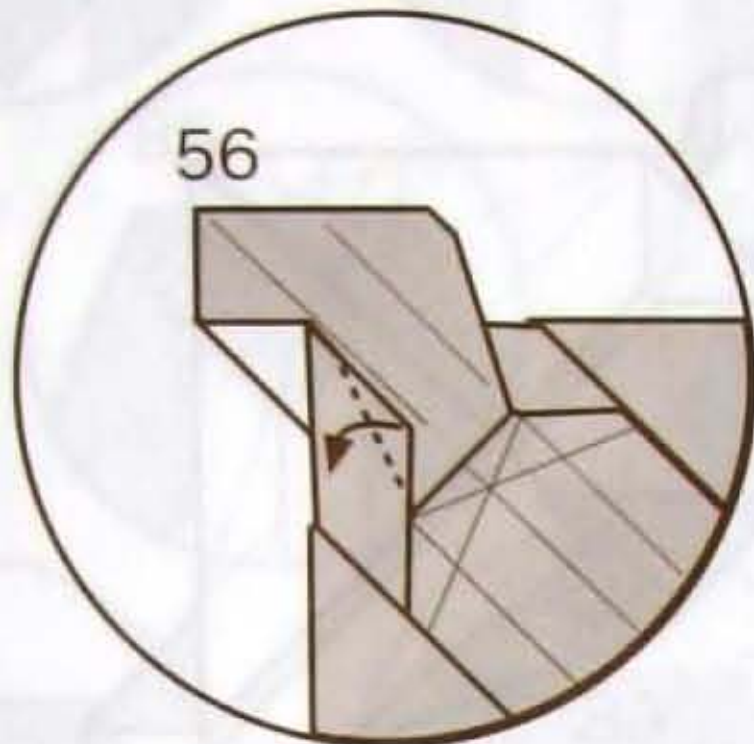
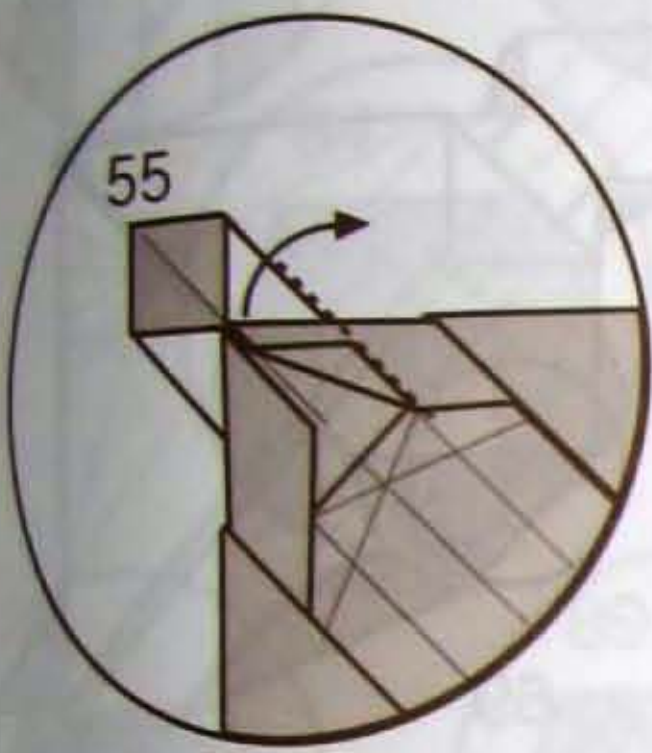
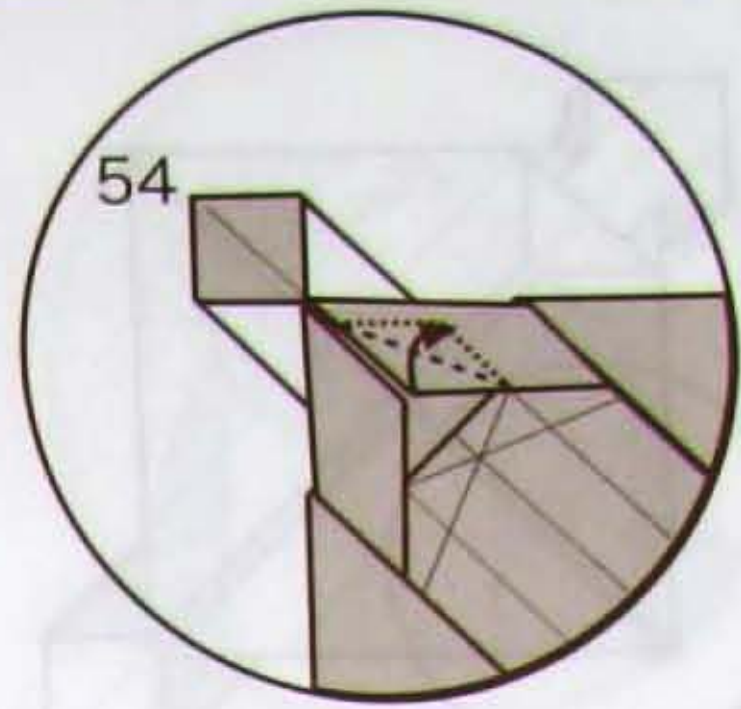

反対側も同様

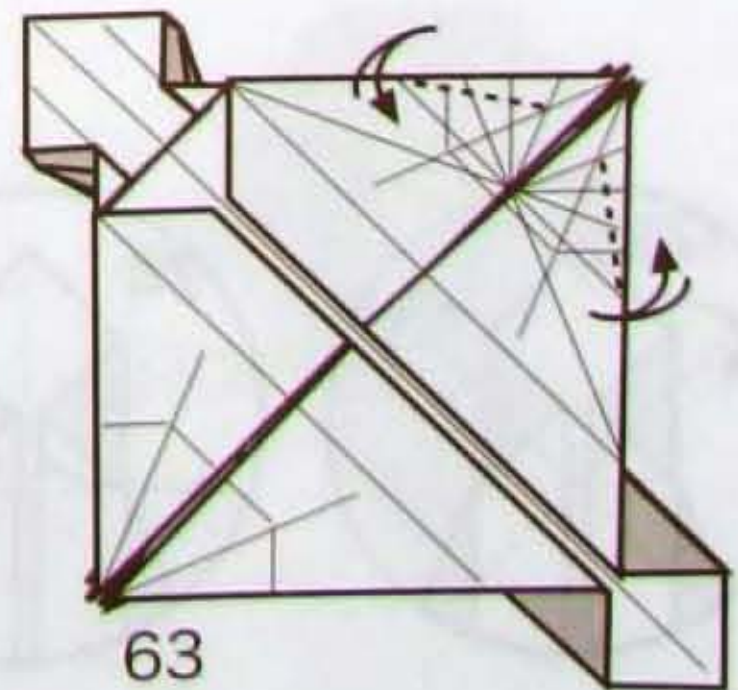
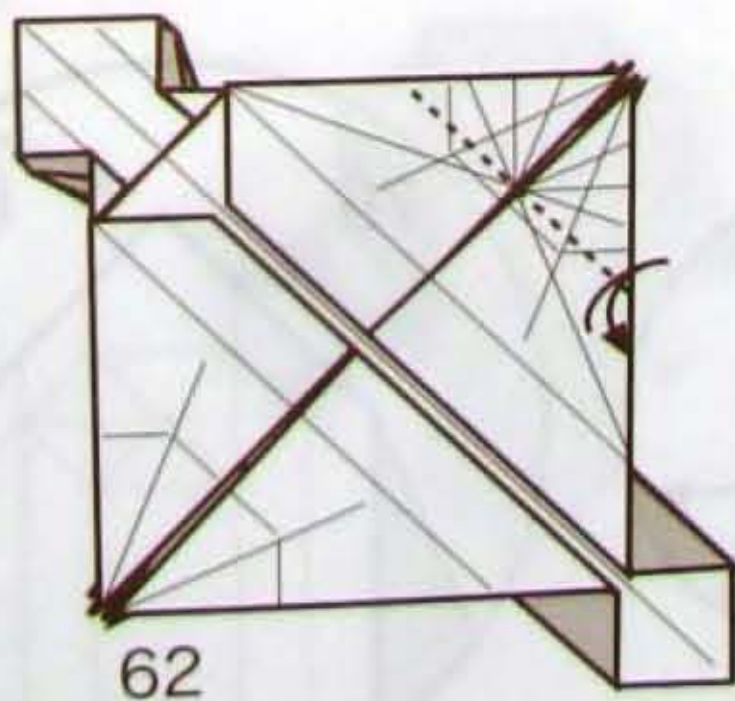
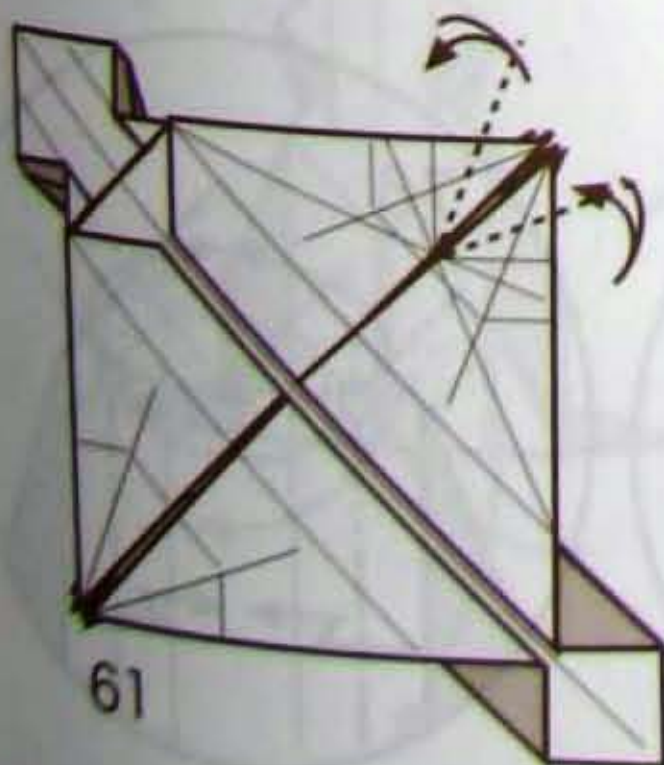
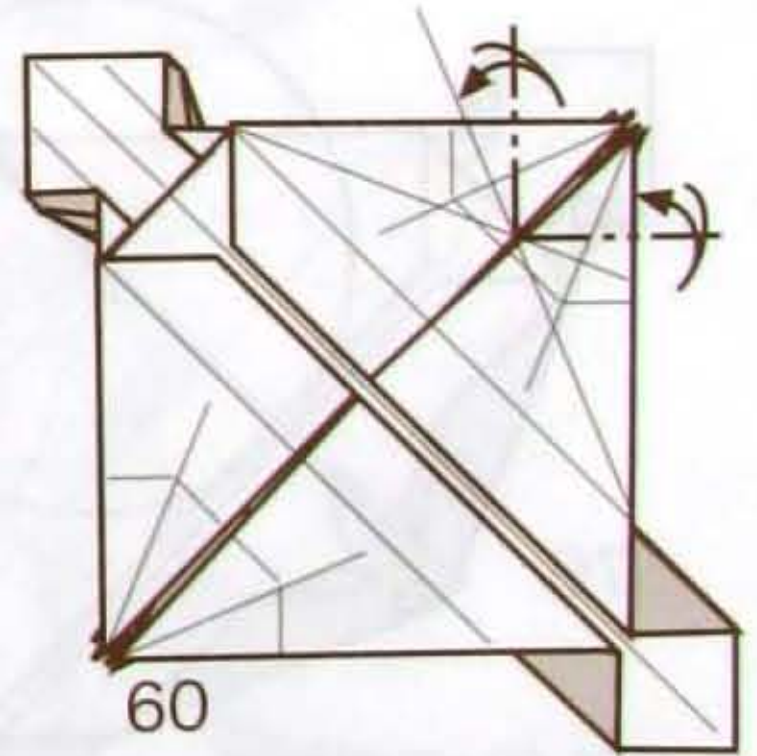
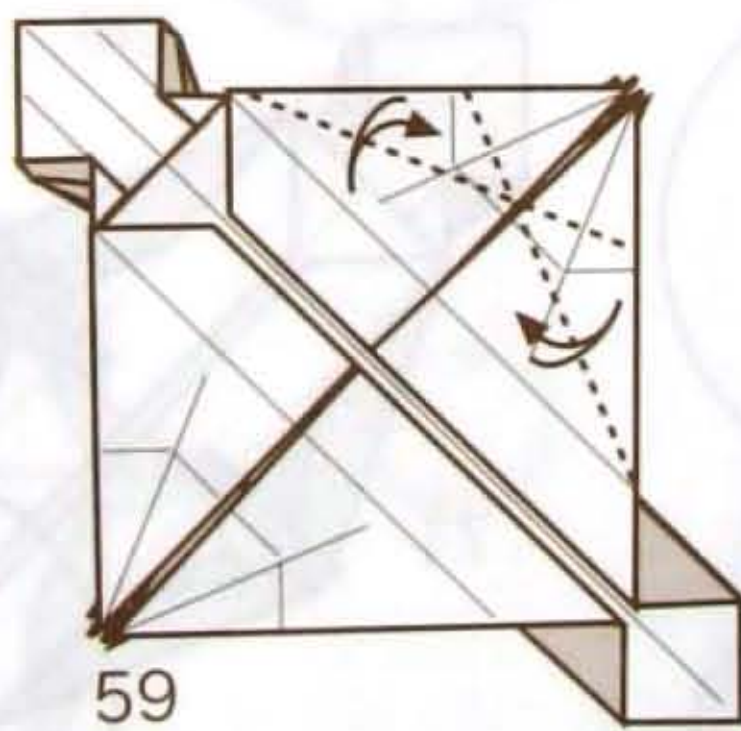
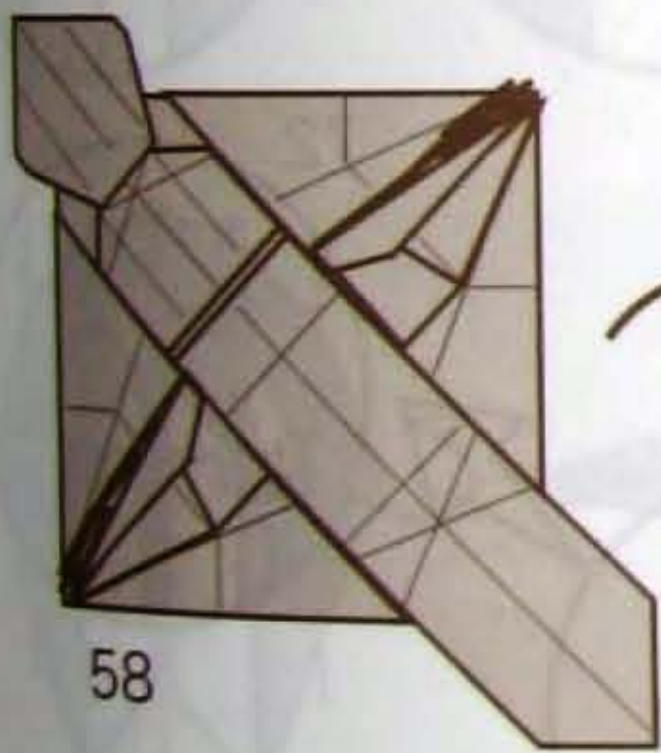
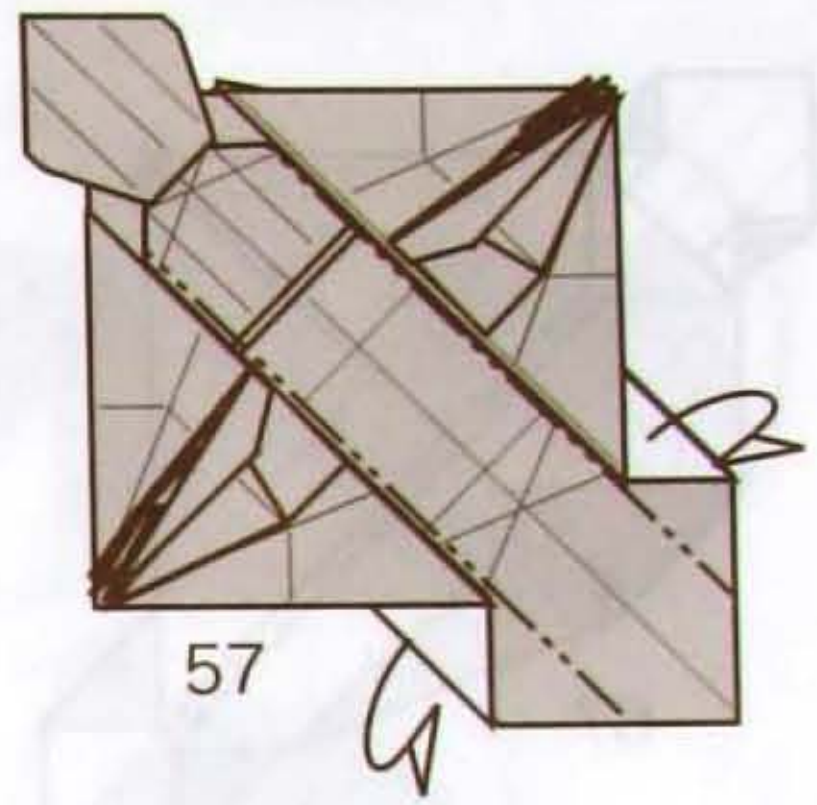

64

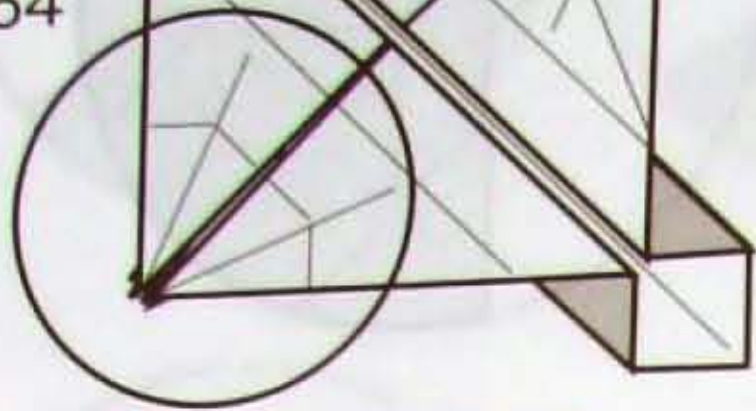

こちら側も59-63と同様に折る。

65

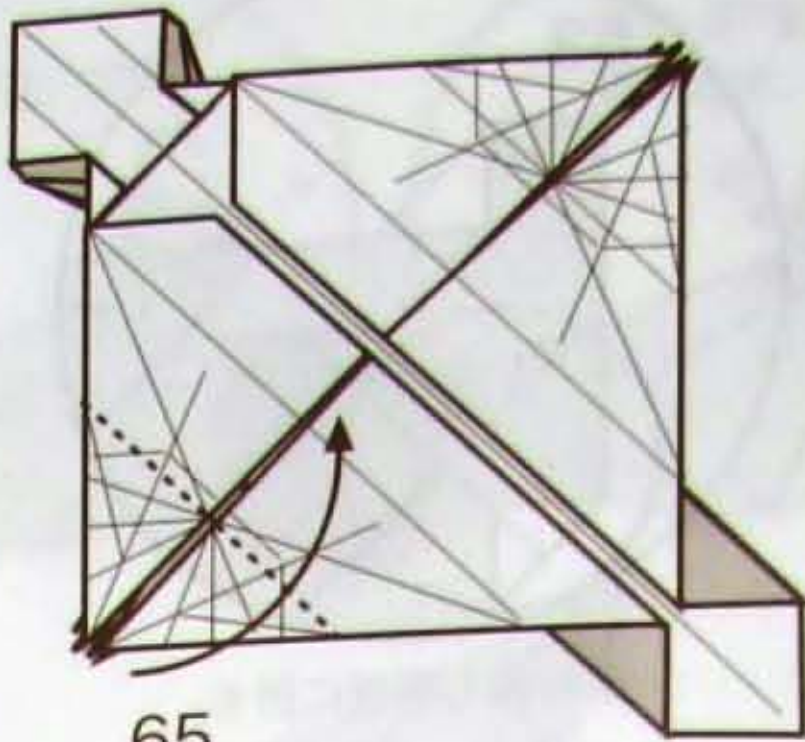

66

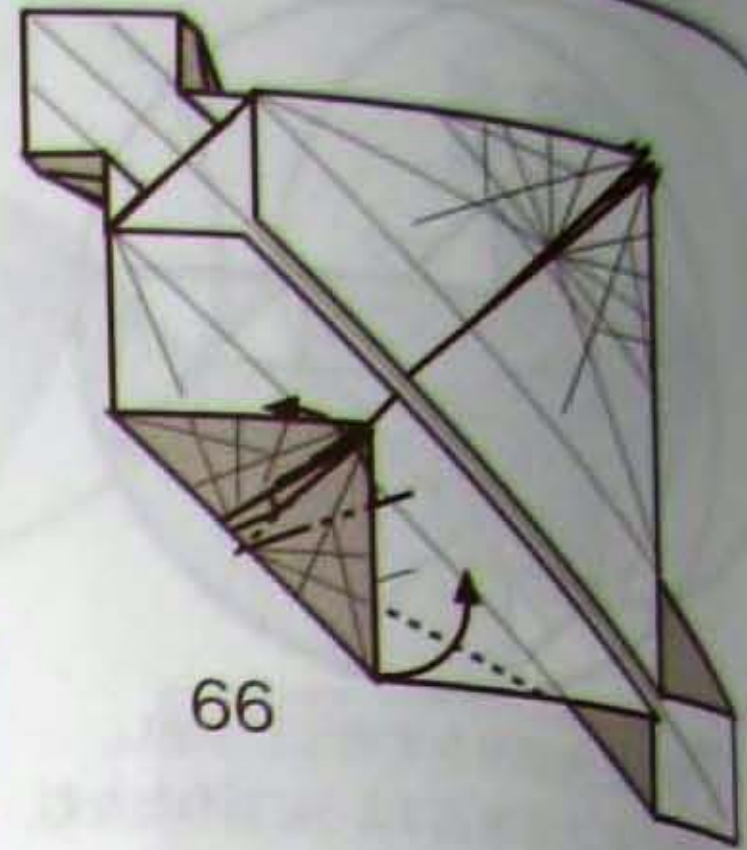

67

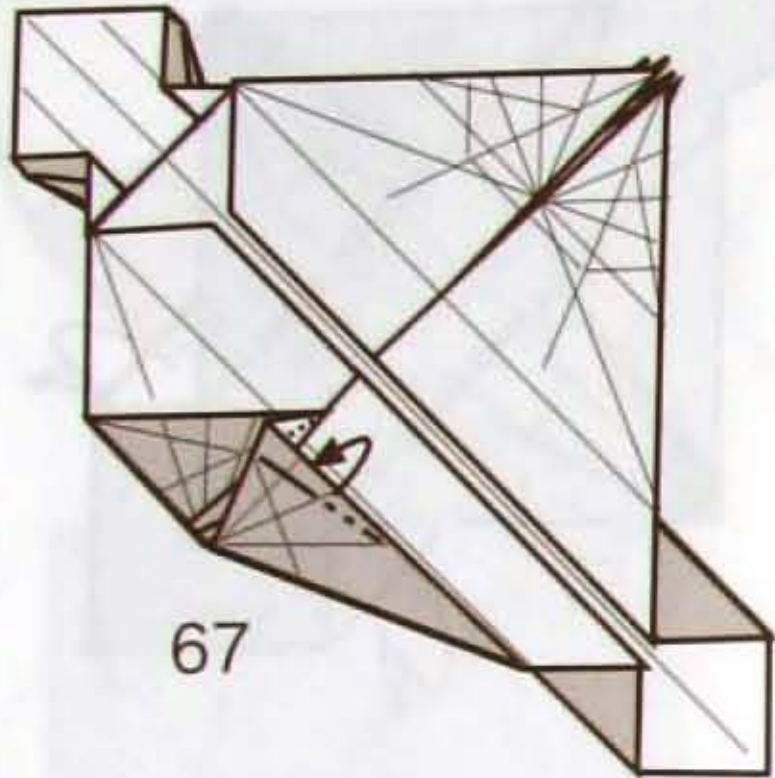

68

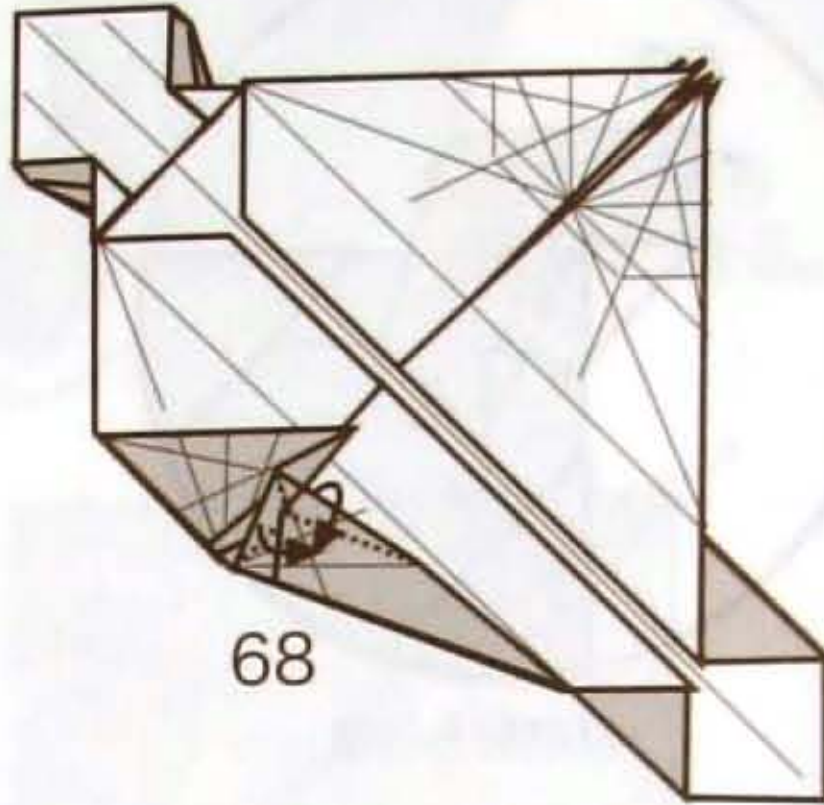

69

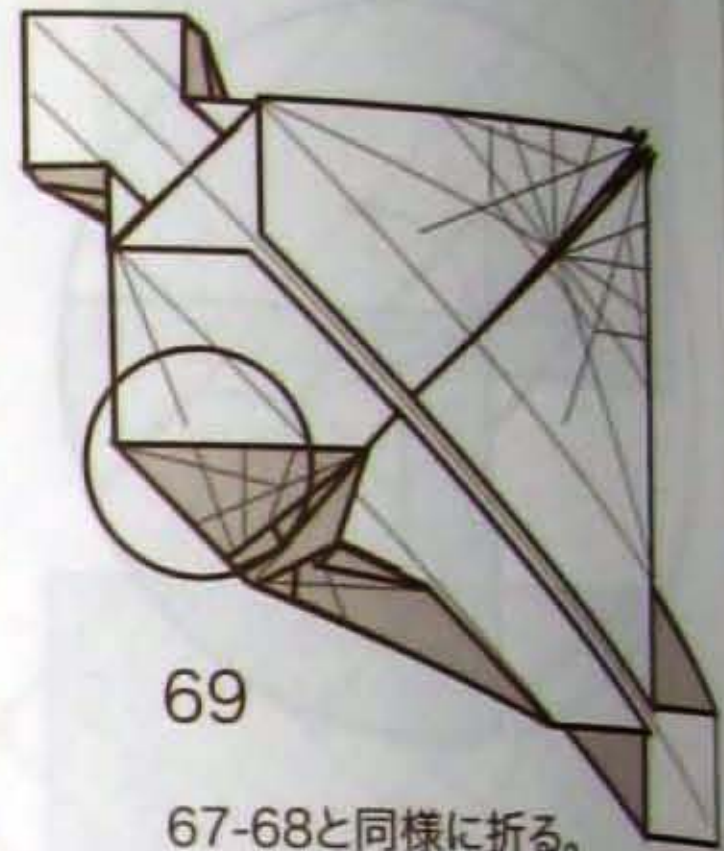

67-68と同様に折る。

70

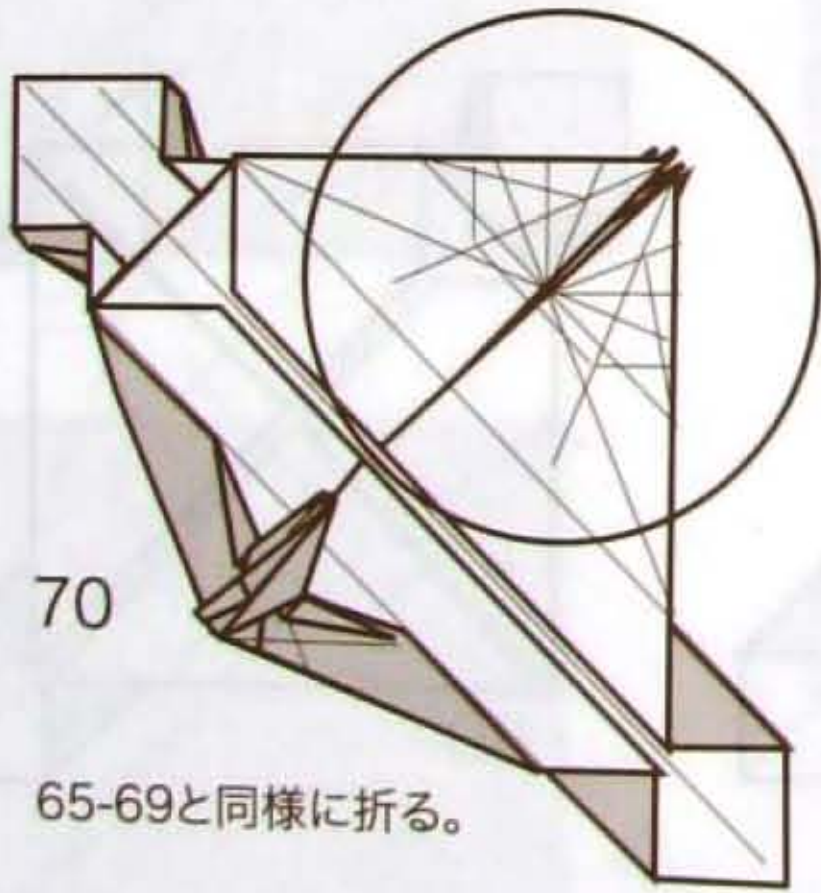

65-69と同様に折る。

71

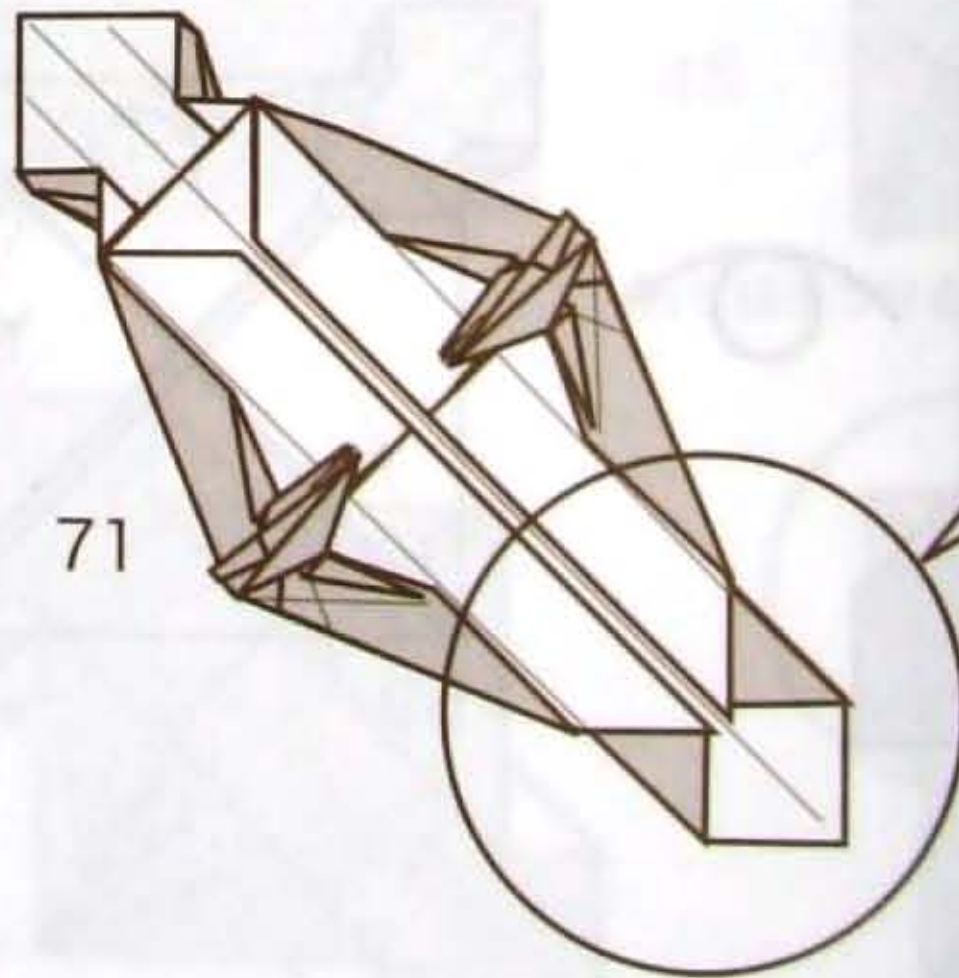

72

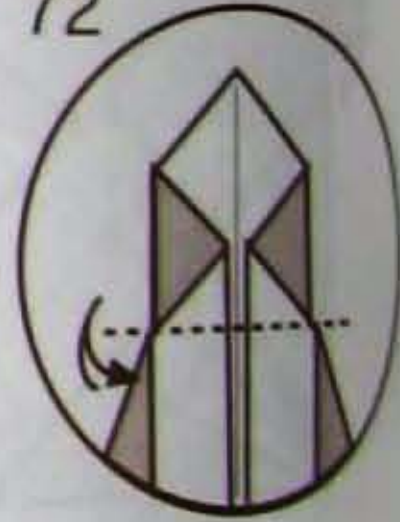

73

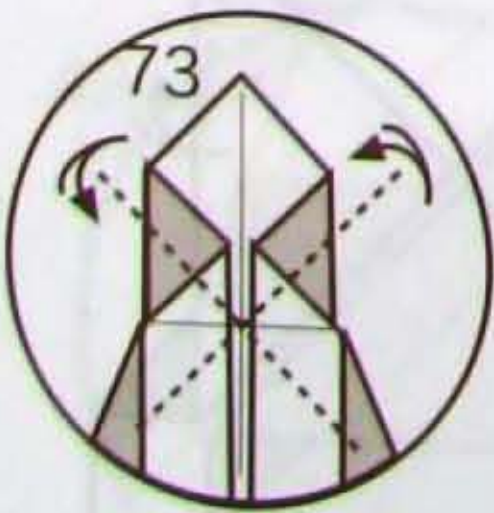

74

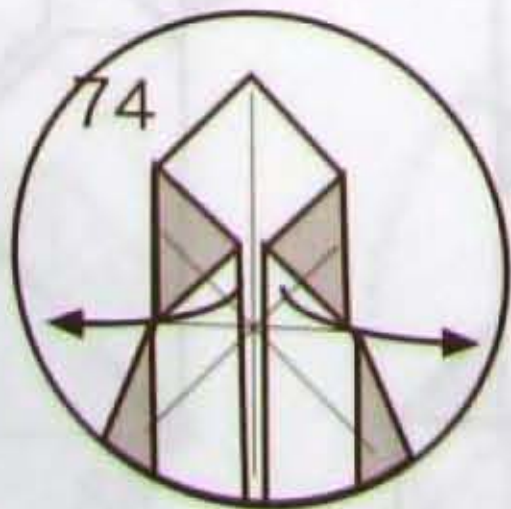

75

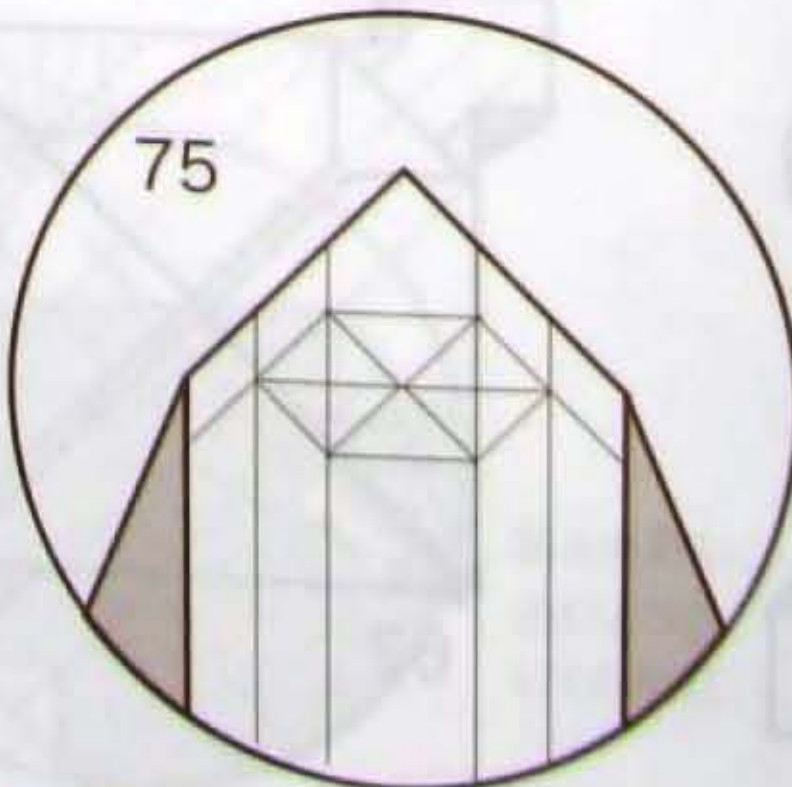

76

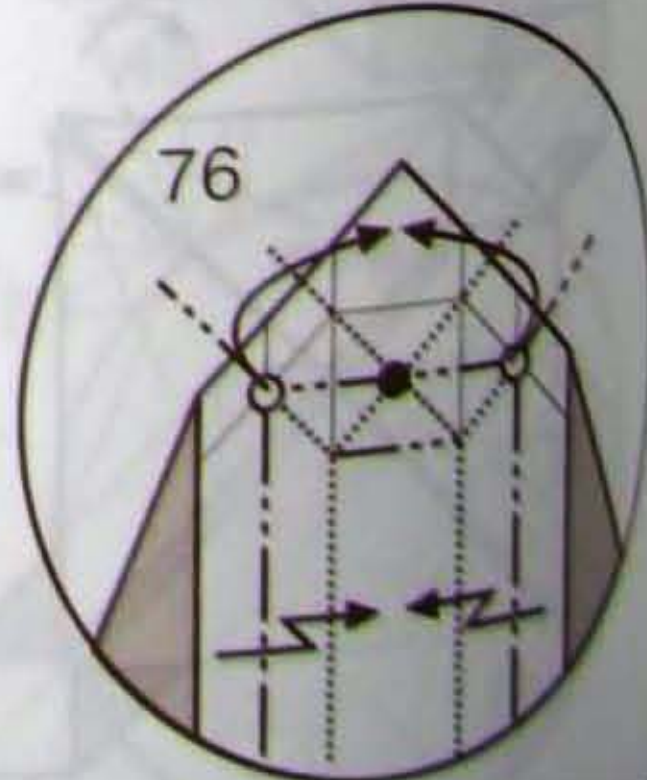

77

81

88

92

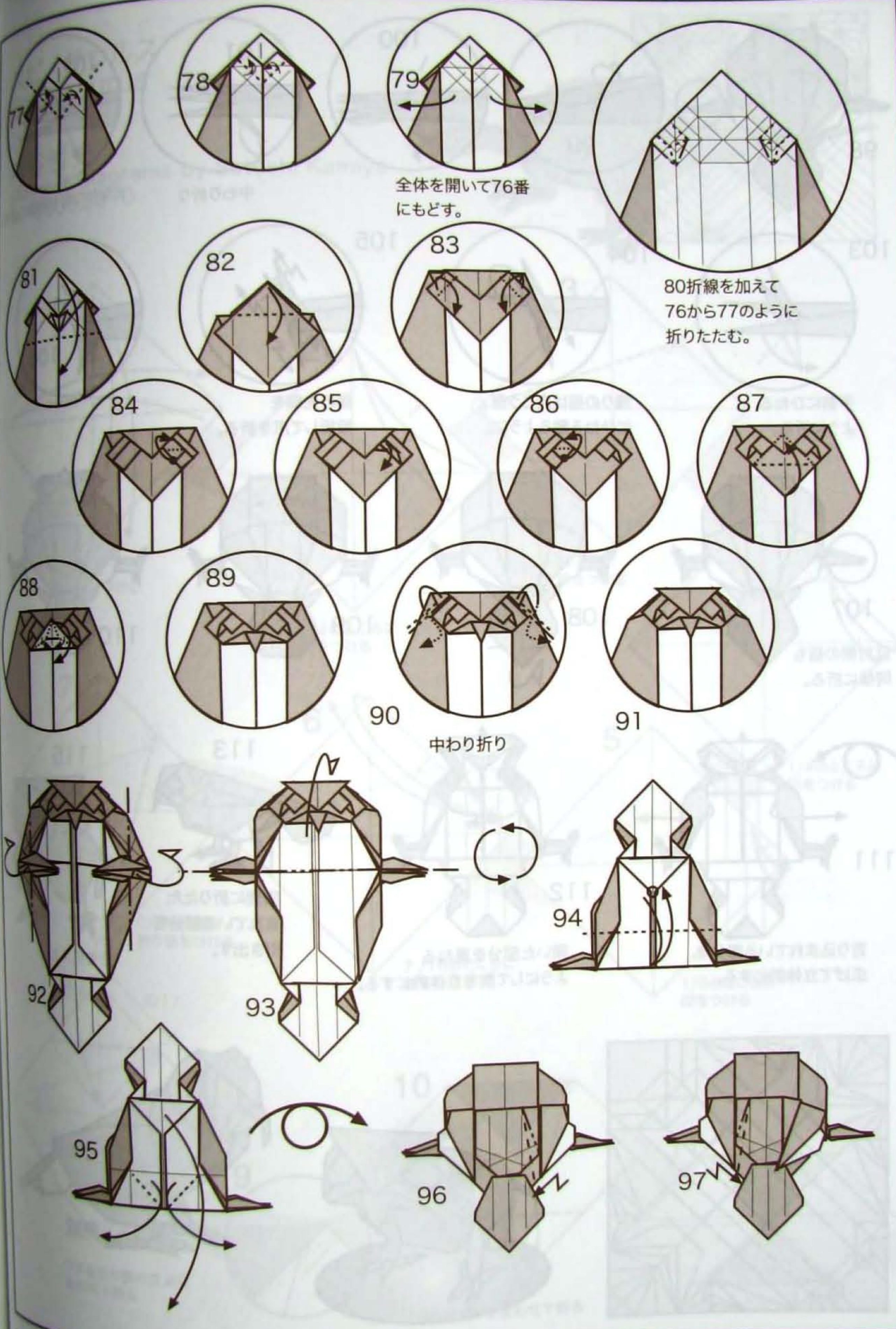

全体を開いて76番にもどす。

80折線を加えて76から77のように折りたたむ。

中わり折り

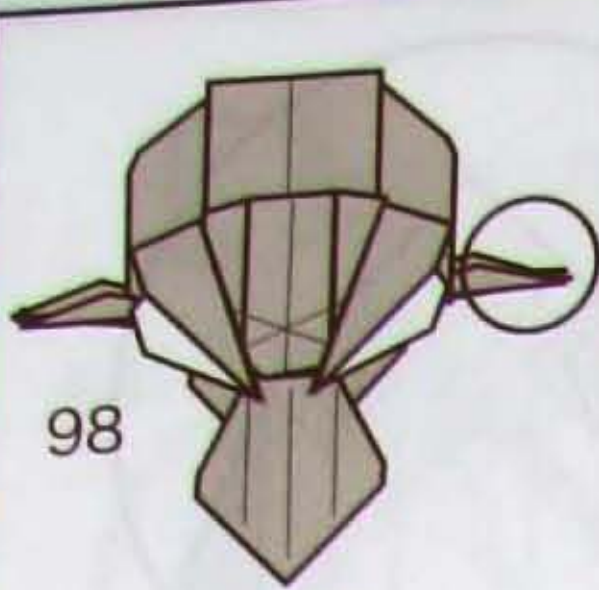

98



99

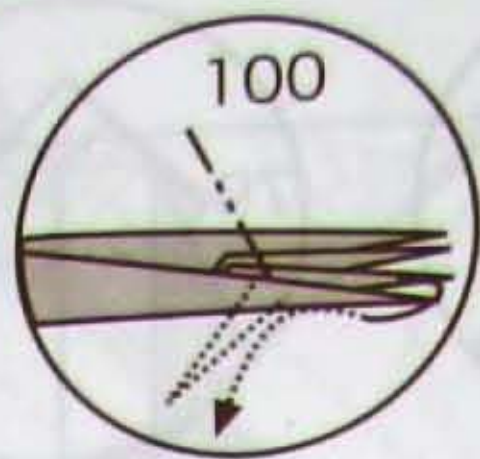

100



101

中わり折り



102

となりの指も同様に折る

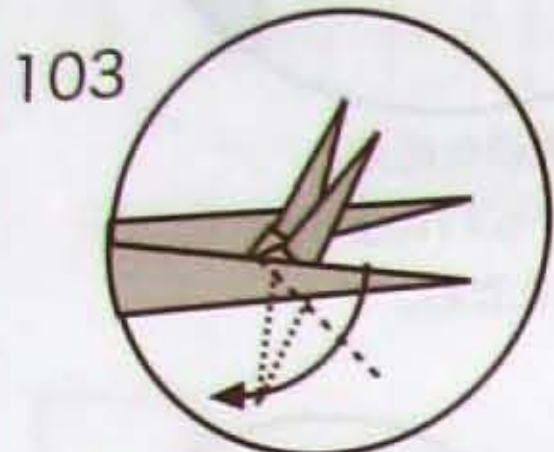

103

手前にひねる
ように折る。



104

残りの指は向こう側
にひねる載るように。

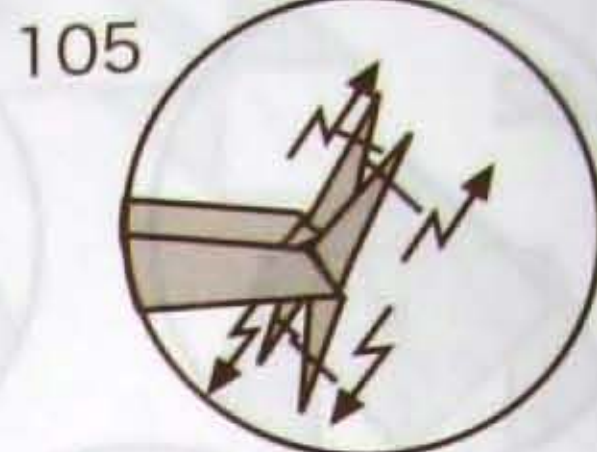

105

指の先端を
段折して爪を折る。



106

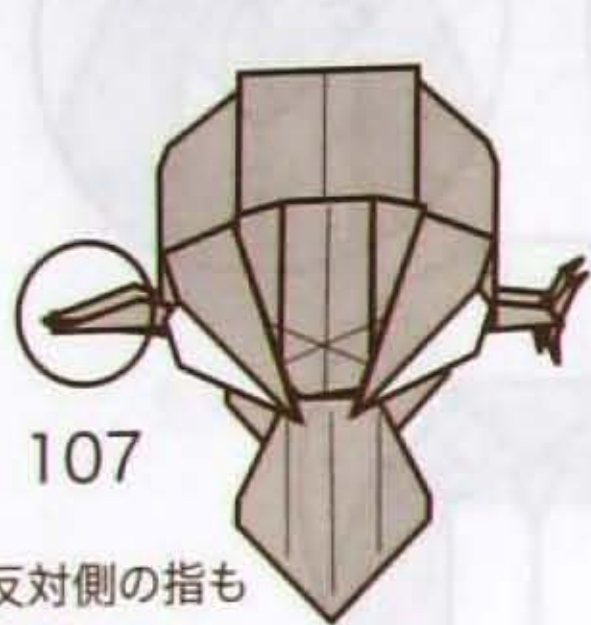

107

反対側の指も
同様に折る。

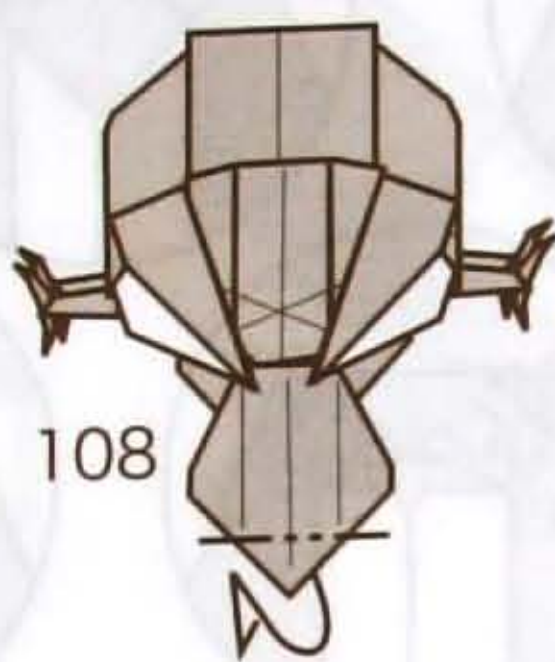

108

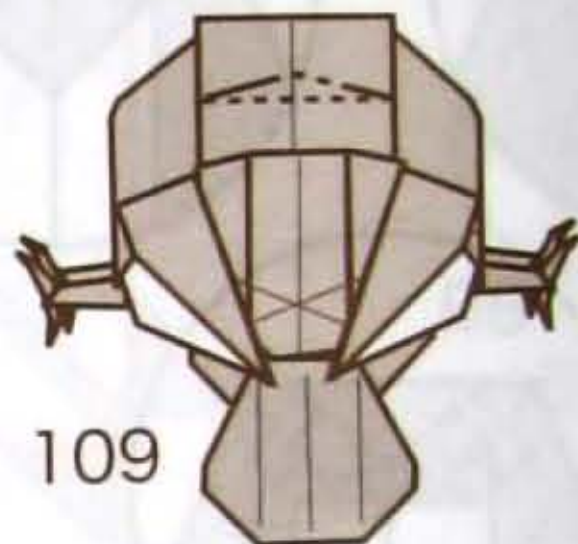

109



110

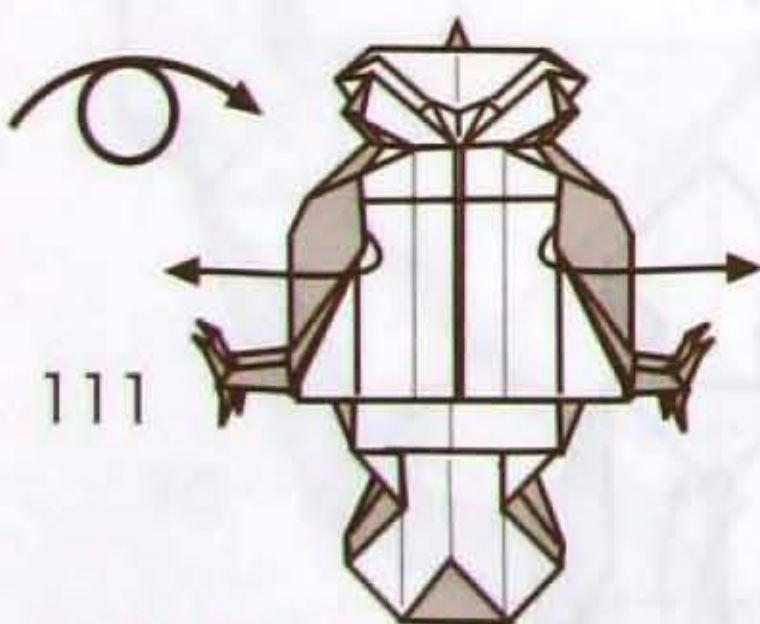

111

折り込まれている部分を
広げて立体的にする。



112

開いた部分を重ねる
ようにして胸を立体的にする。

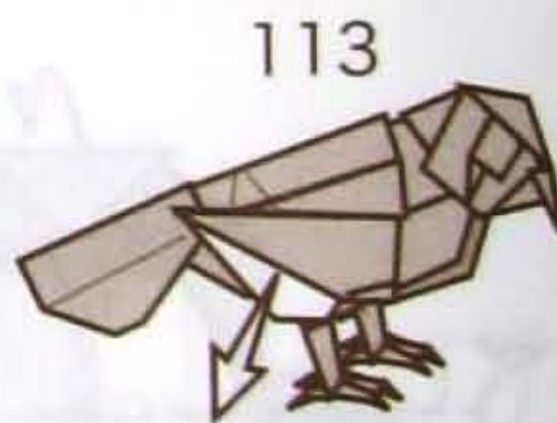

113

内側に折りた
まれている部分を
引き出す。



115

形を整える。

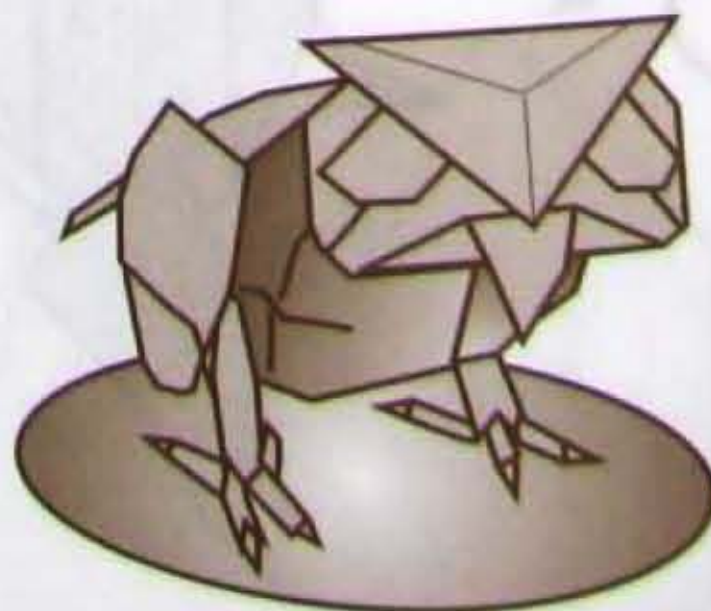
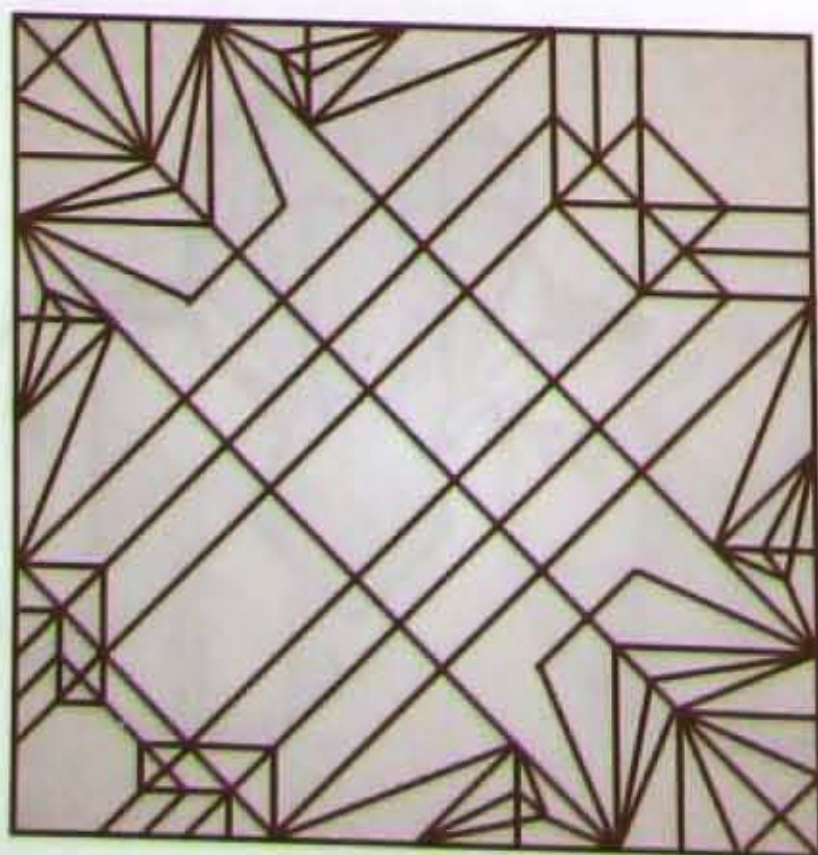

完成

スピノサウルス Spinosaurus

神谷哲史
Model & Diagrams by Satoshi Kamiya
作 2005, 2010

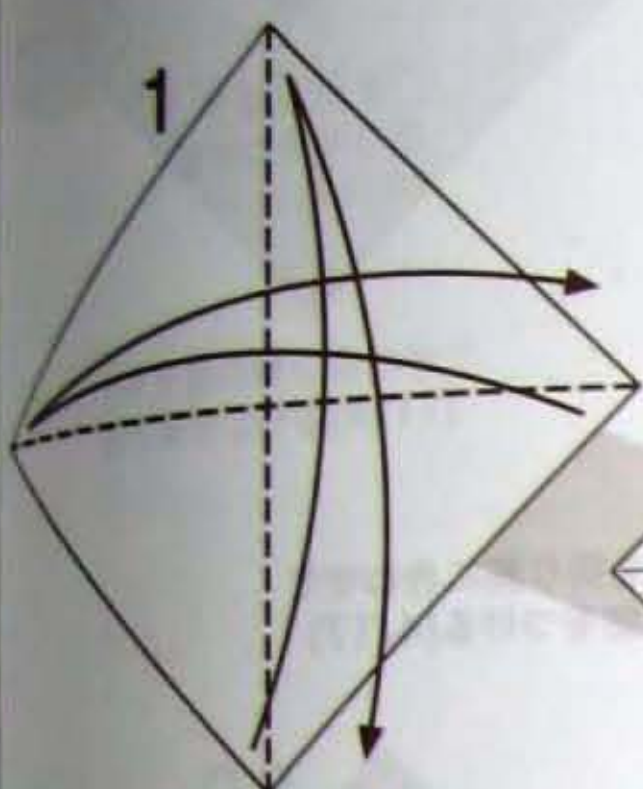
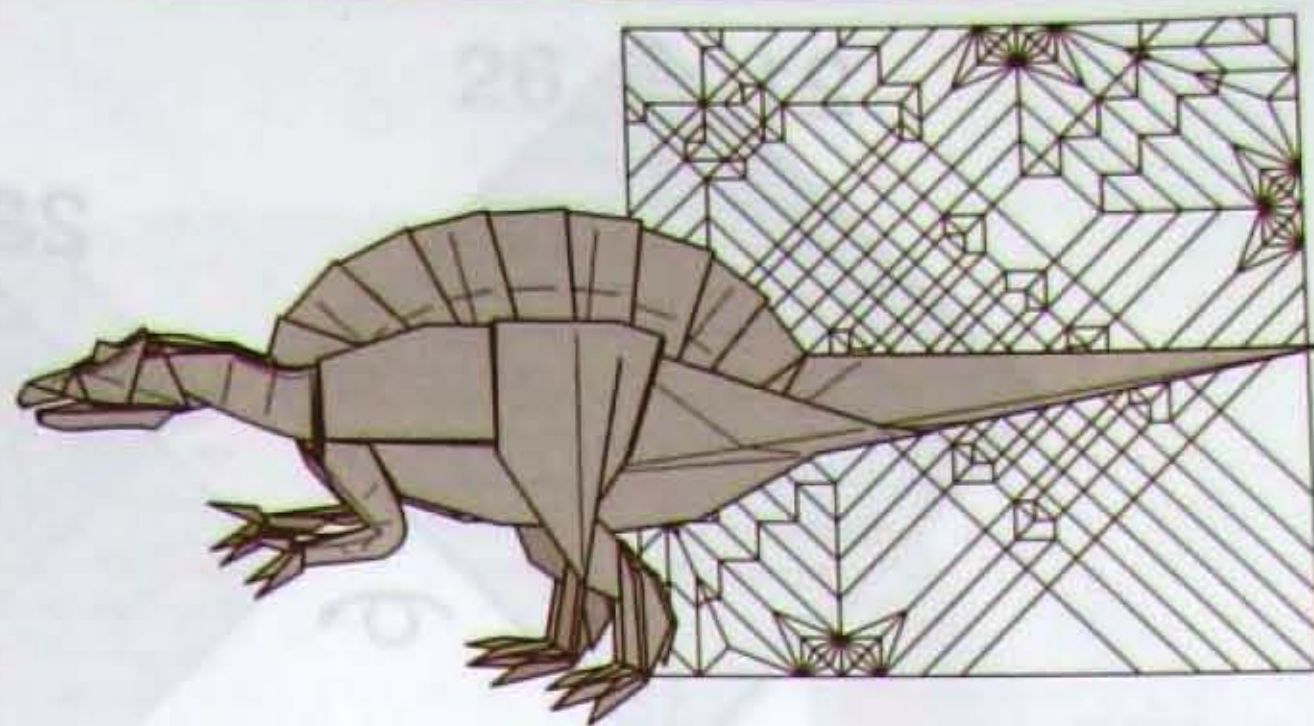

1
対角線に
折り筋をつける

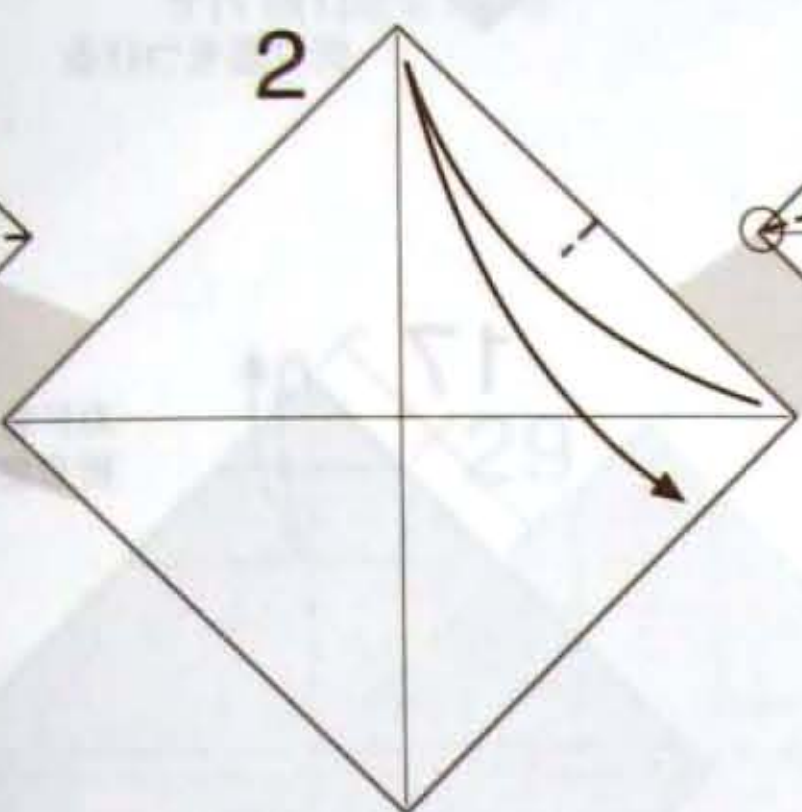

2
1/2のところに
印をつける

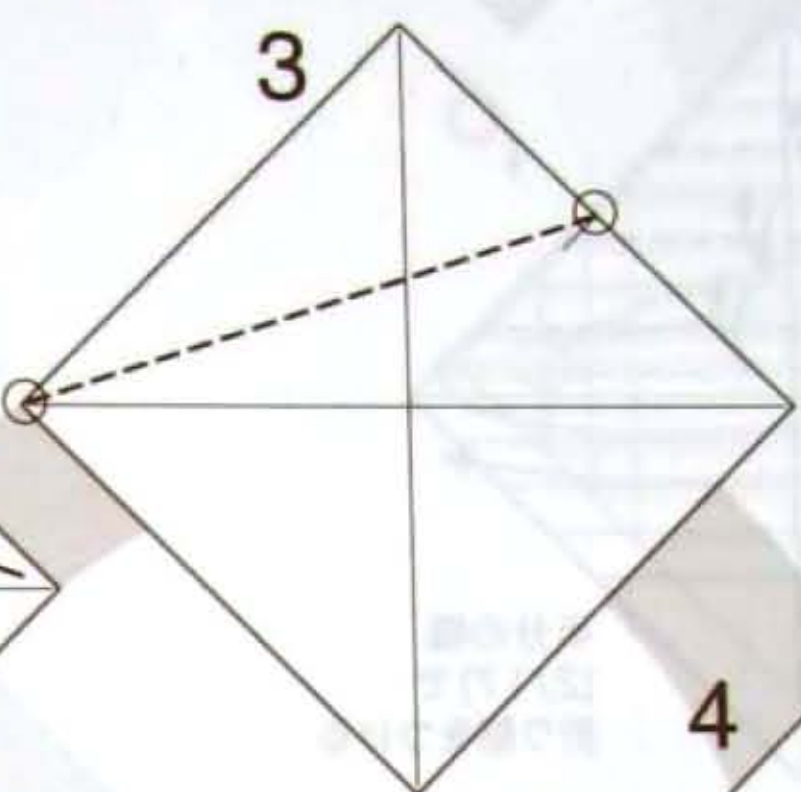

3
○を結ぶ線で
折り筋をつける

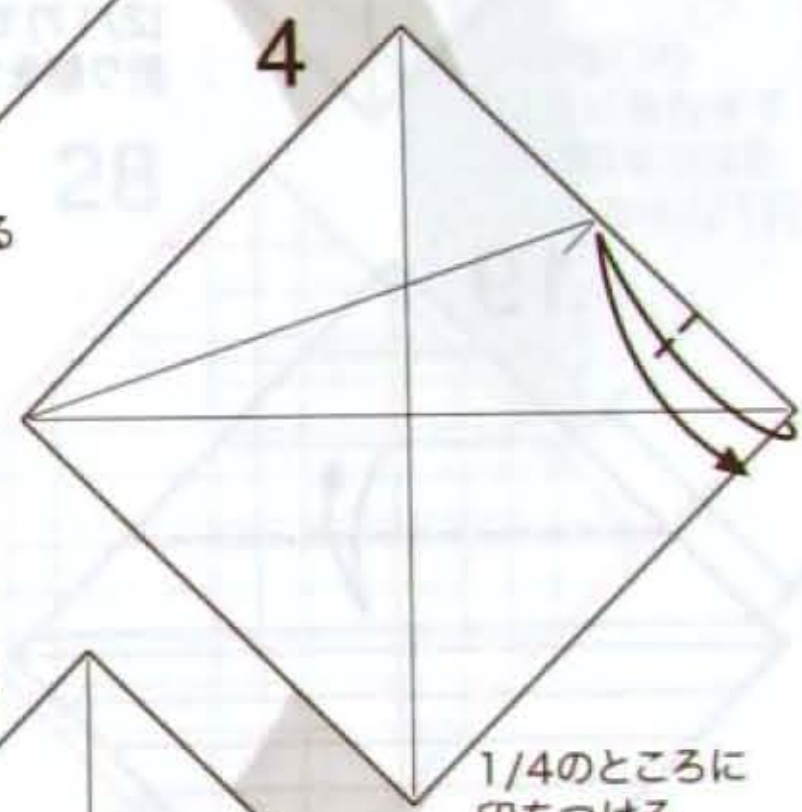

4
1/4のところに
印をつける

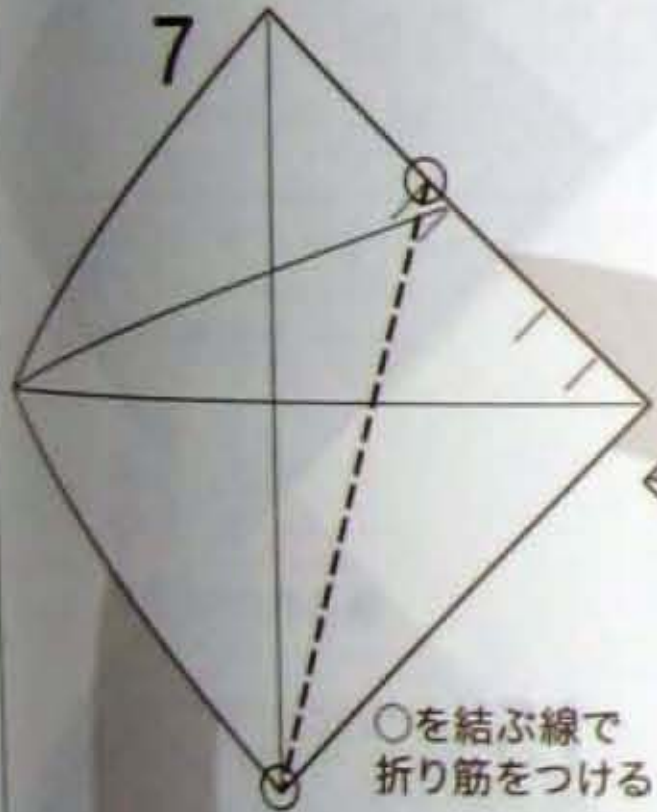

5
○を結ぶ線で
折り筋をつける

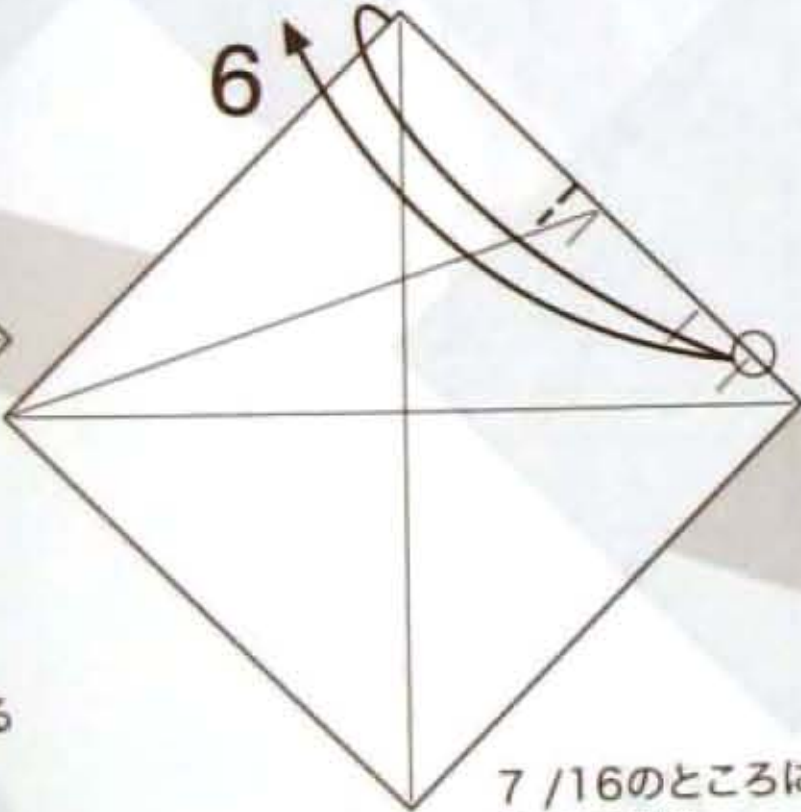

6
7/16のところに
印をつける

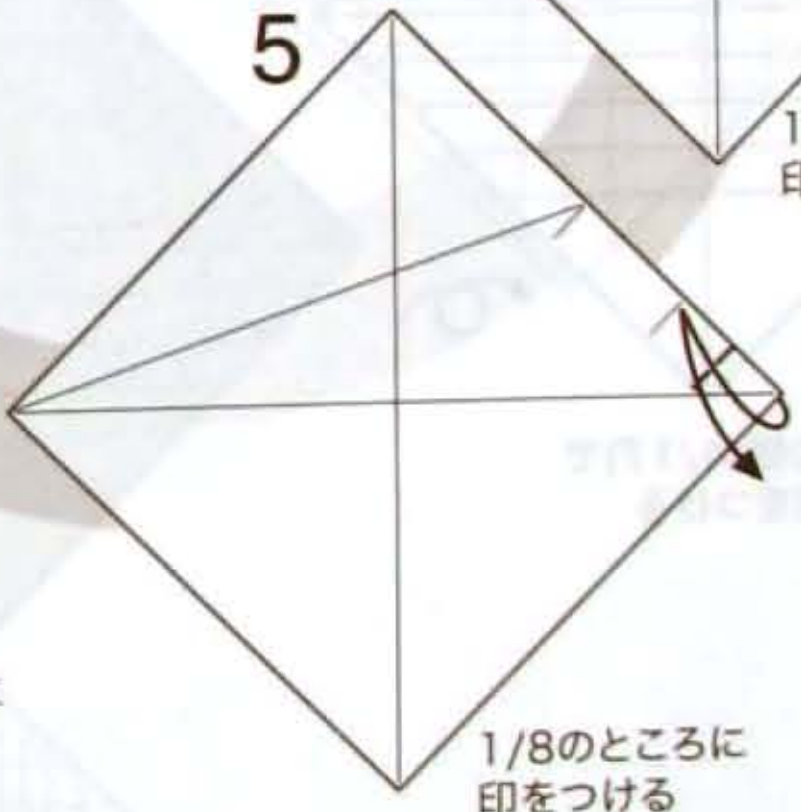

7
1/8のところに
印をつける

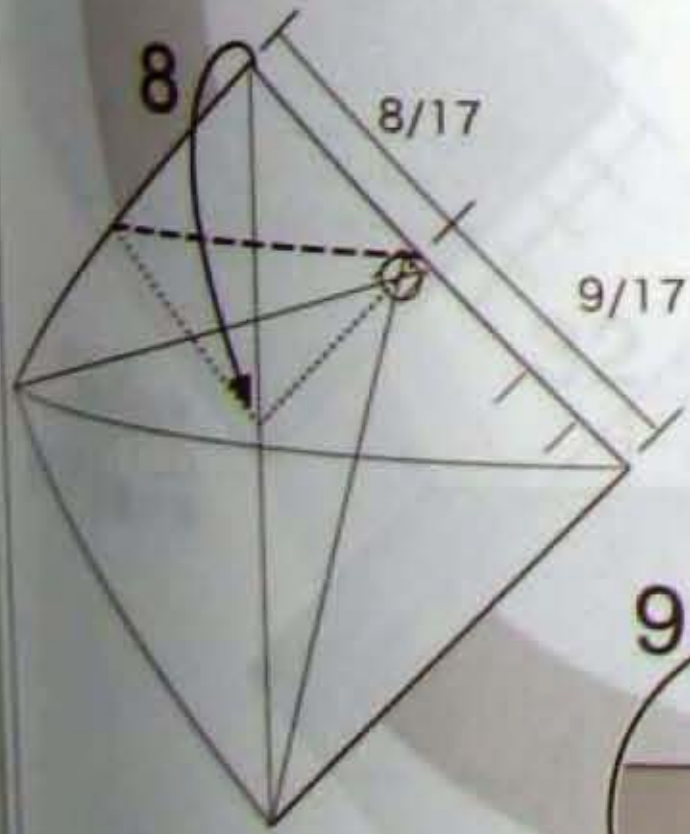

8
フチを折り筋の交点に
合わせて折る

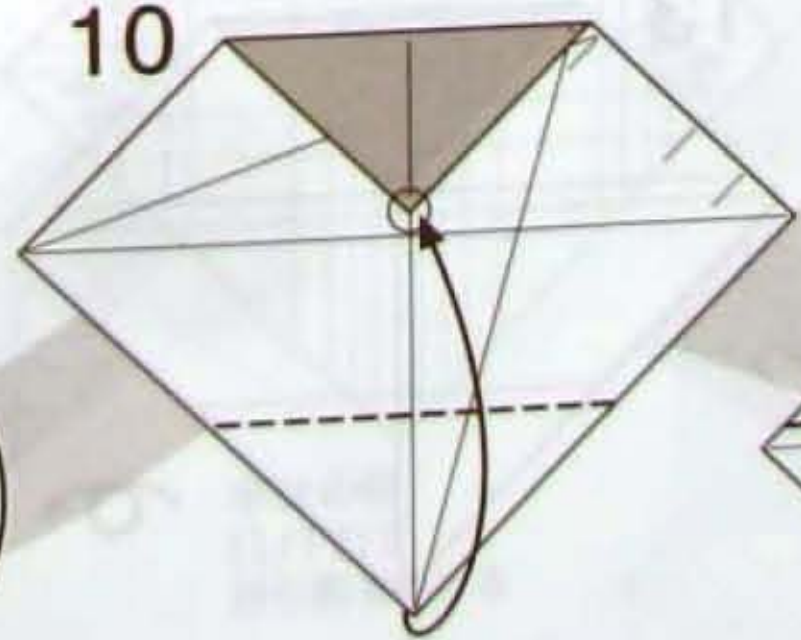
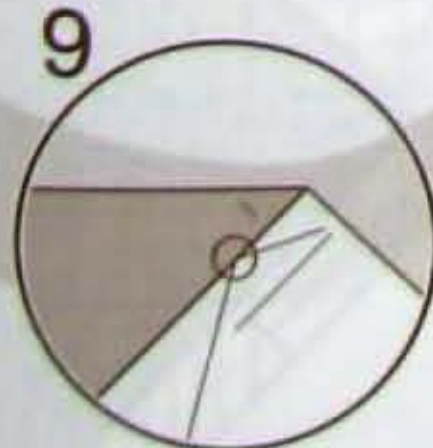

9
カドとカドを合わせて折る

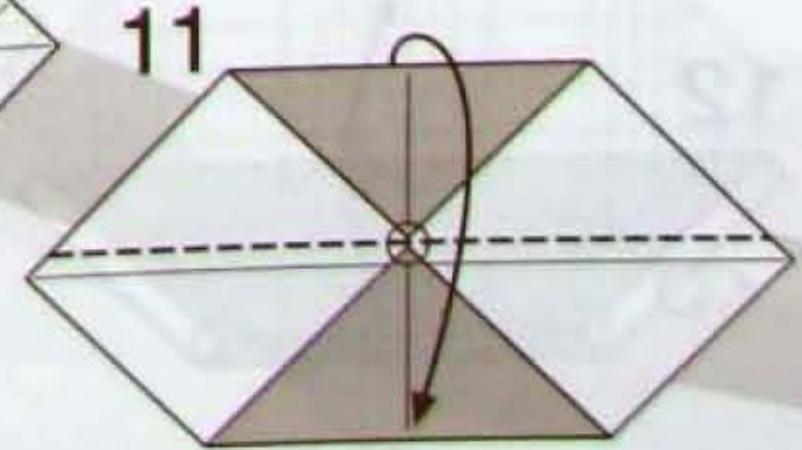

10
カドのところで下へ折る

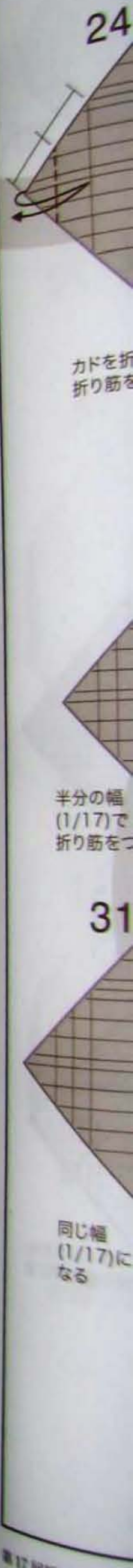
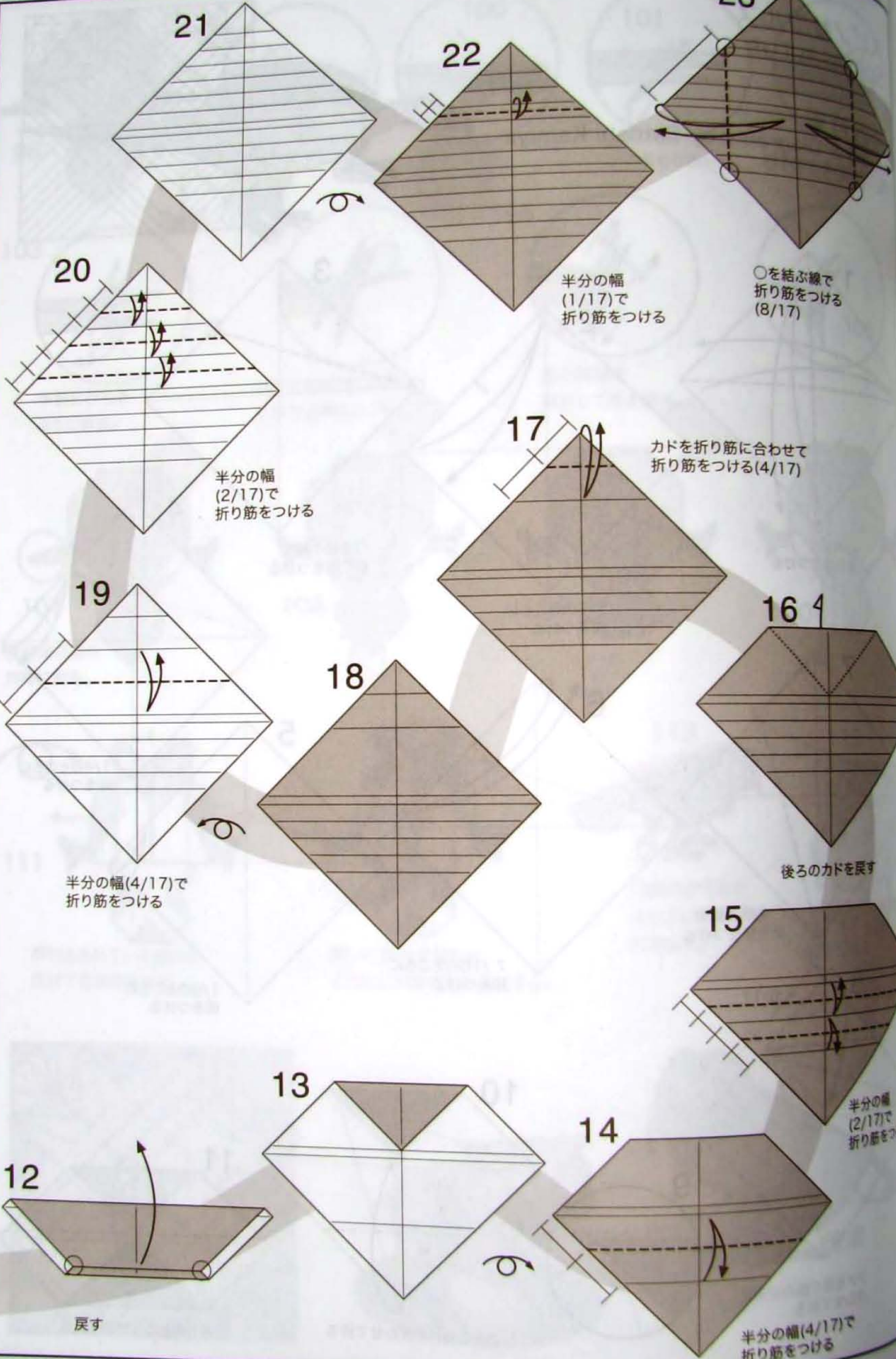

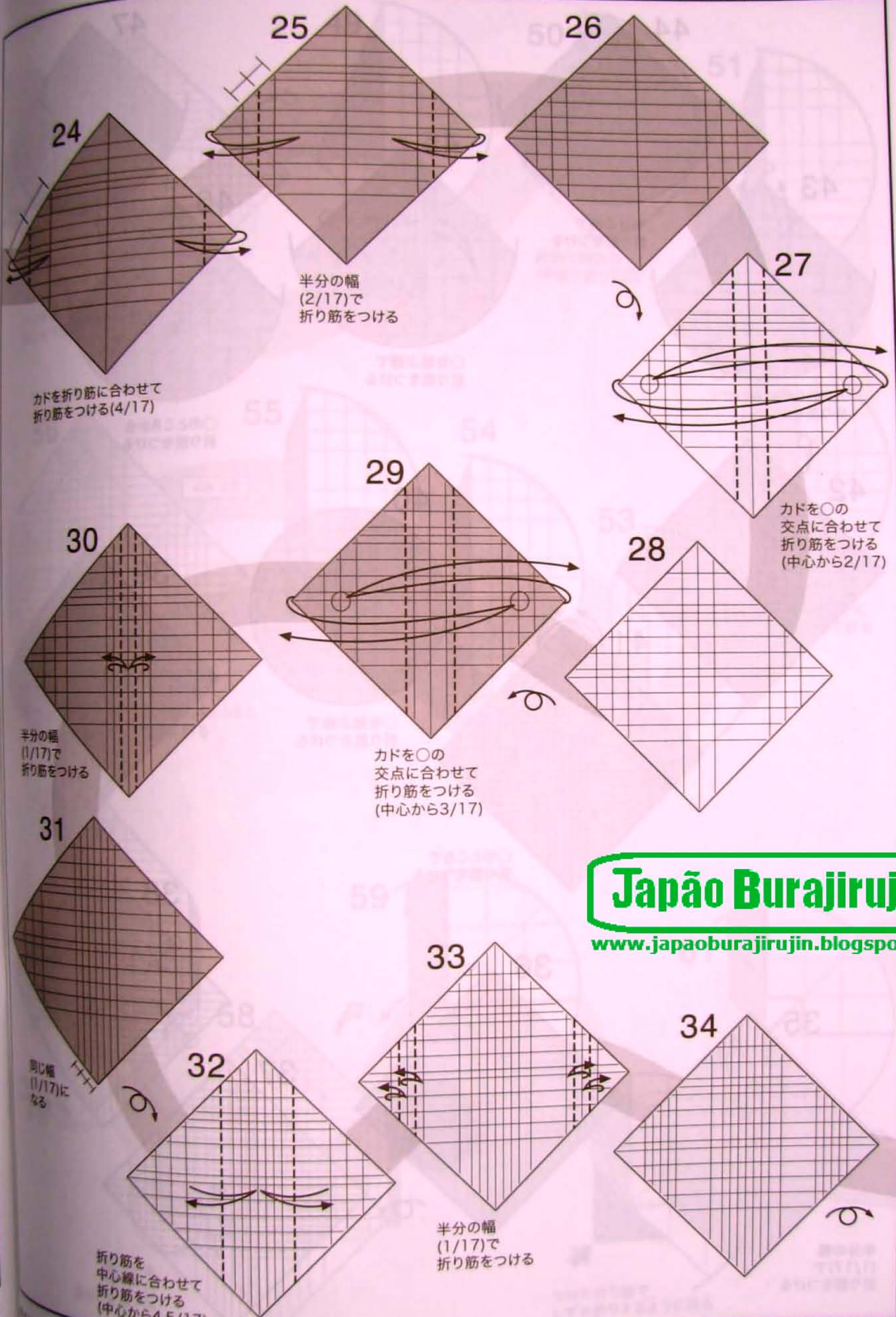

24

カドを折り筋に合わせて
折り筋をつける(4/17)

25

半分の幅
(2/17)で
折り筋をつける

26

27

カドを○の
交点に合わせて
折り筋をつける
(中心から2/17)

29

カドを○の
交点に合わせて
折り筋をつける
(中心から3/17)

28

30

半分の幅
(1/17)で
折り筋をつける

31

同じ幅
(1/17)に
なる

32

折り筋を
中心線に合わせて
折り筋をつける
(中心から4.5/17)

33

半分の幅
(1/17)で
折り筋をつける

34

Japão Burajirujin

www.japaoburajirujin.blogspot.com

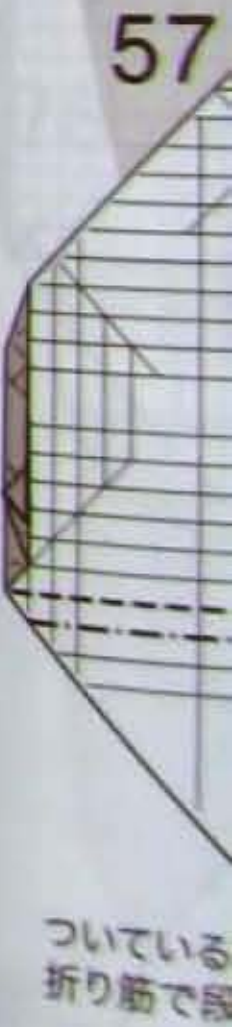
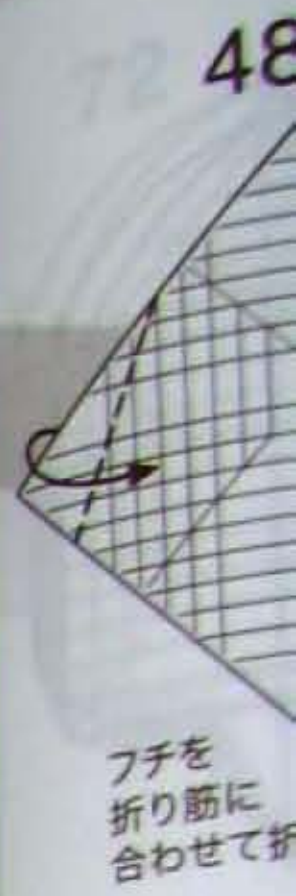
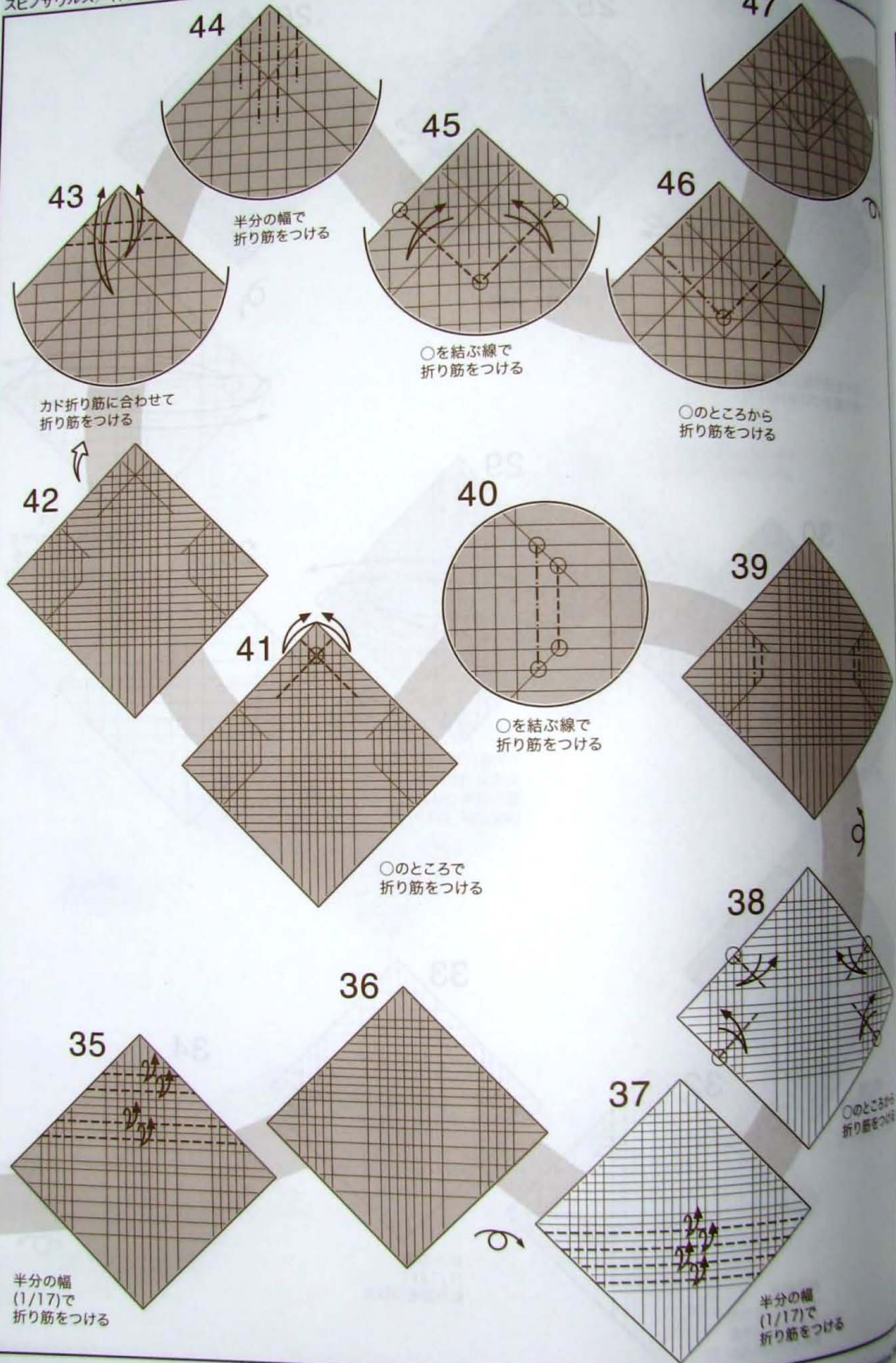

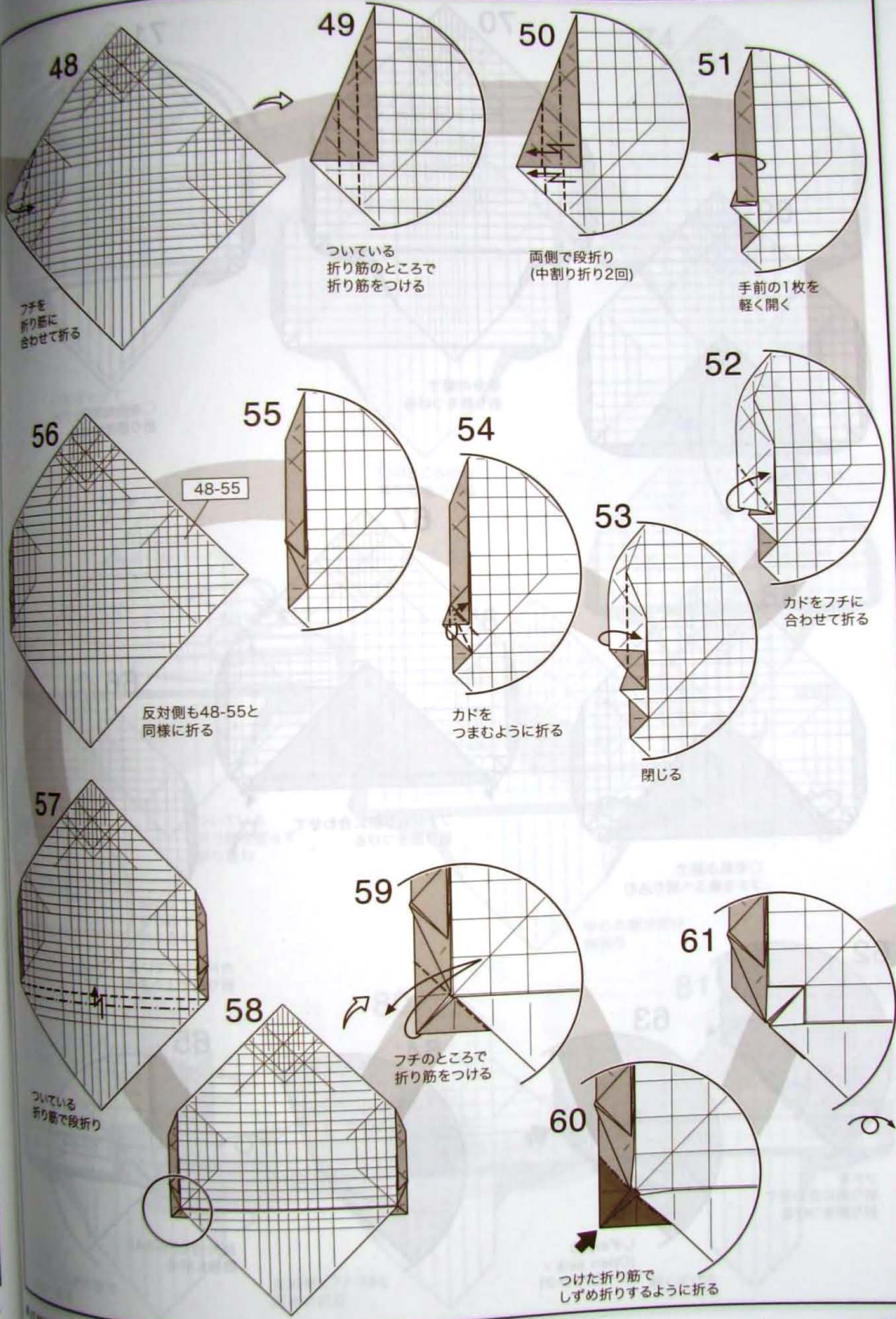

48

フチを
折り筋に
合わせて折る

49

ついている
折り筋のところで
折り筋をつける

50

両側で段折り
(中割り折り2回)

51

手前の1枚を
軽く開く

56

反対側も48-55と
同様に折る

55

48-55

54

カドを
つまむように折る

52

カドをフチに
合わせて折る

53

閉じる

57

ついている
折り筋で段折り

59

フチのところで
折り筋をつける

61

58

60

つけた折り筋で
しずめ折りするように折る

○のところから
折り筋をつける

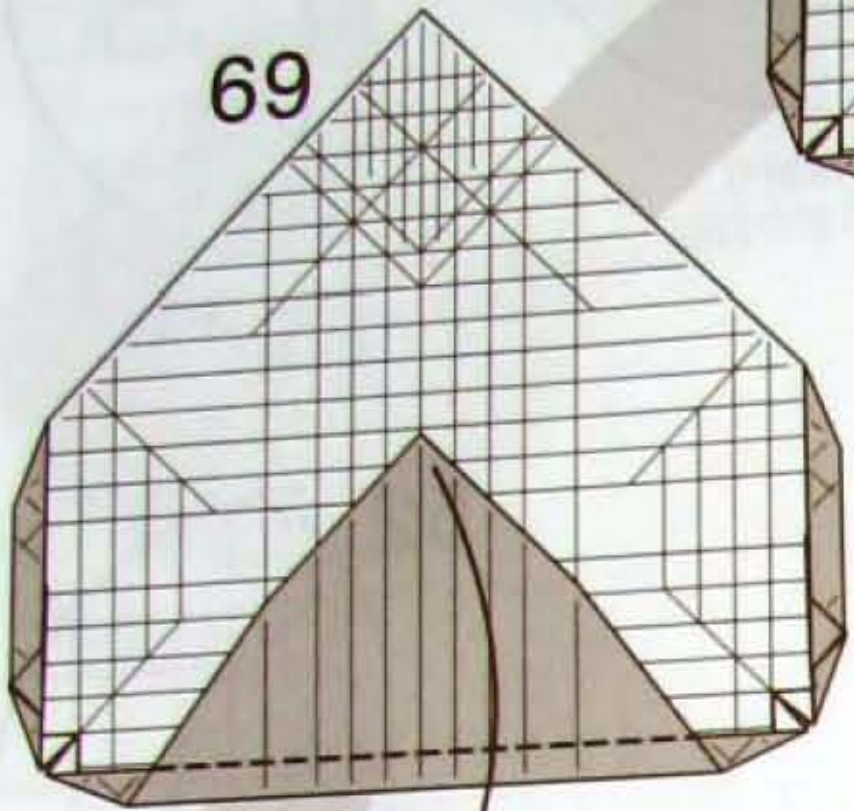

カドを下へ折る

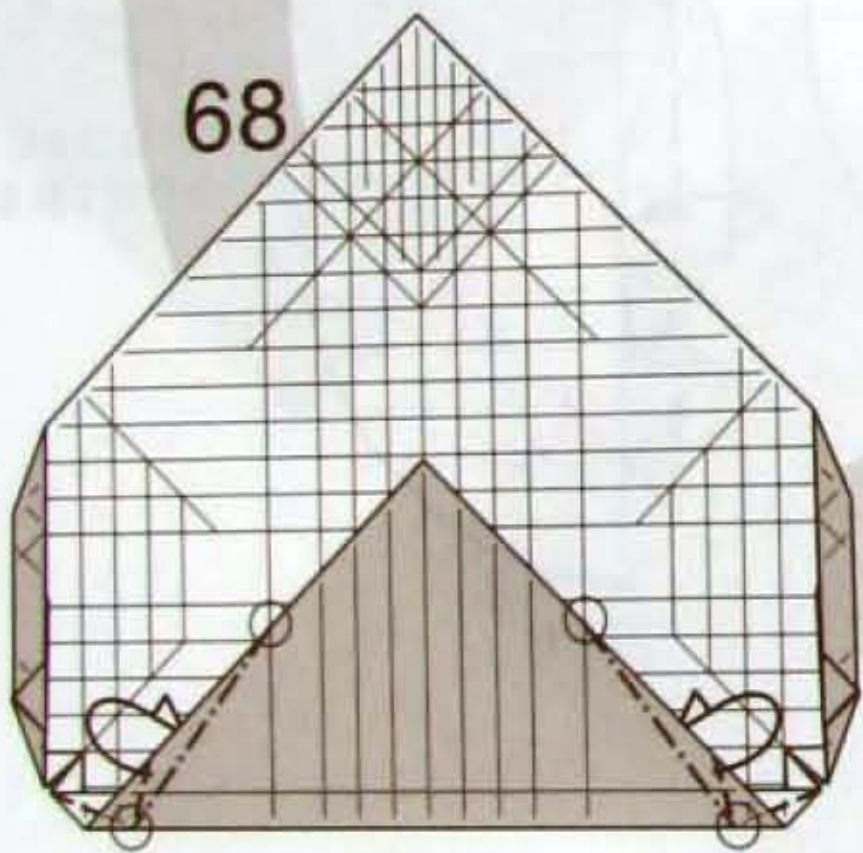

○を結ぶ線で
フチを後ろへ折り込む

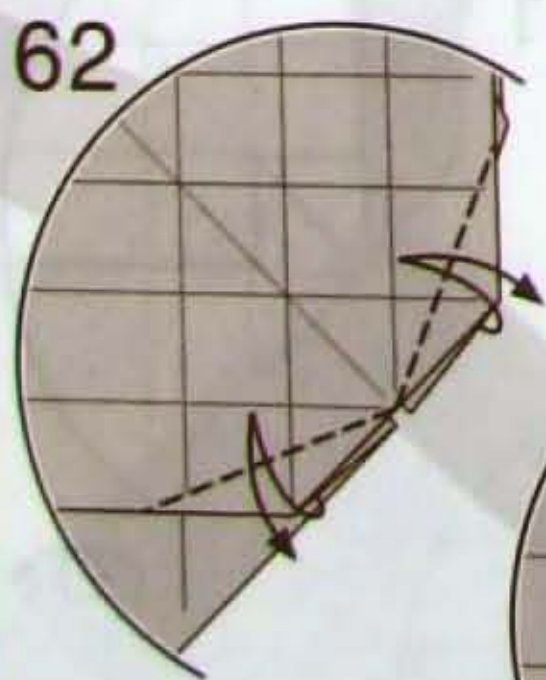

フチを
折り筋に合わせて
折り筋をつける

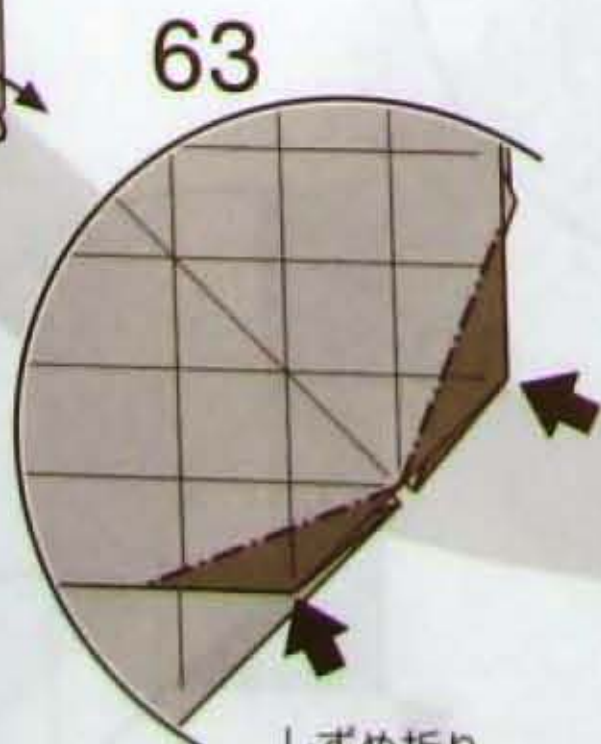

しずめ折り
(Open sink -
オープンシンク)

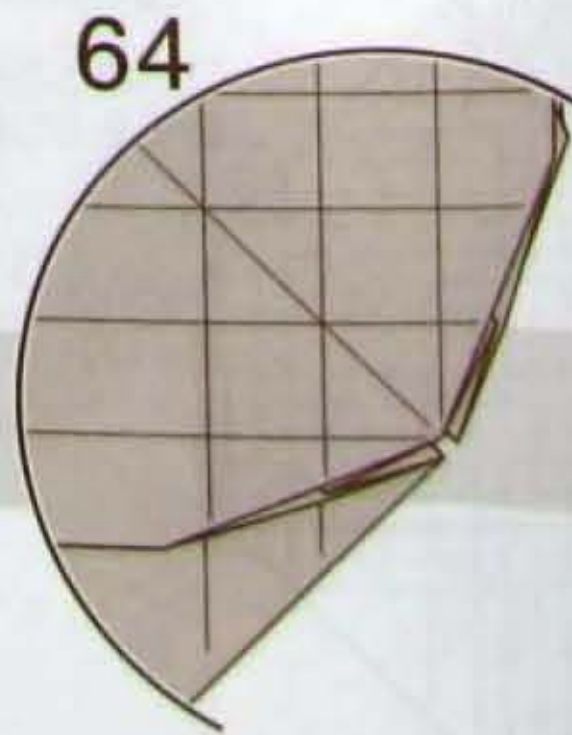

反対側も59-64と
同様に折る

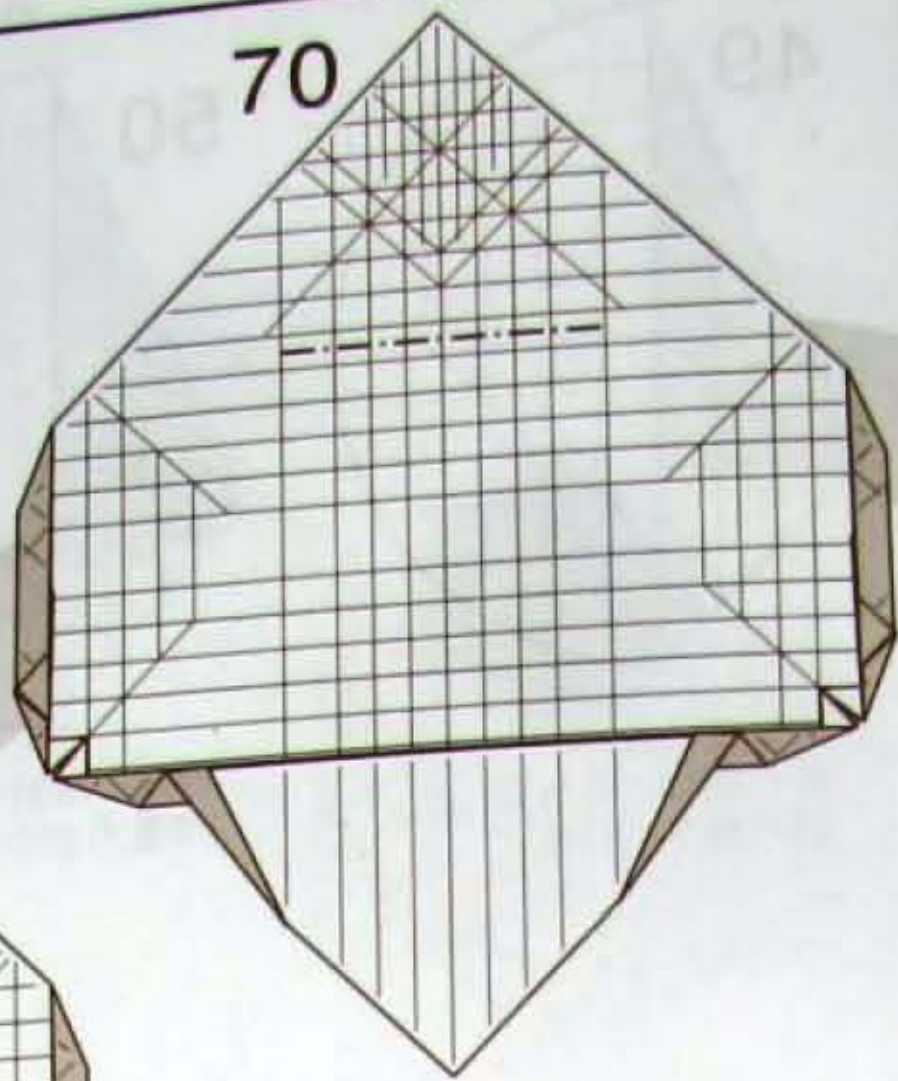

半分の幅で
折り筋をつける

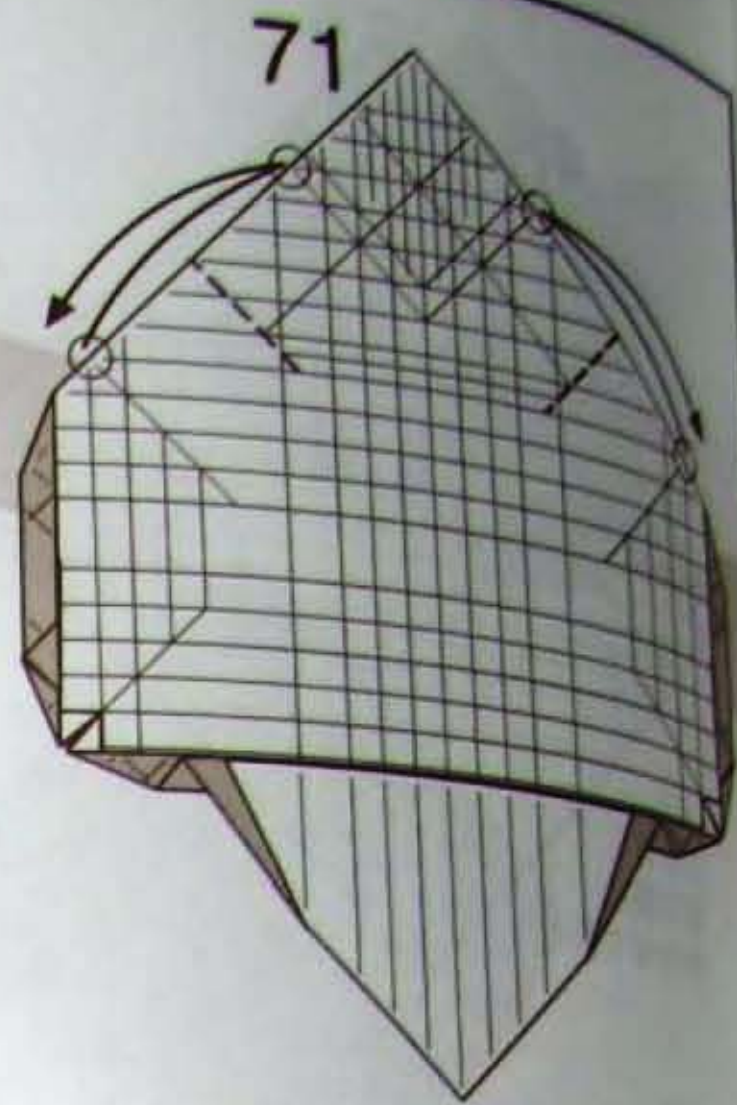

○を合わせて
折り筋をつける

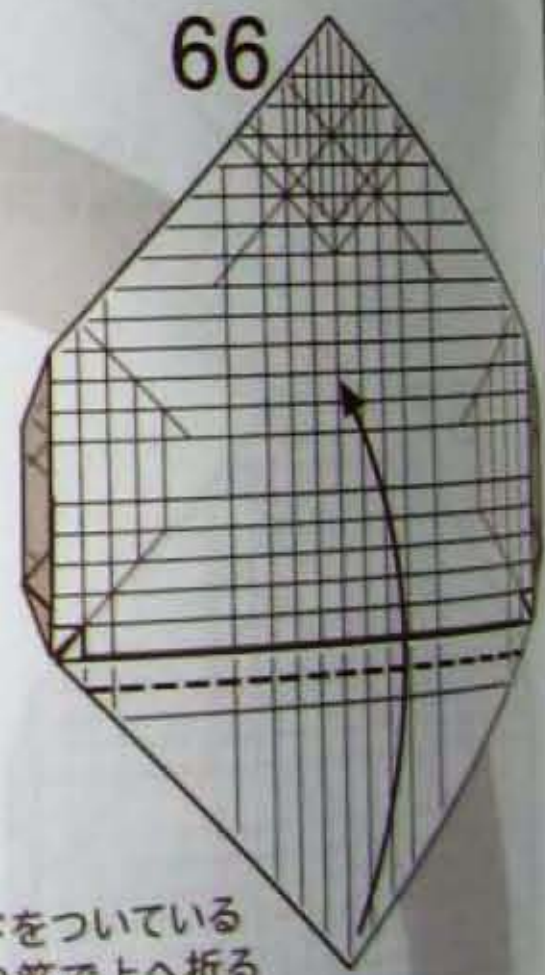

カドをついている
折り筋で上へ折る

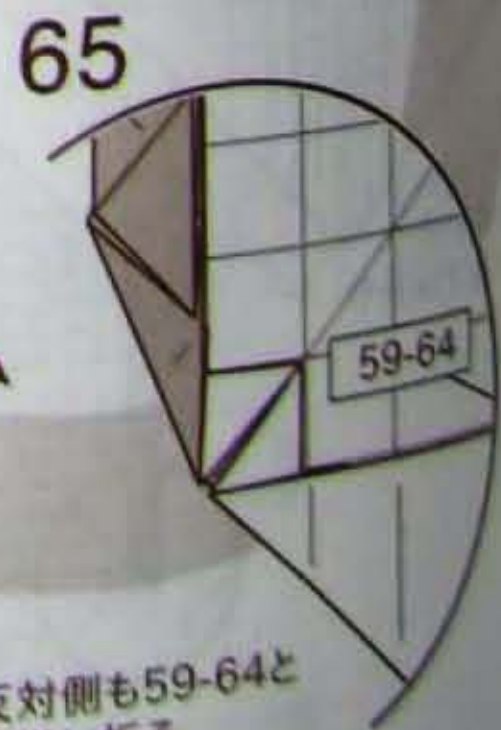

反対側も59-64と
同様に折る

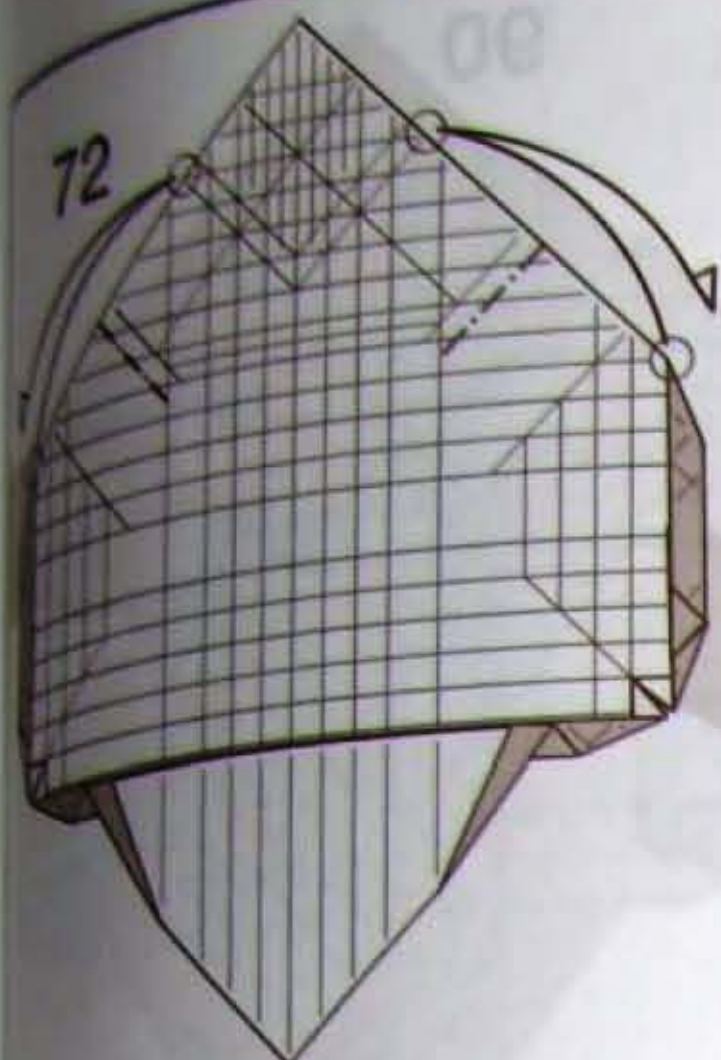

○を合わせて
折り筋をつける

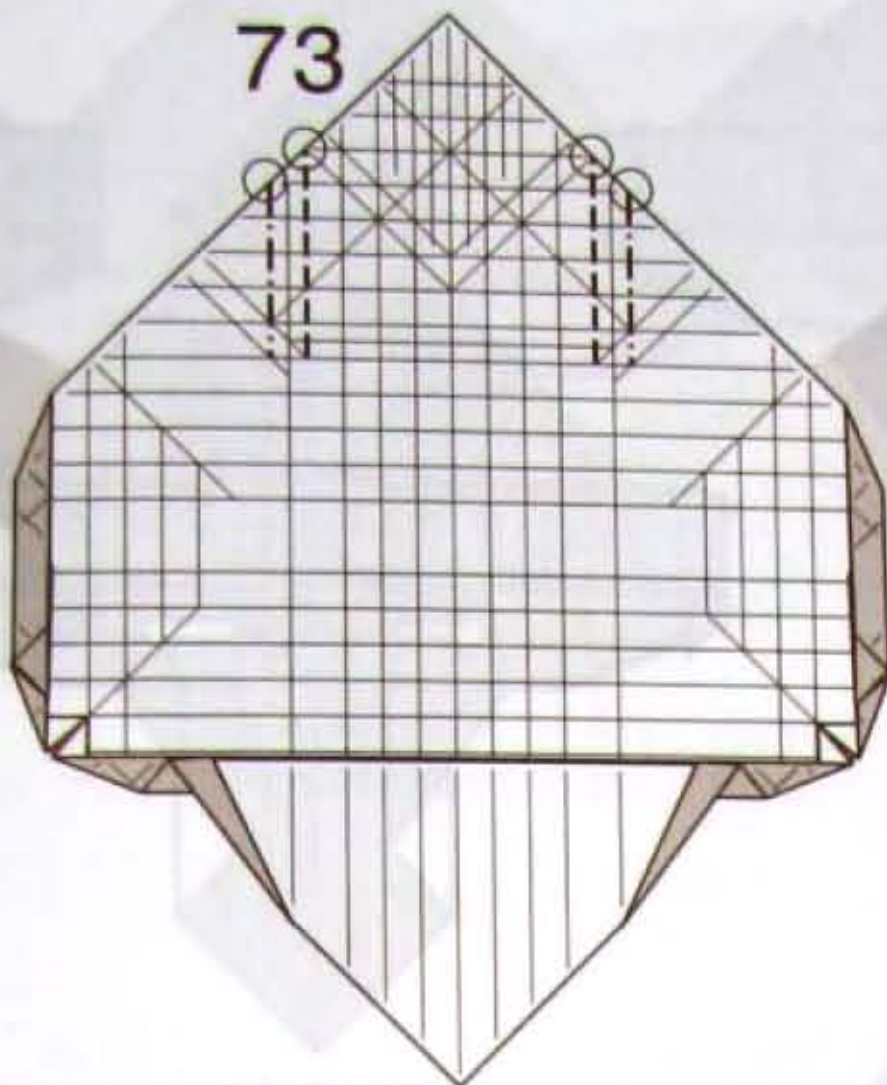

○のところから
折り筋をつける

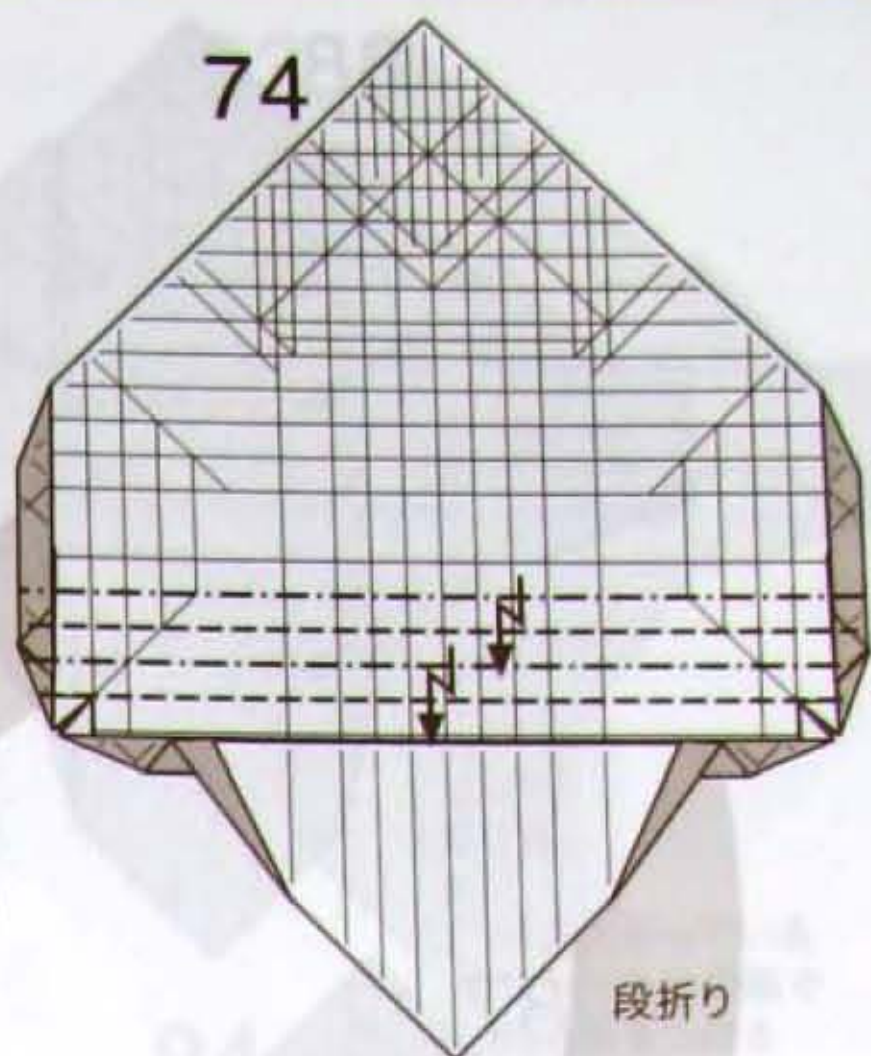

段折り

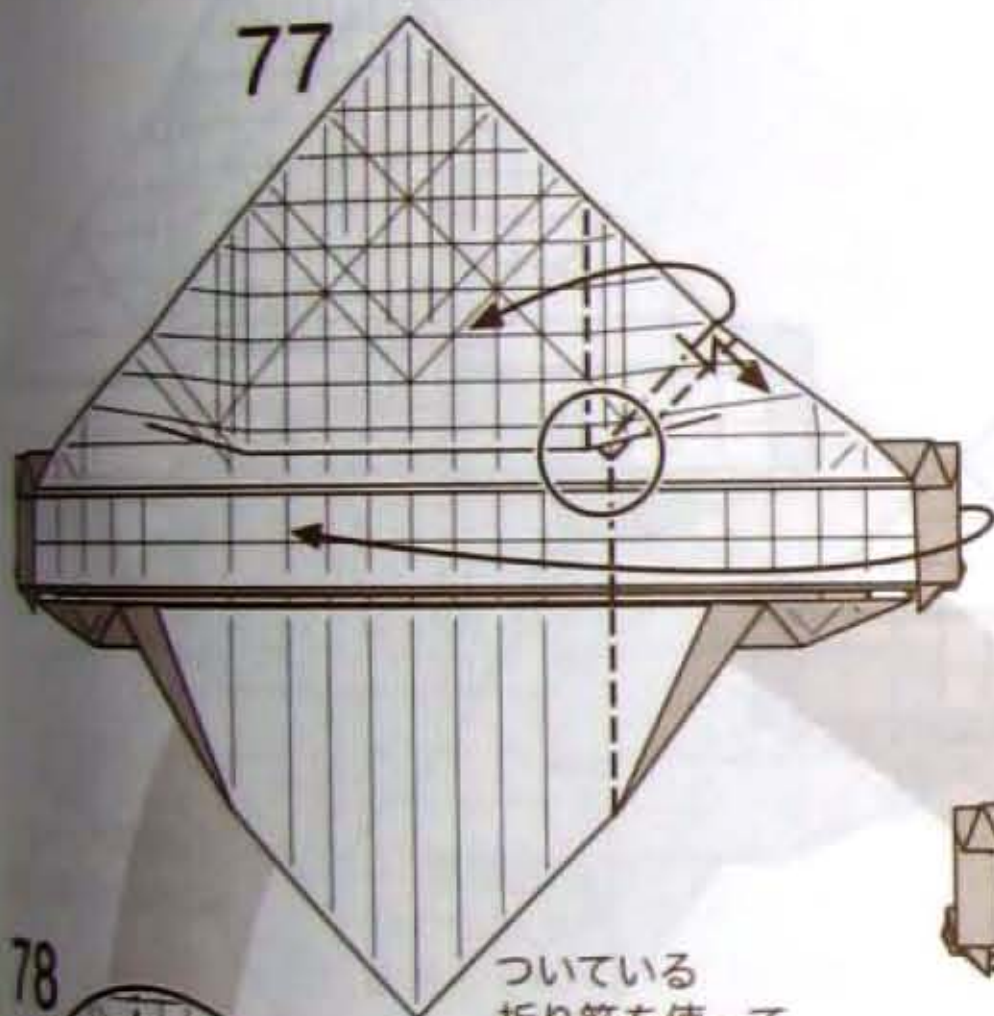

ついている
折り筋を使って
折り畳む

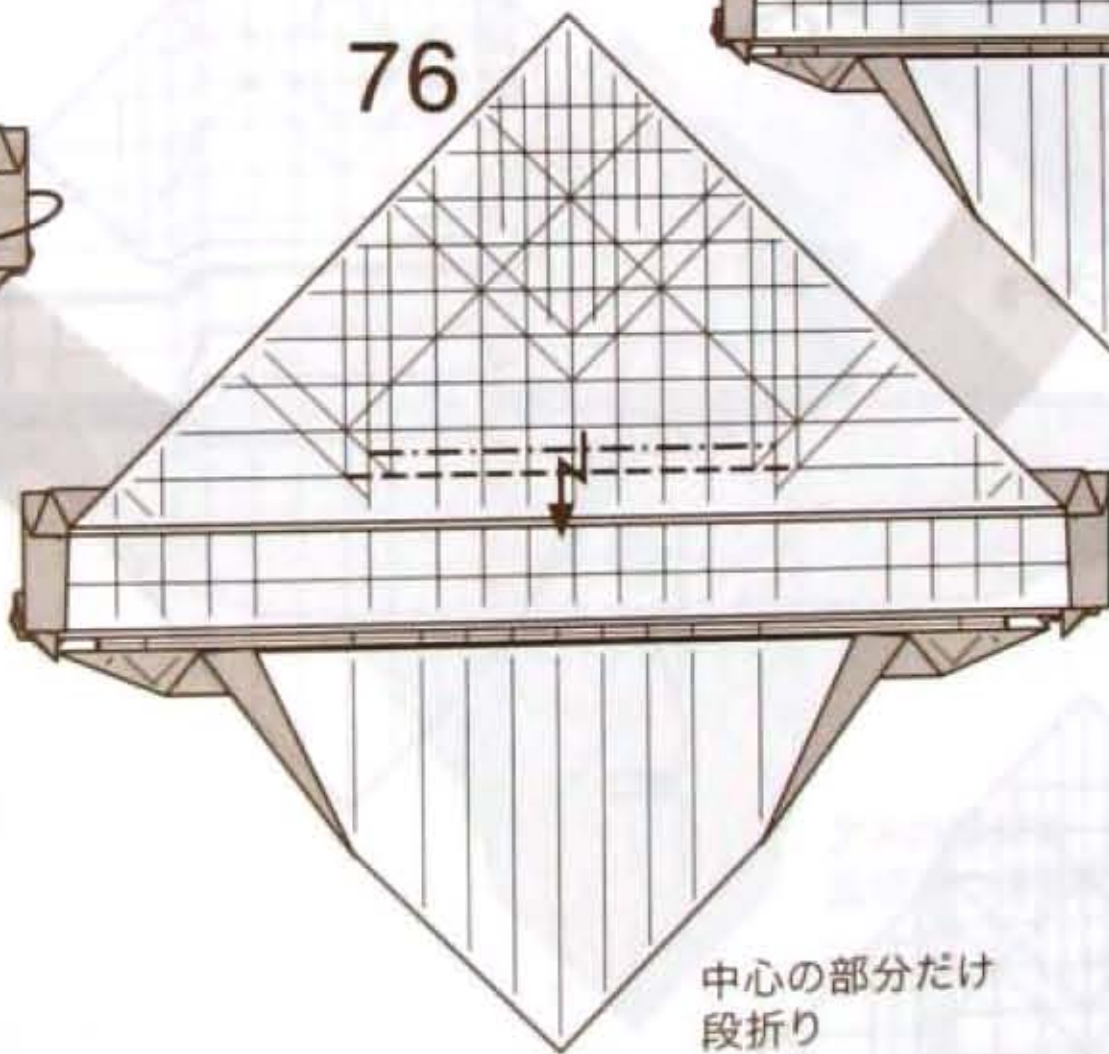

中心の部分だけ
段折り

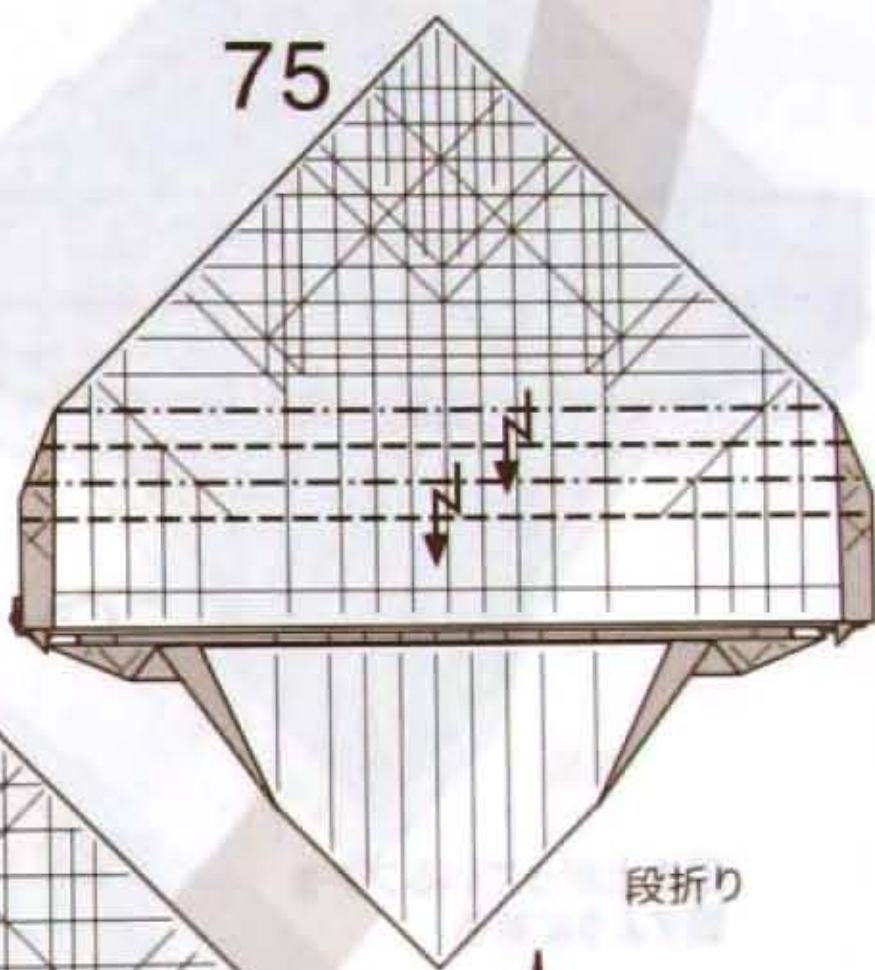

段折り

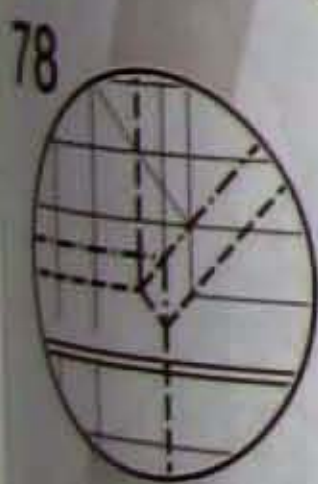

図のような
折り筋で
折り畳む

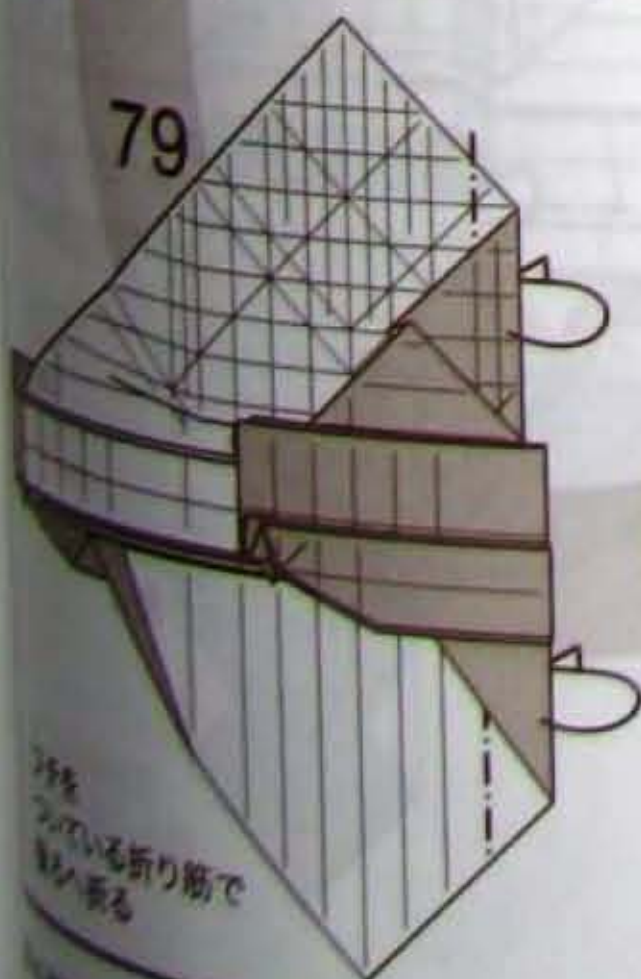

ついている折り筋で
折り畳む

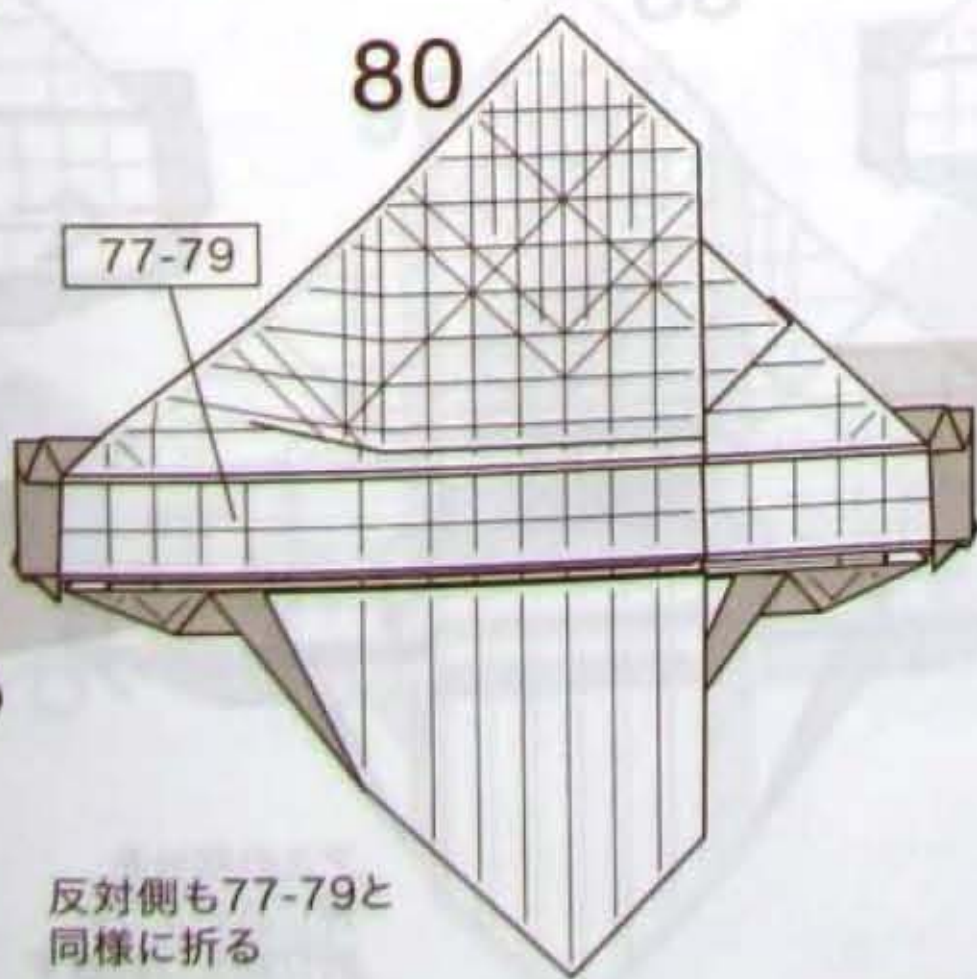

反対側も77-79と
同様に折る

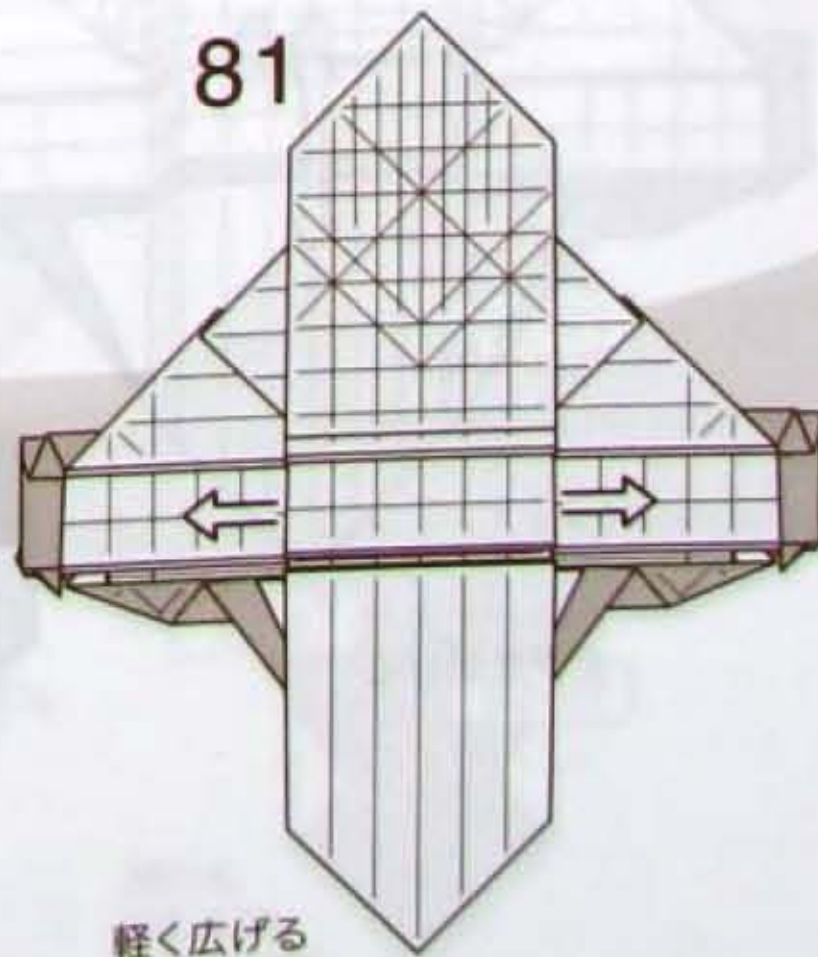

軽く広げる

88

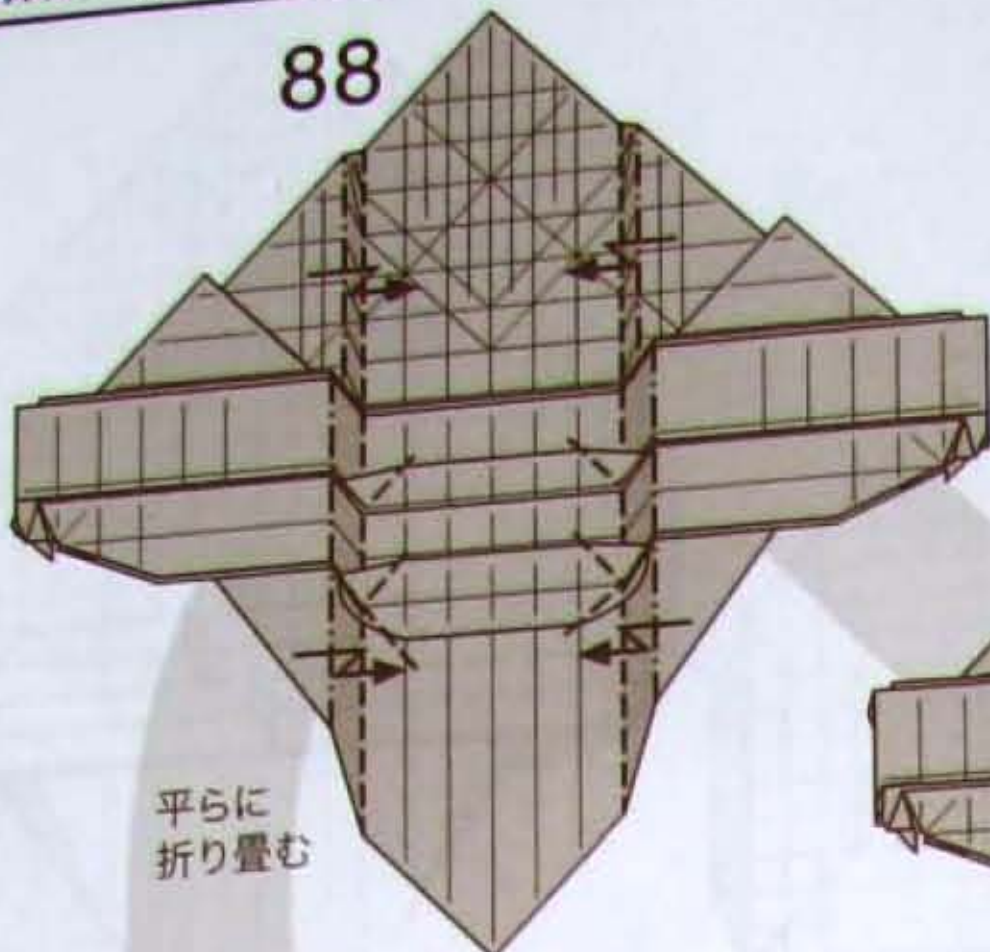

平らに
折り畳む

89

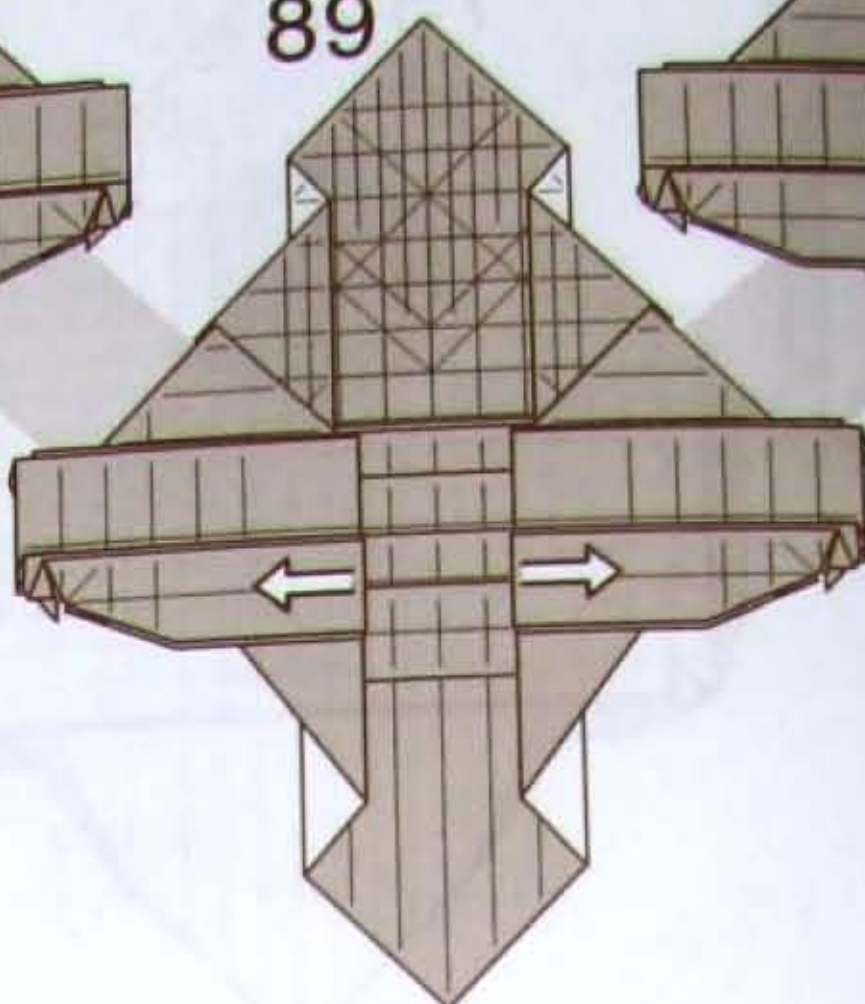

軽く広げる

90

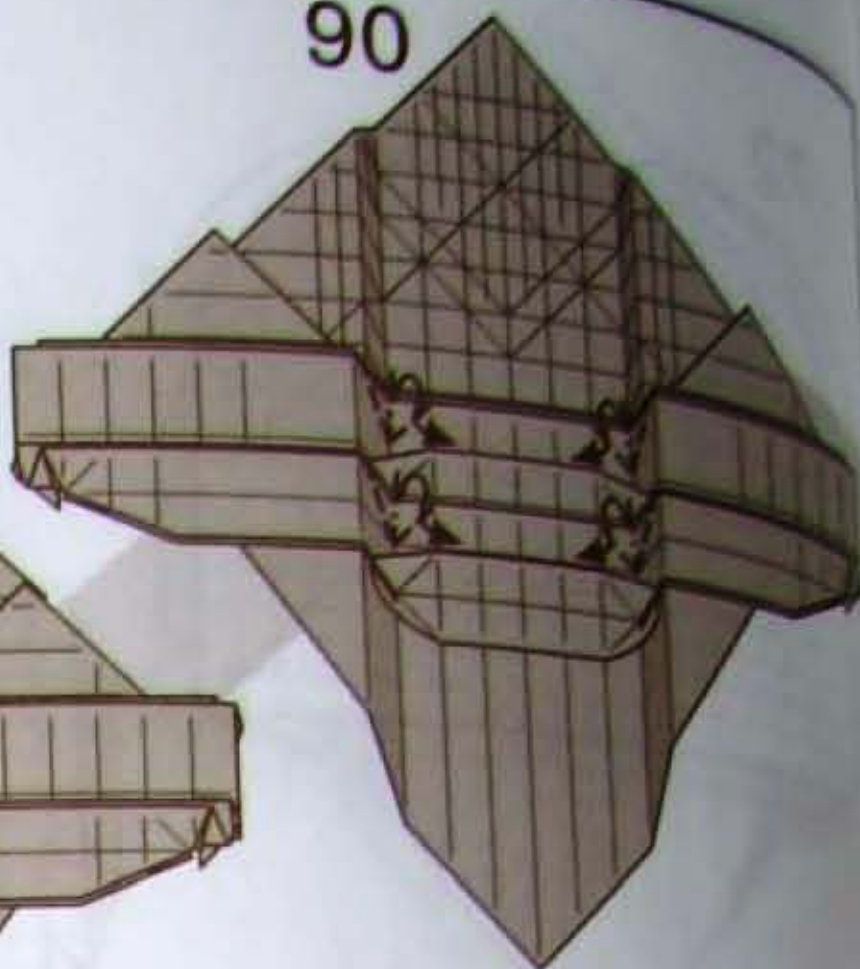

フチを中割り折り

87

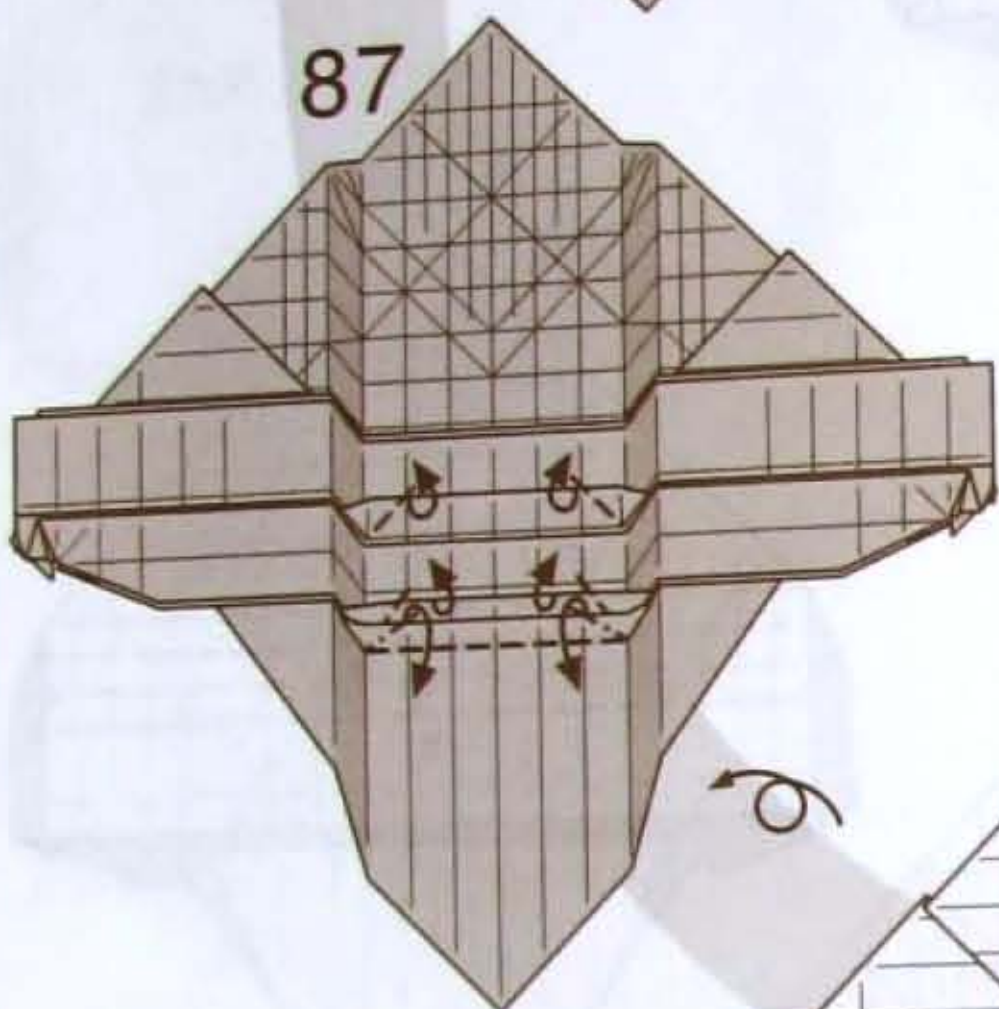

起き上がっているフチを
倒すように折る

86

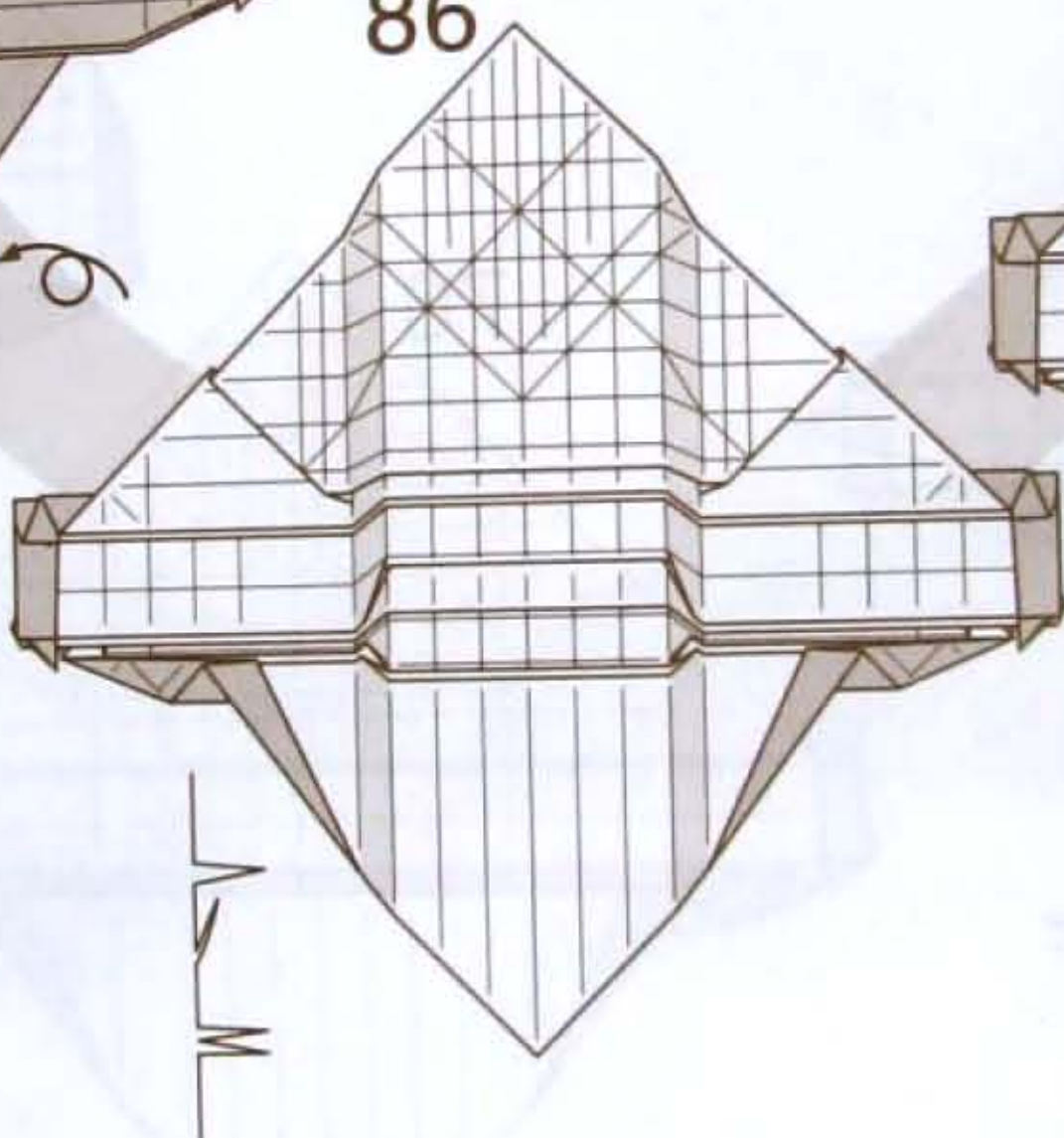

85

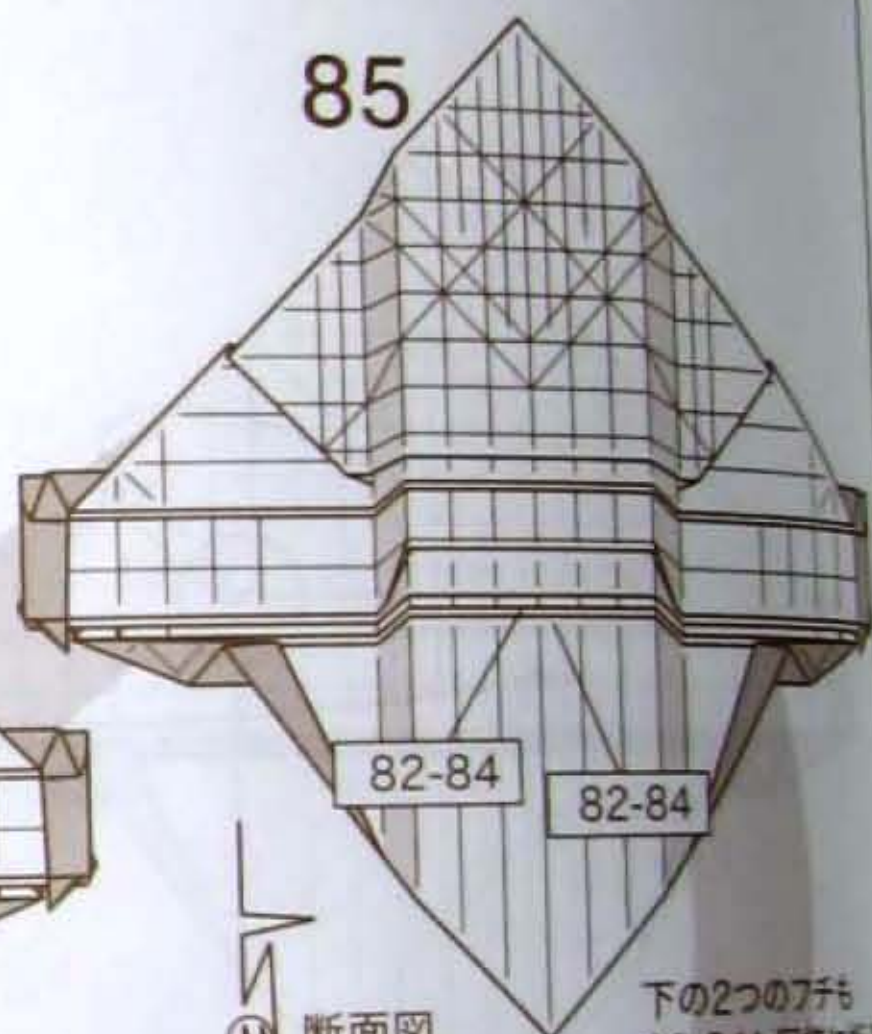

断面図
○の2つの
フチを折る

下の2つのフチも
82-84と同様に折る

82

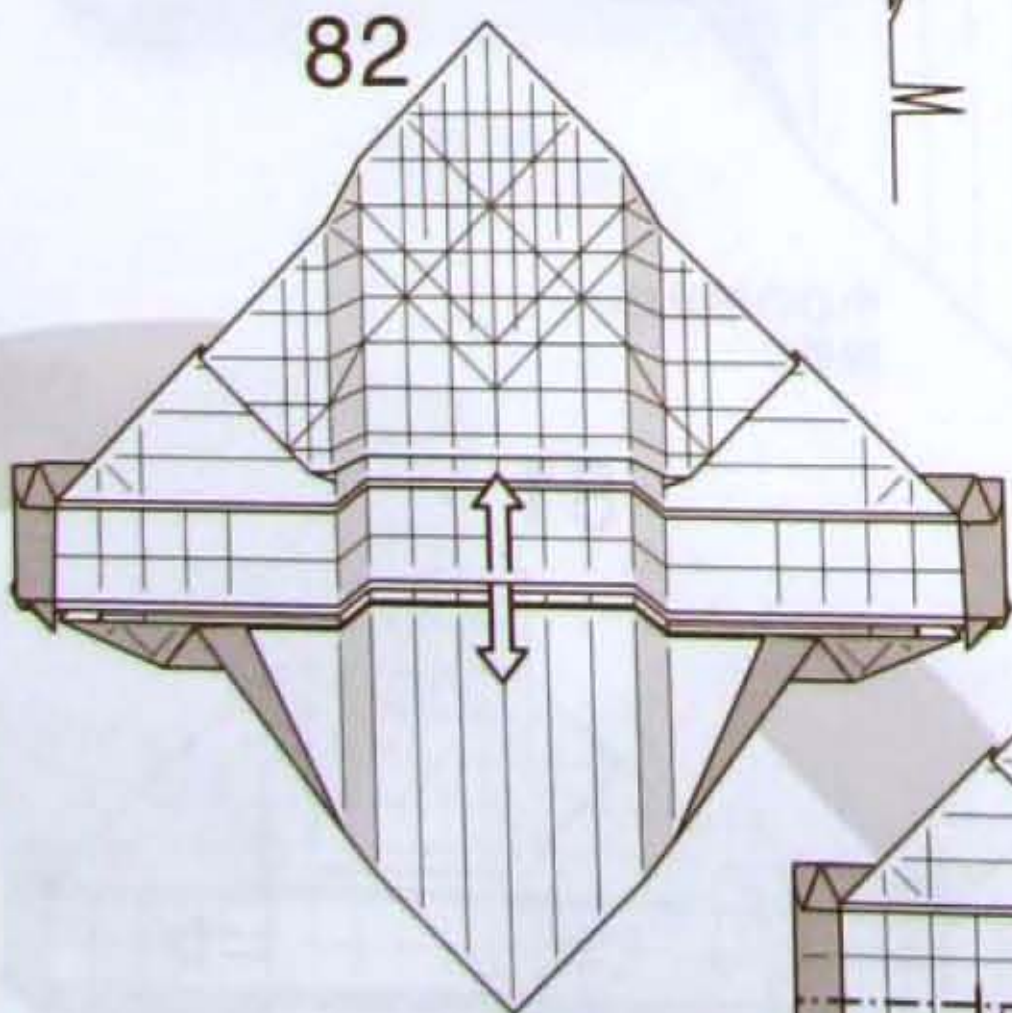

ヒダを広げる

83

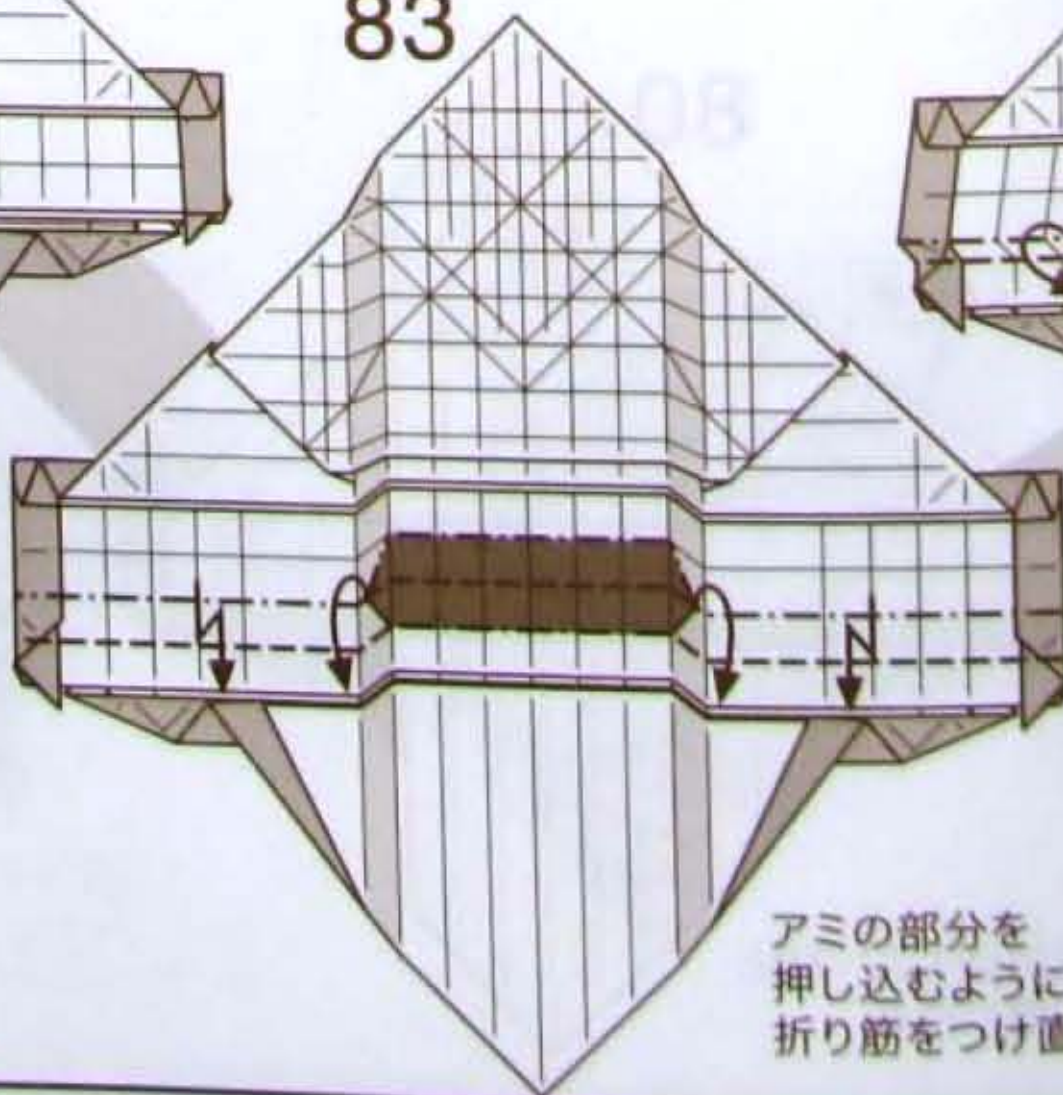

アミの部分を
押し込むように
折り筋をつけ直す

84

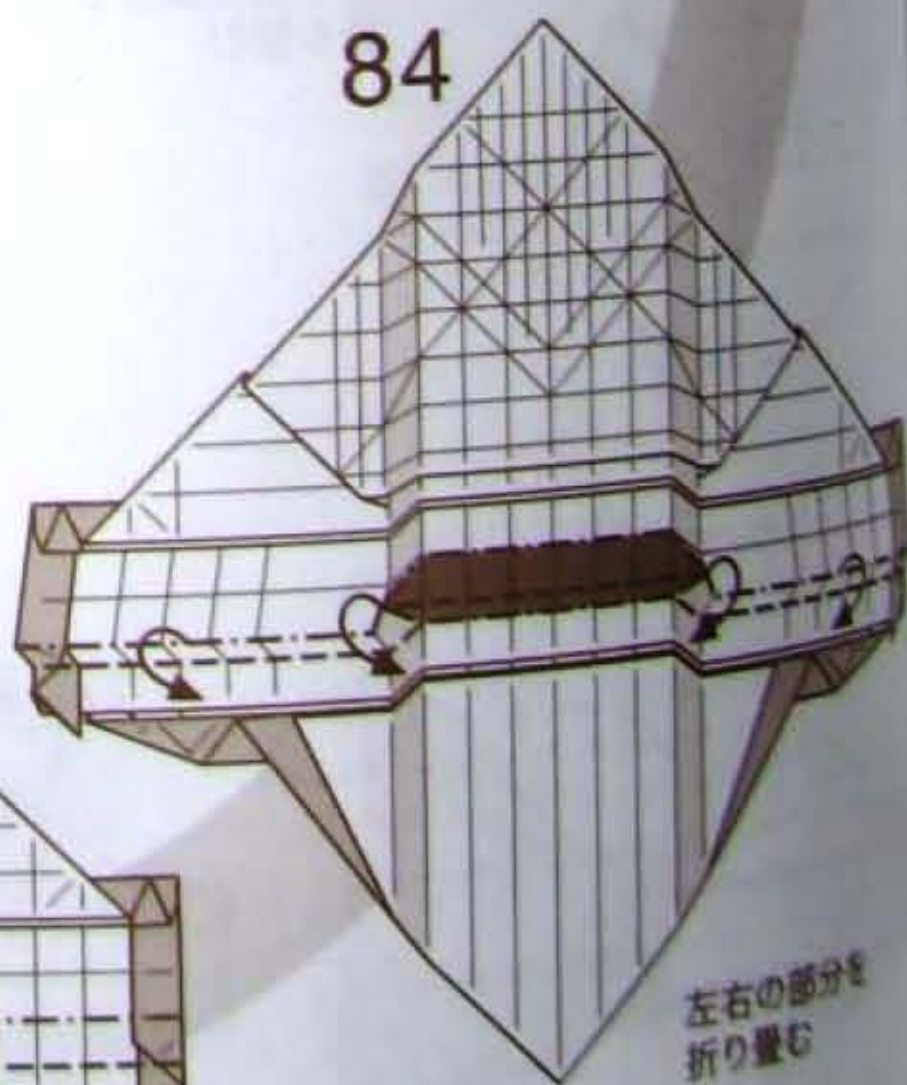

左右の部分を
折り畳む

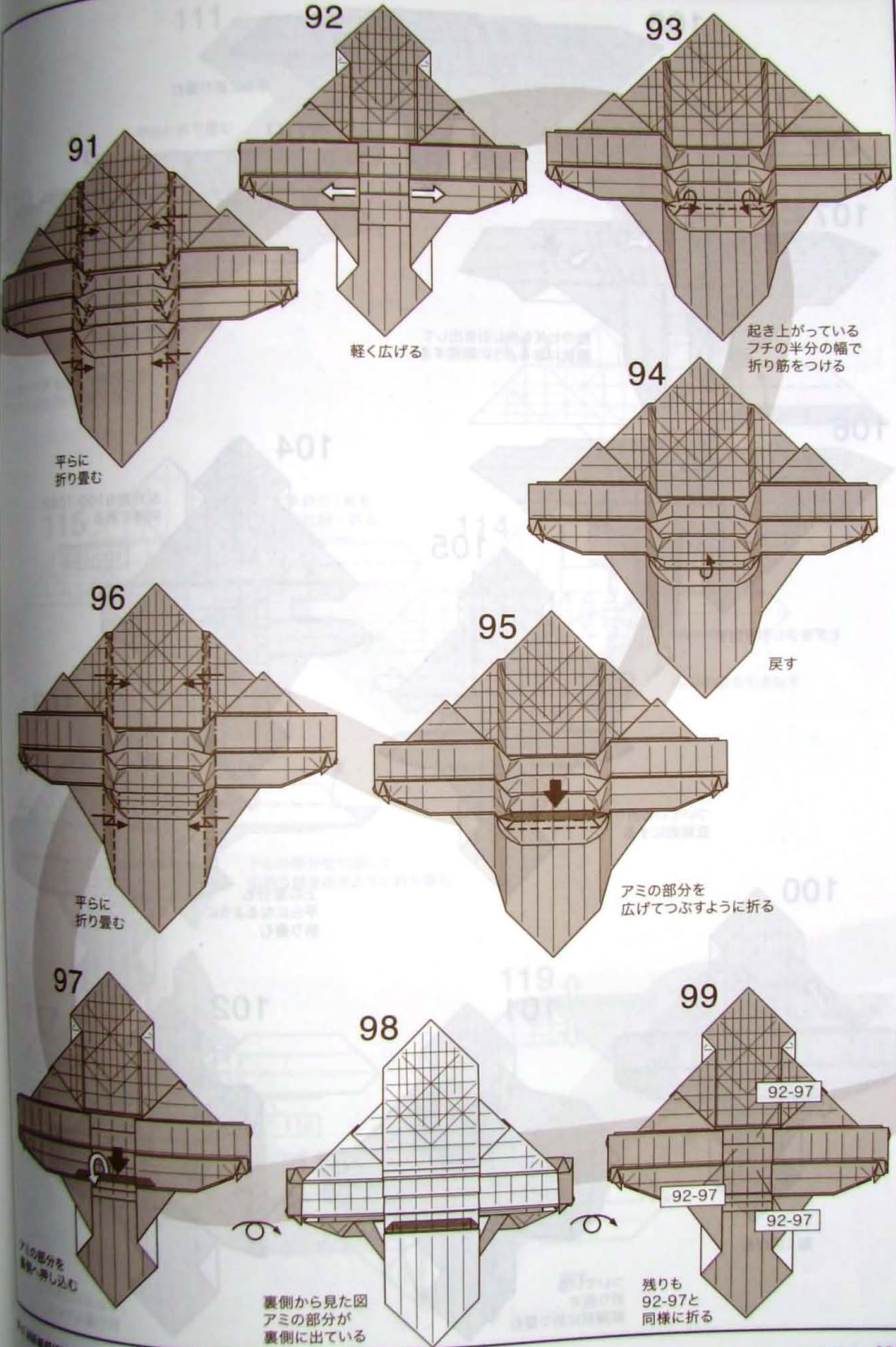

91

平らに
折り畳む

92

軽く広げる

93

起き上がっている
フチの半分の幅で
折り筋をつける

94

戻す

96

平らに
折り畳む

95

アミの部分を
広げてつぶすように折る

97

アミ部分を
裏側に押し込む

98

裏側から見た図
アミの部分が
裏側に出ている

99

残りも
92-97と
同様に折る

92-97

92-97

92-97

108

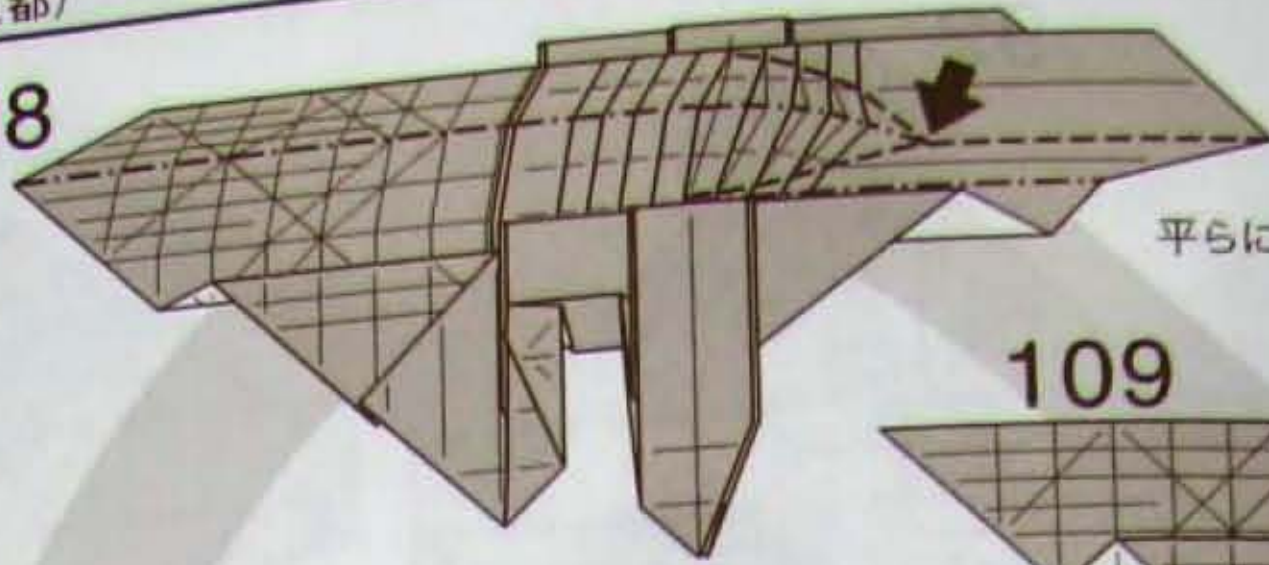

平らに折り畳む

109

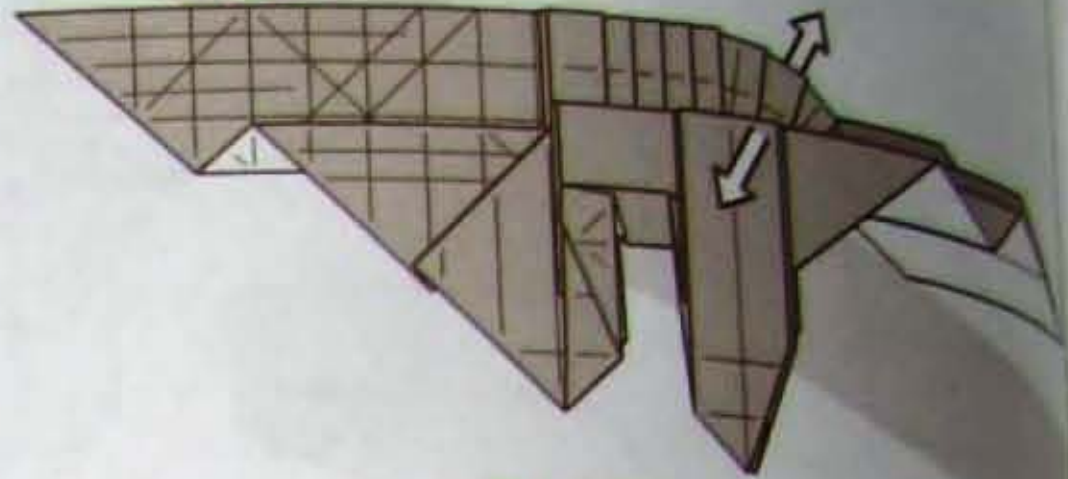

軽く広げる

107

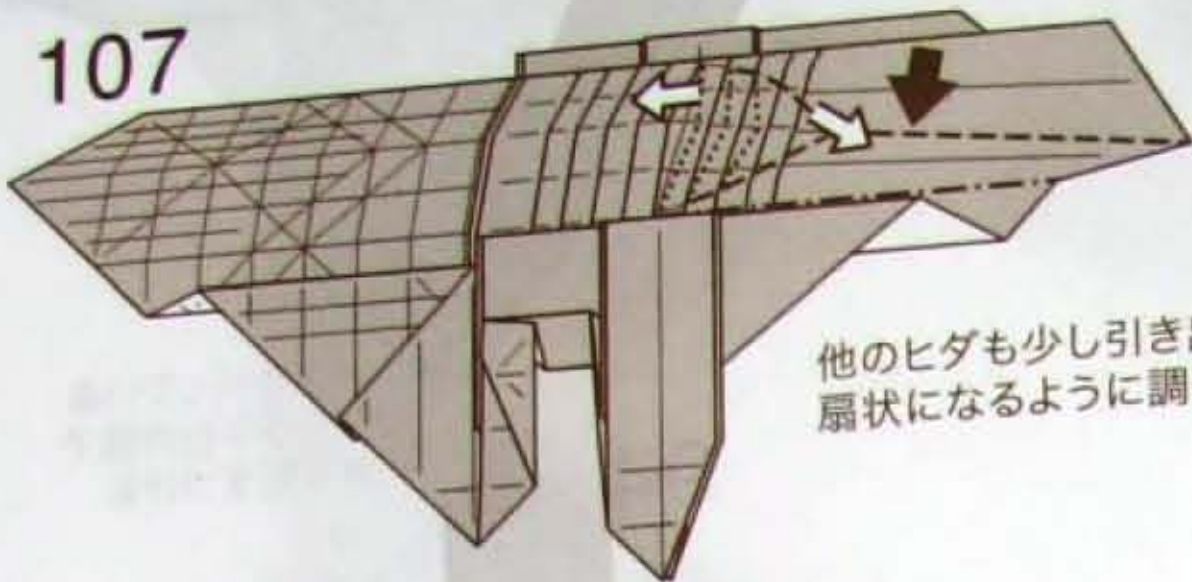

他のヒダも少し引き出して扇状になるように調整する

106

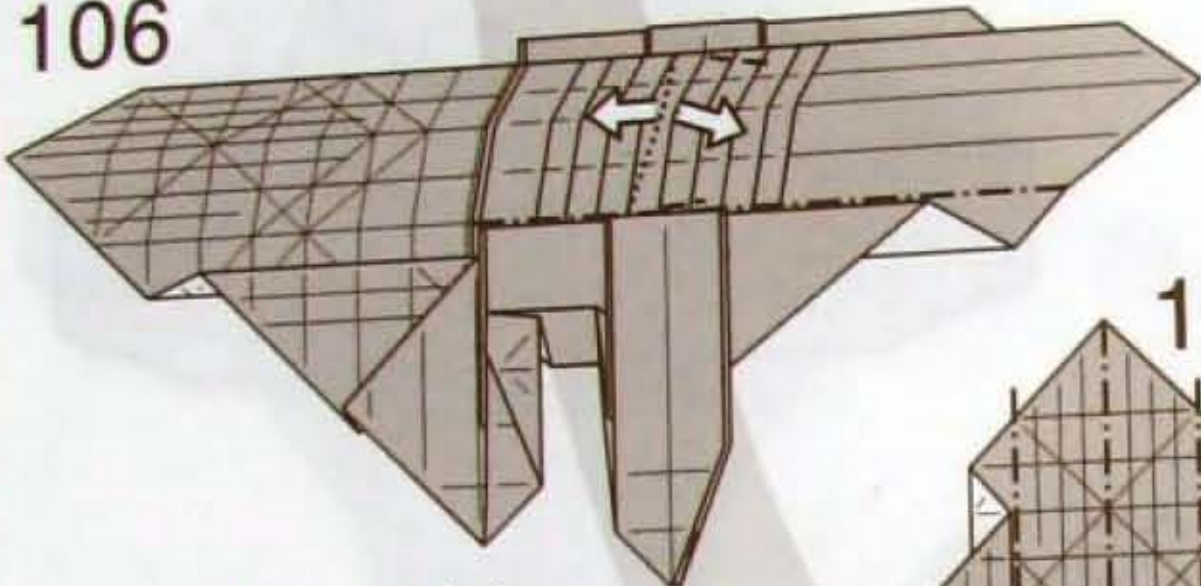

ヒダを少し引き出す

104

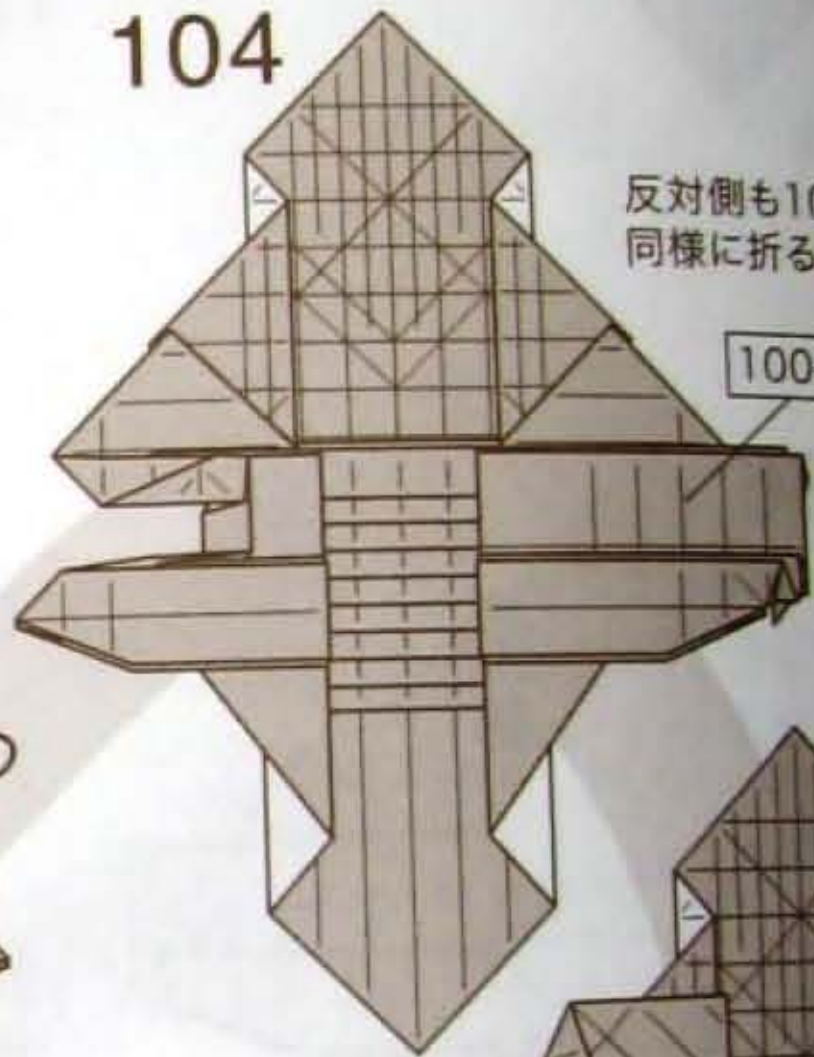

反対側も100-103と同様に折る

100-103

105

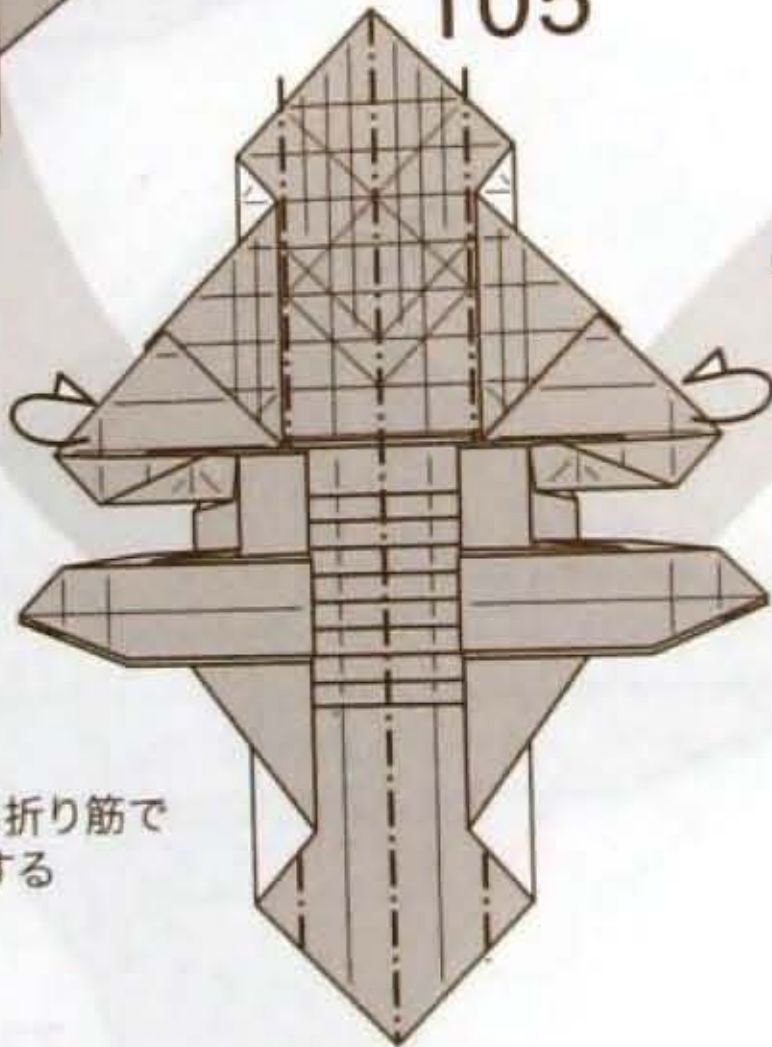

ついている折り筋で立体的にする

103

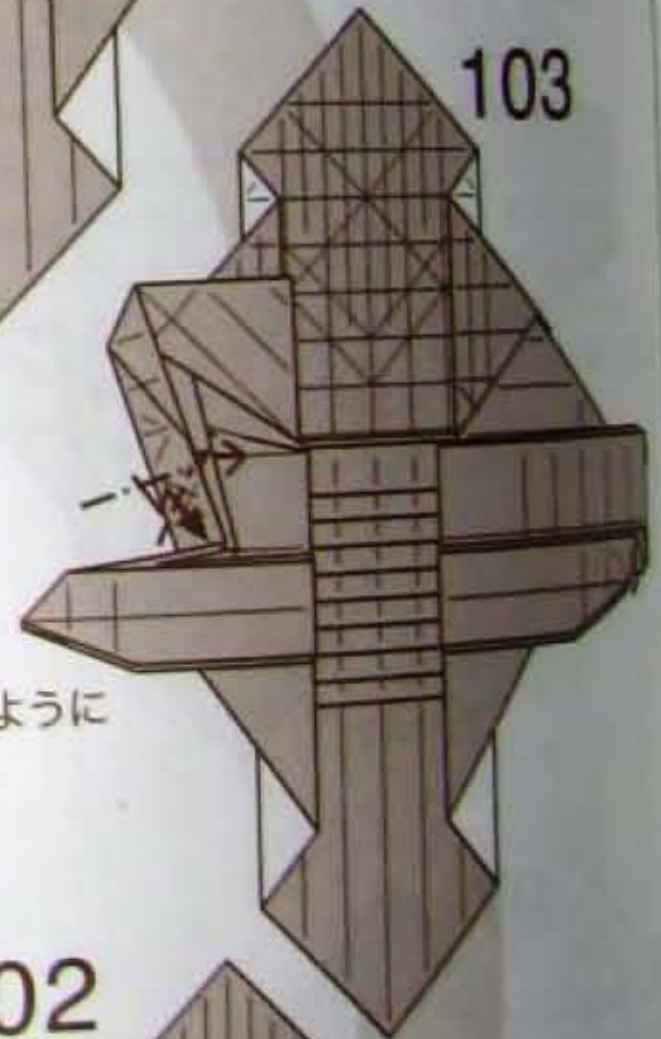

上の部分も平らになるように折り畳む

100

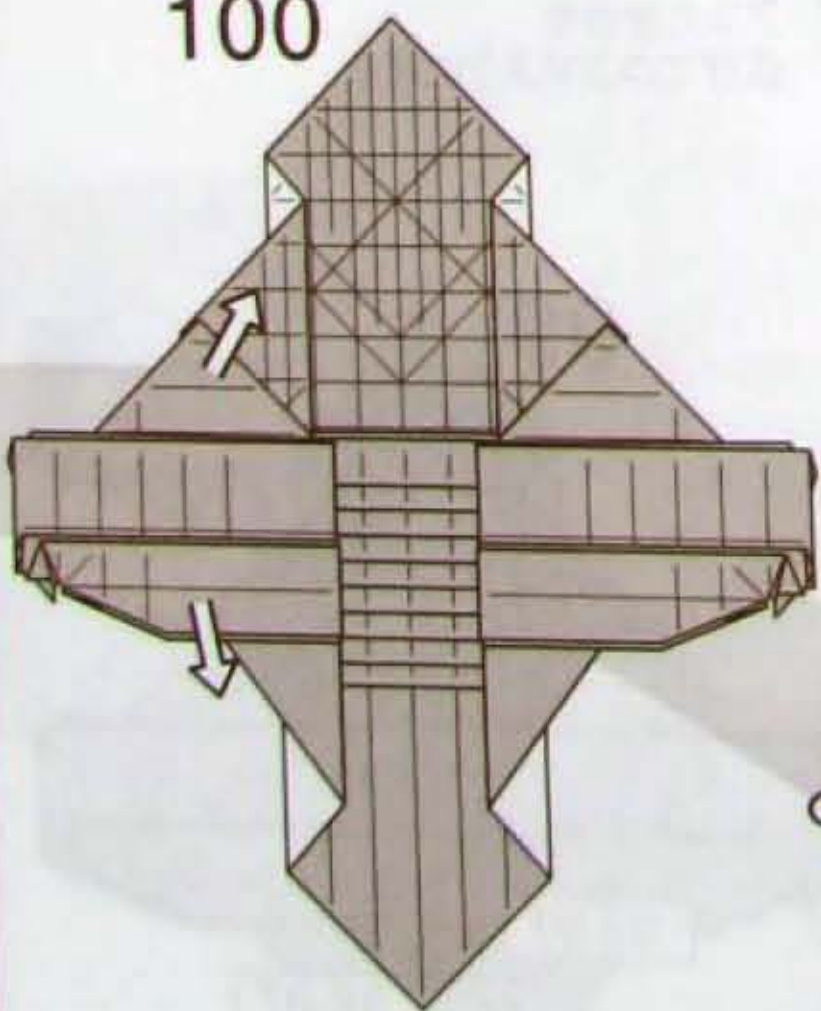

軽く広げる

101

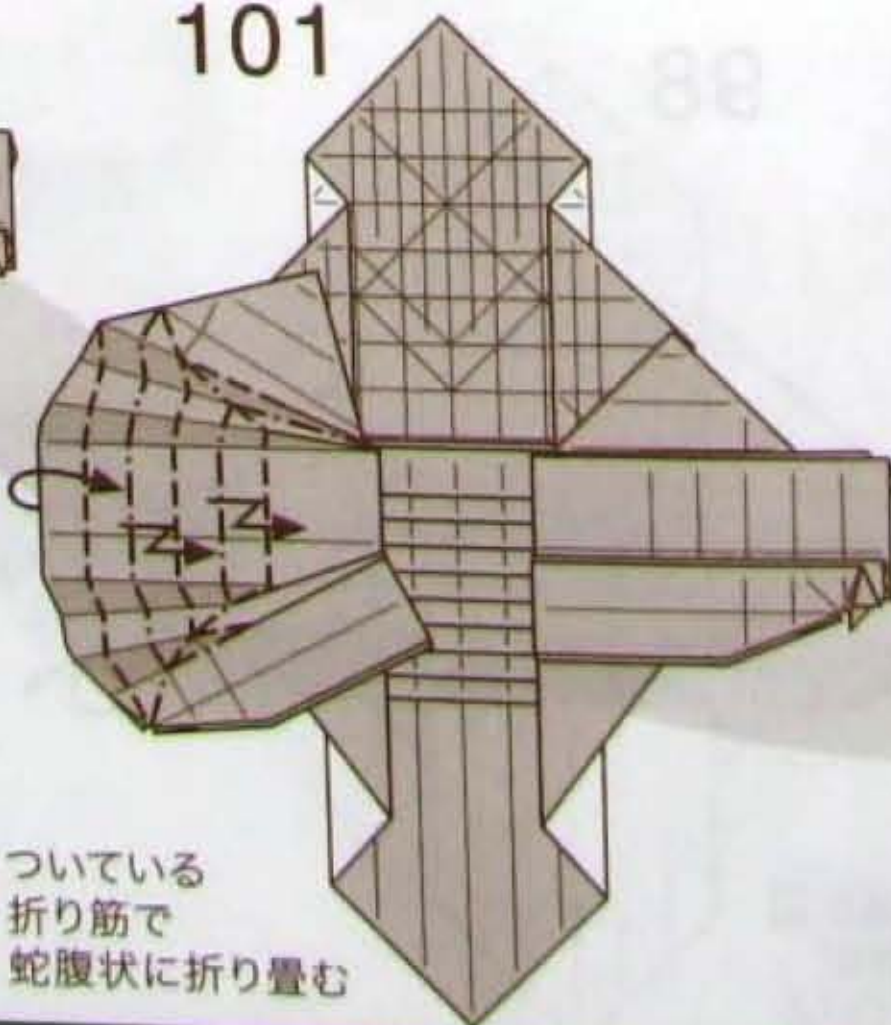

ついている折り筋で蛇腹状に折り畳む

102

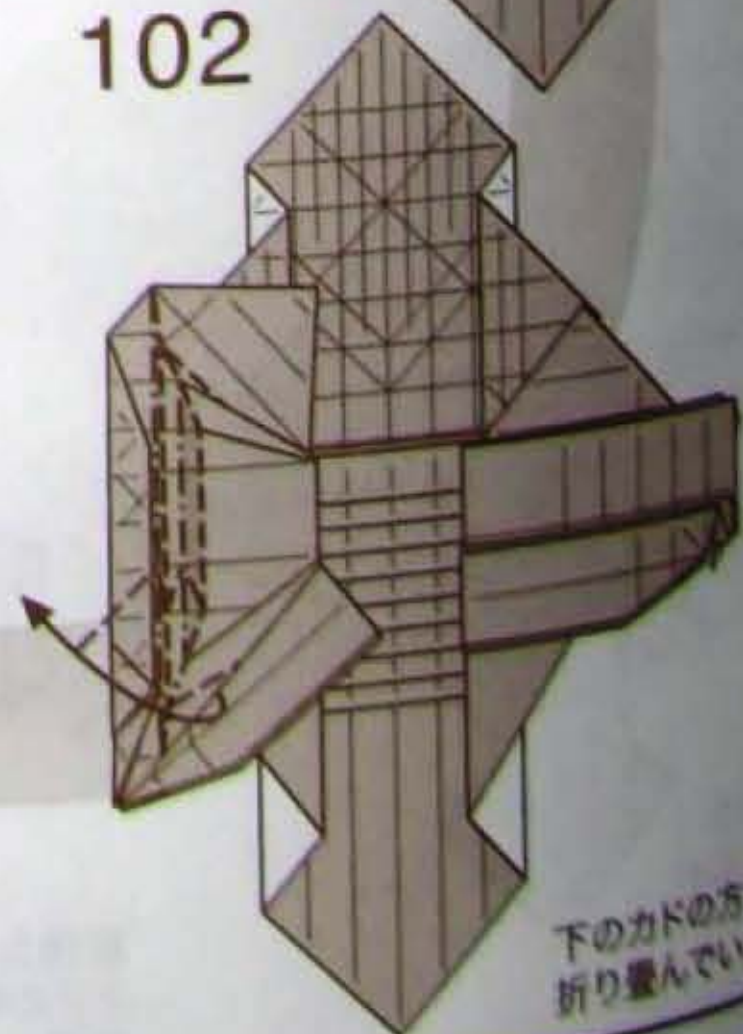

下のカドの方から折り畳んでいく

110

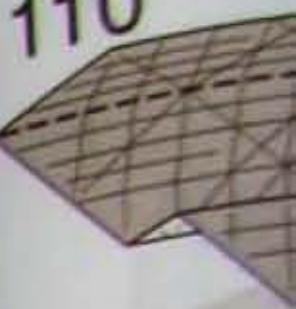

反対側のヒダも扇状になるよう

116

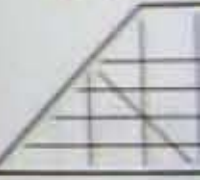

117



111

平らに折り畳む

112

軽く広げて
内側を見る

110

反対側のヒダも少し引き出して
調整するように調整する

113

内側を広げて
アミの部分
つぶすように折る

115

手前の1枚を
反対側へ折る

114

内側の紙を引き出す

116

アミの部分をつぶして
山折り線を出すように折り畳む

Japão Burajirujin
www.japaoburajirujin.blogspot.com

117

反対側も
115-116と
同様に折る

115-116

119

軽く広げる

118

戻す

の方から
でいく

129 ヒダを広げる

130 ついでに折り筋で段折りして平らに折り畳む

131 反対側も127-130と同様に折る

132 ヒダを広げる

133 山折りの折り筋をつける

134 アミのカドが次の図で平らにする部分

128 フチを反対側へ折る

127 カドを引き出す

126 反対側も122-125と同様に折る

125 カドを下へ折る

124 ついでに折り筋で続けて折り畳んでいく

123 ついでに折り筋で段折りして折り畳んでいく

122 カドをつまむように折る

121 平らに折り畳む

120 ついでに折り筋で両側で段折り

135 アミの... 平らに...

136

145

146 フチのところで折り筋をつける

147 かぶせ折る

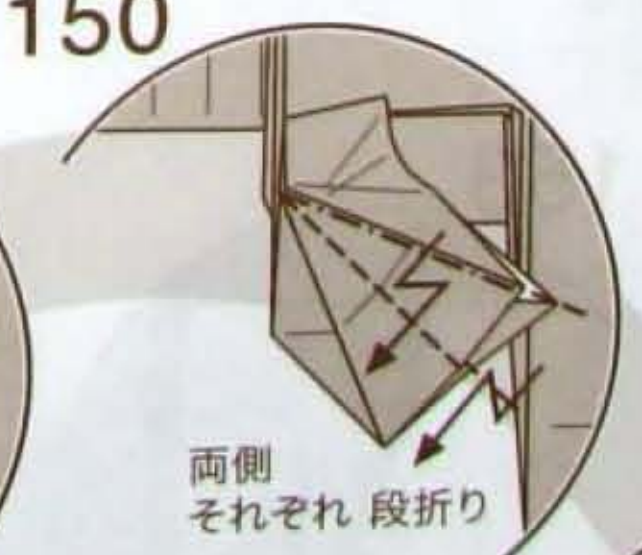
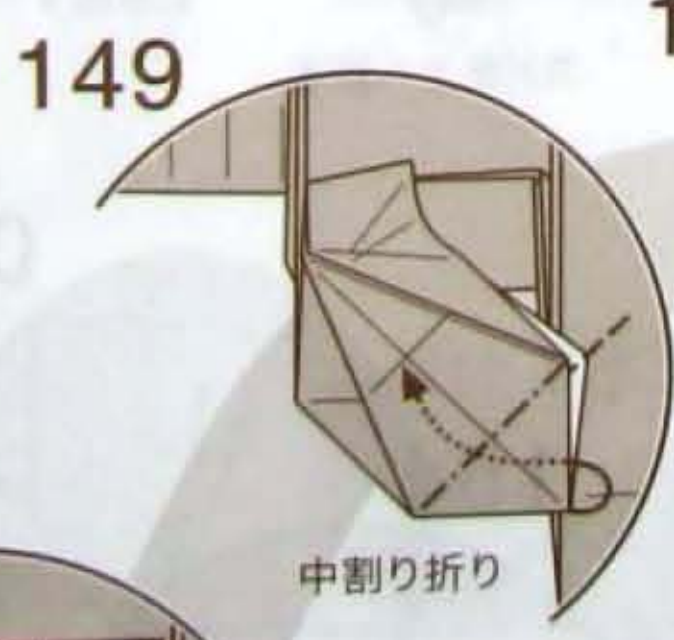
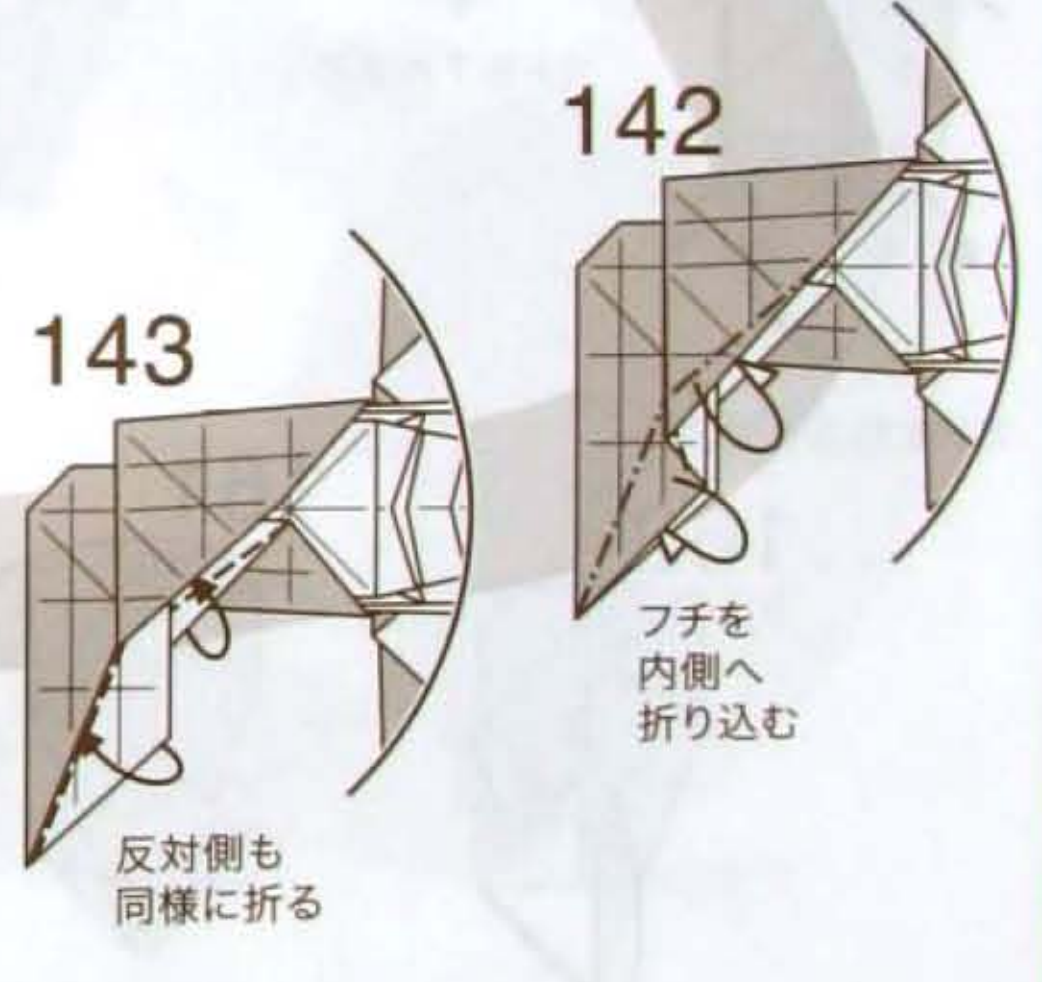
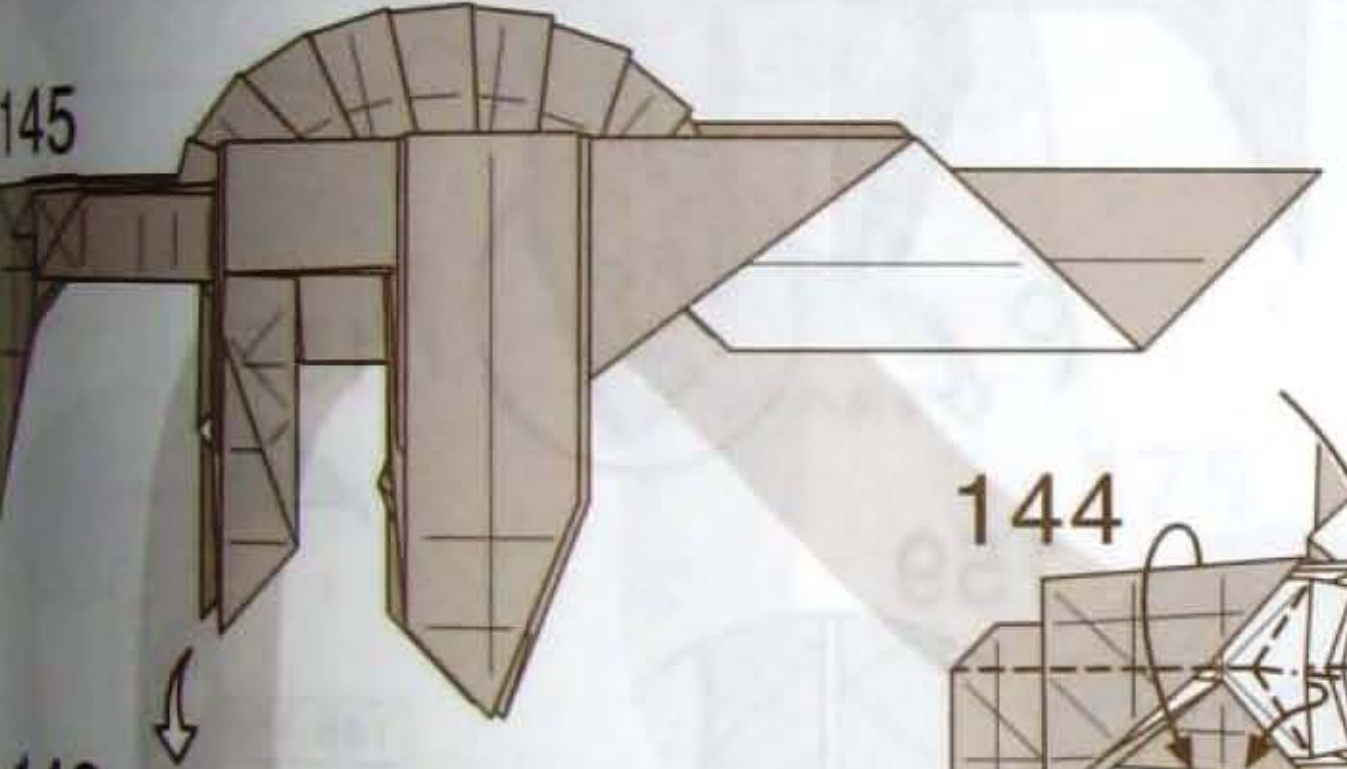
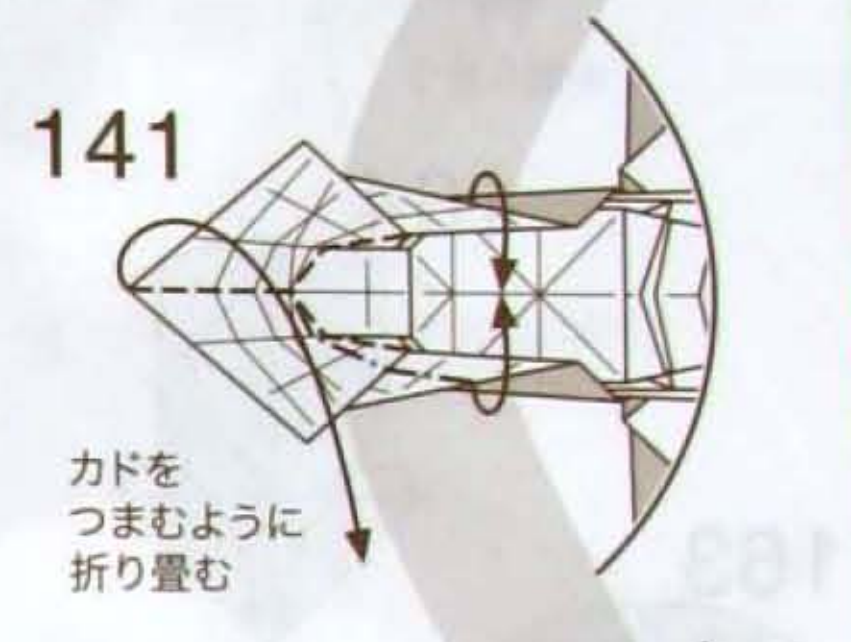
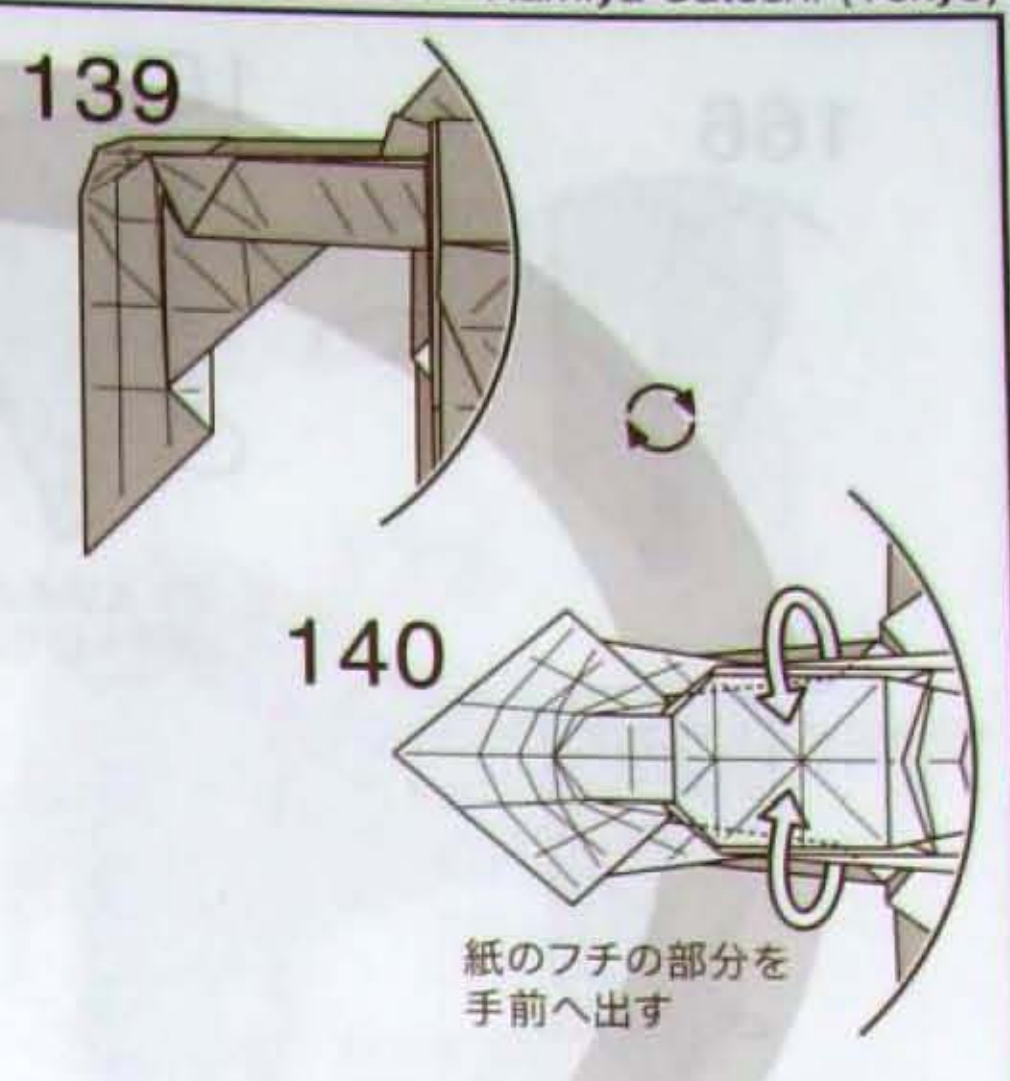
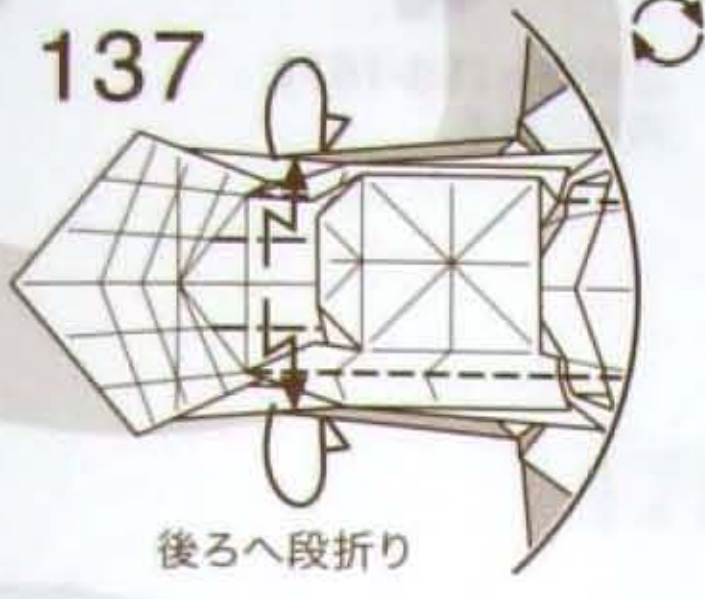
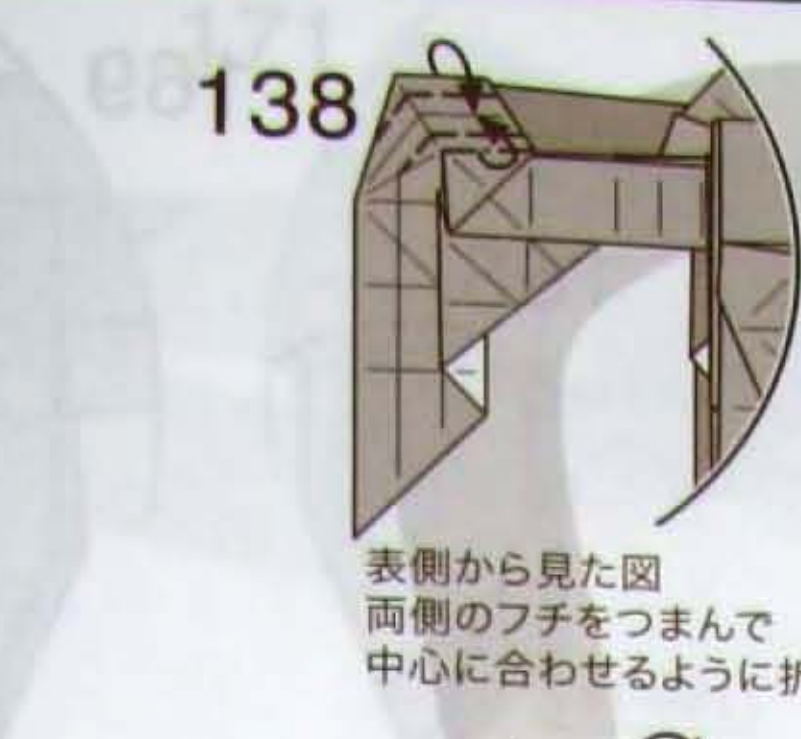
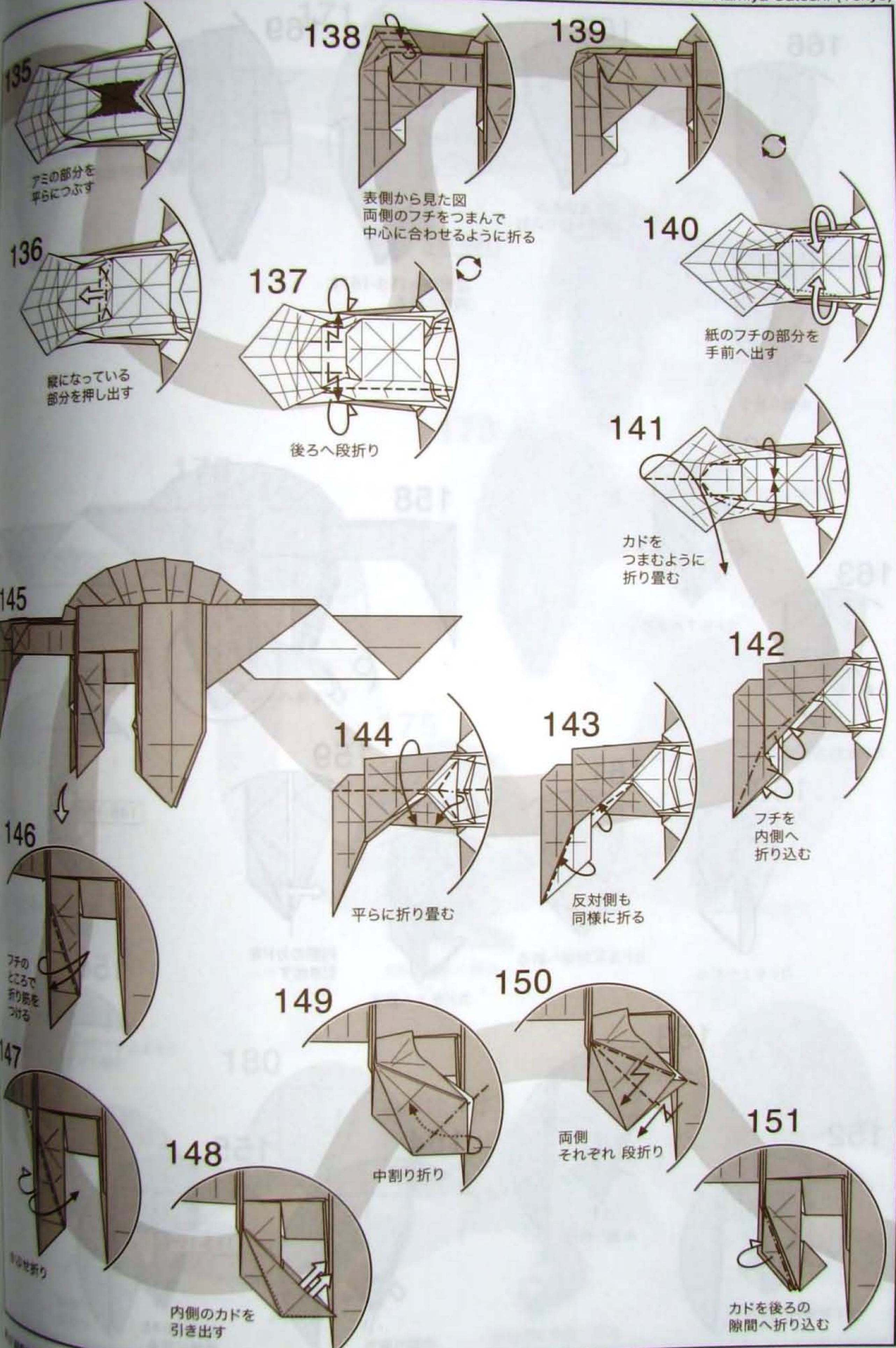

166

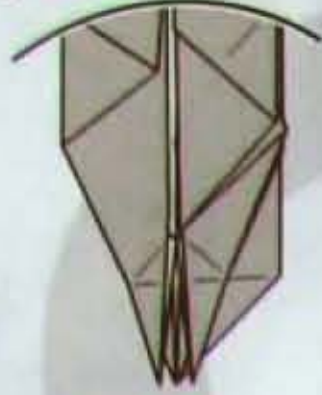

167



カドを後ろの隙間へ折り込む

168

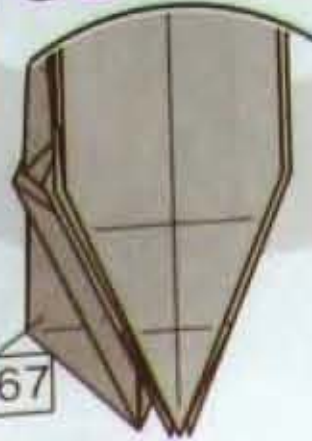

159-167と
同様に折る

169

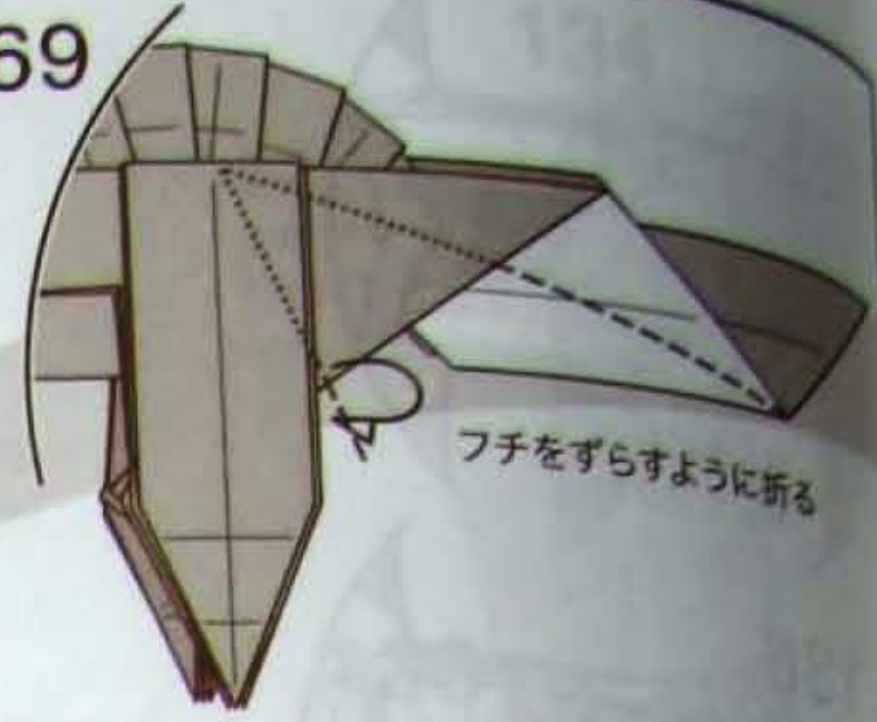

フチをずらすように折る

165

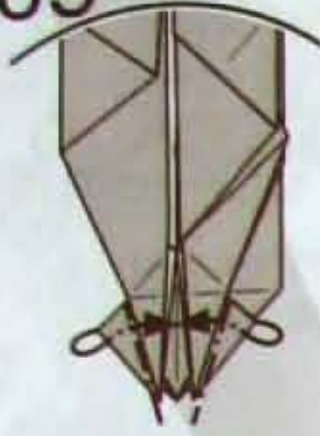

中割り折り

164

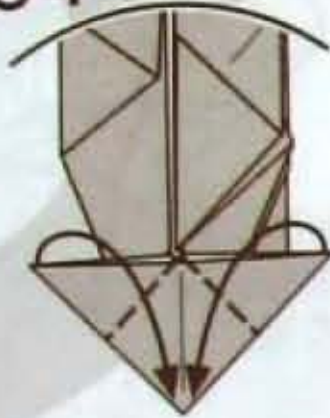

カドを下へ折る

163

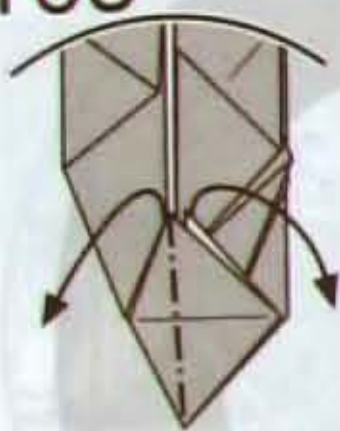

カドを左右へ広げる

158

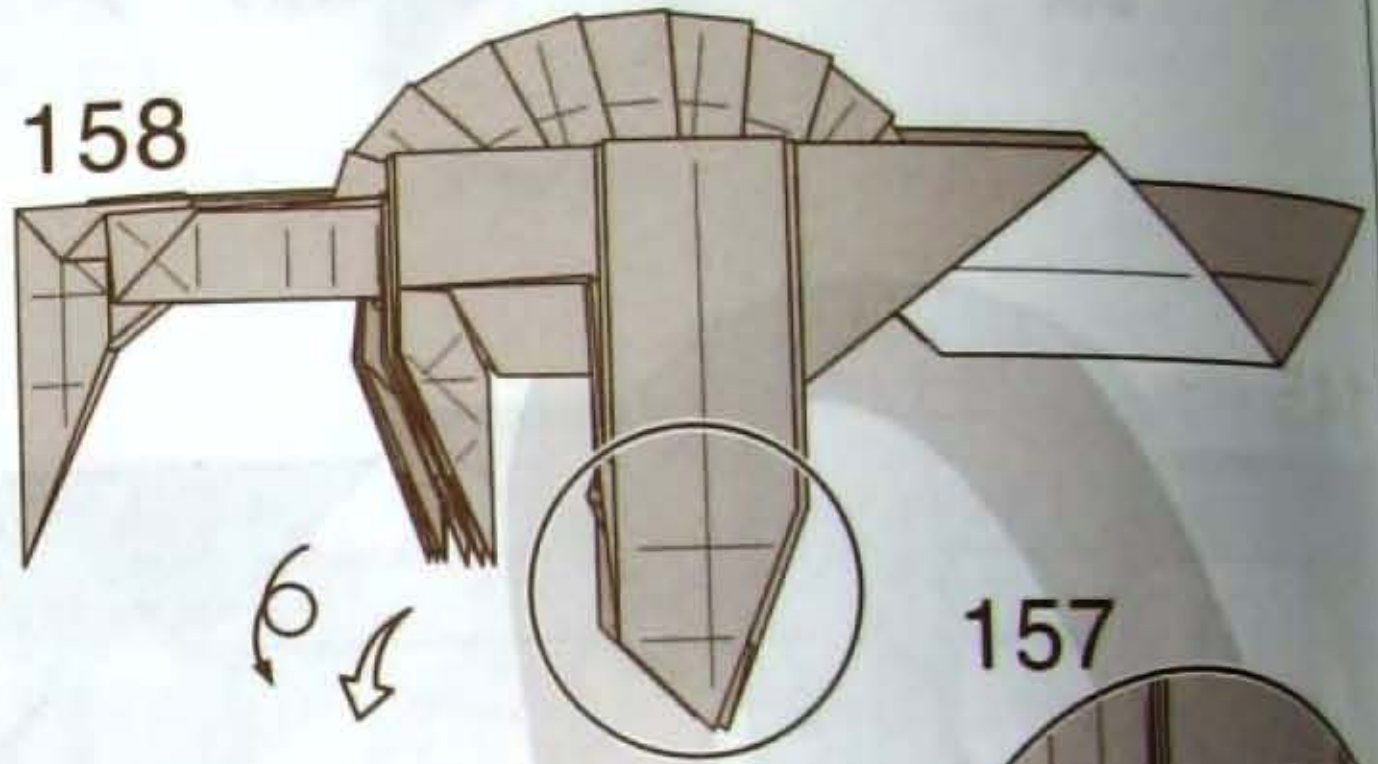

157

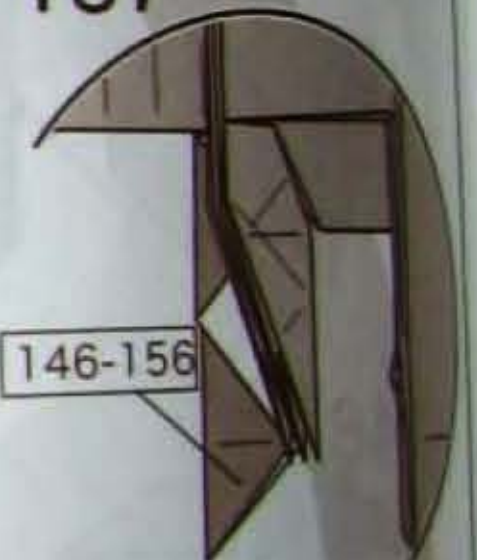

146-156

反対側も146-156と
同様に折る

162

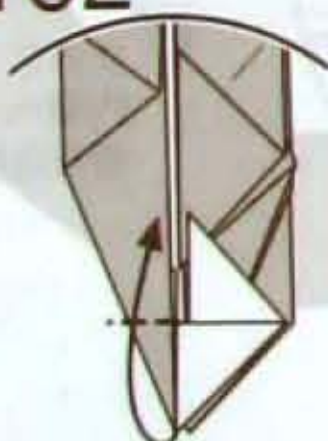

カドを上へ折る

161

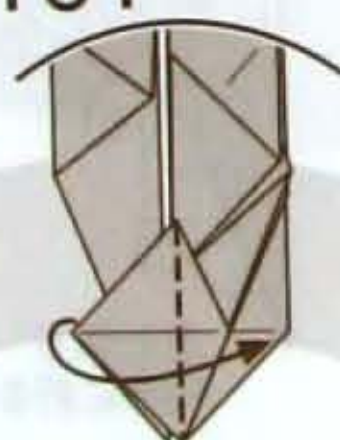

カドを反対側へ折る

160

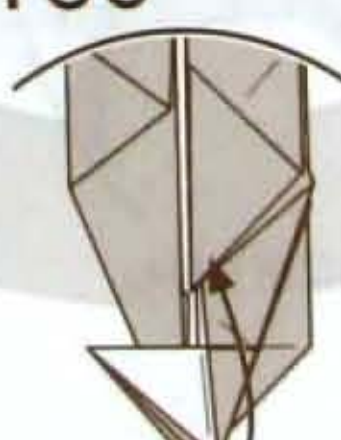

カドを上へ折る

159

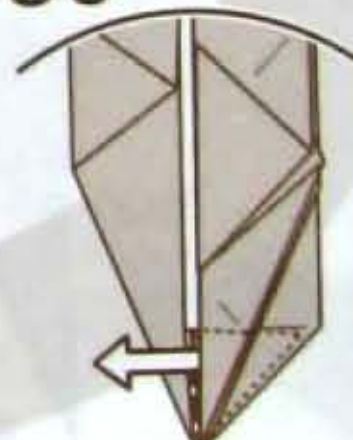

内側のカドを
引き出す

153

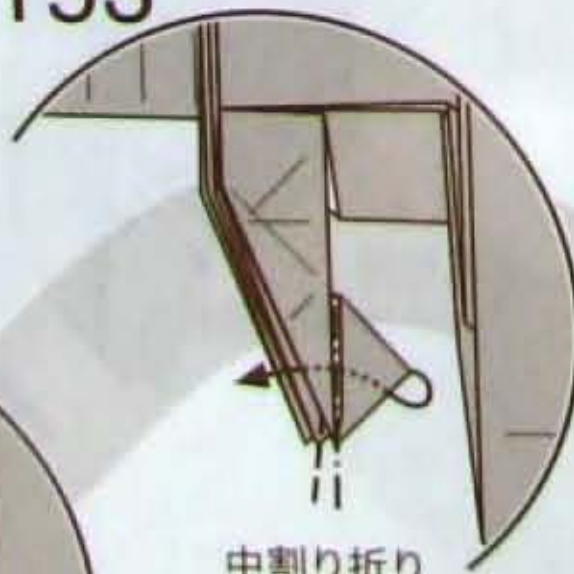

中割り折り

152

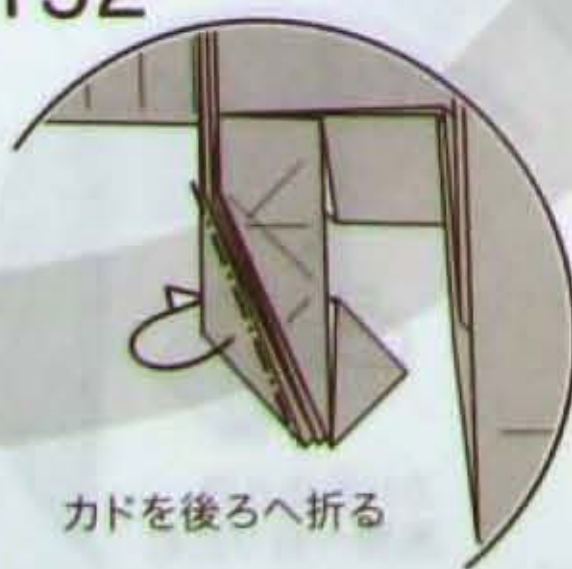

カドを後ろへ折る

154

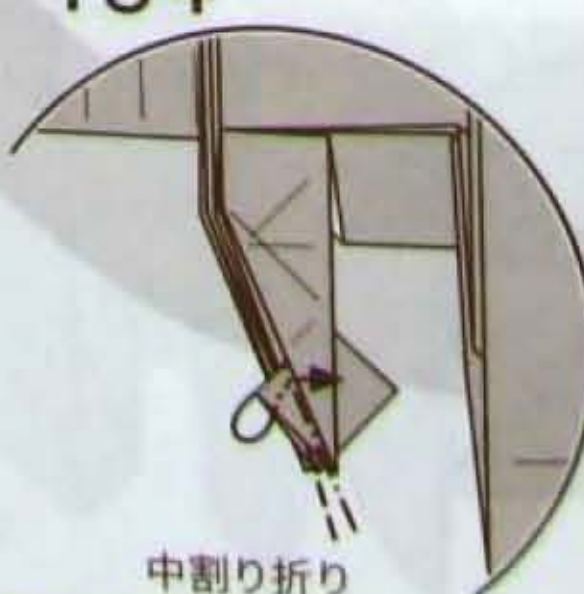

中割り折り

155

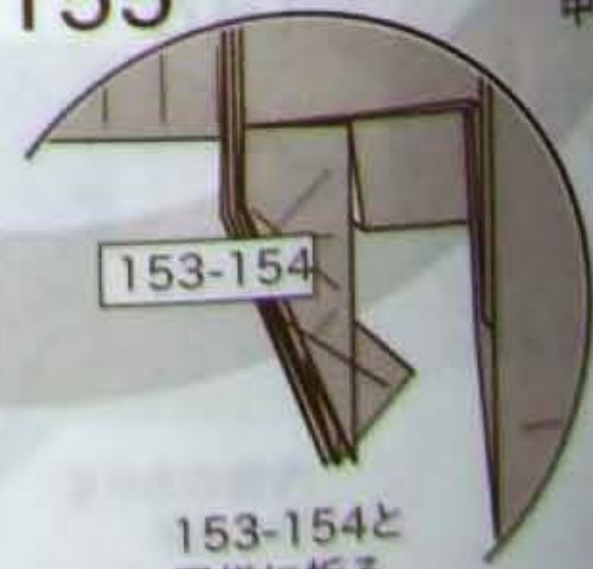

153-154と
同様に折る

中割り折り

170



177



○のところか
折り筋をつ

178



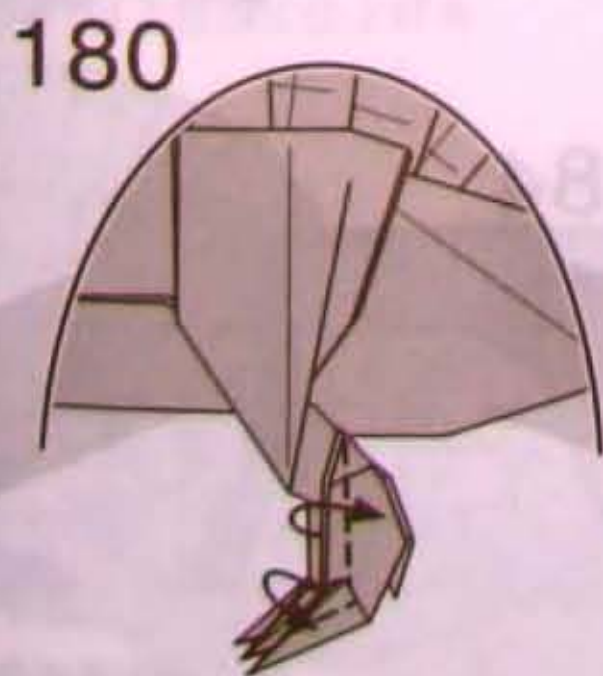
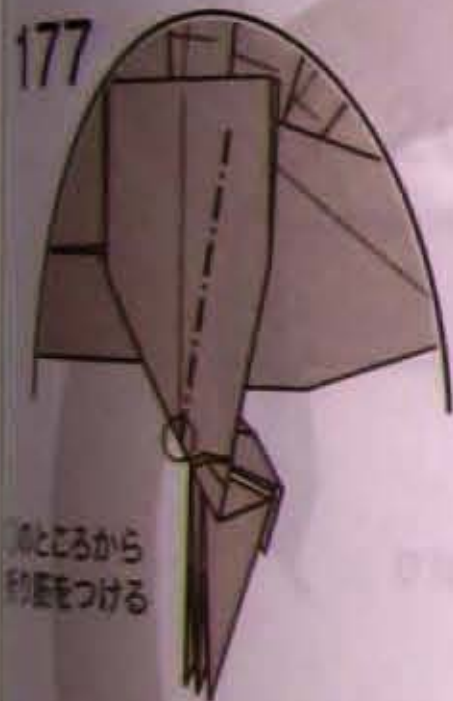
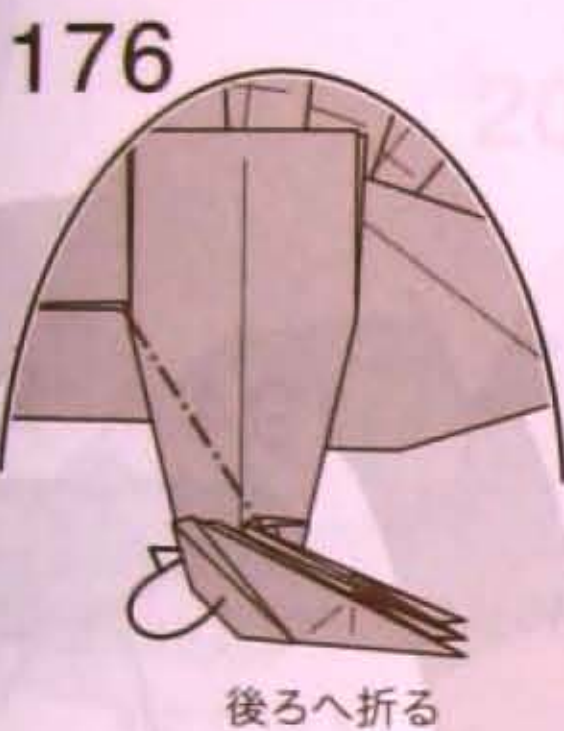
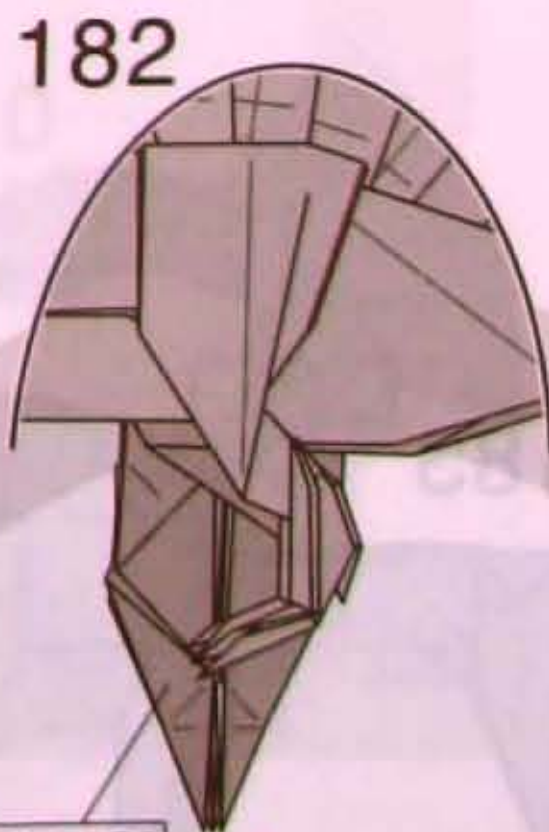
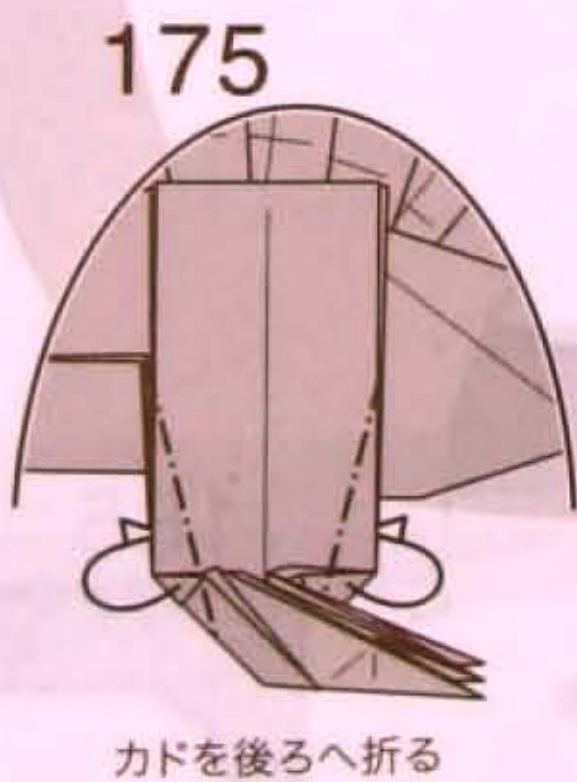
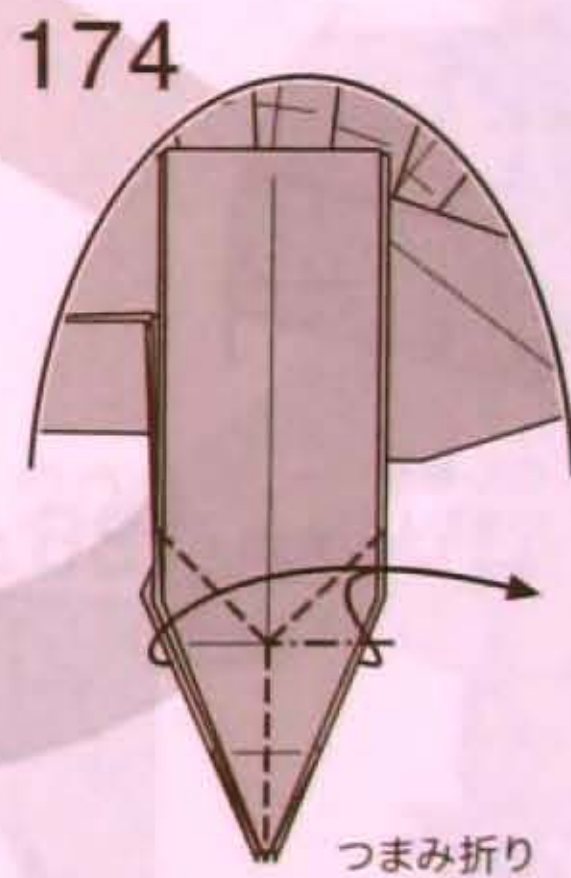
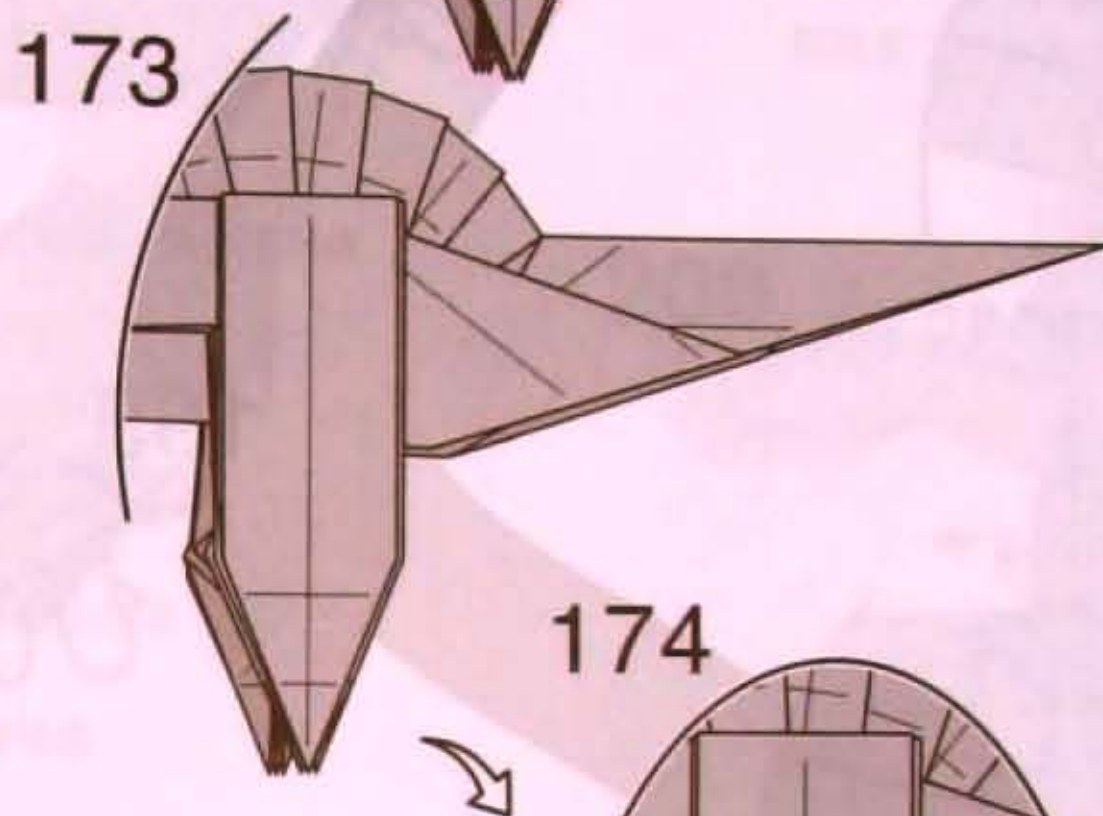
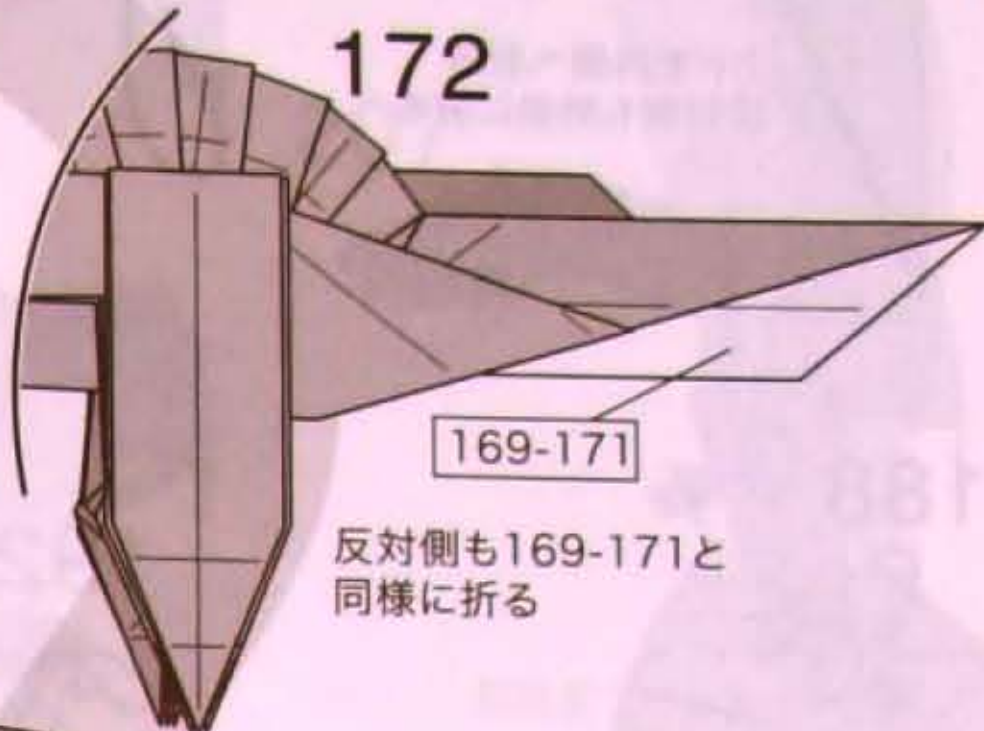
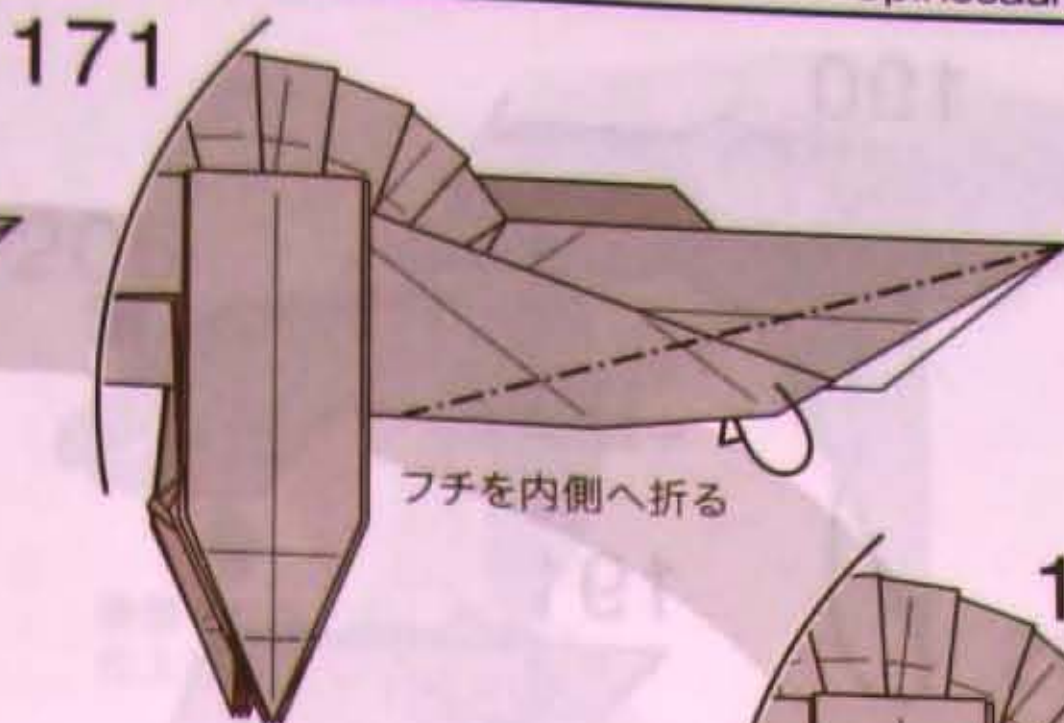
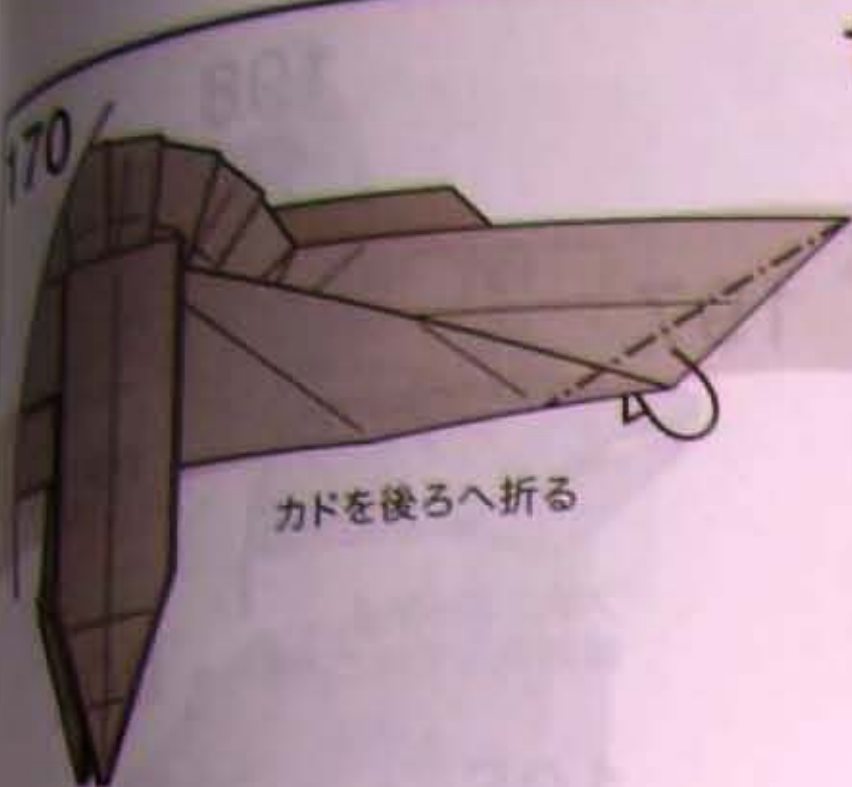

Japão Burajirujin

www.japaoburajirujin.blogspot.com

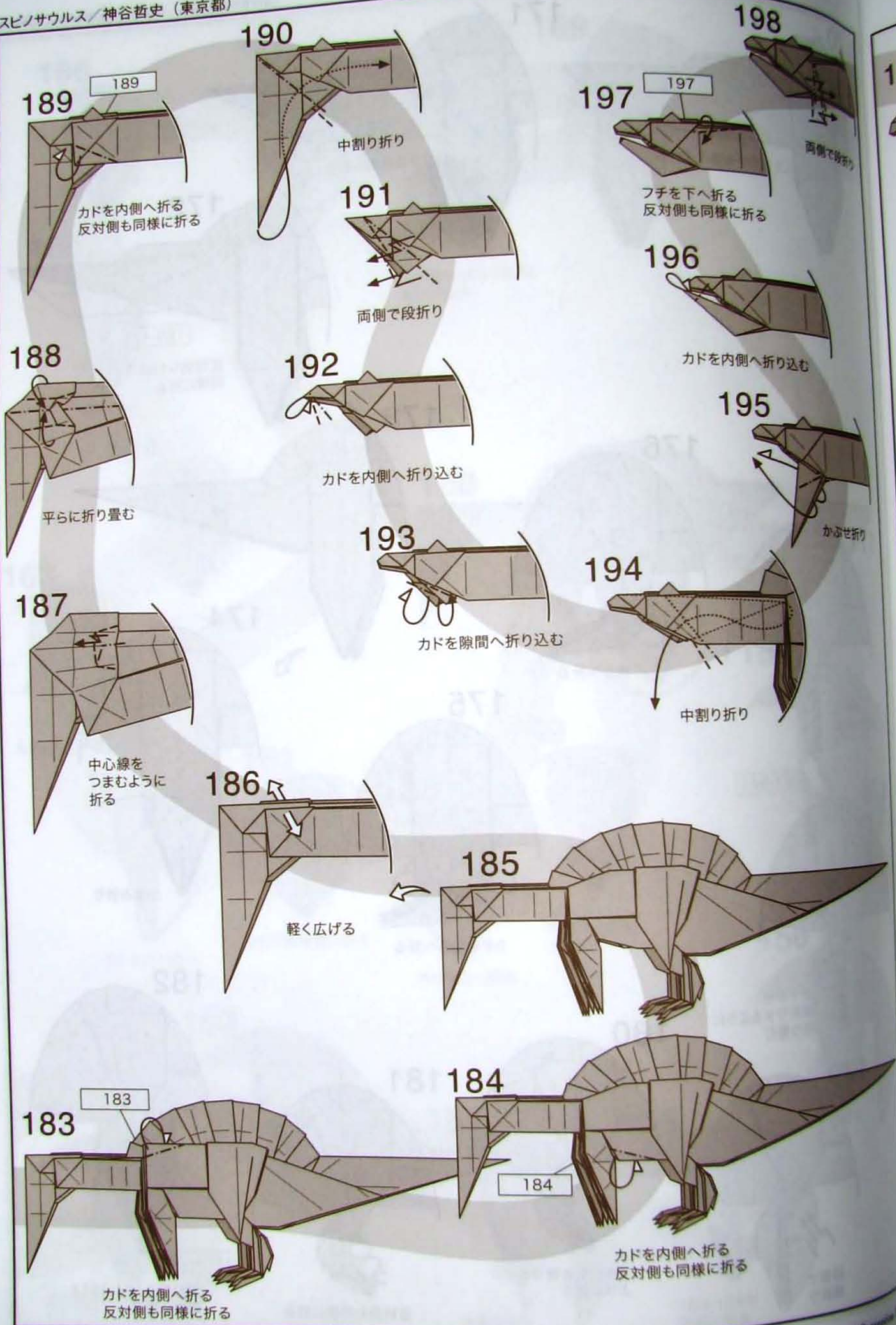



199

両側で段折り



200

内側へ
段折り



201

ふせ折り

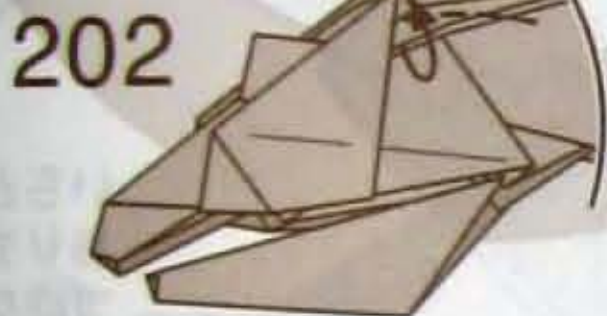

202

手前のフチを
上へ折る

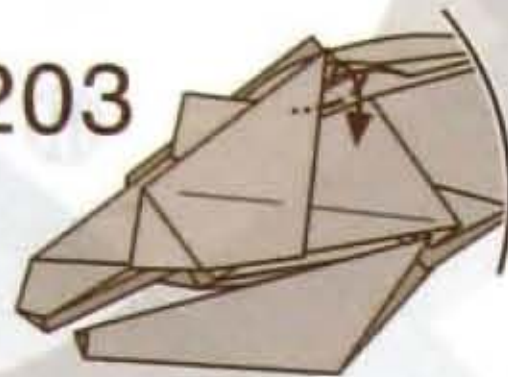

203

奥のフチを
広げて目を作る

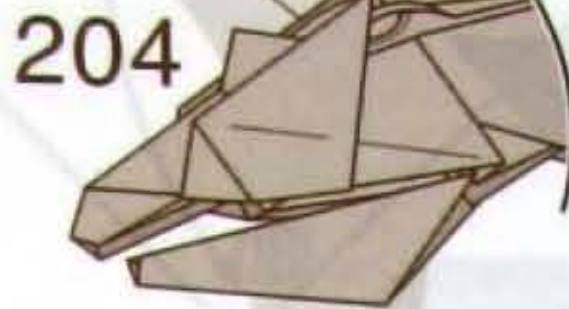

204

反対側も202-203と
同様に折る



205

頭部を立体的に
仕上げる

202-203



206

207

前肢をつまむように折る



208

後ろのカドを
段折り

209

手前のカドを
段折り

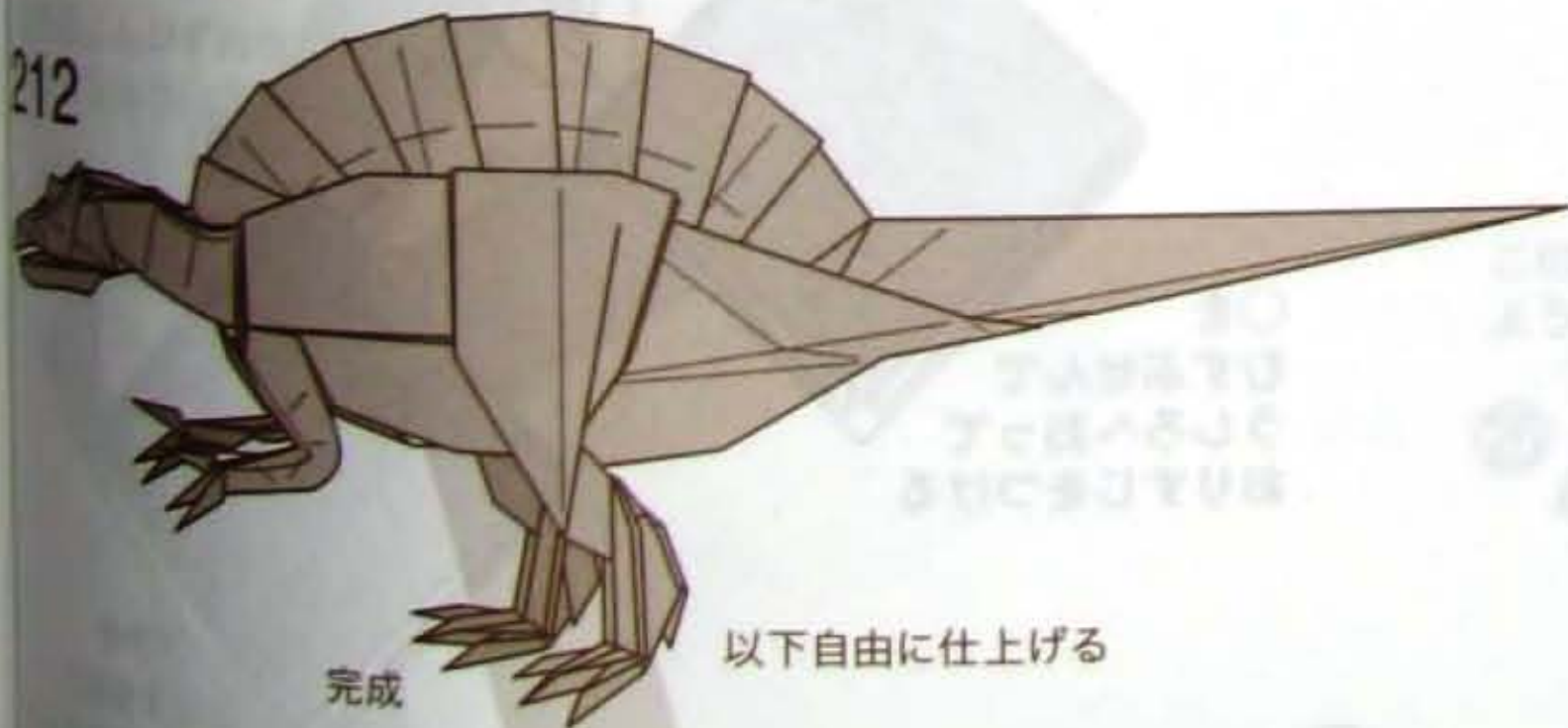

210

完成

以下自由に仕上げる

211

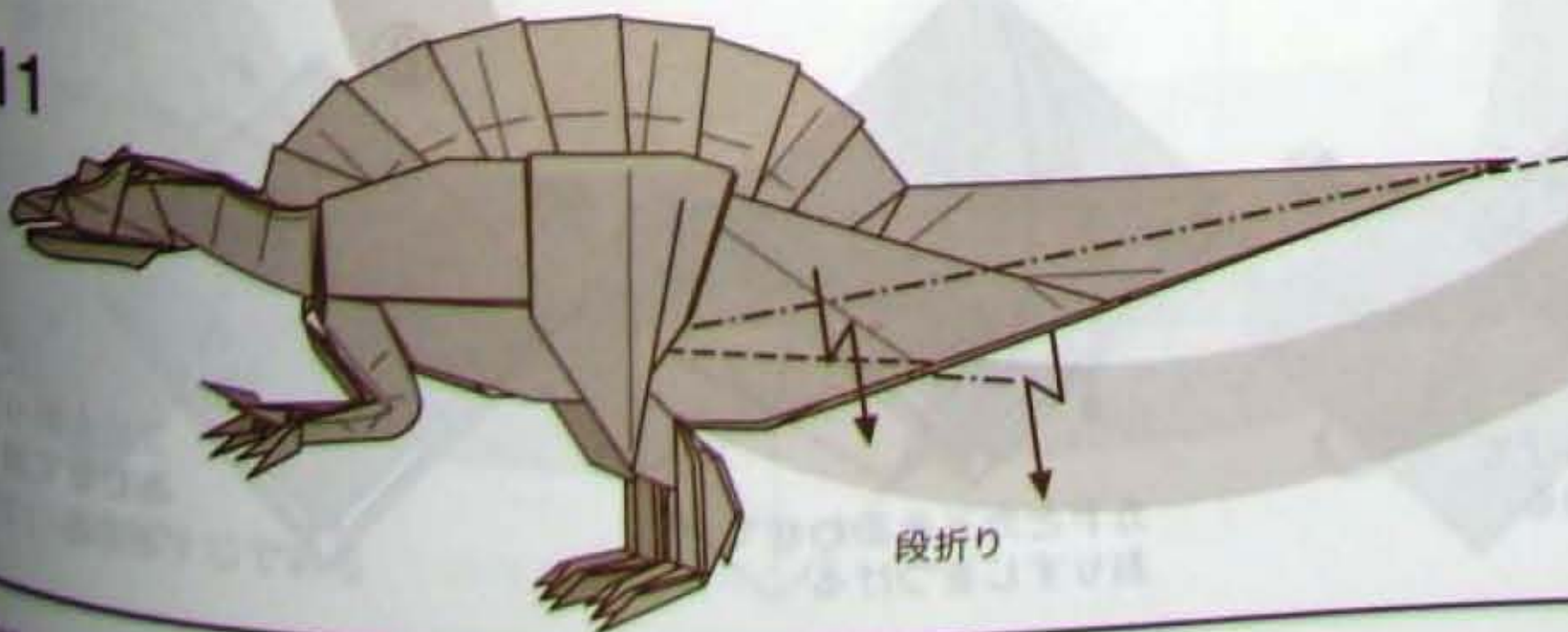

段折り

210

207-209

反対側も207-209と
同様に折る

Makoto Rose

Yamaguchi Makoto

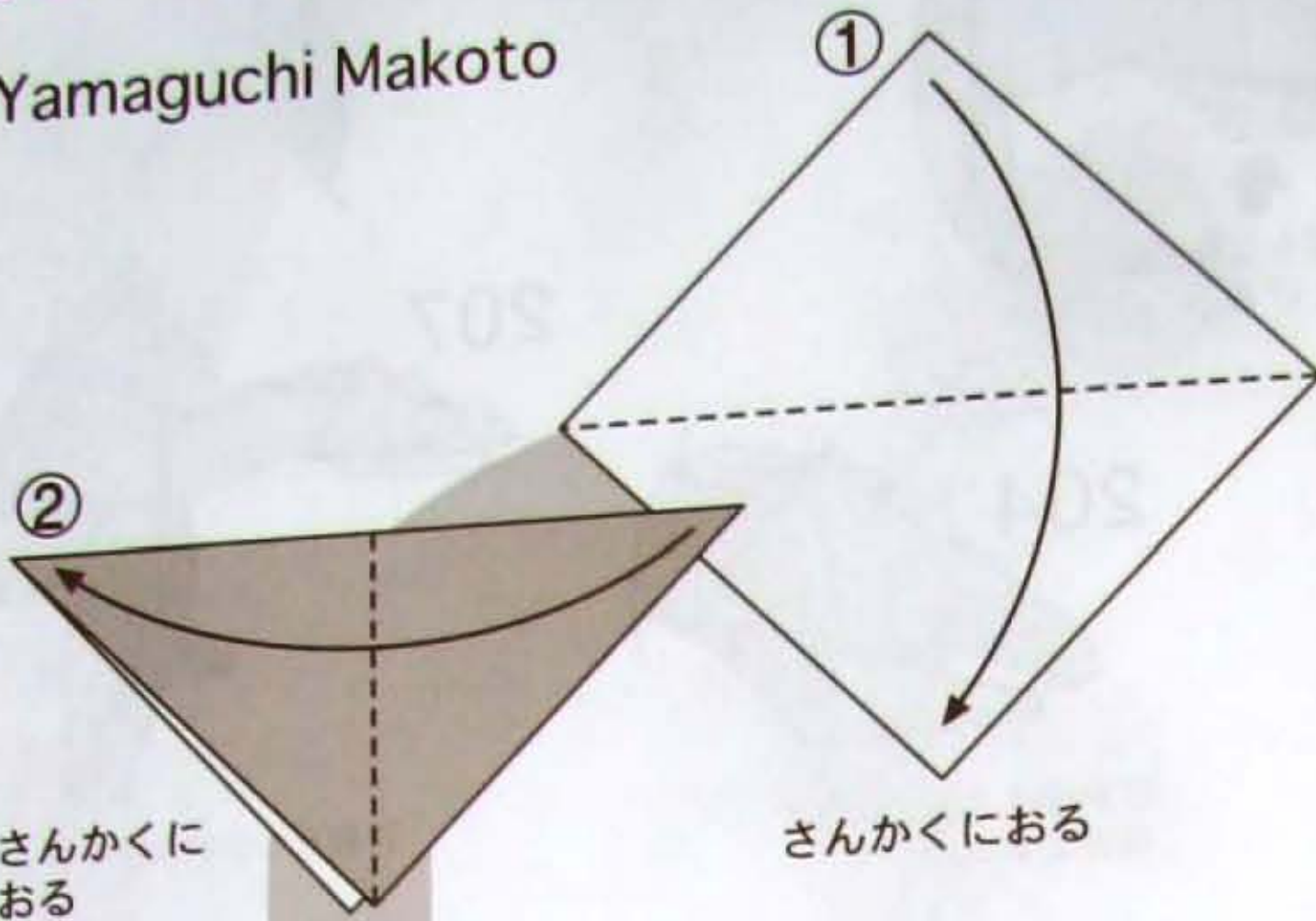

さんかくにおる

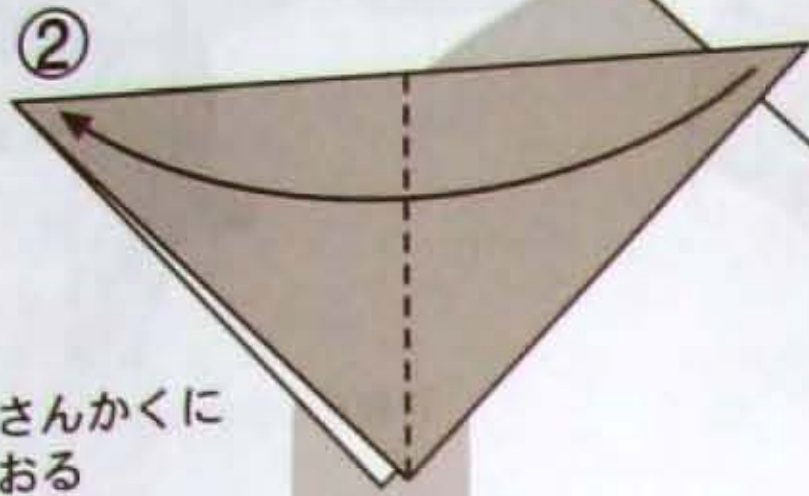

さんかくにおる

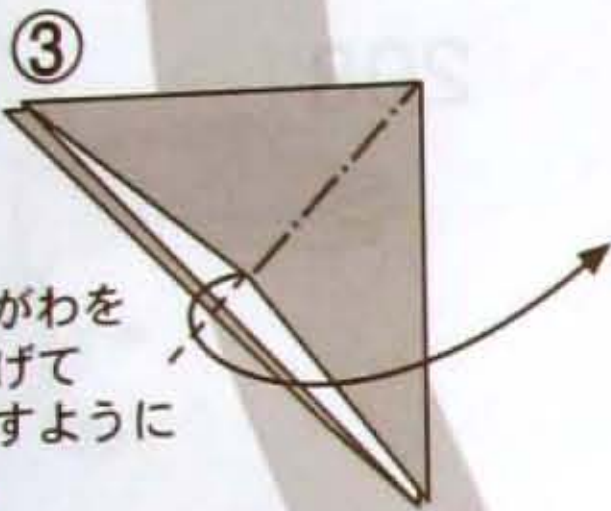

うちがわをひろげてつぶすようにおる

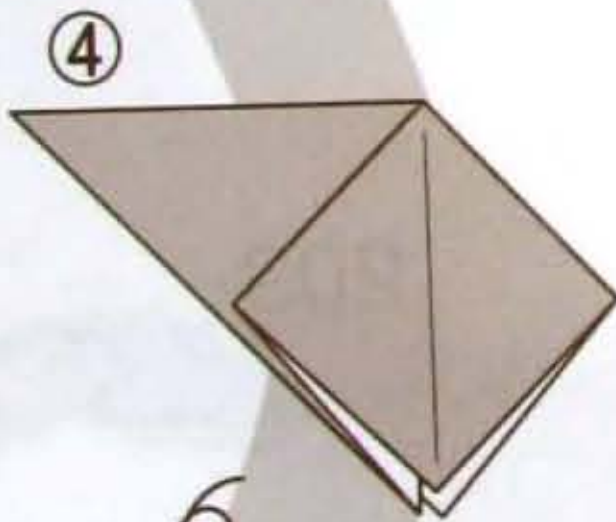

4

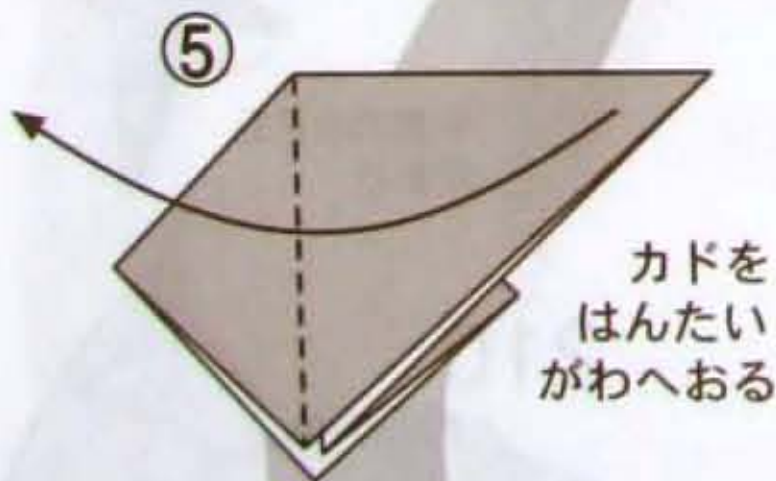

カドをはんたいがわへおる

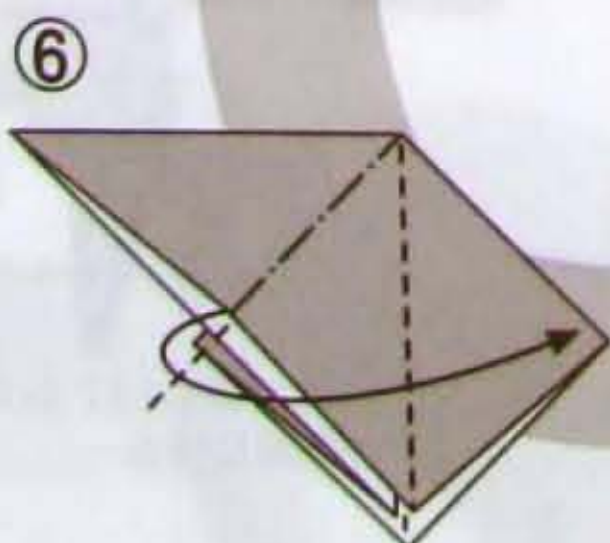

6

うちがわをひろげてつぶすようにおる

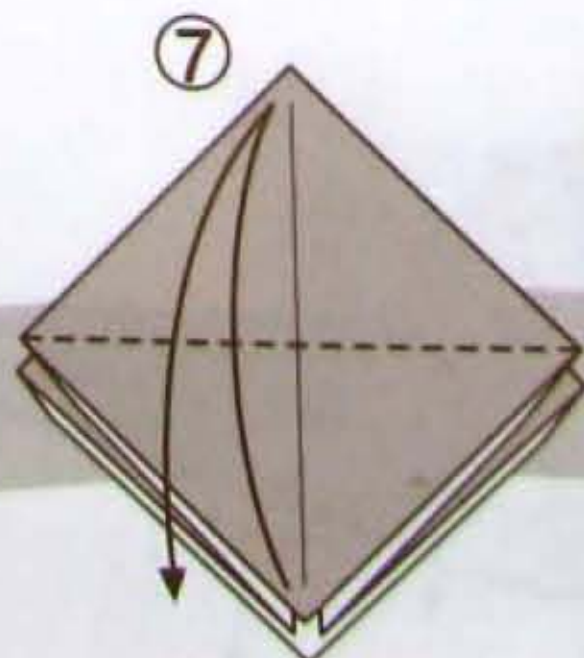

7

カドとカドをあわせておりすじをつける

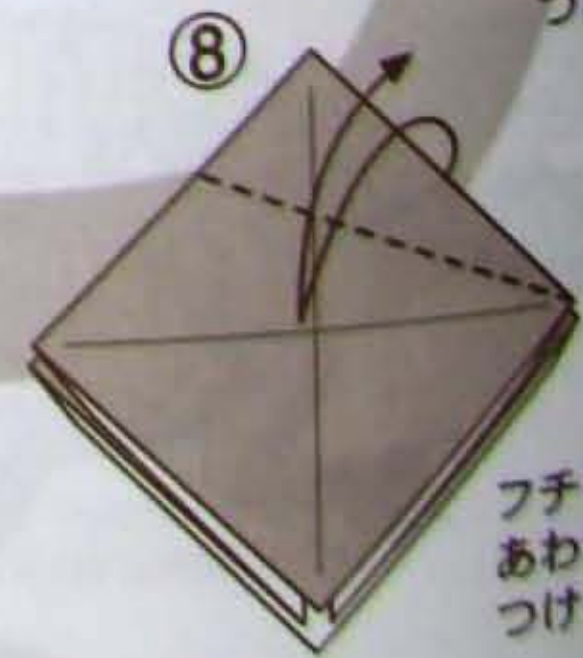

8

フチをおりすじにあわせておりすじをつける

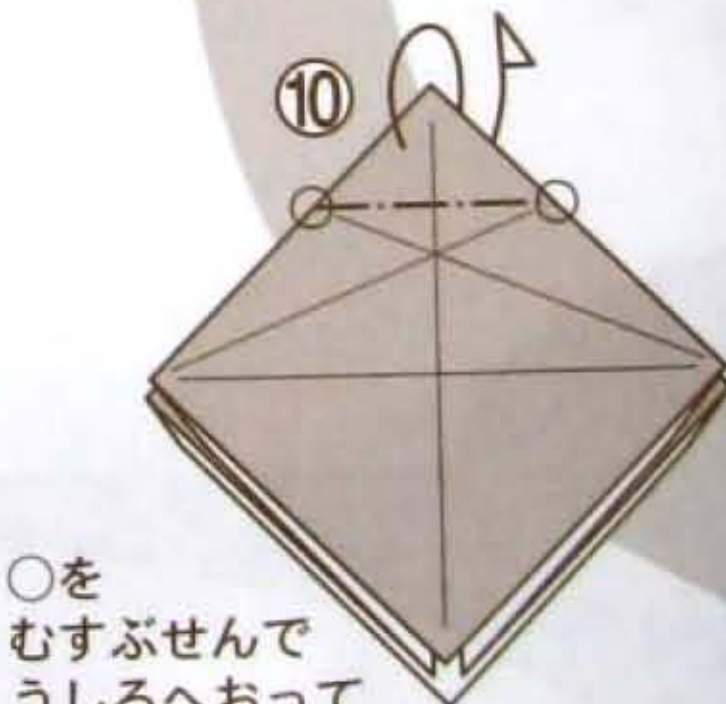

9

フチをおりすじにあわせておりすじをつける

のぶぶんをしずめるようにおる

○をむすぶせんでうしろへおっておりすじをつける

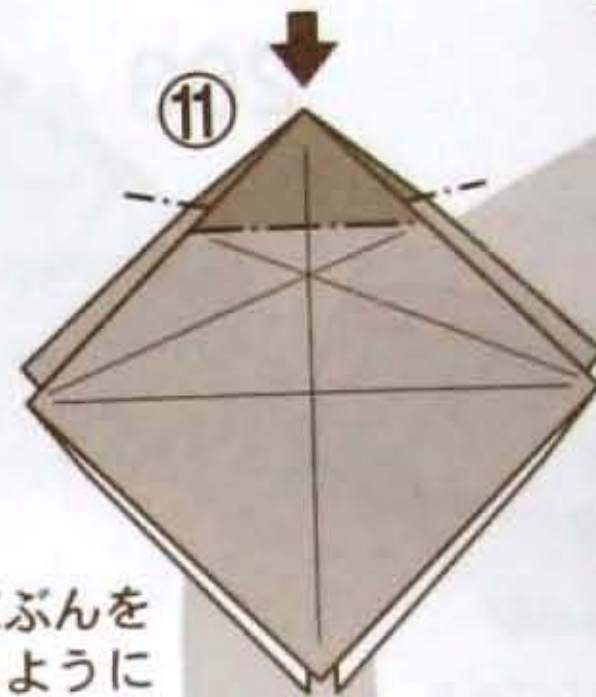

10

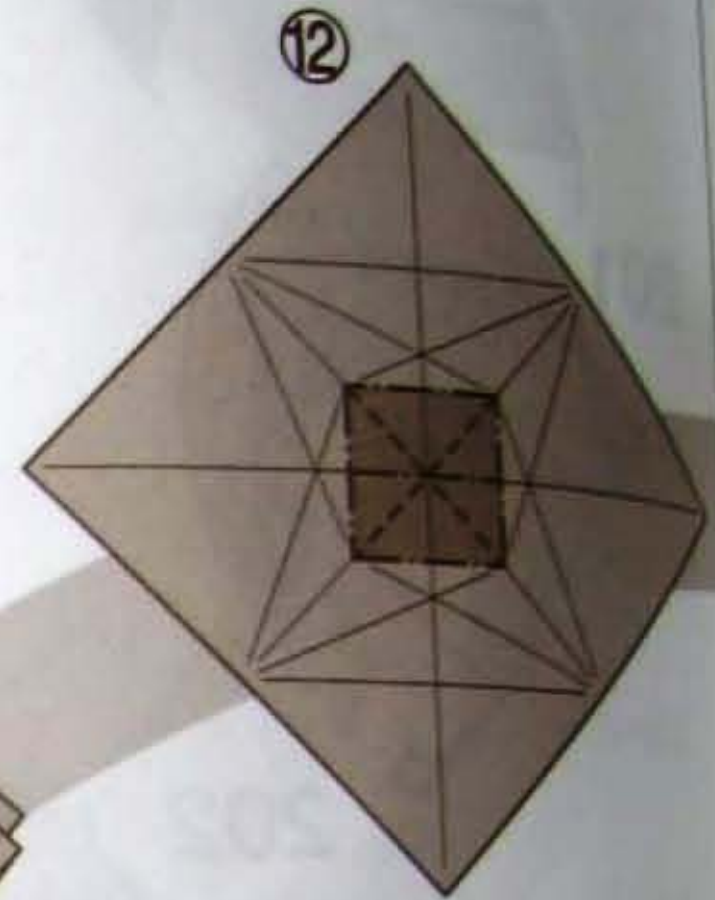

11

いちどぜんぶひろげておりすじをずのようにつけなおす



12

このぶぶのようにち



13

はん



14



15

つ

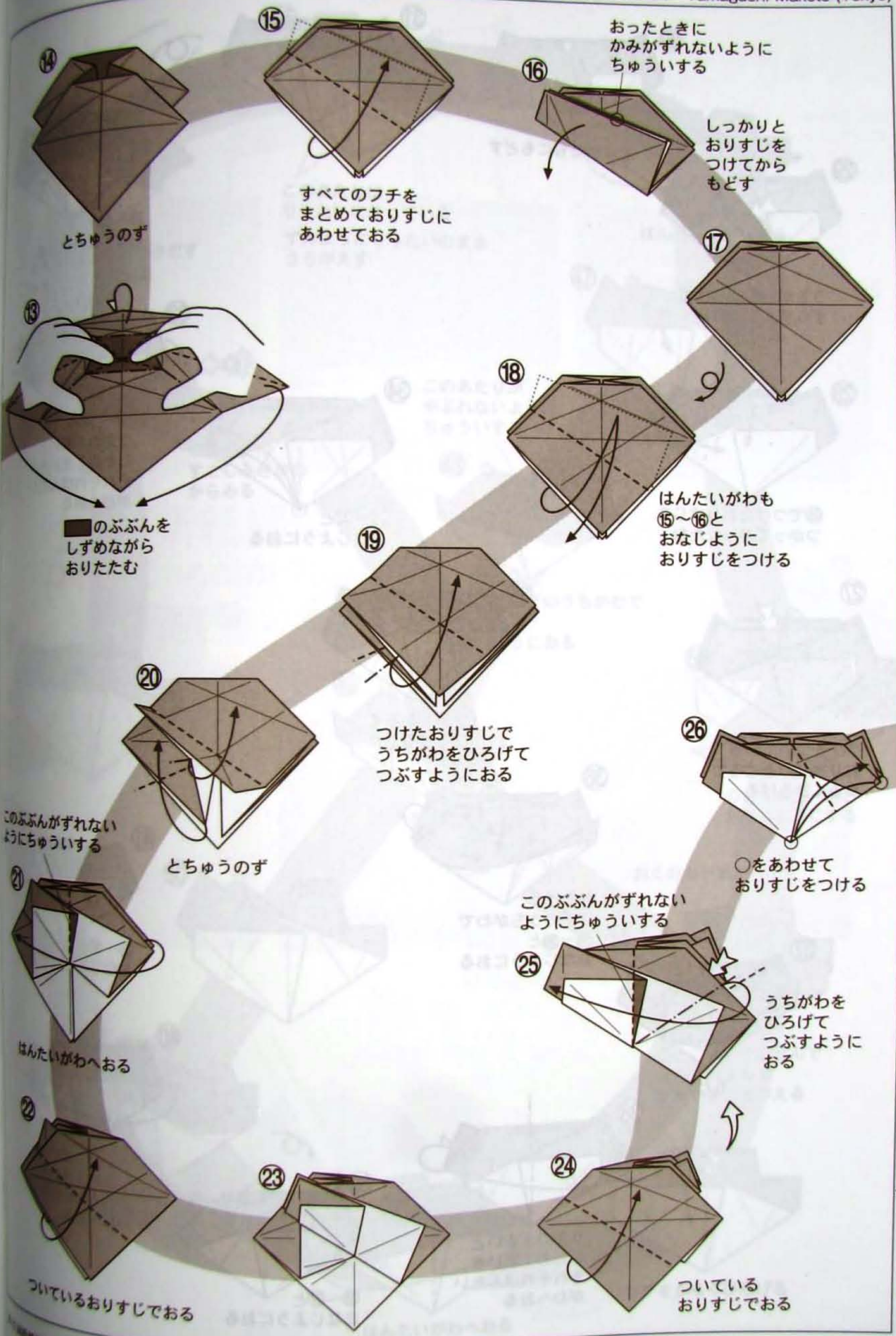

26のかたちにもどす

26~30とおなじようにおる

うかがわをひろげて
ずらすようにおる

26~32と
おなじようにおる

26でつけたおりすじを
つかっておりたたむ

26~32と
おなじようにおる

フチをかるく
ひろげる

ひろげた
フチのうちがわで
28~29と
おなじようにおる

35~37と
おなじようにおる

もどす

うへの1まいと
したの1まいを
それぞれはんたい
がわへおる

35~37と
おなじようにおる

うへの1まいと
したの1まいを
それぞれはんたい
がわへおる

35~37と
おなじようにおる

42

43

44

うかが
ひきだ
りった



44
うちがわのかみをひきだす
ひきだしたぶんは
りったいになる

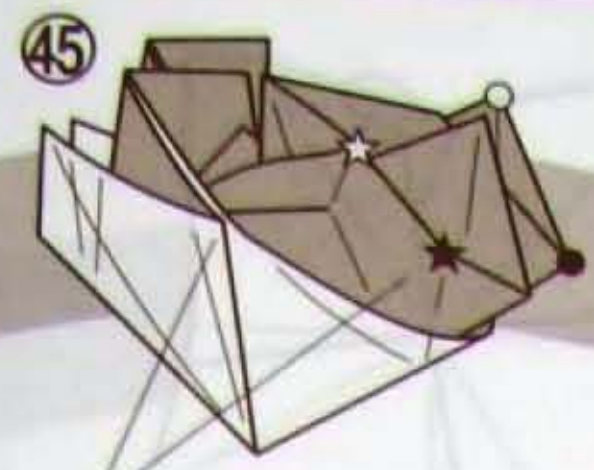

45
このあたりは
りったいになっている
ずのようにりったいのまま
うらがえす

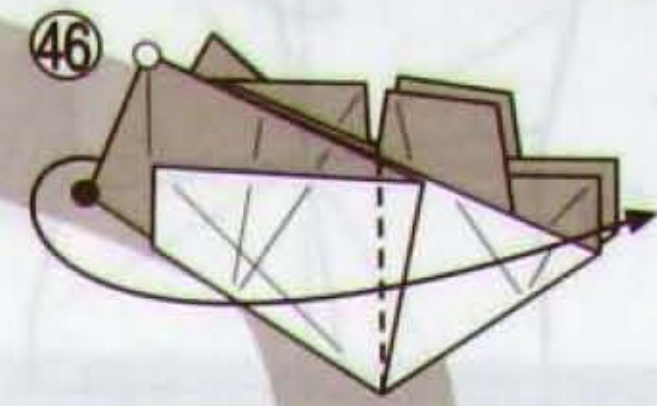

46
はんたいがわへおる

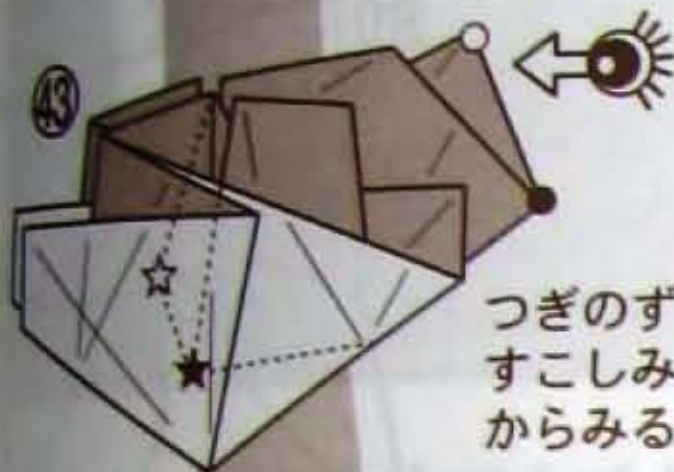

48
つぎのずは
すこしみぎがわ
からみる

このあたりが
やぶれないように
ちゅういする

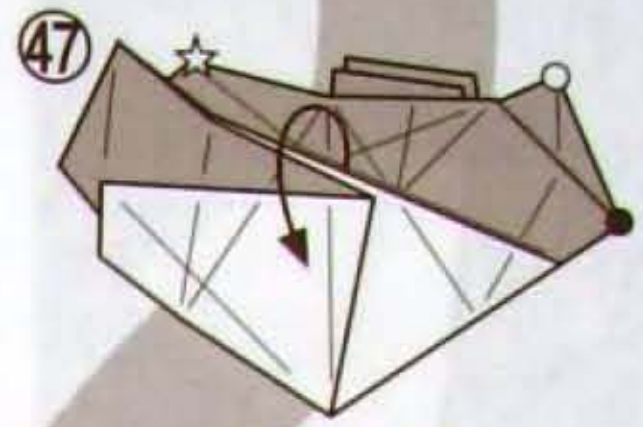

47
フチをかるく
ひろげる

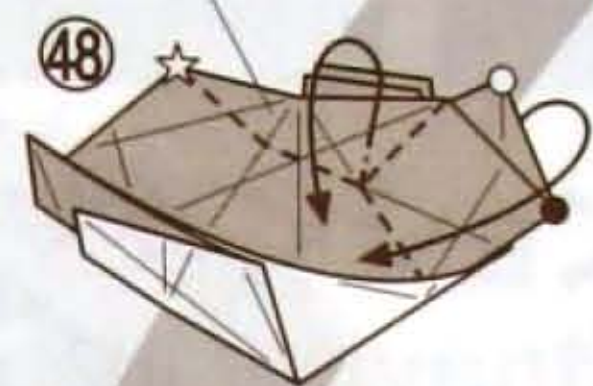

48
ひろげたフチのうちがわで
29~31と
おなじようにおる

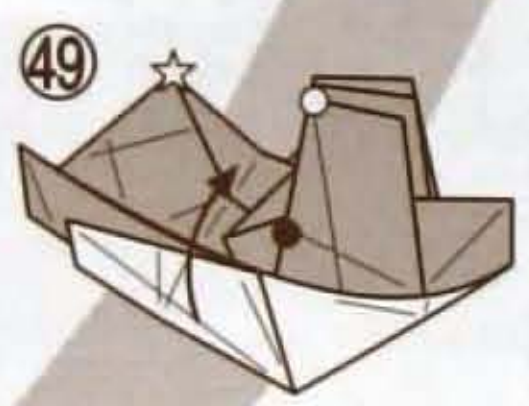
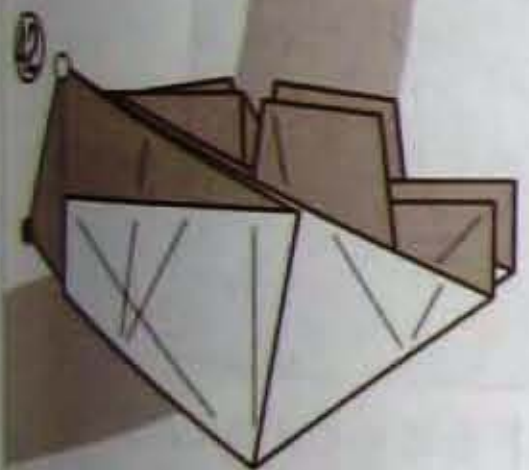

49
フチをもどす

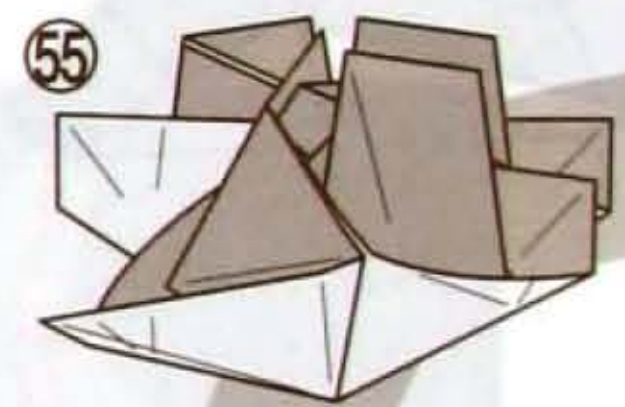

55
のこりも33~34と
おなじようにする

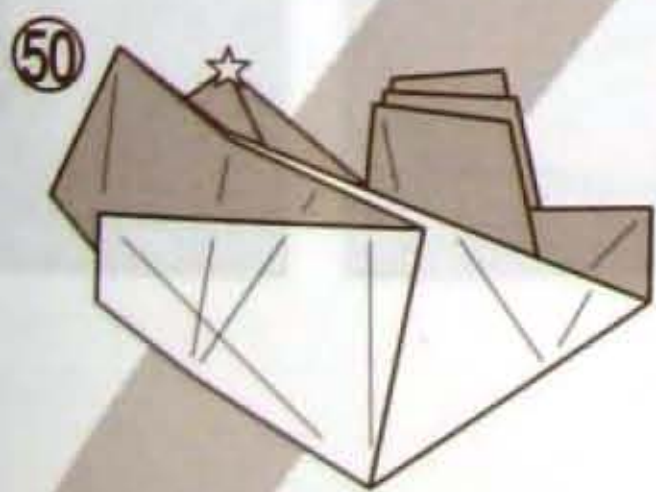

おくのカドまで

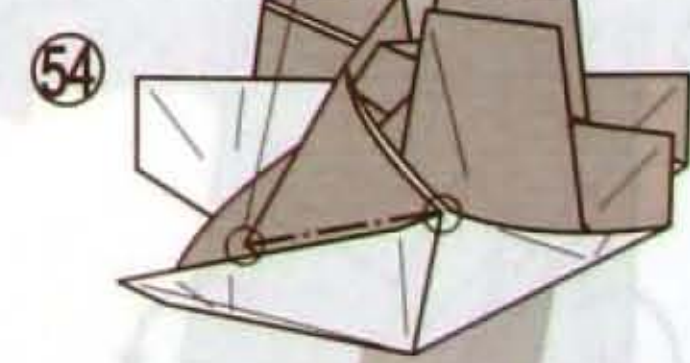

54
○と○をむすぶせんで
かるくつまんで
かたちをととのえる

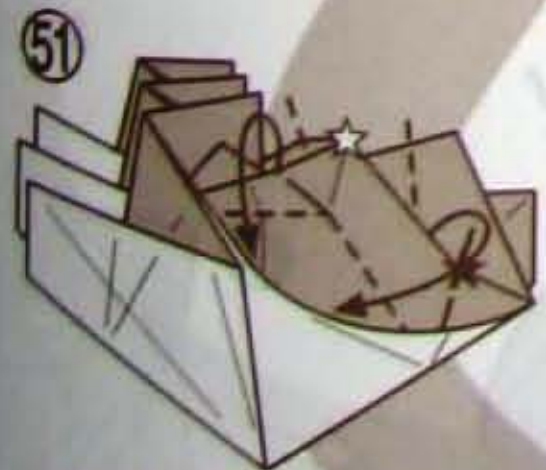

51
ついているおりすじで
33のかたちにおりこむ

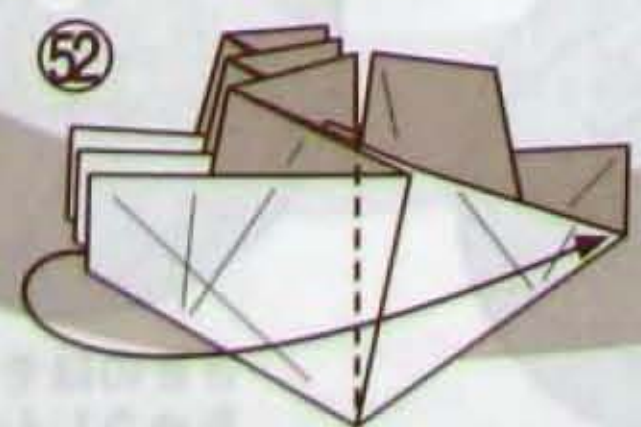

52
はんたいがわへおる

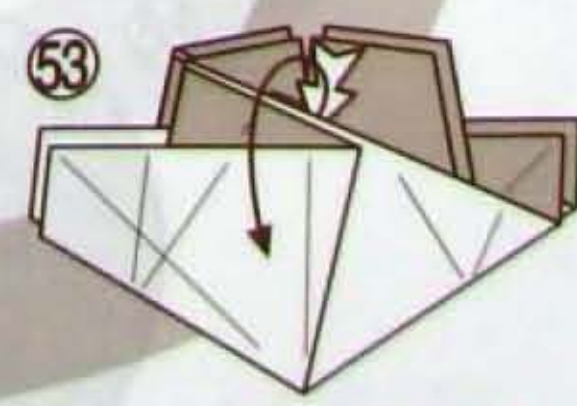

53
フチをかるくひろげる

58

ついている
おりすじを
つまんでずらす
ようにおる

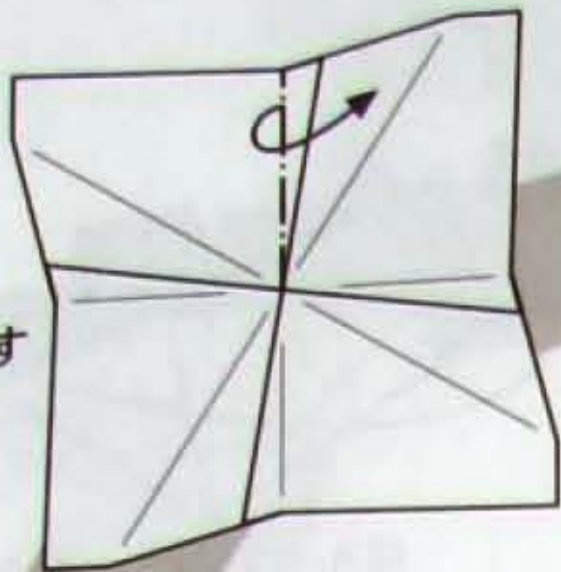

59

カドをうしろに
おりこんでとめる

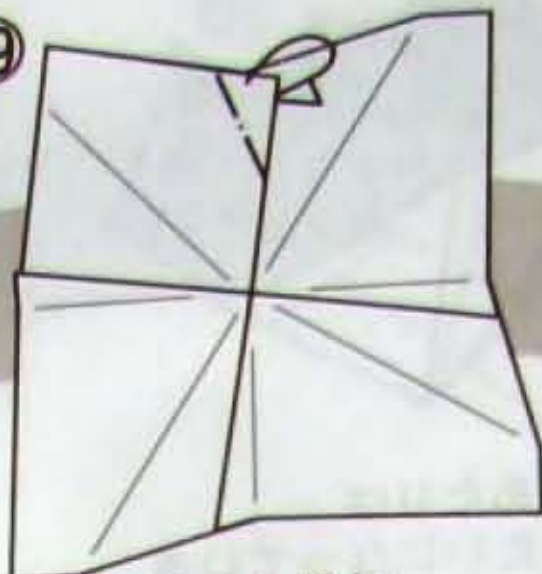

60

のこり3かしょも
58~59とおなじようにおる

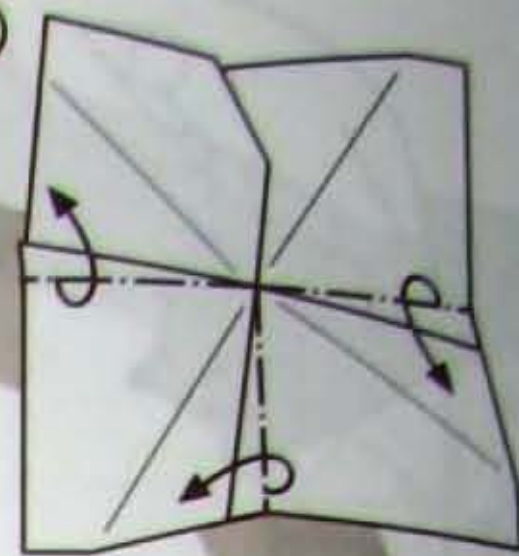

57



うえからみたく

61

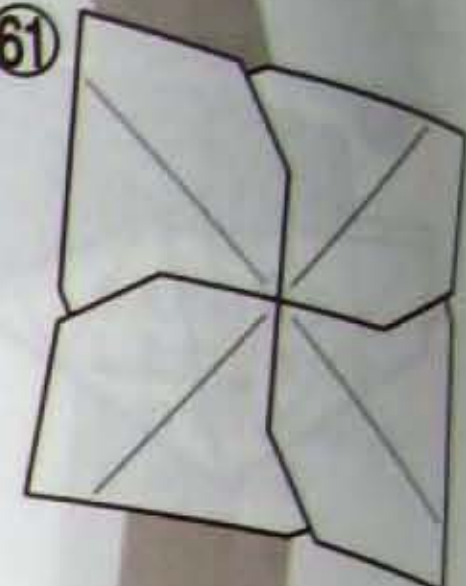

56

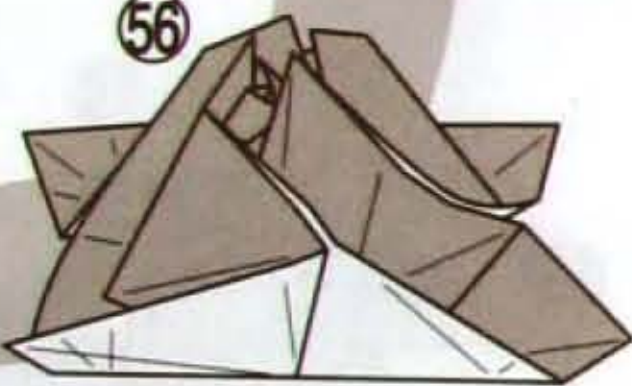

62



カドをめくるようにおる

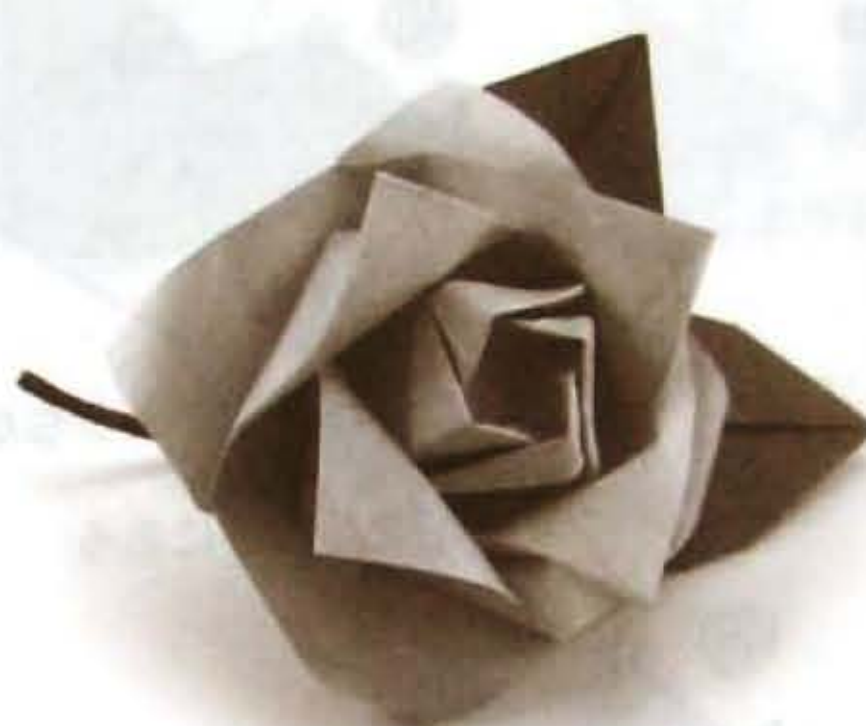

68

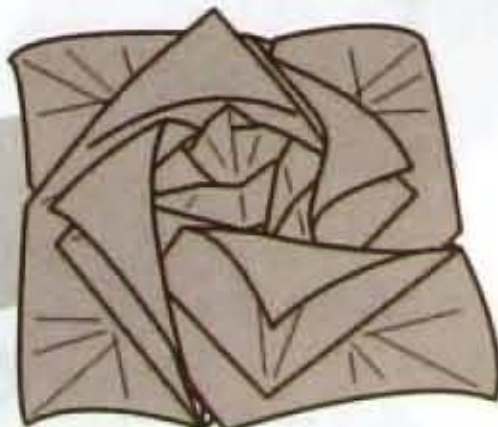

できあがり

67



はなびらをカールさせる

63



のこりのカドも
おなじようにおる

66



65

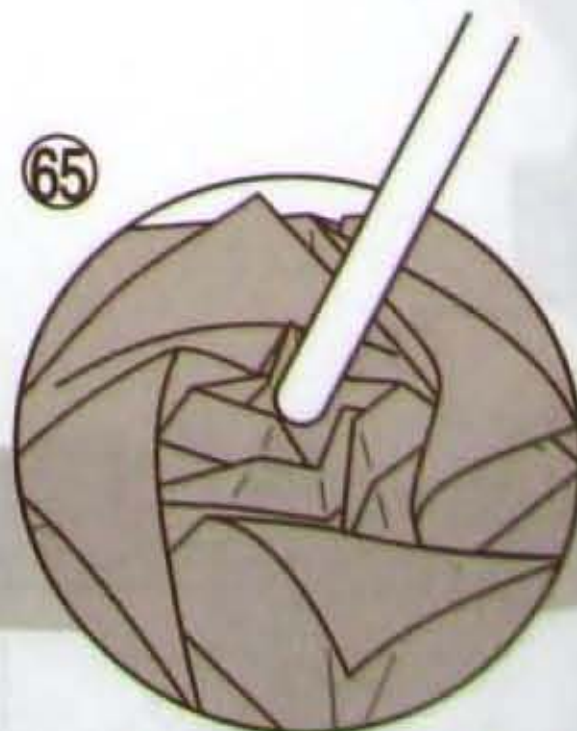

さきのほそいもので
ちゅうしんを
ひろげるようにする

64



Japão Burajirujin

www.japaoburajirujin.blogspot.com

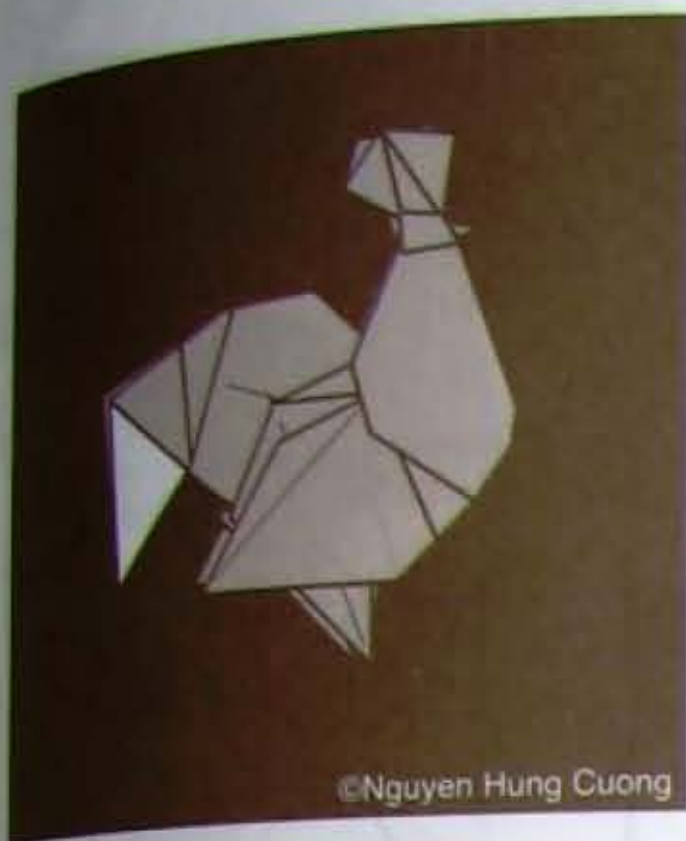

©Nguyen Hung Cuong



©Manuel Sirgo

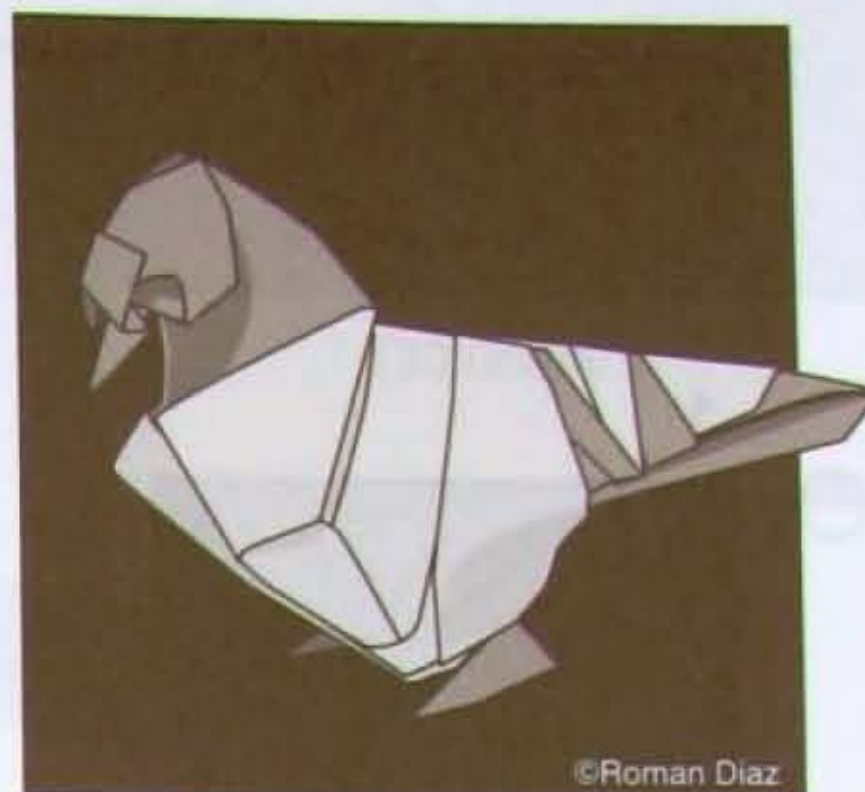

©Roman Diaz

第17回折紙探偵団コンベンション折り図集

17th Origami Tanteidan Convention Book

海外編 / Models by Foreign Folders



©Quentin Trollip



©Tran Trung Hieu

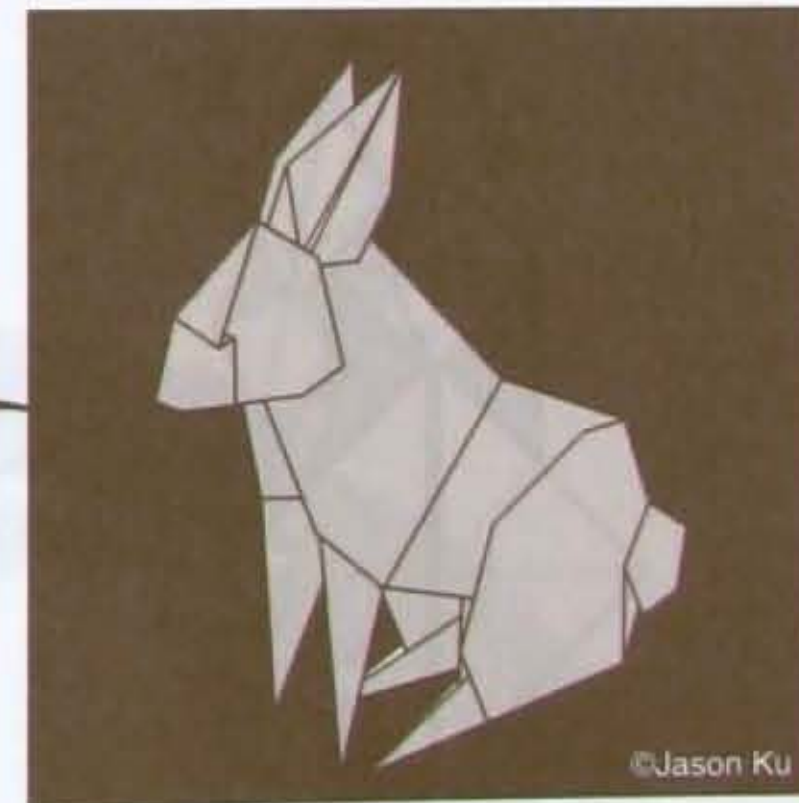

©Jason Ku

Estrelina ©2010

By Isa Klein (MG, Brasil)
Diagram by Márcio Noguchi (NY, USA)

12 or 30 units
7,5 cm, double face recommended.

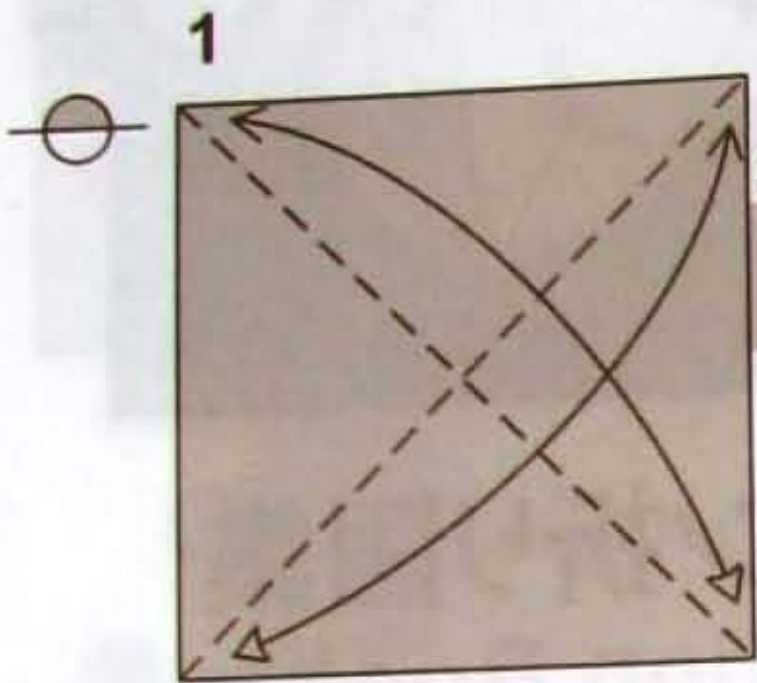
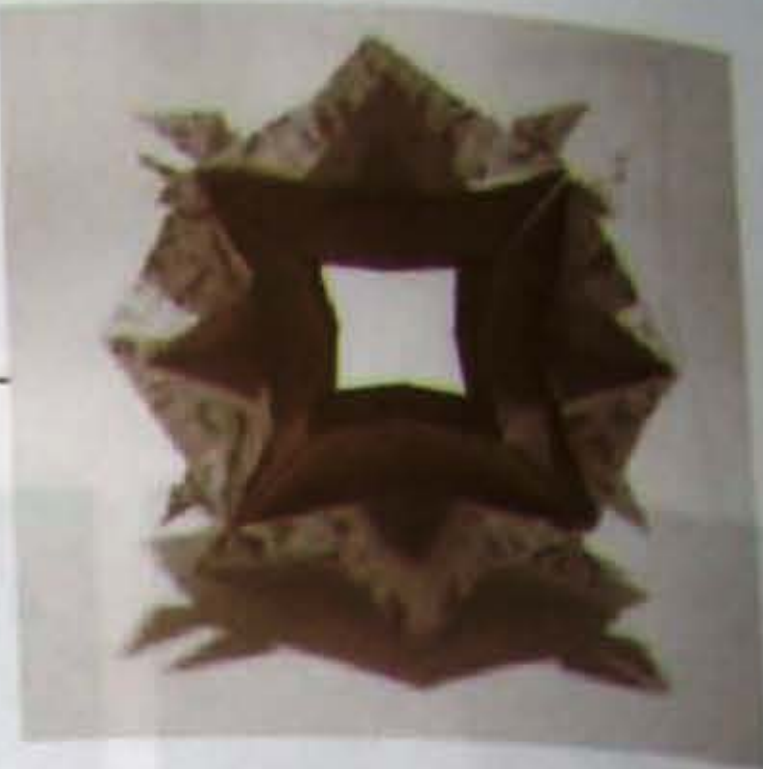

1
Fold and unfold two diagonals. Turn over.

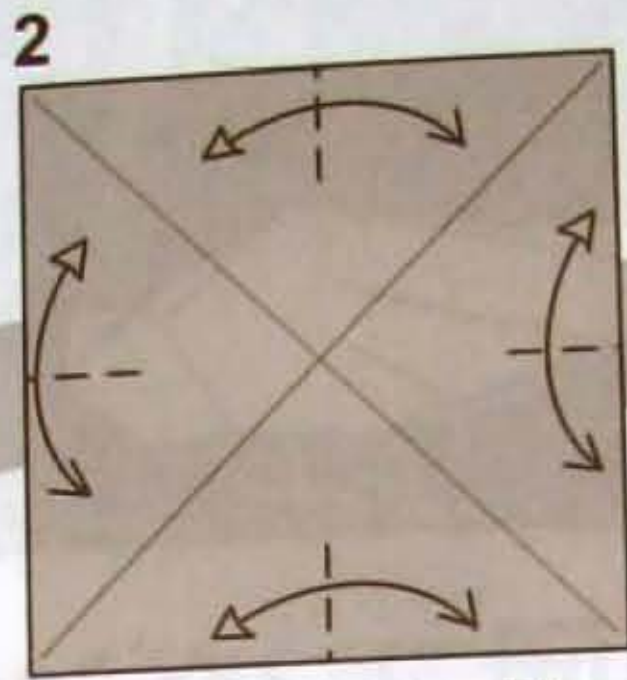

2
Pinch the center of the edge.

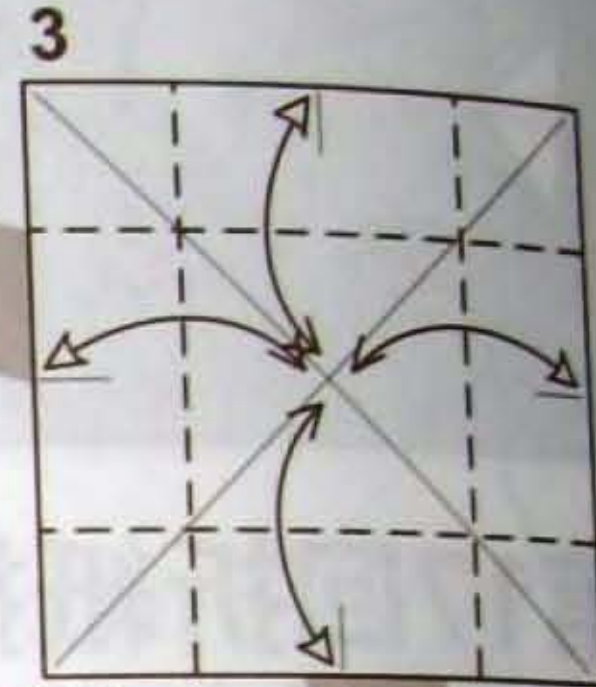

3
Fold edge to the center and unfold. Rotate 45° and turn over.

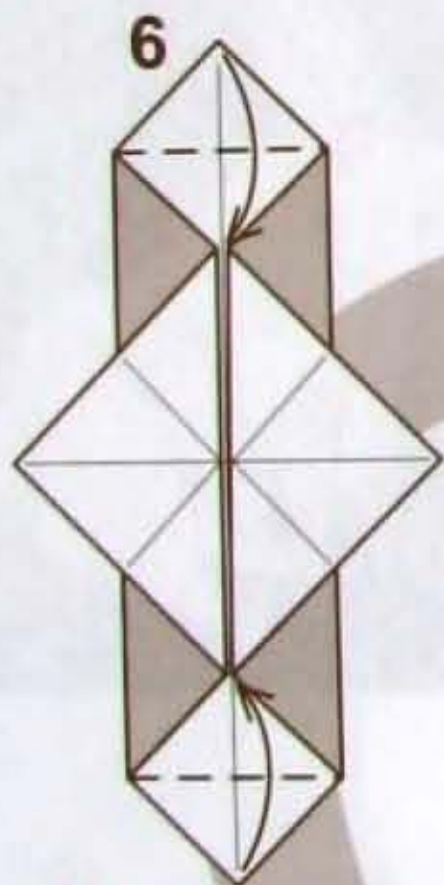

6
Fold the corner.

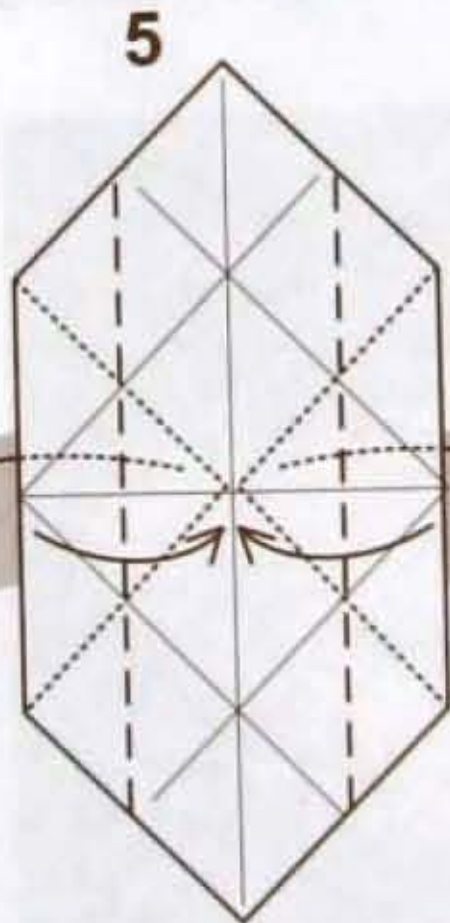

5
Fold the folded edge to the center allowing the flaps to flip over.

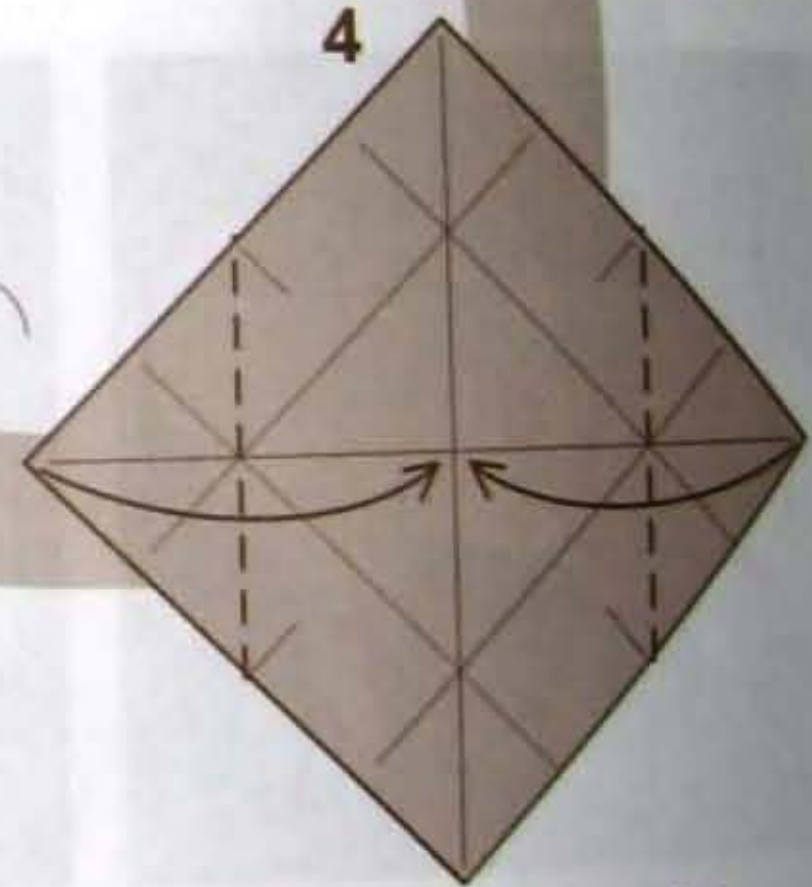

4
Fold corner to the center. Turn over.

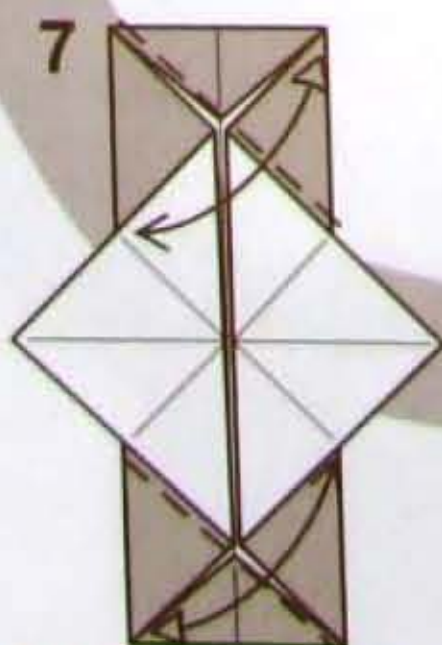

7
Fold the corner along the edge. Unfold.

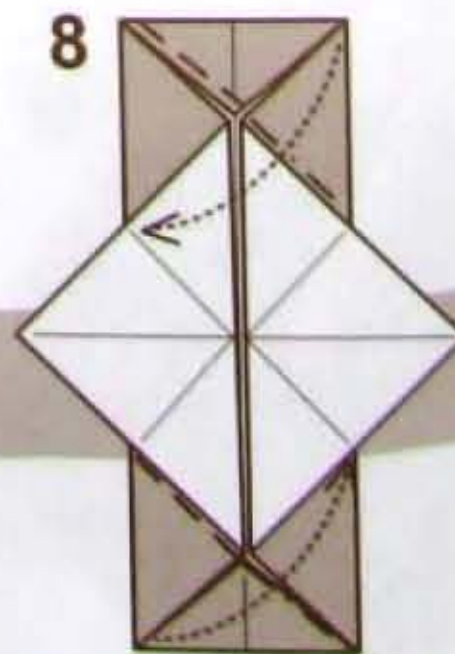

8
Inside reverse fold. Tuck the flap under the layer of the other side.

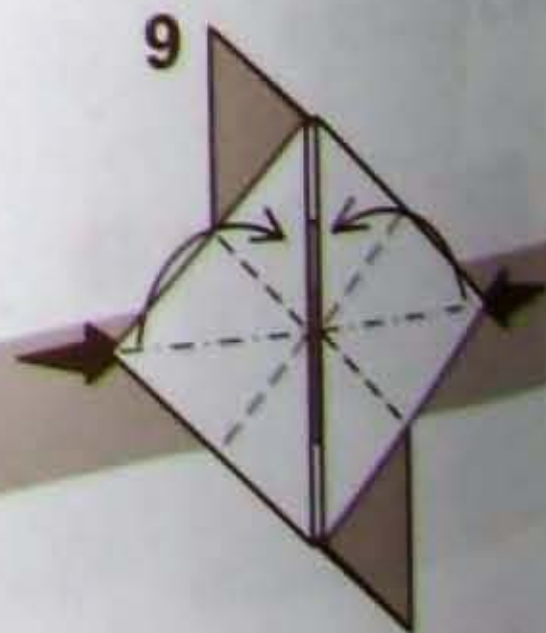

9
Using the existing crease, collapse what looks like a preliminary fold.

14

10

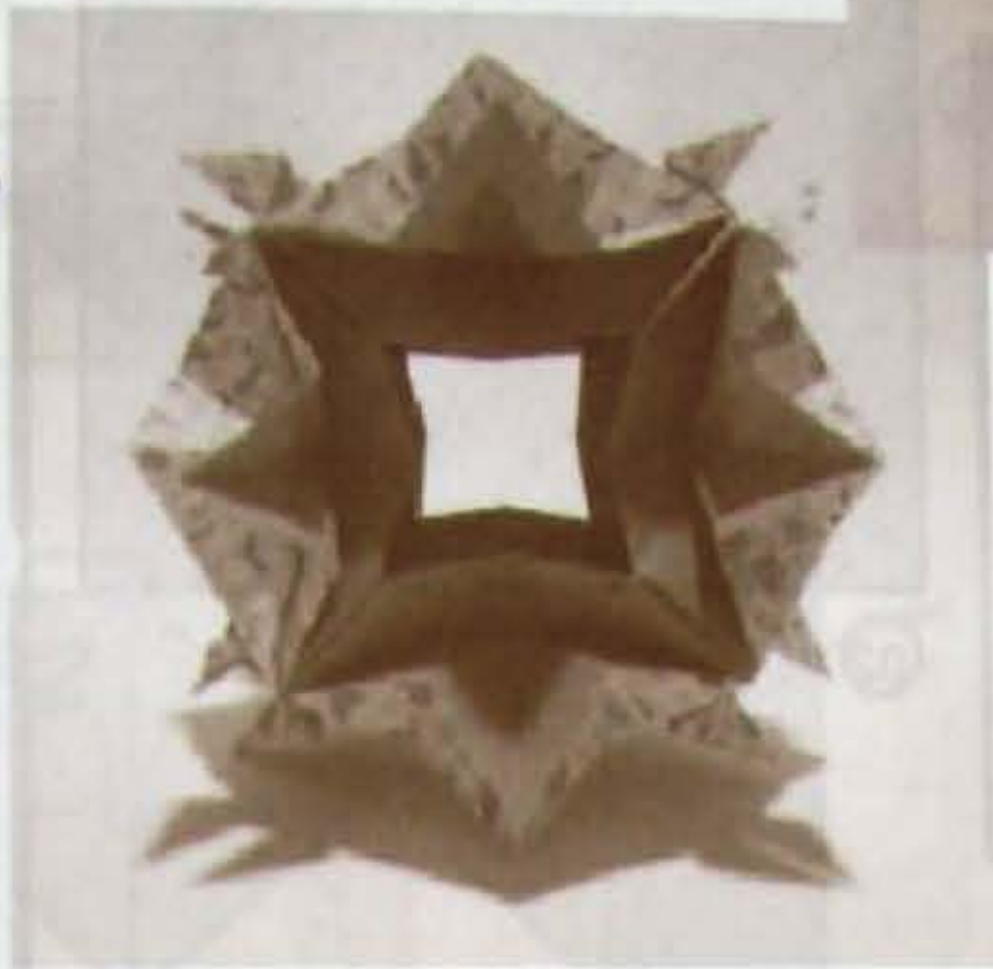
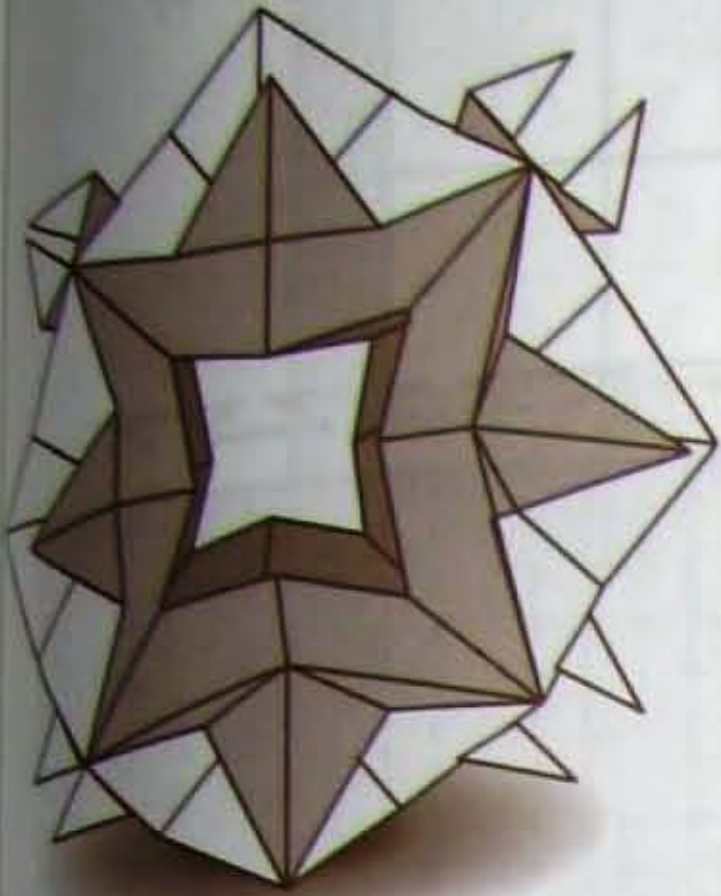

(12 units)



(30 units)

Assembly

The assembly uses the same principles of the Sonobe modular. It can be assembled with 12, 24, 30 modules and so on.

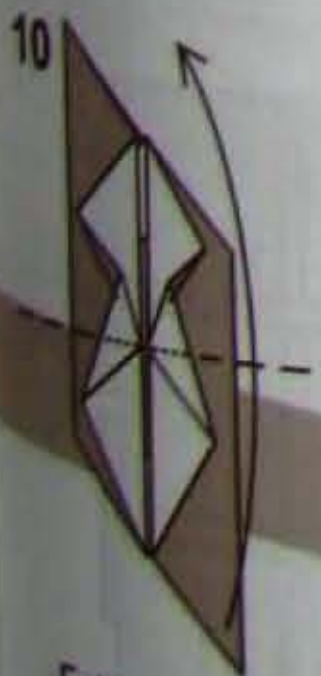
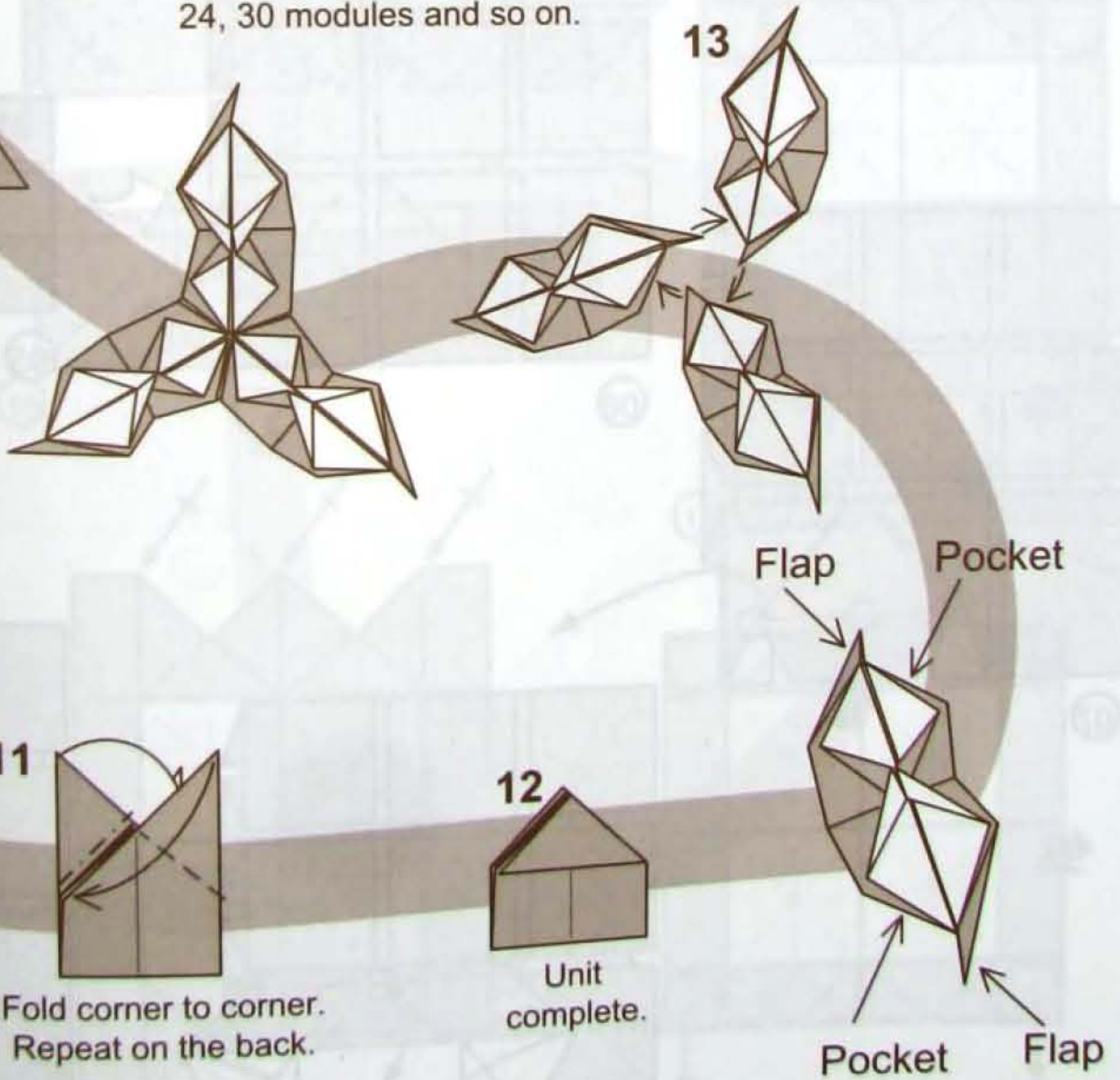
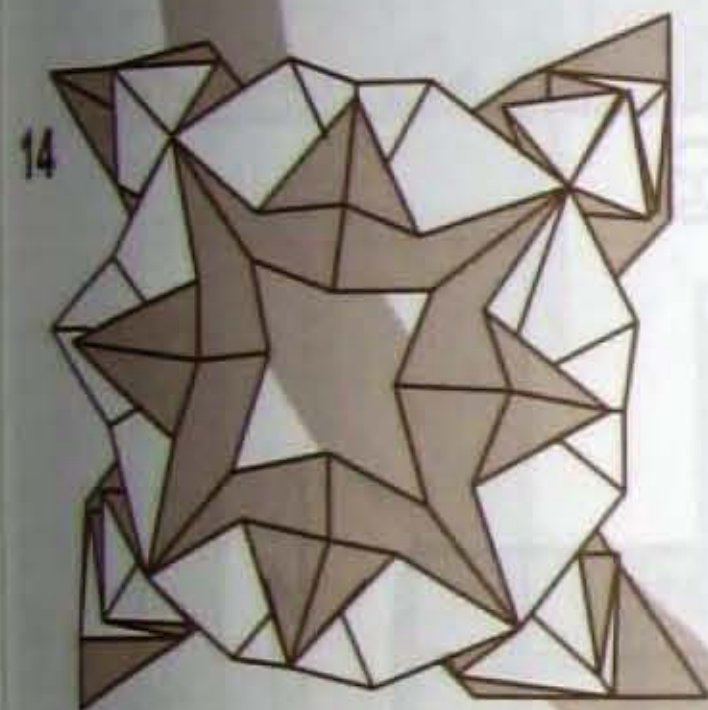

Fold in half, so that the model will lie flat again.

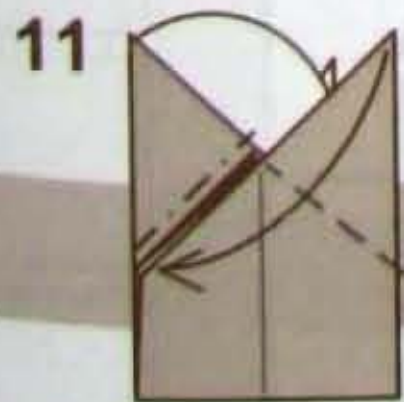

Fold corner to corner. Repeat on the back.



Unit complete.

Flap Pocket

Pocket Flap

existing
apse what
preliminary
d.

Tessellation

Design & Diagrams by Anna Kastlunger (2010)

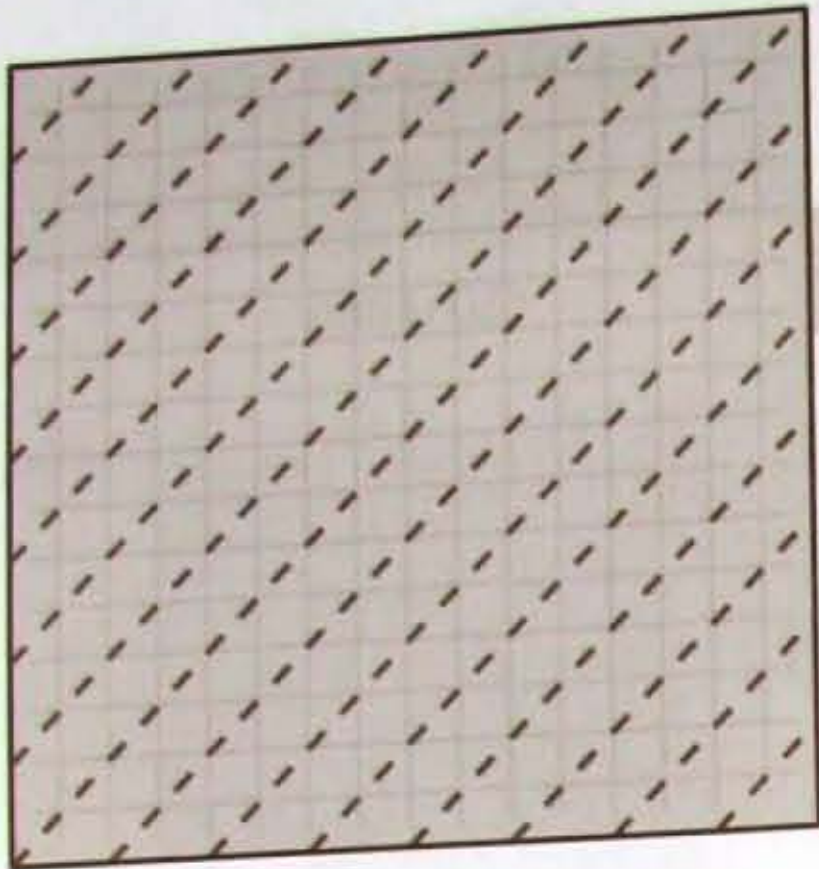

01

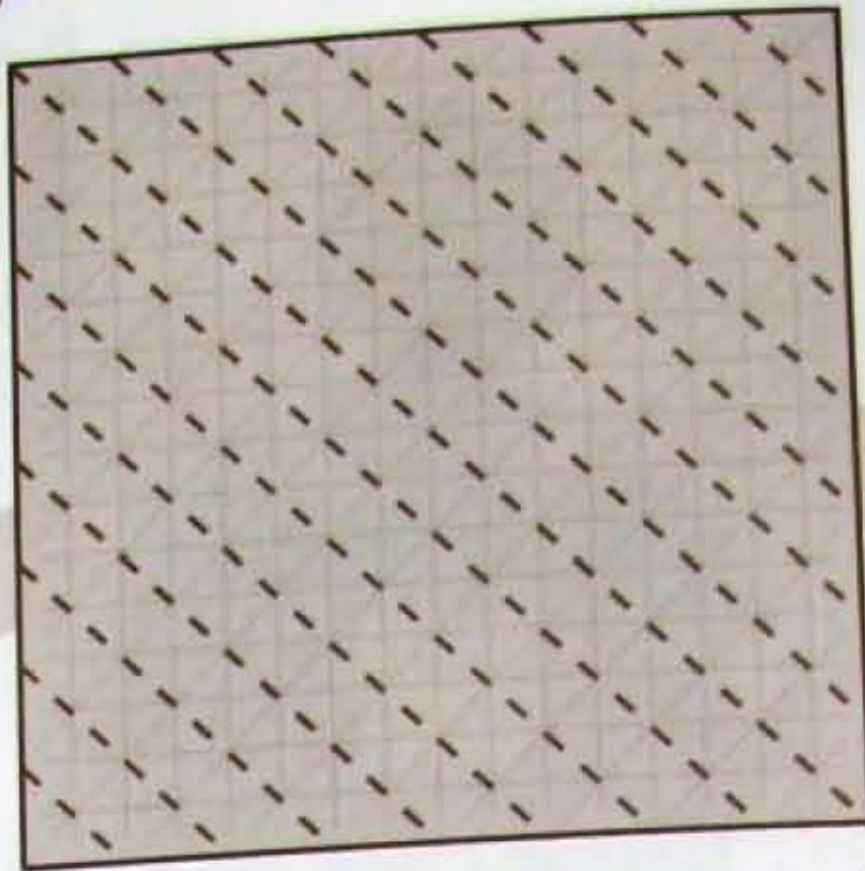

02

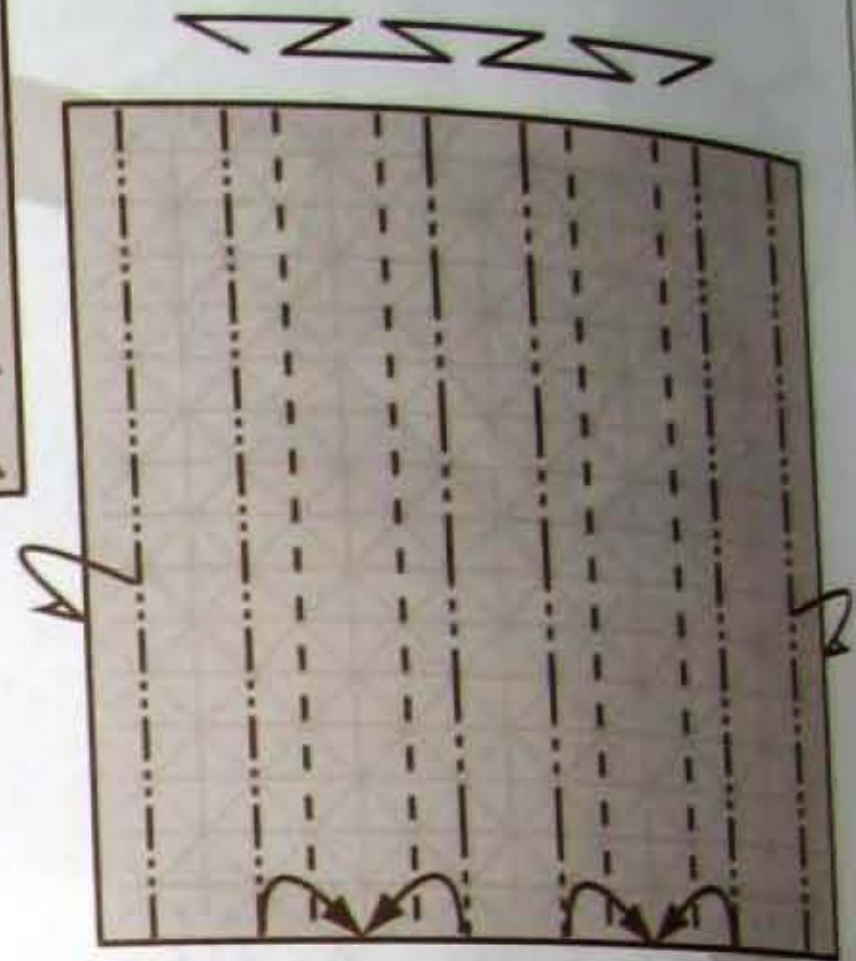

03

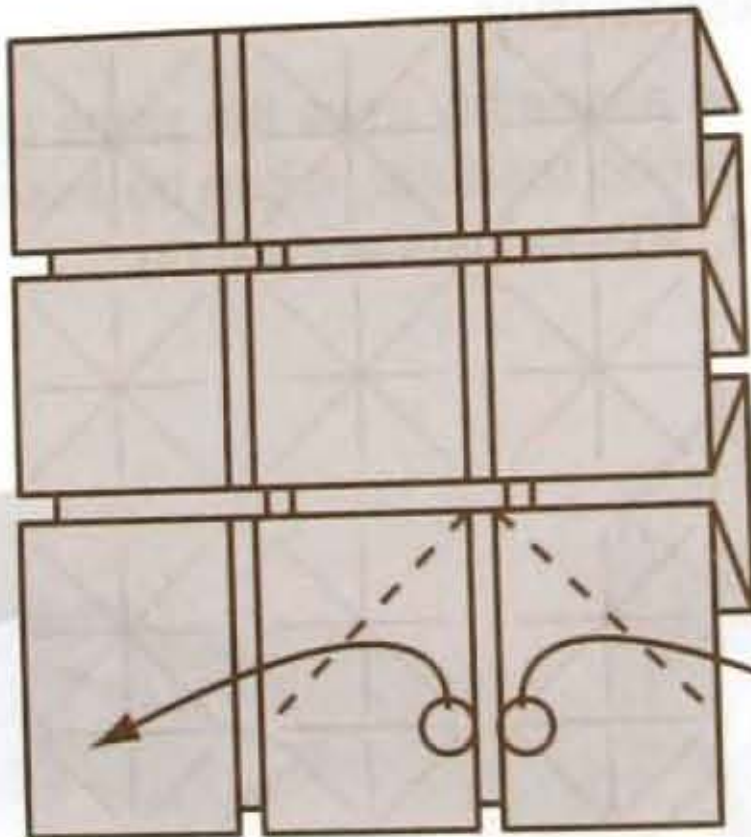

04

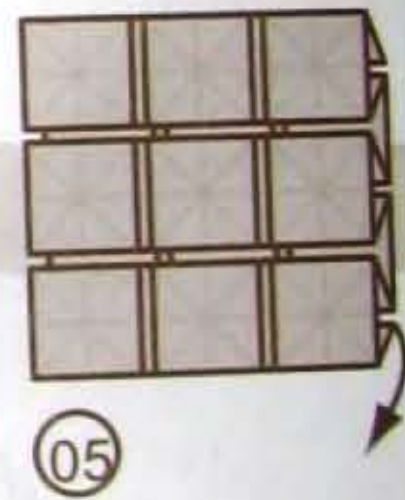

05

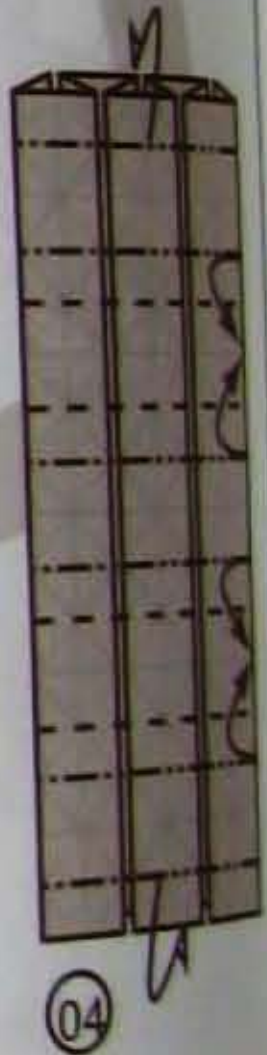

06

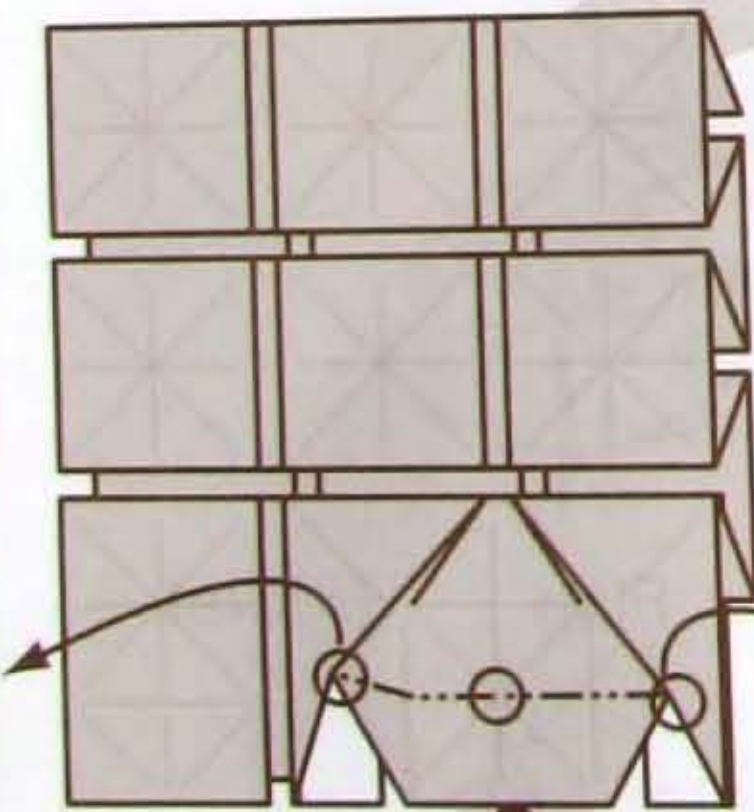

07

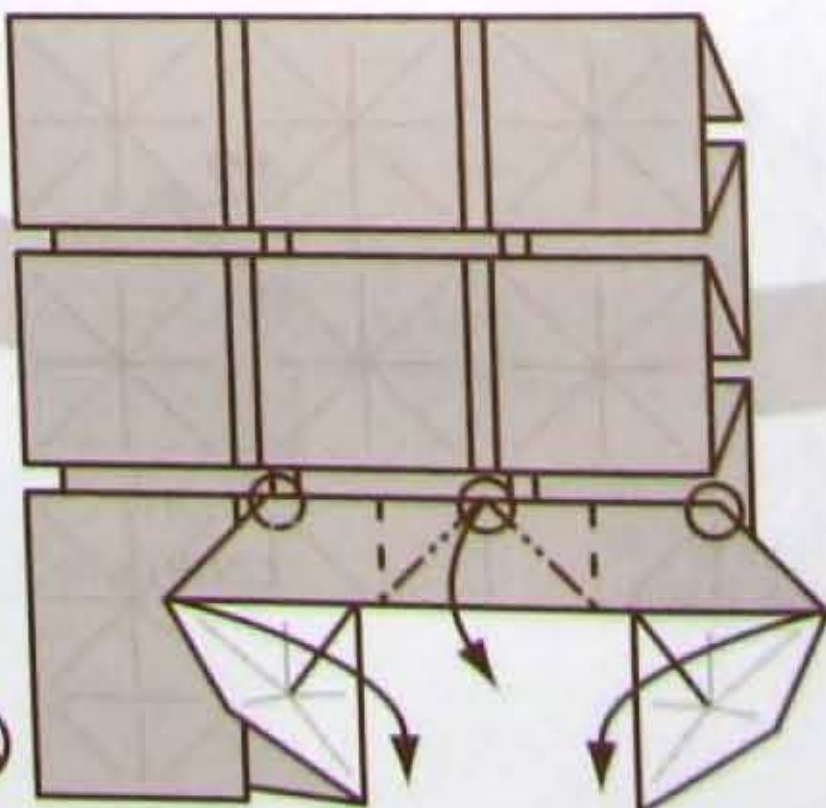

08

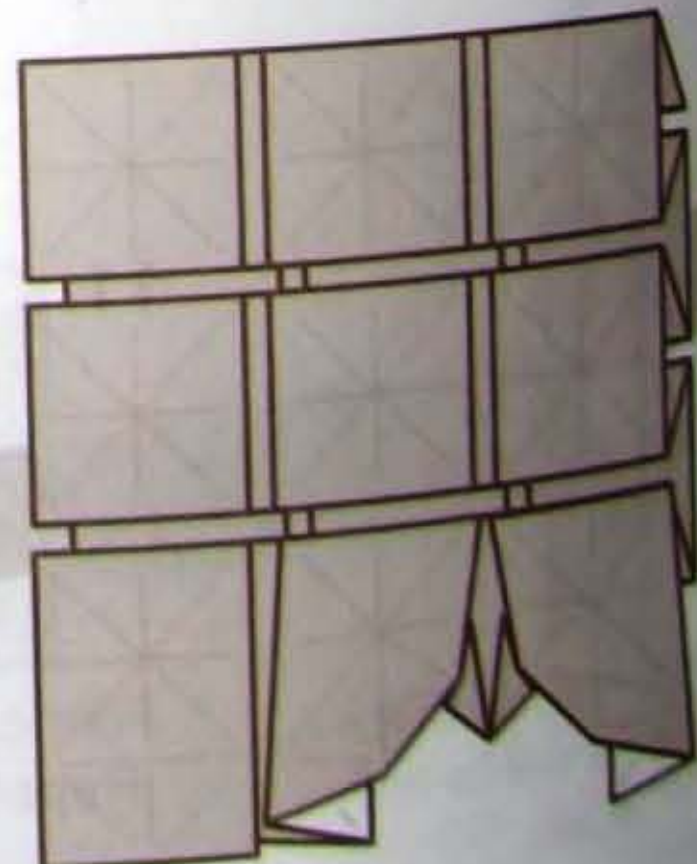

09



10



11

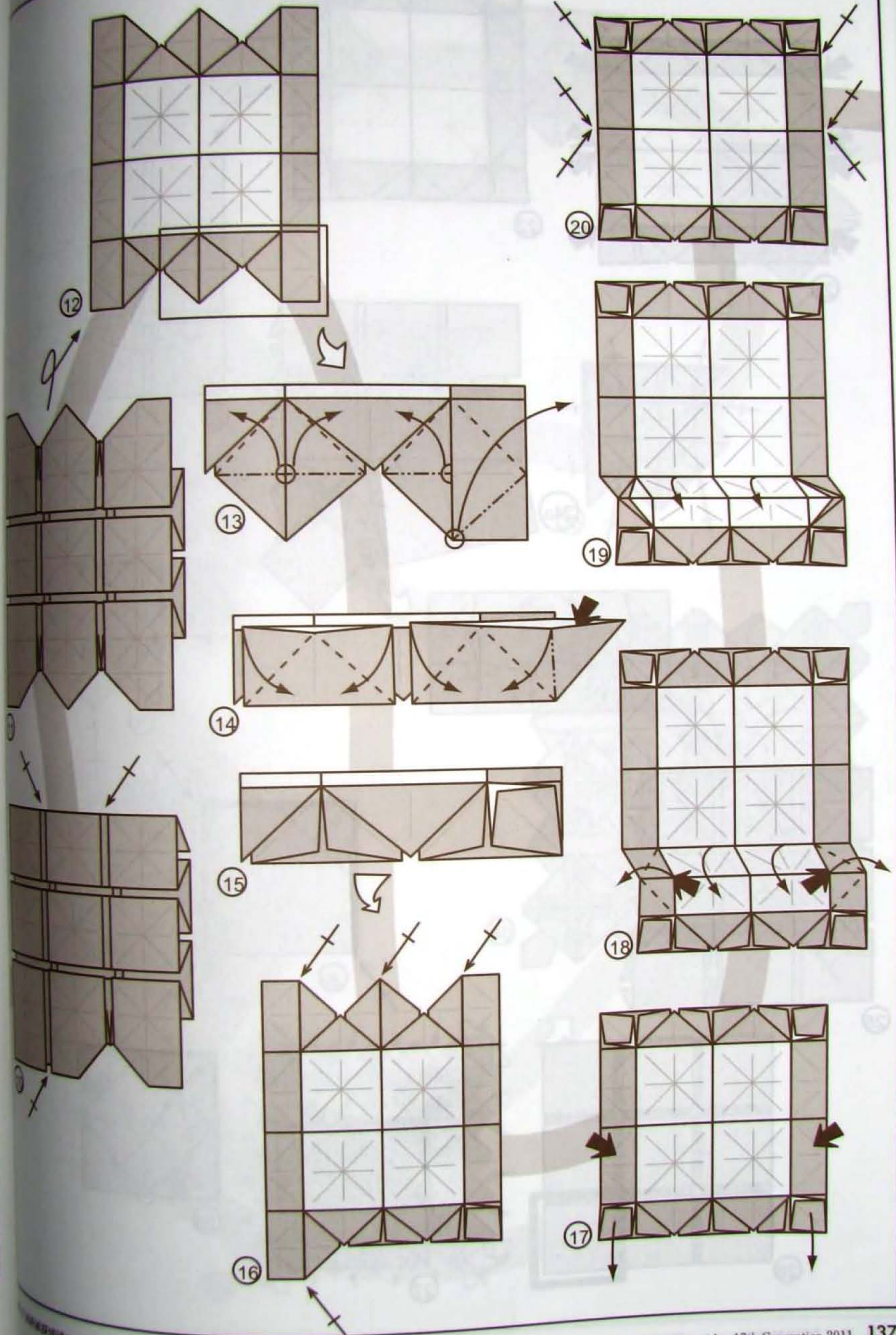

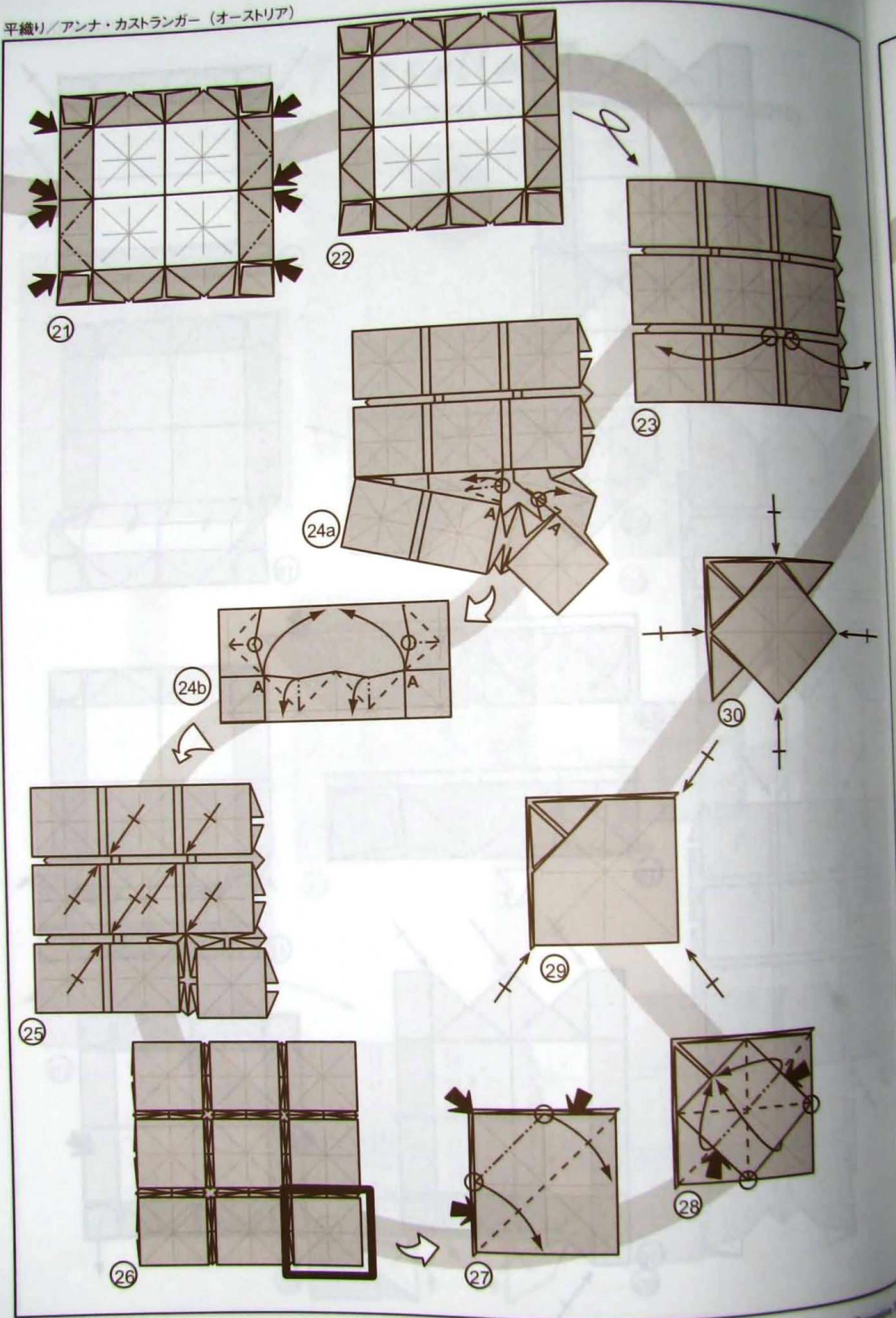

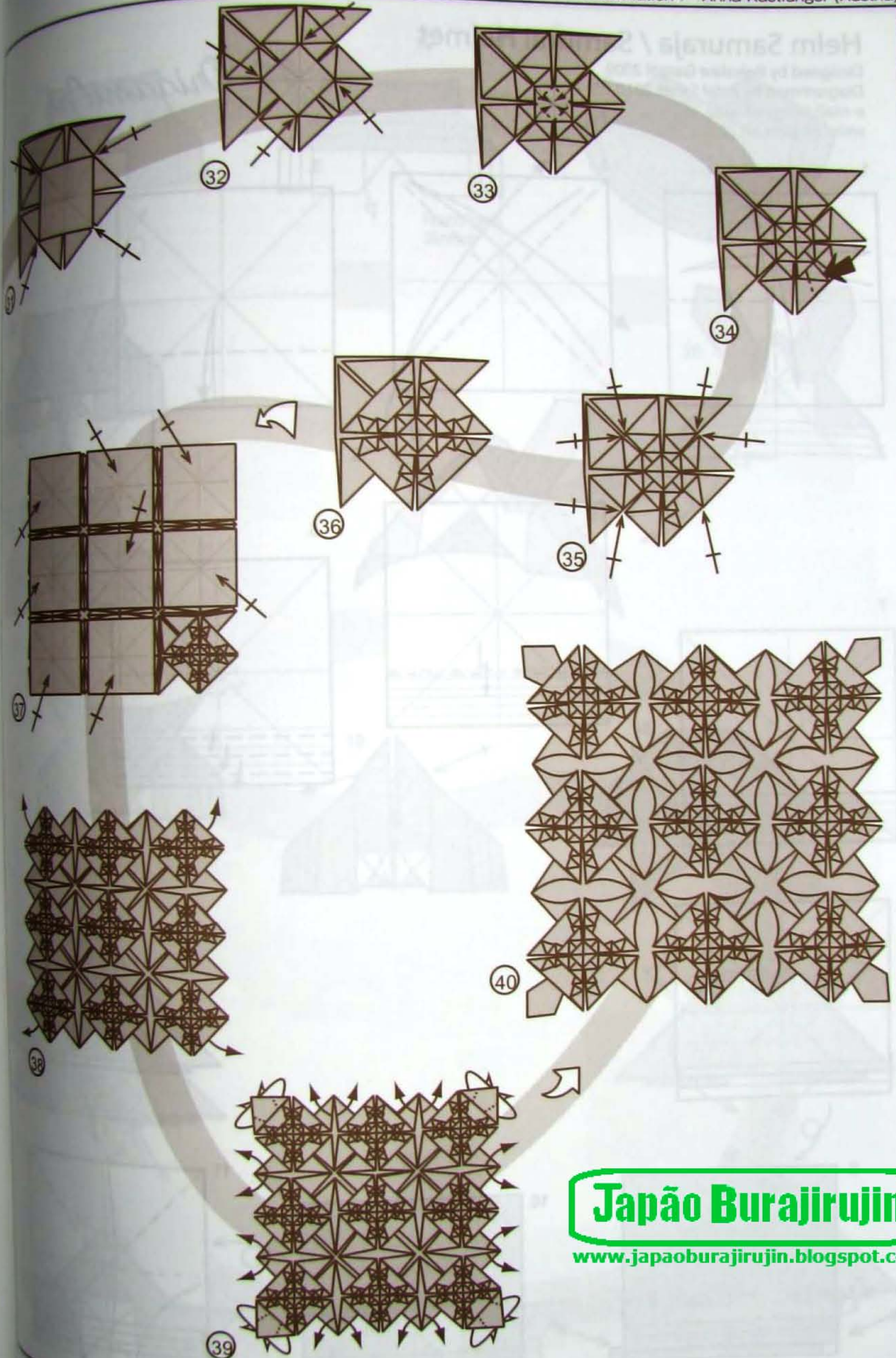

Japão Burajirujin

www.japaoburajirujin.blogspot.com

Helmet Samurai / Samurai Helmet

Designed by Boleslaw Gargol 2009
Diagrammed by Rafal Sabat 2010
e-mail: bolgar@wp.pl
www.origami.art.pl

OrigamiArt

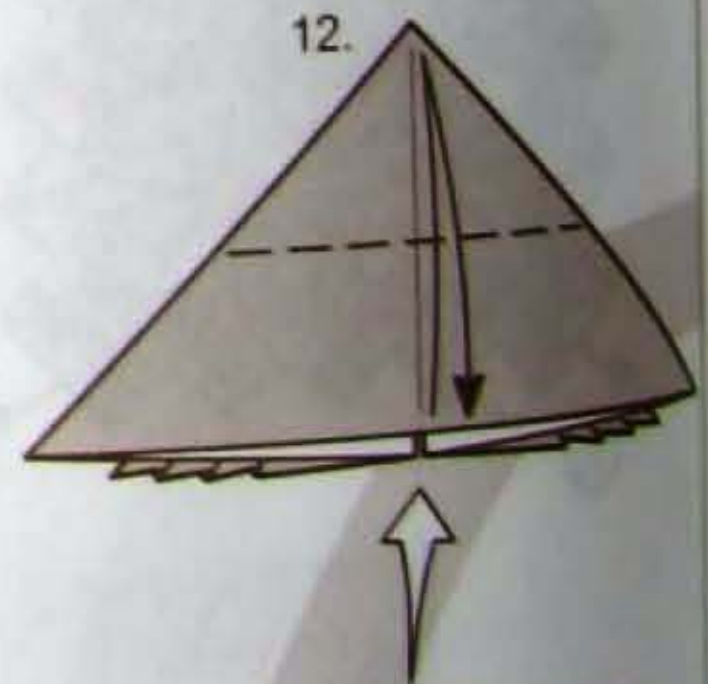
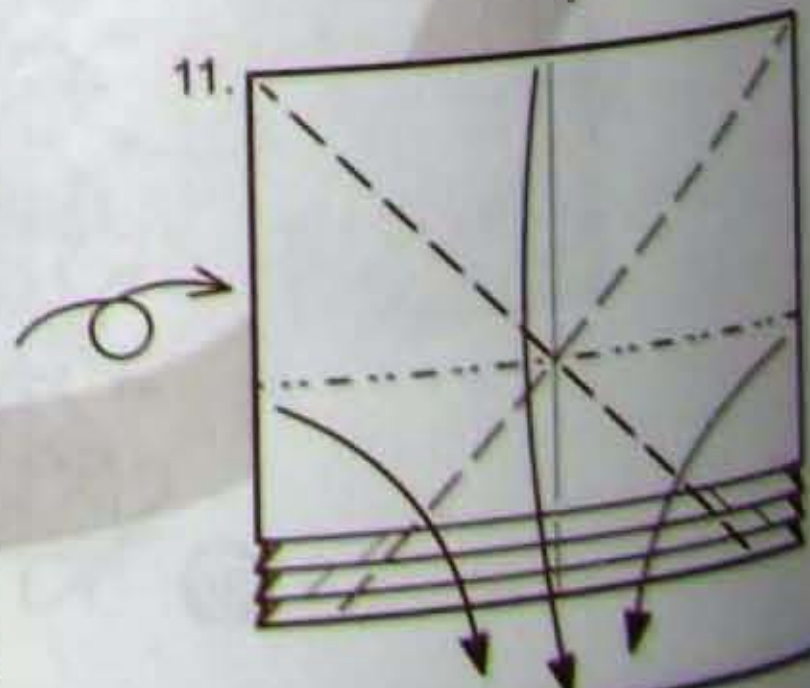
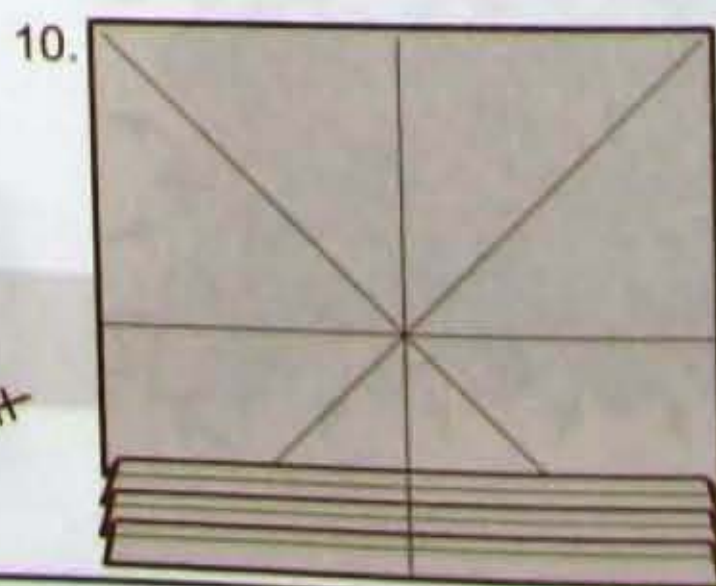
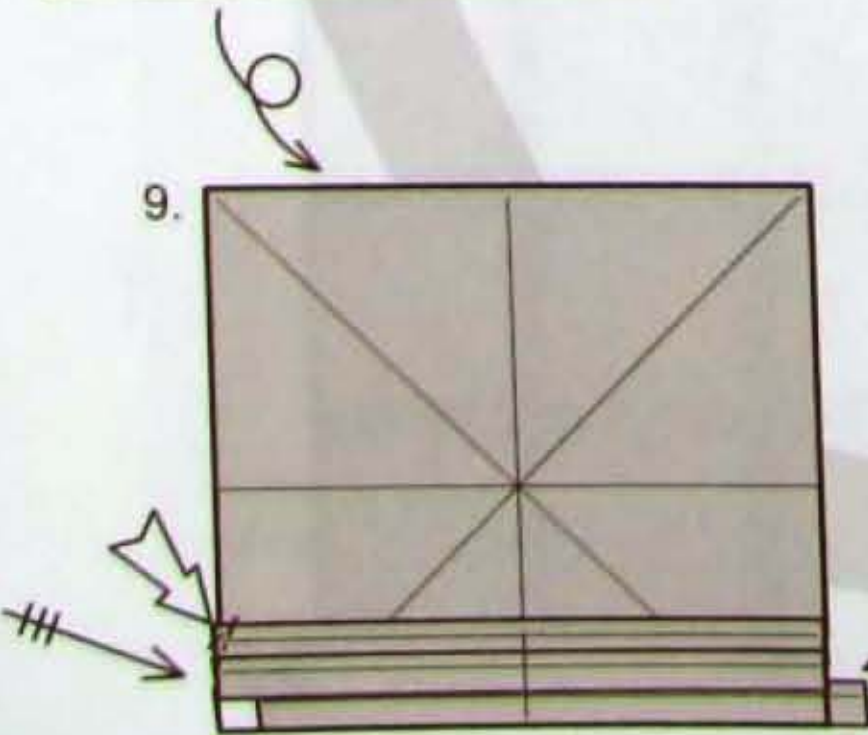
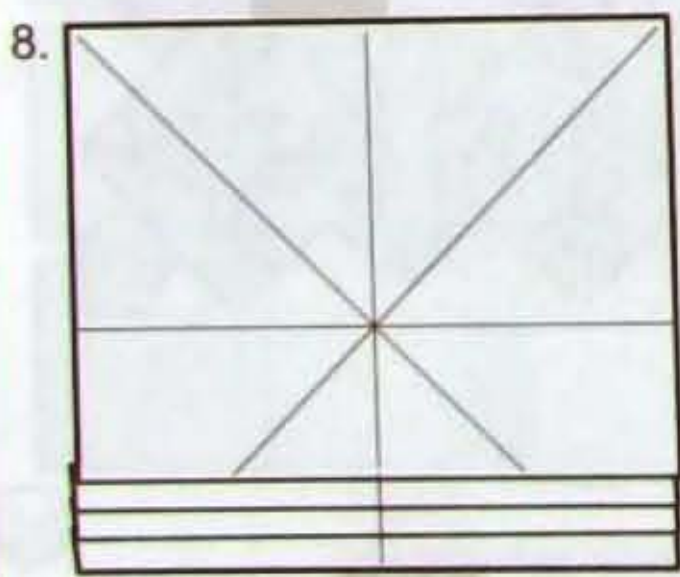
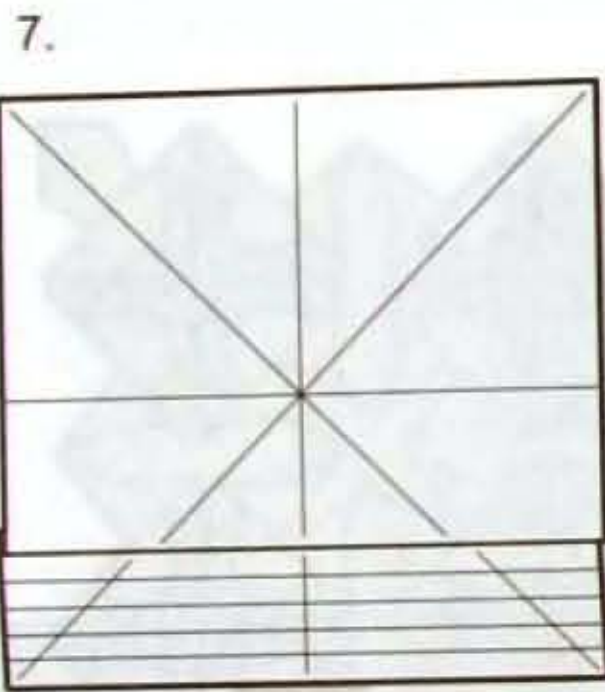
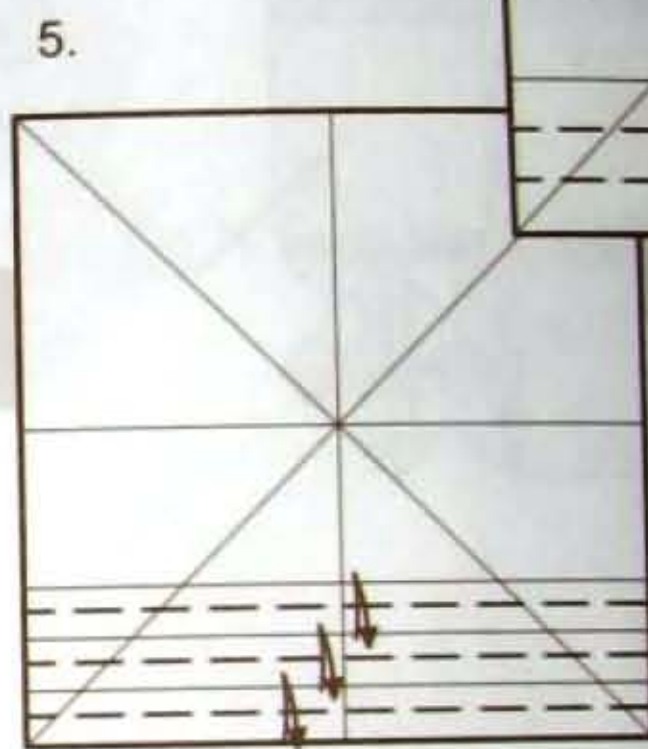
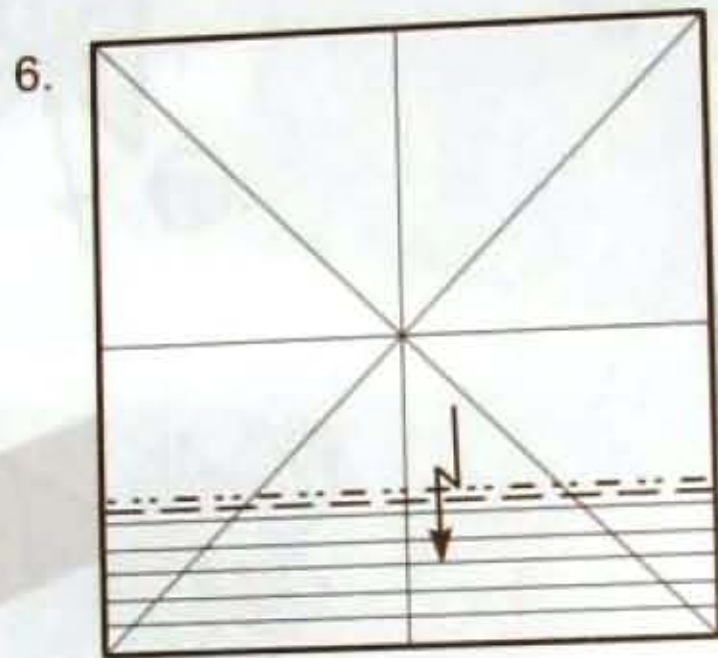
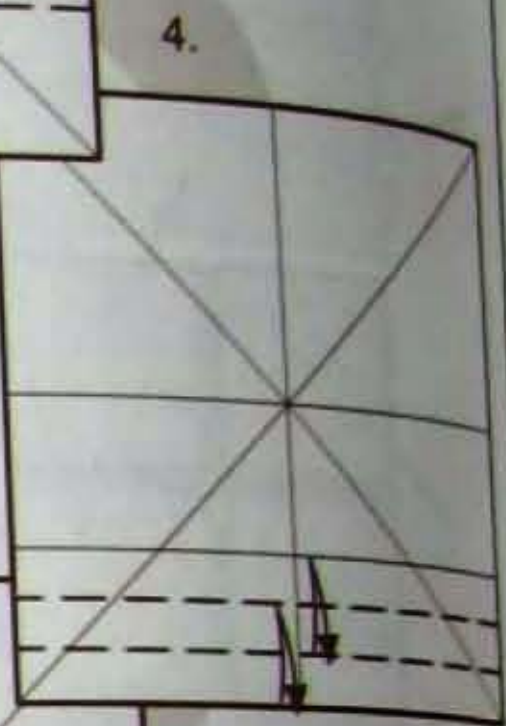
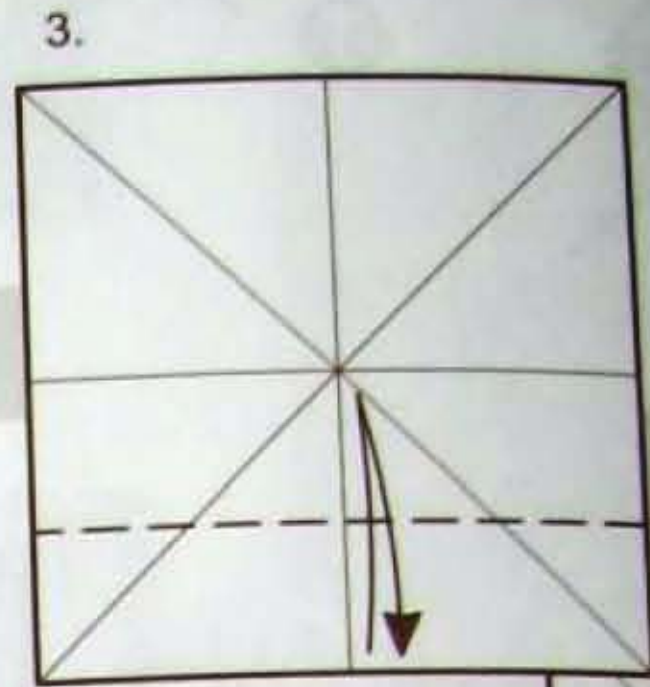
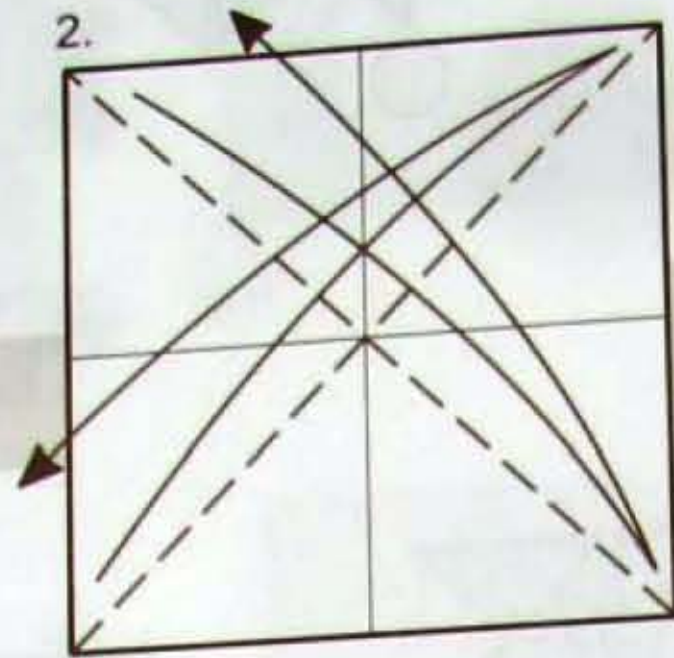
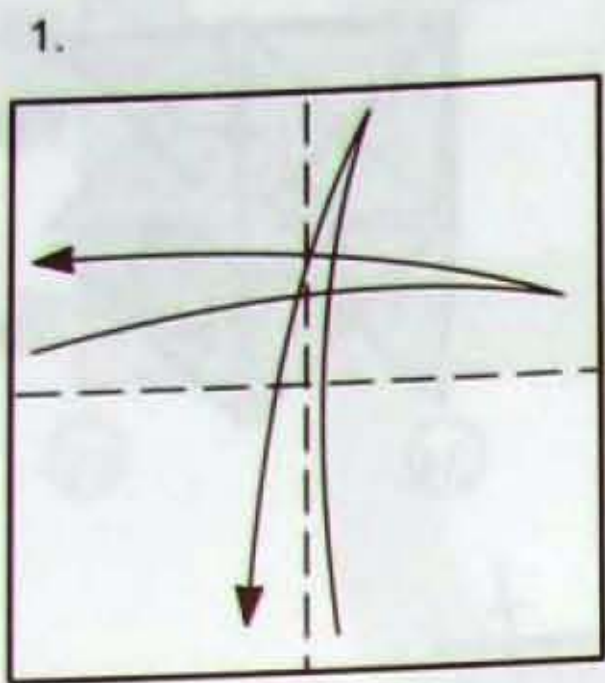

23.

22.

21.

20.

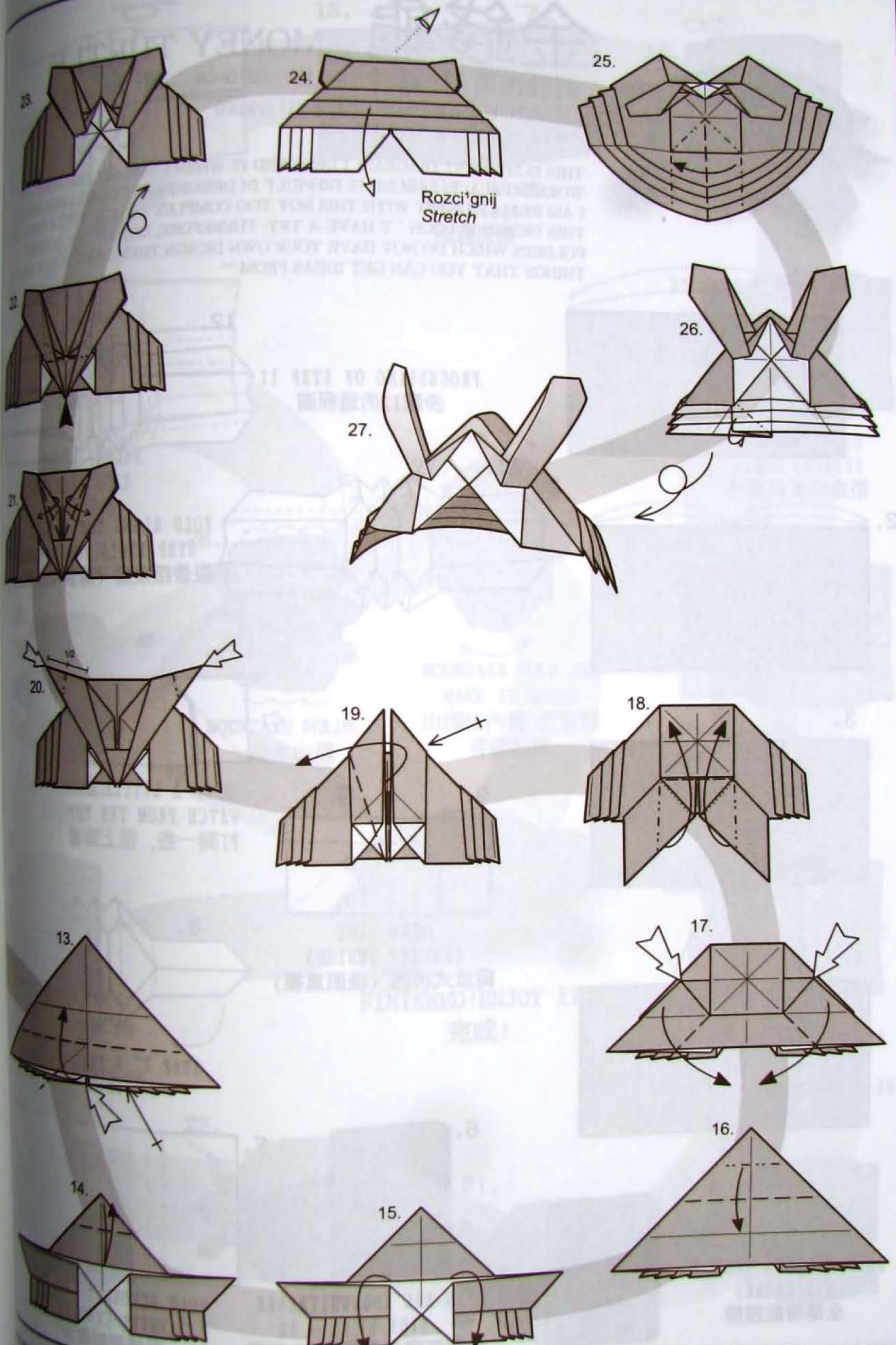

金錢龜

MONEY TURTLE

創作&圖解: 羅瑜

作: 2010-08 圖: 2011-05

CREATOR & DIAGRAM: LO YU (ylo33)
PAPER - 1:2 OR LONGER



THIS IS MY FIRST DIAGRAM. I DESIGNED IT WHEN I WAS ON THE WAY TO WORKING PLACE. I FOUND IT DIFFIULT IN DESIGNING DETAILED FIGURES,SO I AM REALLY HAPPY WITH THIS NOT TOO COMPLEX DESIGN. I WILL NOT HAVE THIS DESIGN IF I DON ' T HAVE A TRY; THEREFORE, LET ' S TRY, EVERY FOLDERS WHICH DO NOT HAVE YOUR OWN DESIGN,THERE ARE MANY MANY THINGS THAT YOU CAN GET IDEAS FROM^^

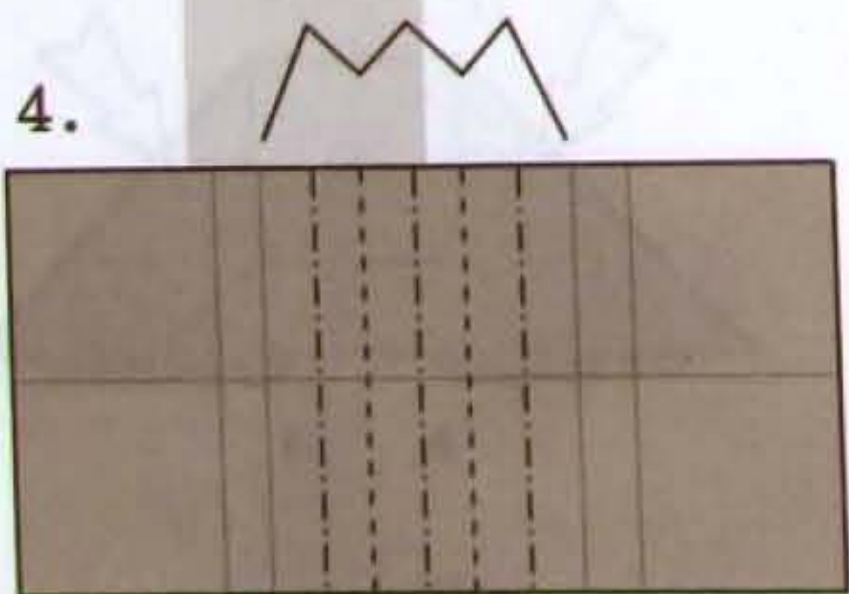
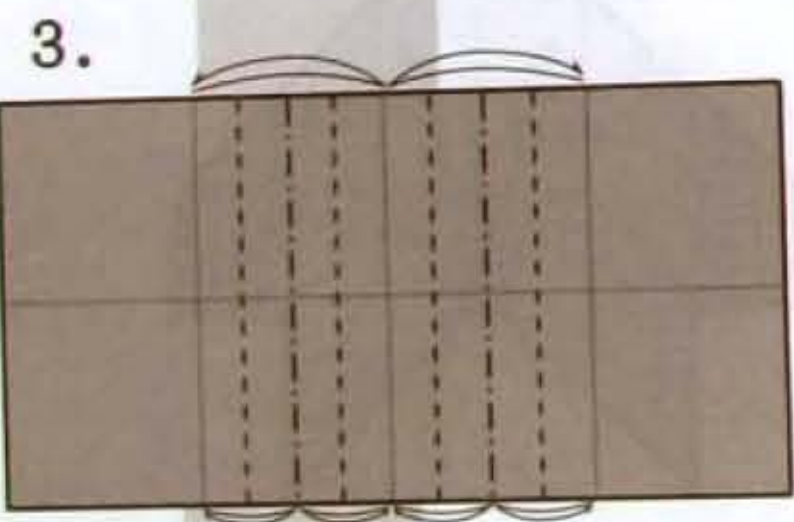
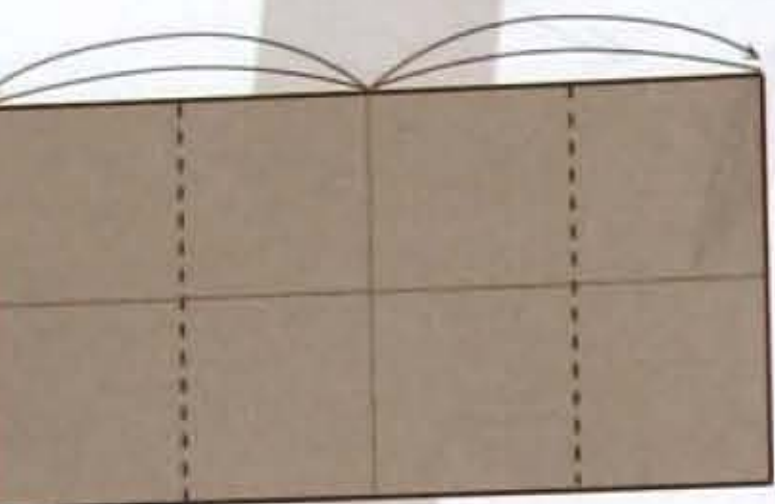
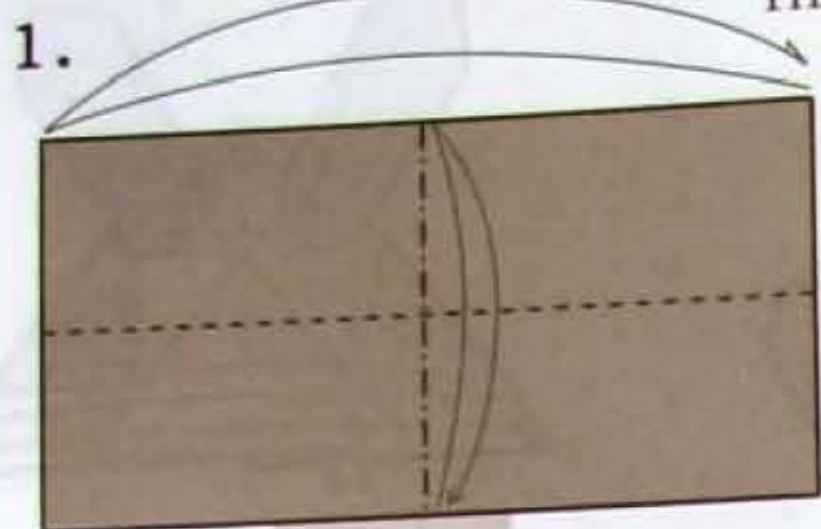

FOLD CREASES THROUGH ALL LAYERS
全部層數預摺

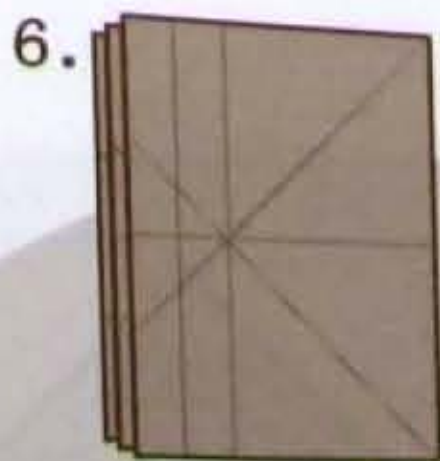
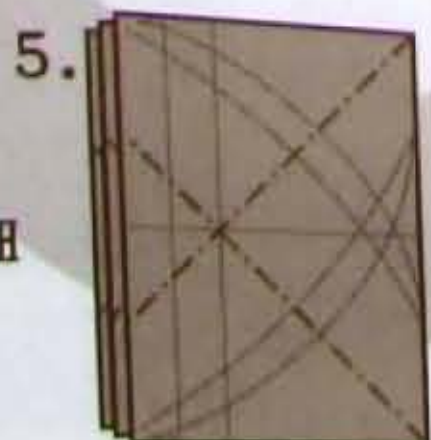

OPEN ALL AND WHITE SIDE UP
全部打開白色面向上

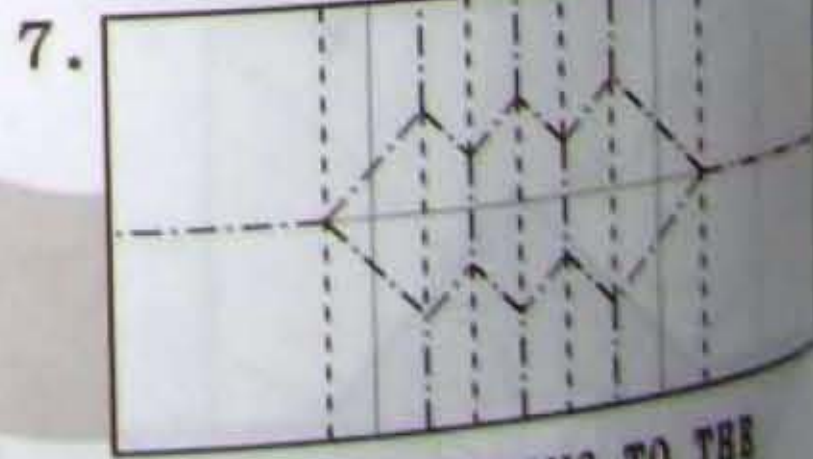

FOLD ACCORDING TO THE EXIST CREASES
根據摺線聚合

PROCESSING OF STEP 11
步驟11的過程圖

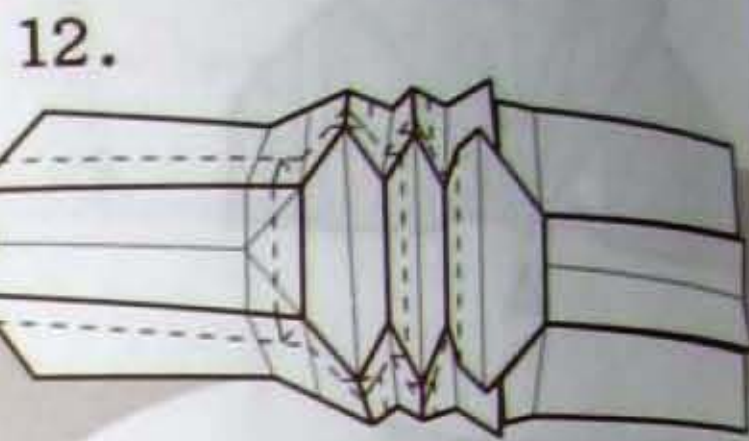
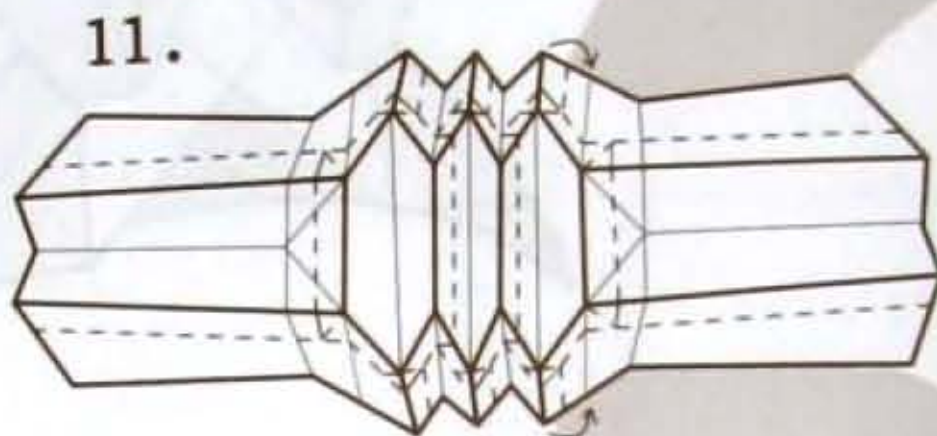

FOLD ALONG THE CREASE (WATCH STEP 12-13 FOR REFERENCE)
跟著摺痕摺 (請參考步驟12-13)

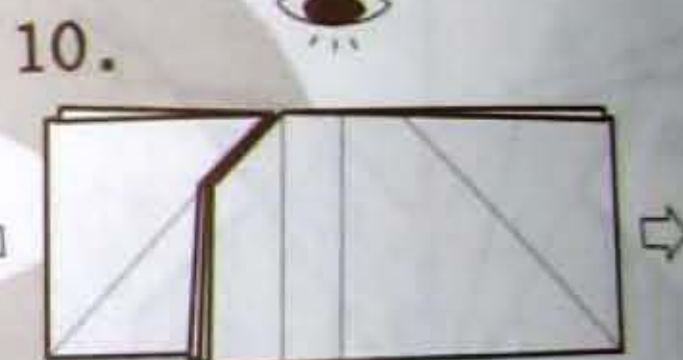

OPEN A LITTLE AND WATCH FROM THE TOP
打開一些, 從上面看

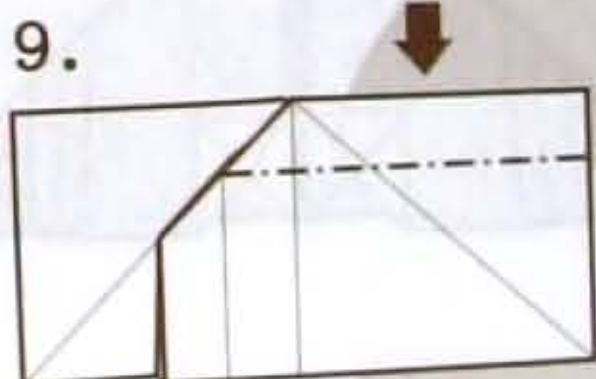

OPEN SINK (REPEAT BEHIND)
開放式沉摺 (後面重複)

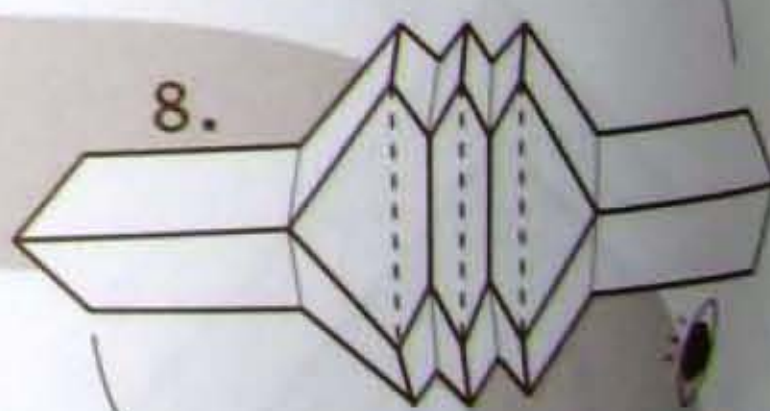

STEP 7 ' S PROCBSSING
合上

14.

13.

25.

24.

23.

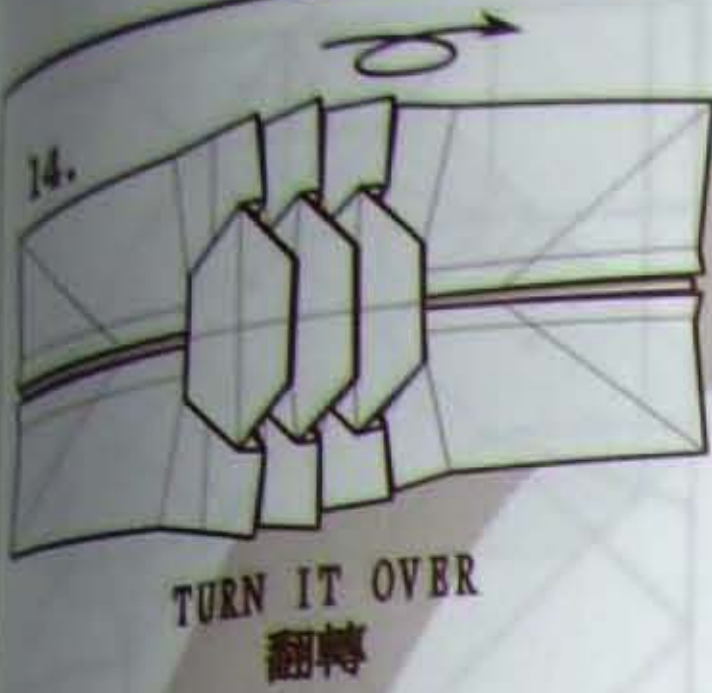

14. TURN IT OVER
翻轉

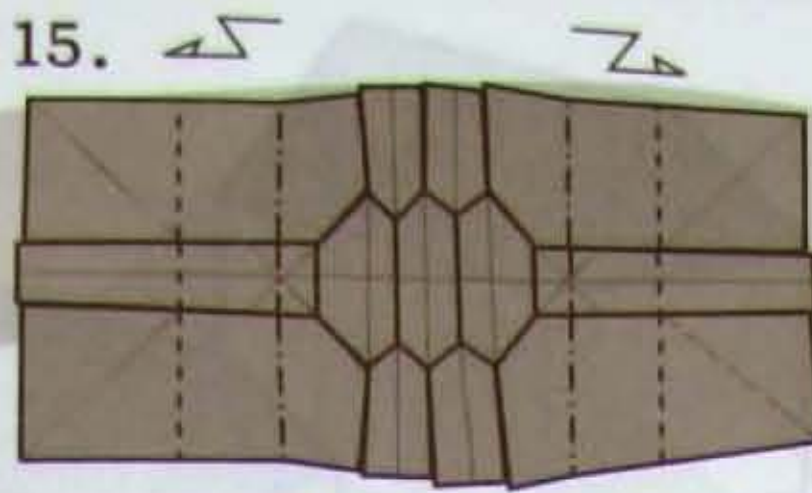

15. PLEAT FOLD ON
TWO SIDES
兩邊段摺

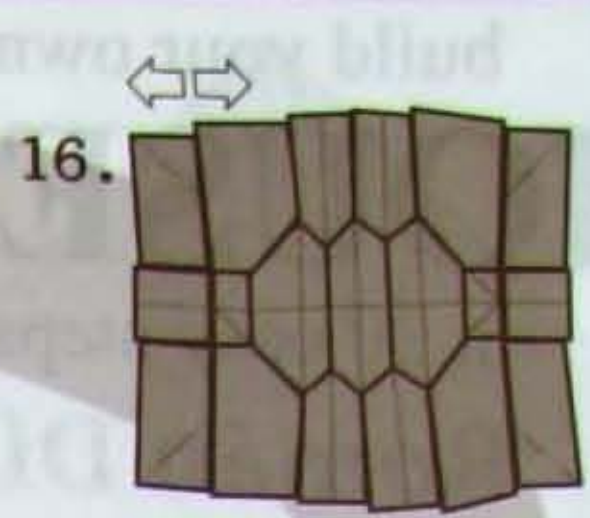

16. OPEN
打開

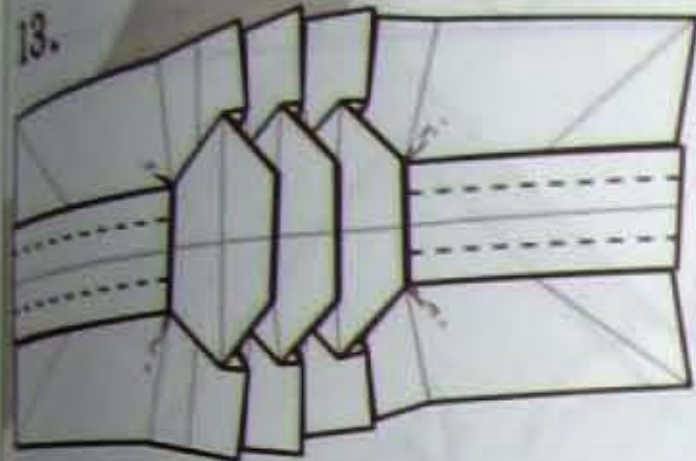

17. 4 TIMES INSIDE
REVERSE FOLD
4次中分摺

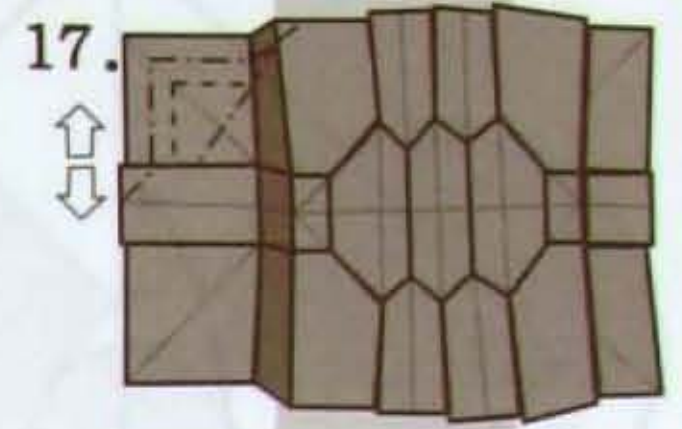

18. OPEN AND FOLD
ALONG CREASES
打開跟著摺痕摺



19. FOLD THE TAIL
摺尾巴

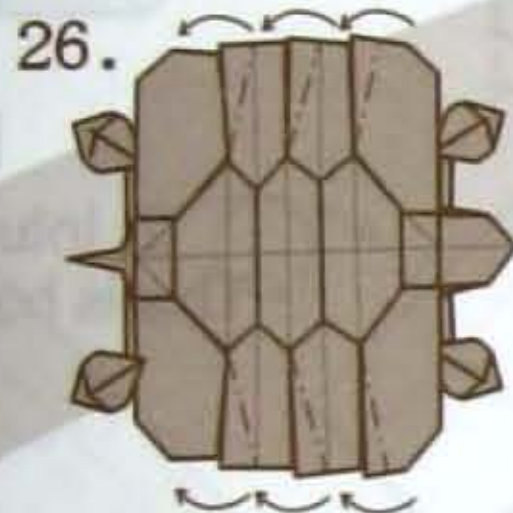

20. MOUNTAIN FOLDS
一連串山摺



21. MOUNTAIN FOLD AND
MAKE IT ROUND
山摺往內塞,把整體
弄圓鼓起

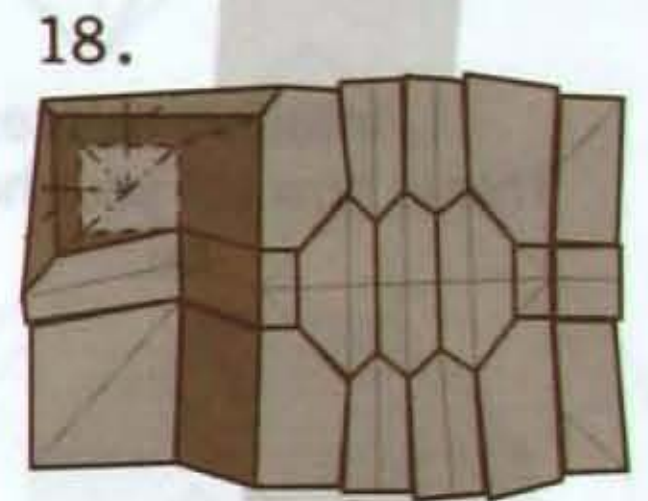

22. FOLD ALONG THE
CREASES
跟著摺痕聚合

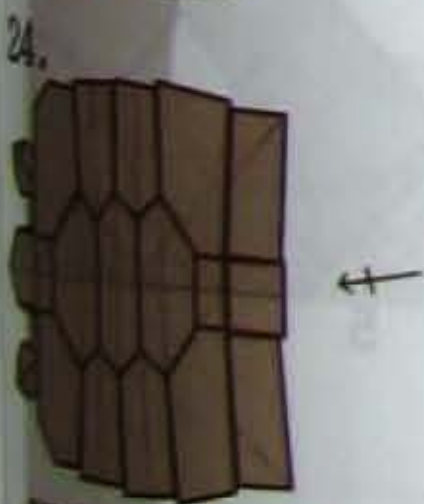

23. REPEAT 17 - 25 ON
THE RIGHT.
在右邊重複步驟17-25

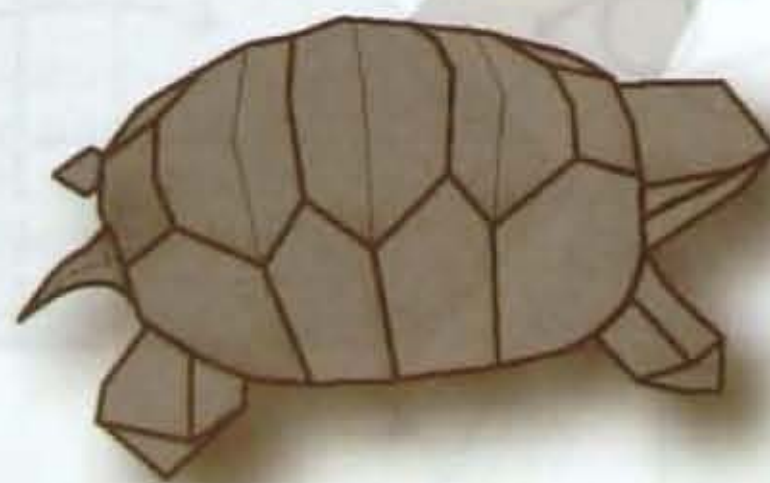

24. FINISHED! ENJOY IT!
完成!

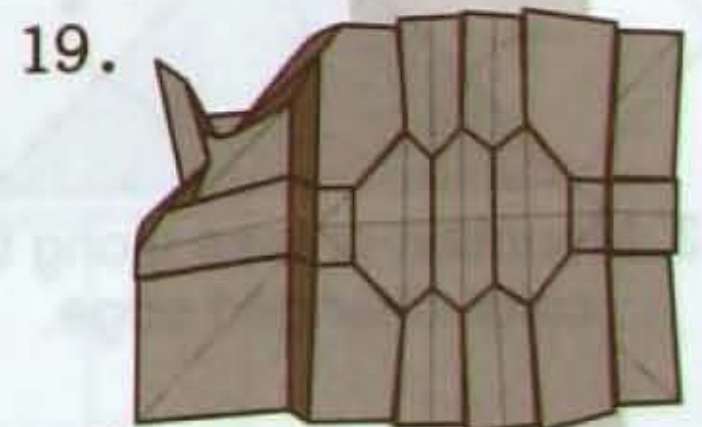

25. REPEAT STEP
17 - 18
重複步驟17-18



26. CLOSE IT
合上

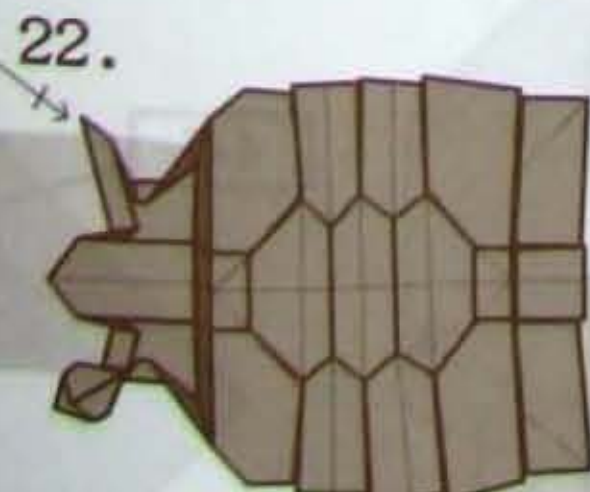

27. REPEAT STEP
21 - 22
重複步驟21-22

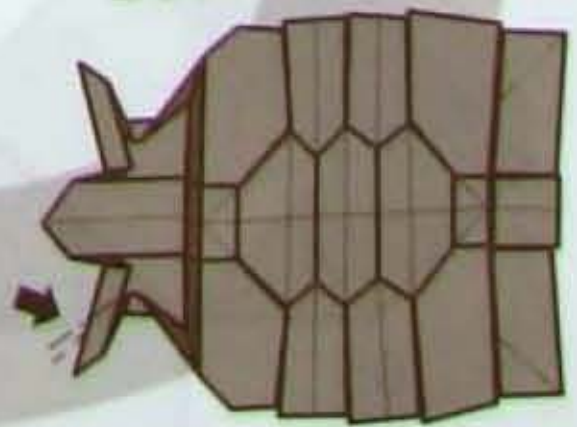
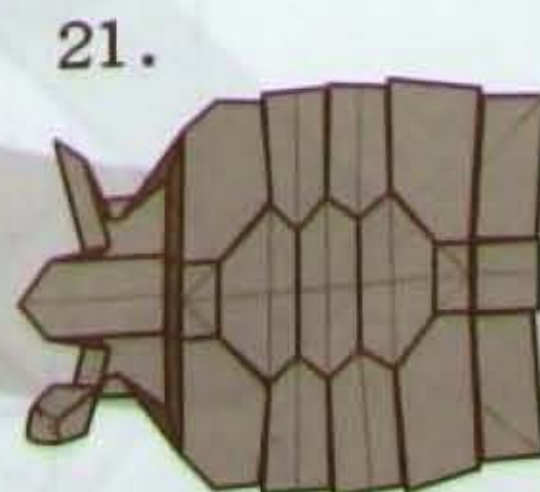

build your own HOUSE

in 20 easy steps

Román Díaz

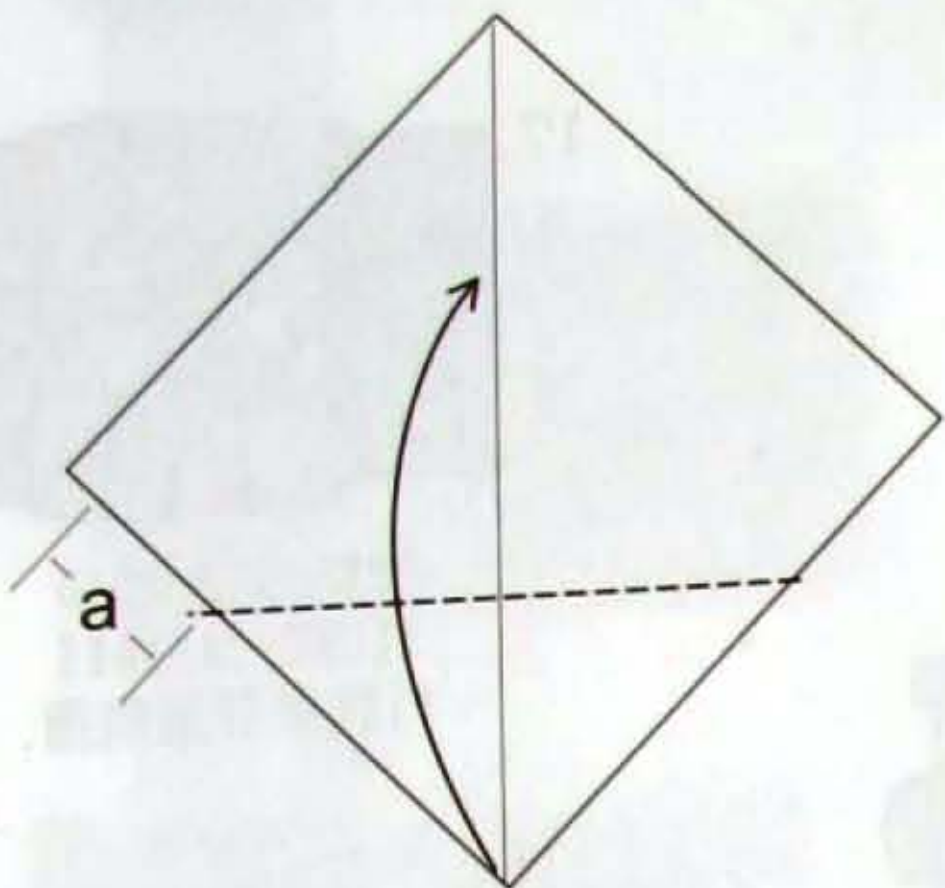
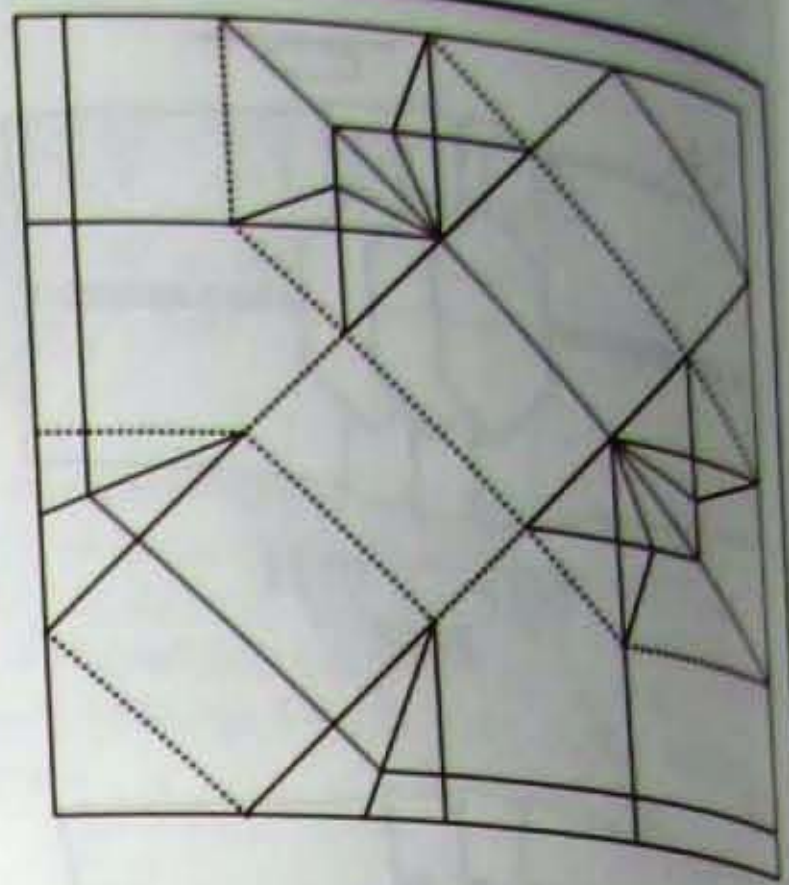
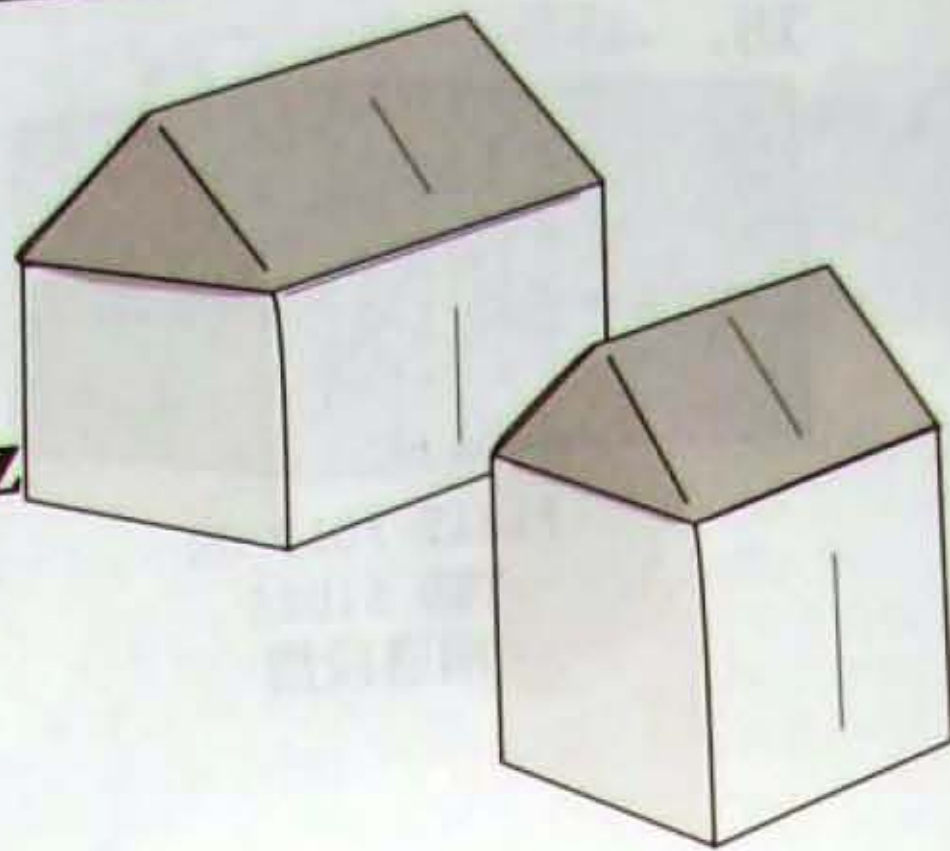

1. Intuitive reference. This is how tall your house will be.

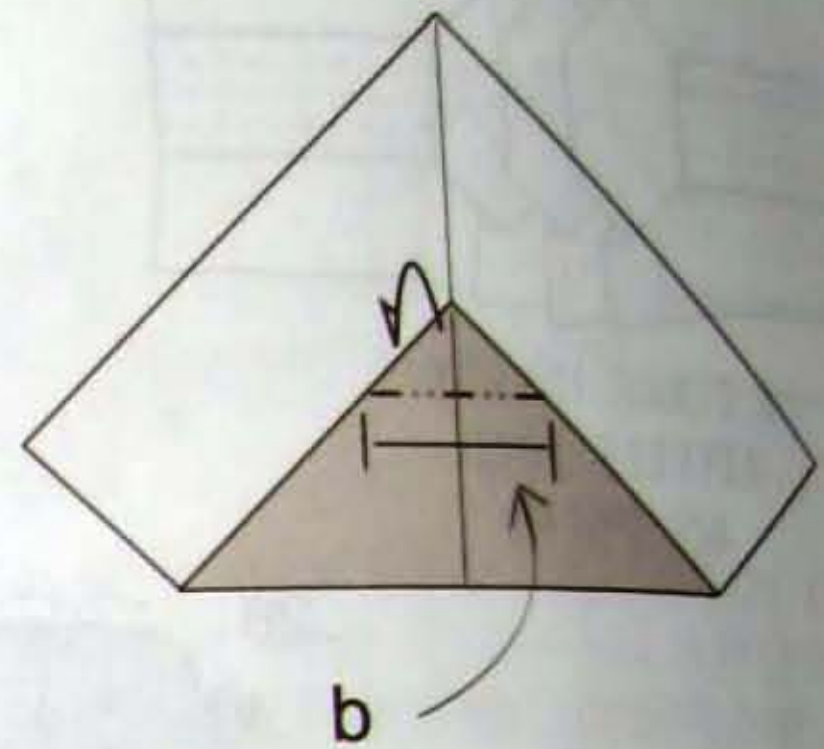
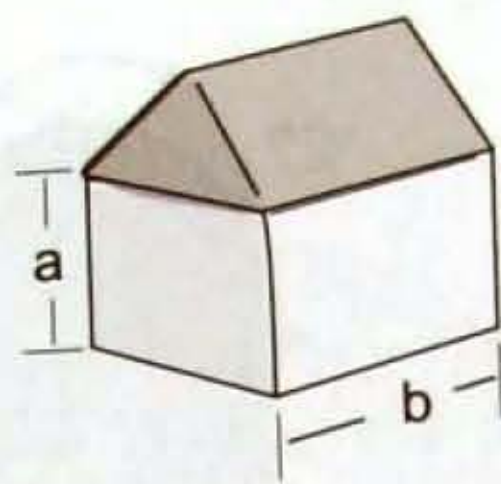

2. Intuitive reference. This is how long your house will be.

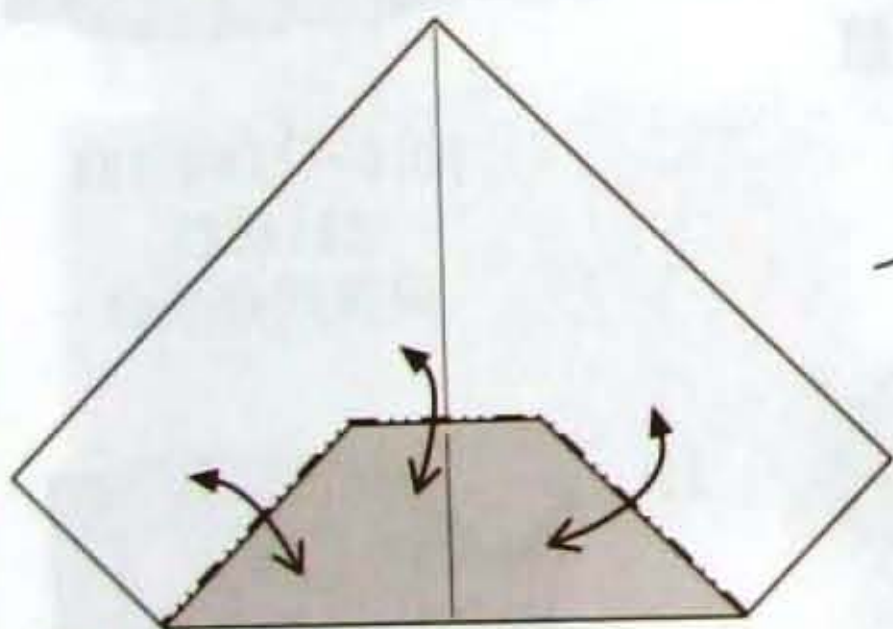

3. Mountain-crease along the color-changed edge.

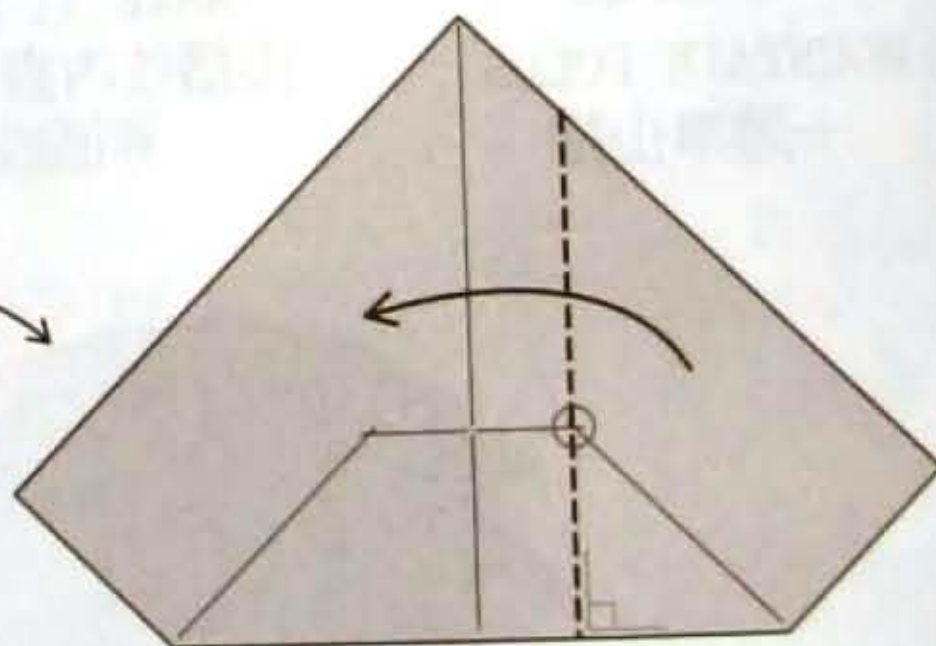

4.

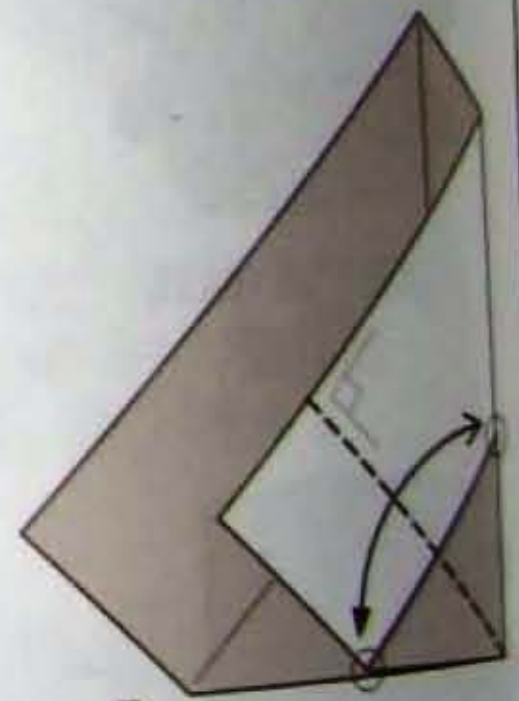

5.

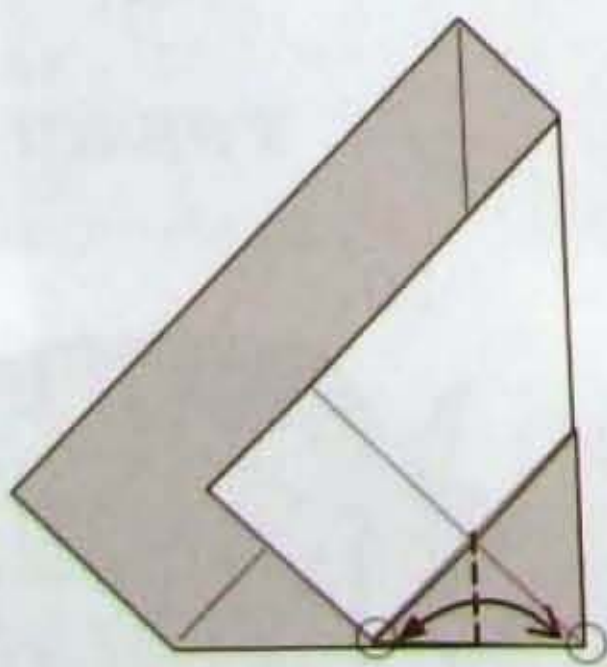

6.

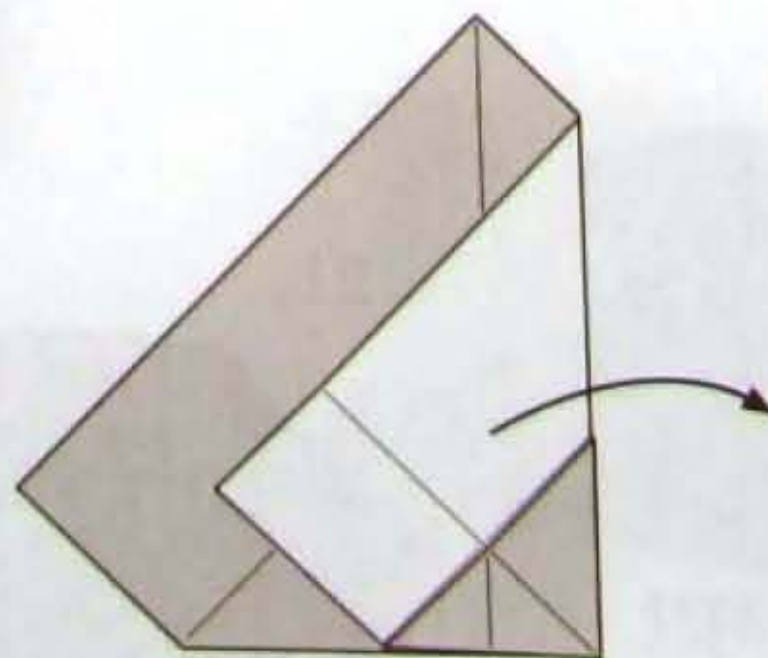

7.

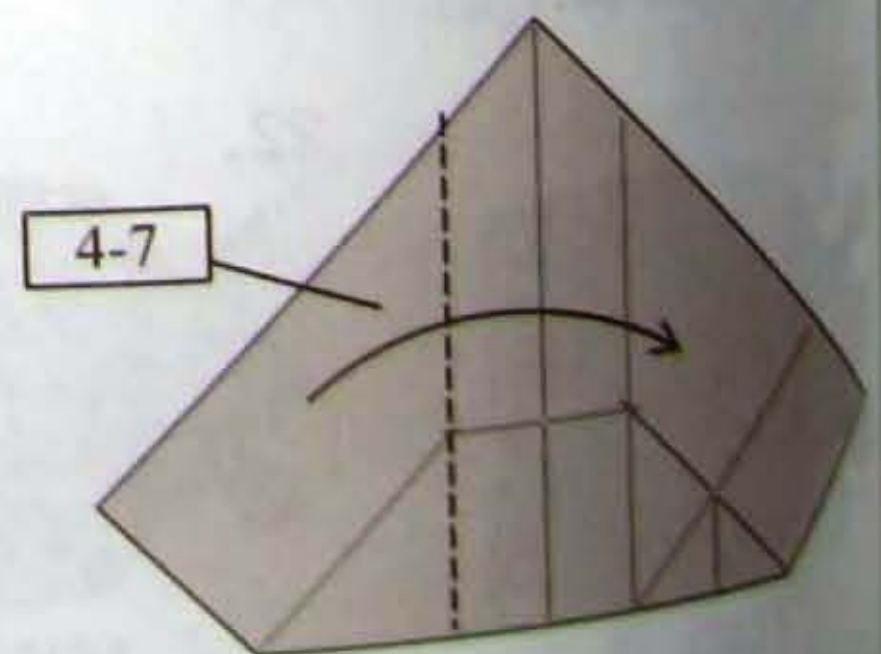

8.

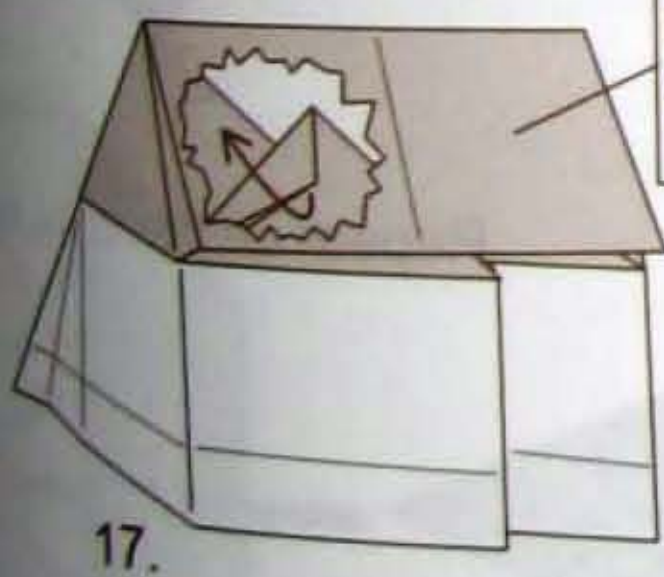
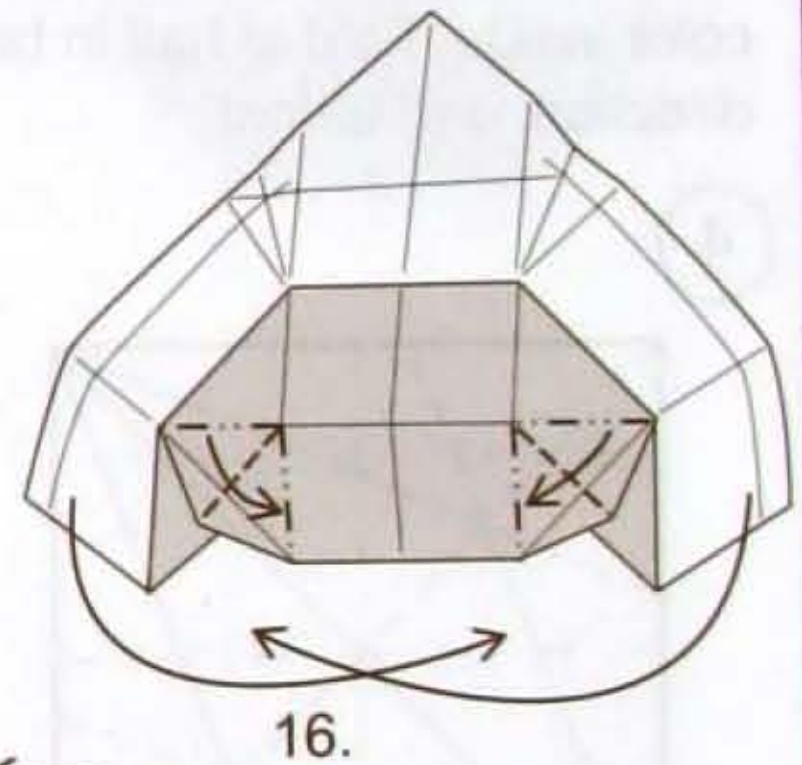
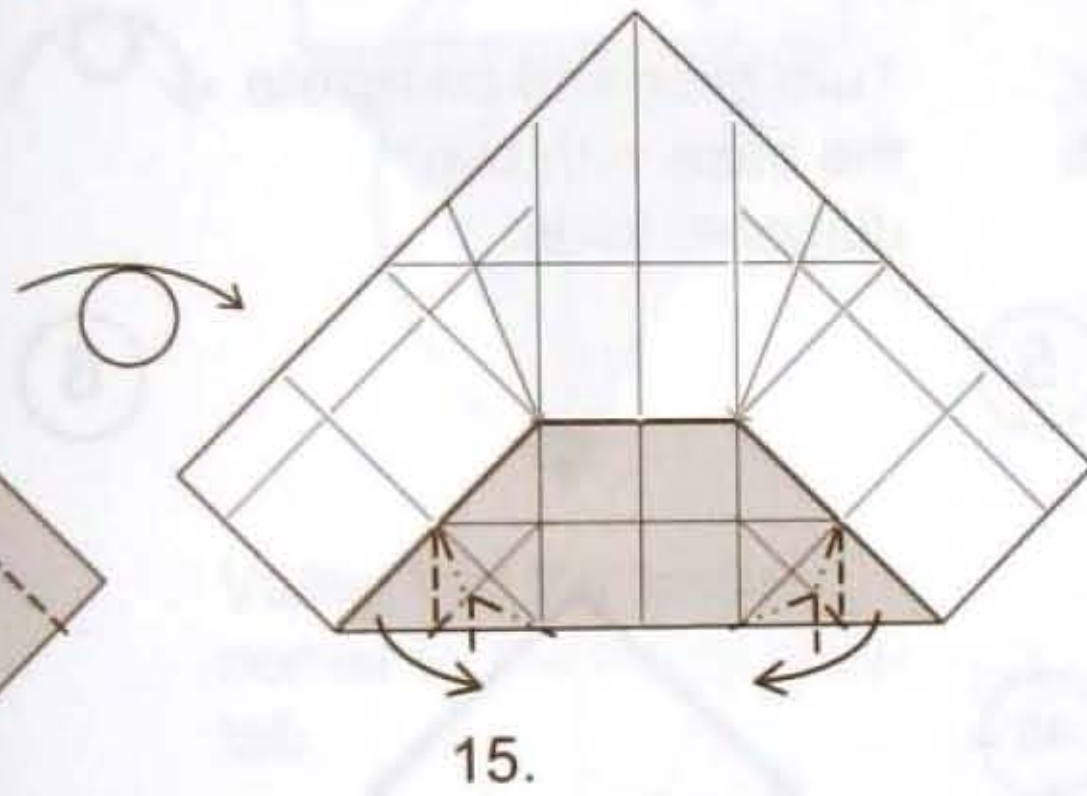
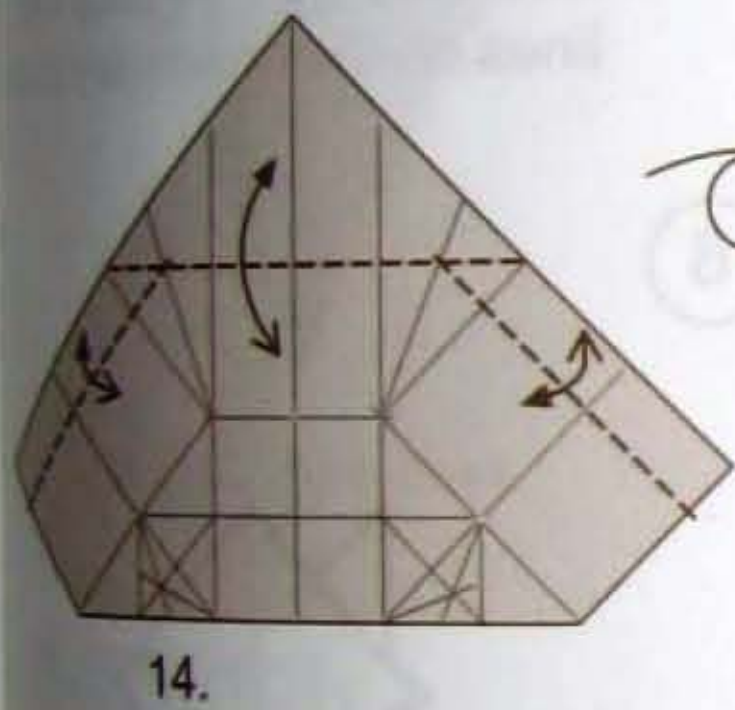
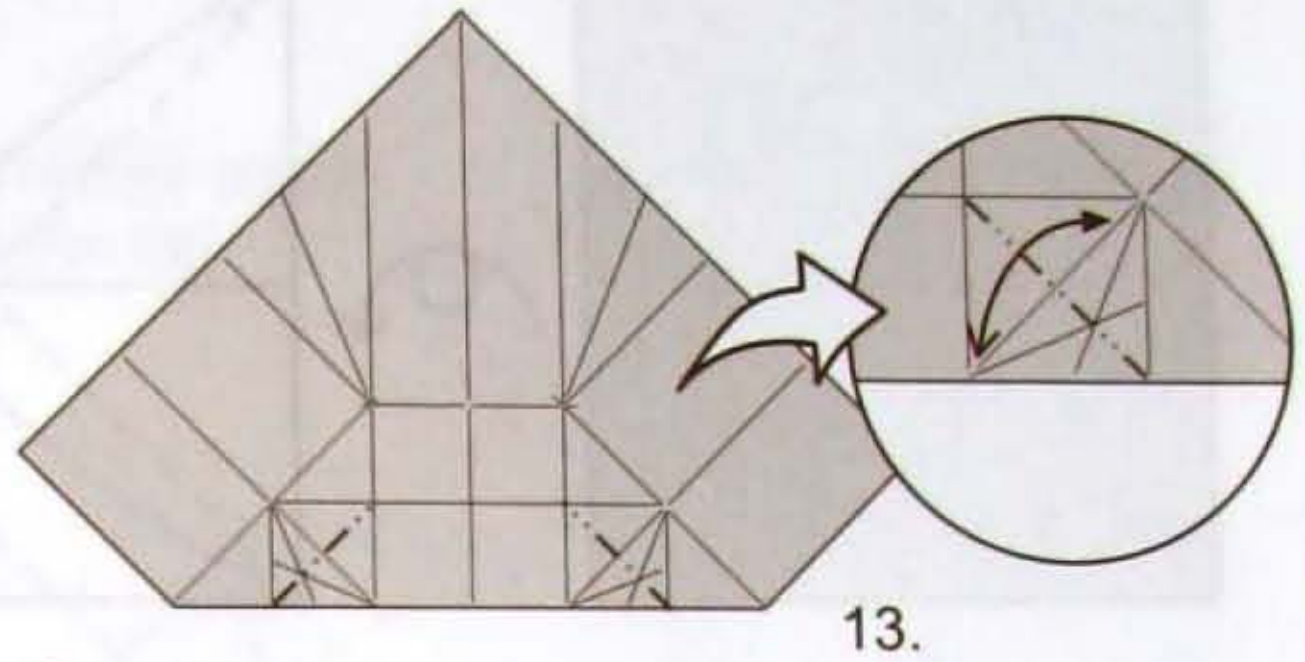
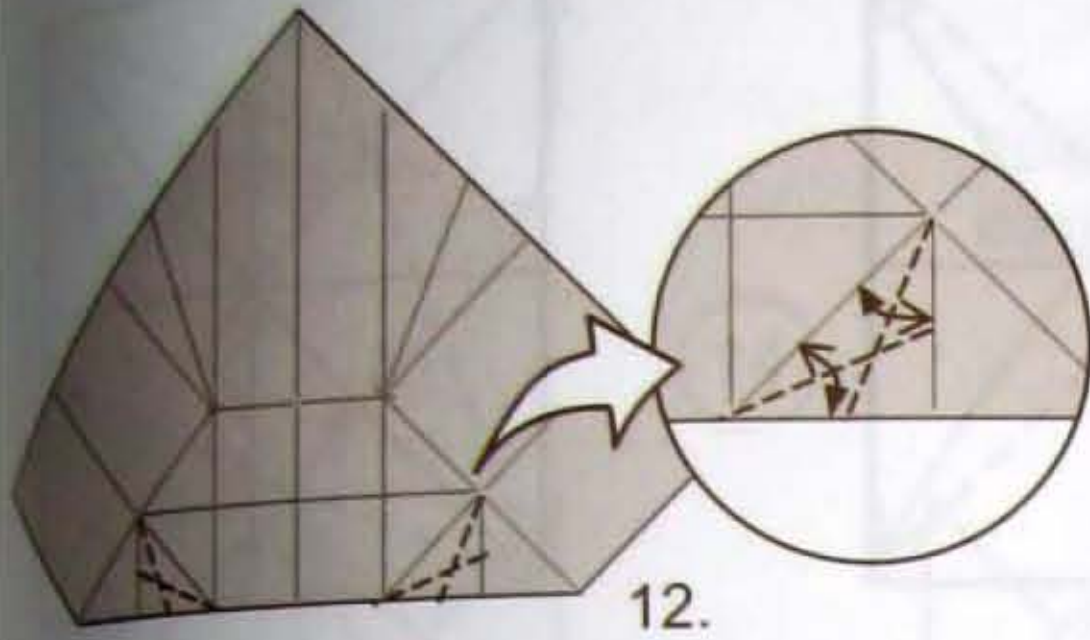
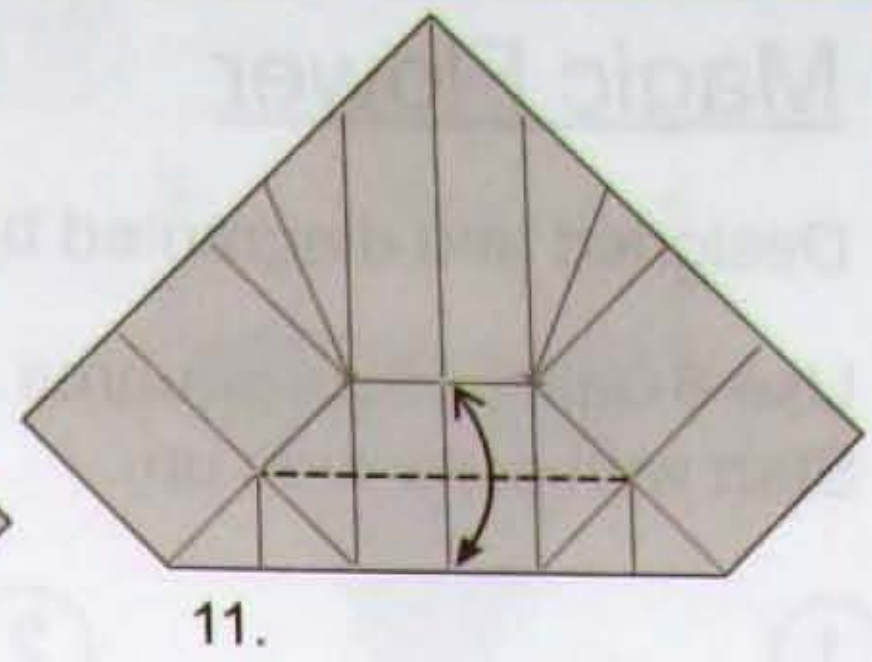
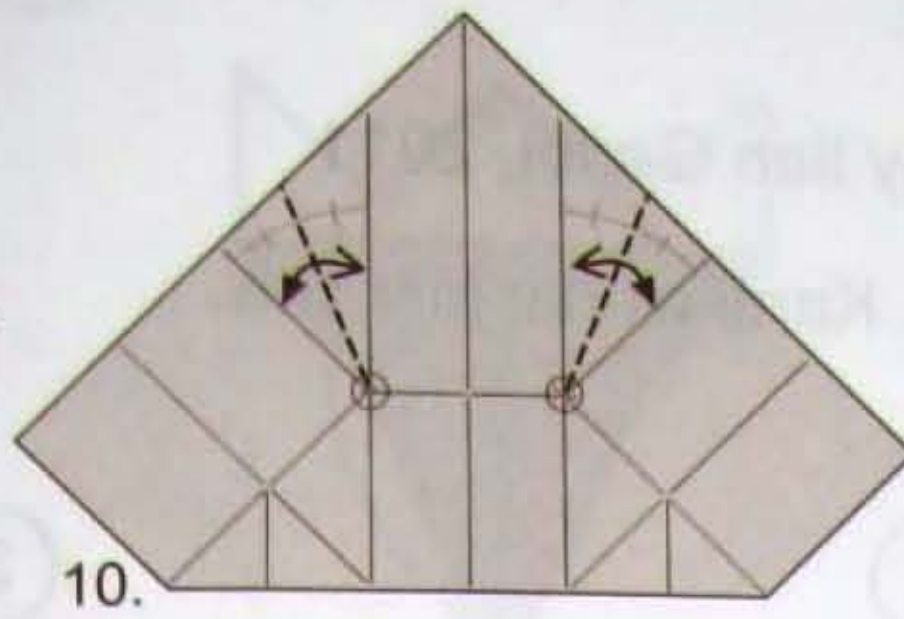
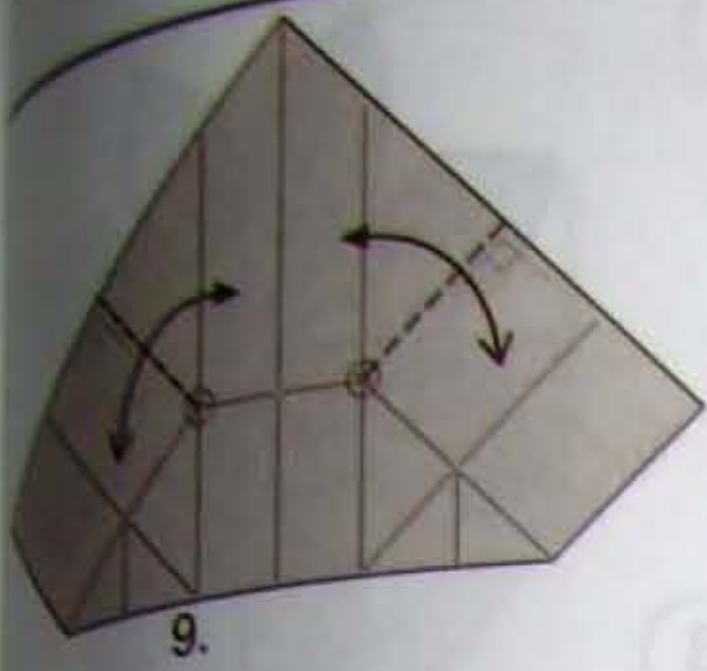

Do the same thing on the other half of the roof.

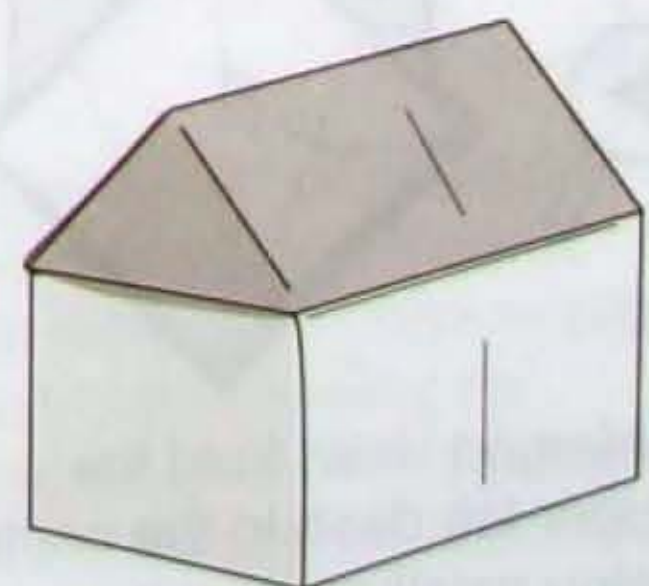
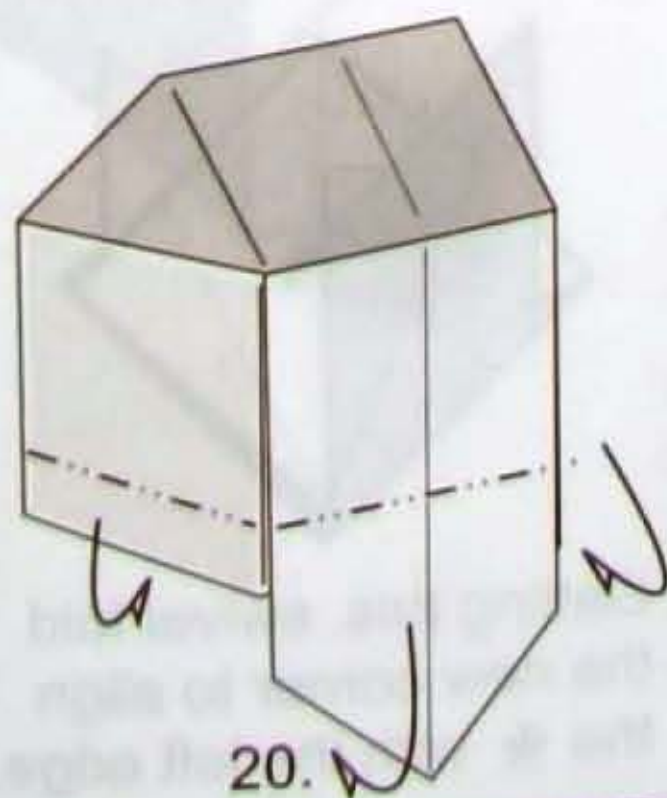
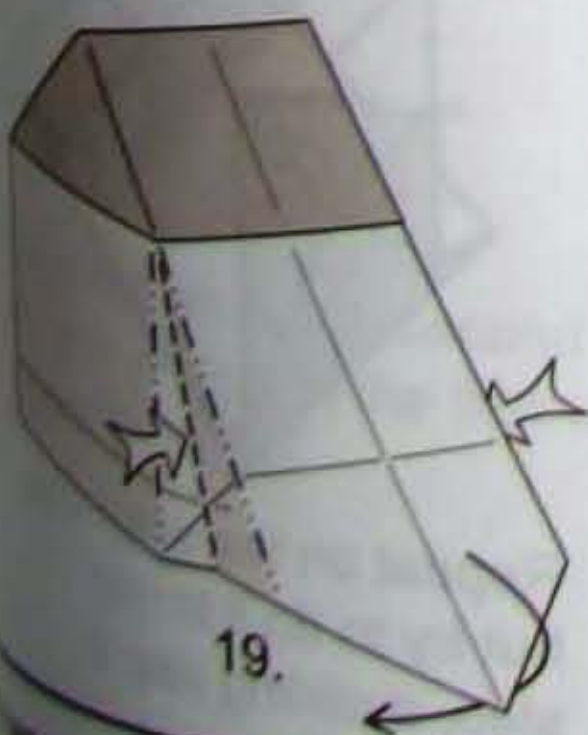
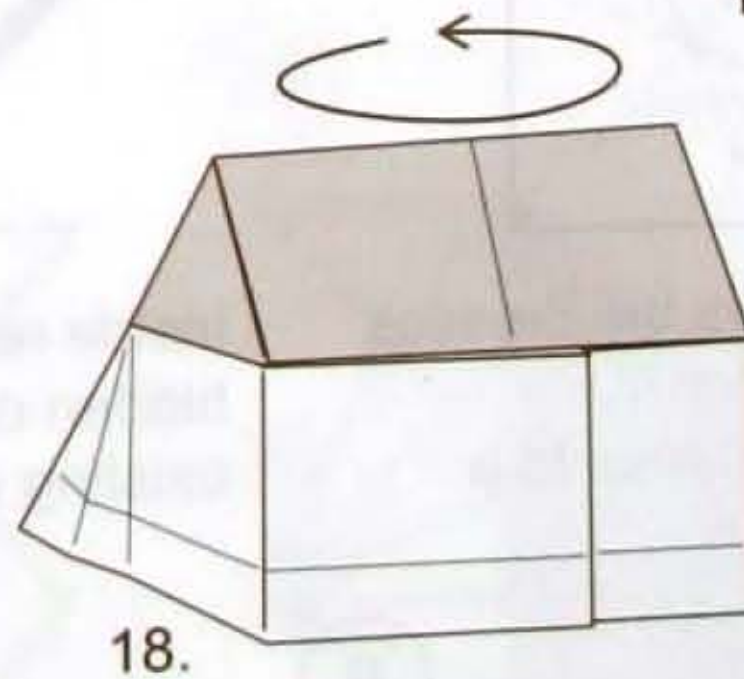

Magic Flower

Designed and diagramed by Ilan Garibi, 2011

Use 8 units, 15cm squares. Kami works just fine.
Start with color side up.

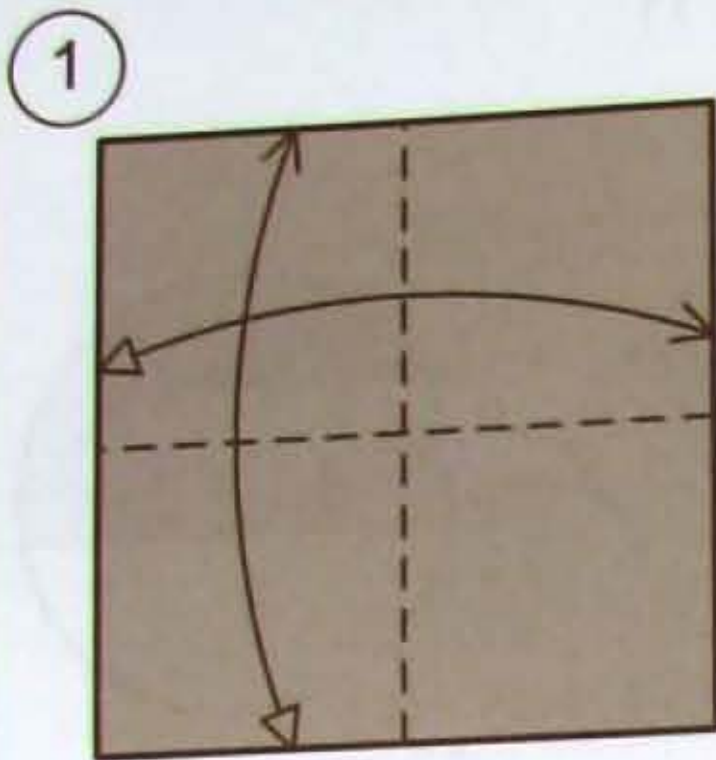

1 Start to fold a preliminary base, color inside. Fold in half in both direction, and unfold.

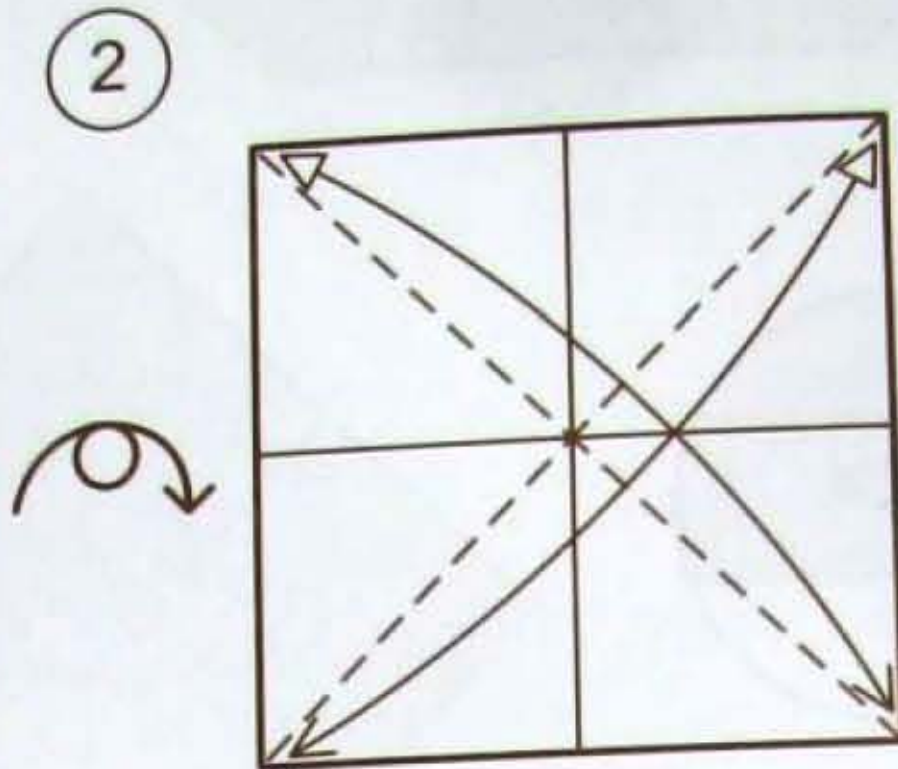

2 Turn over and complete the base with two diagonal folds.

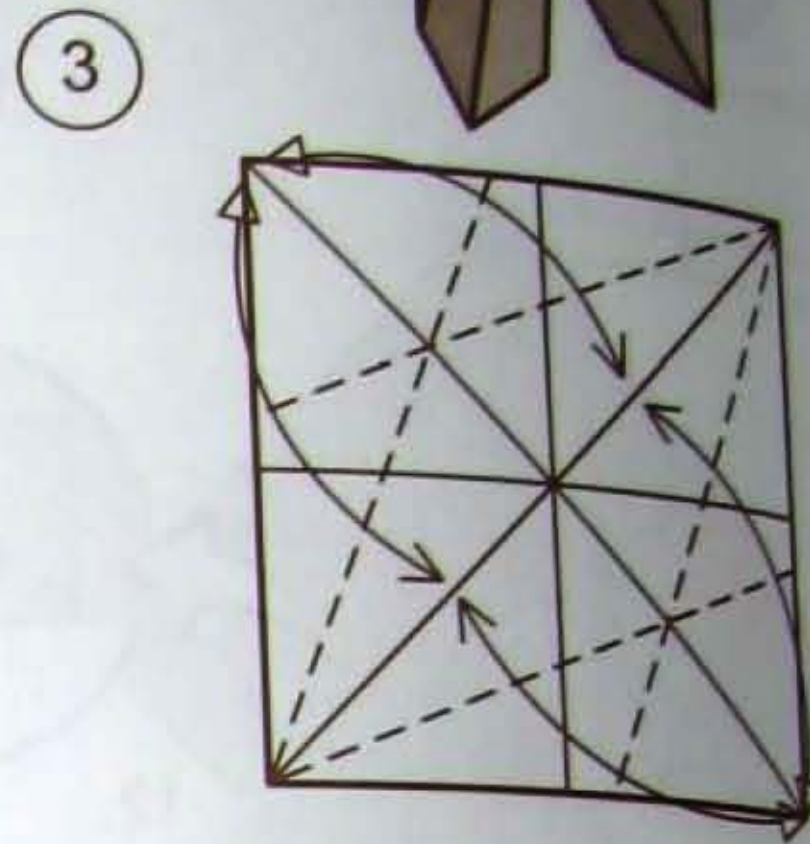

3 Now add the Fish base fold lines on the preliminary base.

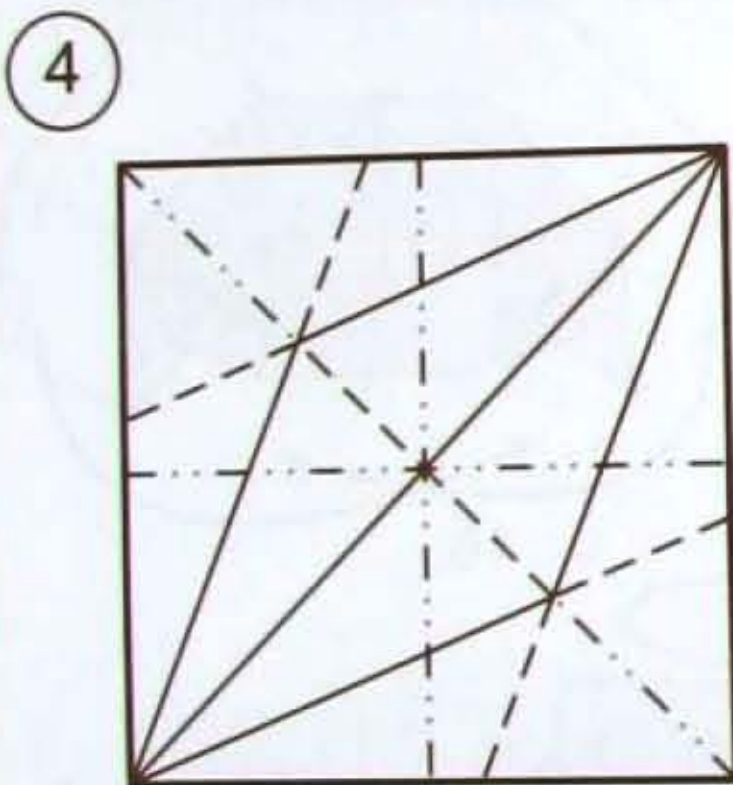

4 The CP here shows the creases to get directly to step 7. Otherwise, just collapse to a preliminary base.

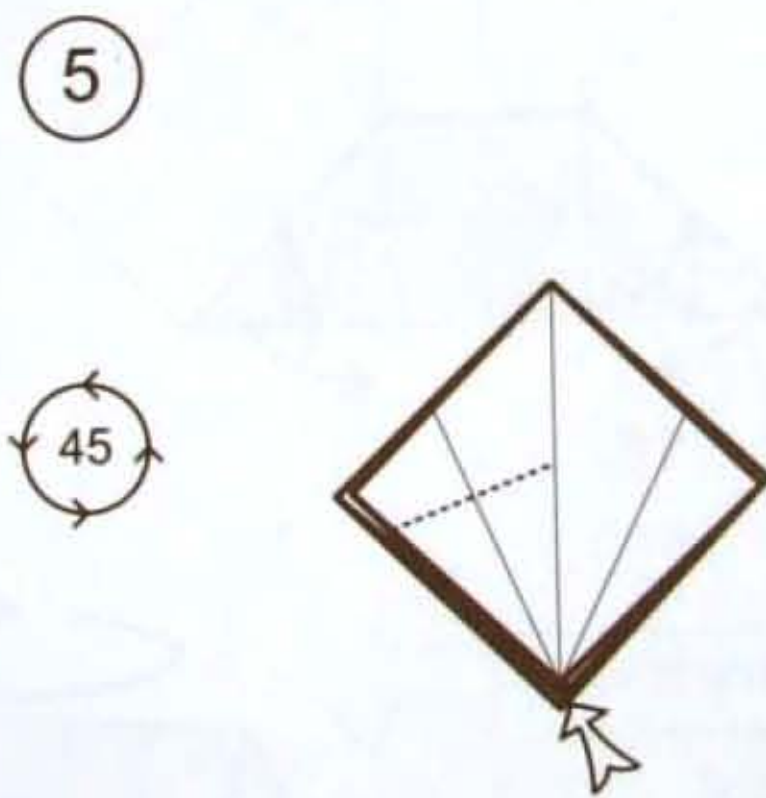

5 Inside reverse fold the hidden corner. Use existing creases only!

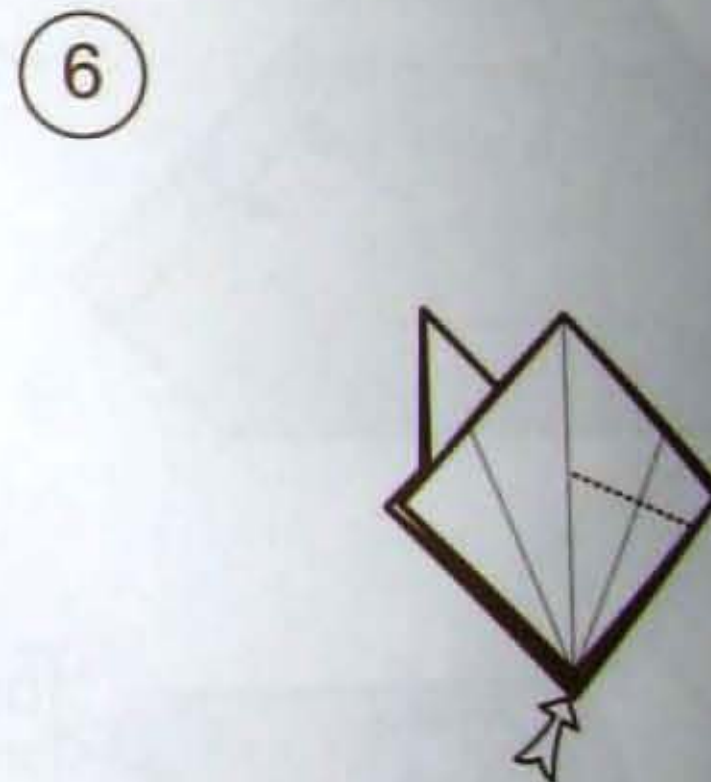

6 Repeat on the right side.

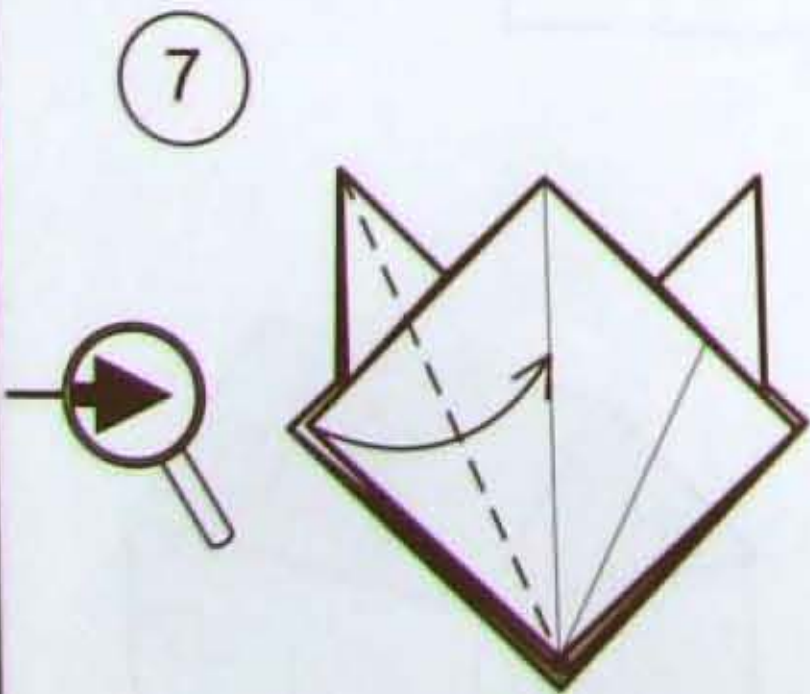

7 Enlarged view. Fold the upper left dash to the center, using existing crease.

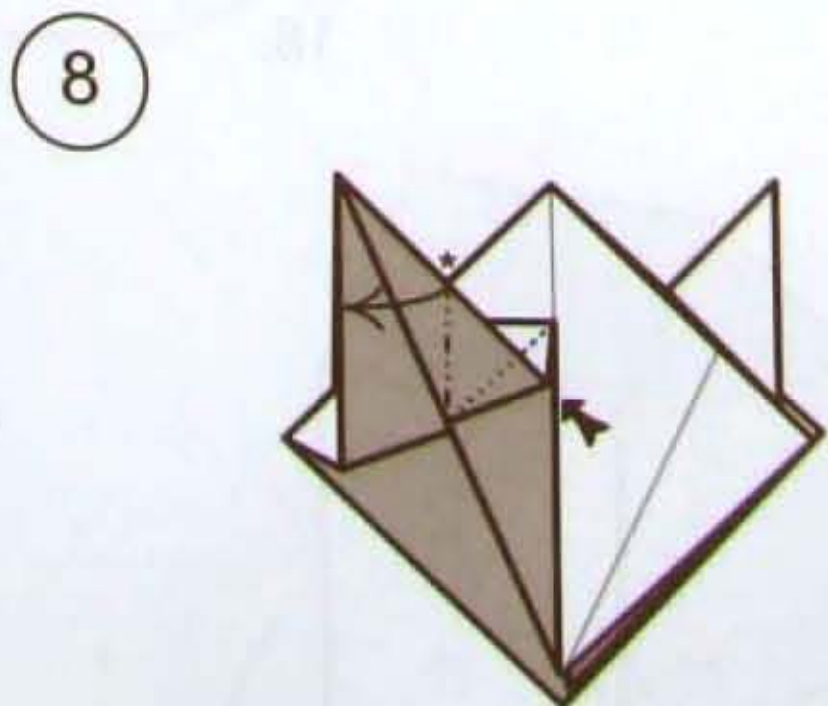

8 Getting this, swivel fold the new corner to align the * with the left edge.

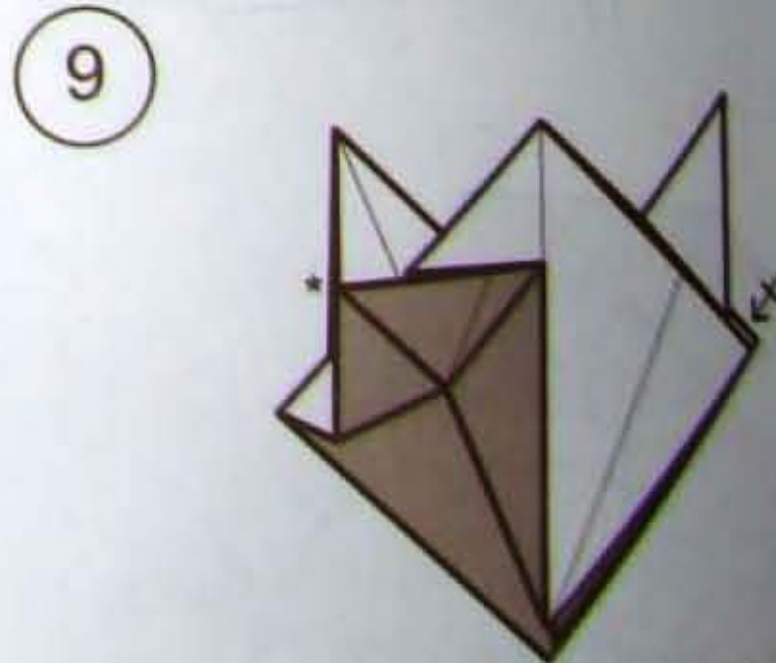

9 Repeat on the other side but try to do it in one step, avoiding step 8.

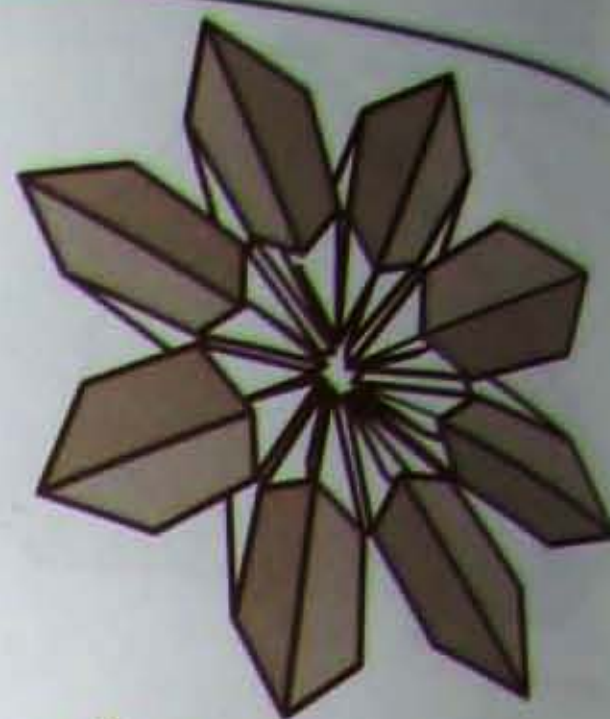

10

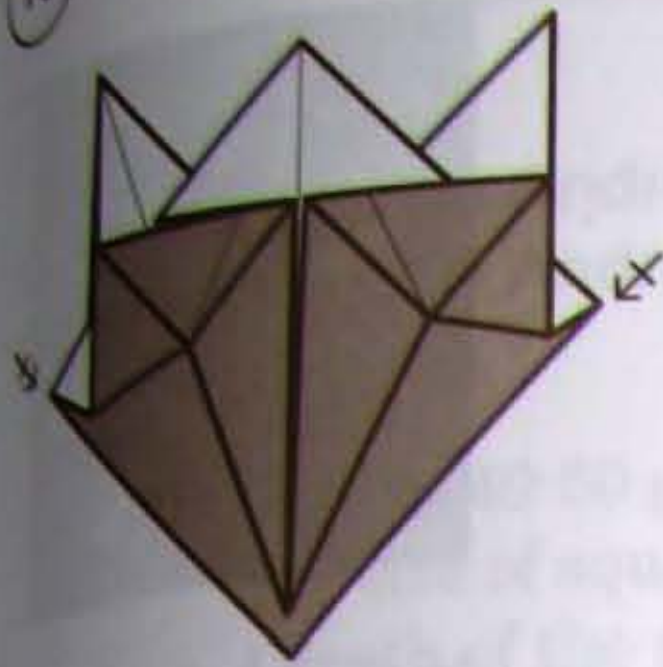

Repeat behind.

11

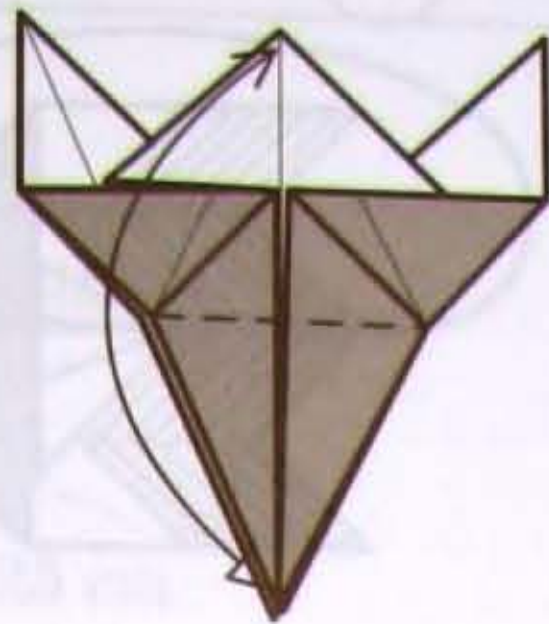

Fold and unfold bottom corner to the top.

12

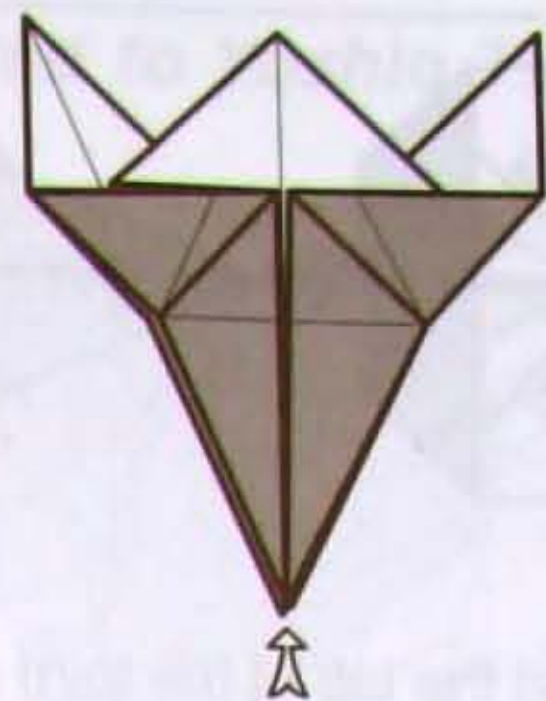

Sink the bottom corner to create a pocket.

13

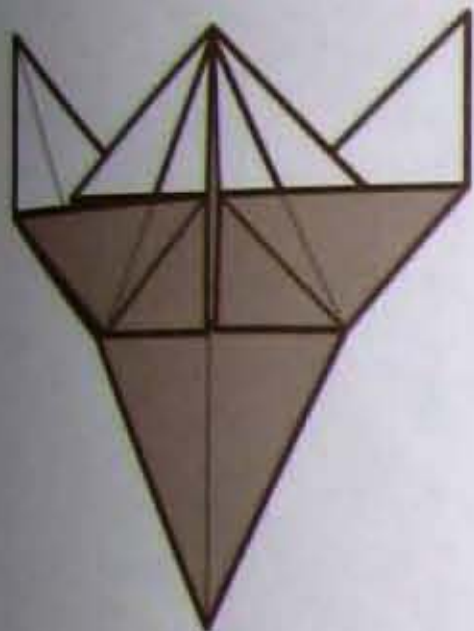

Like that. Turn over.

14

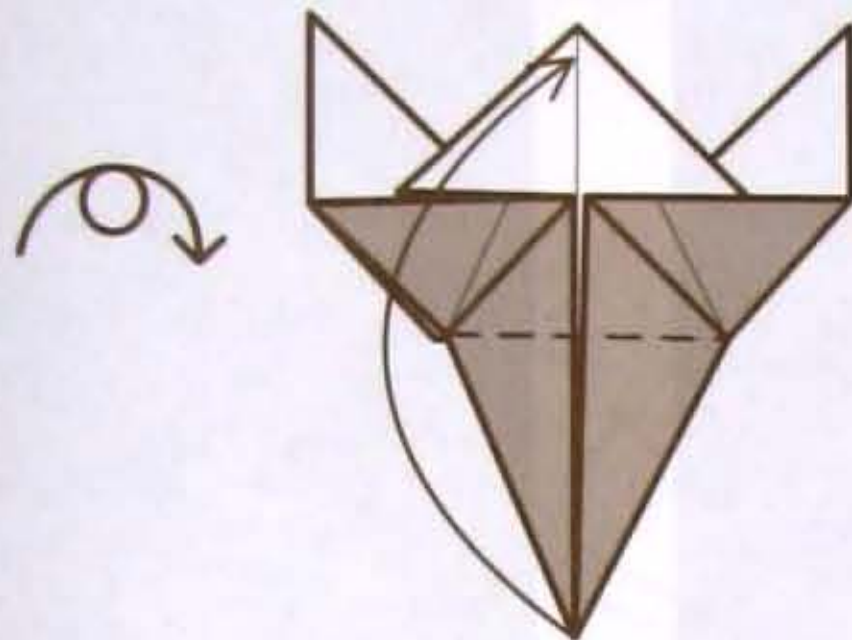

Valley fold the bottom corner to the top to get a tab.

15

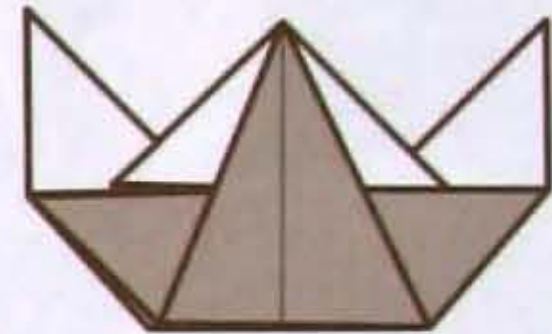

This is the final unit.

Assembly

15

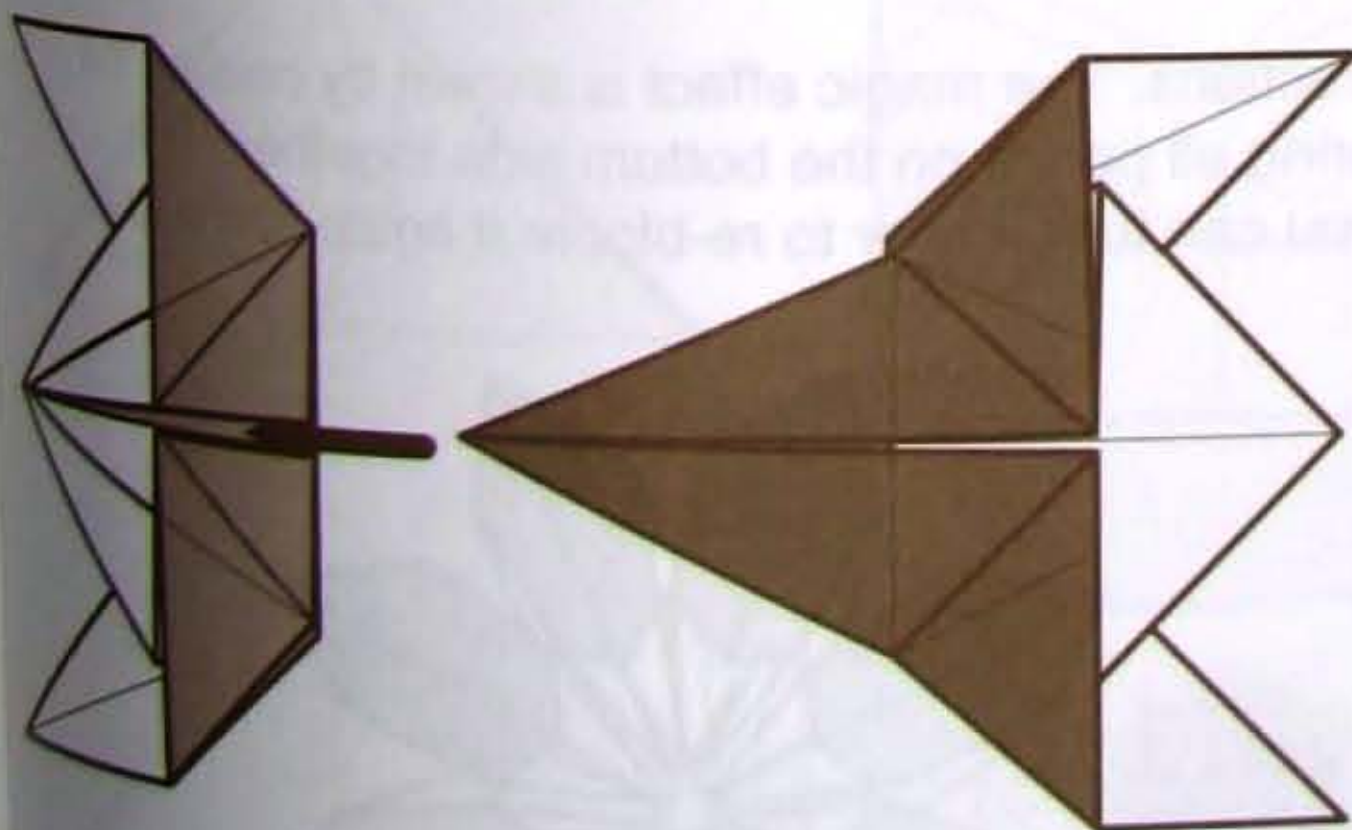

Insert the tab of the second unit into the pocket of the first unit, corner to corner.

16

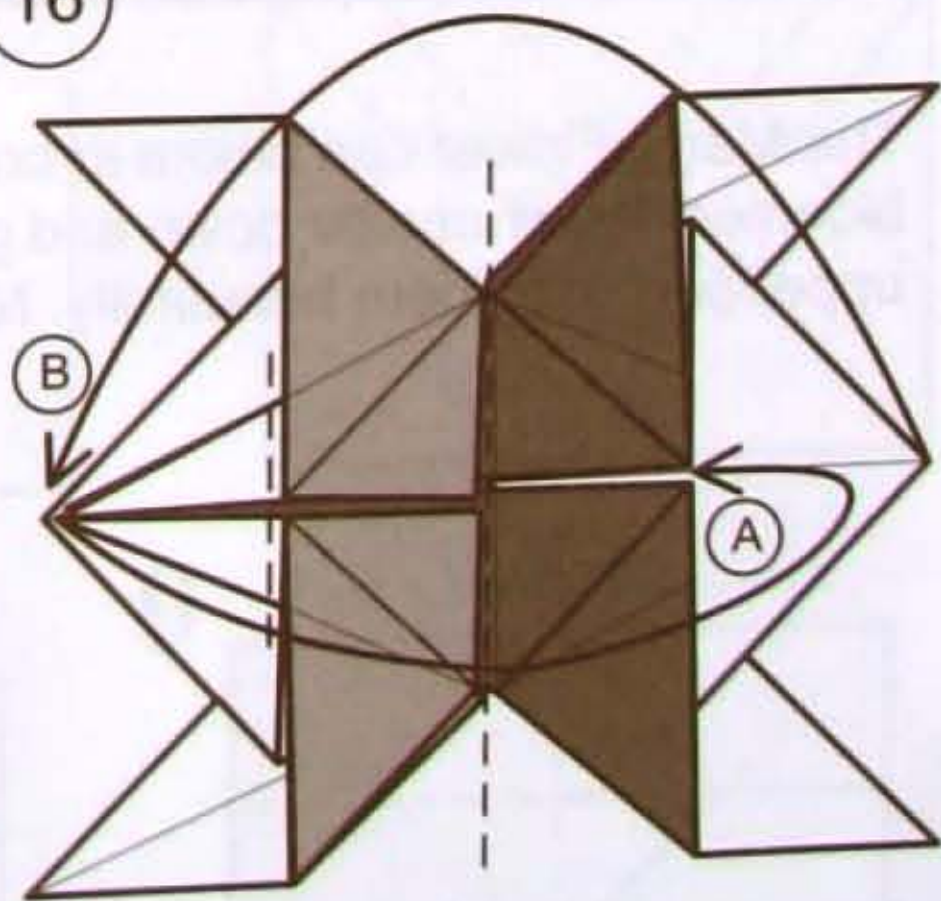

To lock, fold the left combined corners to the right and insert it behind the front layer of the second unit (step A), while folding the second unit body to the left (step B), to expose the second unit pocket.

17

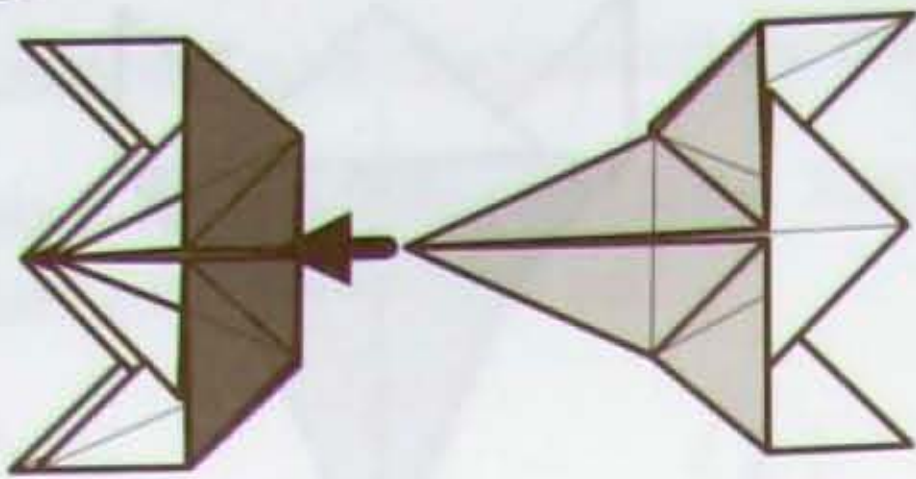

Insert the tab of the third unit into the pocket of the second unit, corner to corner. Lock and fold as with the previous two units.

18

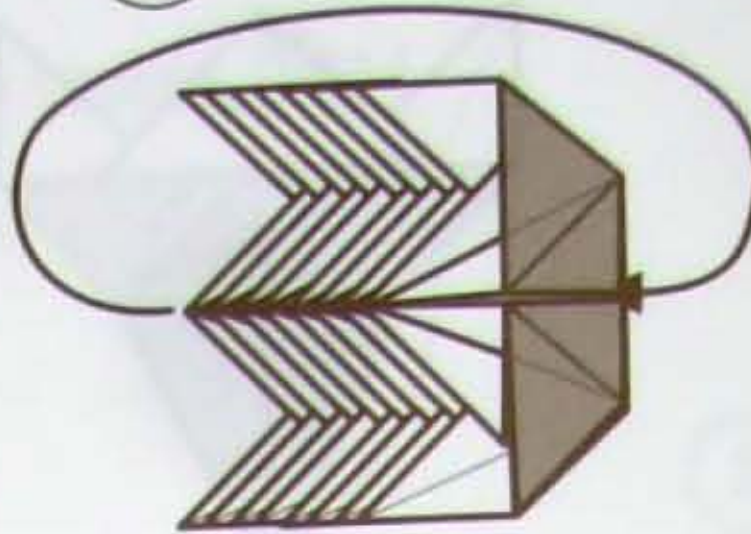

After joining 8 units, insert the first unit tab into the last unit pocket, to make a ring.

Like that.

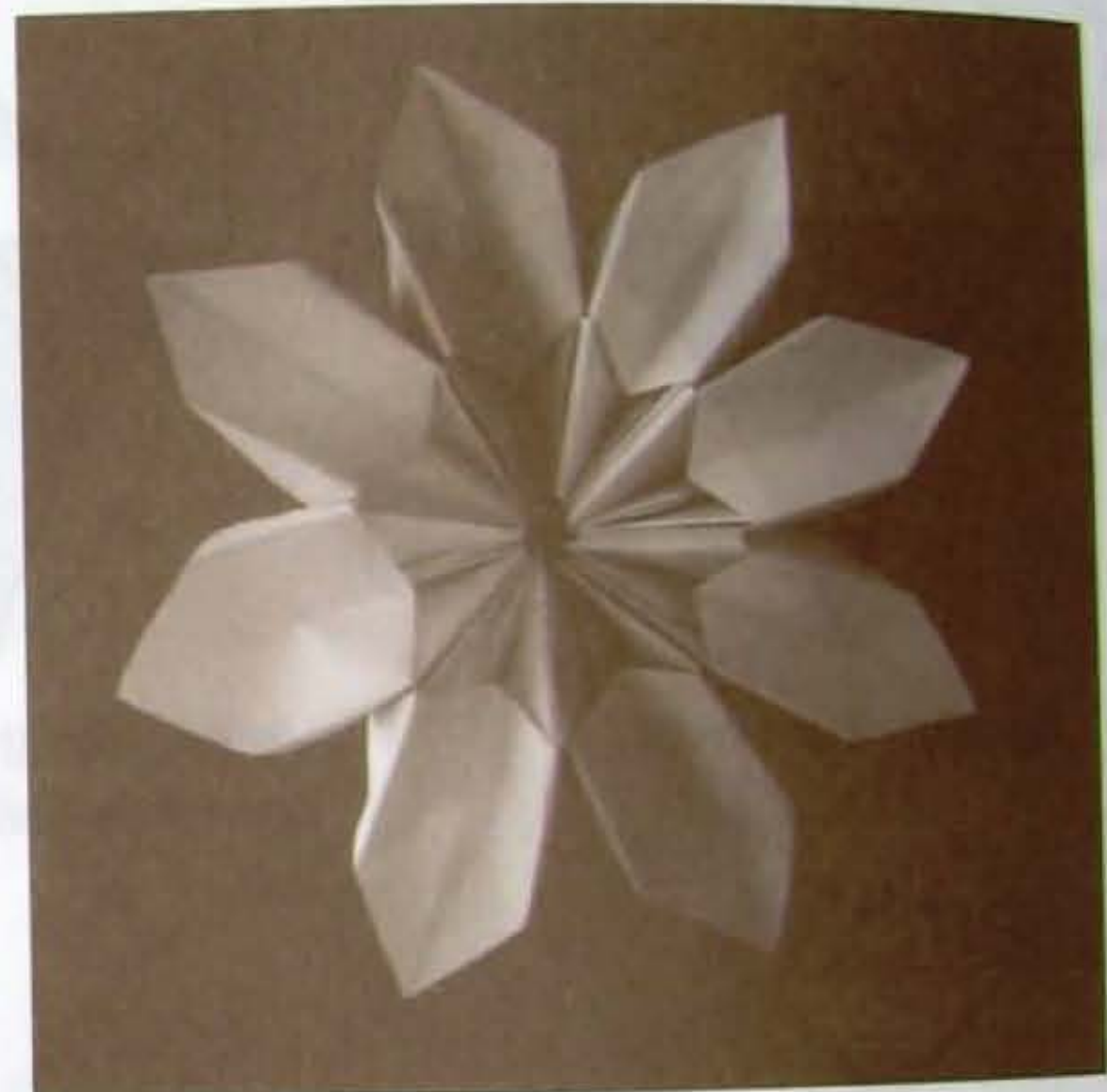
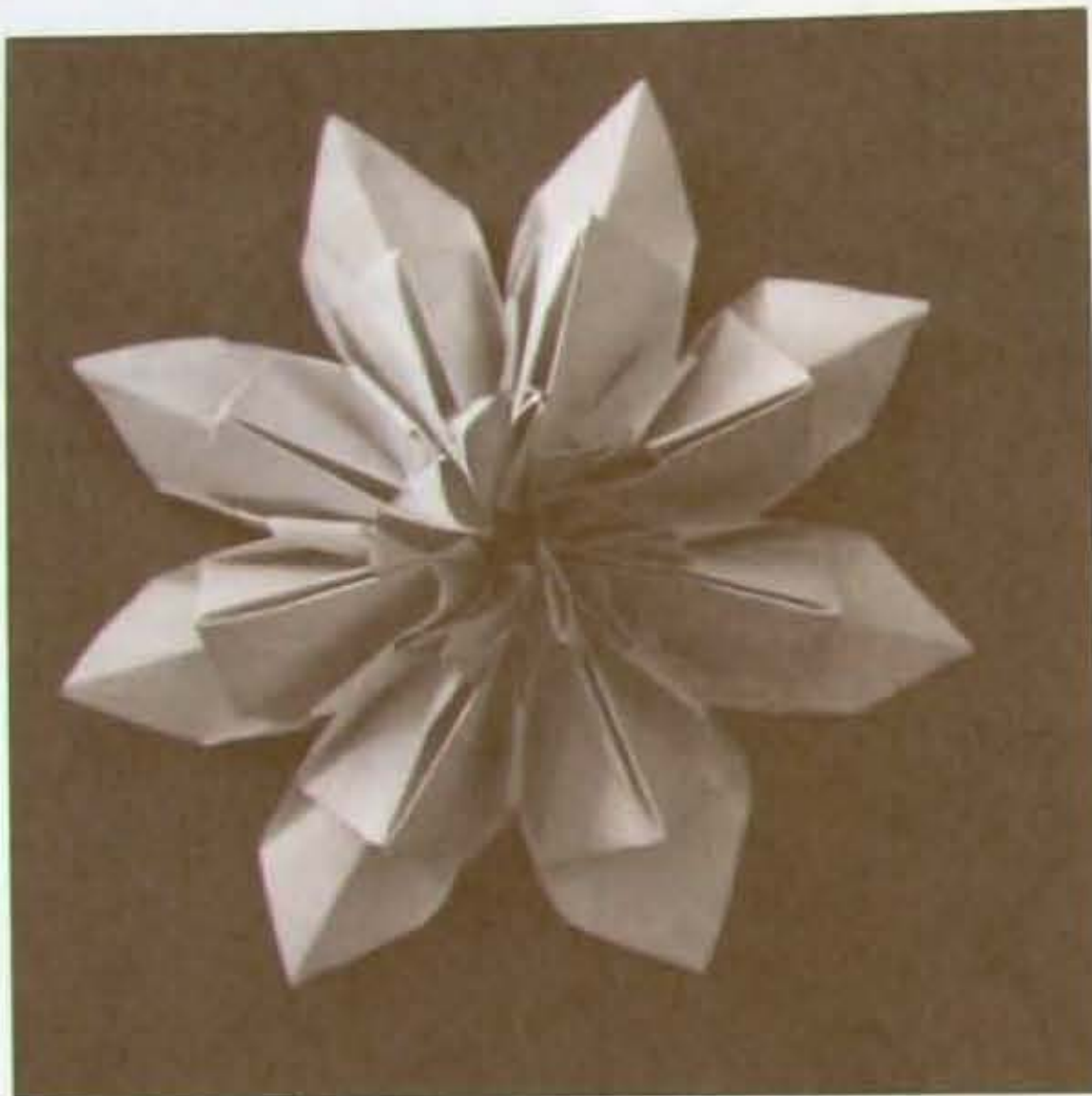
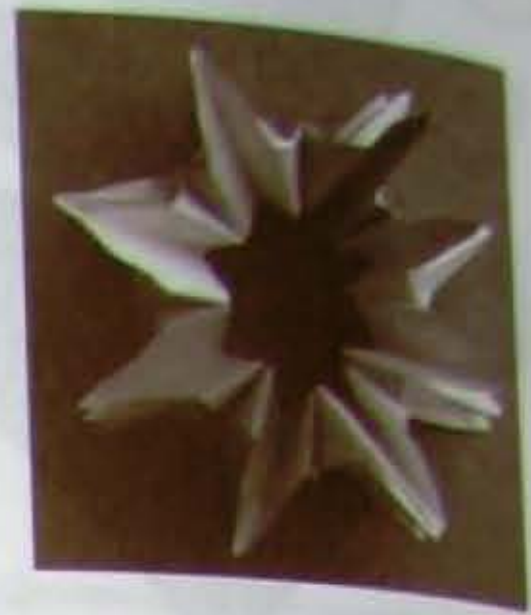

The Magic Flower can bloom in both directions. The magic effect is shown by holding the bloomed flower upside down and gathering all petals on the bottom side together. The upper part will bloom beautifully. Now you can turn it over to re-bloom it again and again!

Japão Burajirujin

www.japaoburajirujin.blogspot.com

<http://www.flickr.com/photos/garibiilan/>
garibiilan@gmail.com

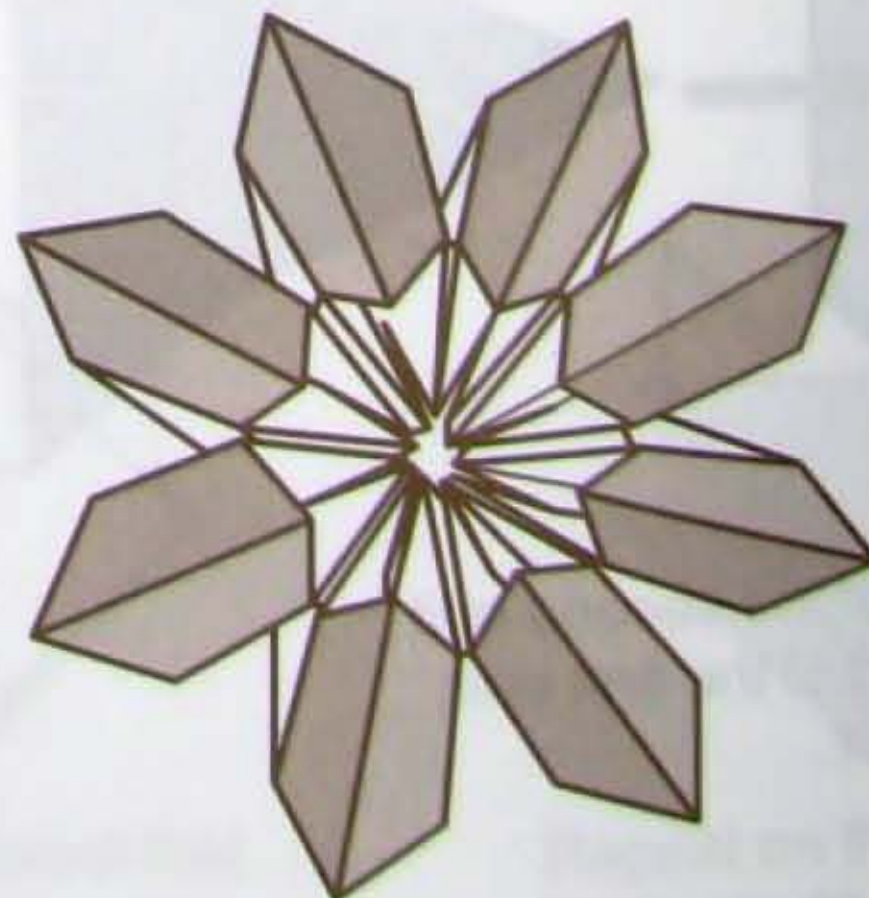

Creator:
Drawing:

3

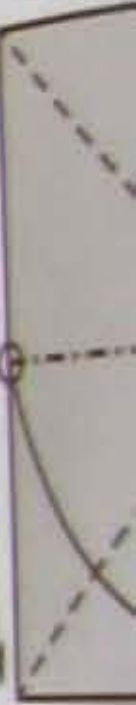

第17回折紙探偵団コンベンション折り図集 vol.17 2011年

Heart with butterfly

Devoted to Yoshio Tsuda

Creator: Lukyanov Andrey (Ukraine)
Drawing: Ermakov Andrey (Russia)

Paper : 40-50 g/m²
For size of square: 25-25 cm
Length of the model: 9,5 cm
Time to fold: 20-30 min

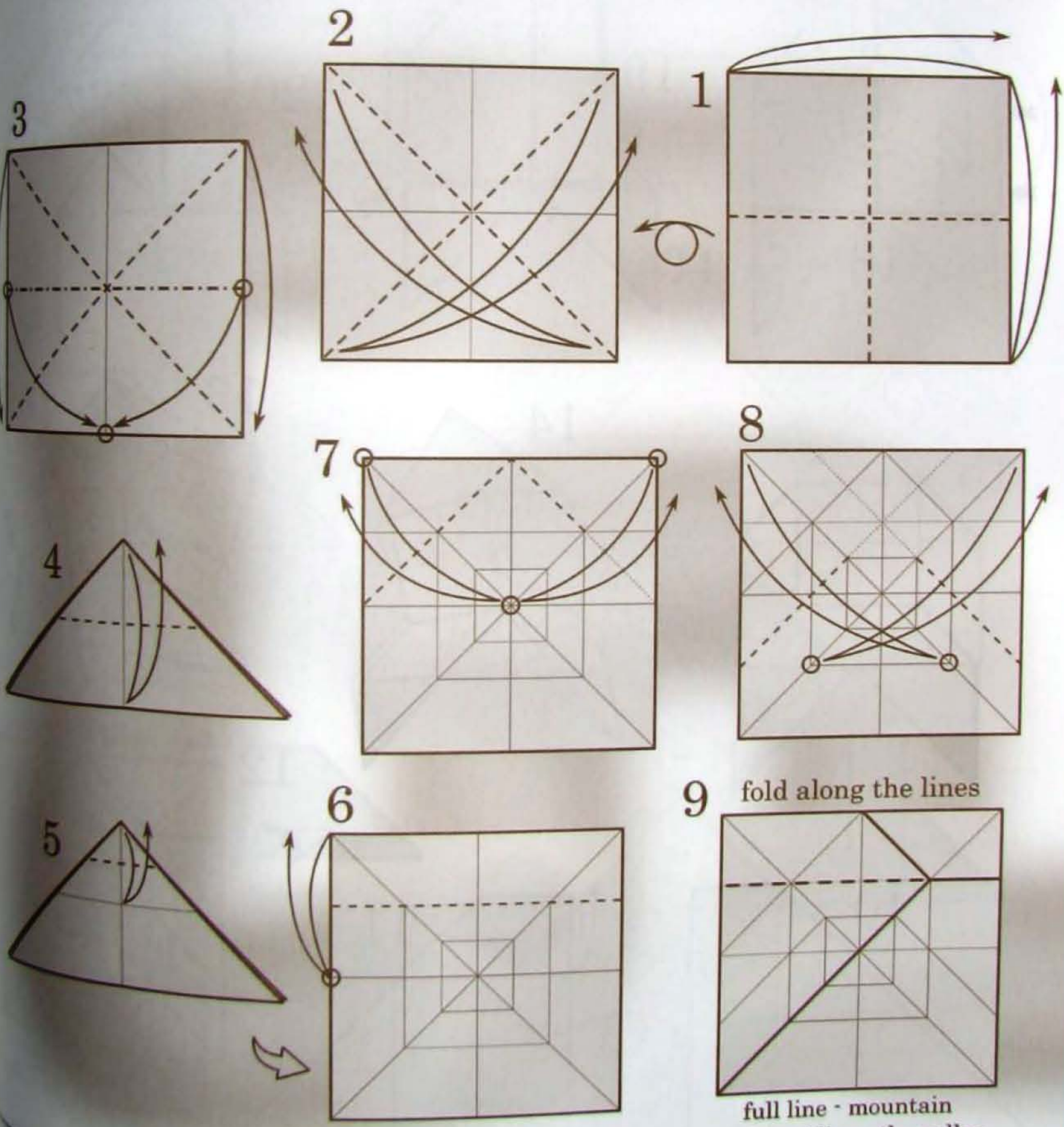
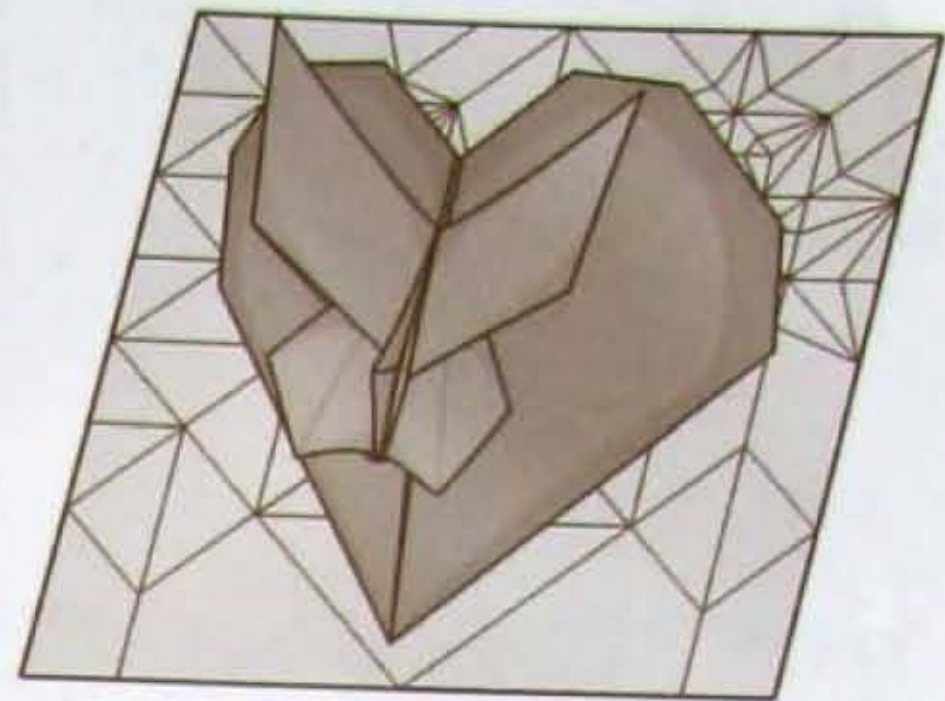

full line - mountain
dotted line - the valley

17

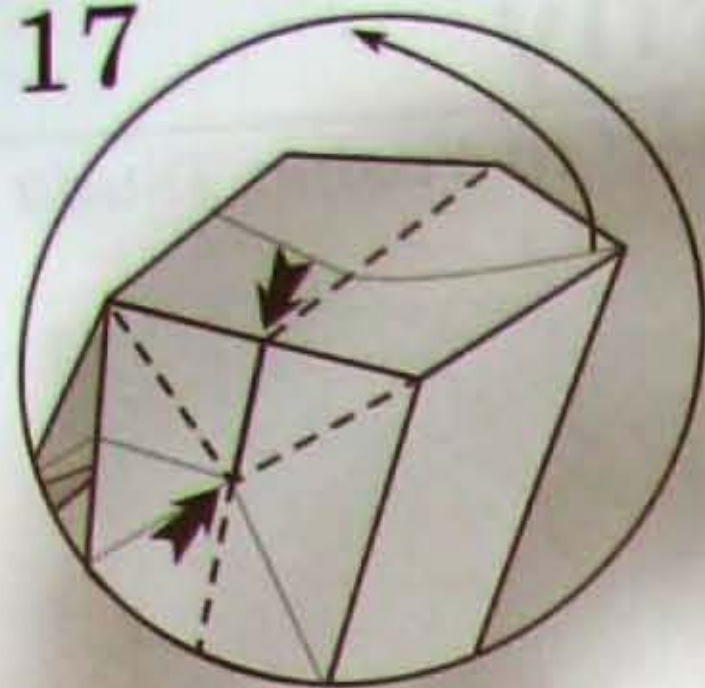

18

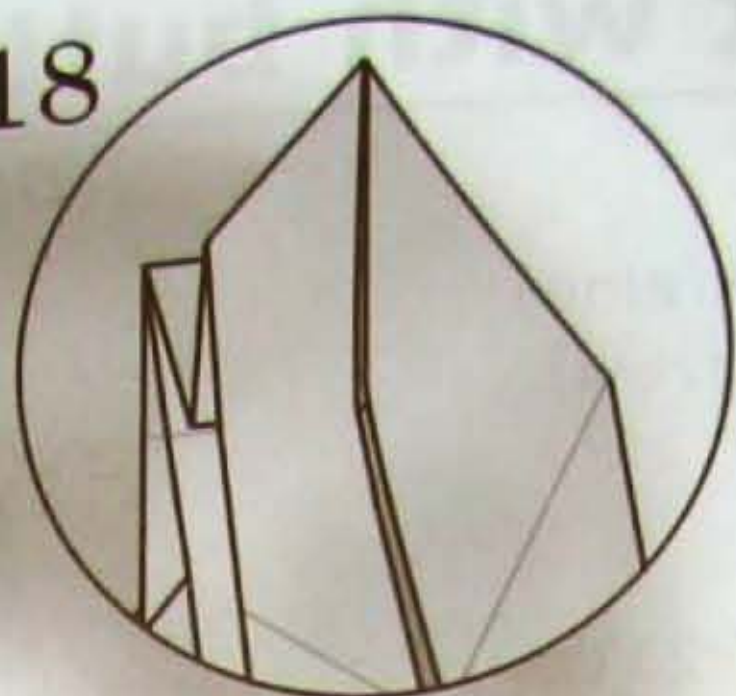

21

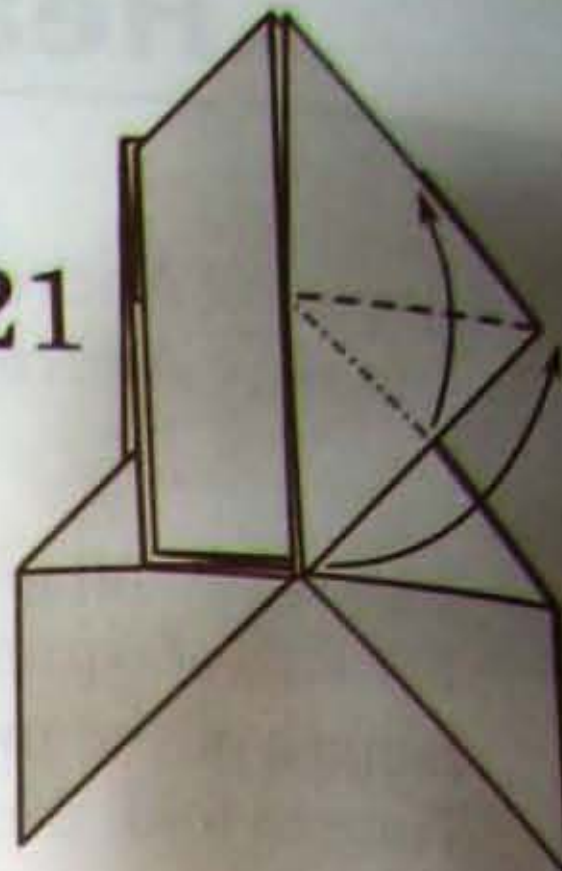

22

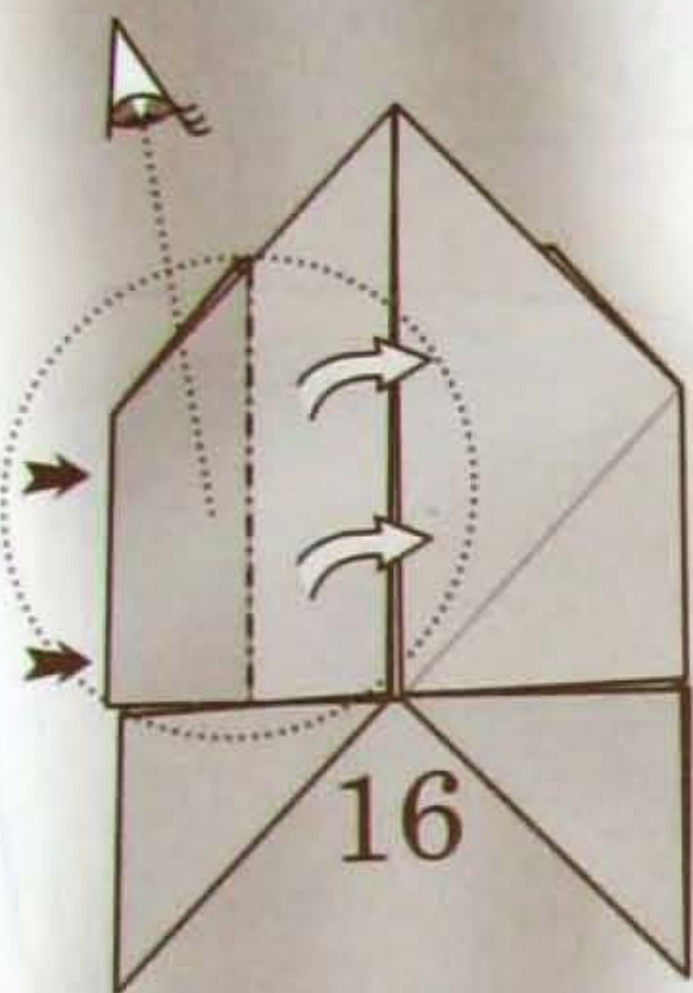

19

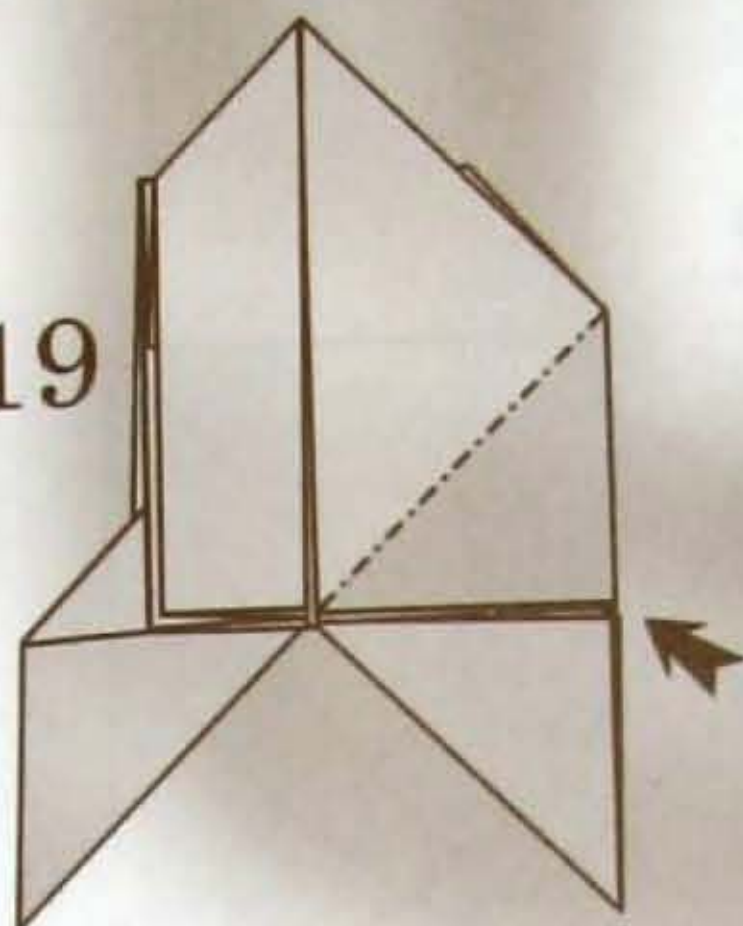

20

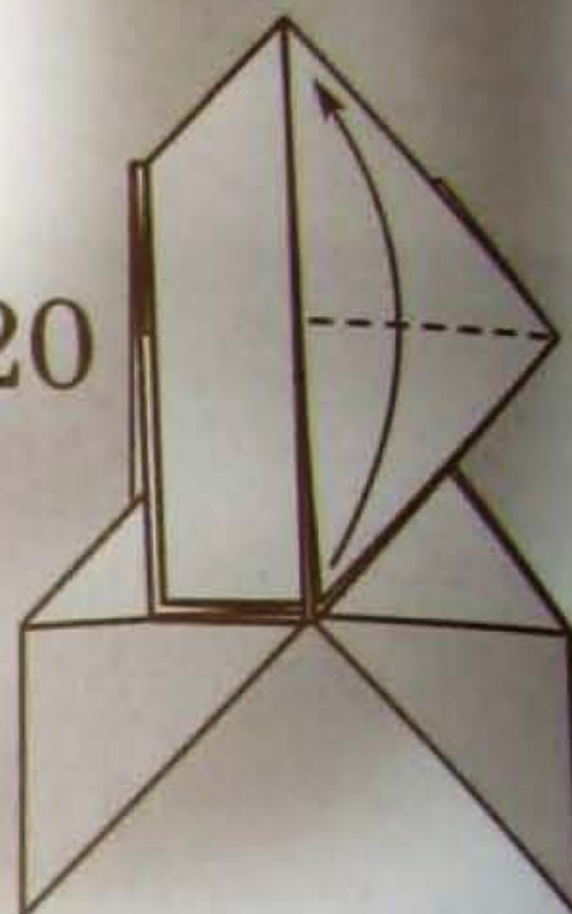

15

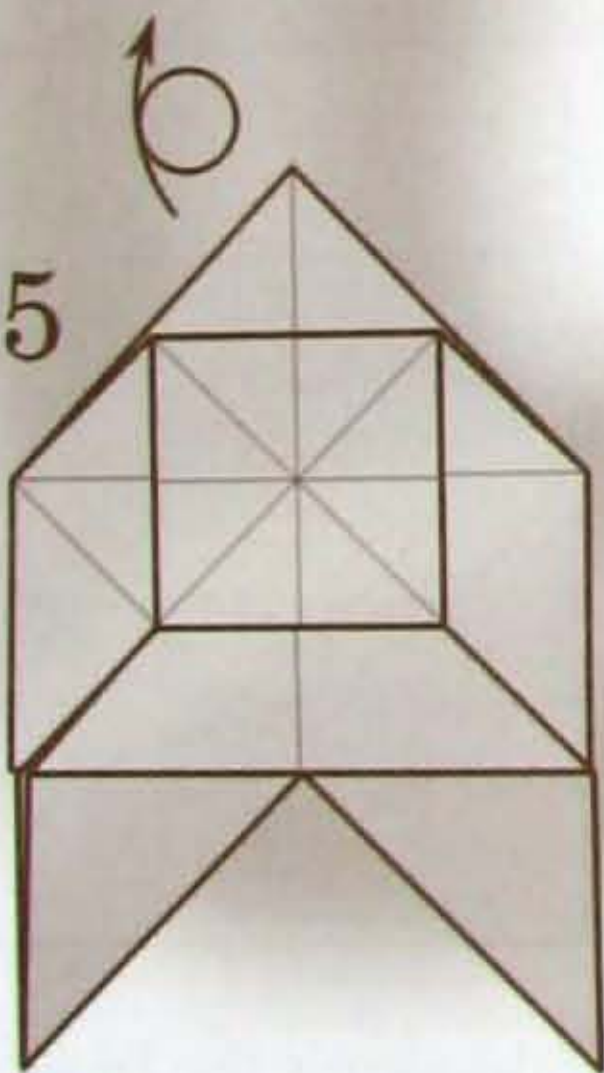

14

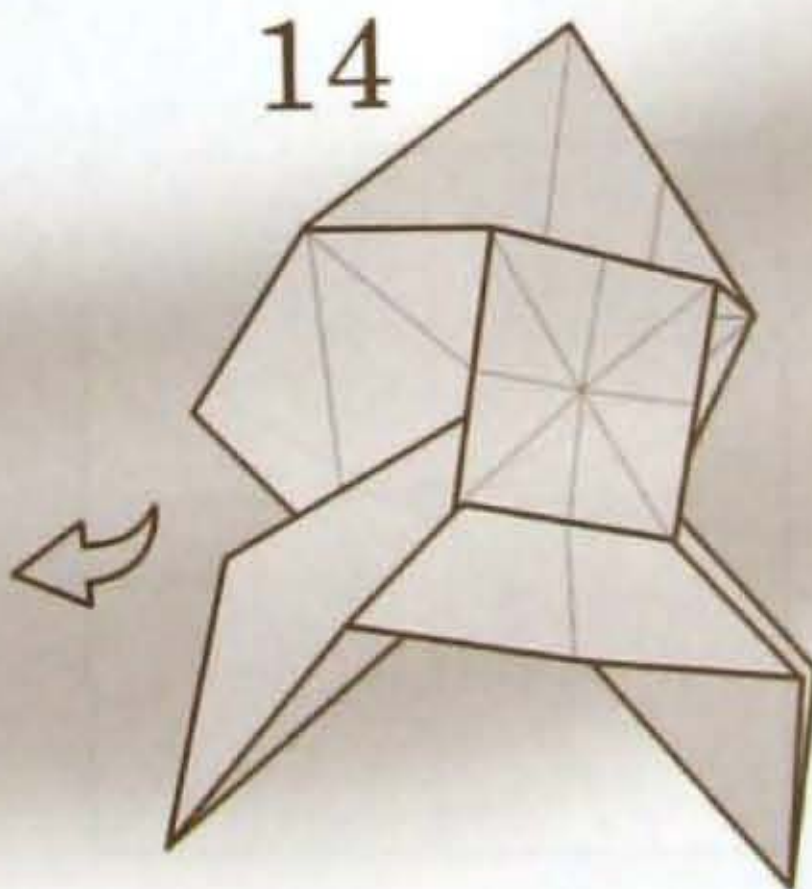

13



28

12

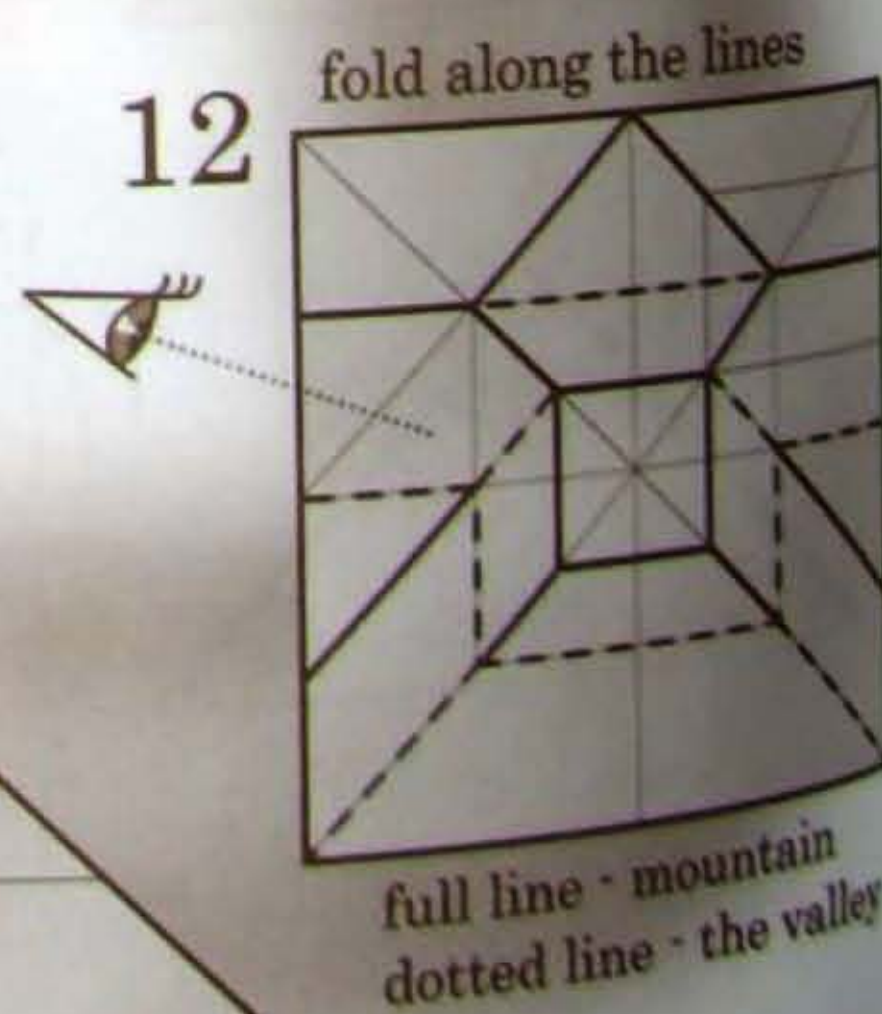

10

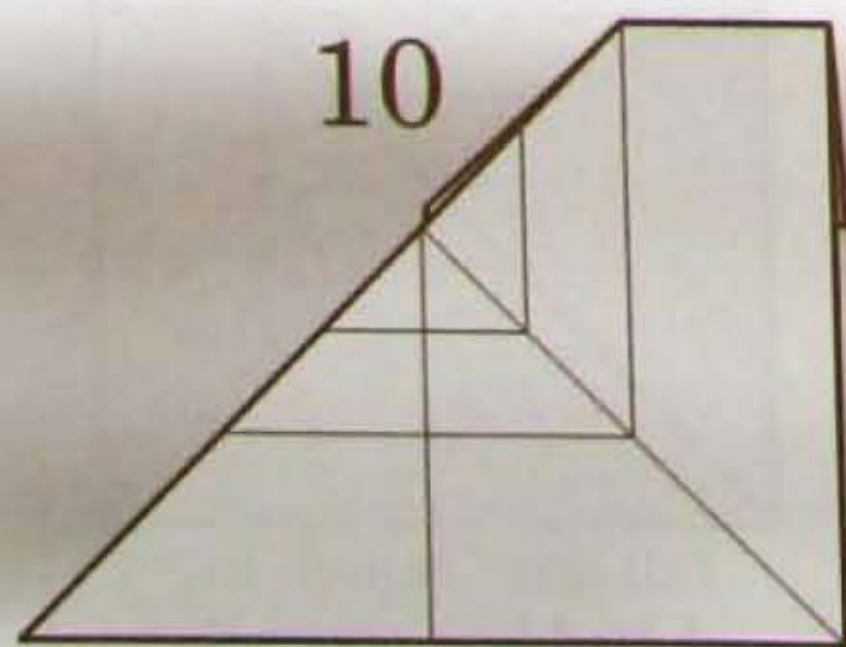

11

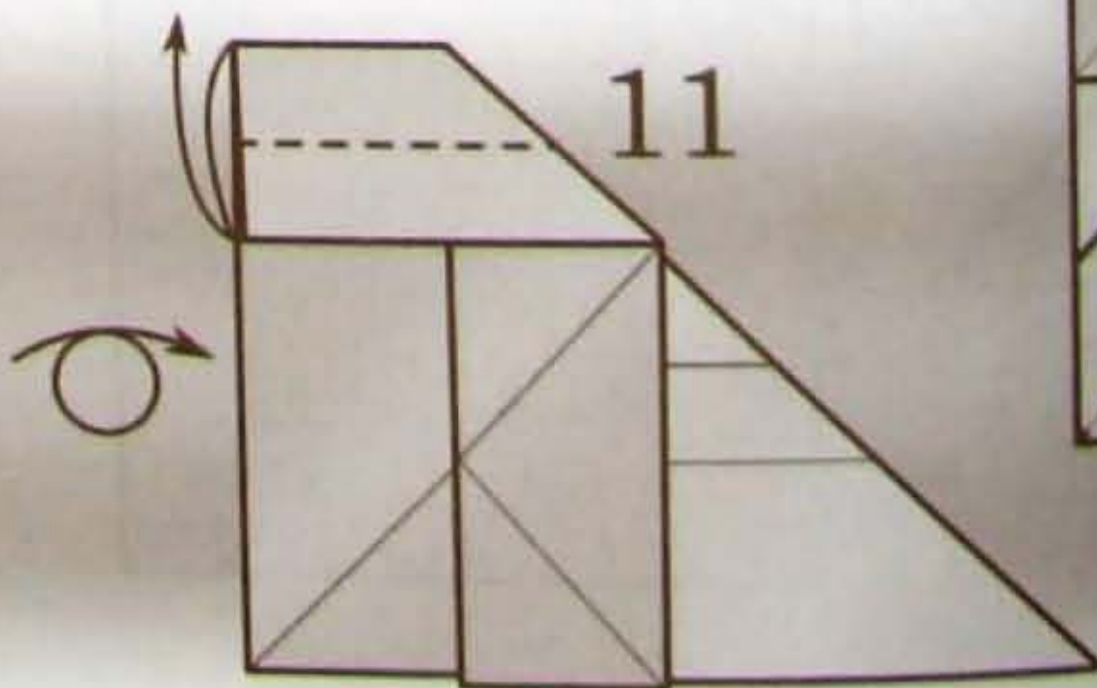

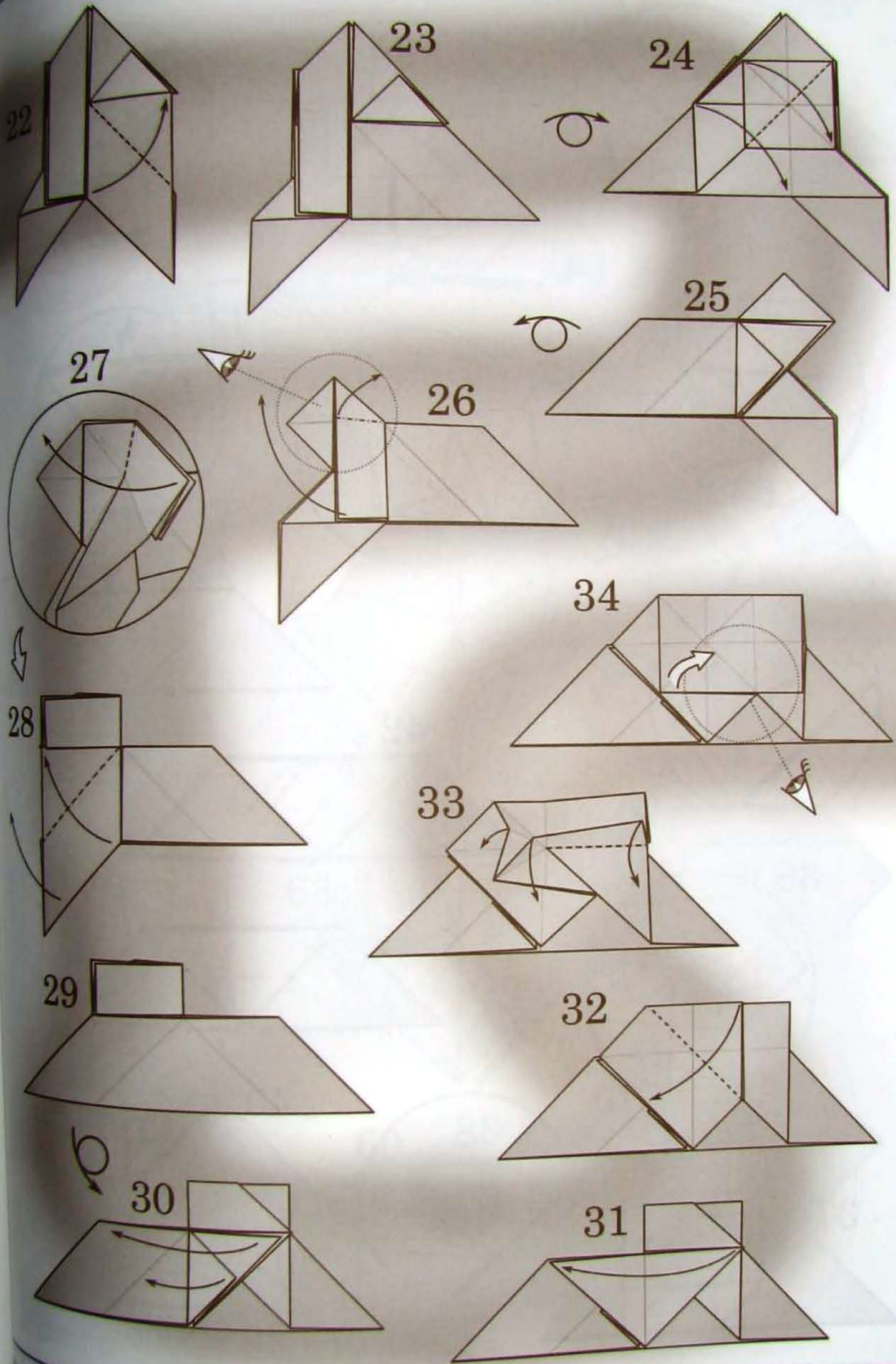

nes

mountain
the valley

17

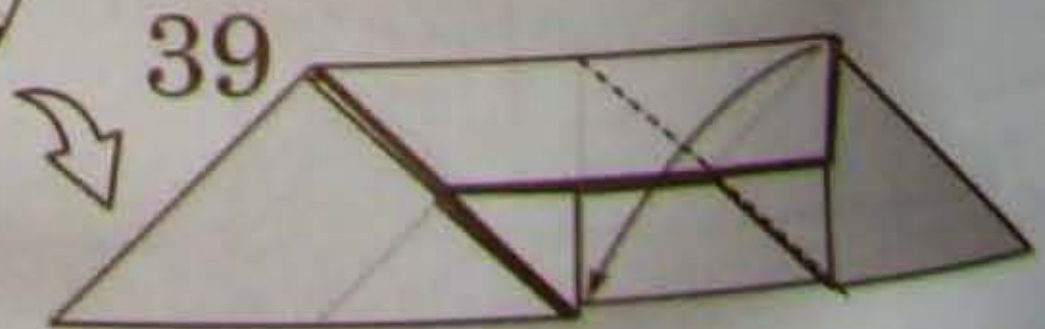
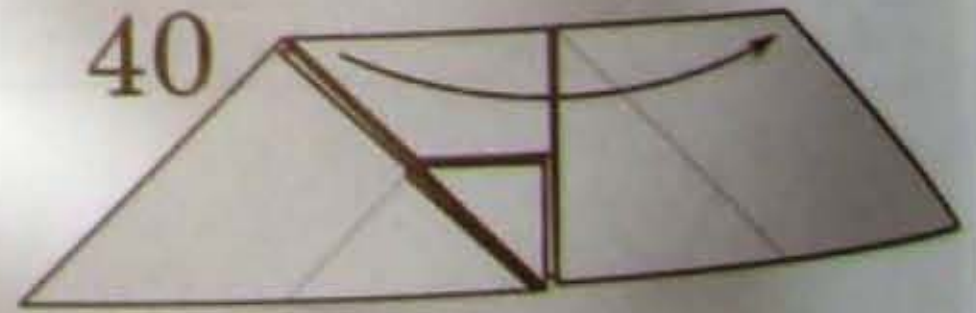
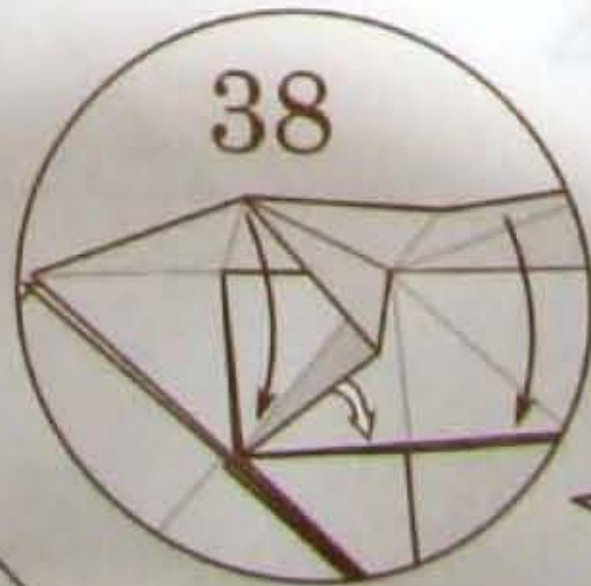
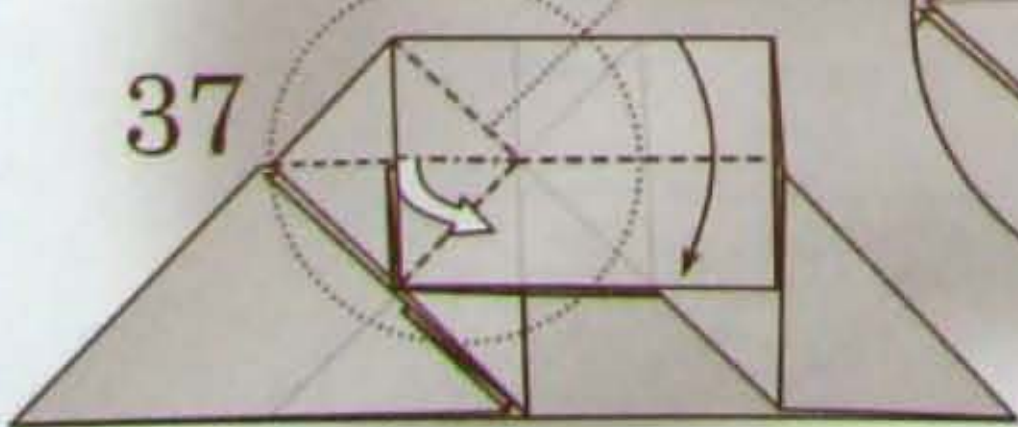
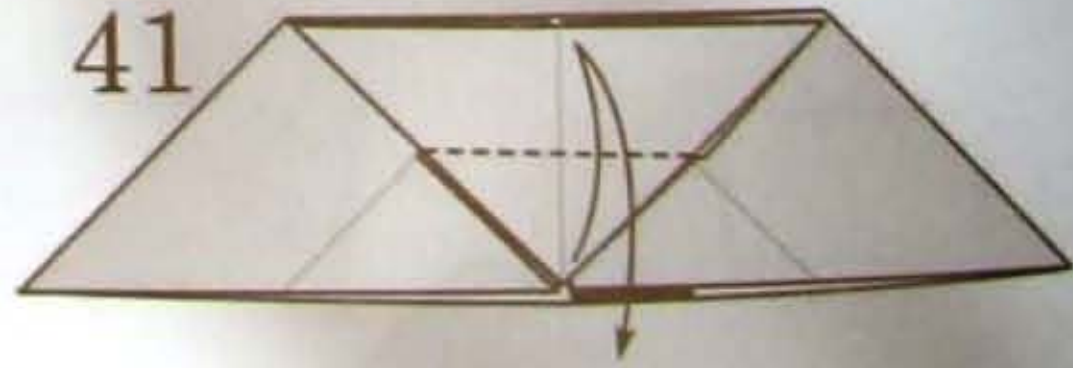
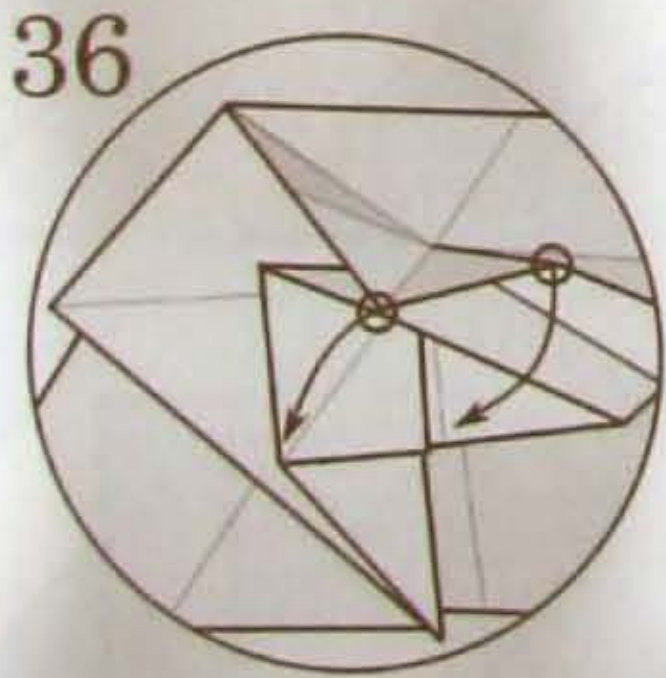
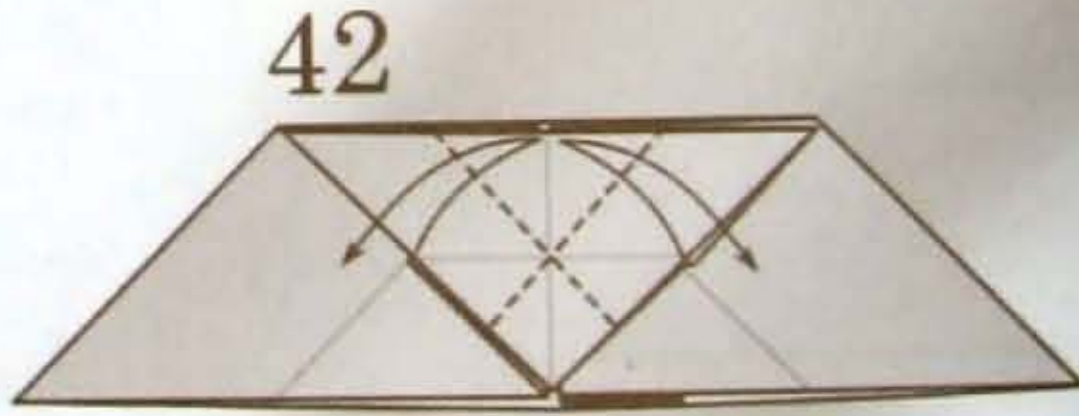
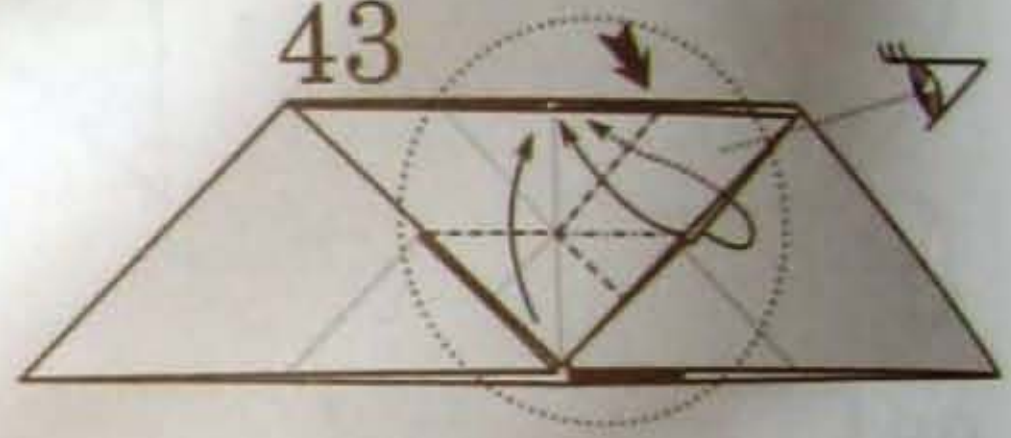
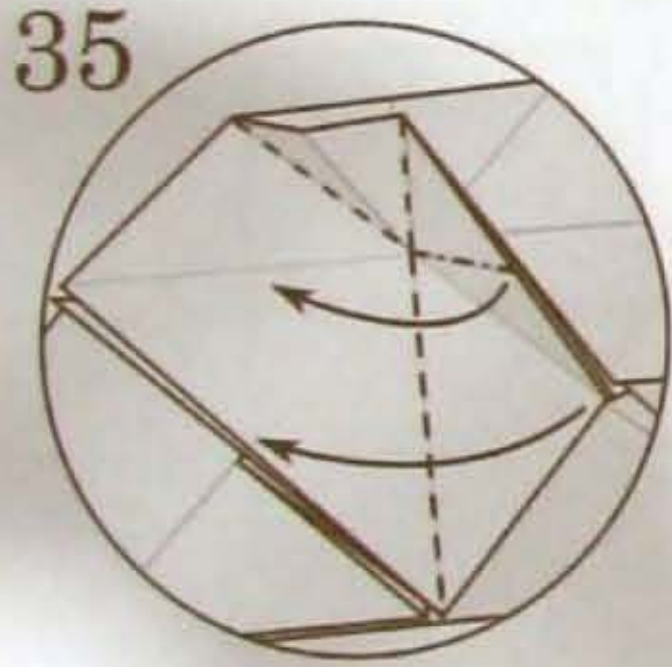
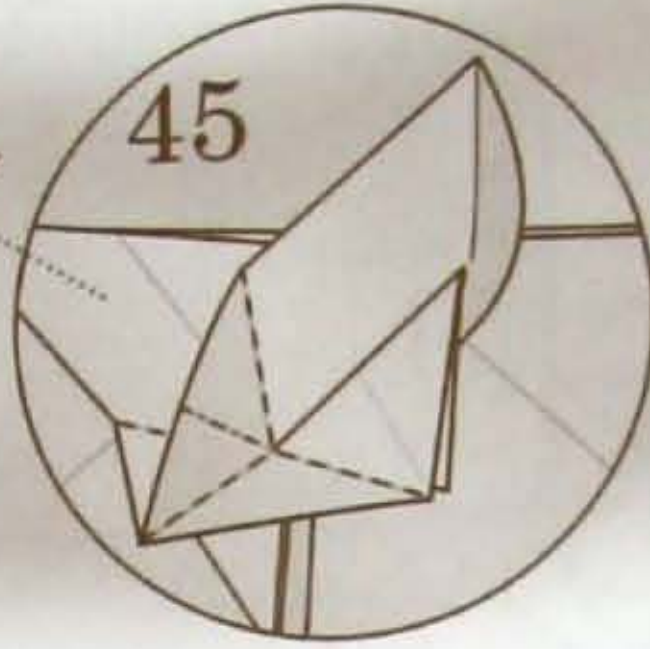
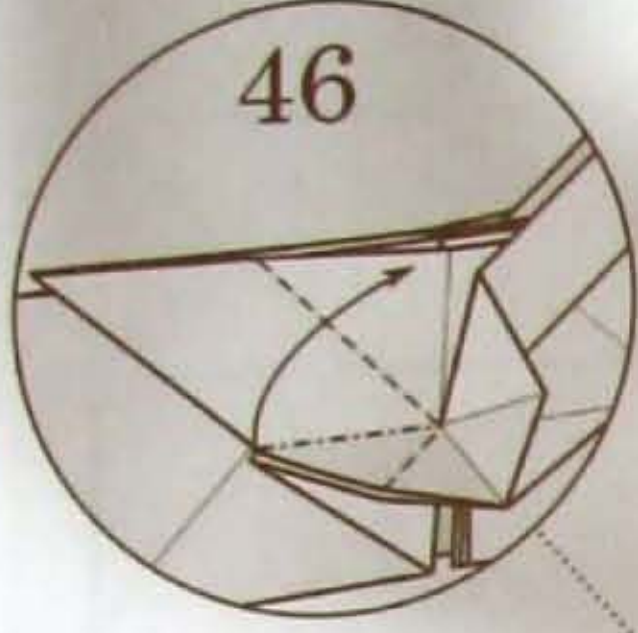
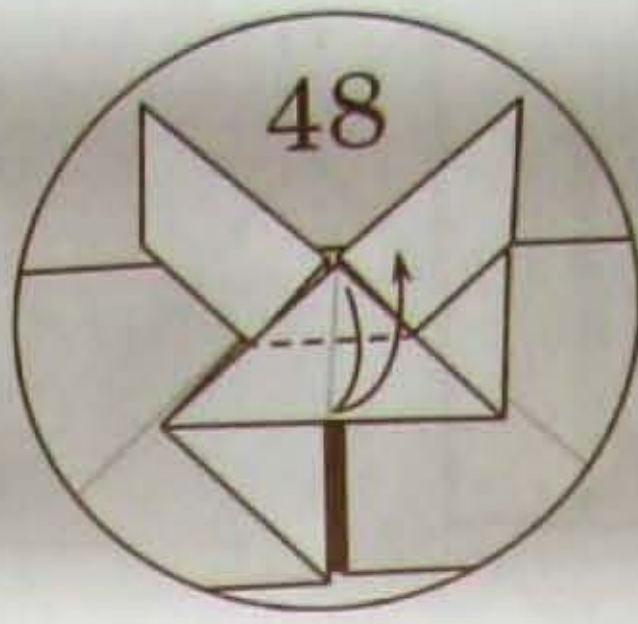

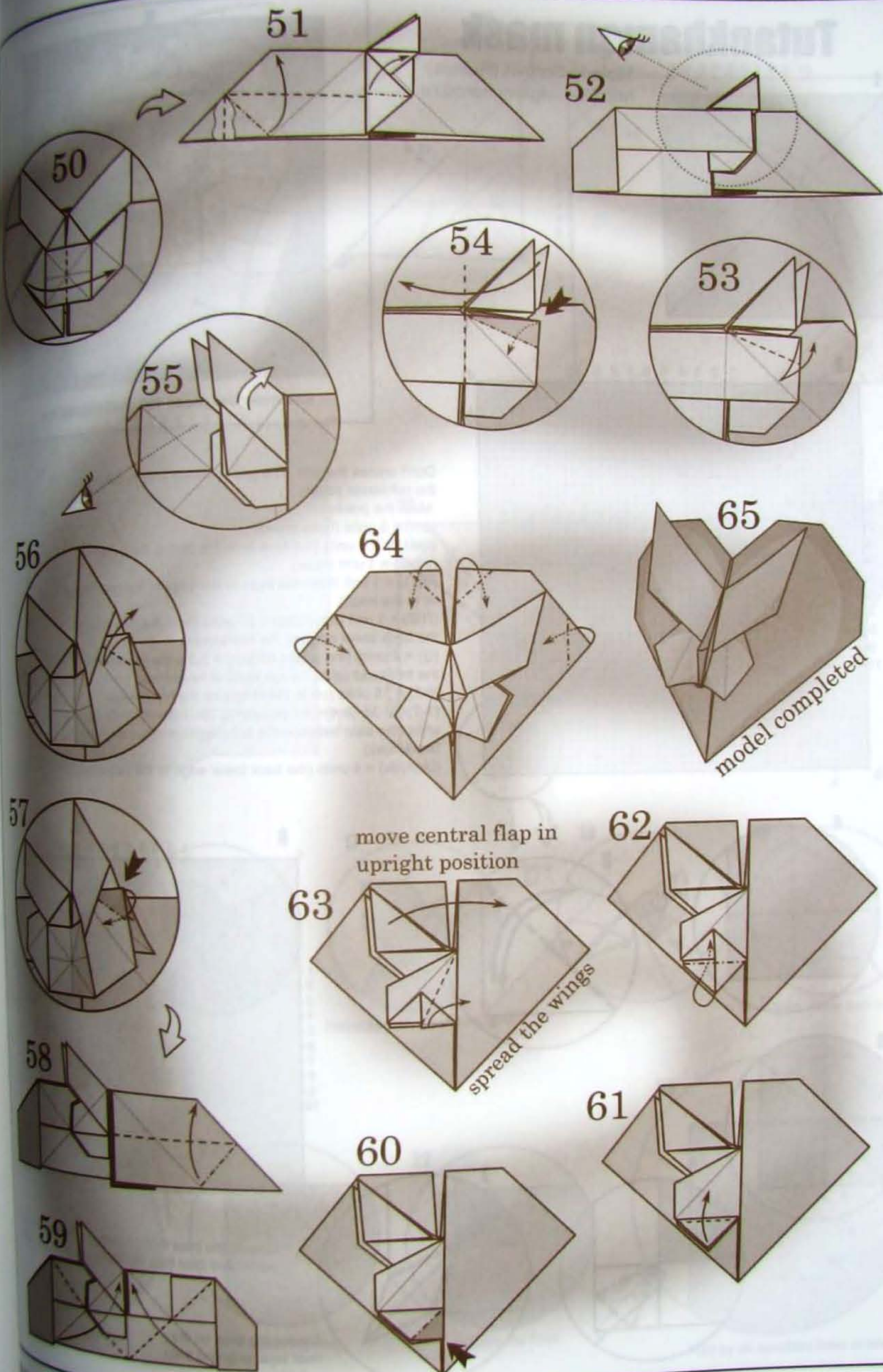

Tutankhamen mask

Victoria Serova (Russia)
<http://vs-origami.narod.ru>



Recommended paper: 120 g/m2 600x600mm

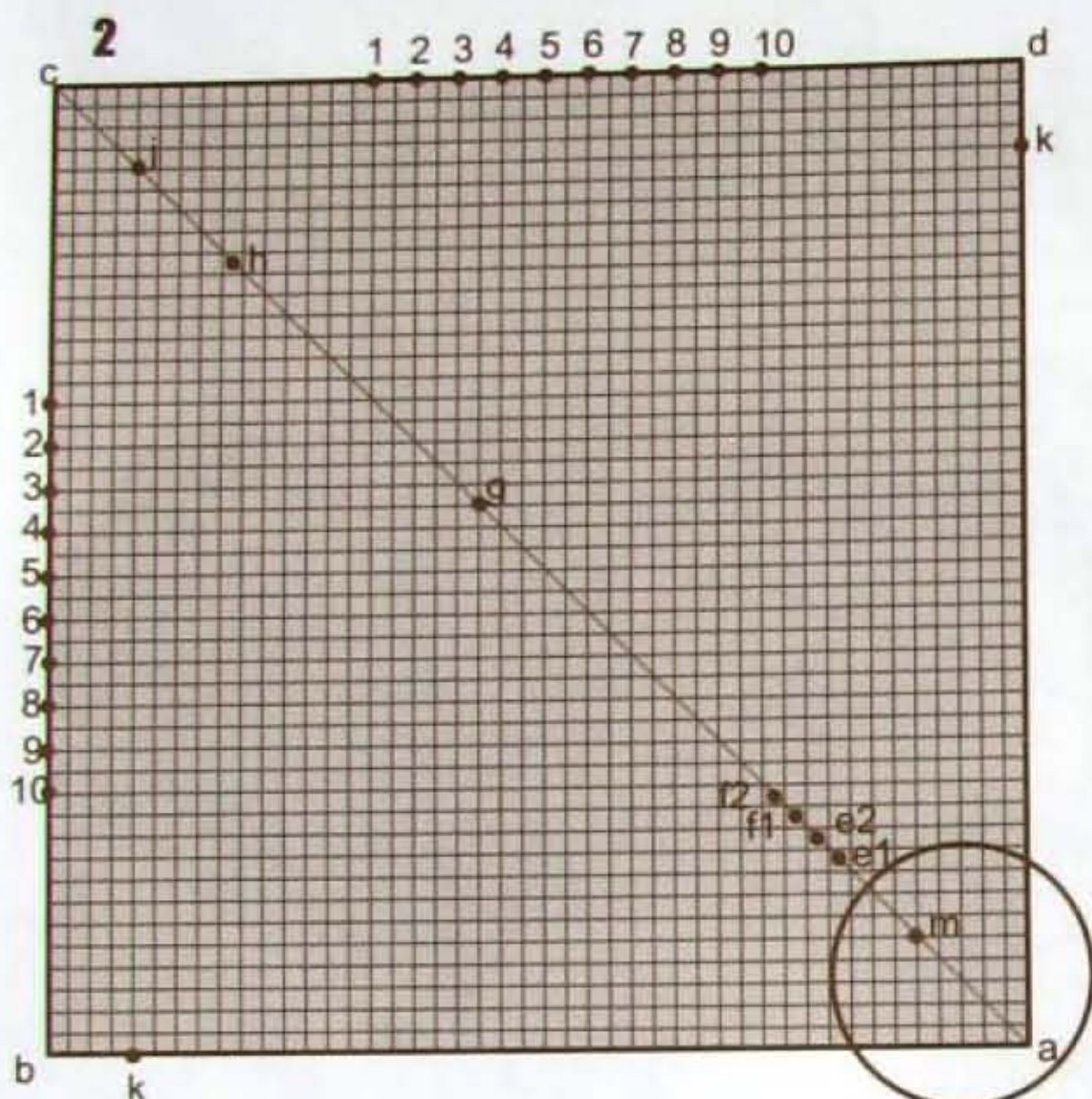
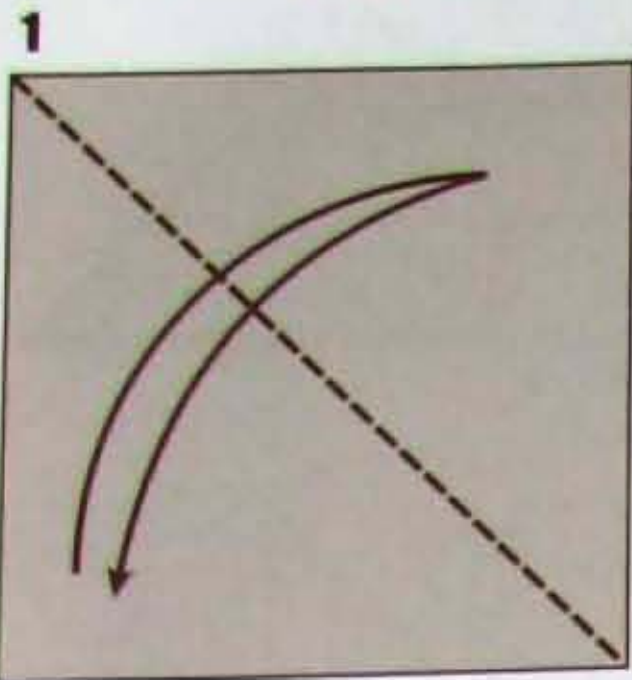

Don't crease the grid. The grid is shown only to describe the reference points.

Mark the points.

(am) = 5 units (false beard)

(me1) = 3,5 units (the face from the chin to the eyes)

(e1e2) = 1 unit (eyes)

(e2f1) = 1 unit (from the eyes to the edge of the headdress or to the hoop)

(f1f2) = 1 unit (hoop)(ag) = 25 units (from the beard tip to the back lower edge of the headdress)

(cj) = 4 units (the snake tail)(ch) = 8,5 units (the height of the forehead up to the top bend of headdress)

(c-1) = 15 units (up to the steps on the headdress)

(1-2)=(2-3)=(3-4)=(4-5)=(5-6)=(6-7)=(7-8)=(8-9)=(9-10) = 2 units (the step between the two neighbor strips on the headdress)

(bk)=(dk) = 4 units (the back lower edge of the headdress)

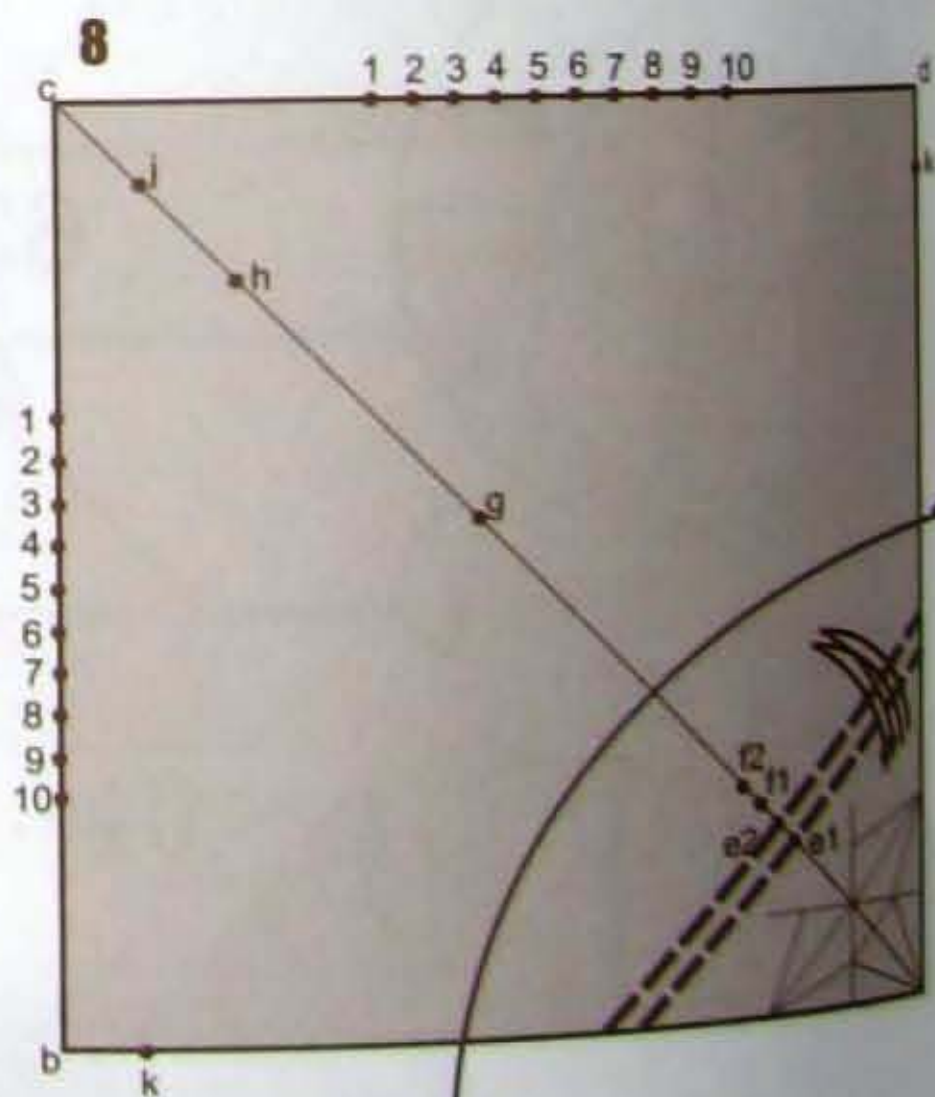
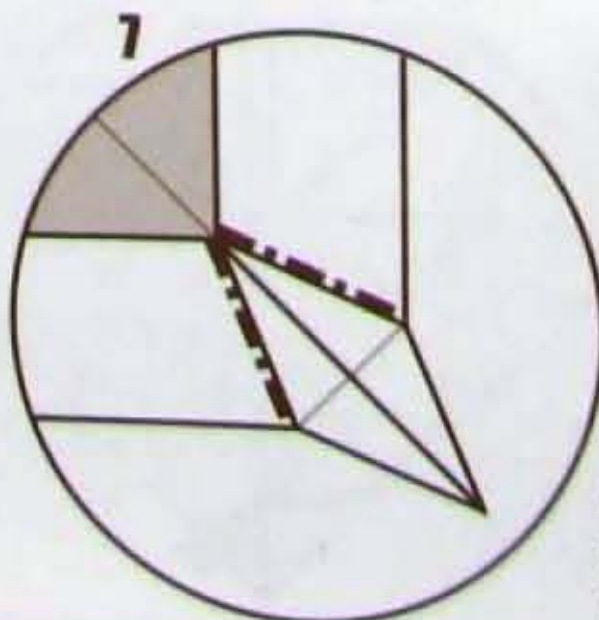
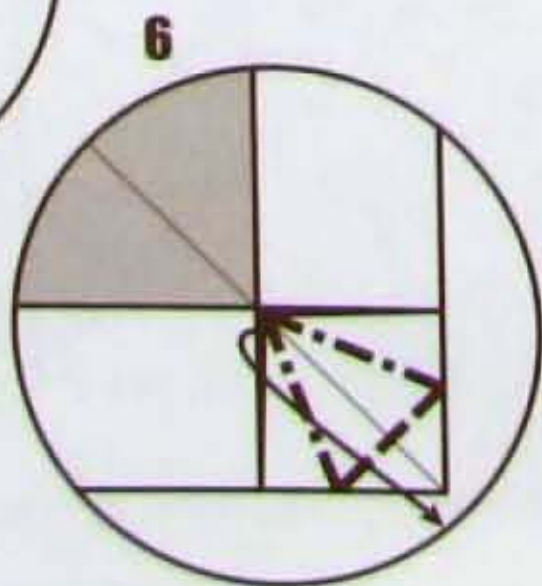
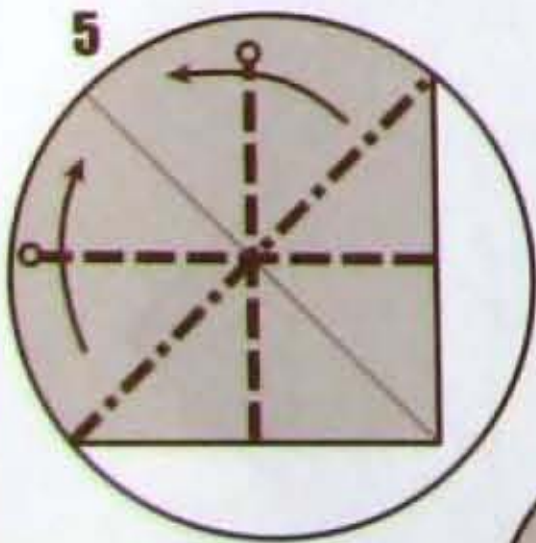
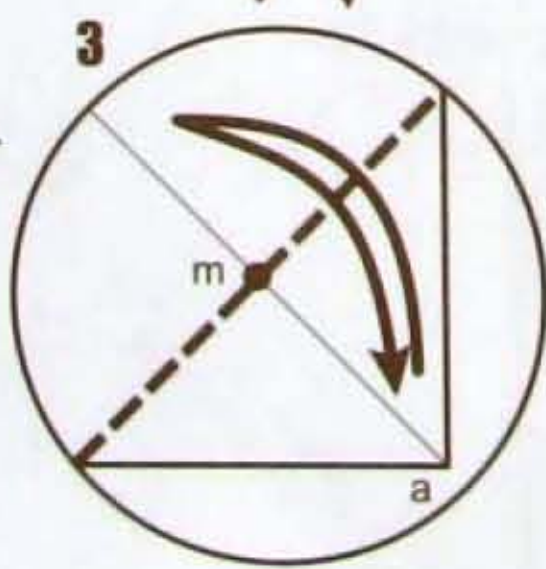
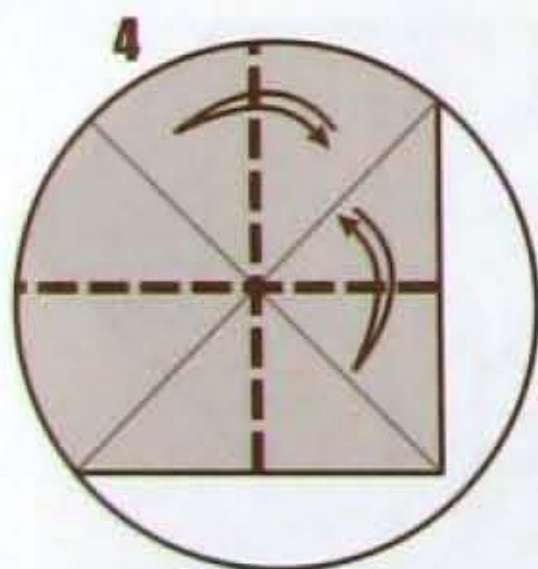

Crease the lines that go through the (e1) and (e2) points and then turn the figure on the other side

Crease the lines on the near layer only and then unfold to square

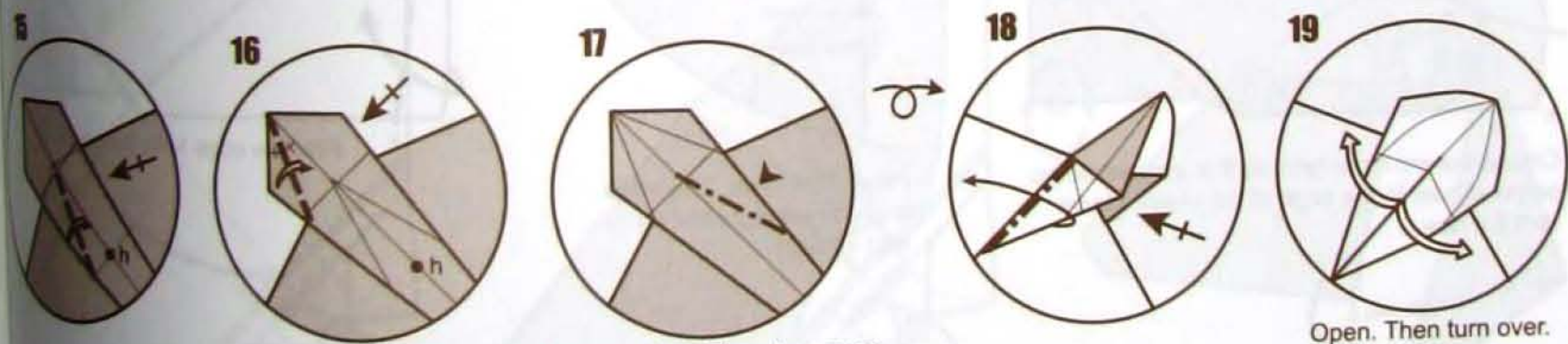
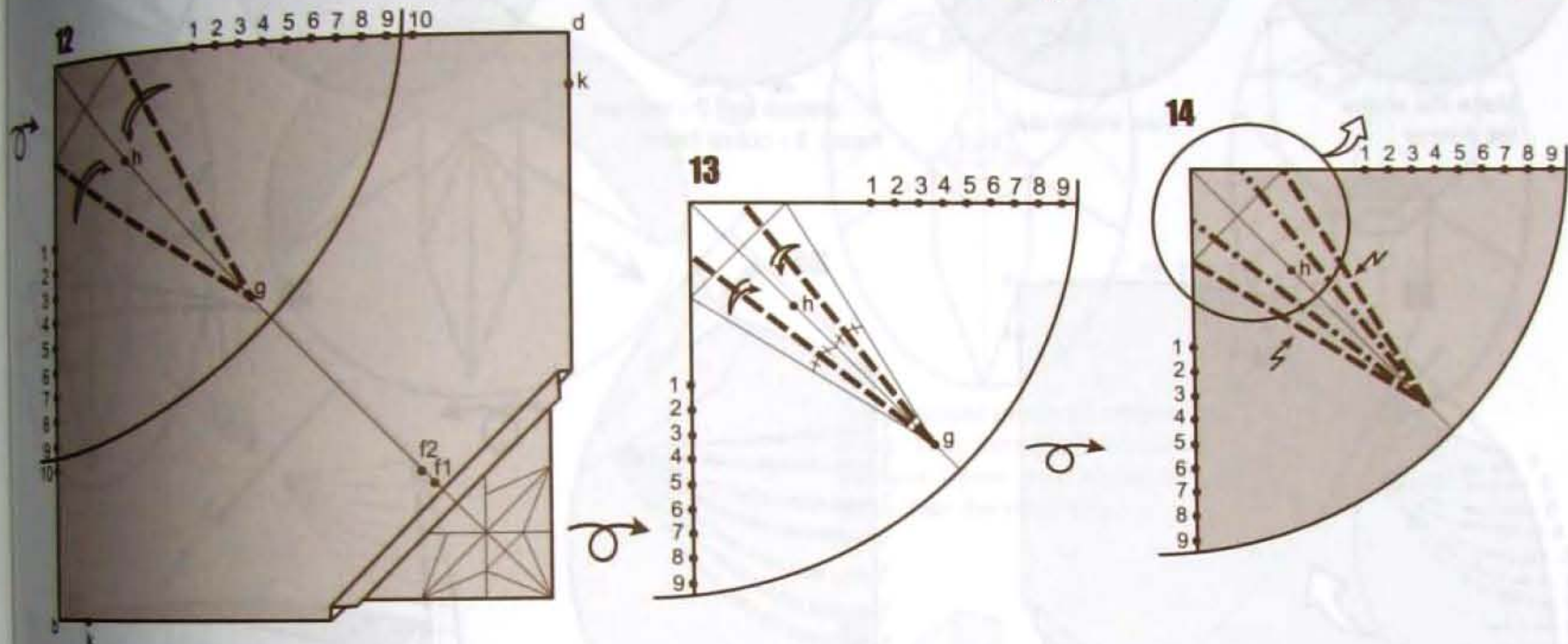
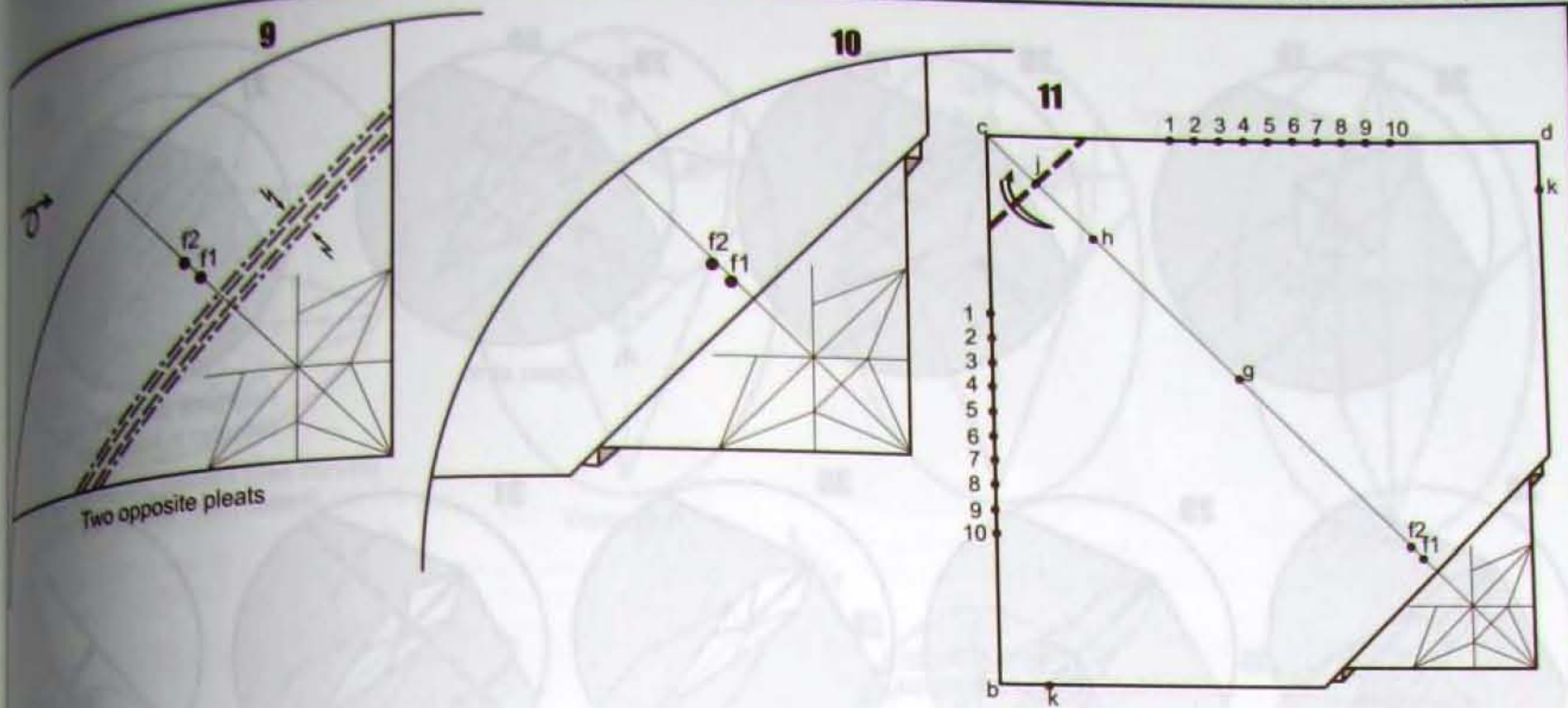

Reverse fold. Then turn over.

Open. Then turn over.

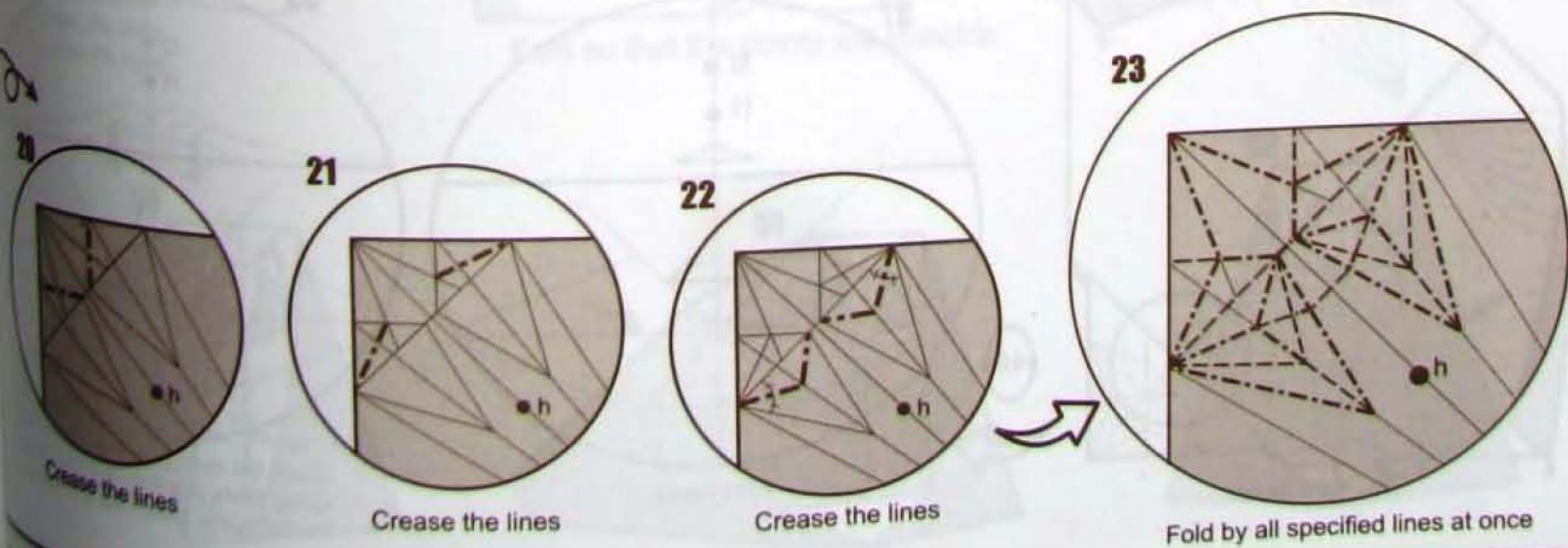

Crease the lines

Crease the lines

Crease the lines

Fold by all specified lines at once

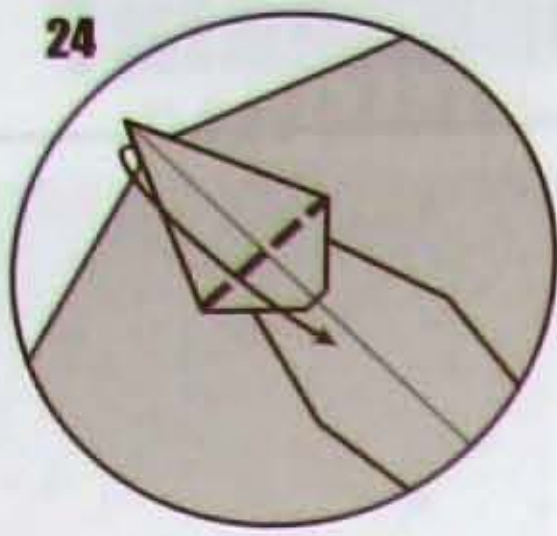

24

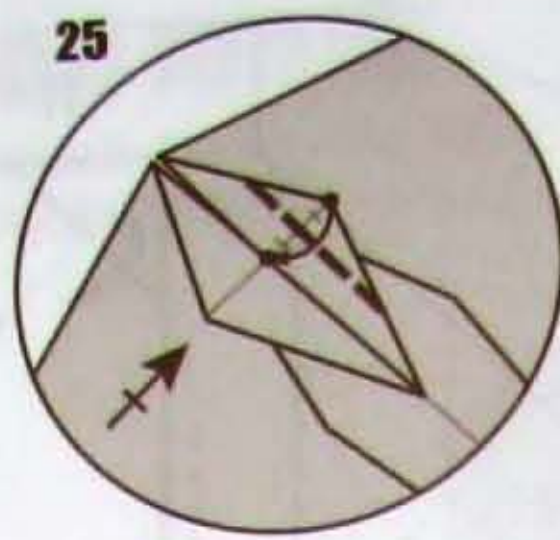

25



26

Open sink

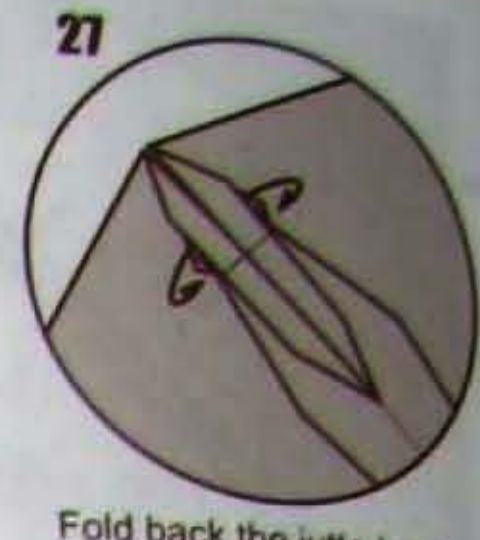

27

Fold back the juttied out triangles to hide them



28

Make the snake tail thinner

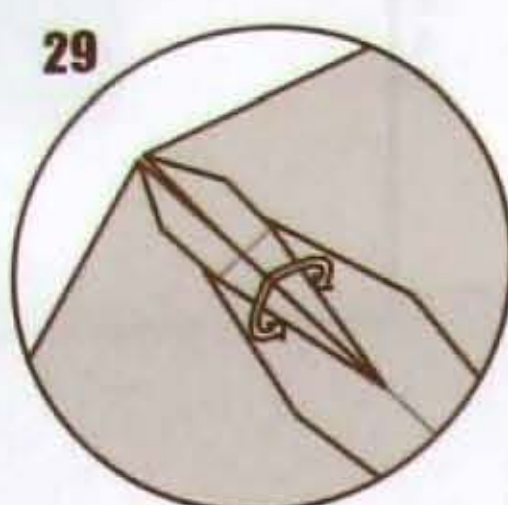

29

Turn inside out

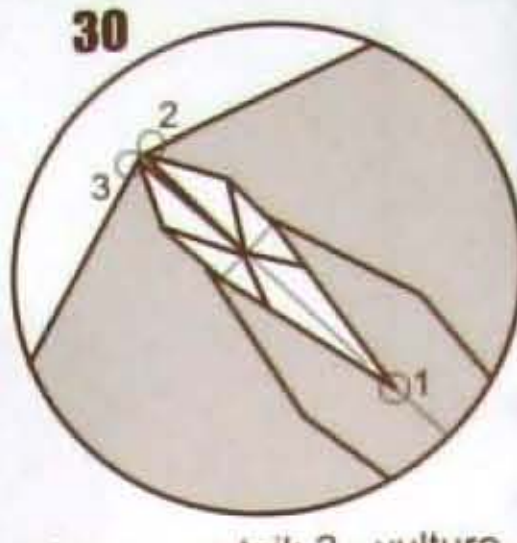

30

1 - uraeus tail; 2 - vulture head; 3 - cobra head

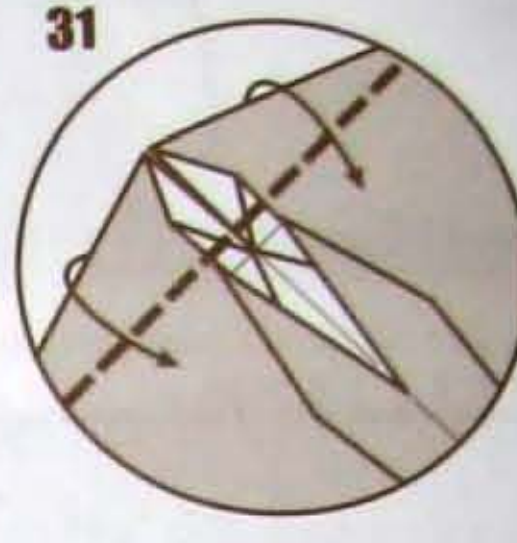

31

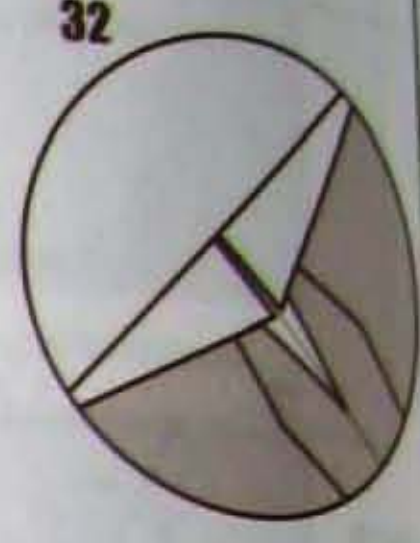

32

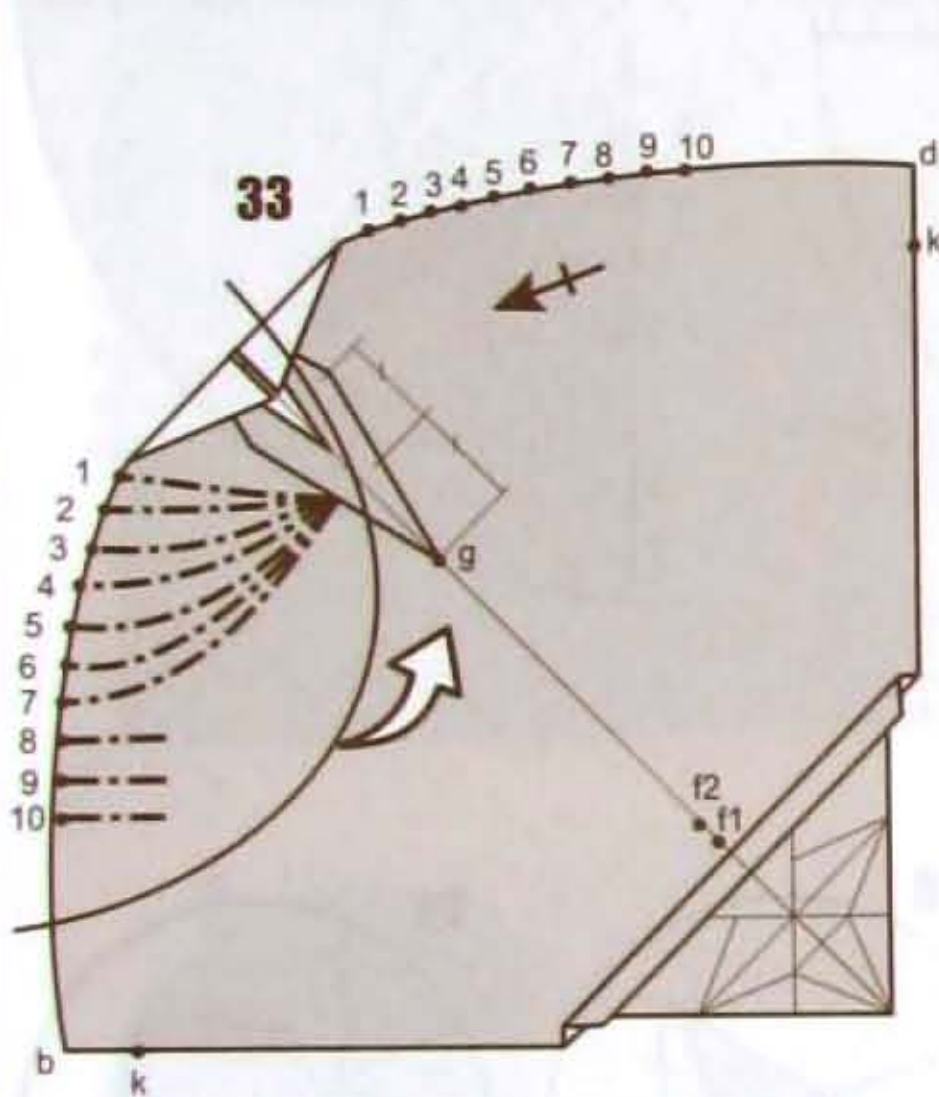

33

Crease the arc mountains so that they would go perpendicular to the edge of the sheet. Model isn't flat now.

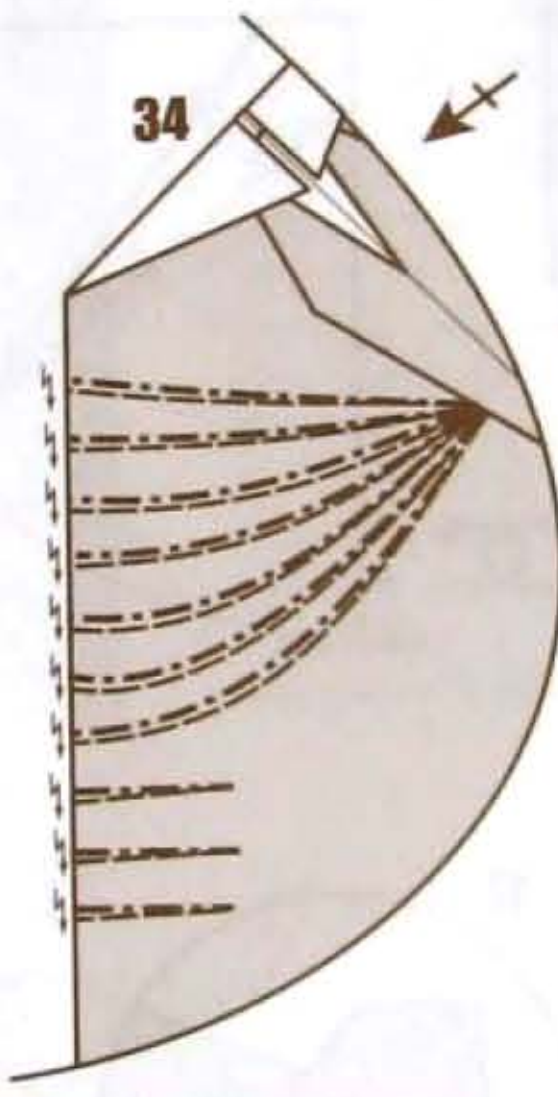

34

Pleat. Turn over. The edge is shown straight but really isn't straight

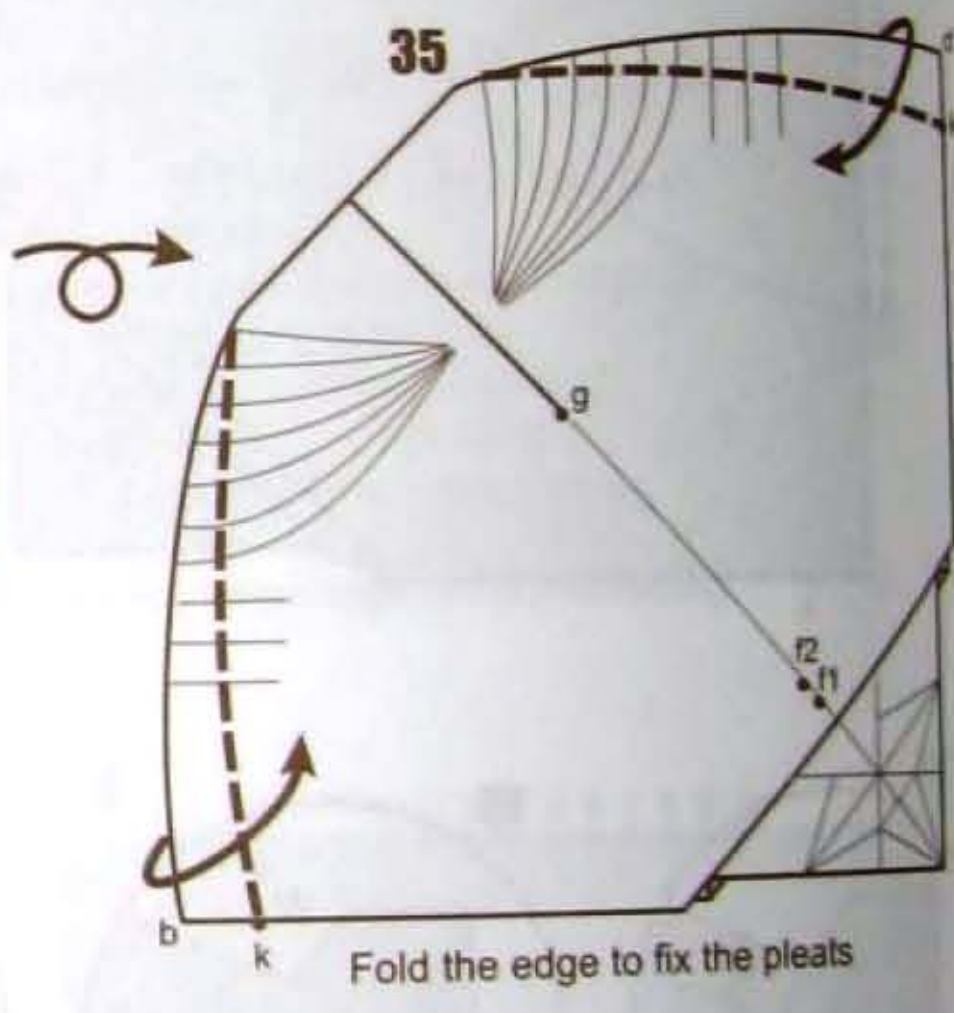

35

Fold the edge to fix the pleats

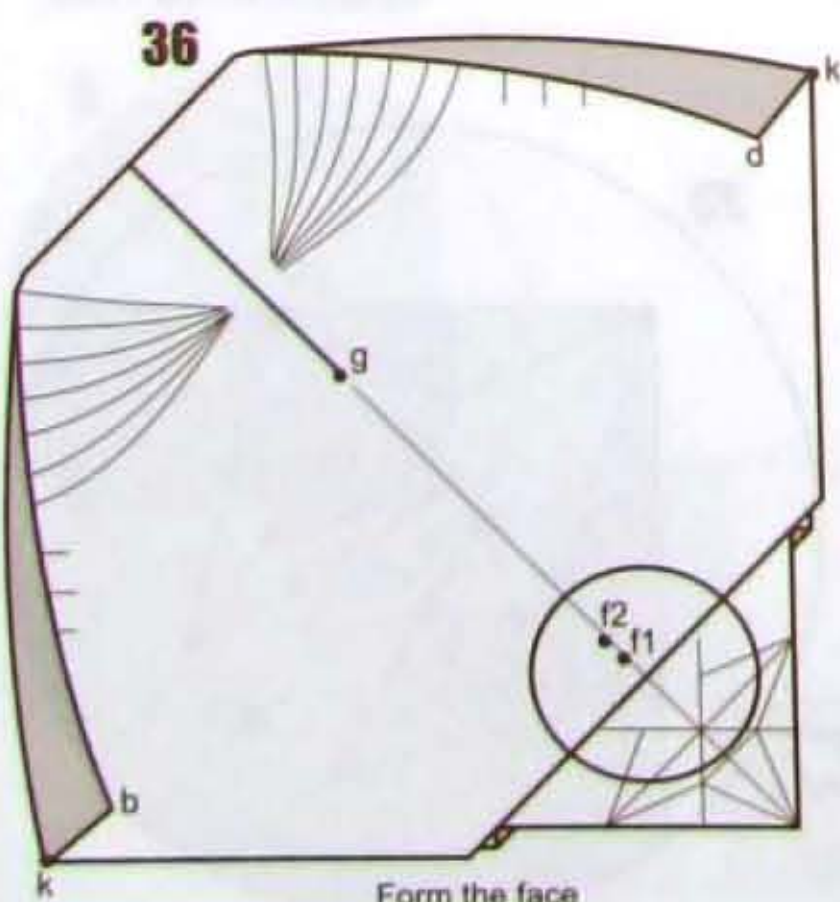

36

Form the face

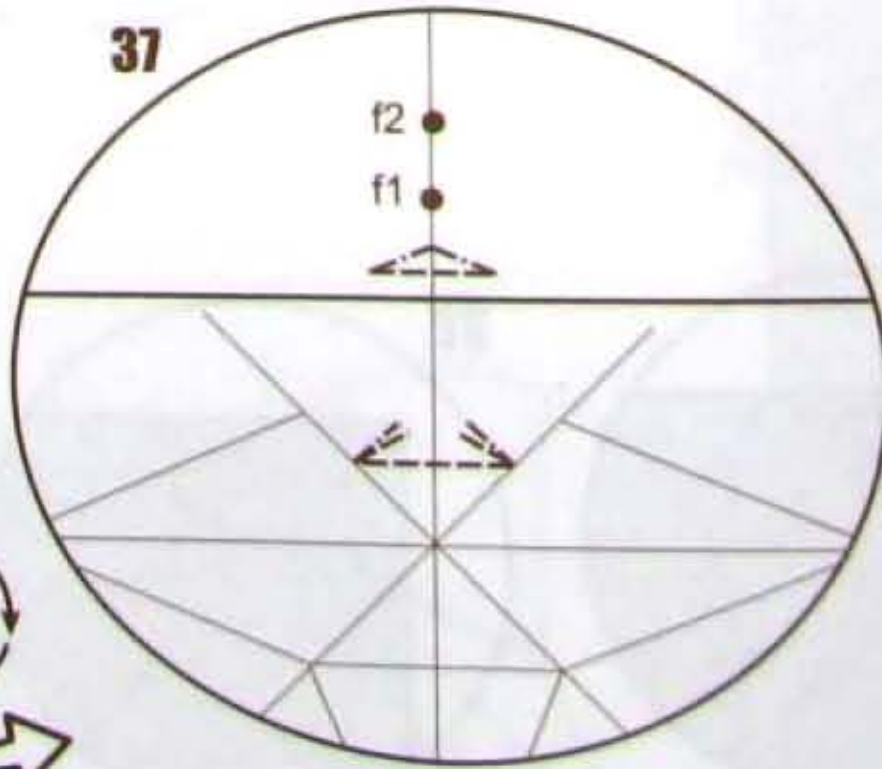

37

Fold hardly

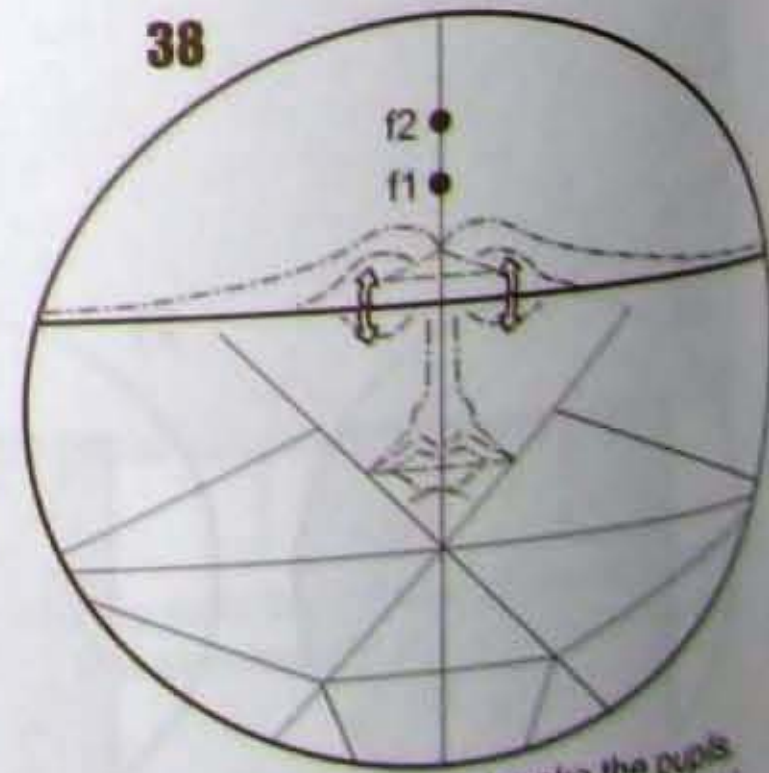

38

Open the eyes and make the pupils. Other folds that form the face should be soft. Only base folds are shown.

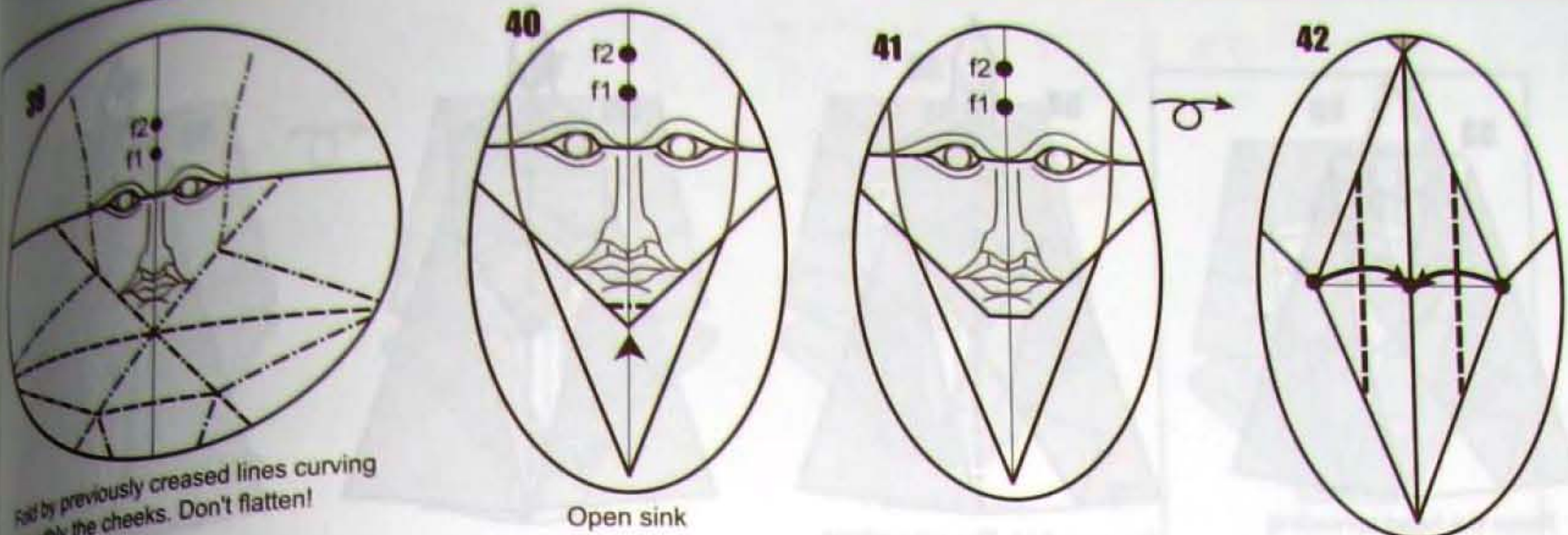

Fold by previously creased lines curving smoothly the cheeks. Don't flatten!

Open sink

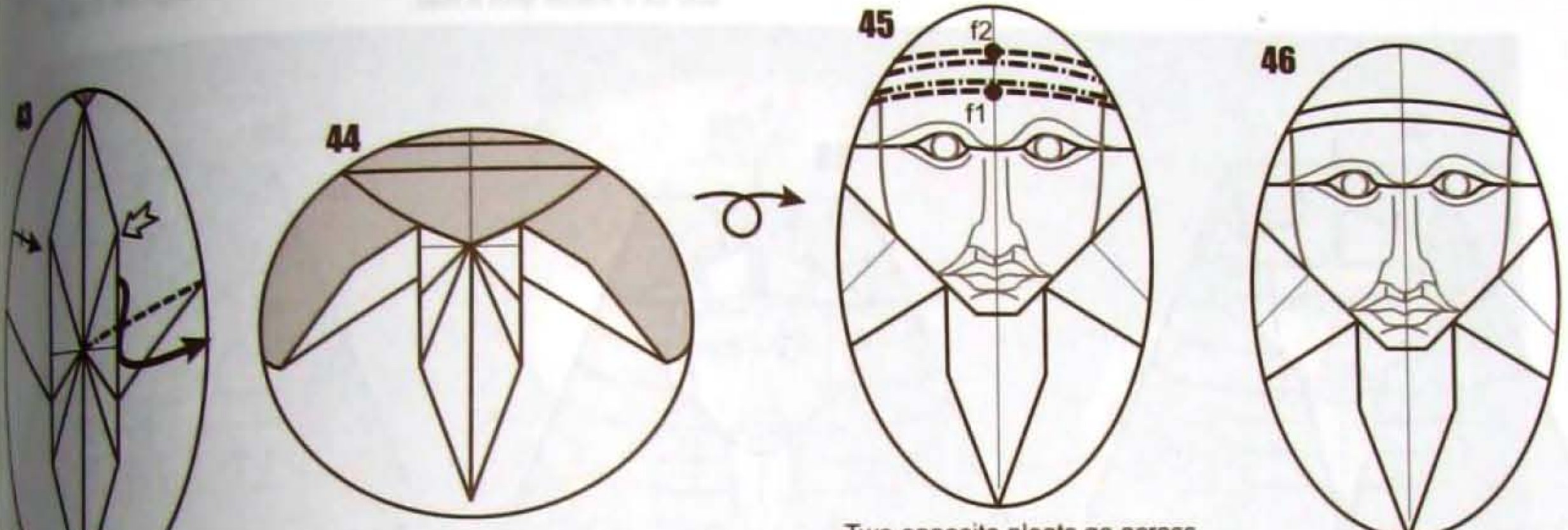

Two opposite pleats go across sheet. They form the hoop above the face. Upper pleat should be wider than the lower one.

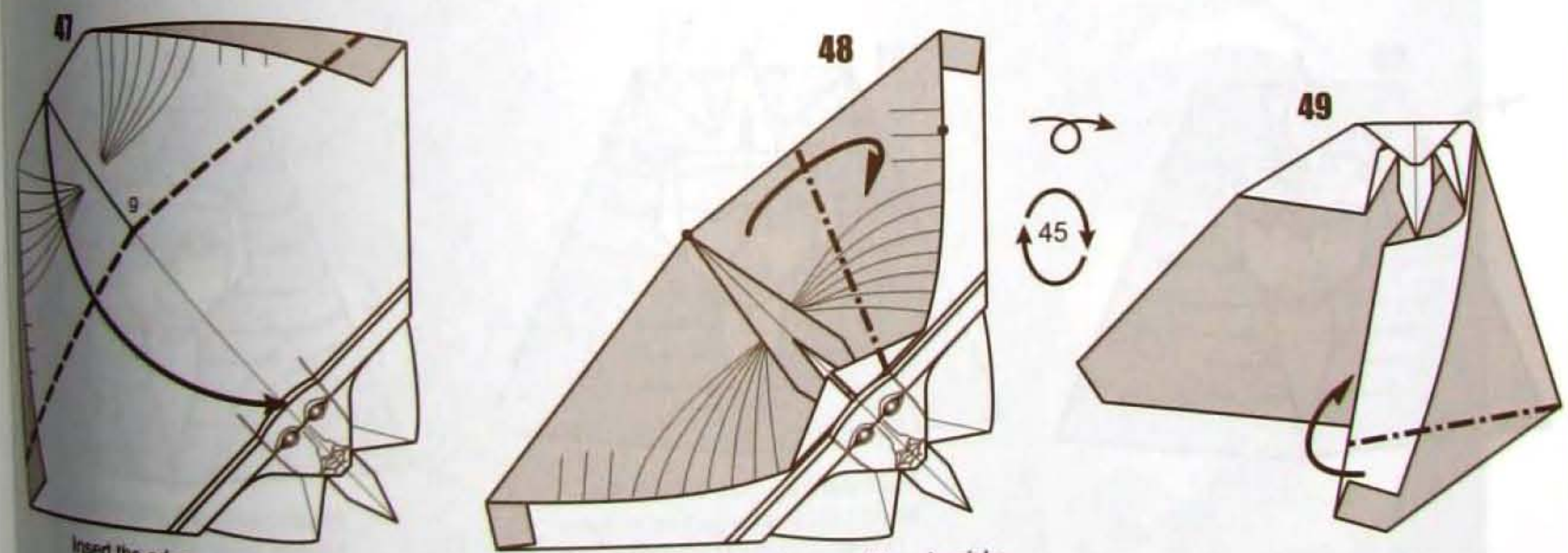

Insert the edge under the hoop.

Fold so that the points will coincide

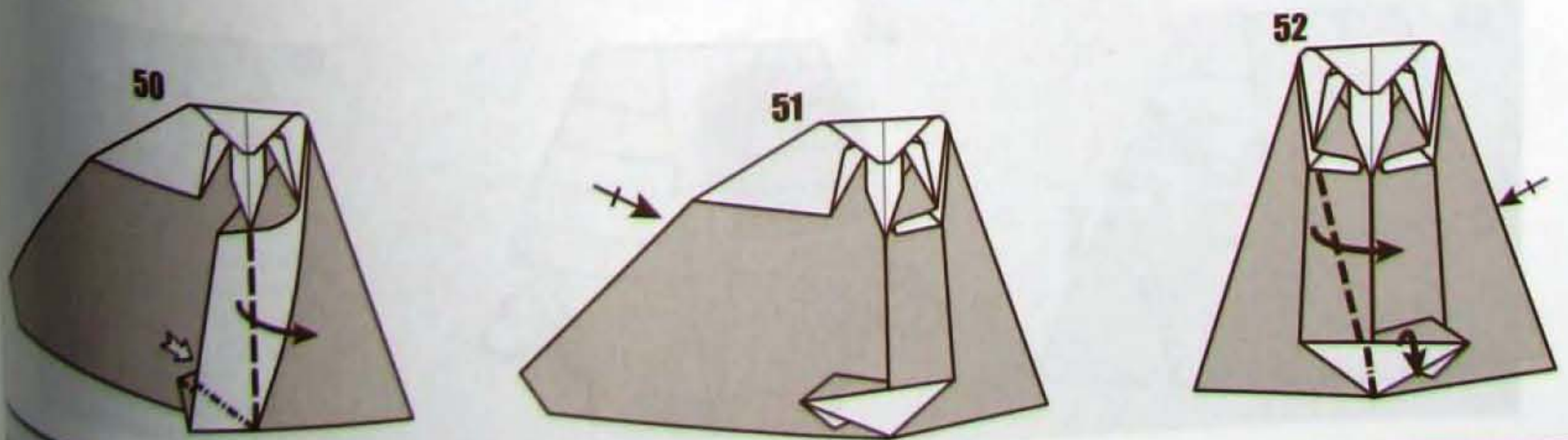

the pupils. The face should be shown.

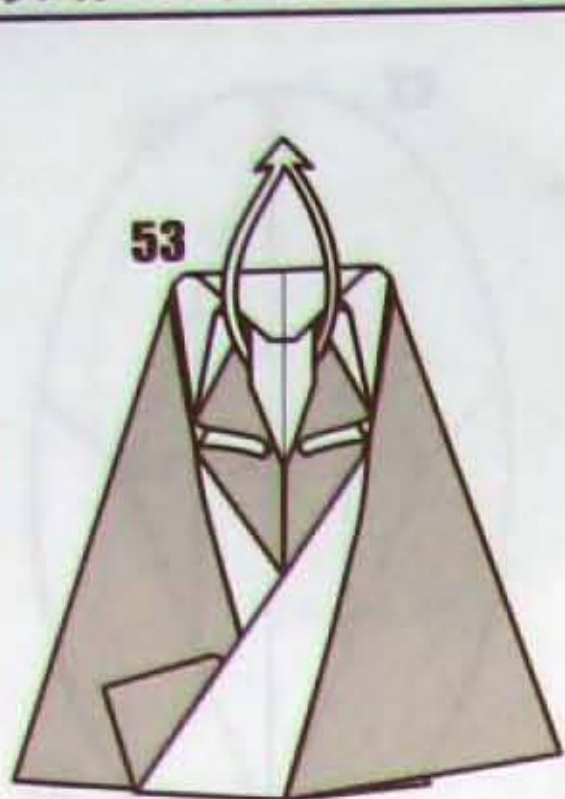

53 Raise the head spreading folds along the axis

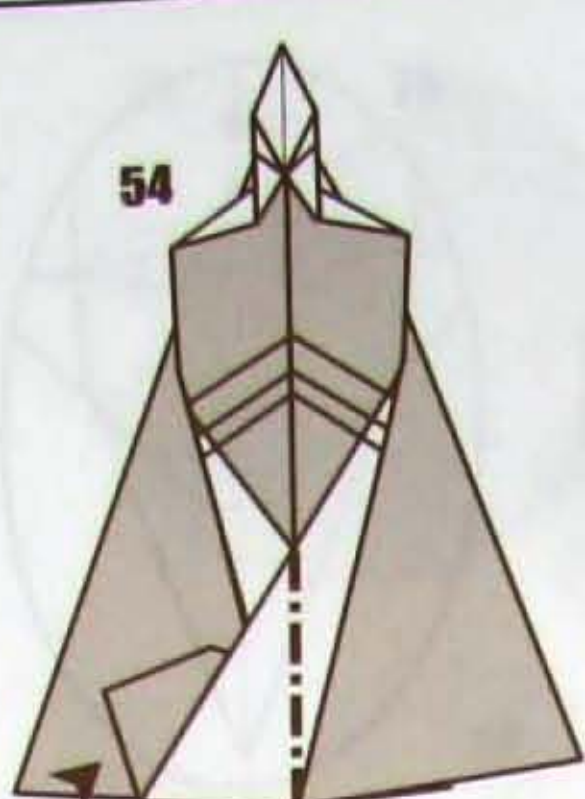

54 Reverse fold. The new edges should go along the axis.

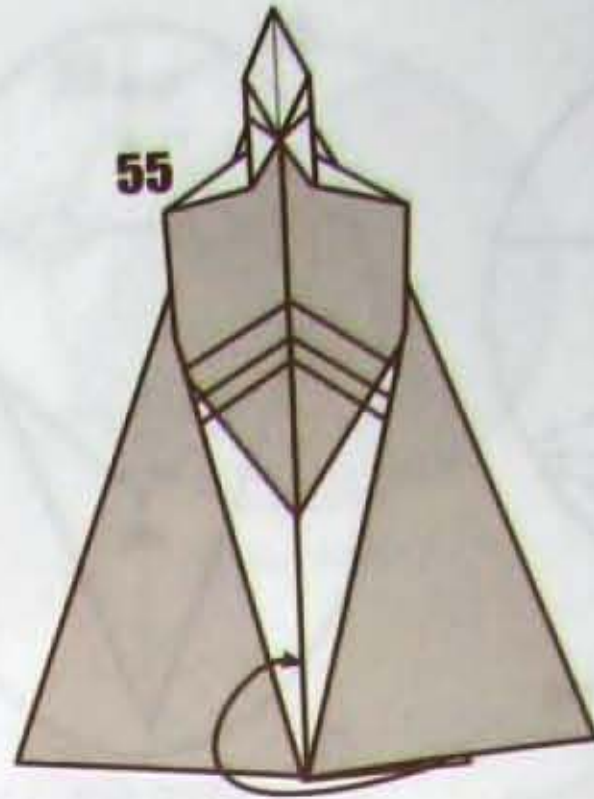

55 Insert the lower flap into the pocket and fix it inside with a fold.



56 Lower the head by folding through the (h) point



57 Pull out the layers



58 Fold downward

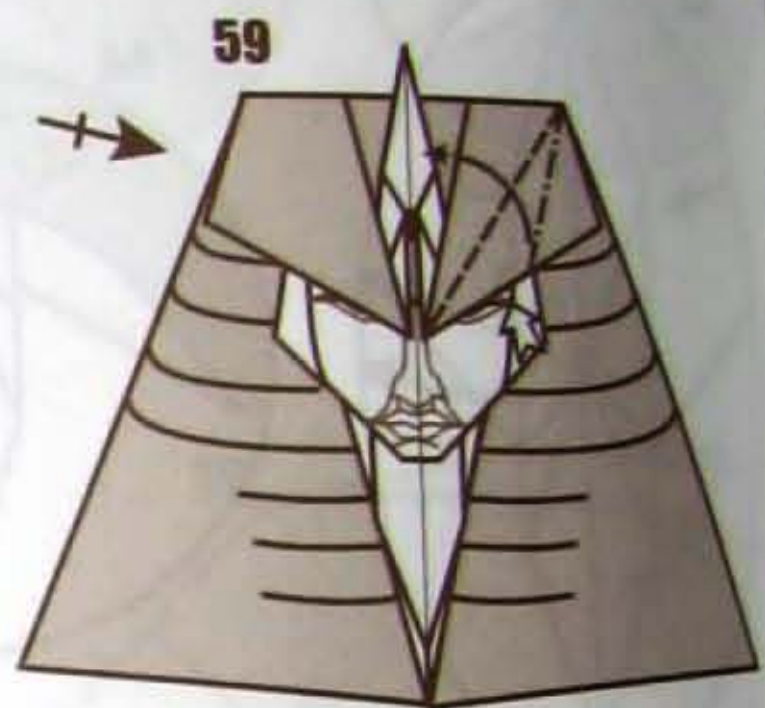

59 Squash fold. Edge insert into the pocket

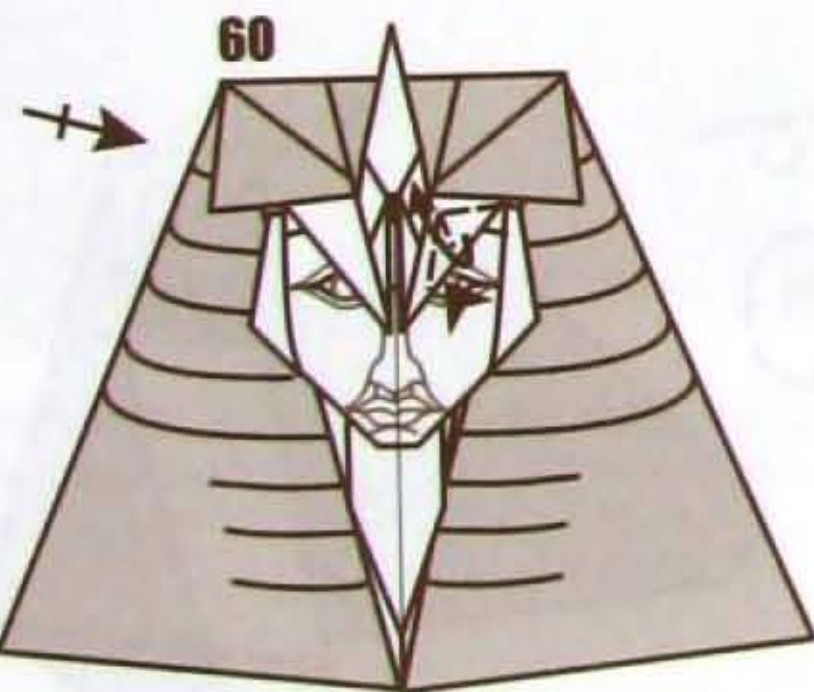

60



61 Tuck the triangles behind the head. Use the three flap to form (1) uraeus tail, (2) vulture head and (3) cobra head



62 Pleat to form the shoulders and the Nemes lower edge

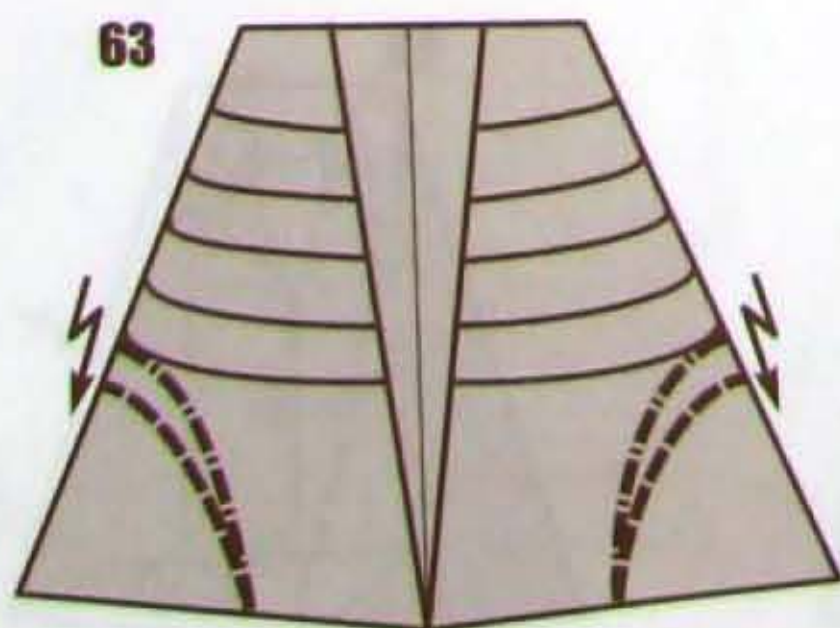

63

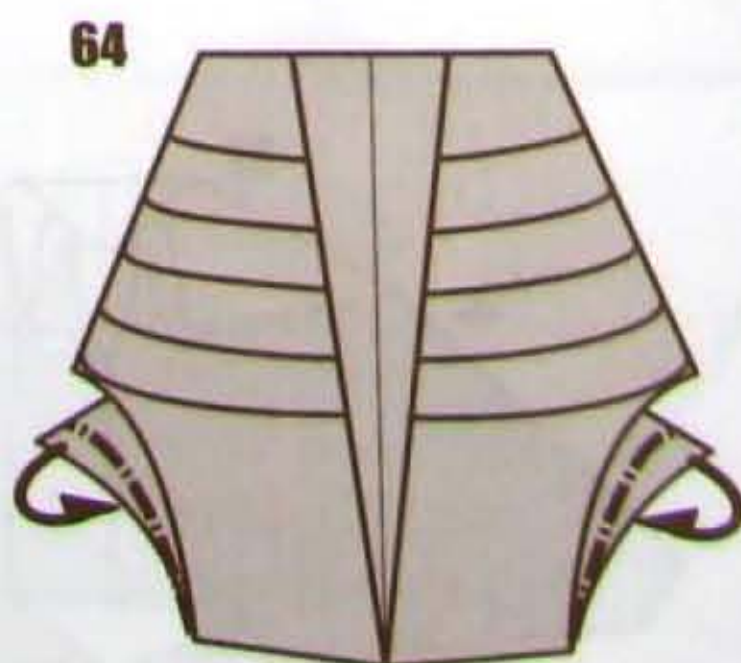

64

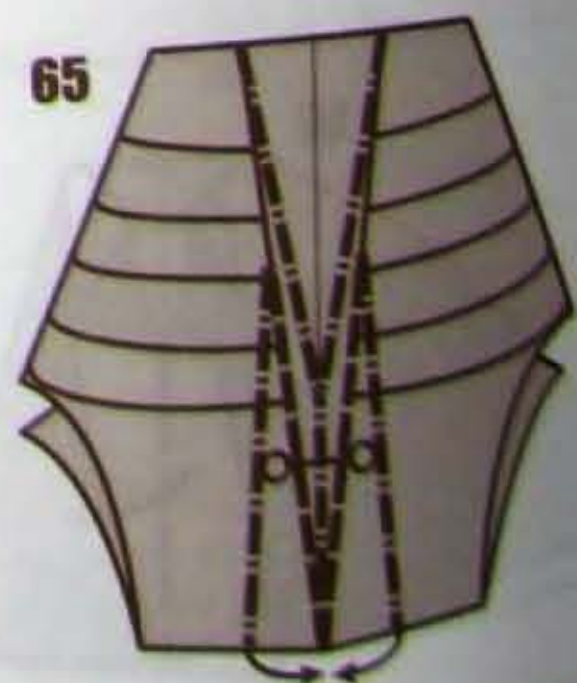

65



Виктория Серова

Victoria Serova



Mask of Tutankhamen

Маска Тутанхамона

BLUE BAR PIGEON

Román Díaz

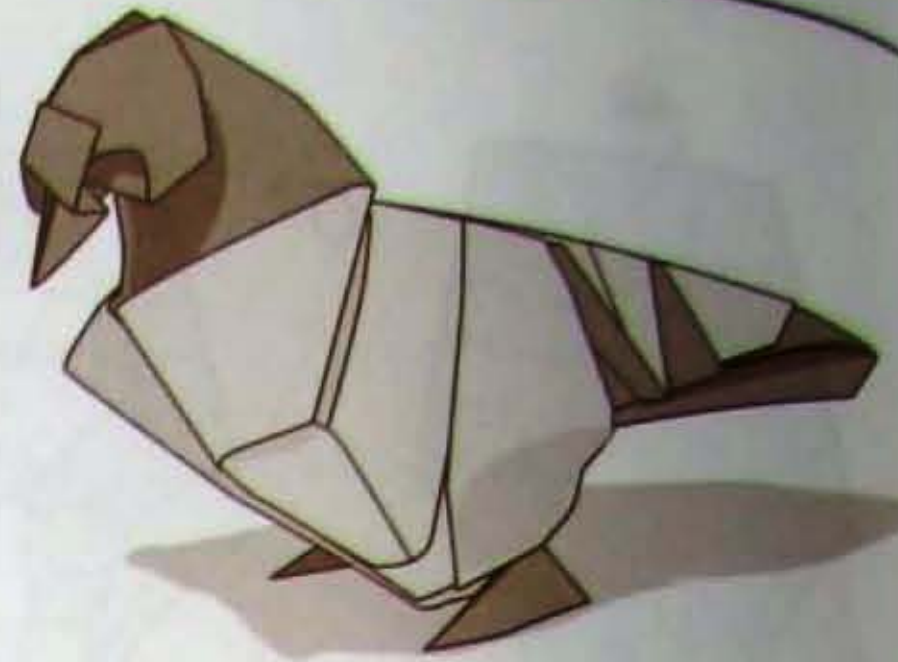

Start with you lighter color facing up.

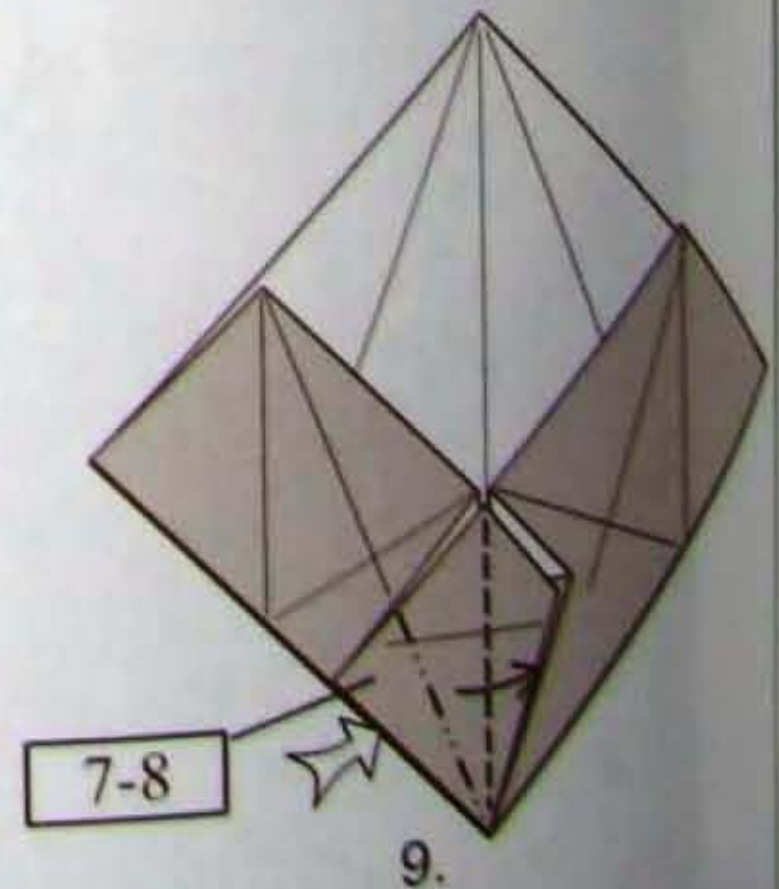
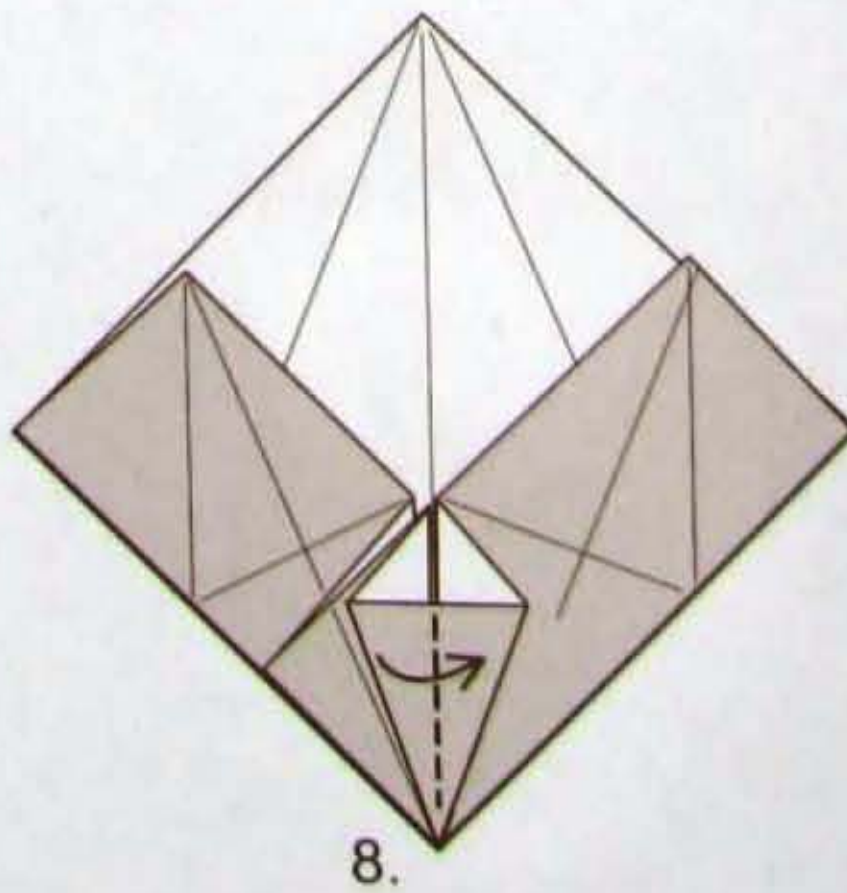
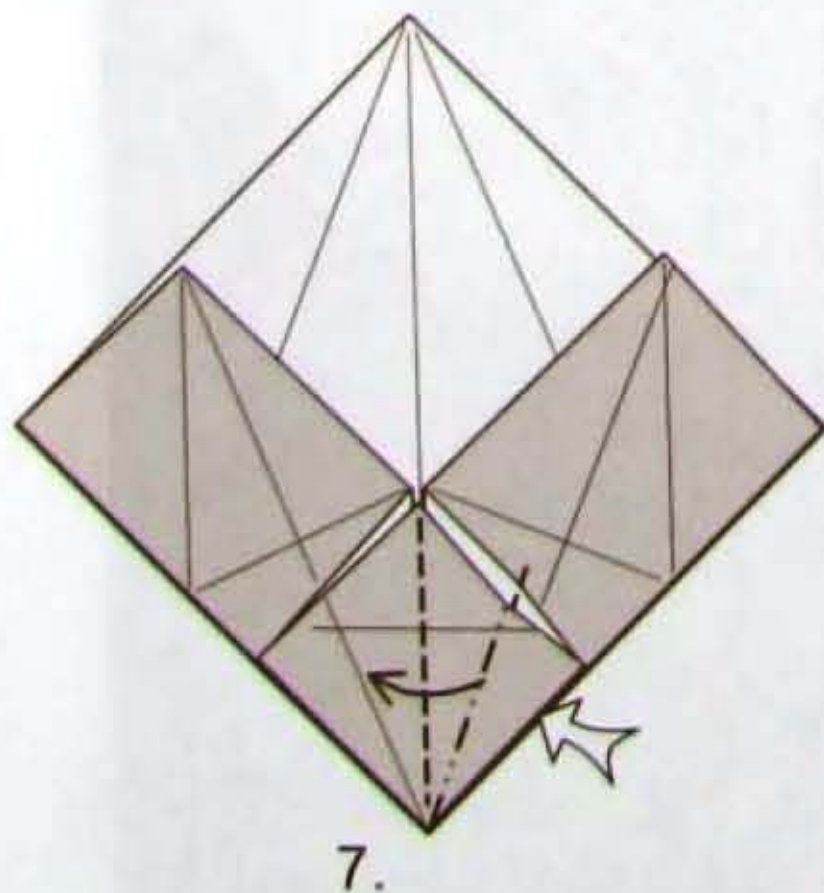
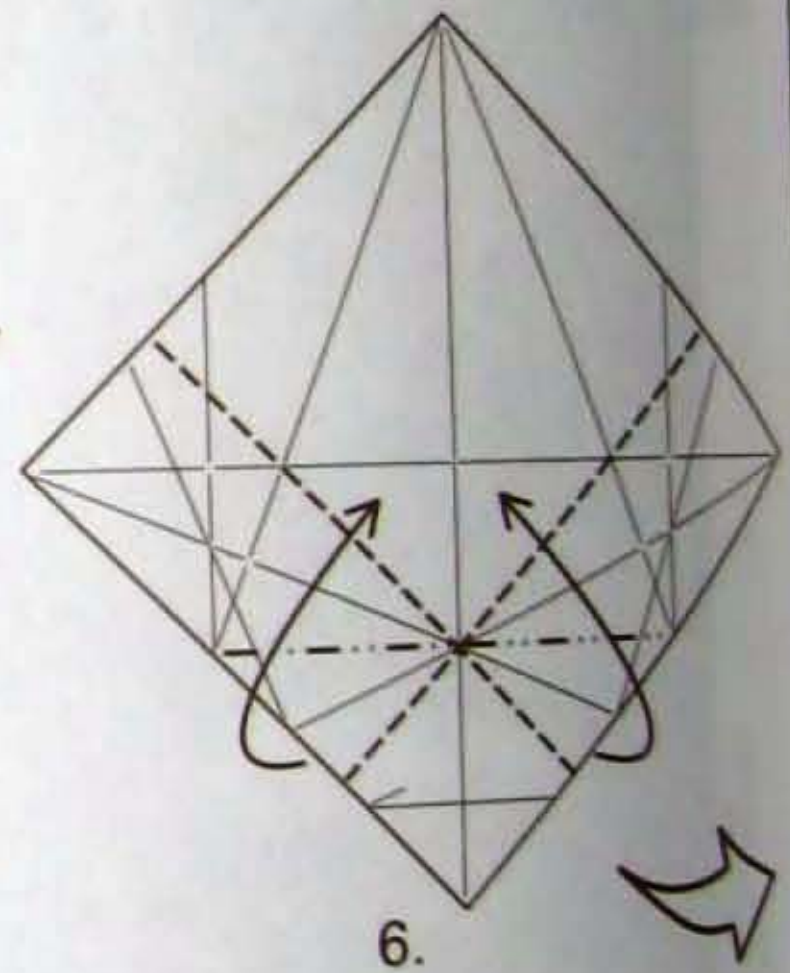
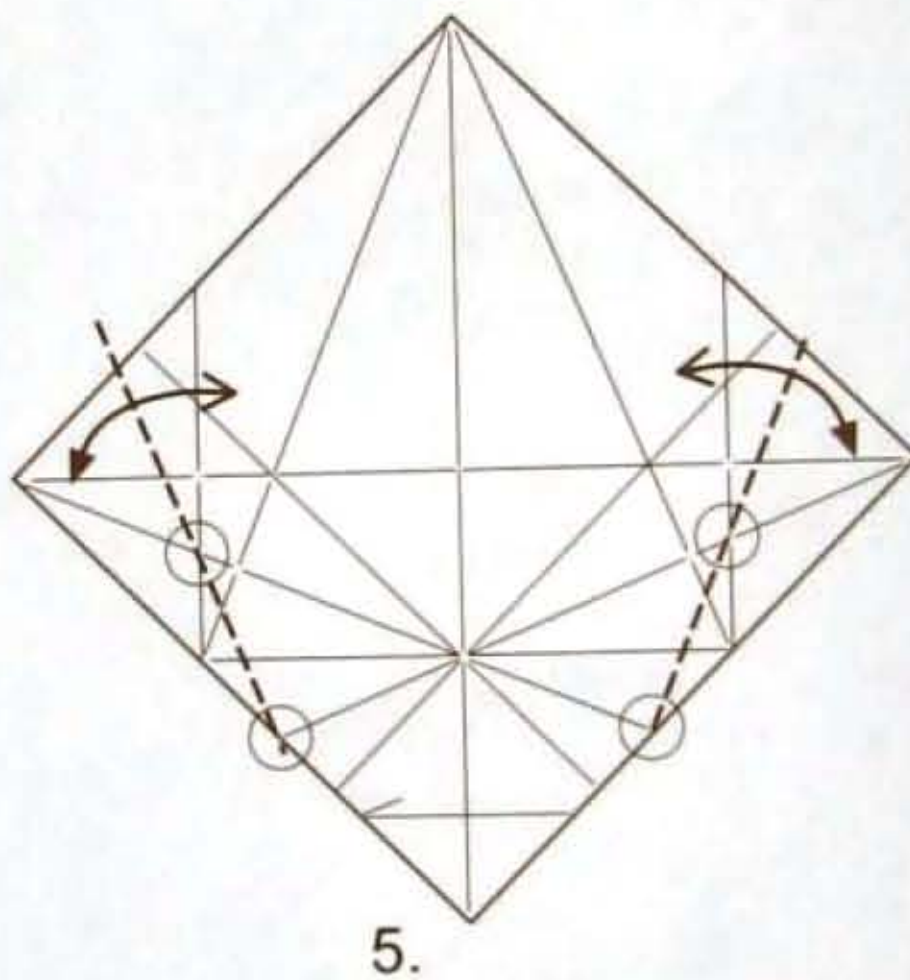
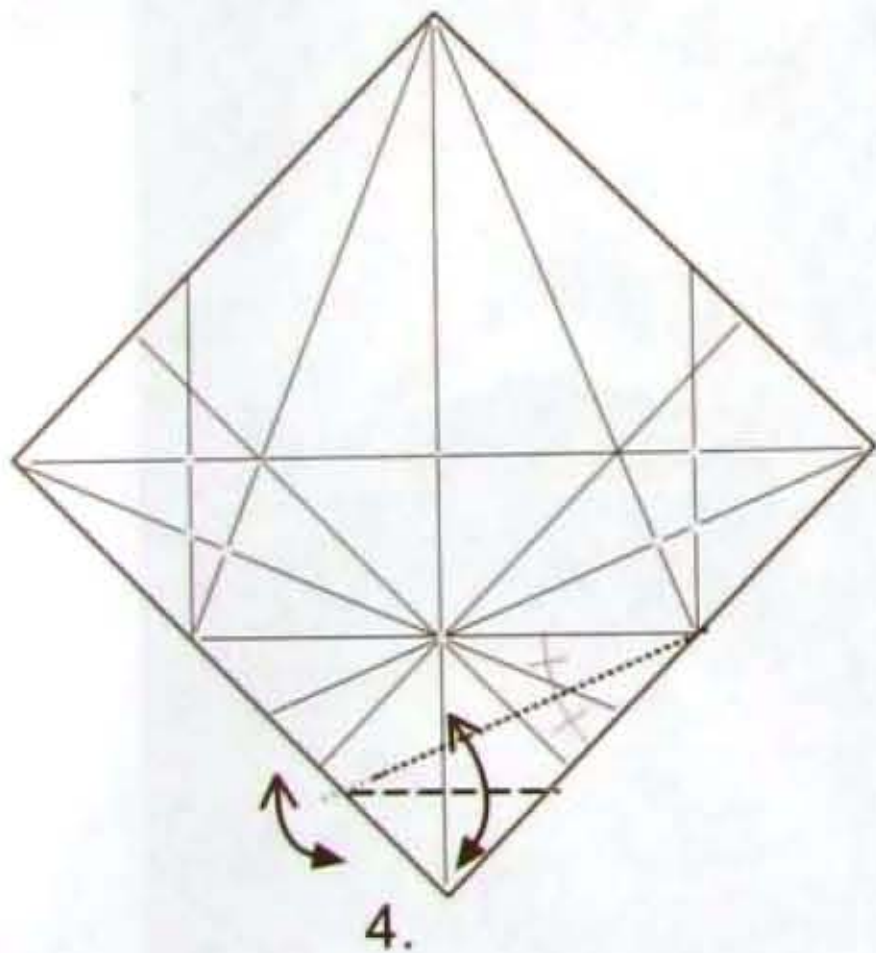
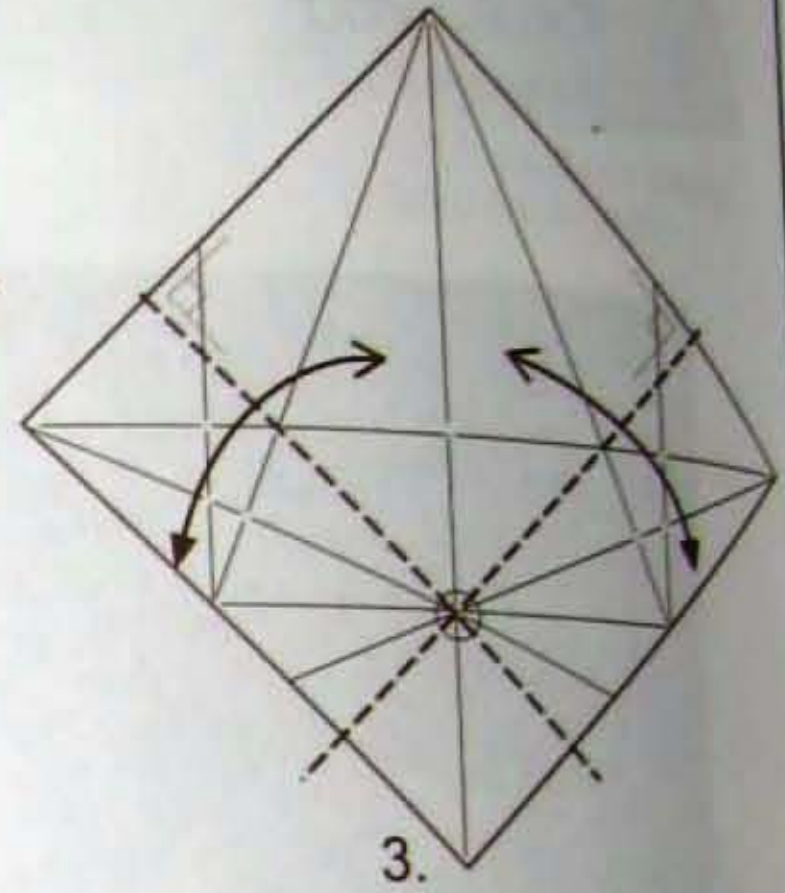
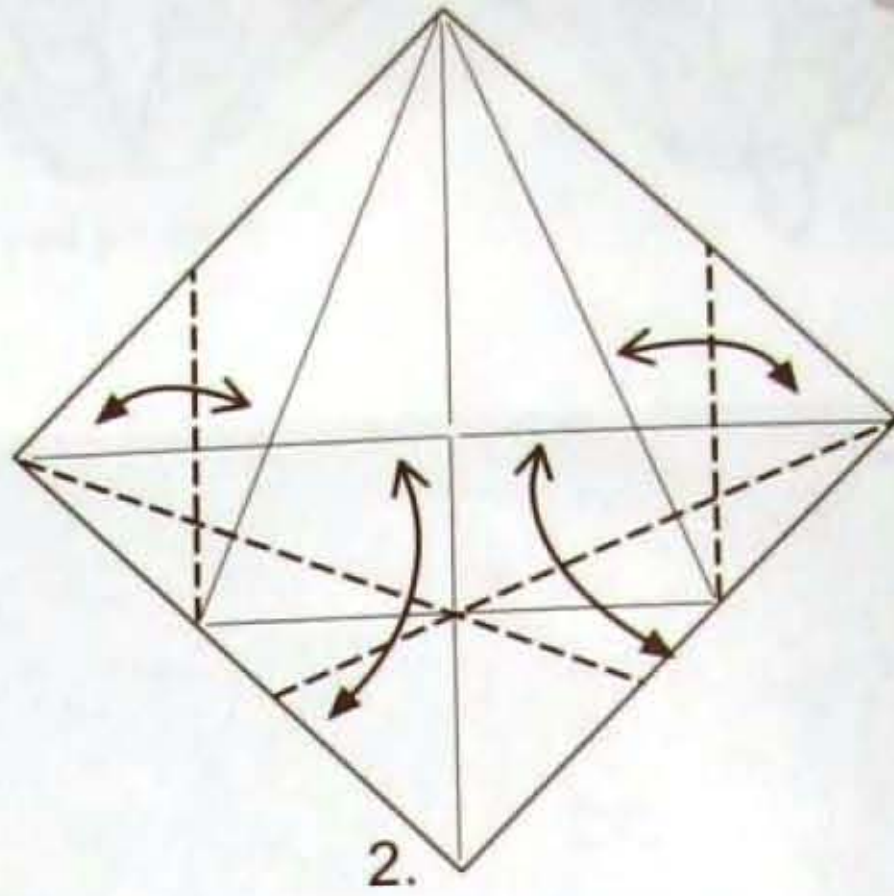
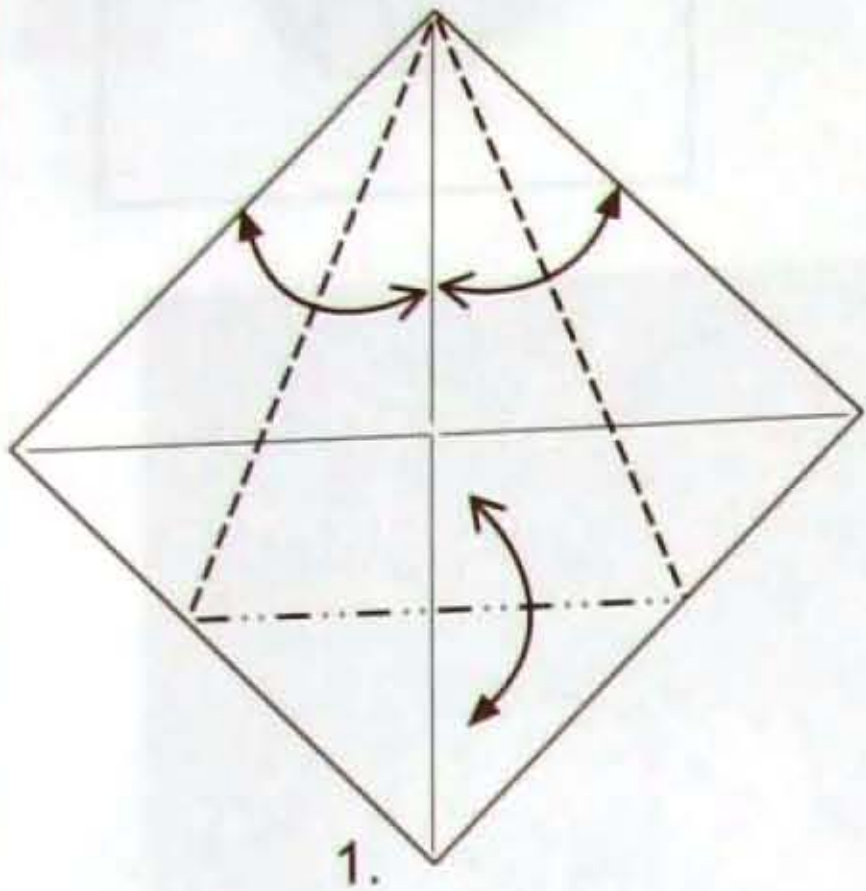

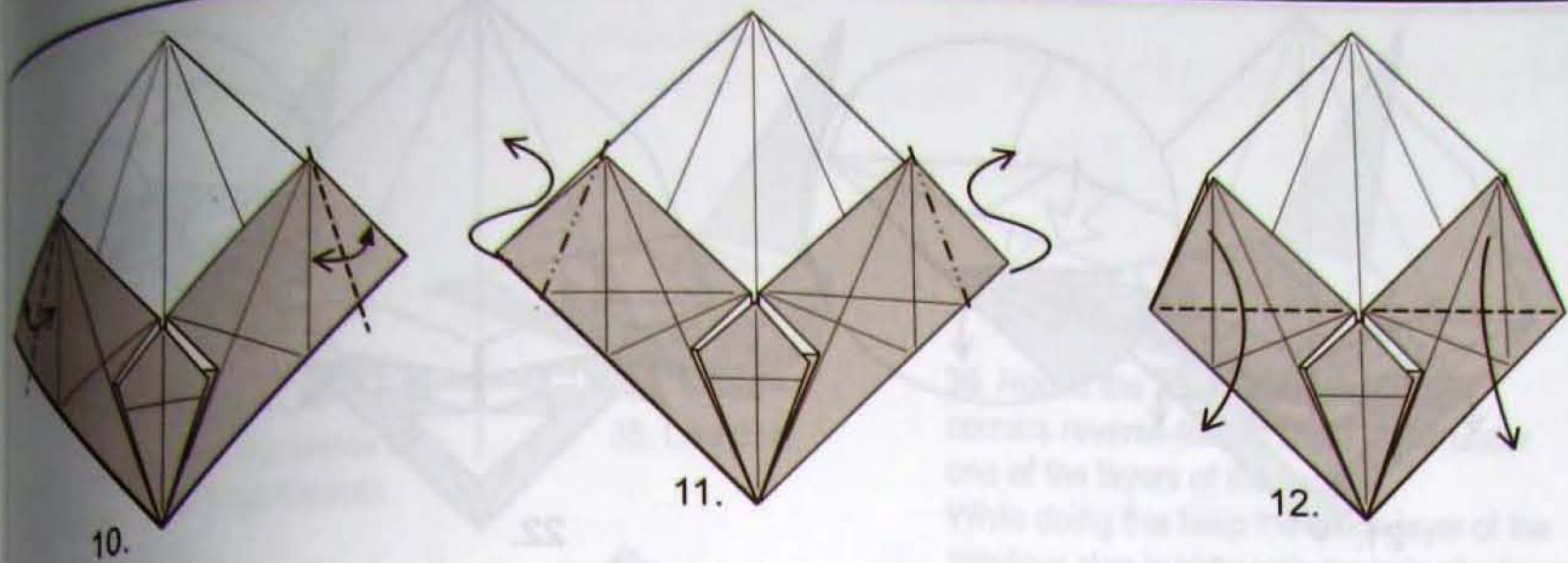

10.

11.

12.

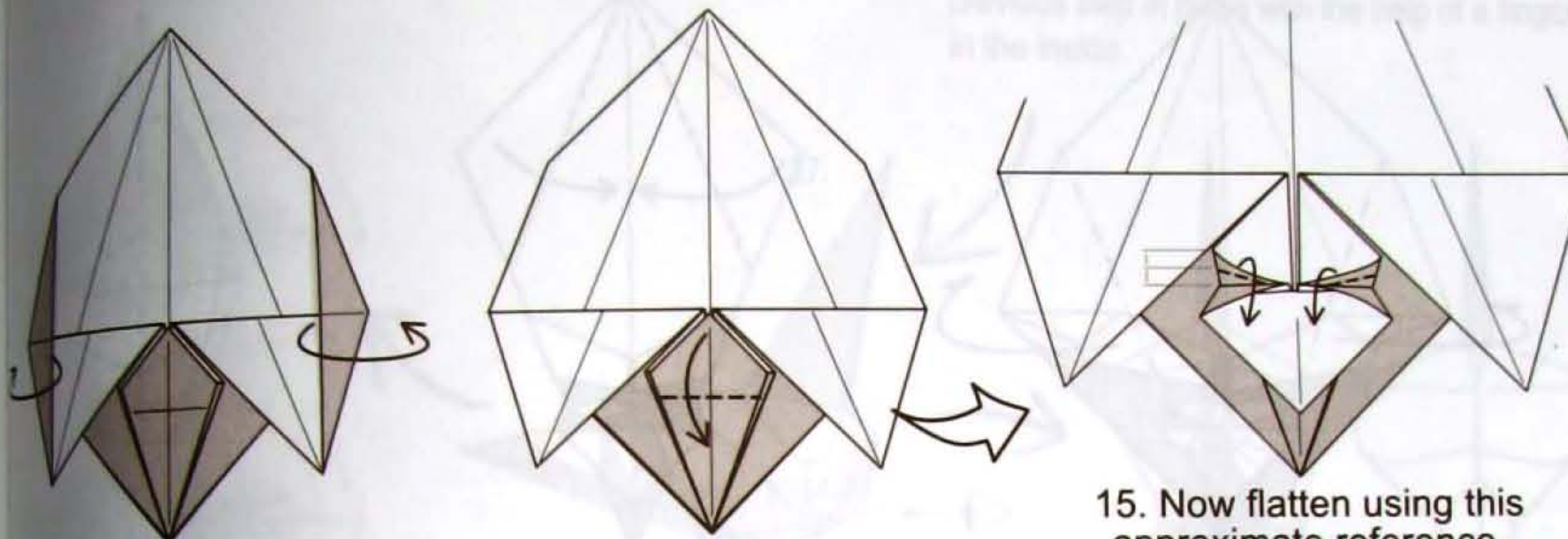

13. Carefully wrap around to color-change.

14. Do not flatten yet.

15. Now flatten using this approximate reference.

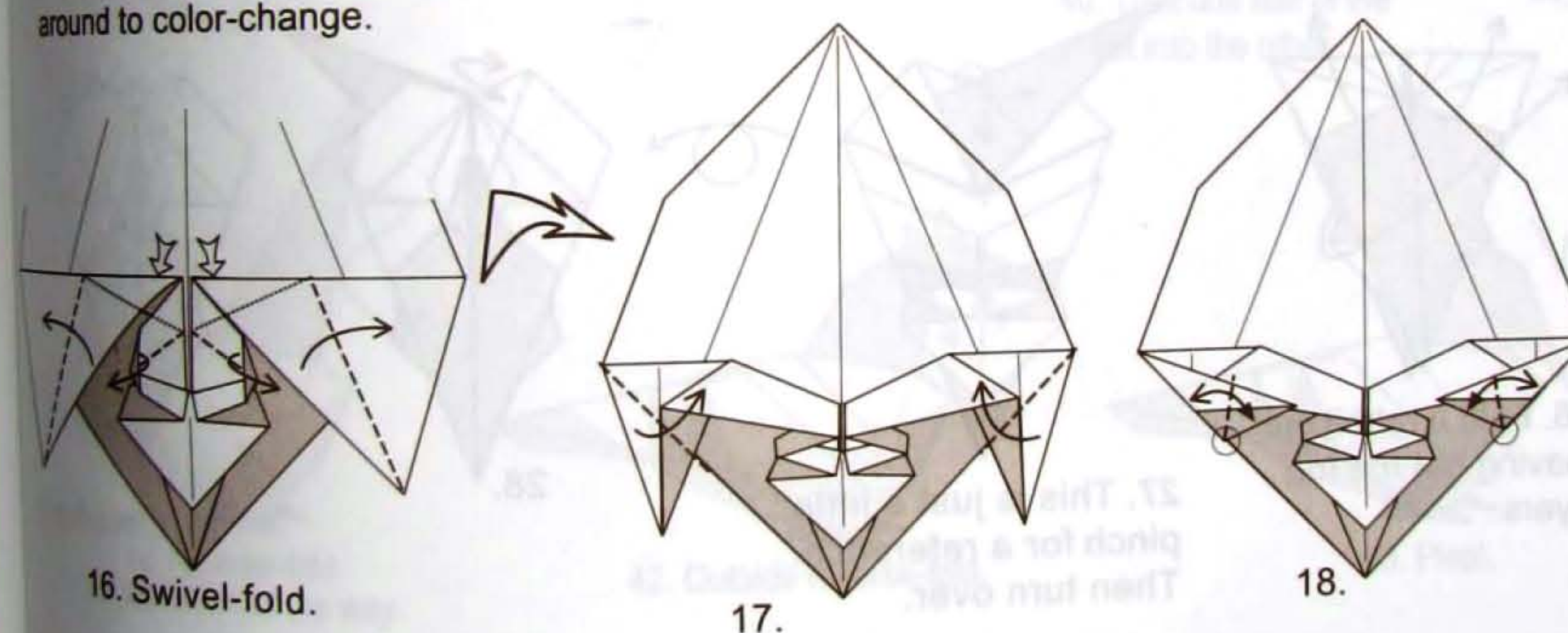

16. Swivel-fold.

17.

18.

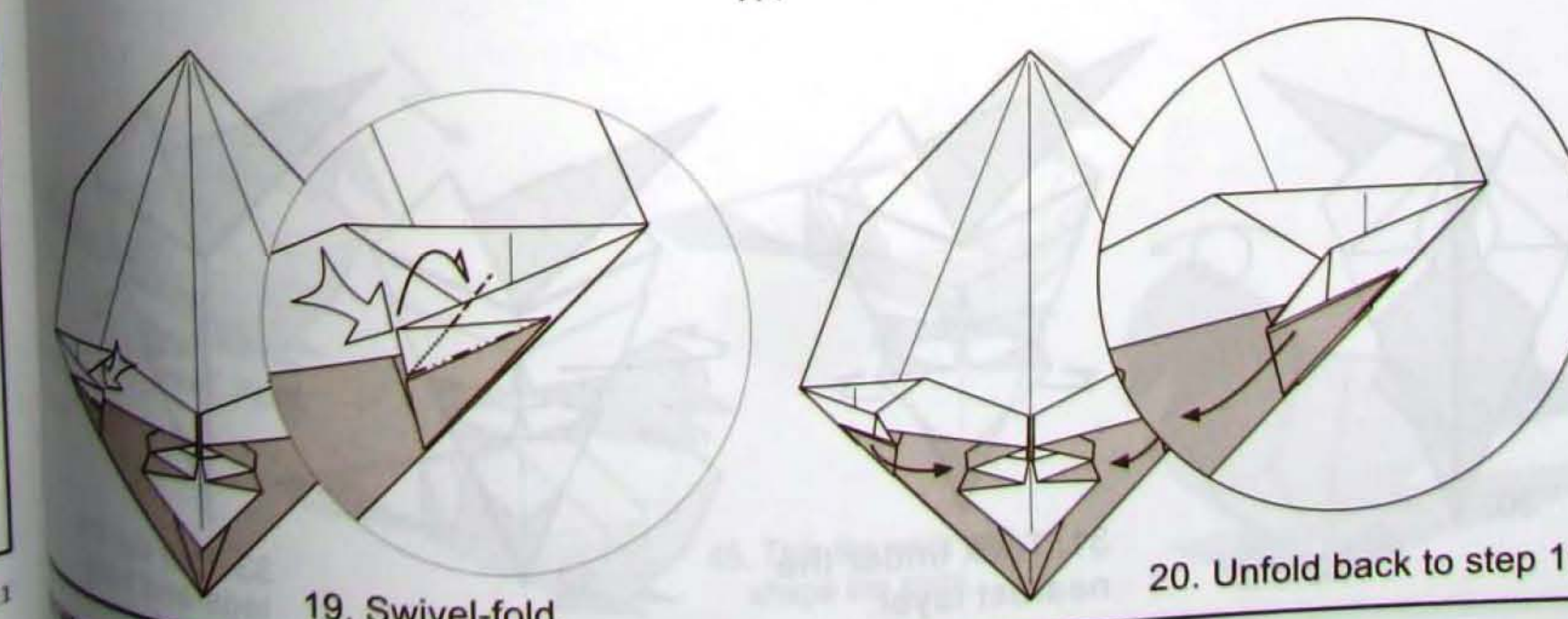

19. Swivel-fold.

20. Unfold back to step 18.

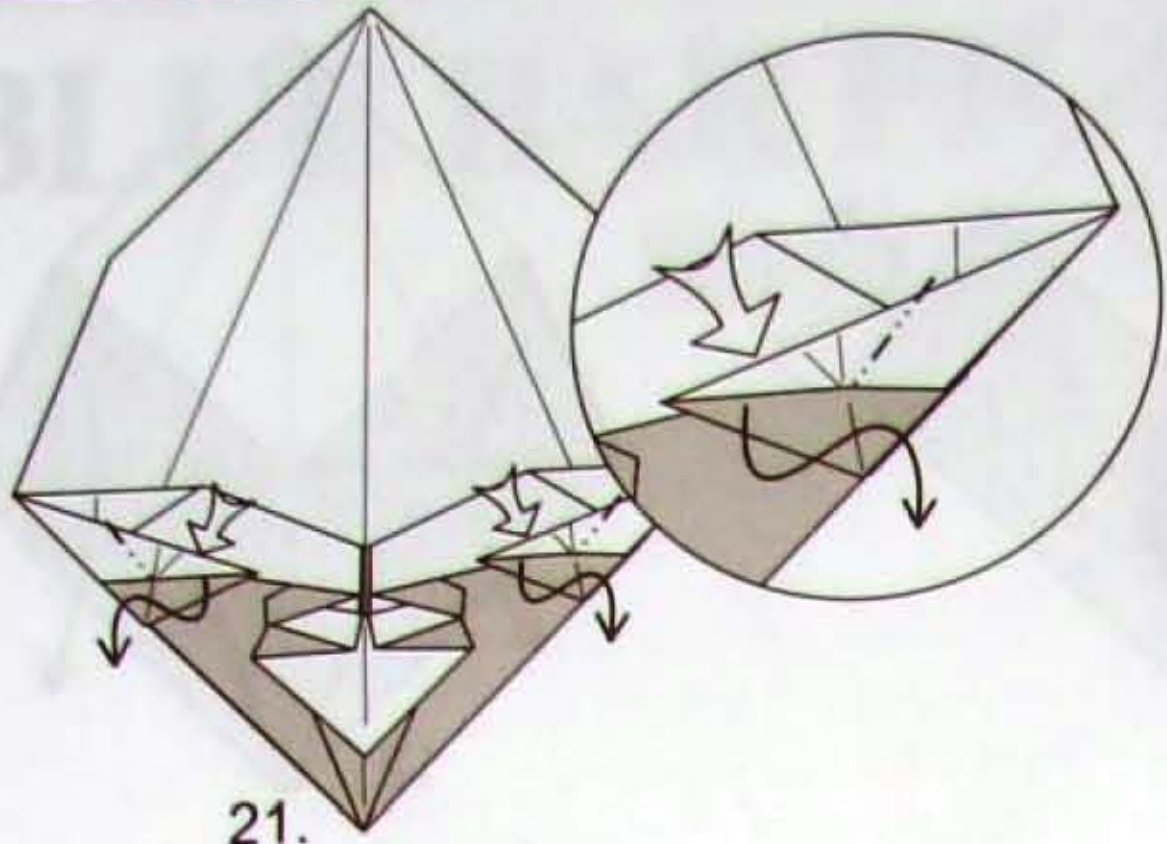

21.

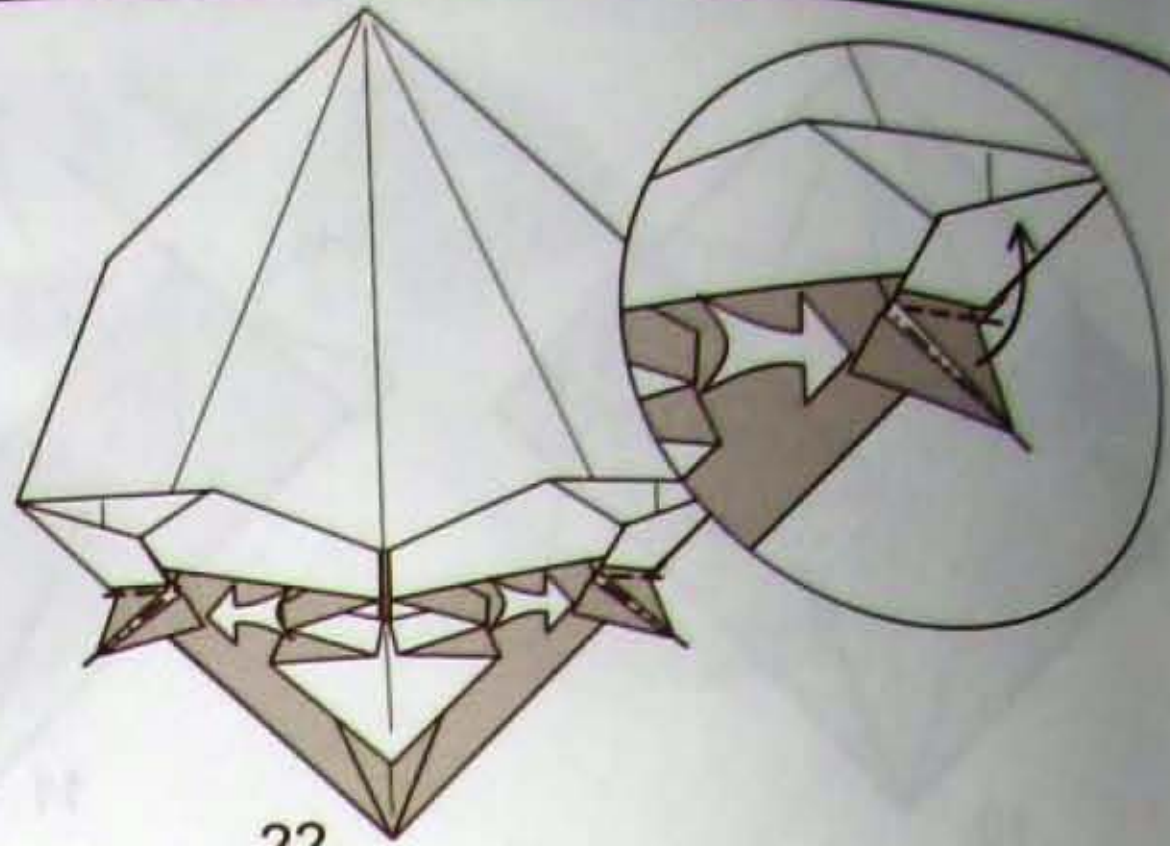

22.

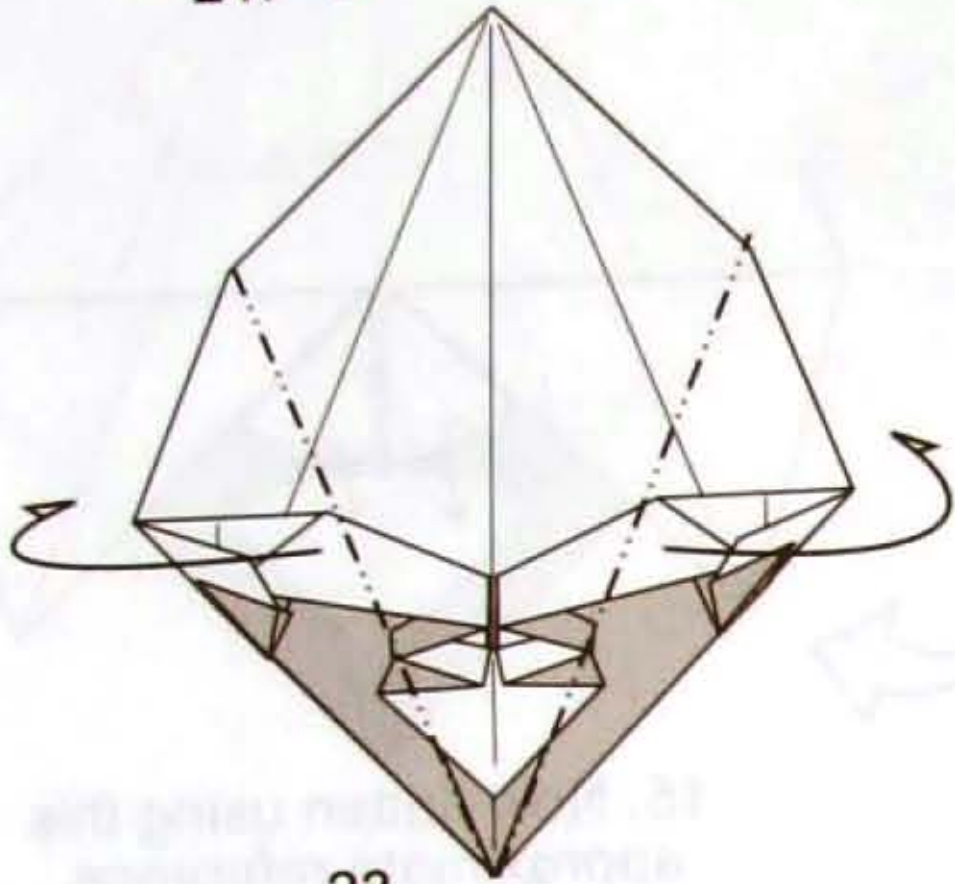

23.

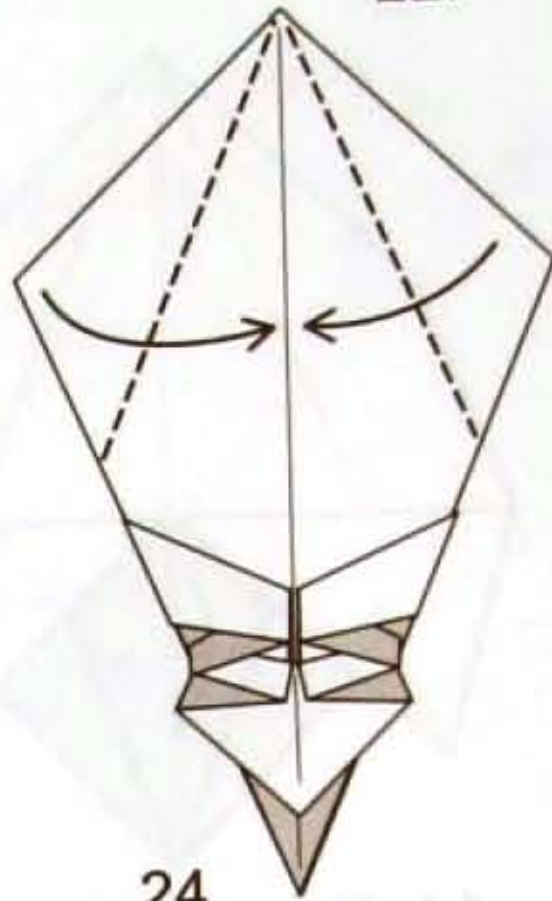

24.

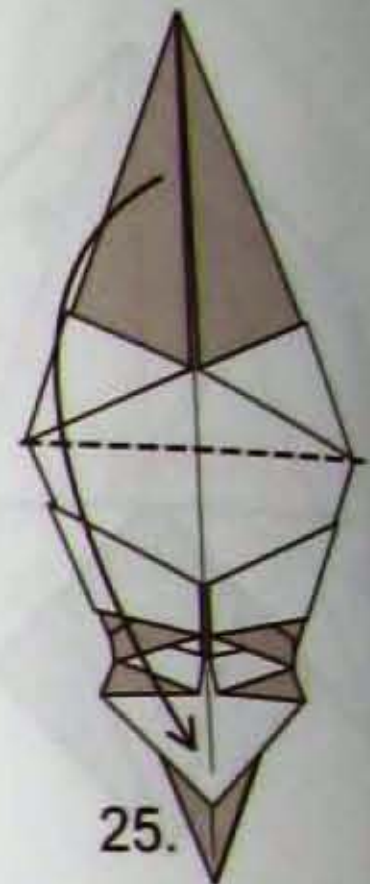

25.

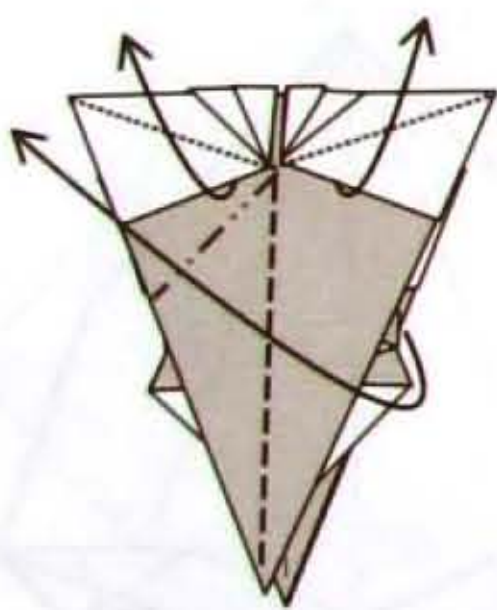

26. Fold a rabbit ear leaving out the top layers.

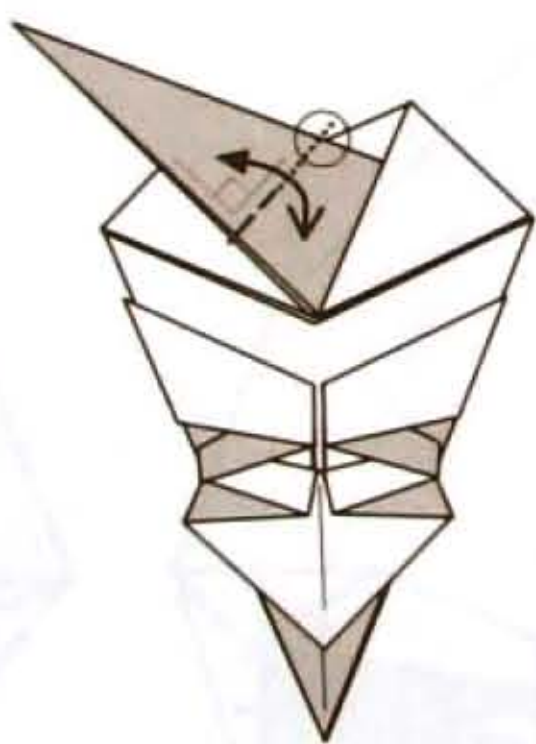

27. This is just a little pinch for a reference. Then turn over.

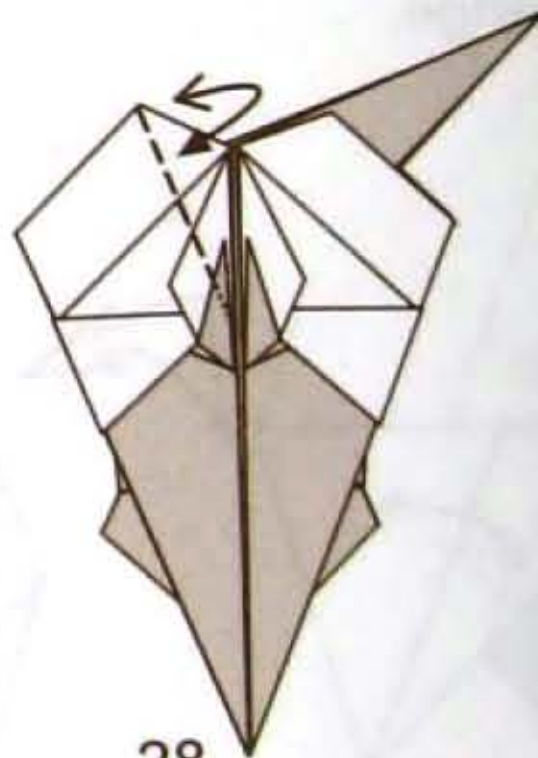

28.

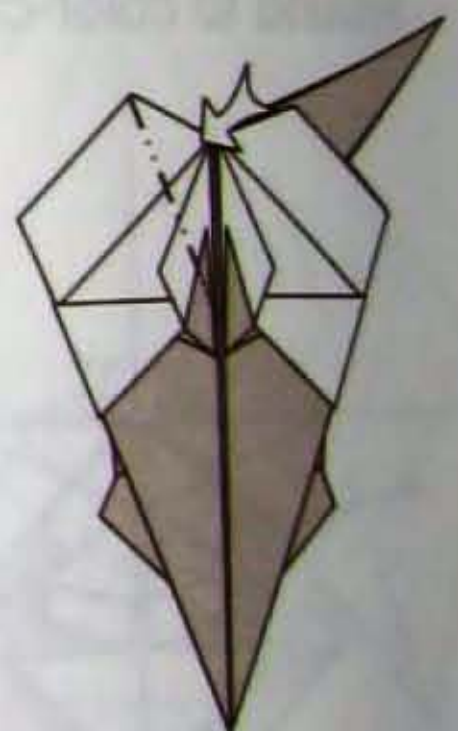

29. Closed-sink.

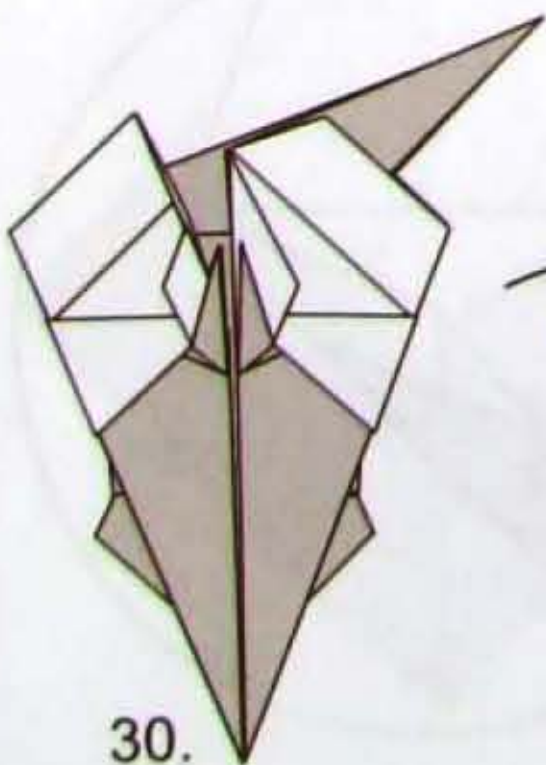

30.

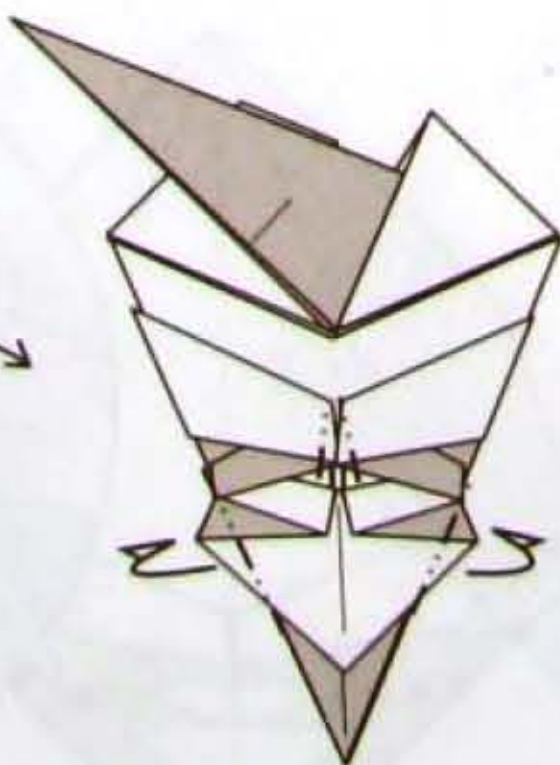

31. Tuck under the nearest layer.

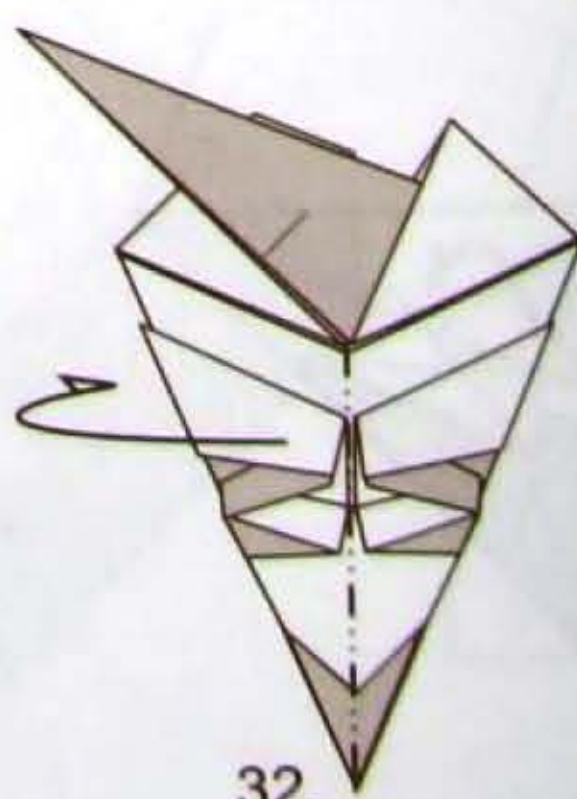

32.

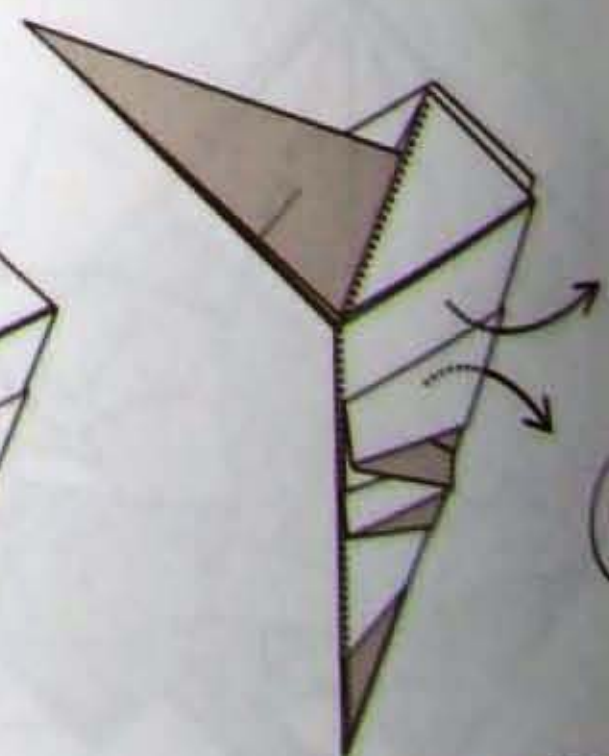

33. Pull out the legs and belly.



34. Find an edge in the inside of the neck and fold it backwards as far as it will go.

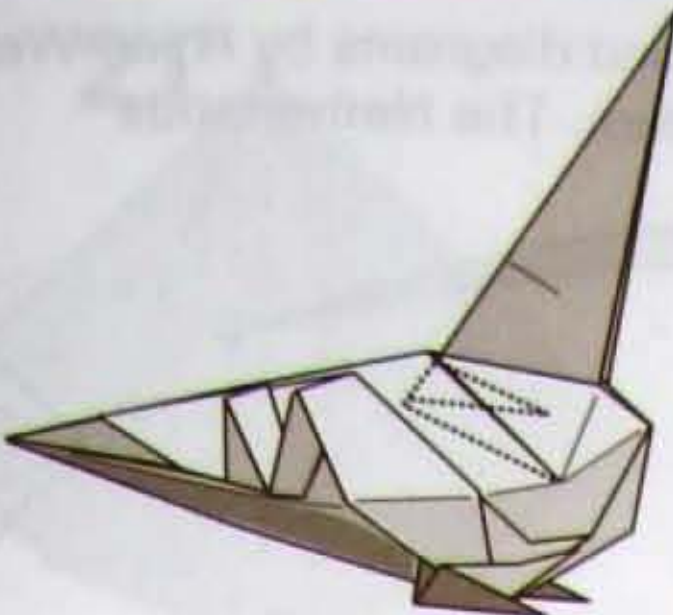

35. Like this.

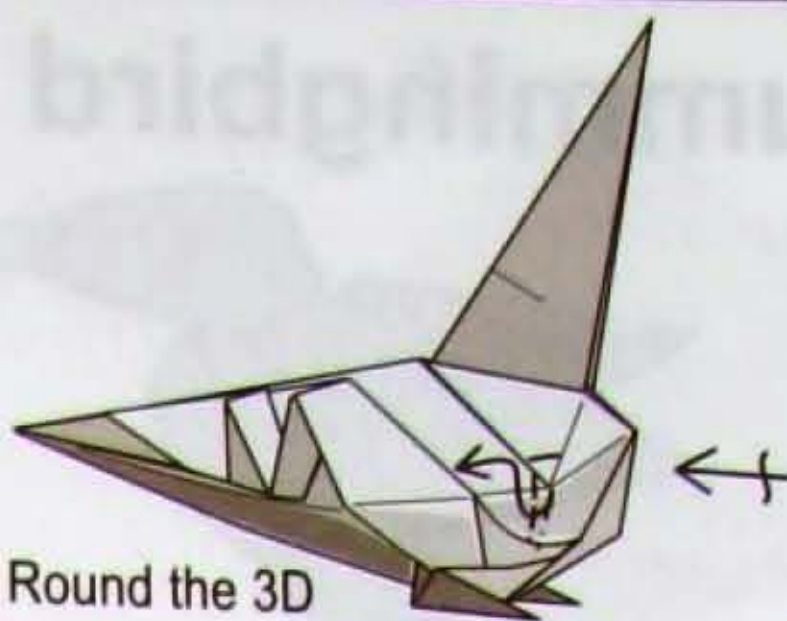

36. Round the 3D corners reverse-folding some paper under one of the layers of the neck. While doing this keep the inside layer of the previous step in place with the help of a finger in the inside.

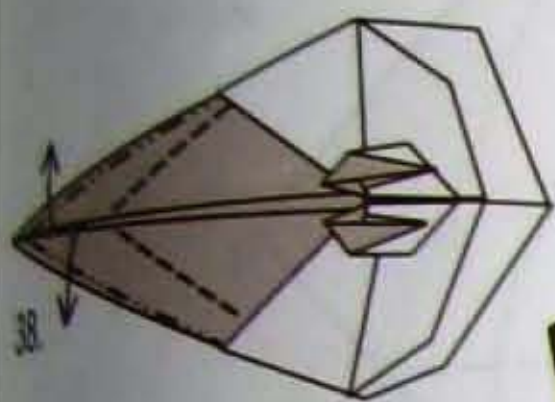

37.

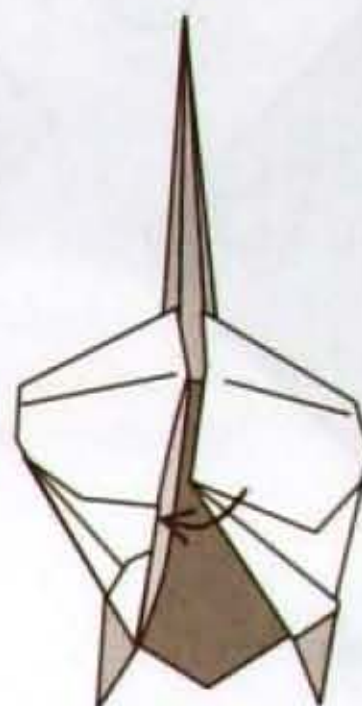
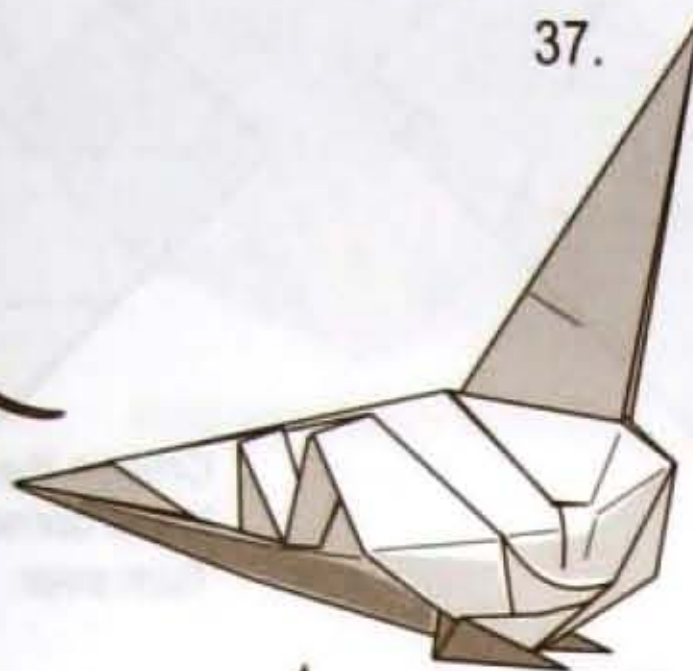

40. Tuck one half of the chest into the other.

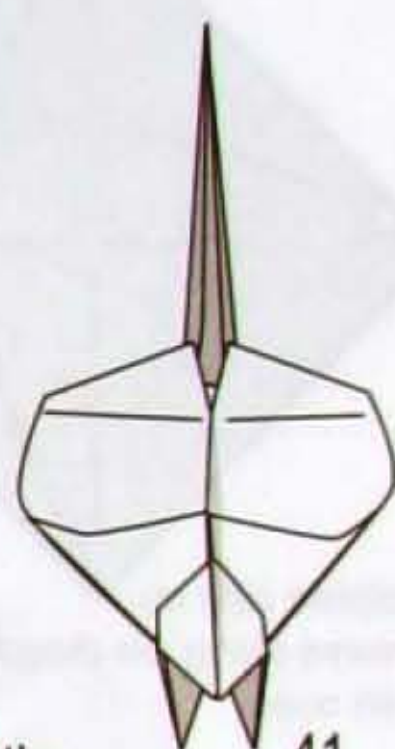

41.

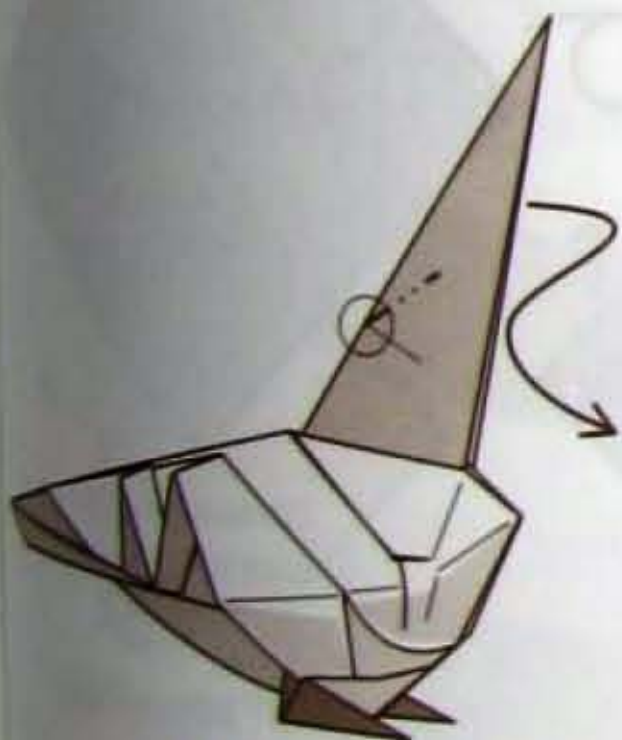

42. Reverse-fold. Do not flatten all the way.

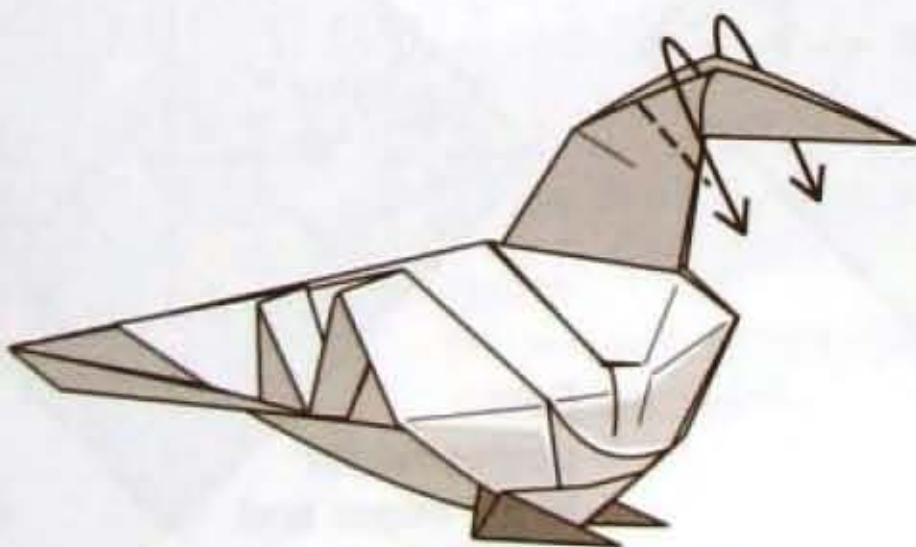

42. Outside reverse-fold.

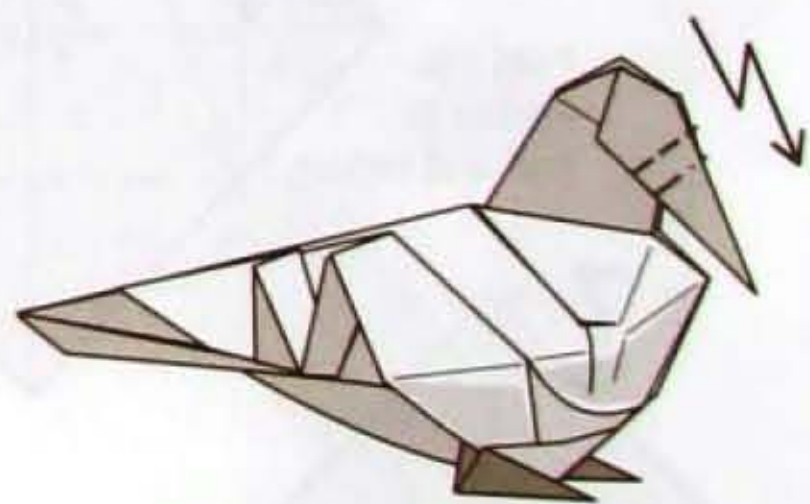

43. Pleat.



44. Pleat.

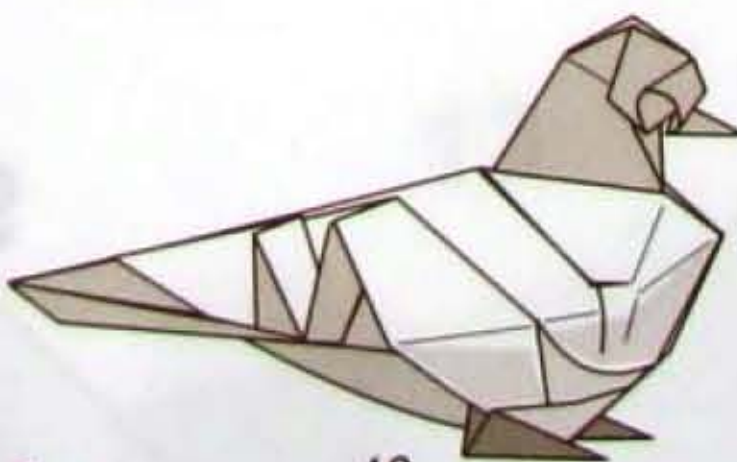

46

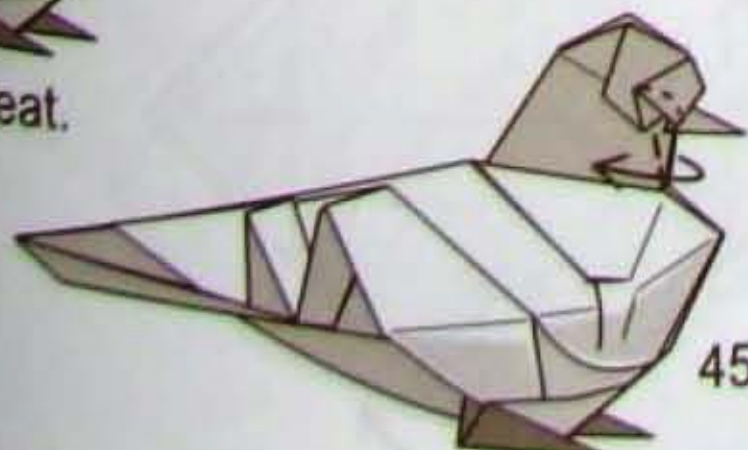

45. Thin the neck and shape the eyes.

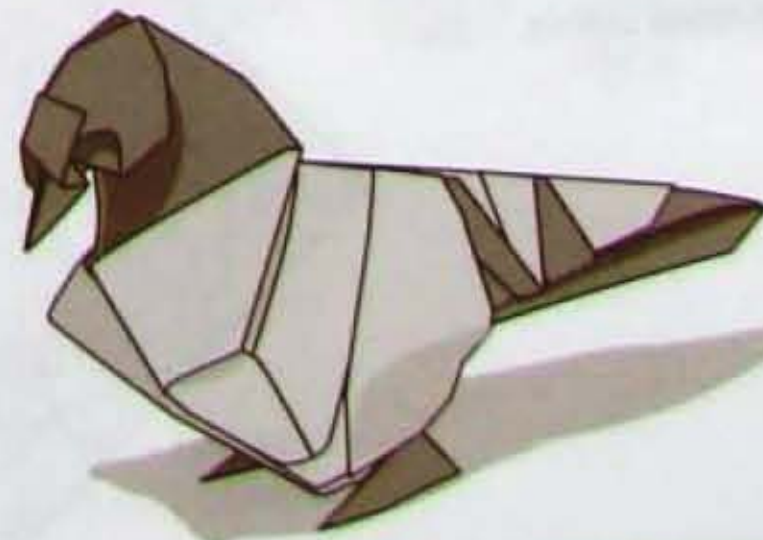

ed-sink.

ut the belly.

17th Convention 2011

Hummingbird

Design and diagrams by Ryan Welsh
Amsterdam, The Netherlands

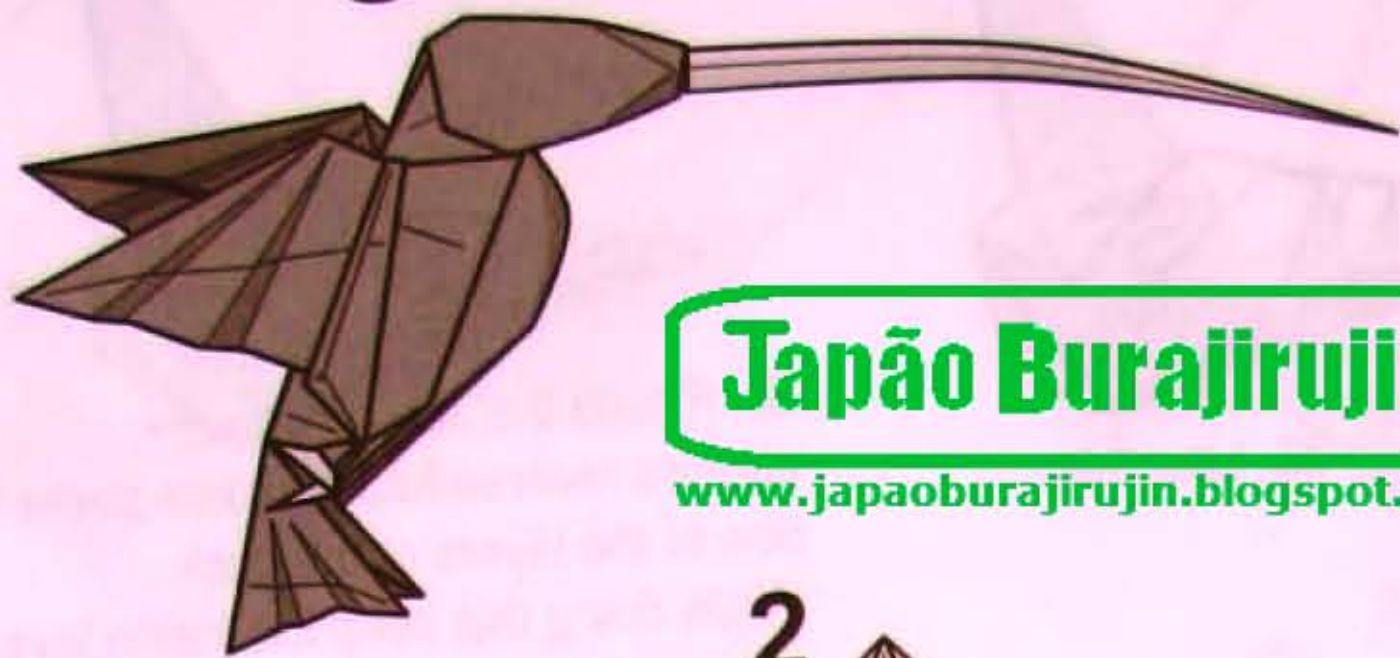

Japão Burajirujin
www.japaoburajirujin.blogspot.com

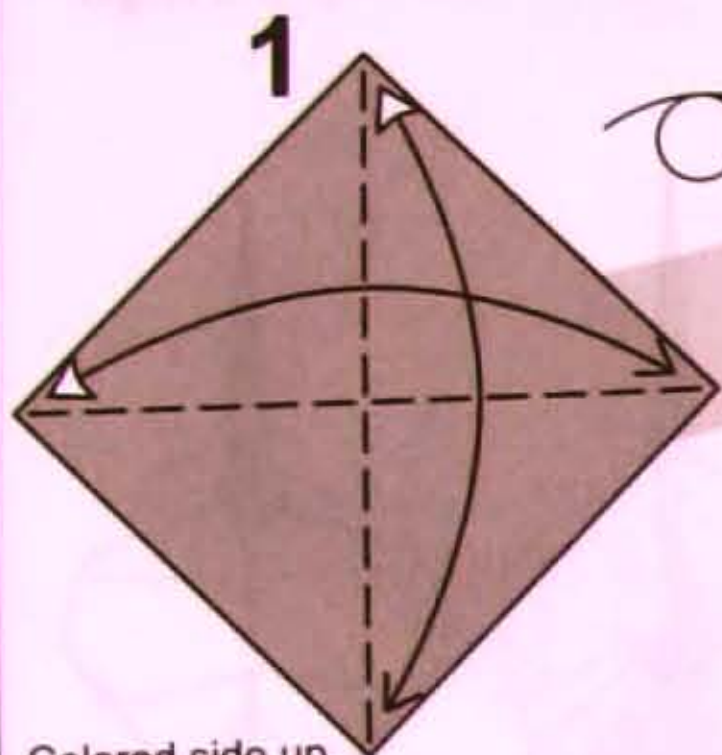
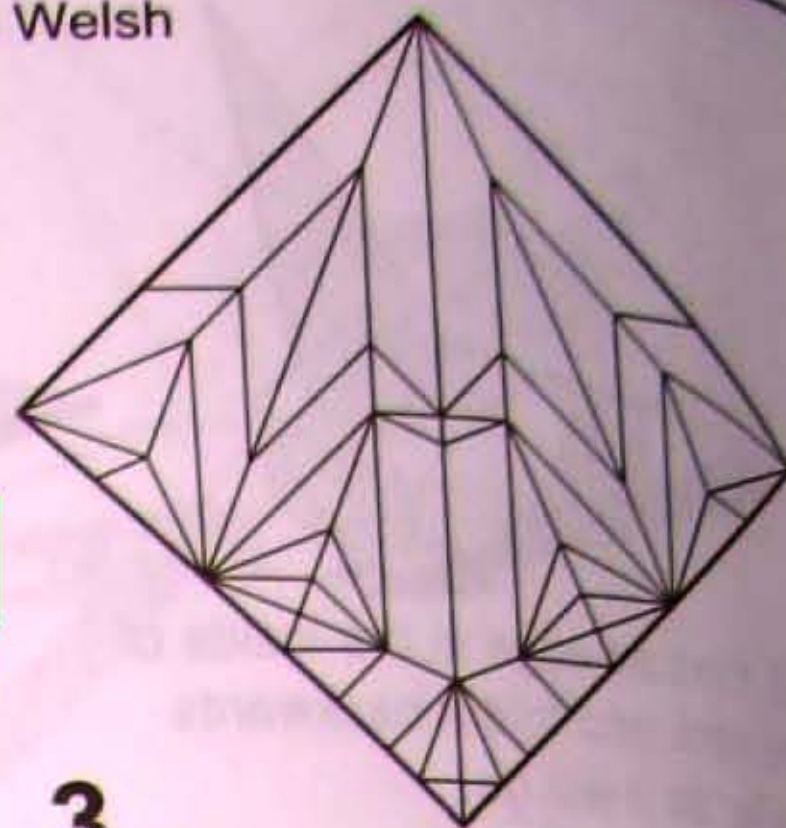

1
Colored side up.
Crease along the diagonals.
Turn over.

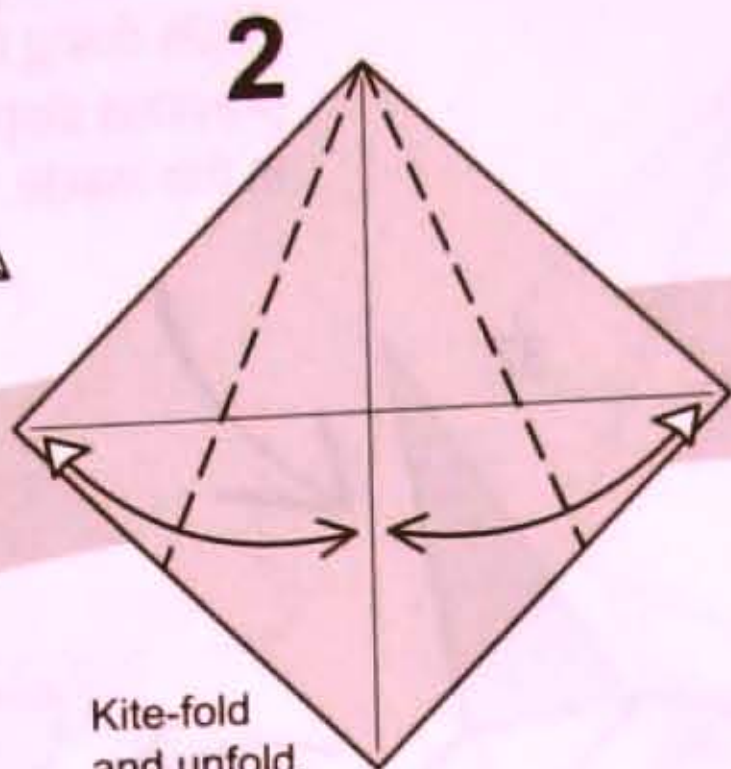

2
Kite-fold
and unfold.

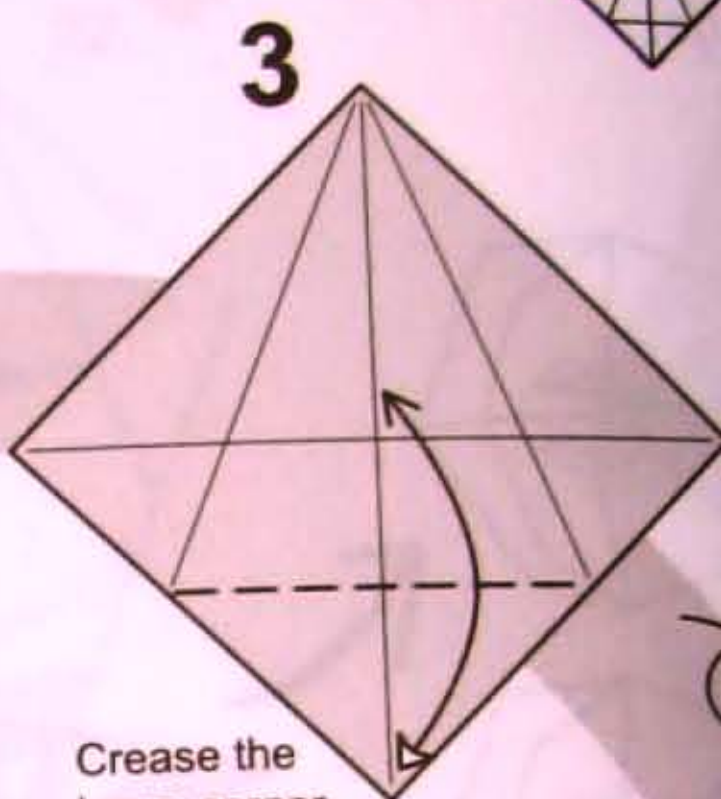

3
Crease the
lower corner.
Turn over.

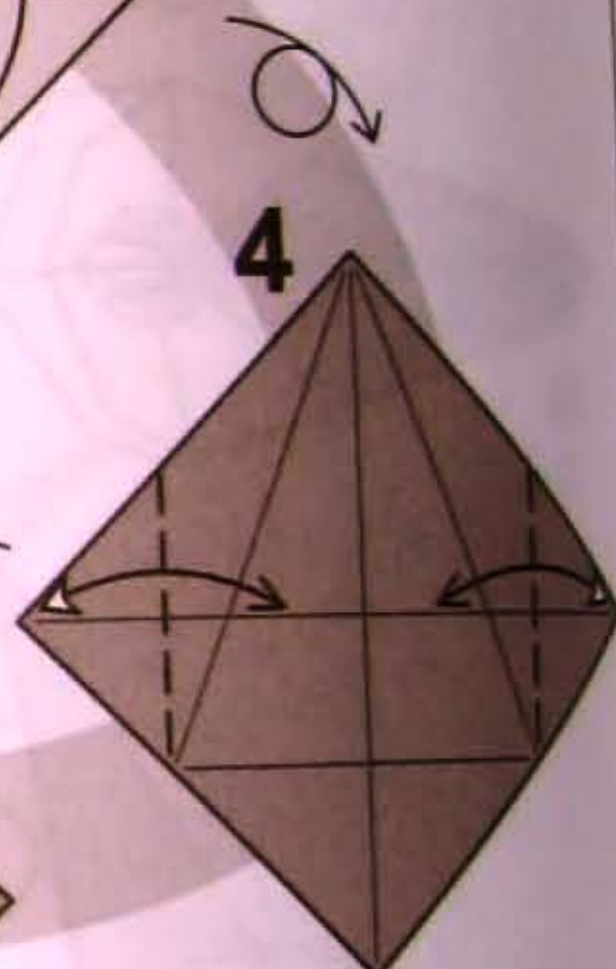

4
Crease the outer
corners.

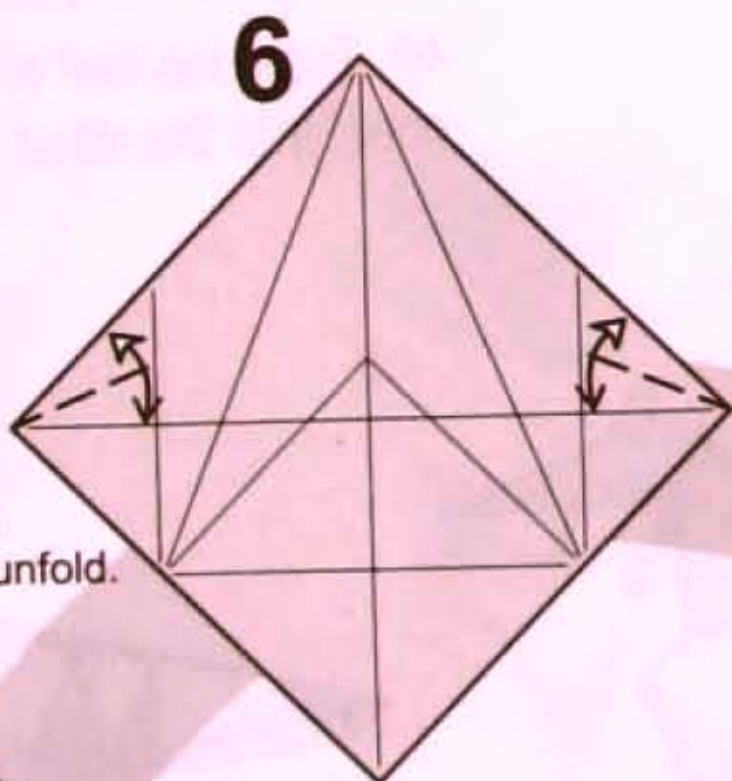

5
Fold the
angles in
half and unfold.

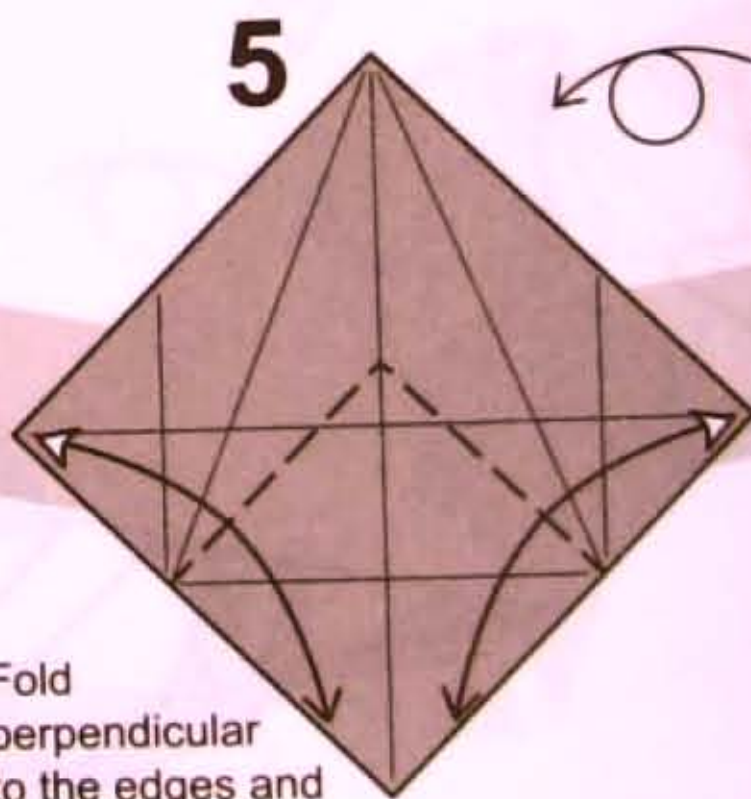

6
Fold
perpendicular
to the edges and
unfold. Turn over.

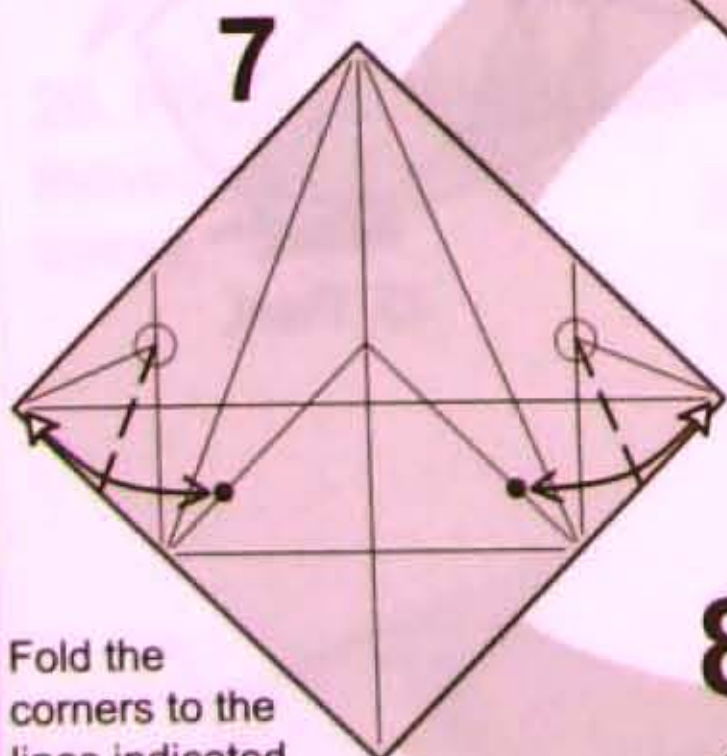

7
Fold the
corners to the
lines indicated
starting at the
encircled points.

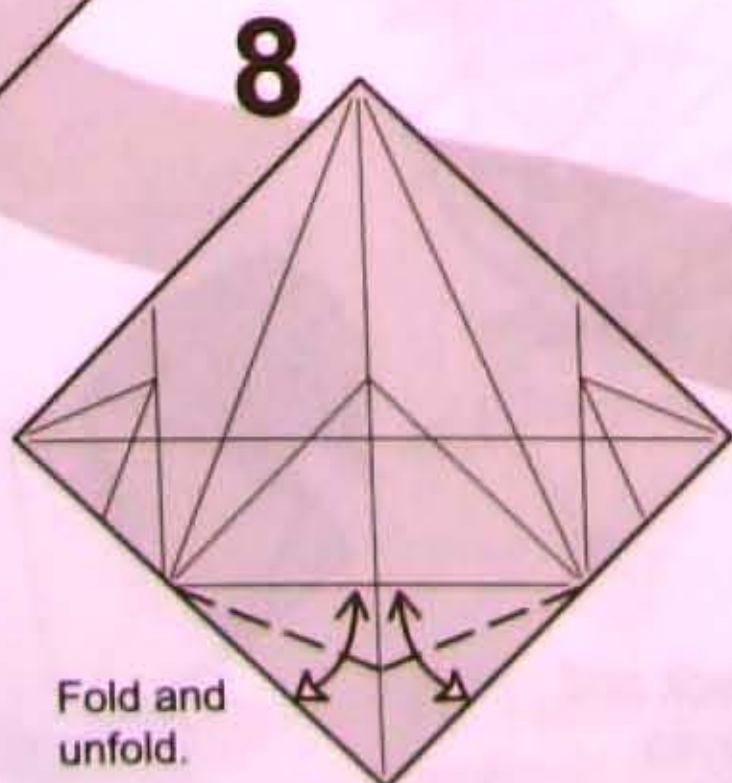

8
Fold and
unfold.

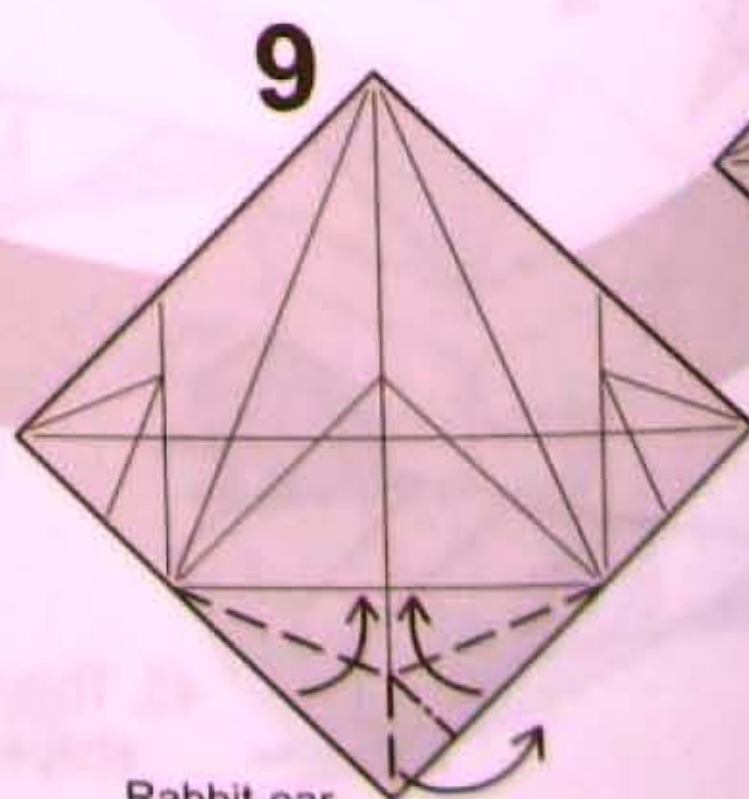

9
Rabbit-ear.

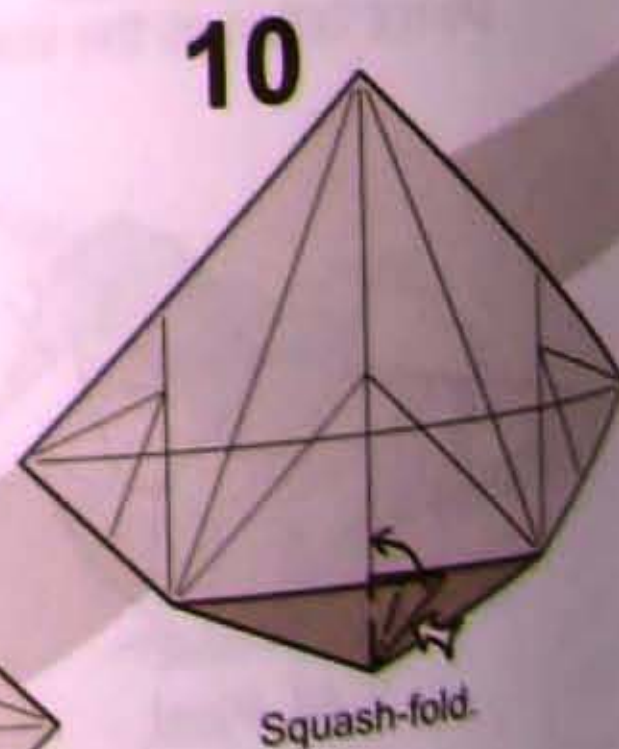

10
Squash-fold.



20

Turn over.

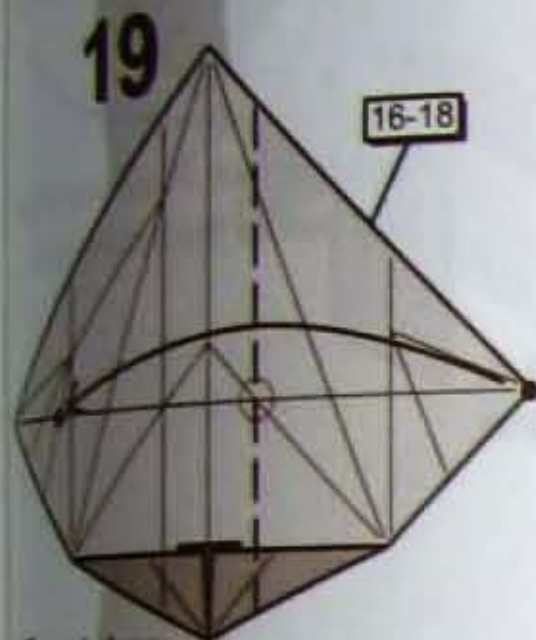

19

16-18

Repeat steps 16-18 on the right.

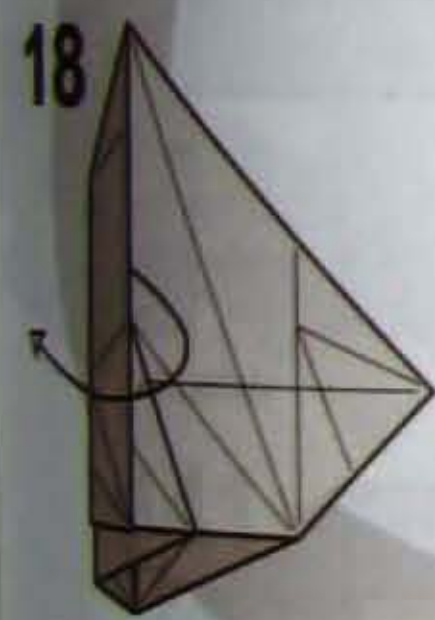

18

Unfold to step 16.

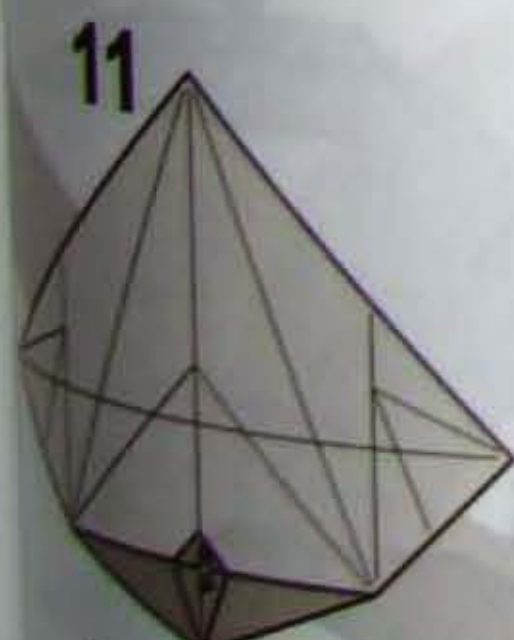

11

Fold and unfold.

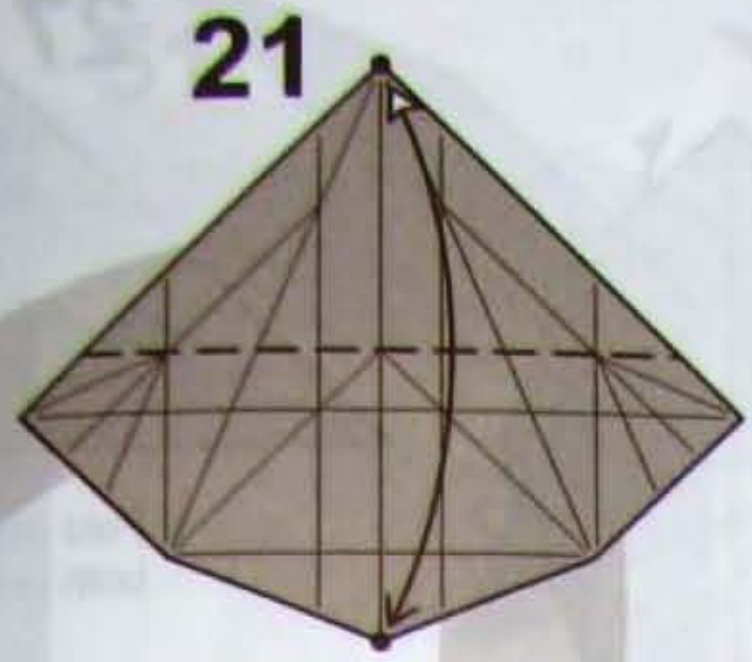

21

Fold and unfold.

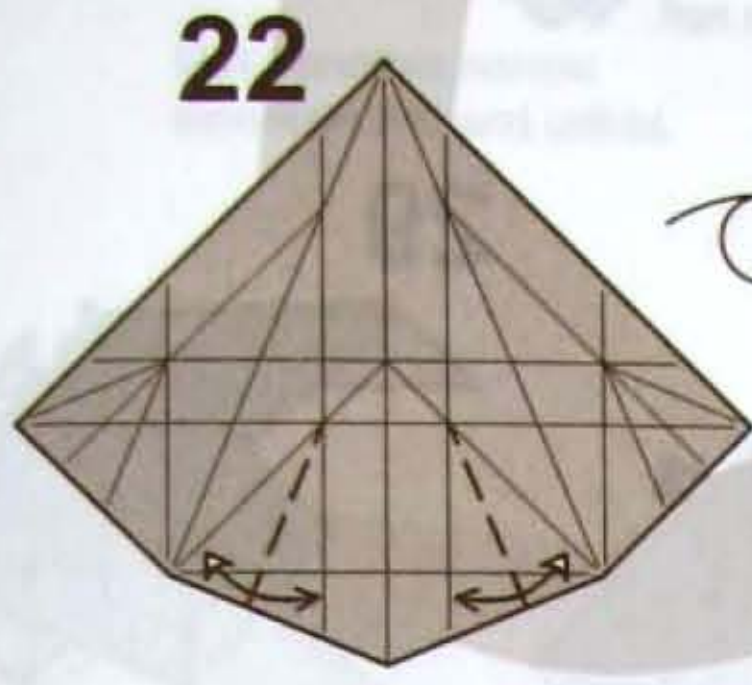

22

Fold and unfold. Turn over.

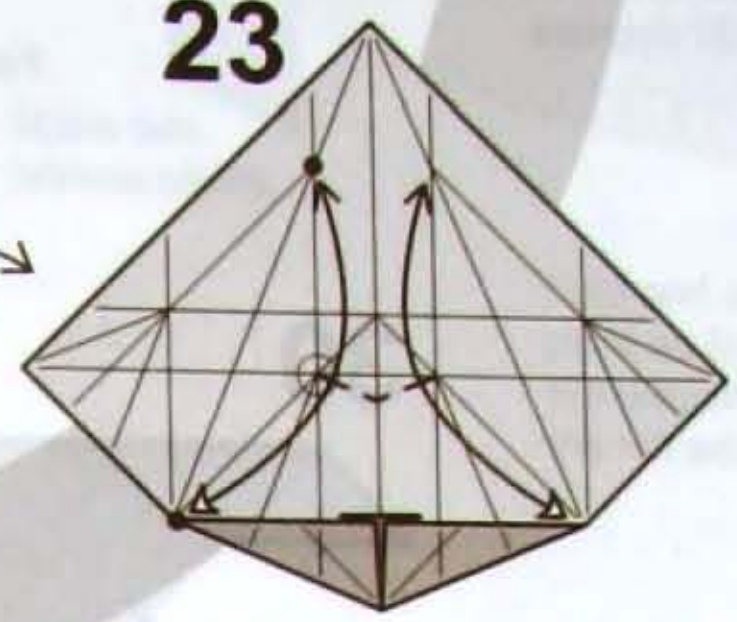

23

Make a small crease by bringing the corner to the intersection shown. Repeat on the right.

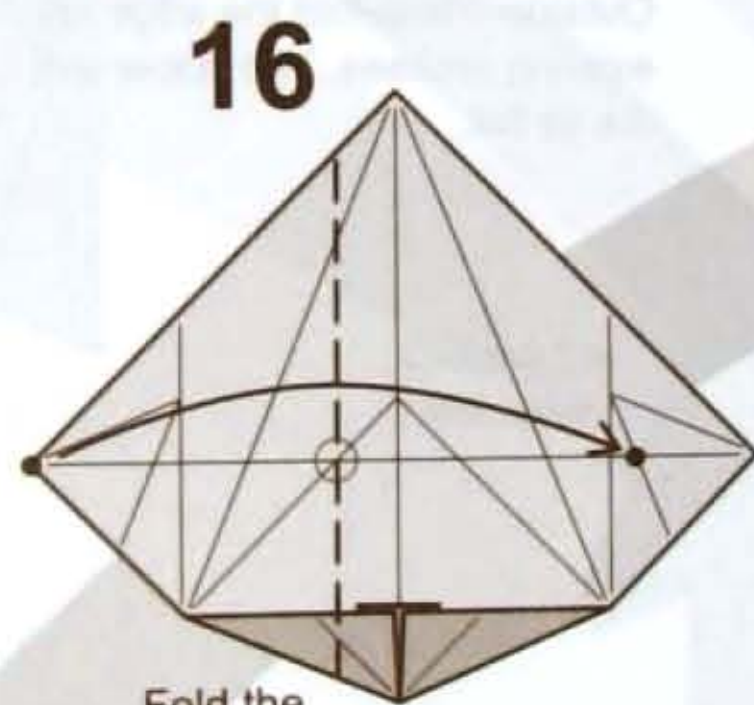

16

Fold the left corner to the intersection of creases shown.

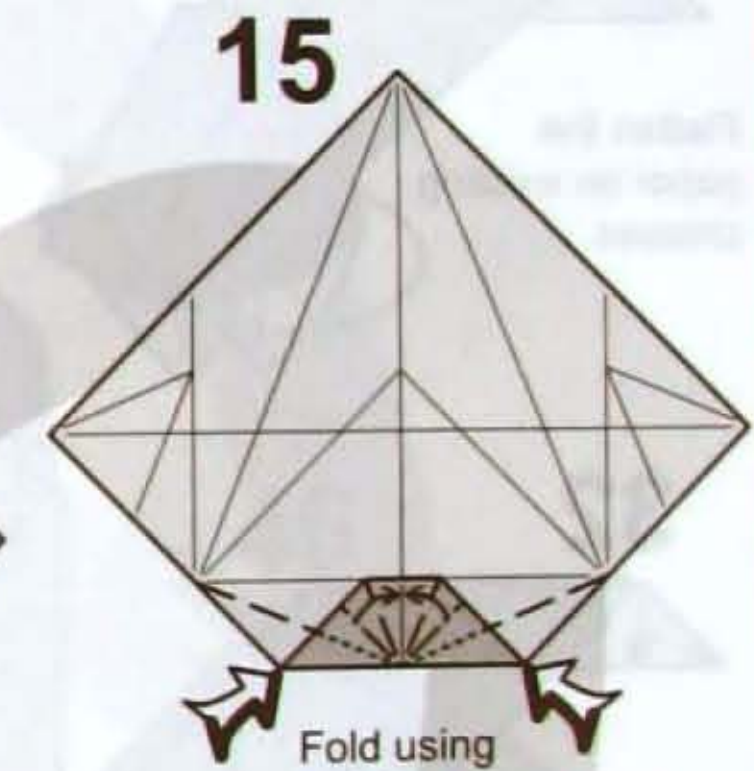

15

Fold using existing creases.

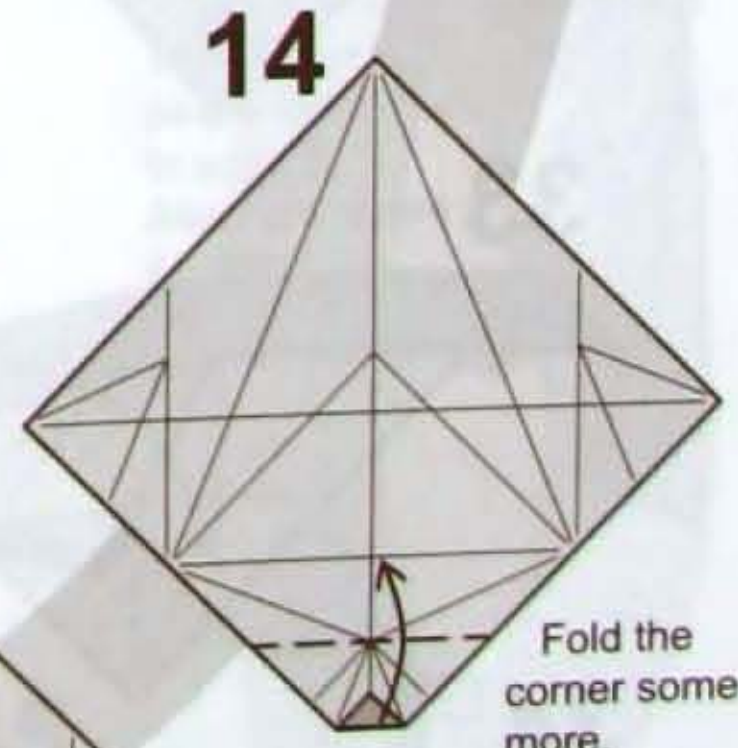

14

Fold the corner some more.

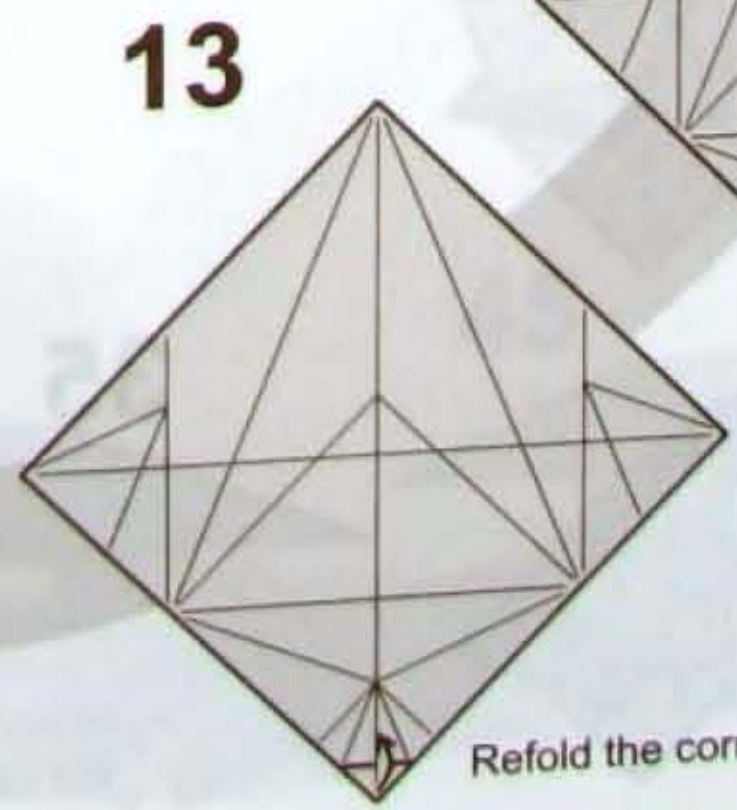

13

Refold the corner.

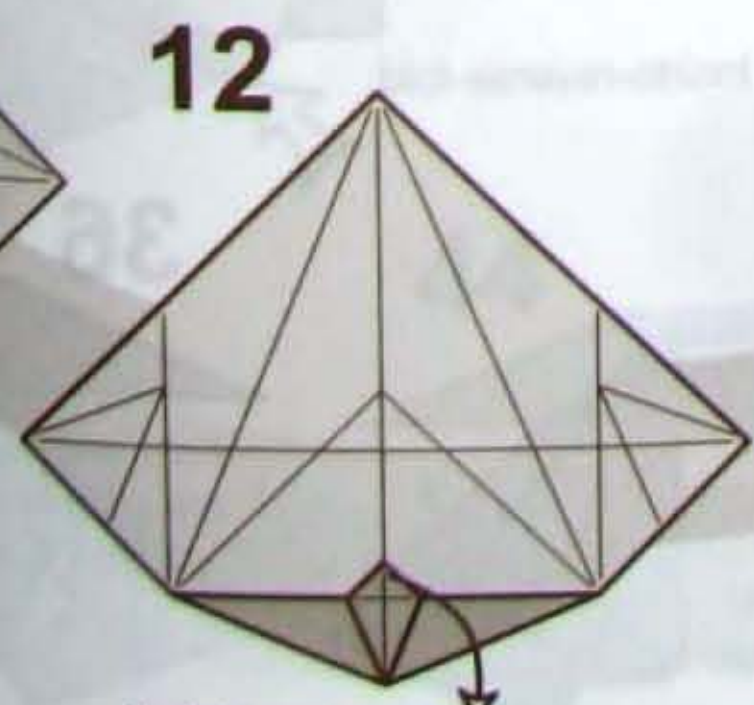

12

Unfold to step 9.

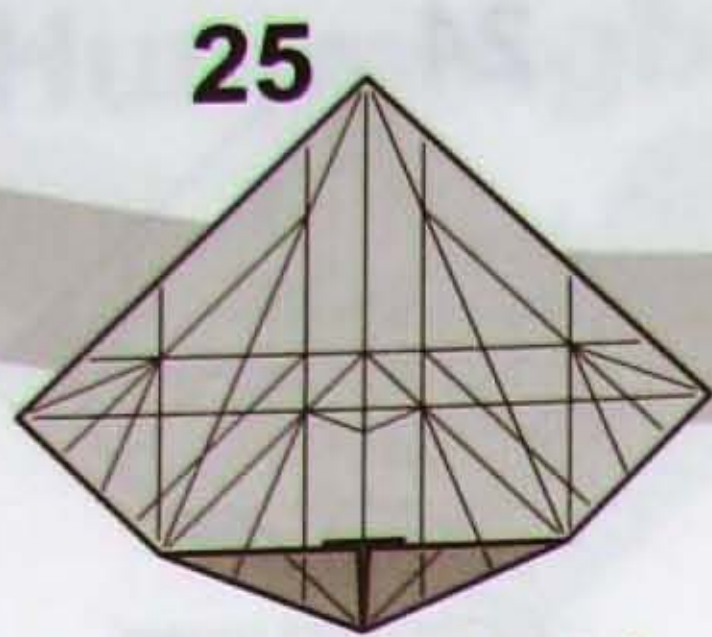

25
Precrasing is now finished.
Rotate 90 degrees.

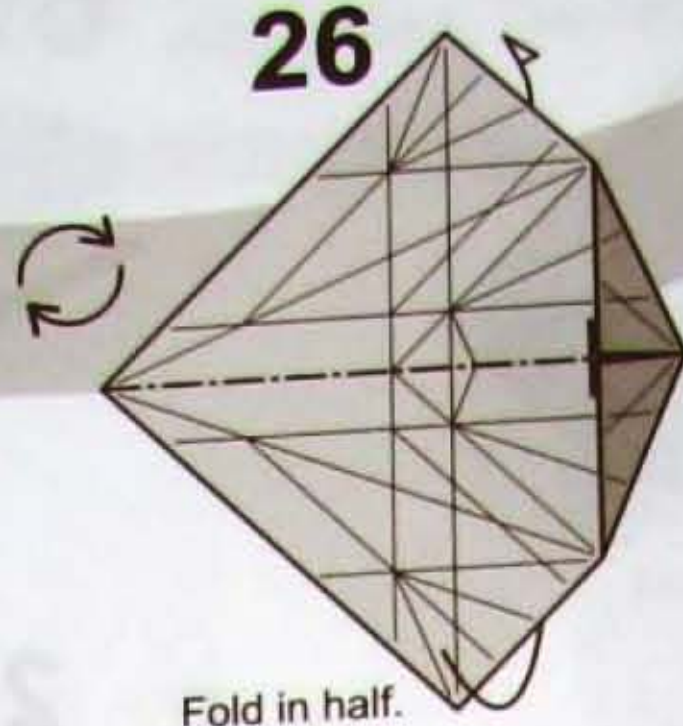

26
Fold in half.

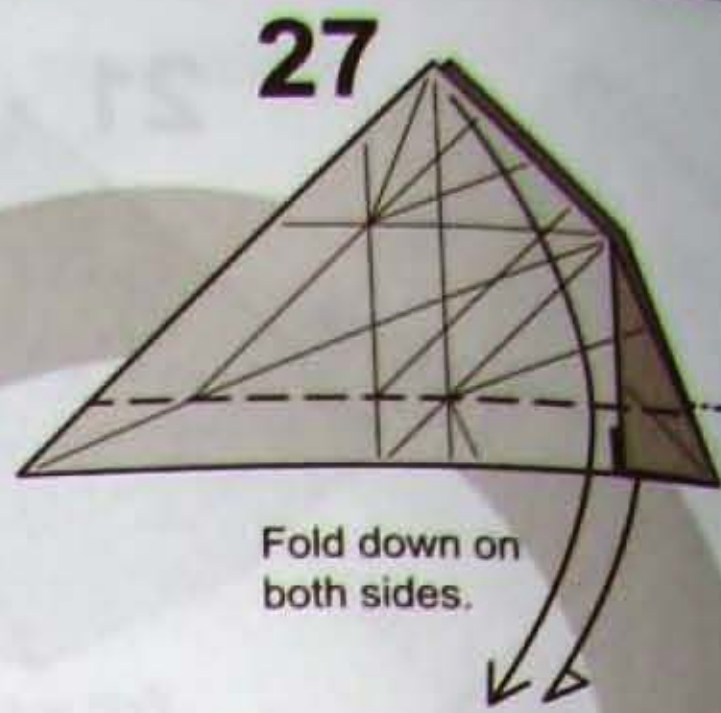

27
Fold down on
both sides.

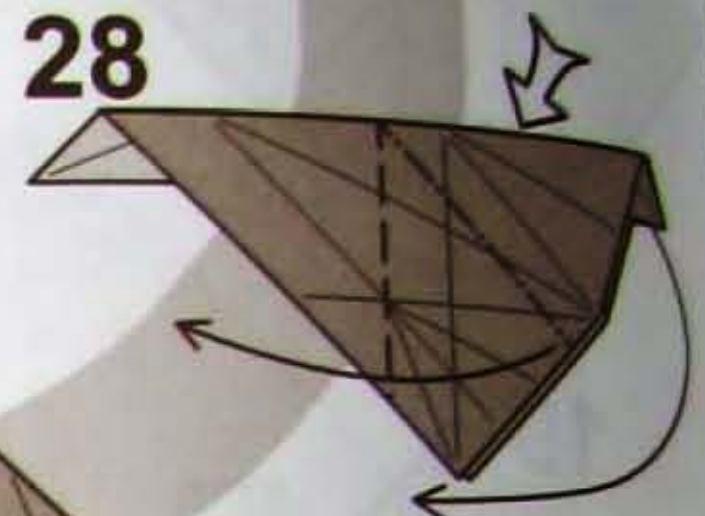

28
Squash-fold. Place your finger
just before the bottom layer.

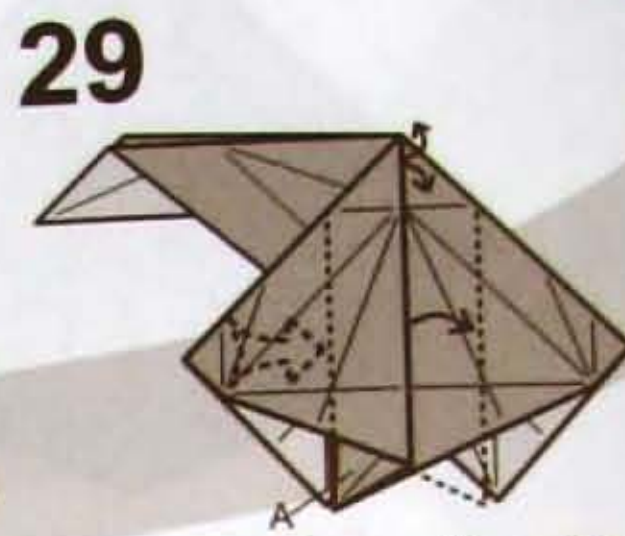

29
Note the position of flap A.
Release an edge from the
pocket.

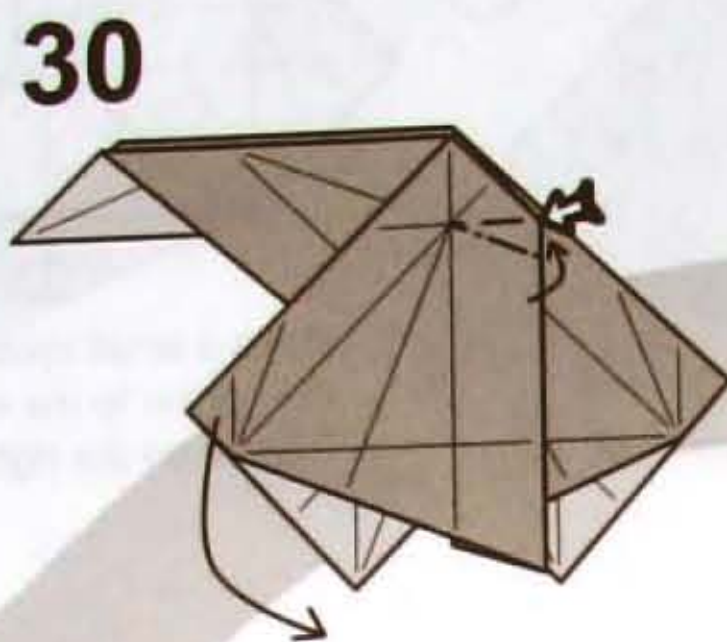

30
Outside-crimp-fold the edge on
existing creases. The paper will
not lie flat.

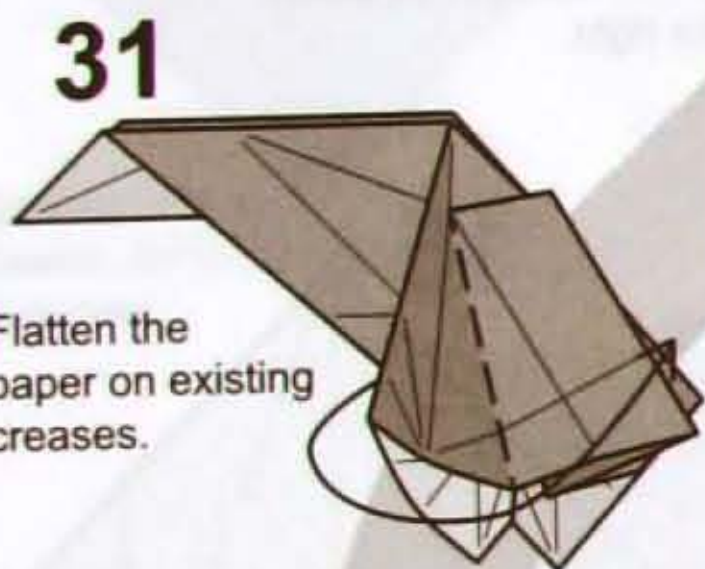

31
Flatten the
paper on existing
creases.

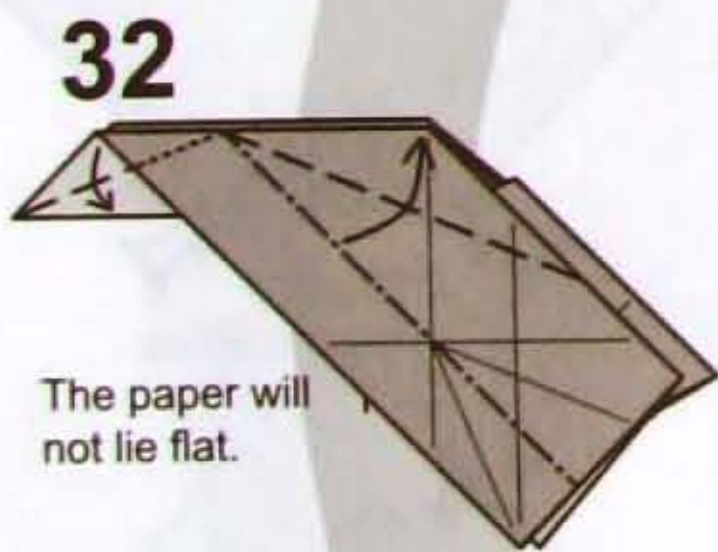

32
The paper will
not lie flat.

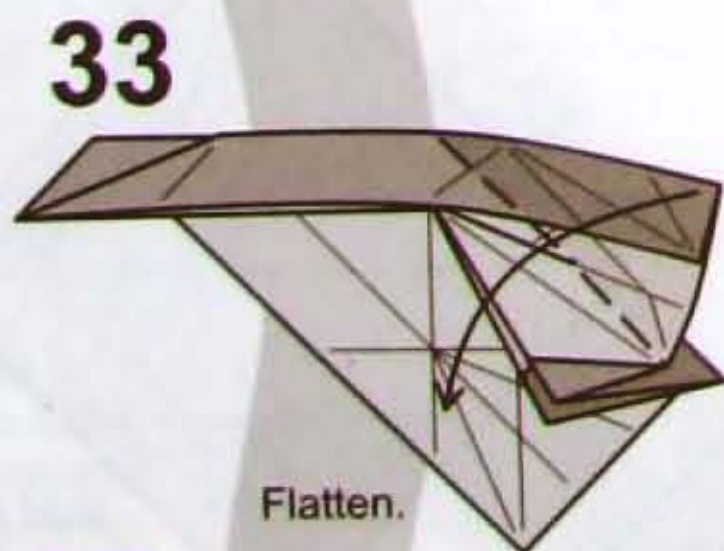

33
Flatten.



34
Repeat steps
32-33 behind.

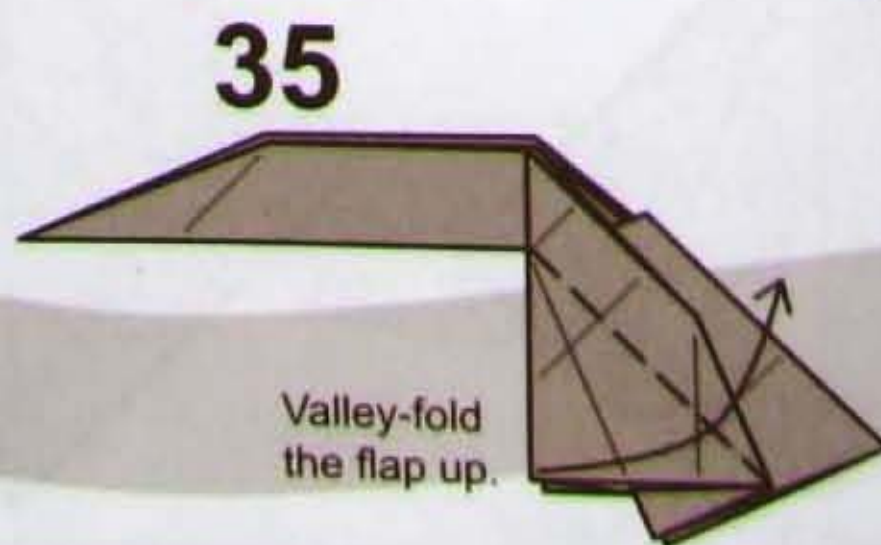

35
Valley-fold
the flap up.

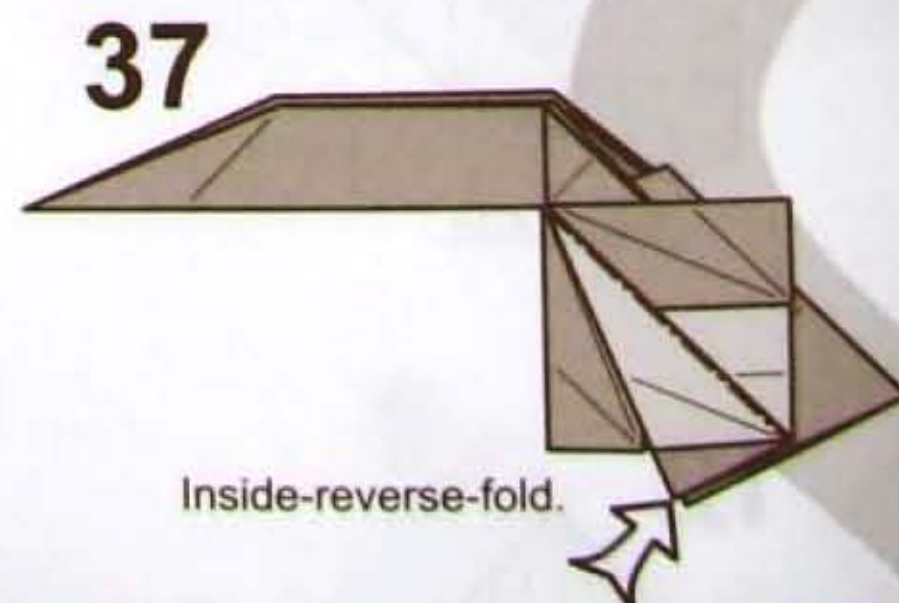

36
Inside-reverse-fold.

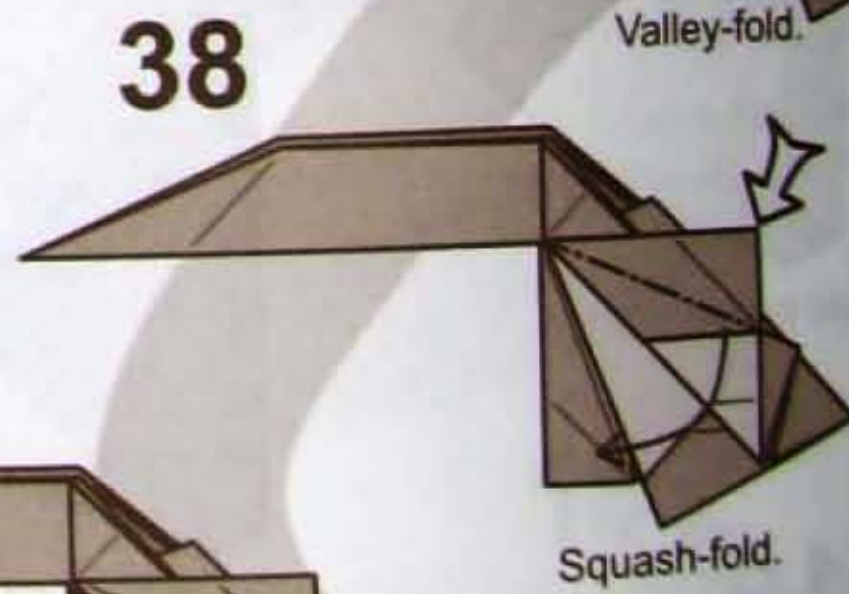

37
Squash-fold.

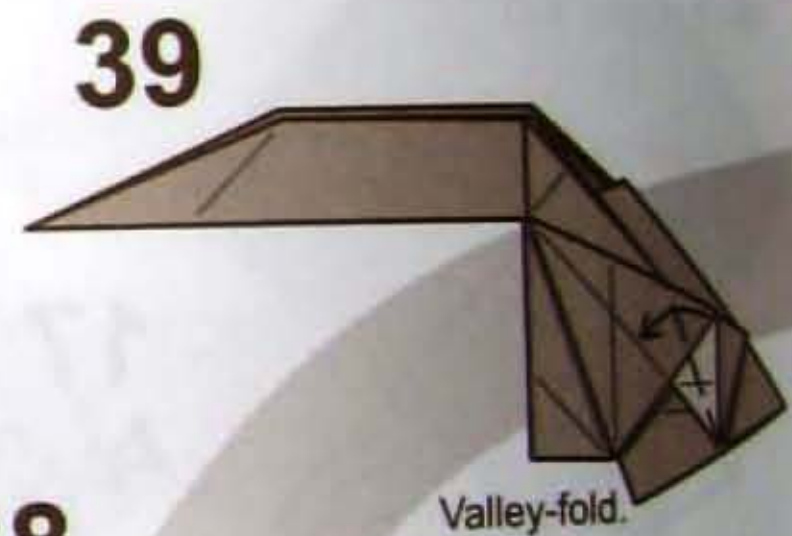

38
Valley-fold.



39
Squash-fold.

50

Fold
half

49

Fold behind and
unfold making it
as narrow as po

40

Fold
rele
pap

42

43

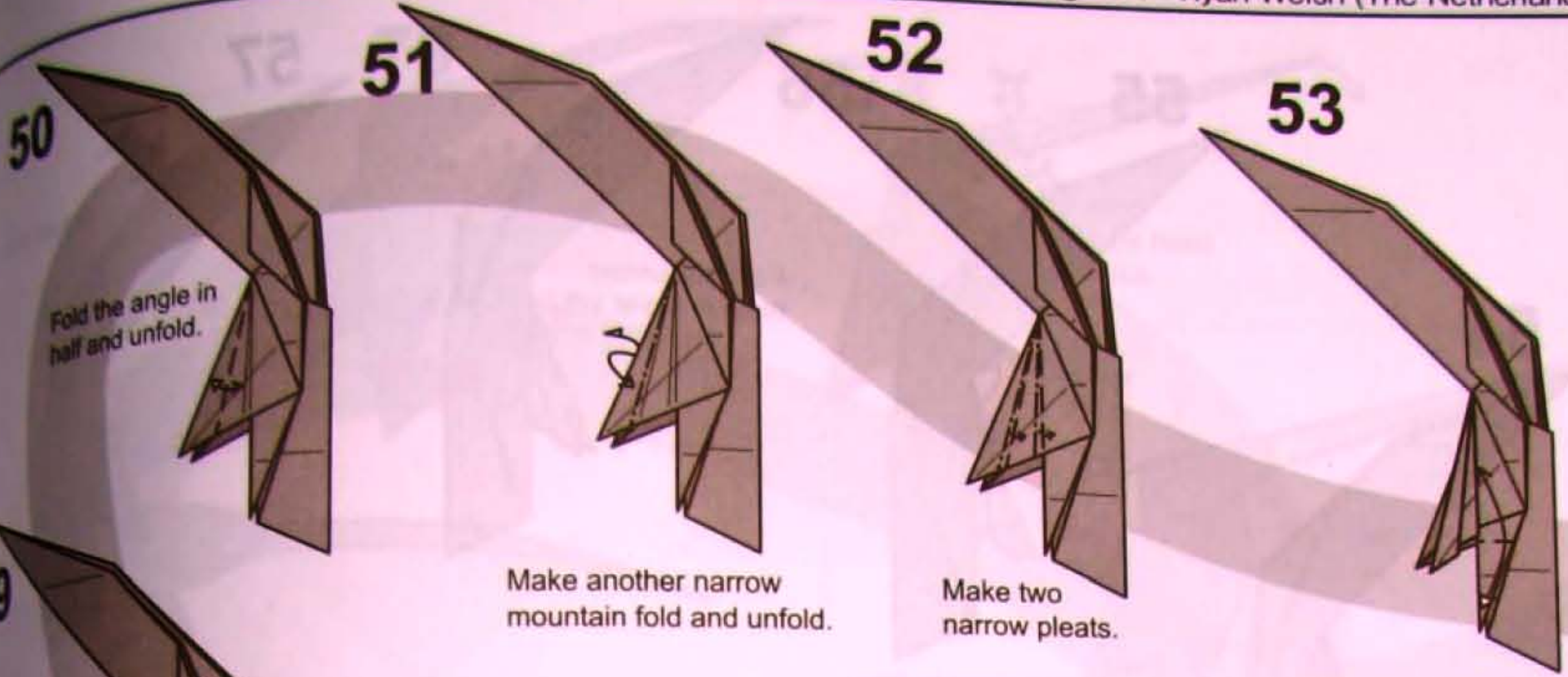

50

Fold the angle in half and unfold.

51

Make another narrow mountain fold and unfold.

52

Make two narrow pleats.

53

Fold and unfold the point as far as it will go, but perpendicular to the left edge.

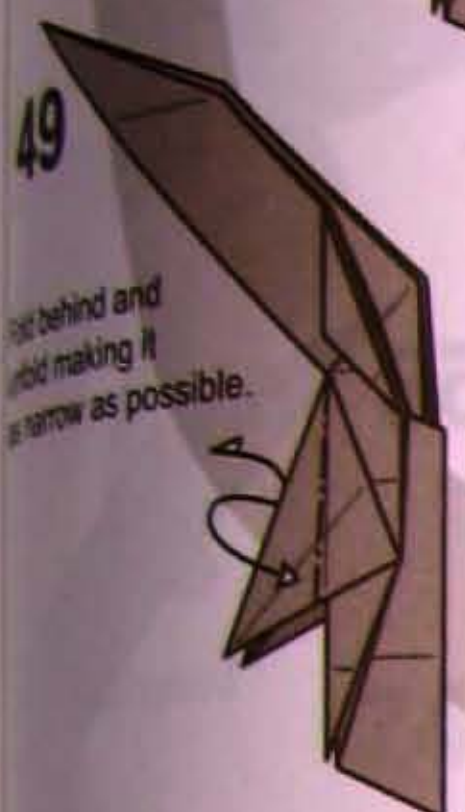

49

Slide behind and fold making it as narrow as possible.

48

Closed-sink the corner.

47

Crease the next layer.

46

Fold a corner. The crease is perpendicular to edge B. Also note where it starts.

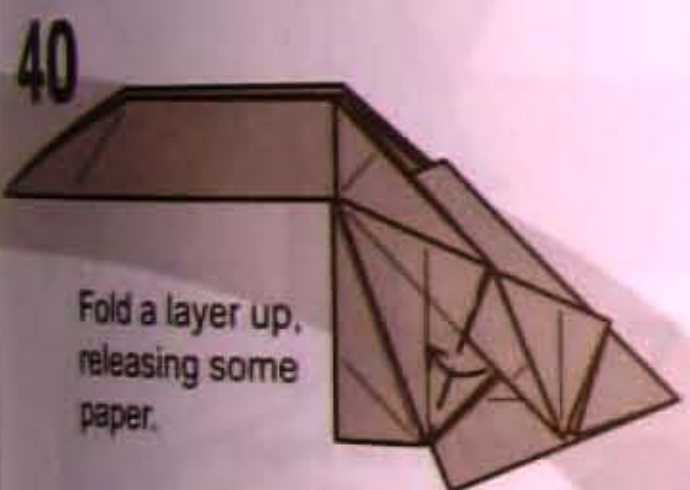

40

Fold a layer up, releasing some paper.

41

Fold down.

42

Reverse-fold.

43

Fold inside.

44

Reverse-fold again.

45

Repeat steps 35-44 behind. Then rotate the model.

Japão Burajirujin

www.japaoburajirujin.blogspot.com

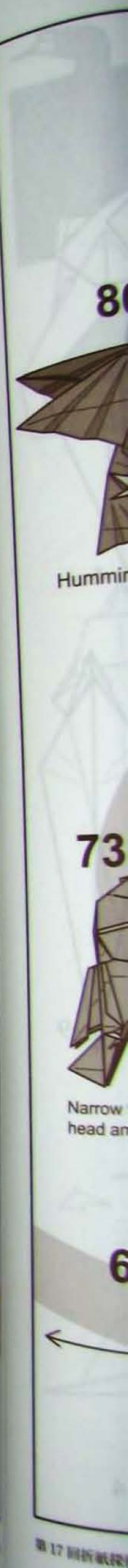
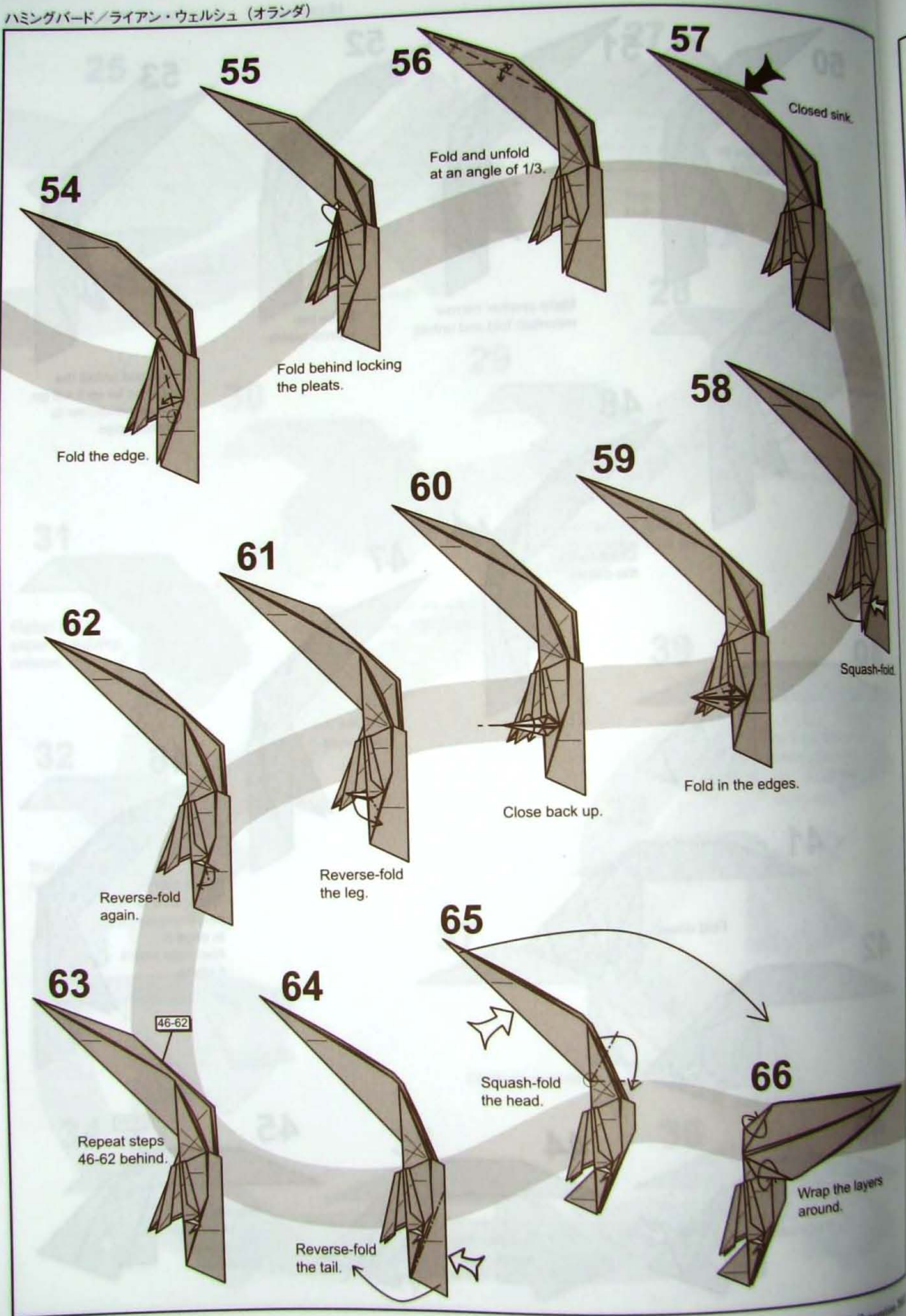

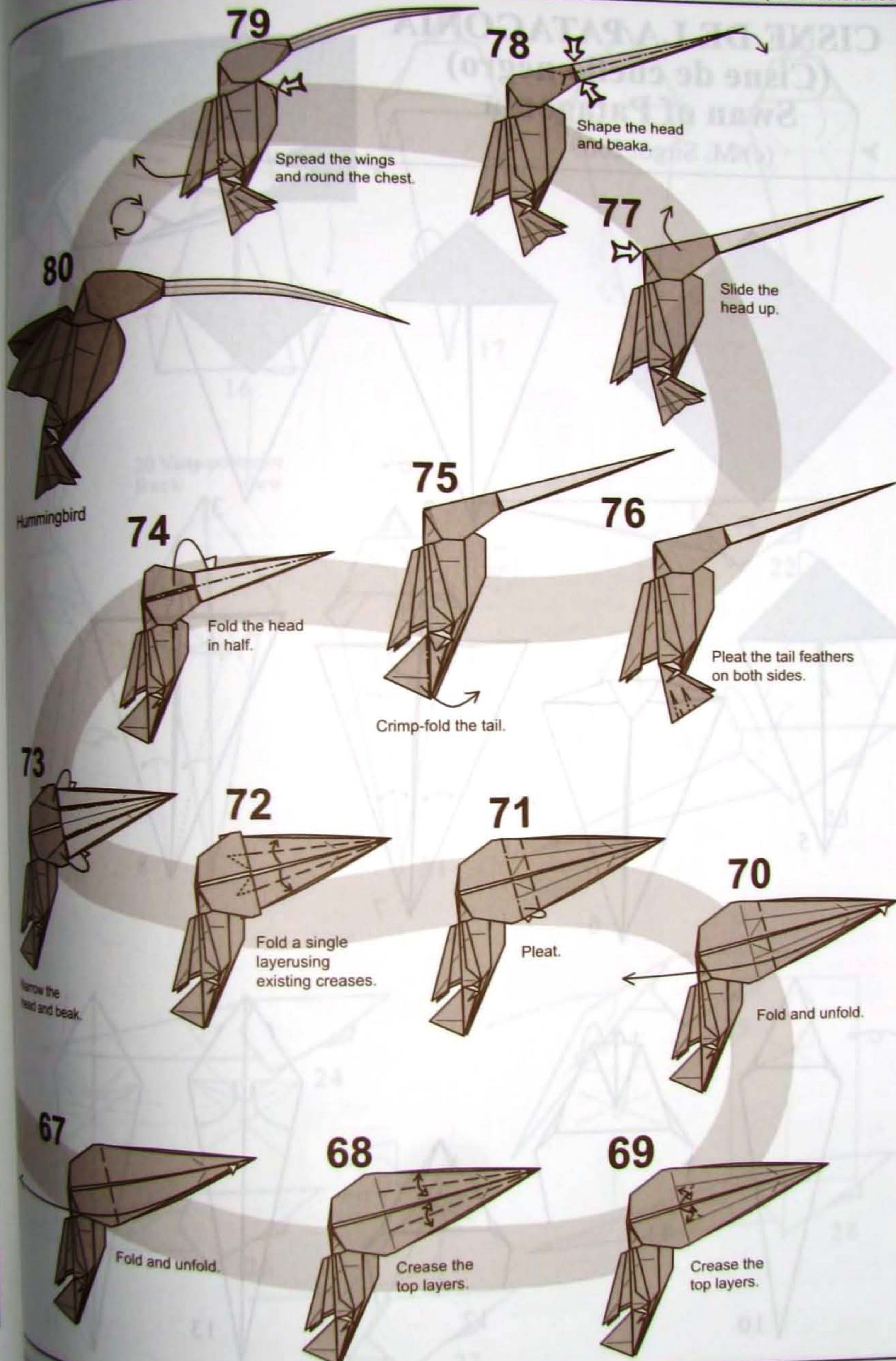

Hummingbird

sed sink.

Squash-fold.

the layers and.

CISNE DE LA PATAGONIA (Cisne de cuello negro) Swan of Patagonia

(c) M. Sirgo. 2009

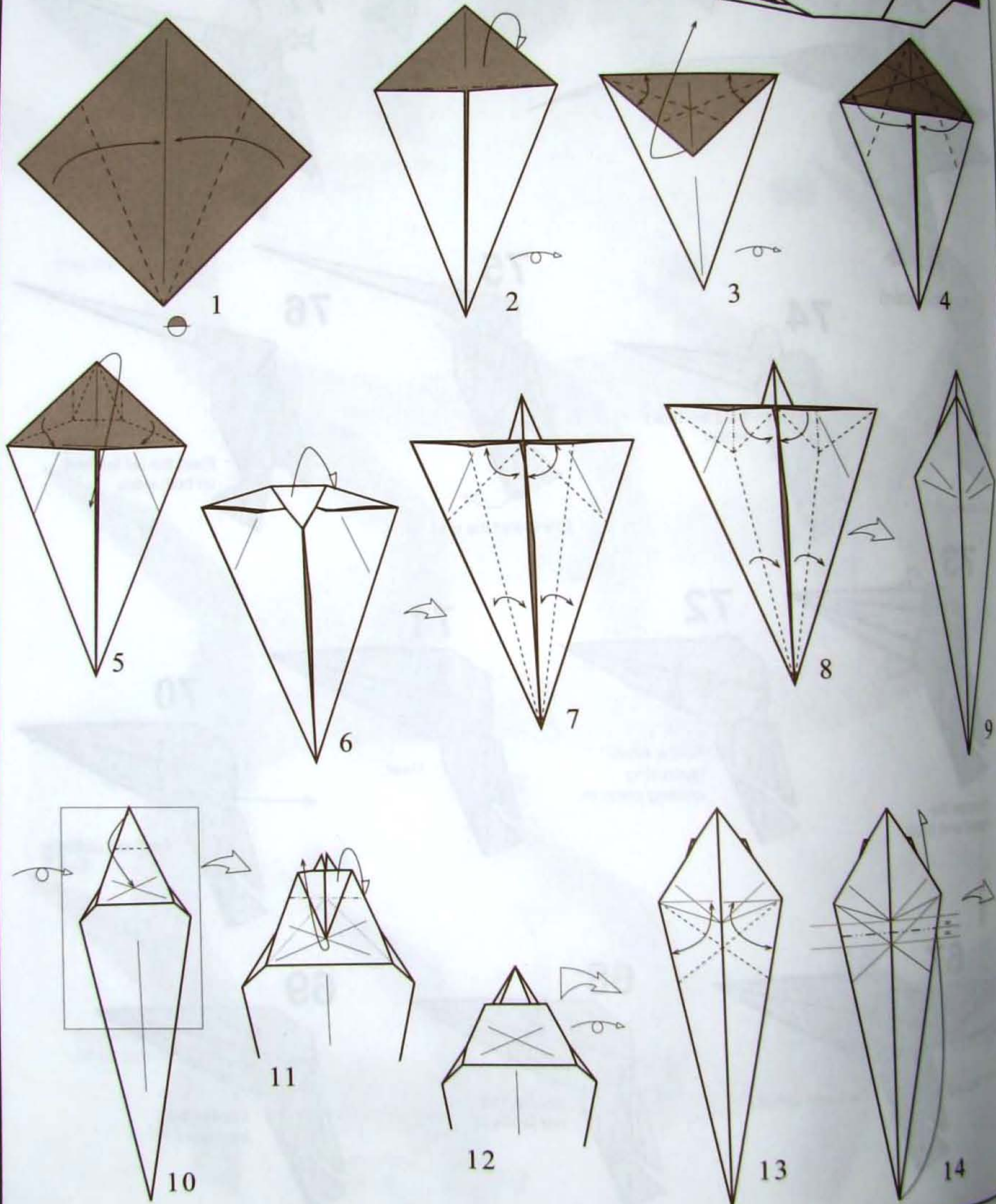
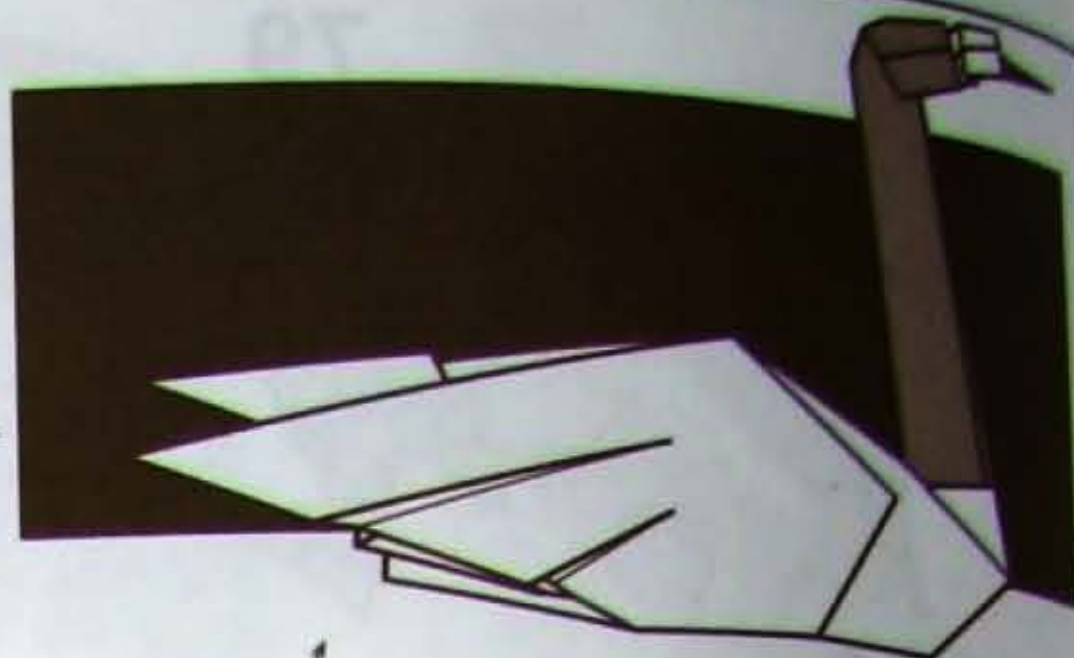

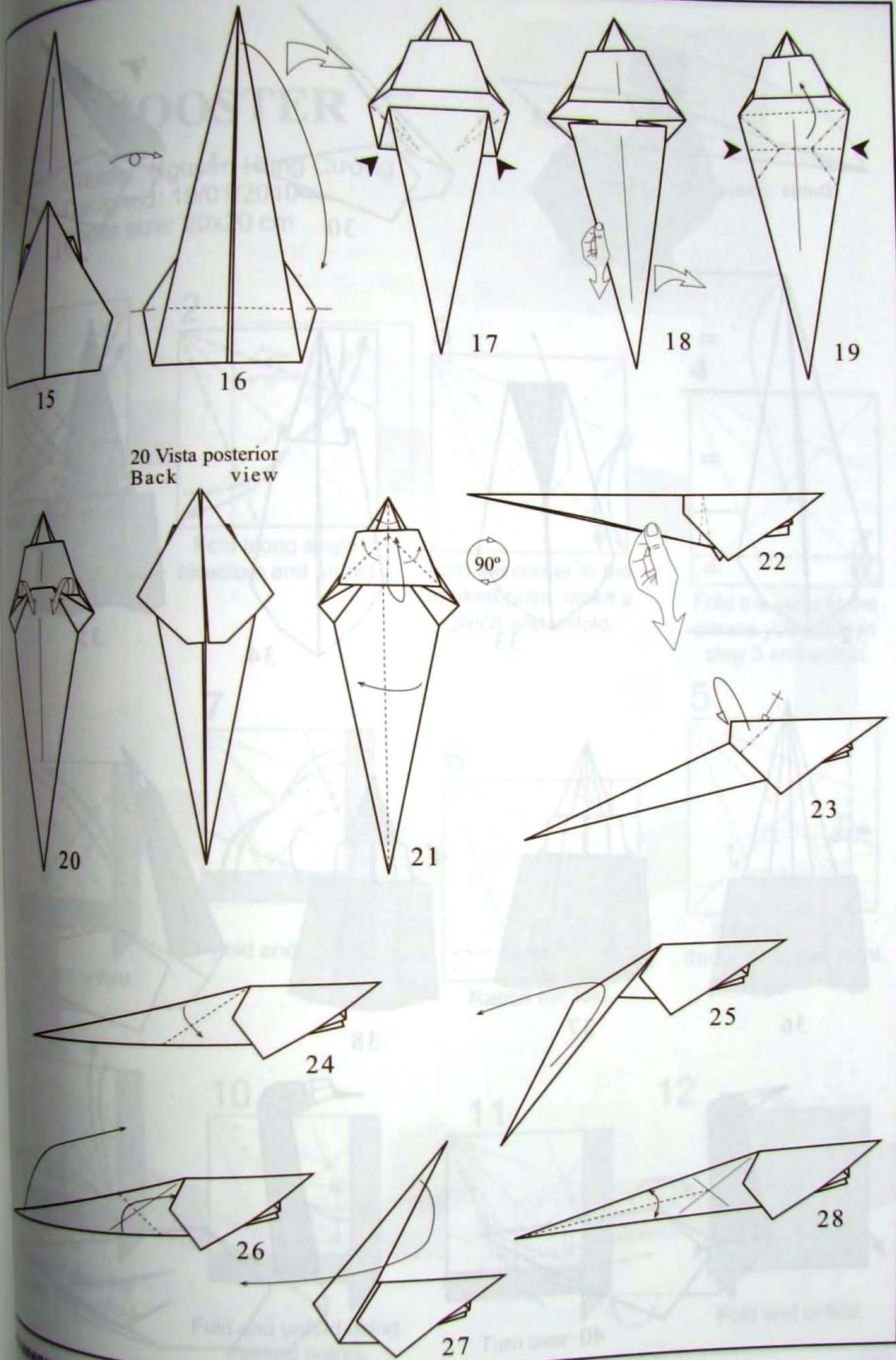

20 Vista posterior
Back view

90°

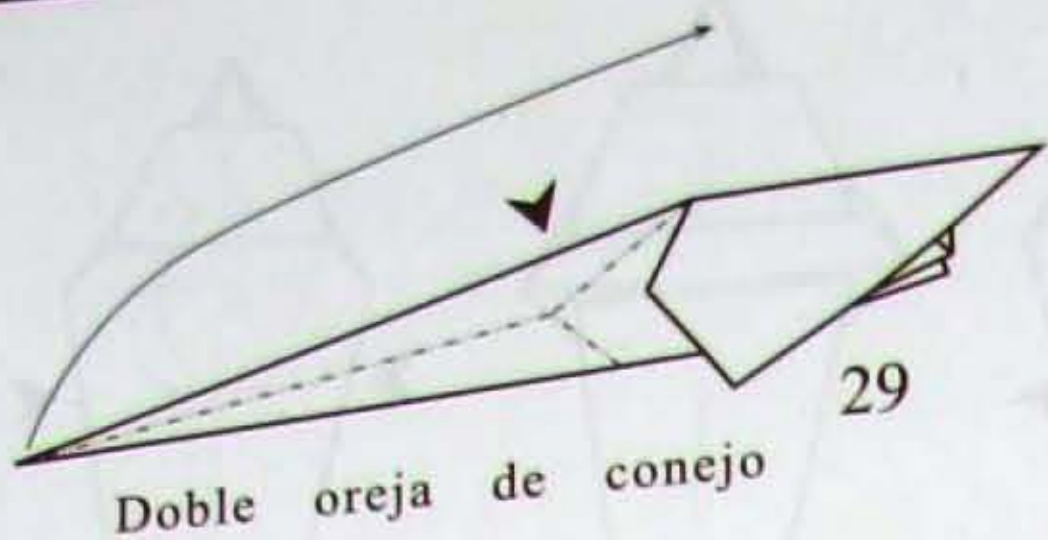

Doble oreja de conejo

29

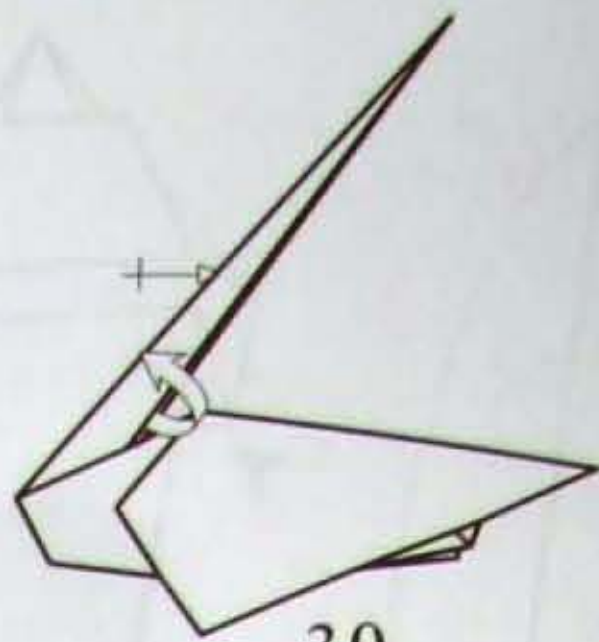

30



31

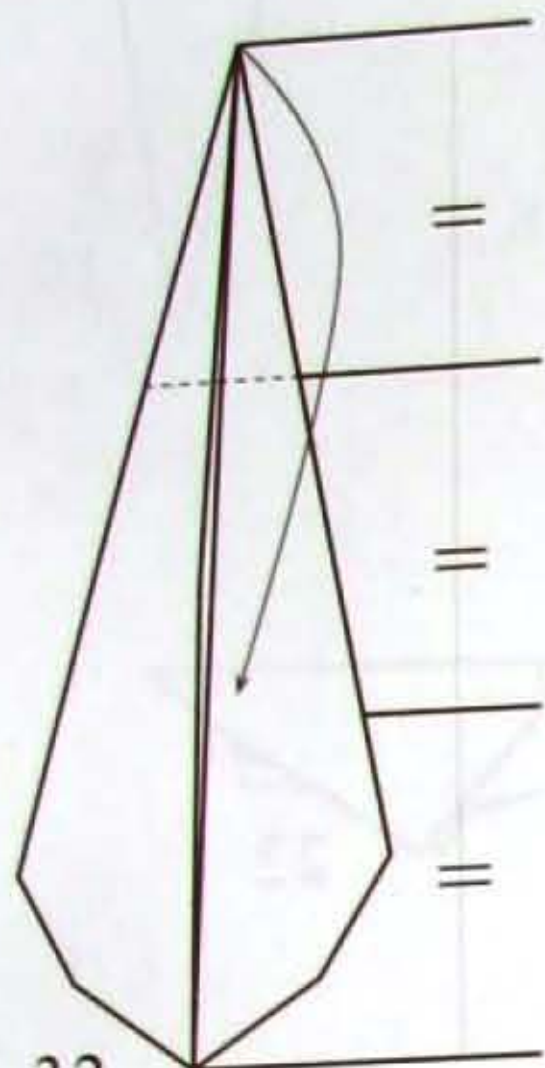

32

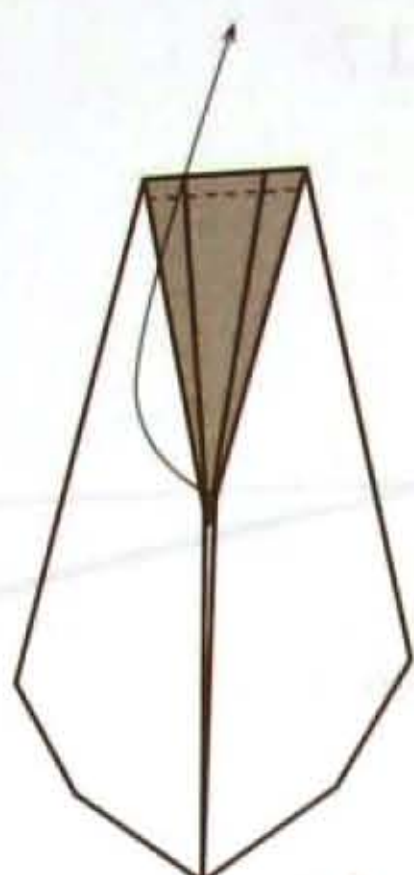

33

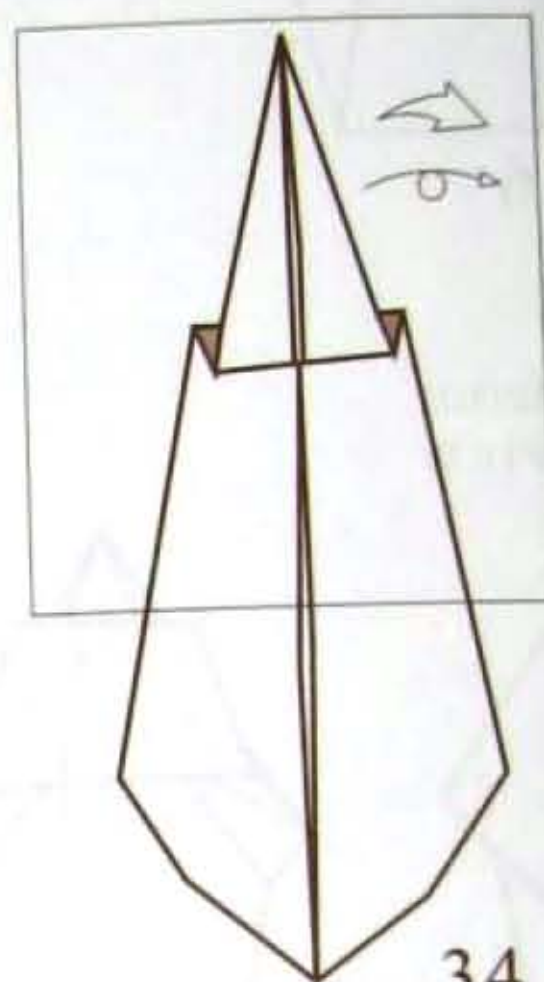

34

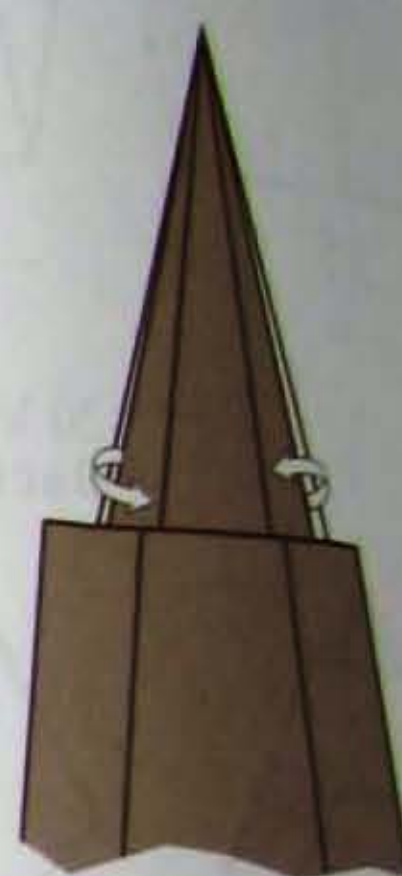

35

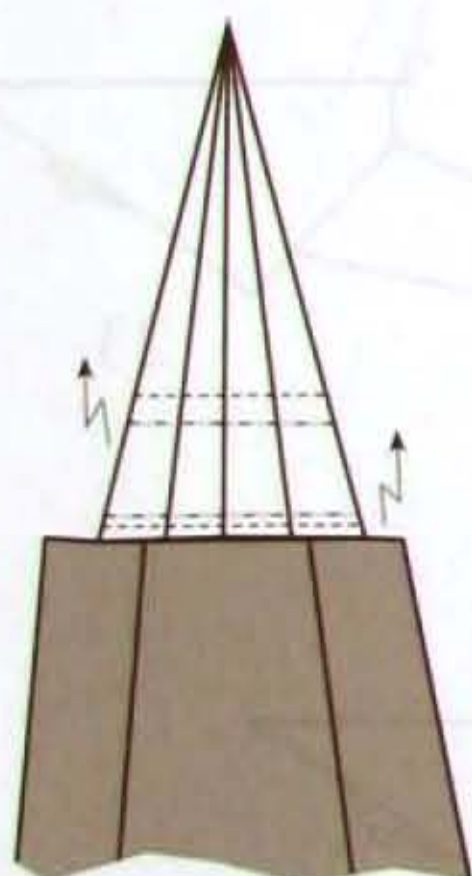

36



37

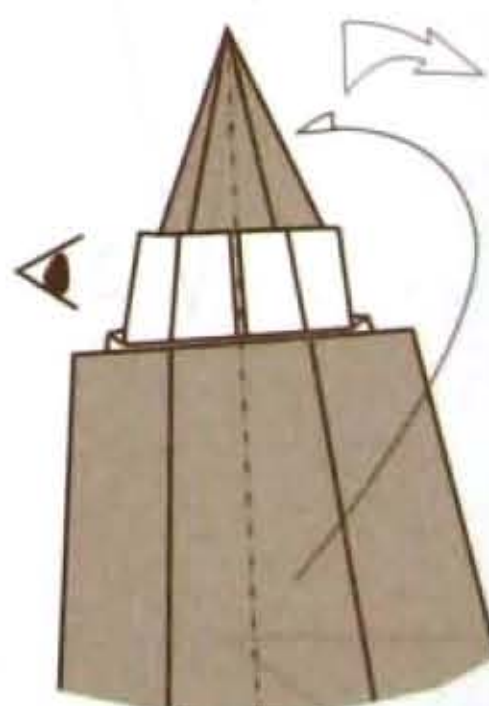

38

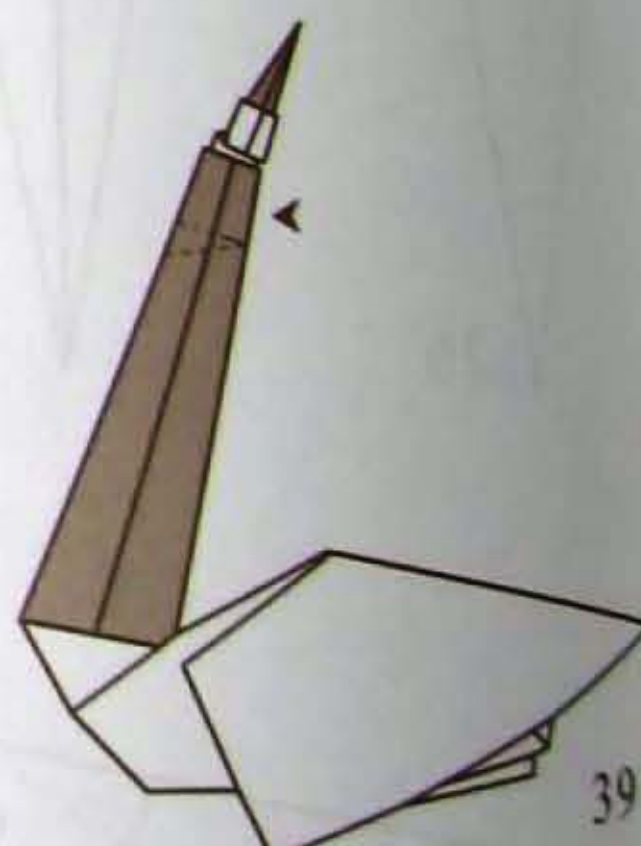

39

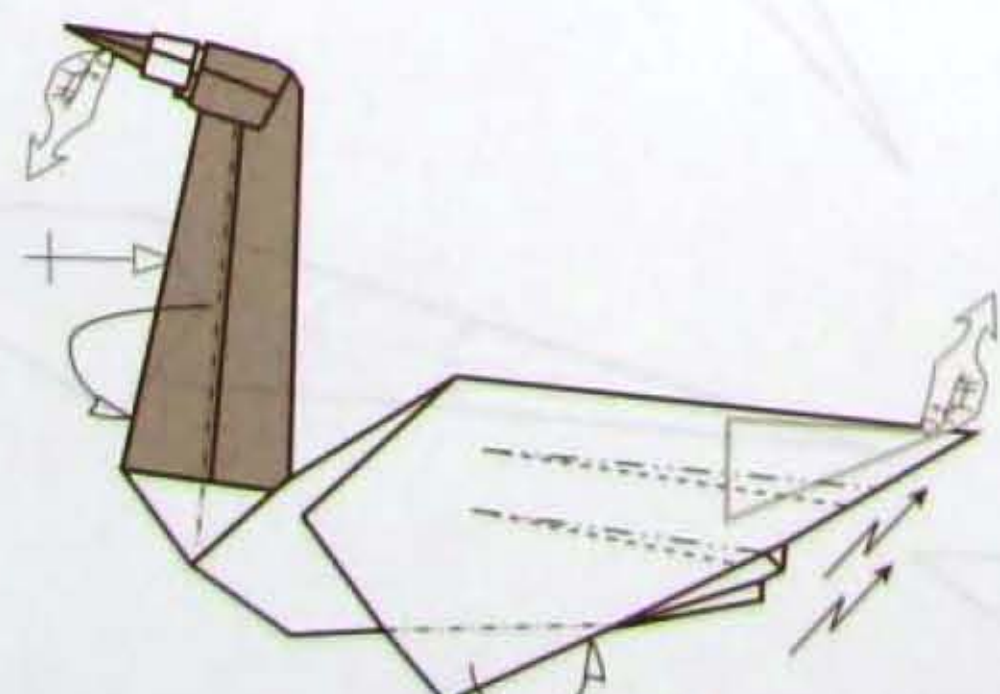

40

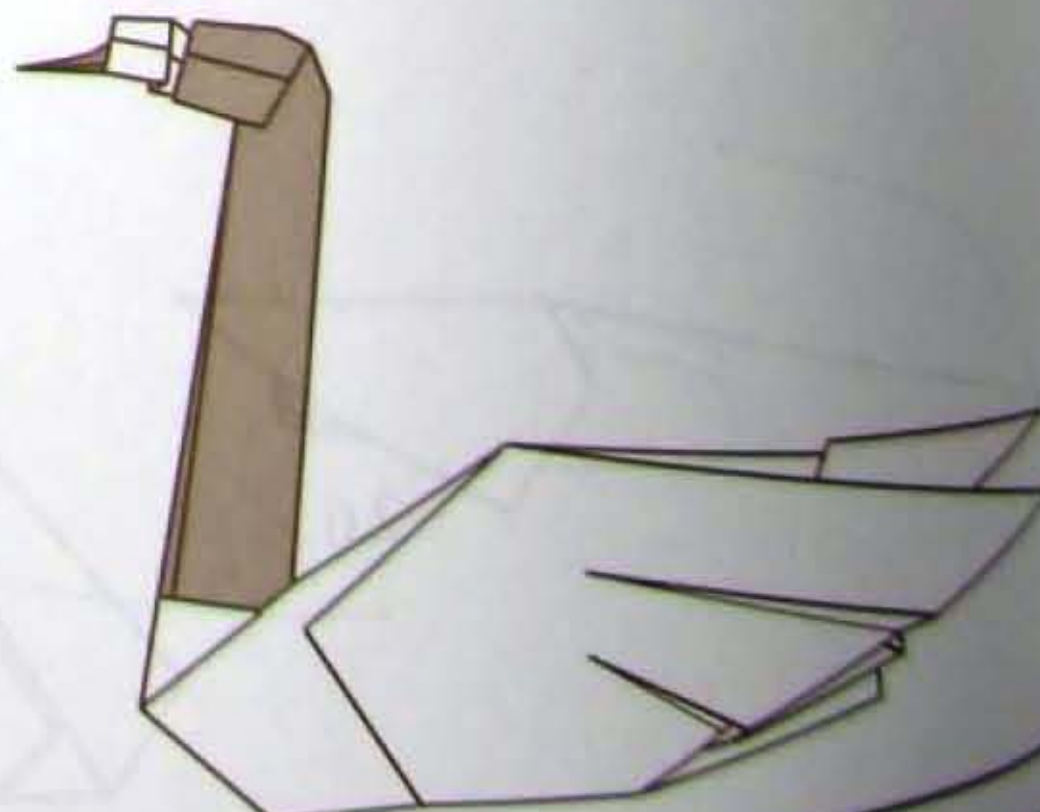

ROOSTER

Creator: Nguyễn Hùng Cường
 Designed: 19/01/2010
 Paper size: 20x20 cm

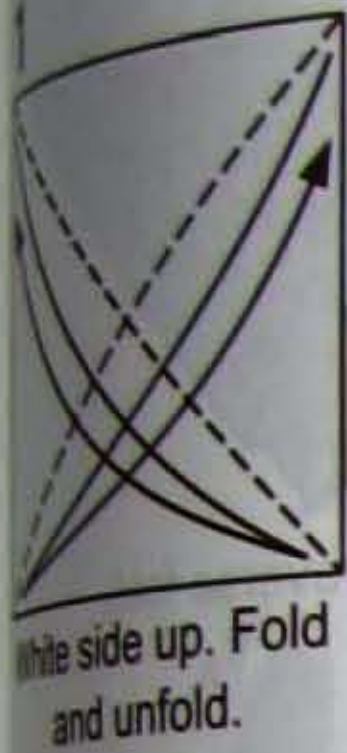

White side up. Fold and unfold.

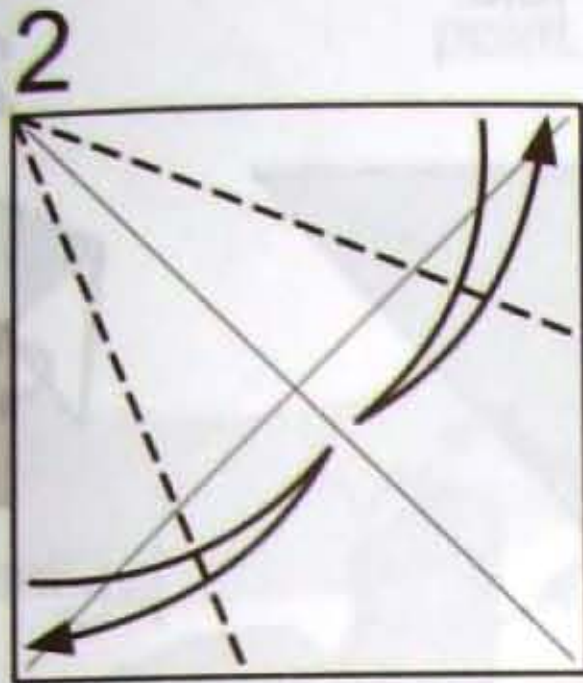

Fold along angle bisectors and unfold.

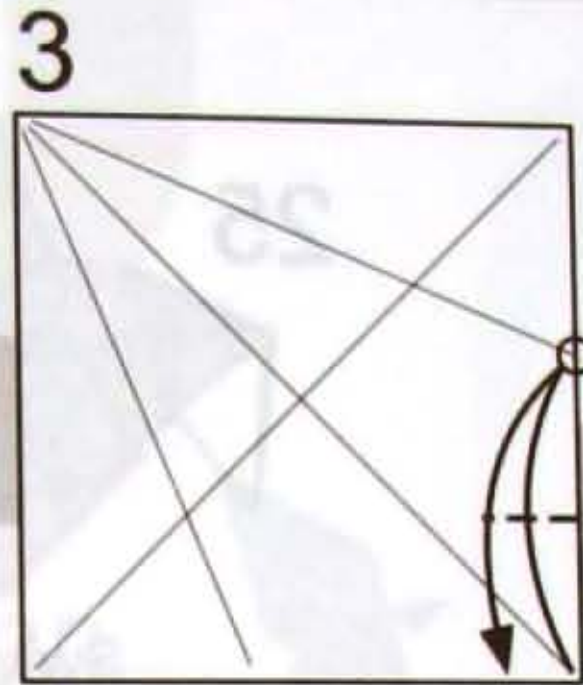

Fold the corner to the marked point, make a pinch and unfold.

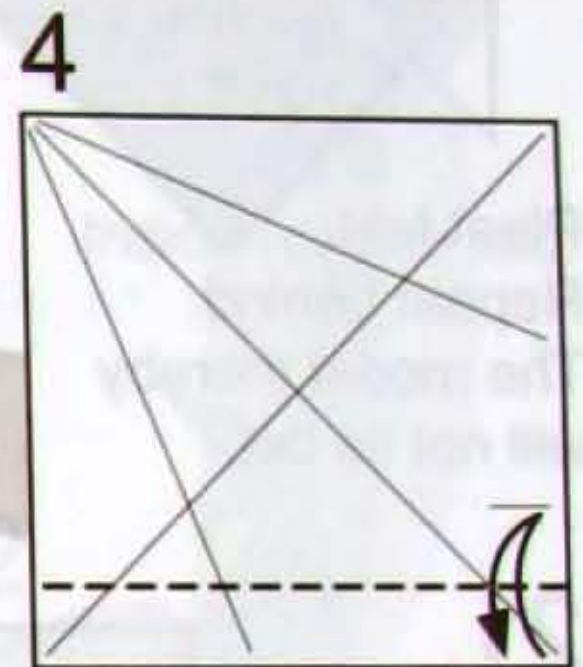

Fold the edge to the crease you made in step 3 and unfold.

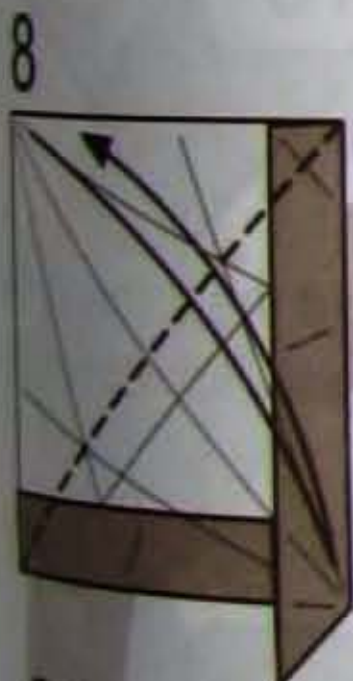

Fold and unfold.

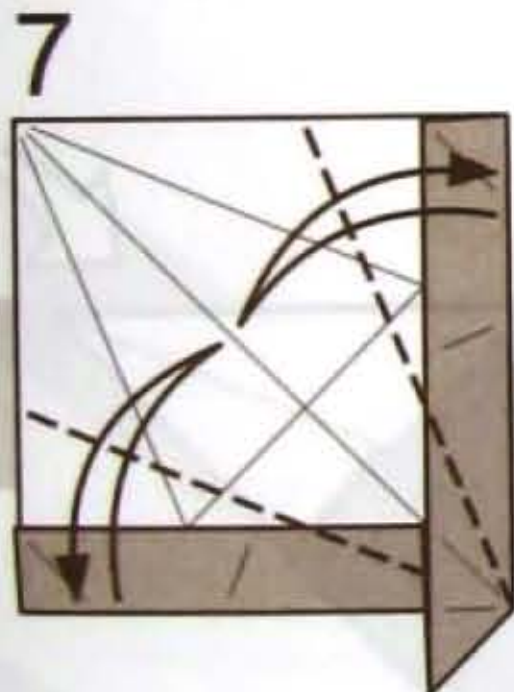

Fold and unfold.

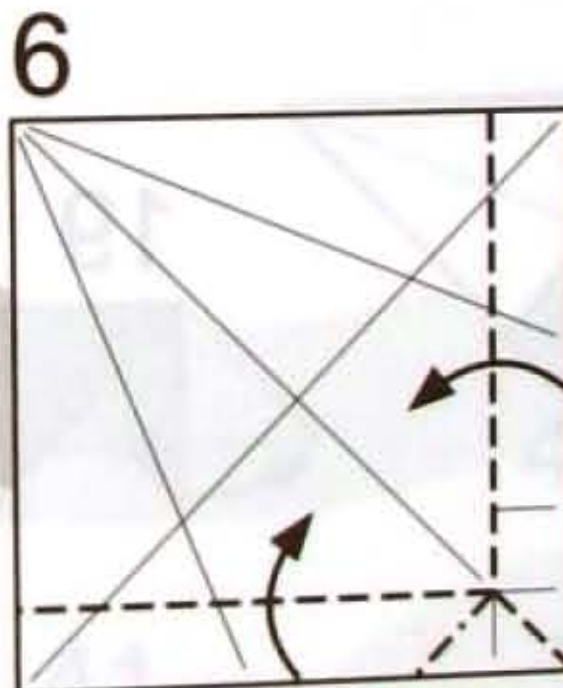

Rabbit ear fold.

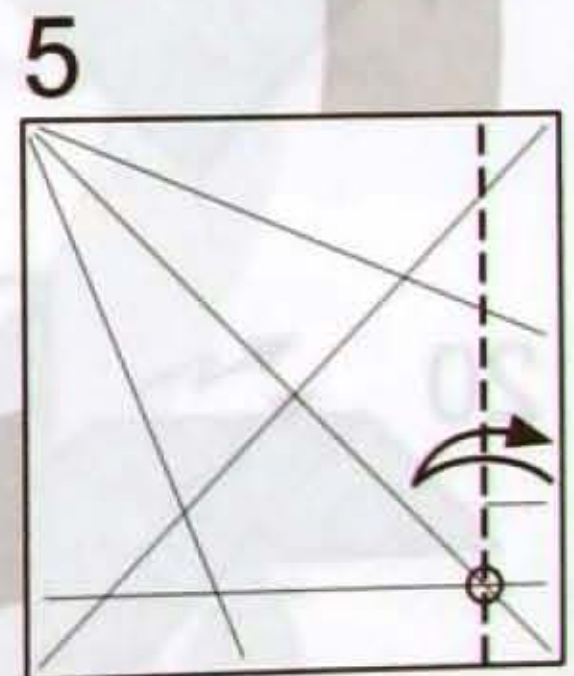

Fold and unfold through marked point.



Fold and align the edges, then unfold.

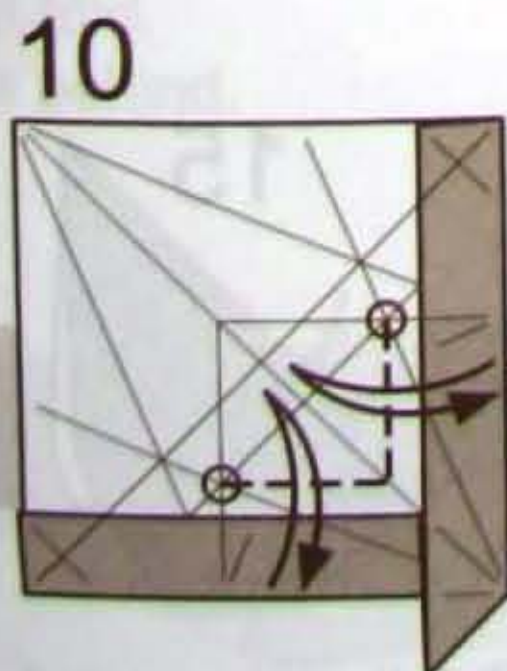

Fold and unfold using marked points.

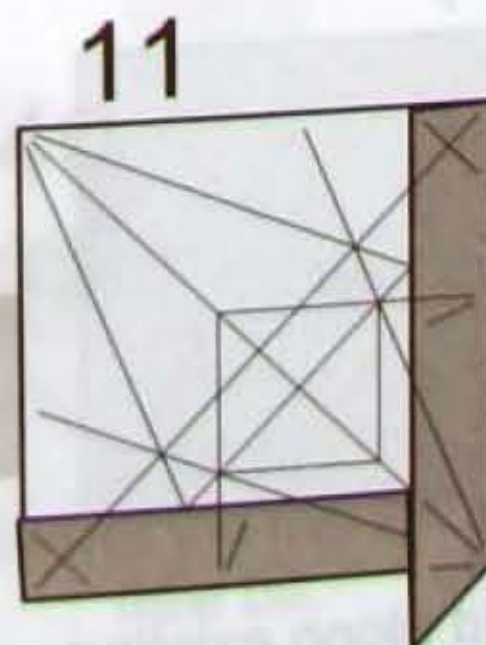

Turn over.

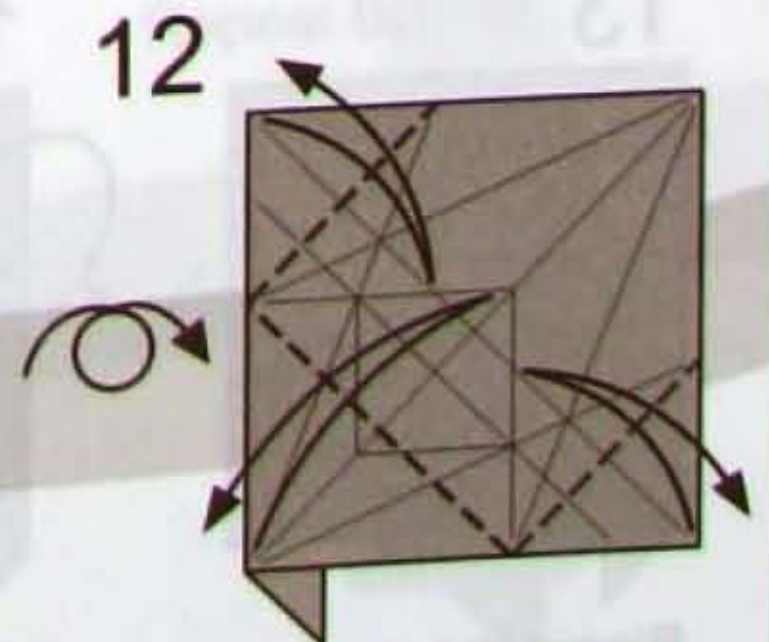

Fold and unfold.

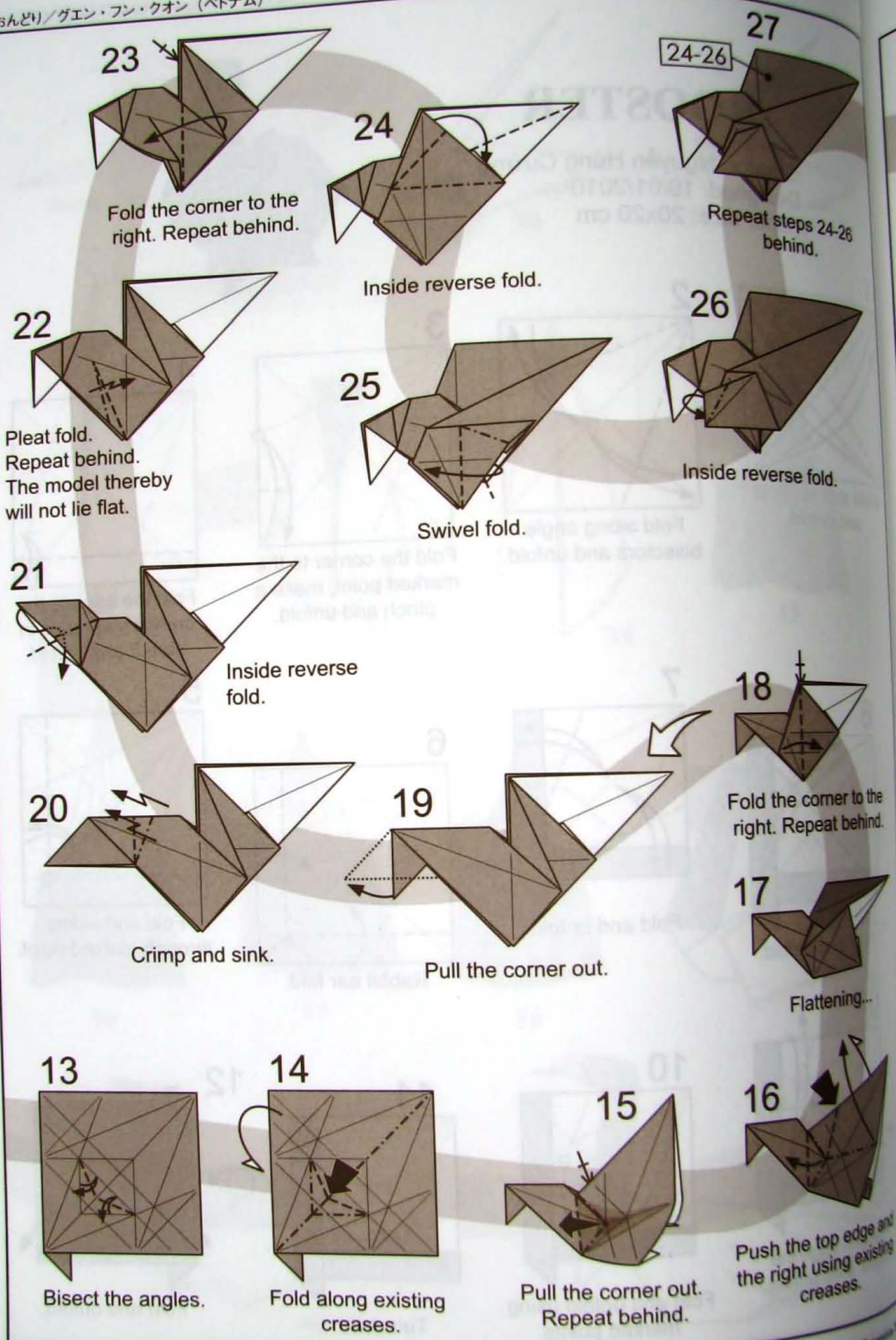

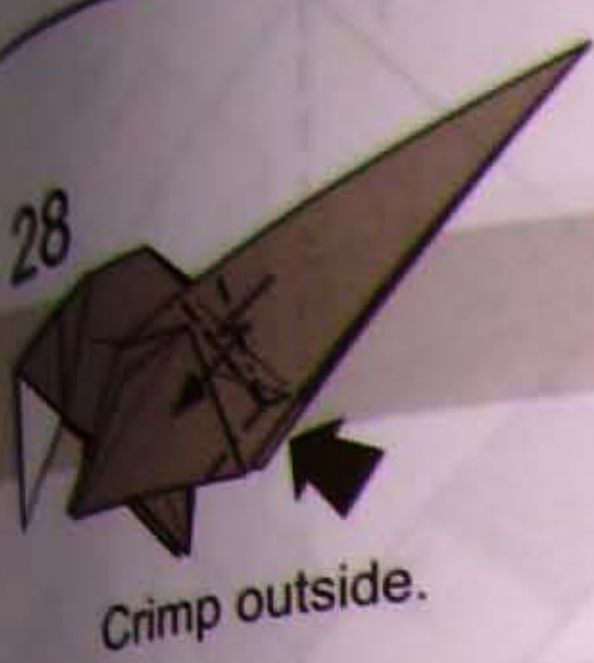

28 Crimp outside.



29 Fold the corner down. There is no reference point.

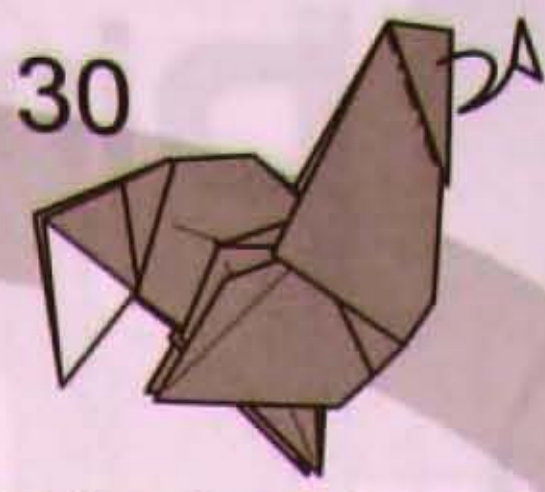

30 Fold and unfold. Open to step 29.

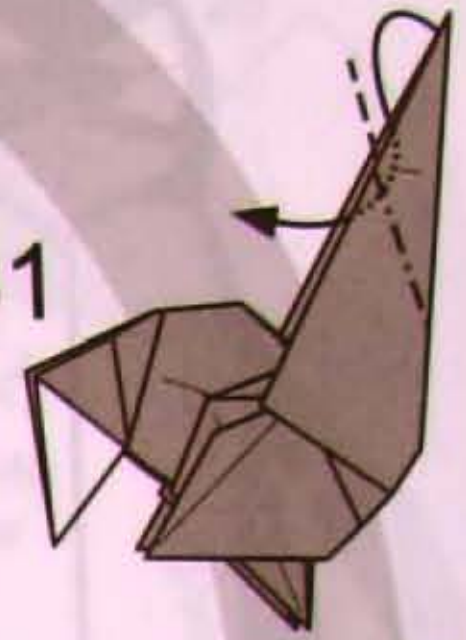

31 Inside reverse fold.



35 Crimp.

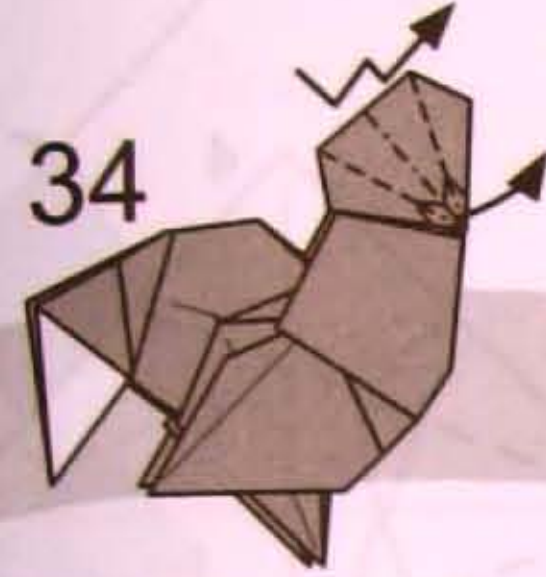

34 Fold the corner out.



33 Open.



32 Fold the corner down.

Japão Burajirujin

www.japaoburajirujin.blogspot.com



36



37 Pleat fold. Repeat behind.



41

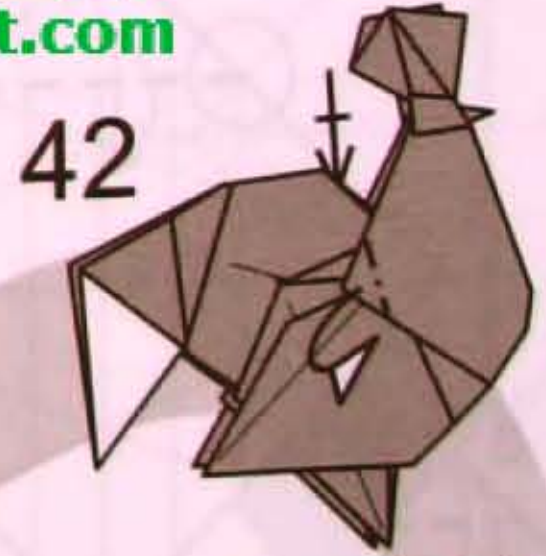

42 Mountain fold. Repeat behind.



38 Pleat fold. Repeat behind.



39 Inside reverse fold the middle flap.



40 Swivel the flaps a little bit.

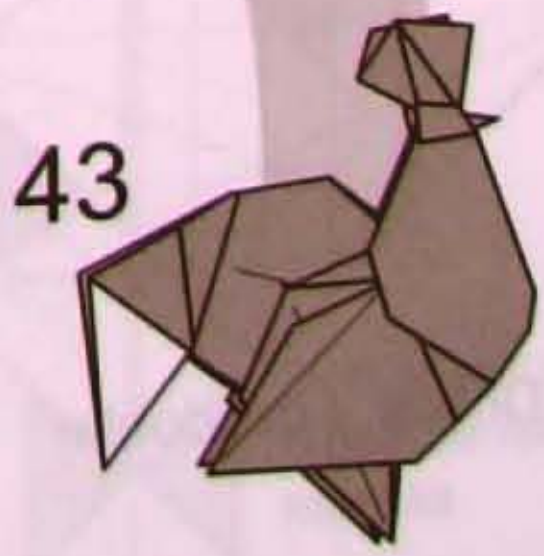

43 Model finished.

Pingüino



DIFICULTAD:



© Fernando Gilgado (Spain) 2010
elfernan3@hotmail.com
gilgado.pajarita.org

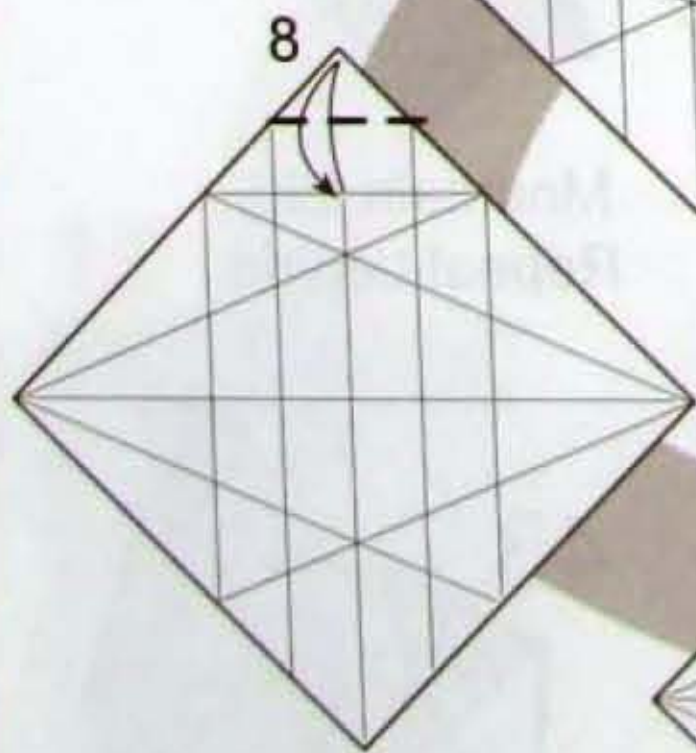
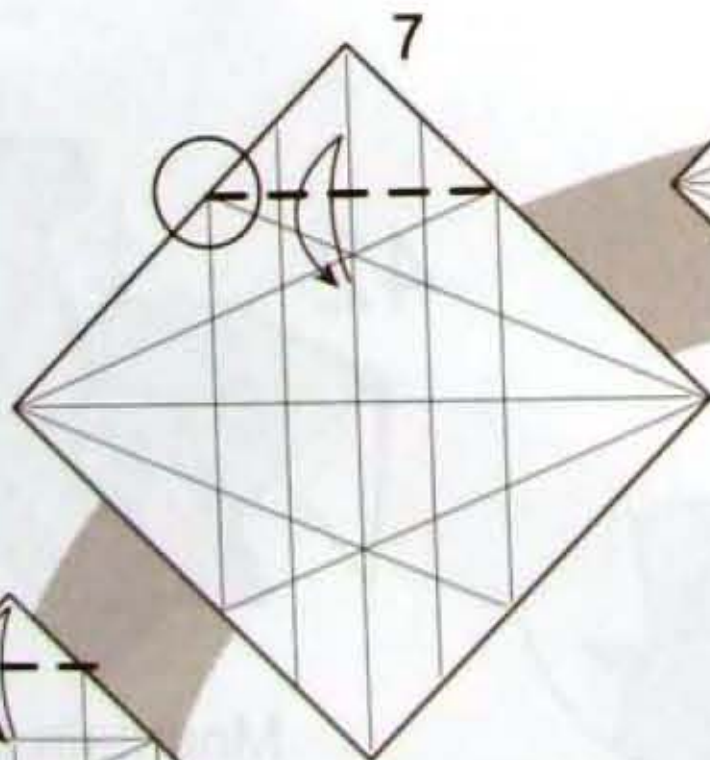
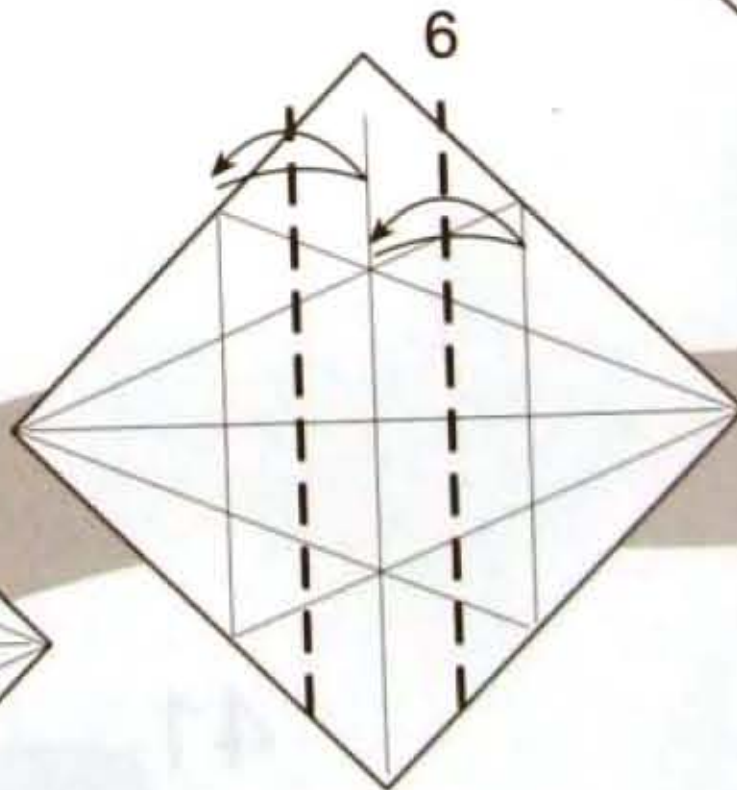
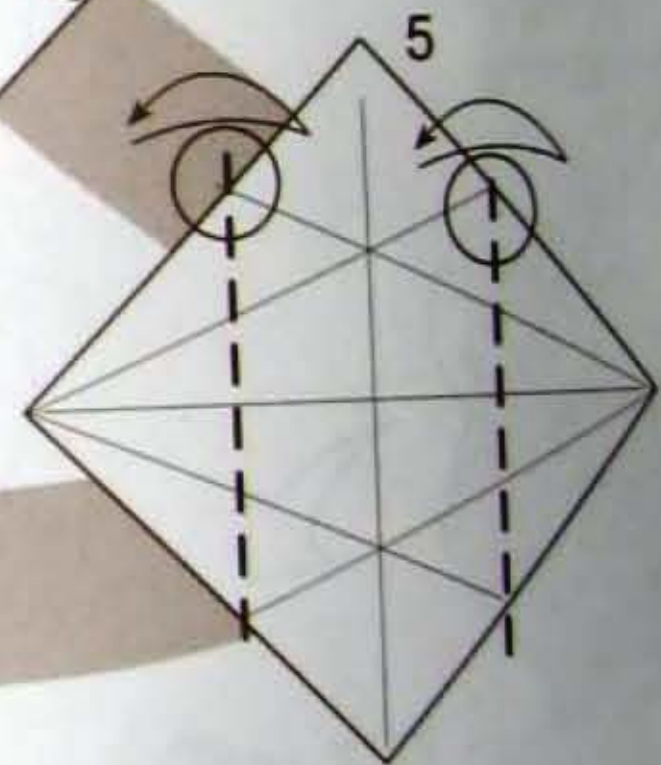
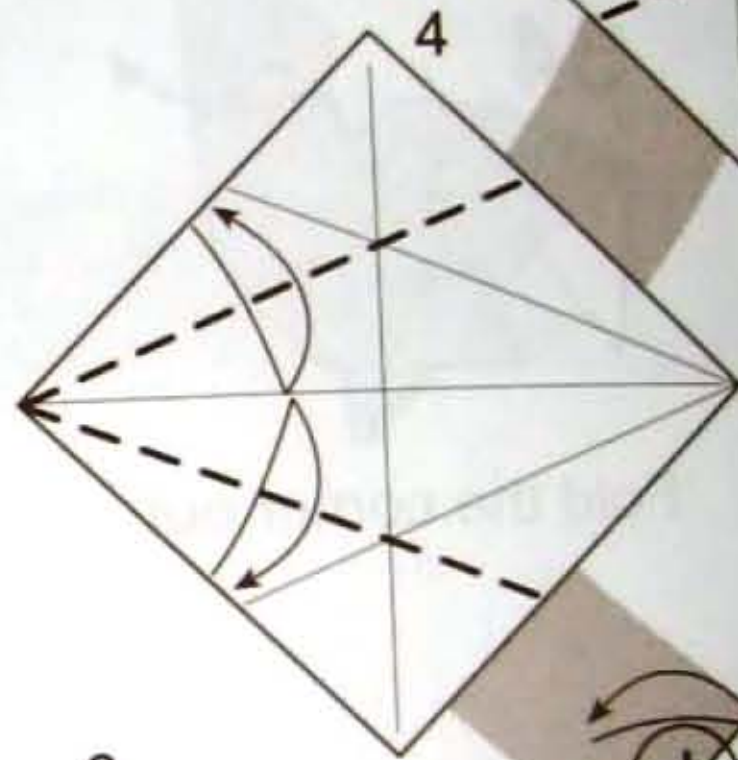
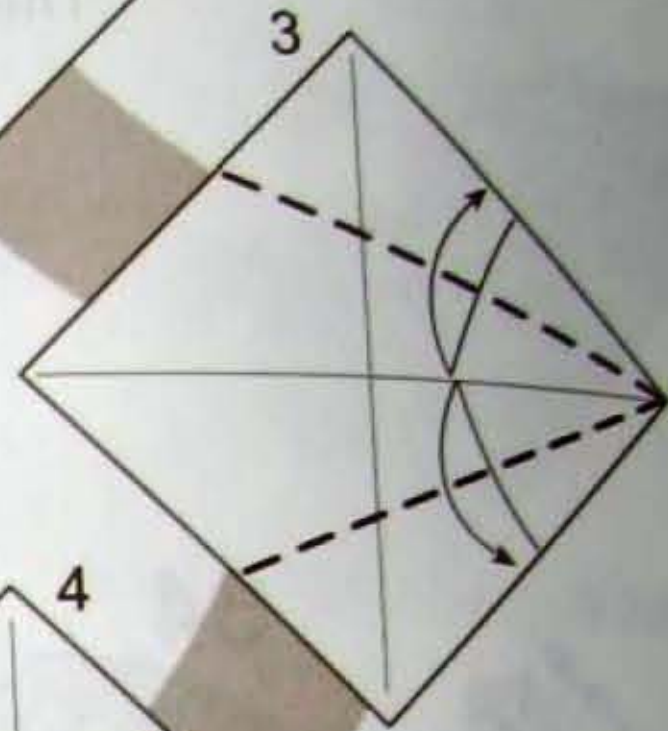
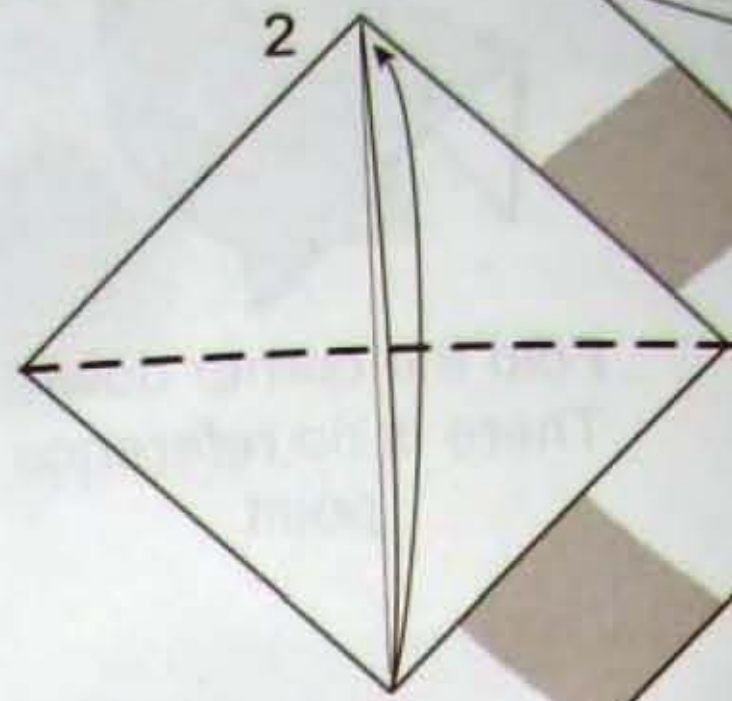

Doblar y desdoblar

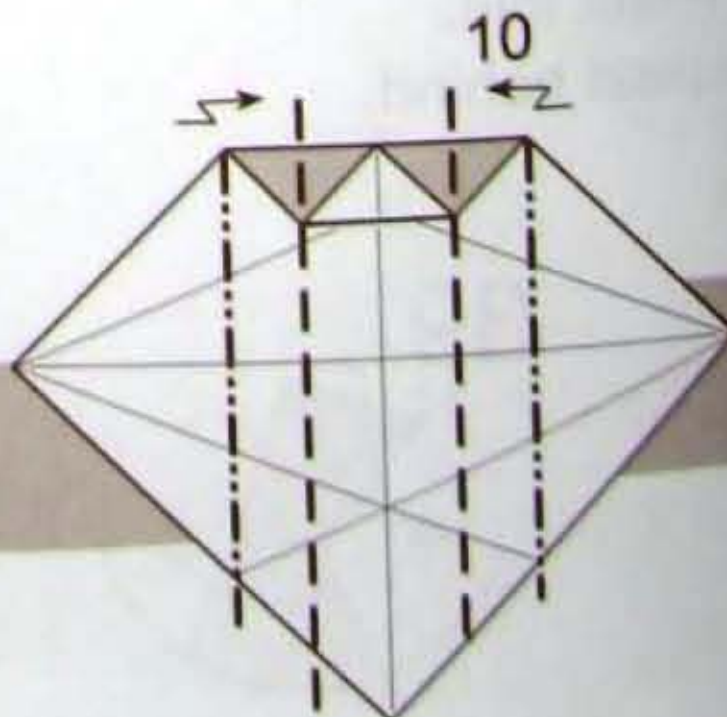
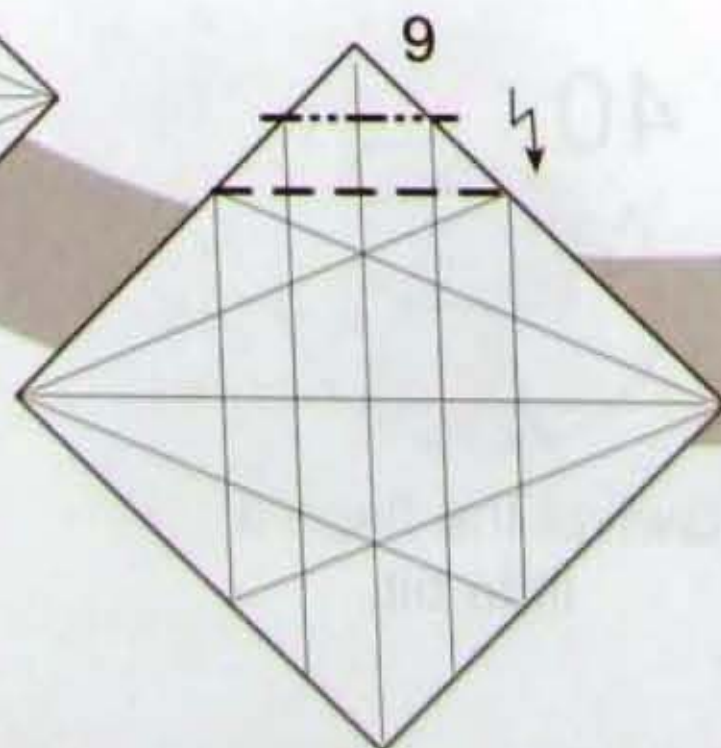

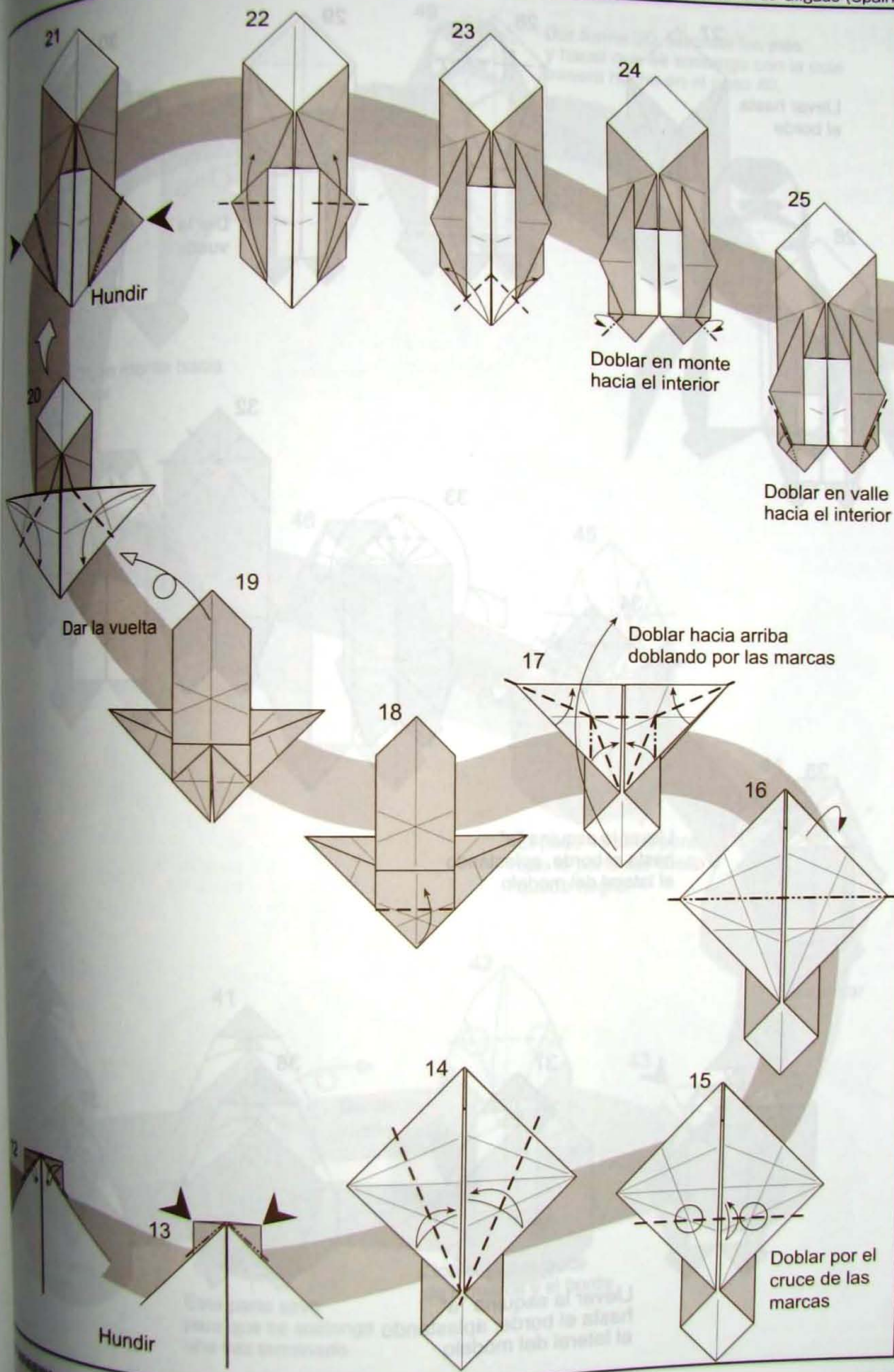

Hundir

Dar la vuelta

Doblar en monte hacia el interior

Doblar en valle hacia el interior

Doblar hacia arriba doblando por las marcas

Doblar por el cruce de las marcas

Hundir

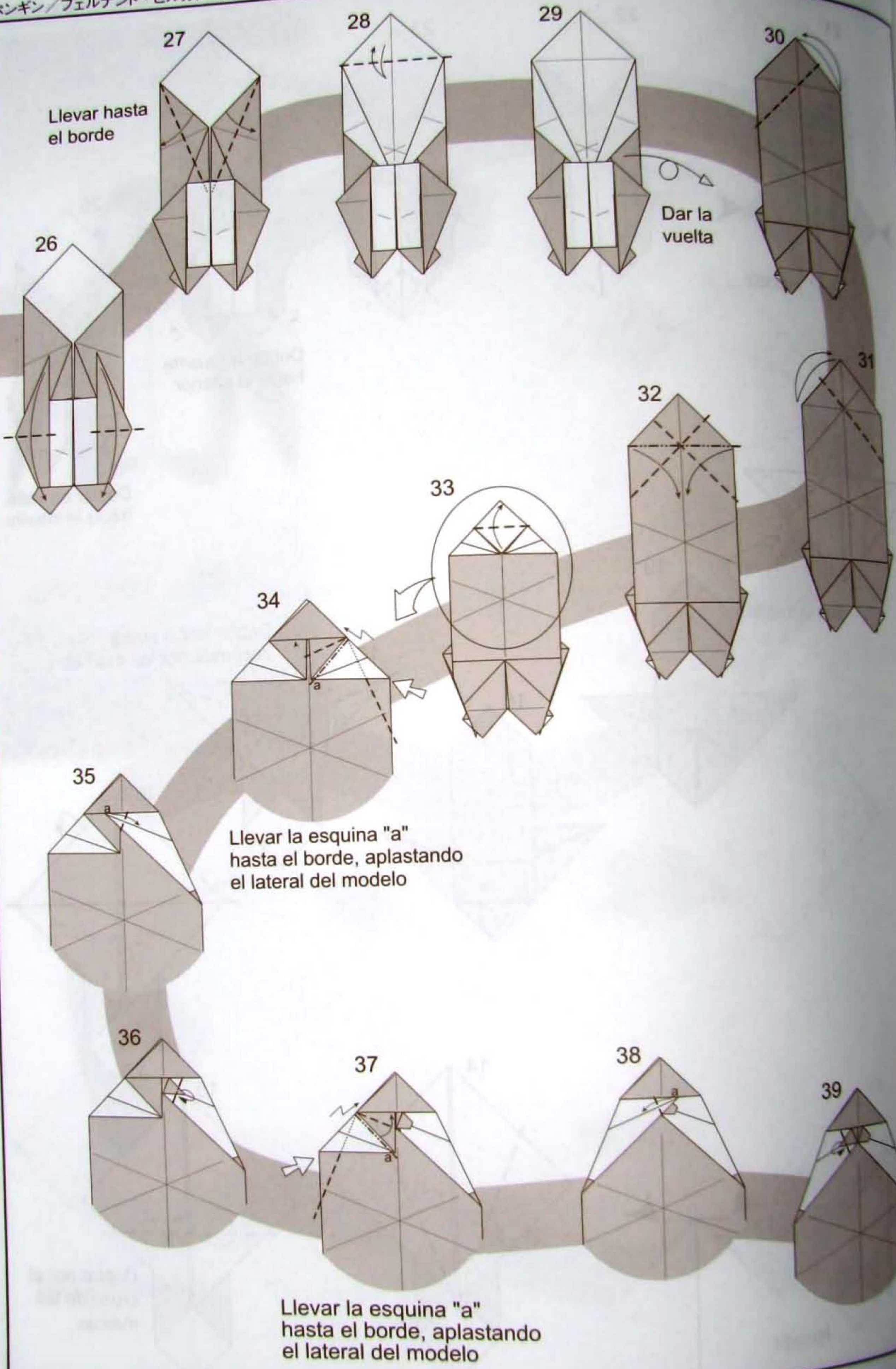

Llevar hasta el borde

Dar la vuelta

Llevar la esquina "a" hasta el borde, aplastando el lateral del modelo

Llevar la esquina "a" hasta el borde, aplastando el lateral del modelo

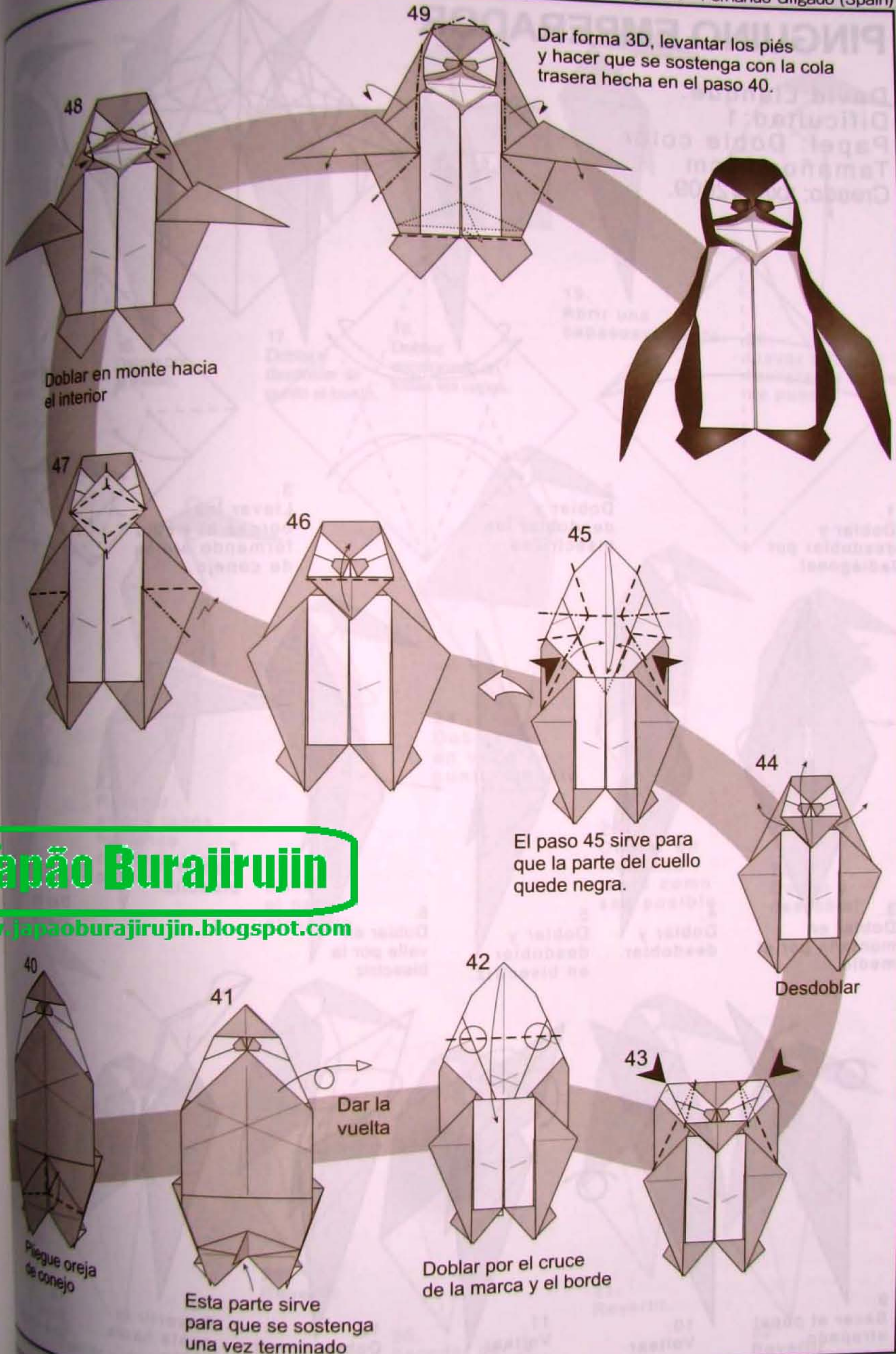

Dar forma 3D, levantar los piés y hacer que se sostenga con la cola trasera hecha en el paso 40.

Doblar en monte hacia el interior

El paso 45 sirve para que la parte del cuello quede negra.

Desdoblar

Dar la vuelta

Doblar por el cruce de la marca y el borde

Esta parte sirve para que se sostenga una vez terminado

Pieque oreja de conejo

Japão Burajirujin

www.japaoburajirujin.blogspot.com

PINGUINO EMPERADOR

David Llanque.

Dificultad: 1

Papel: Doble color

Tamaño: 15cm

Creado: xx/08/2009.

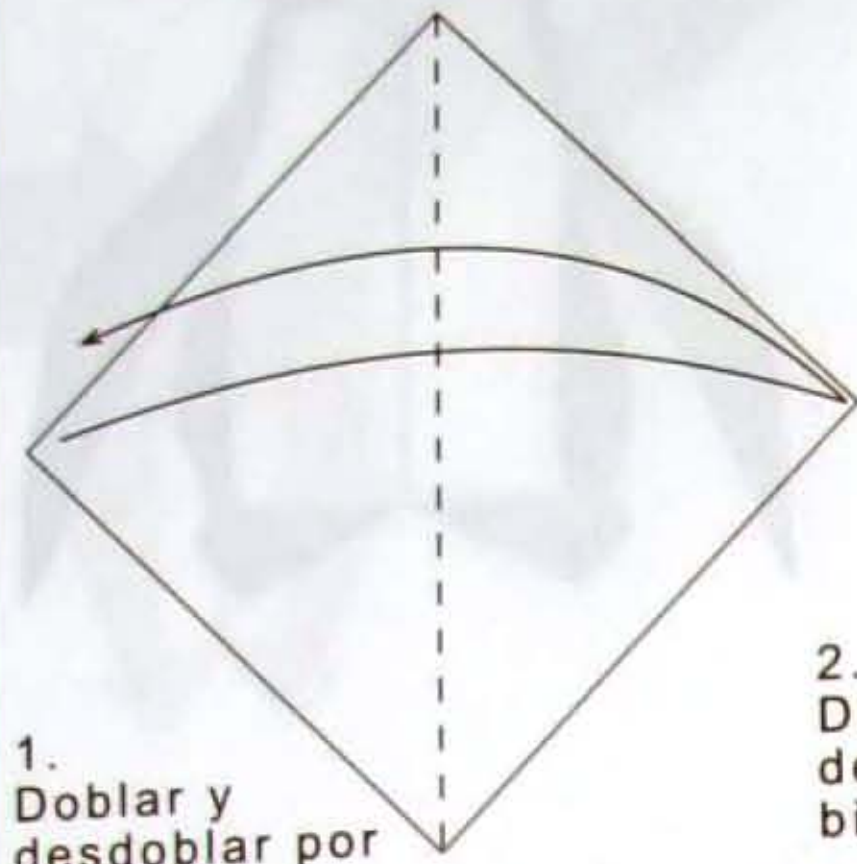
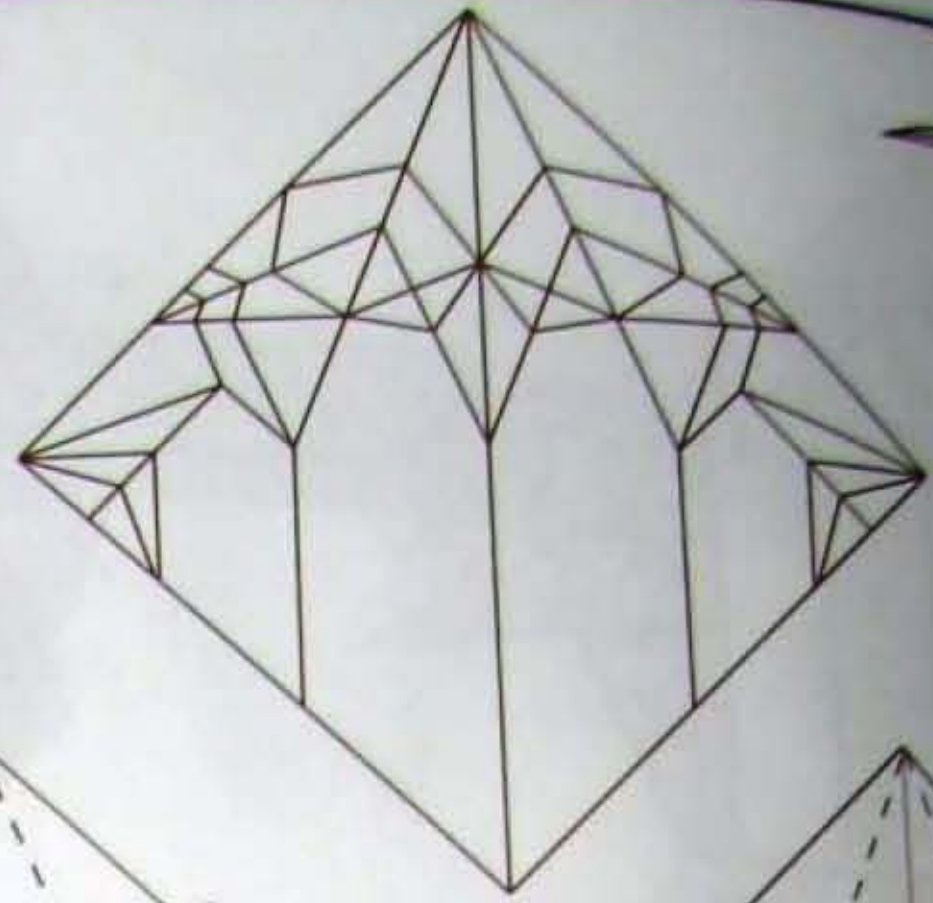

1. Doblar y desdoblar por la diagonal.

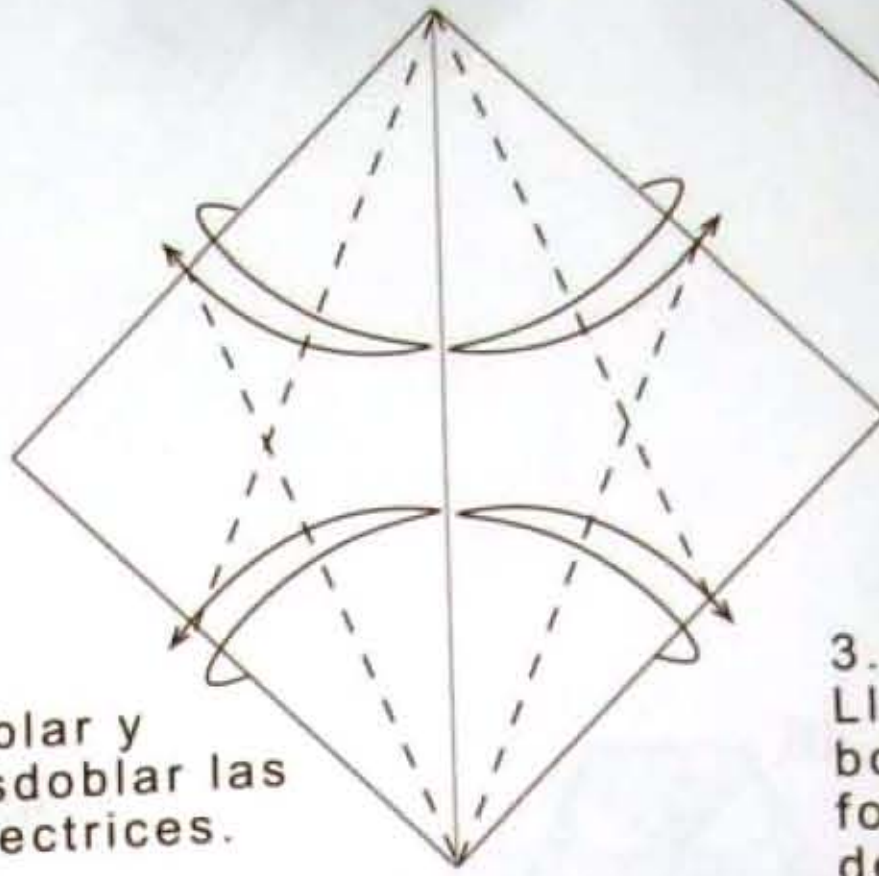

2. Doblar y desdoblar las bisectrices.



3. Llevar los bordes al medio formando orejas de conejo.

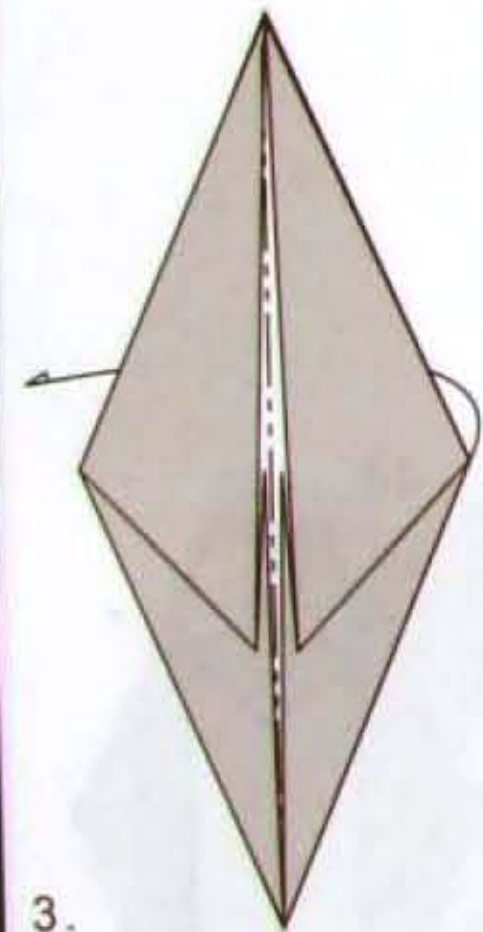

3. Doblar en montaña por el medio.

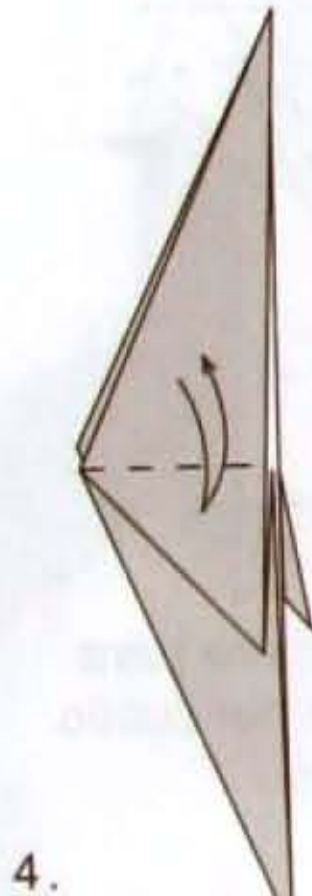

4. Doblar y desdoblar.

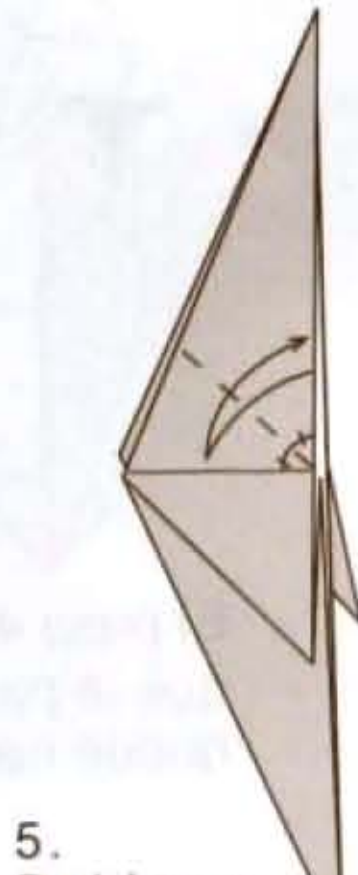

5. Doblar y desdoblar en bisectriz.

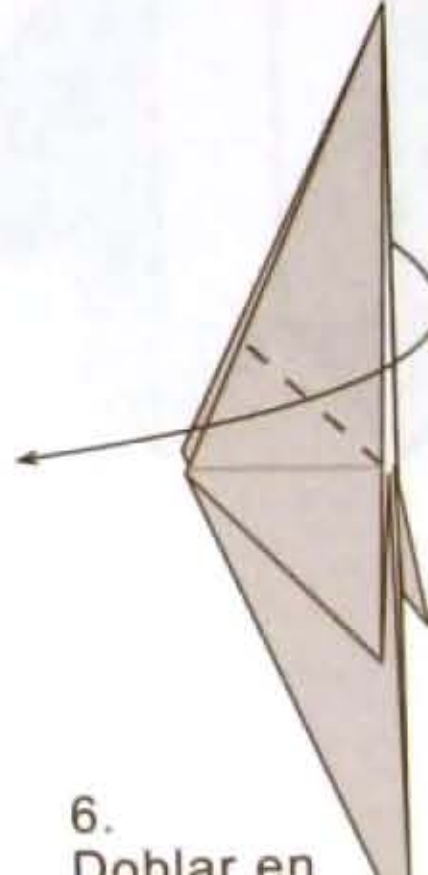

6. Doblar en valle por la bisectriz.

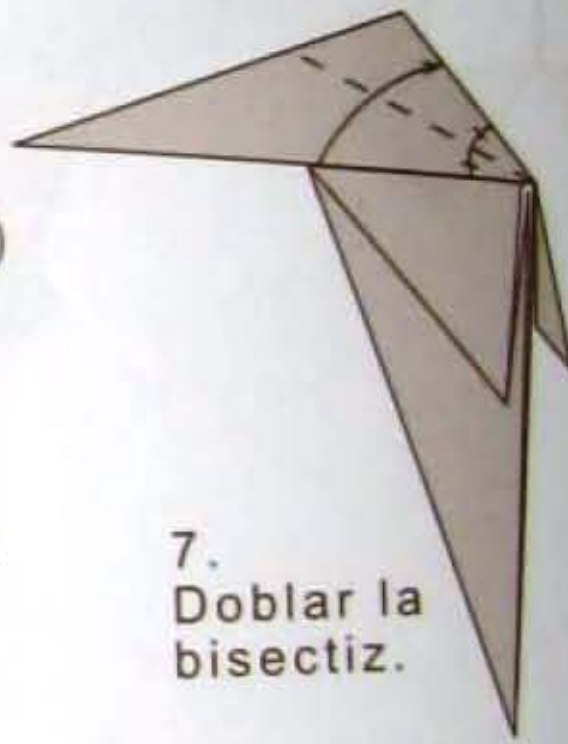

7. Doblar la bisectriz.

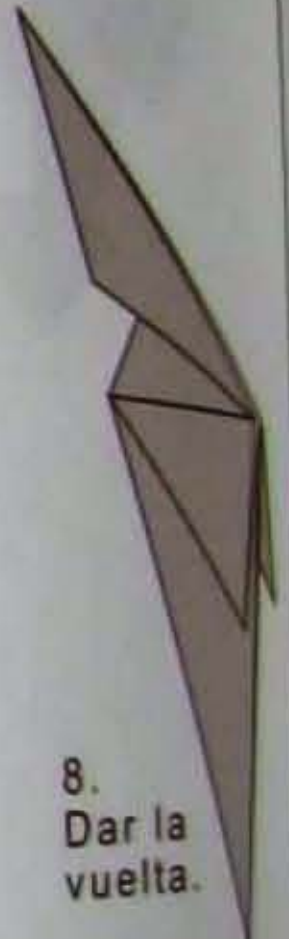

8. Dar la vuelta.

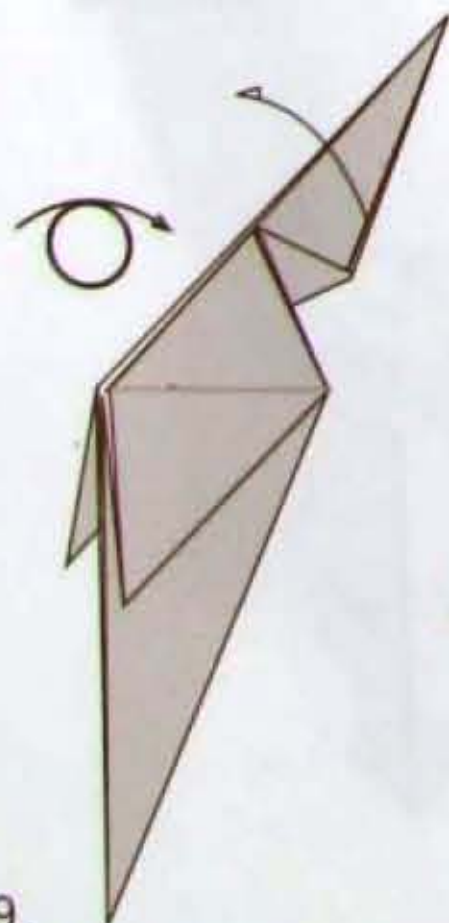

9. Sacar el papel atrapado.

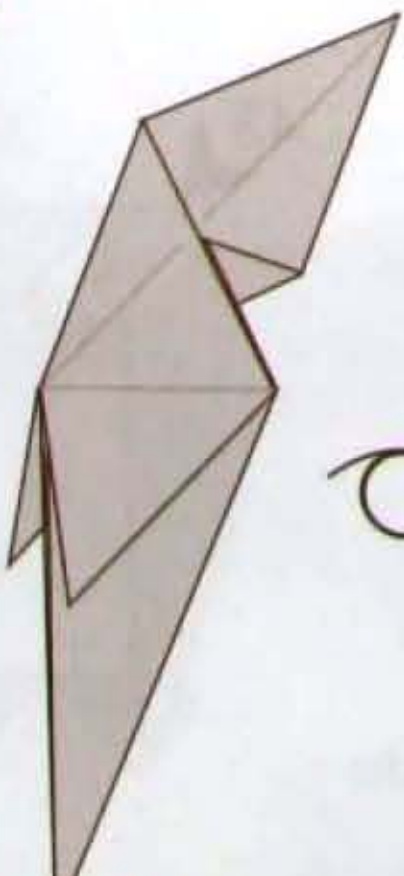

10. Voltear

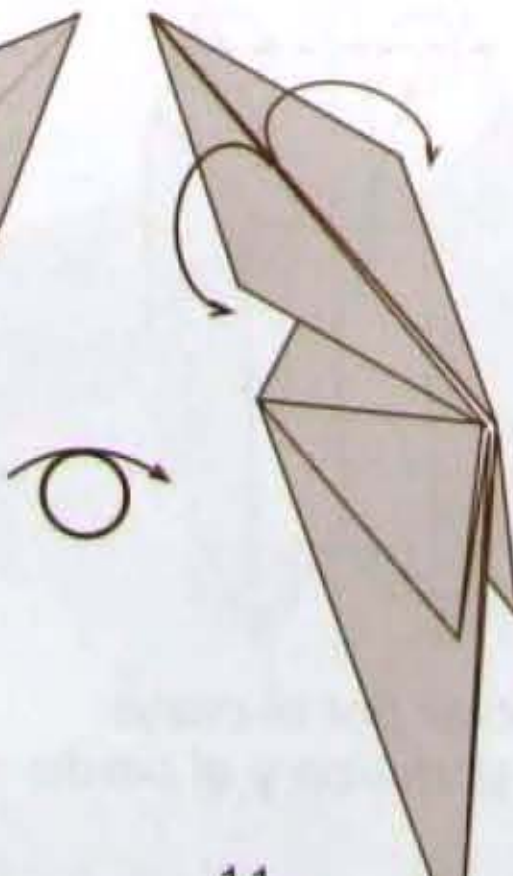

11. Voltear ambas capas

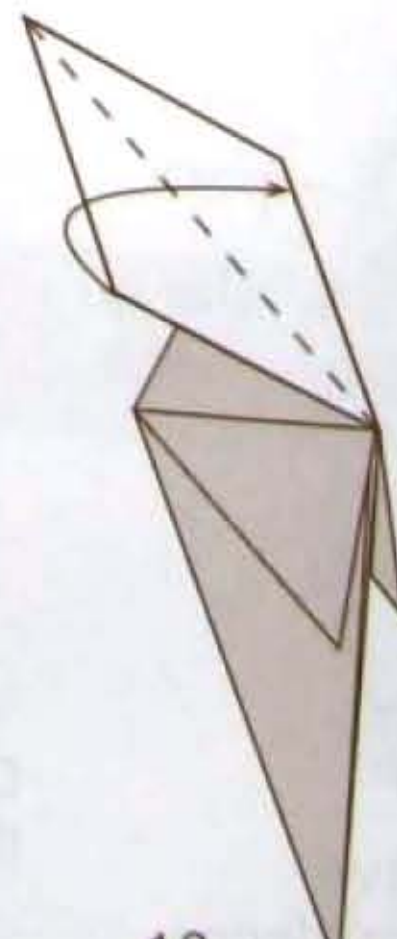

12. Doblar por el medio en valle.

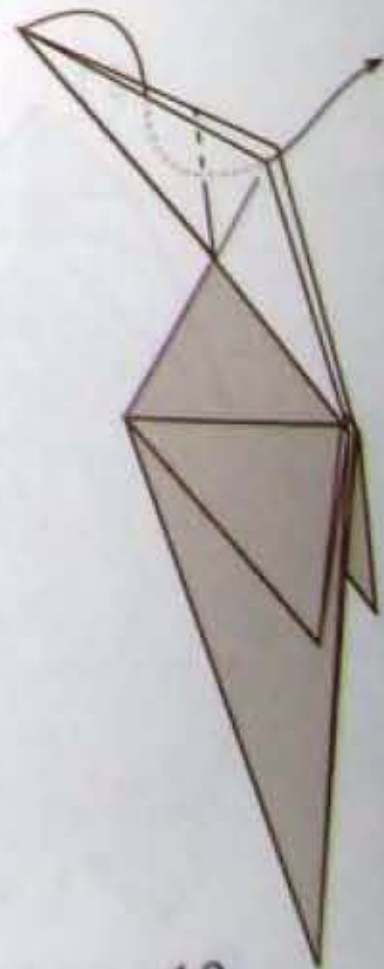

13. Revertir la punta hacia abajo.



14. Bajar una capa.

15. Voltear capas.

21: Cerrar repetir

27. Doble monta

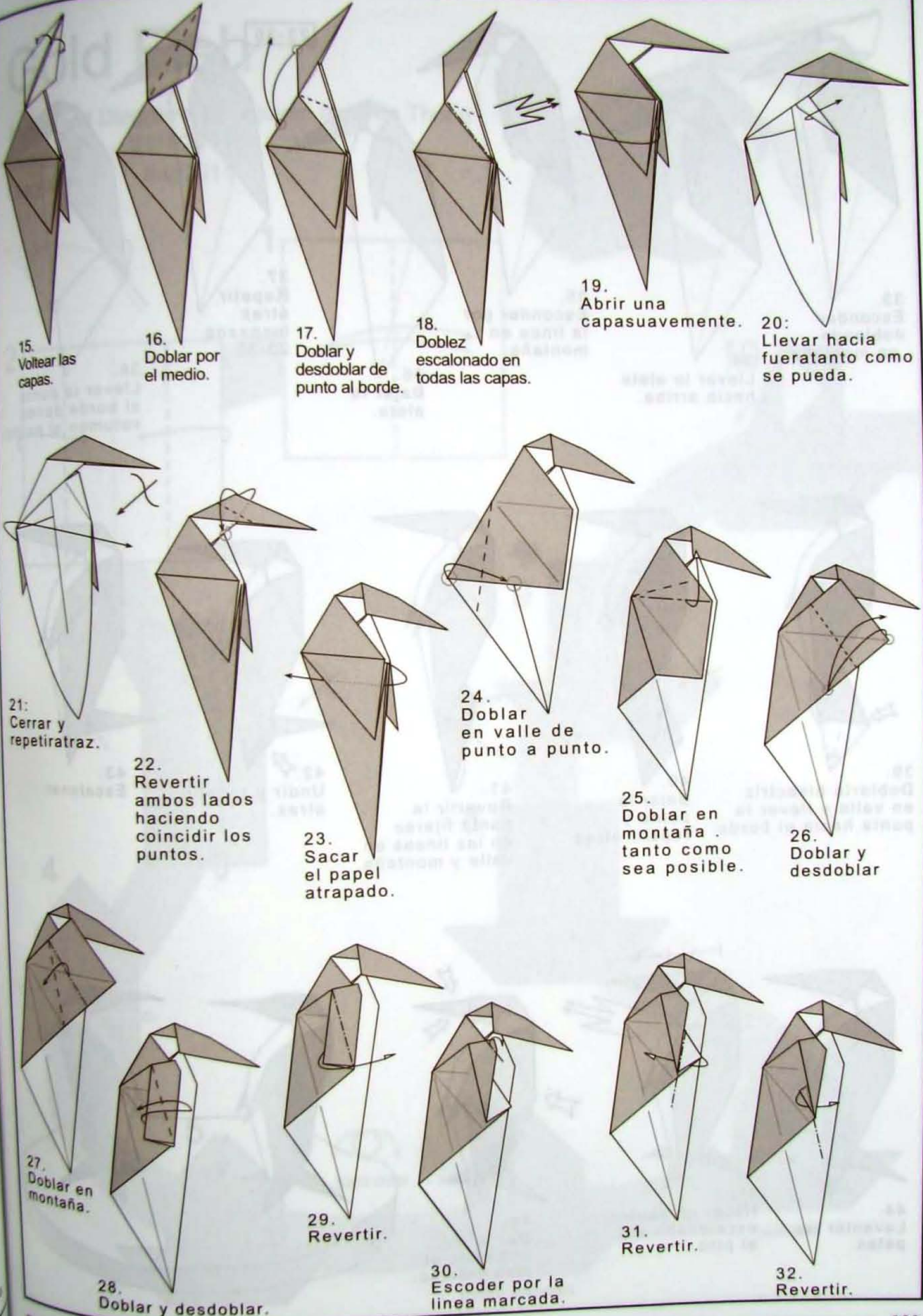

15. Voltear las capas.

16. Doblar por el medio.

17. Doblar y desdoblar de punto al borde.

18. Doble escalonado en todas las capas.

19. Abrir una capas suavemente.

20: Llevar hacia fueratanto como se pueda.

21: Cerrar y repetirtraz.

22. Revertir ambos lados haciendo coincidir los puntos.

23. Sacar el papel atrapado.

24. Doblar en valle de punto a punto.

25. Doblar en montaña . tanto como sea posible.

26. Doblar y desdoblar

27. Doblar en montaña.

29. Revertir.

31. Revertir.

28. Doblar y desdoblar.

30. Escoder por la linea marcada.

32. Revertir.

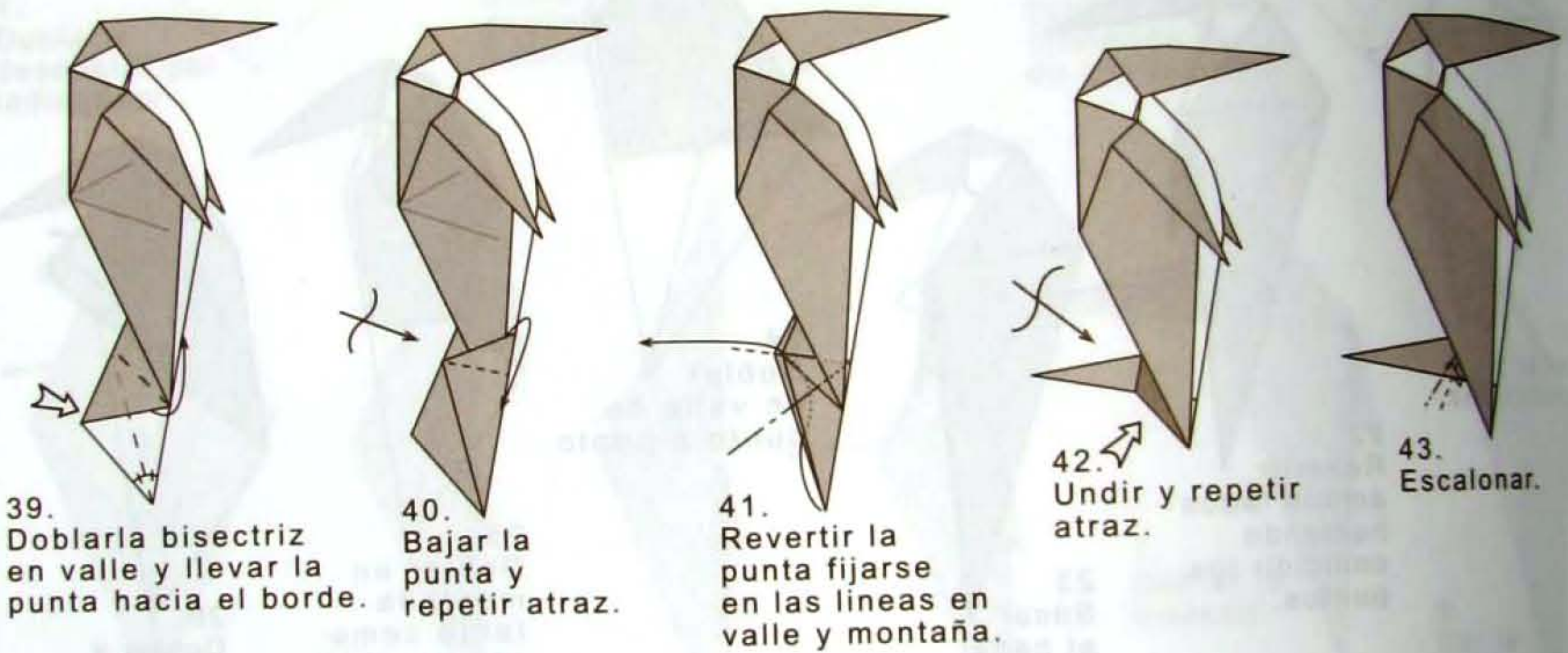
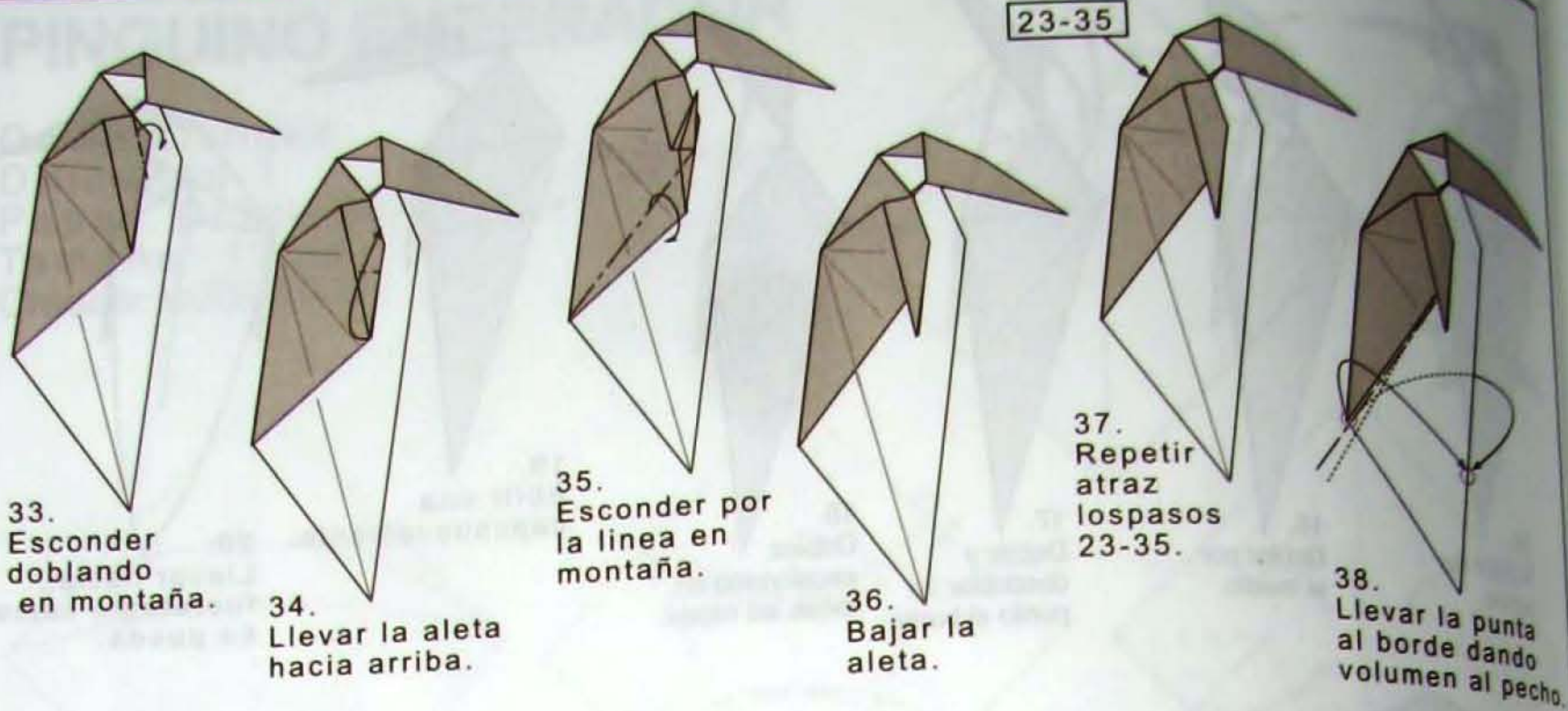

GO
Model a
Design
Diagram



Gold Fish

Model and Diagrams by Nguyen Nguyen Thong
Designed: 21/1/2011
Diagramed: 8/6/2011

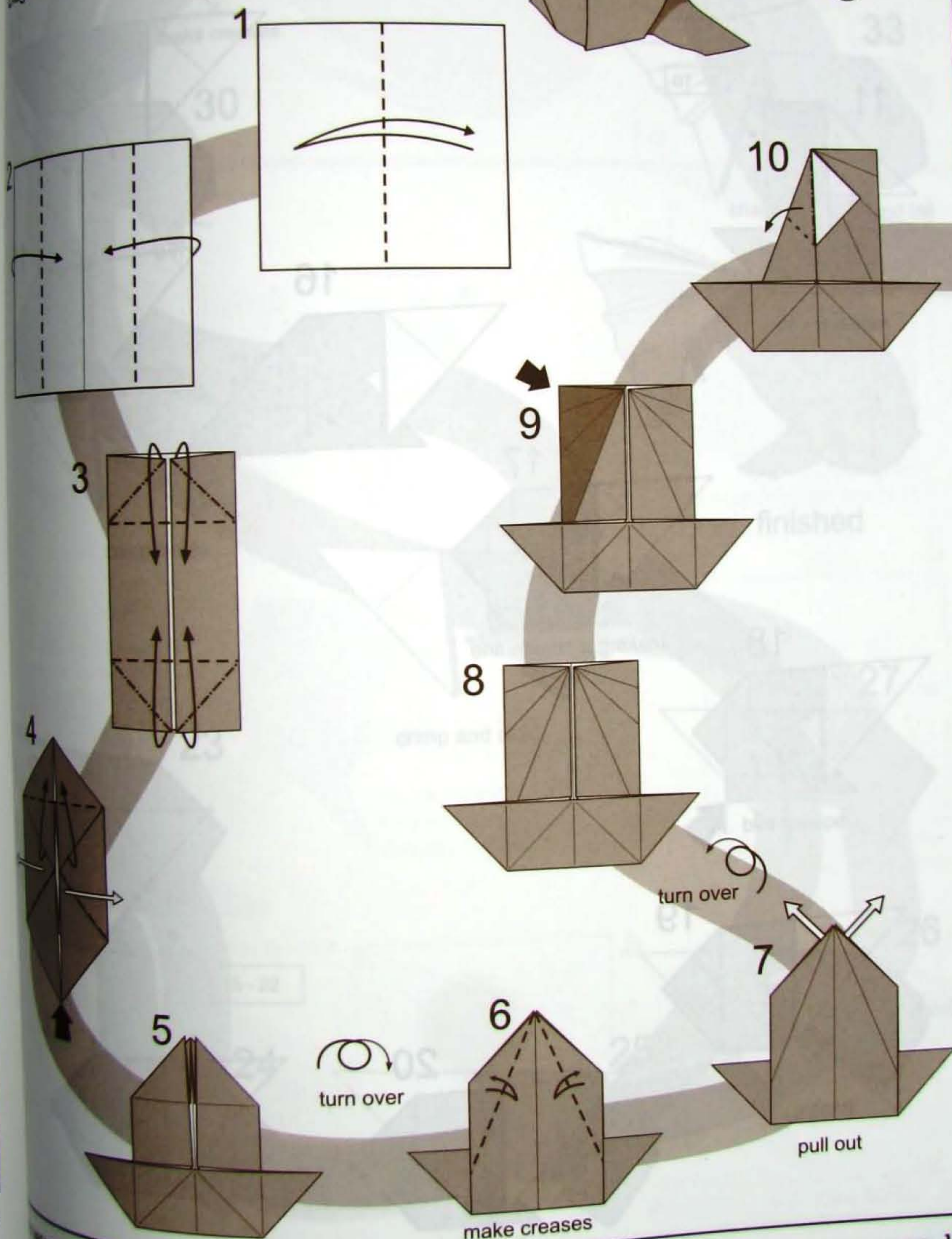
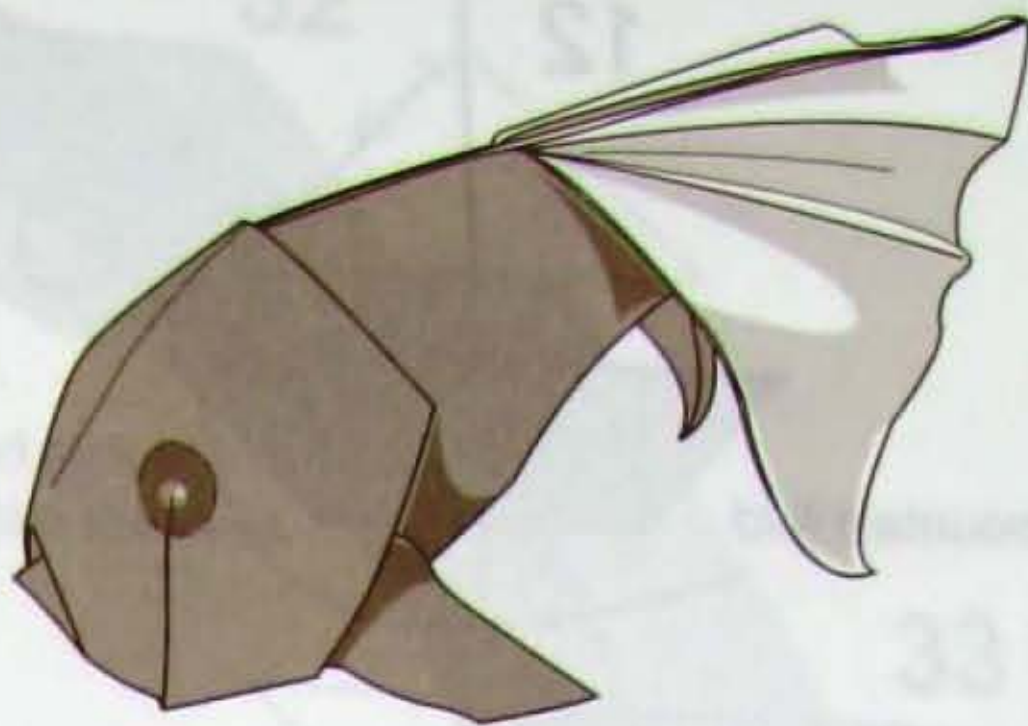

a punta
dando
al pecho.

lonar.

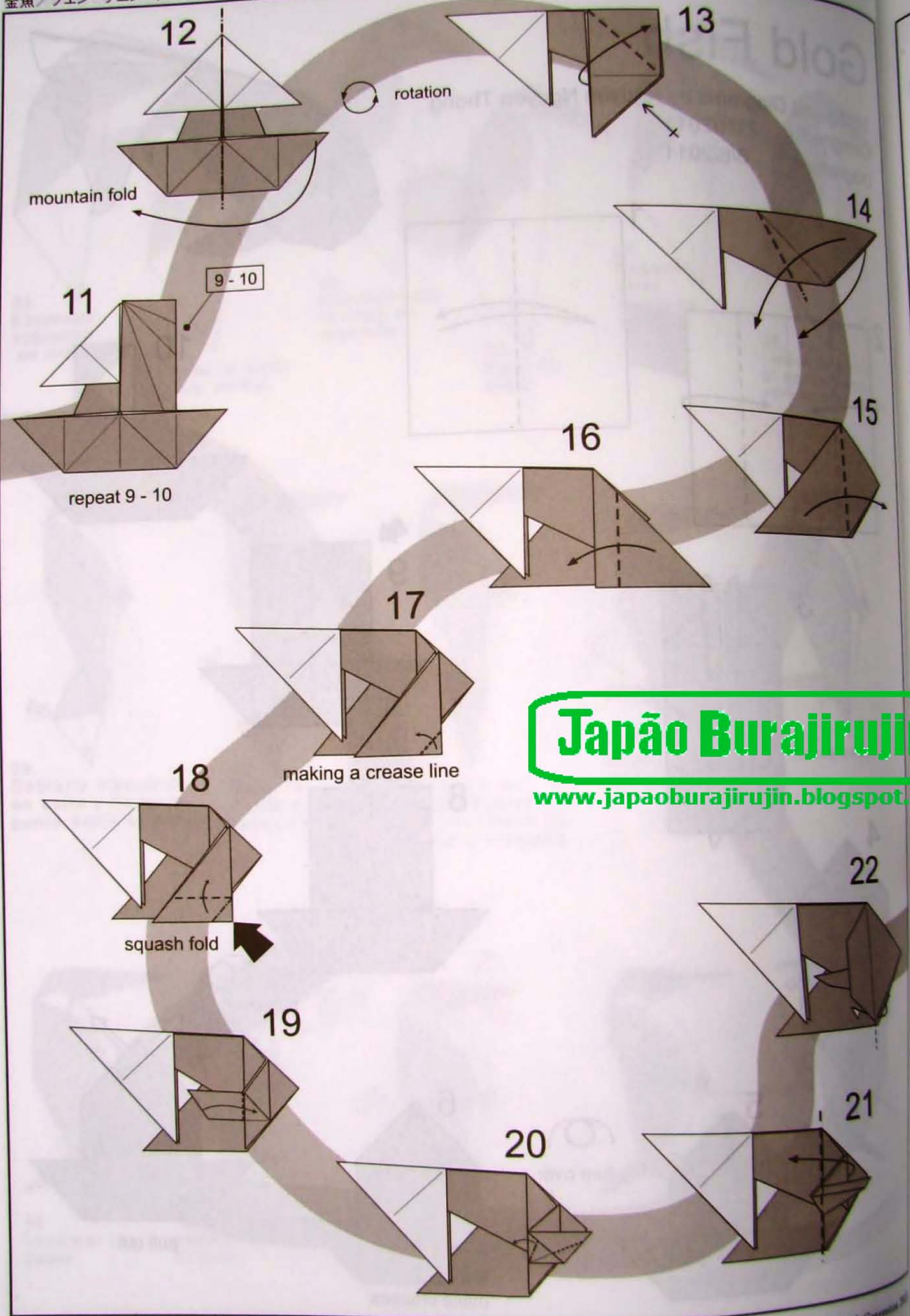

Japão Burajirujin

www.japaoburajirujin.blogspot.com

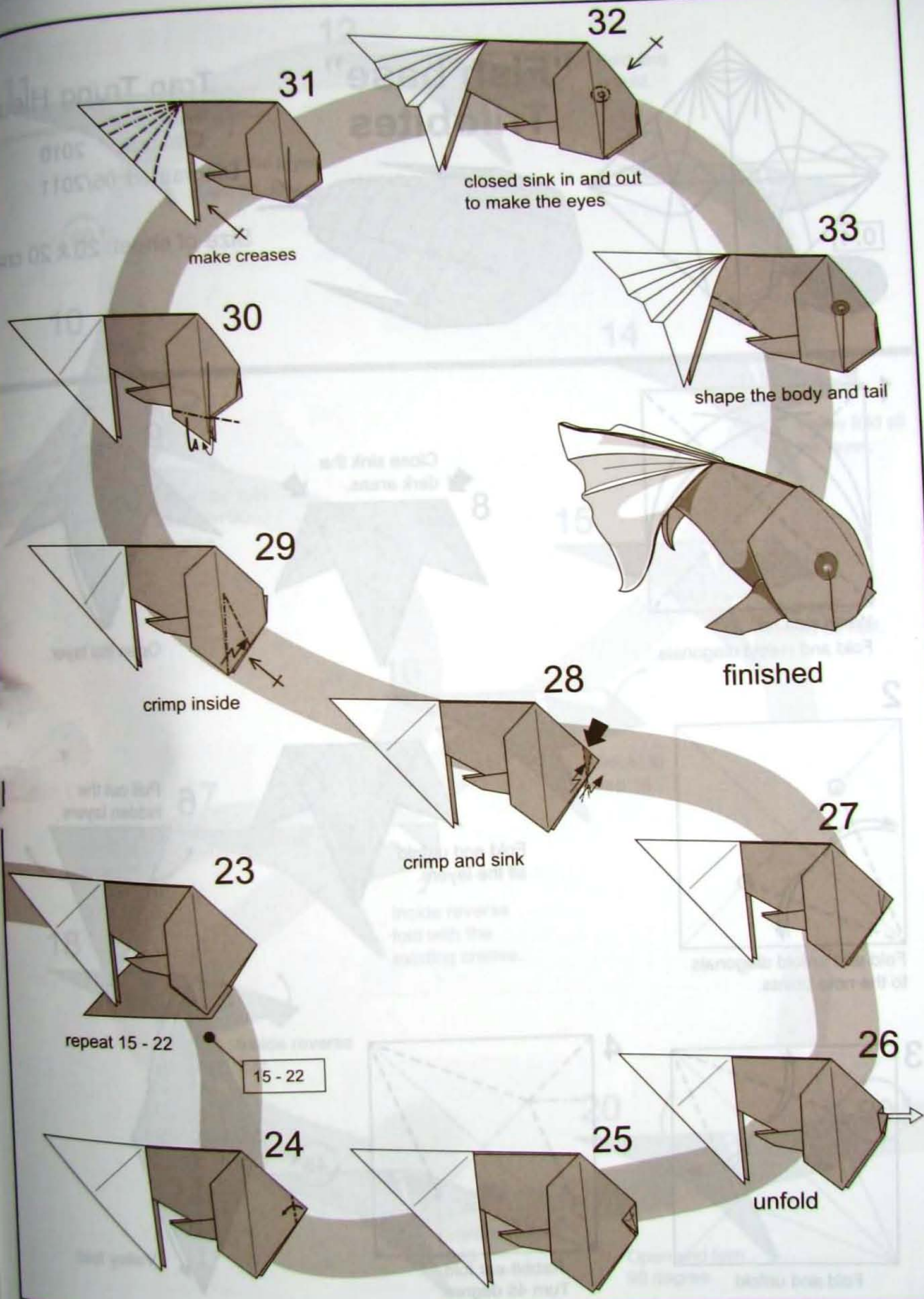

"Fish base" Trilobites

Tran Trung Hieu

Created: 2010

Diagramed: 06/2011

Size of sheet: 20 x 20 cm.

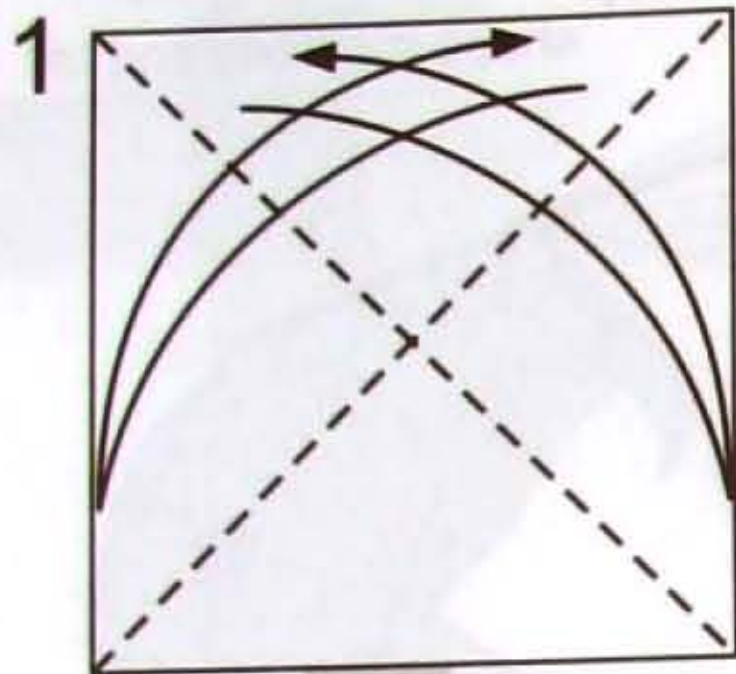
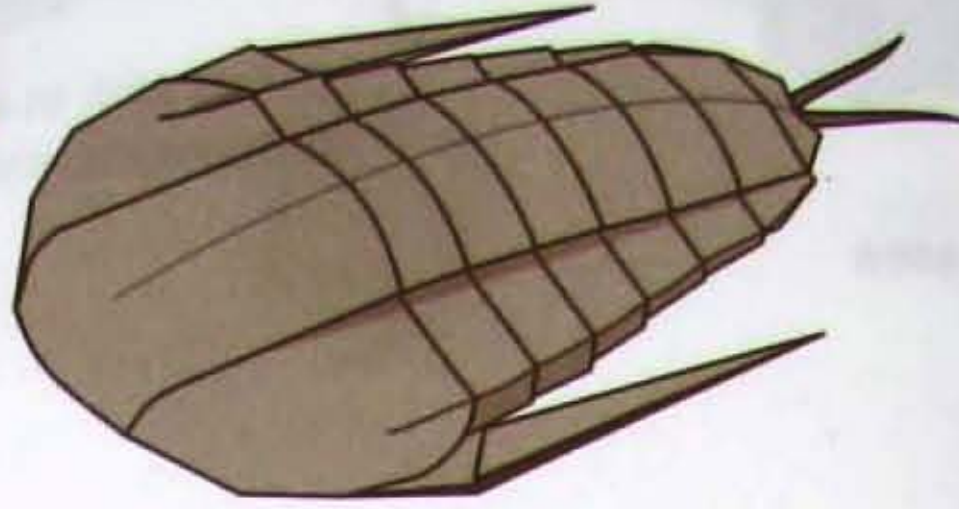
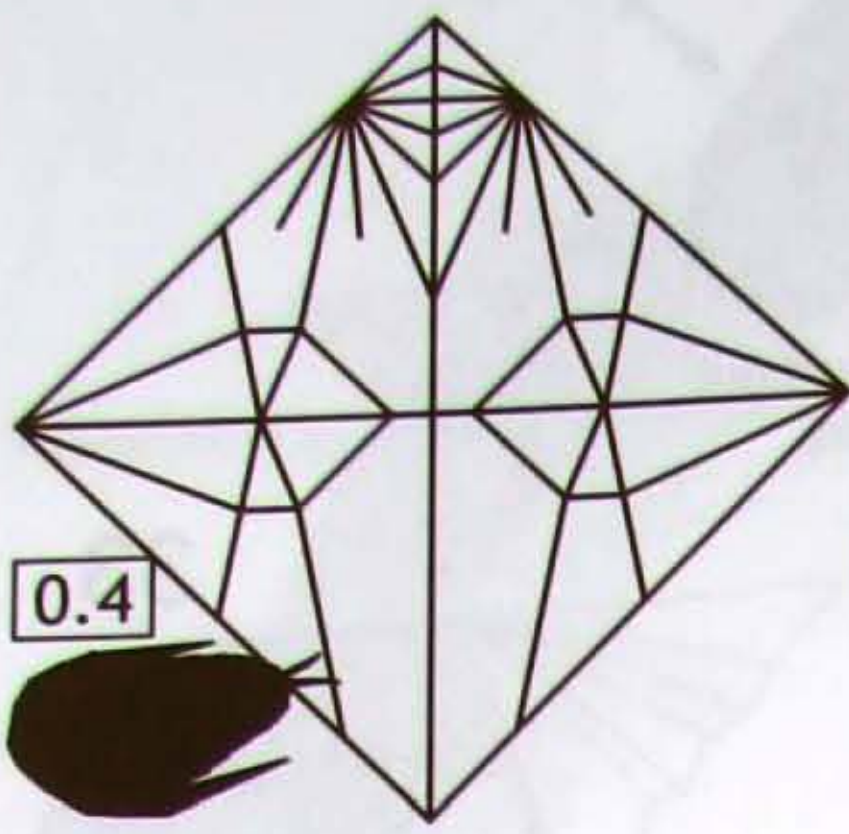

1
White side up.
Fold and unfold diagonals.

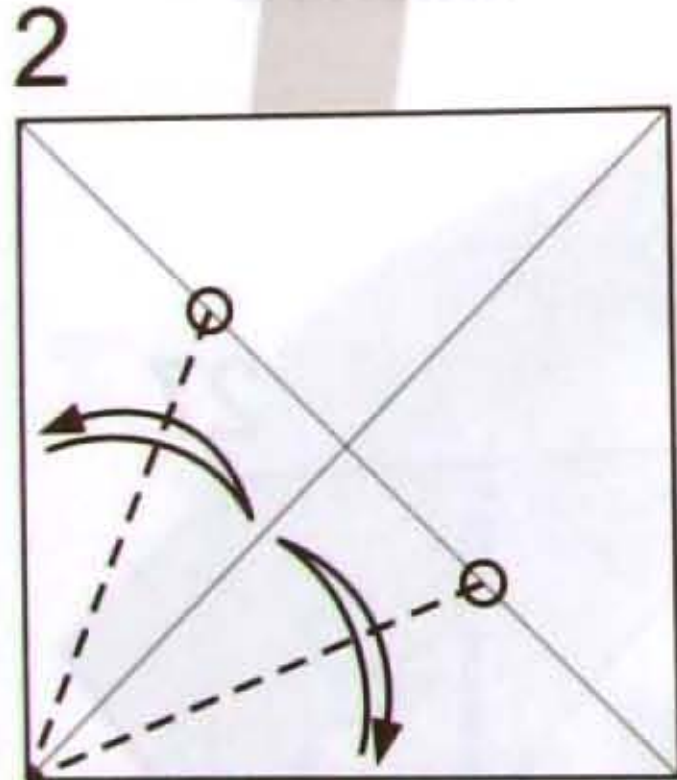

2
Fold and unfold diagonals
to the note points.

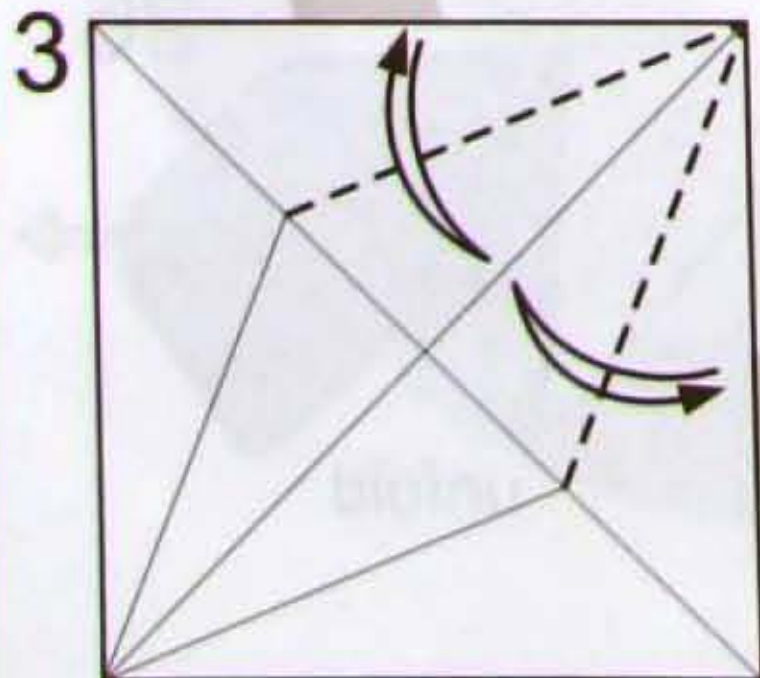

3
Fold and unfold

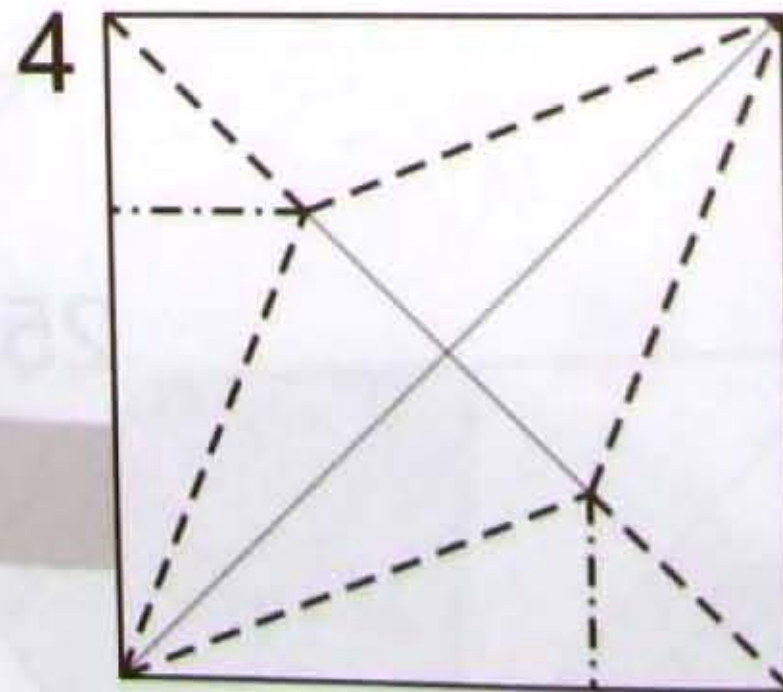

4
Rabbit-ear fold.
Turn 45 degree.

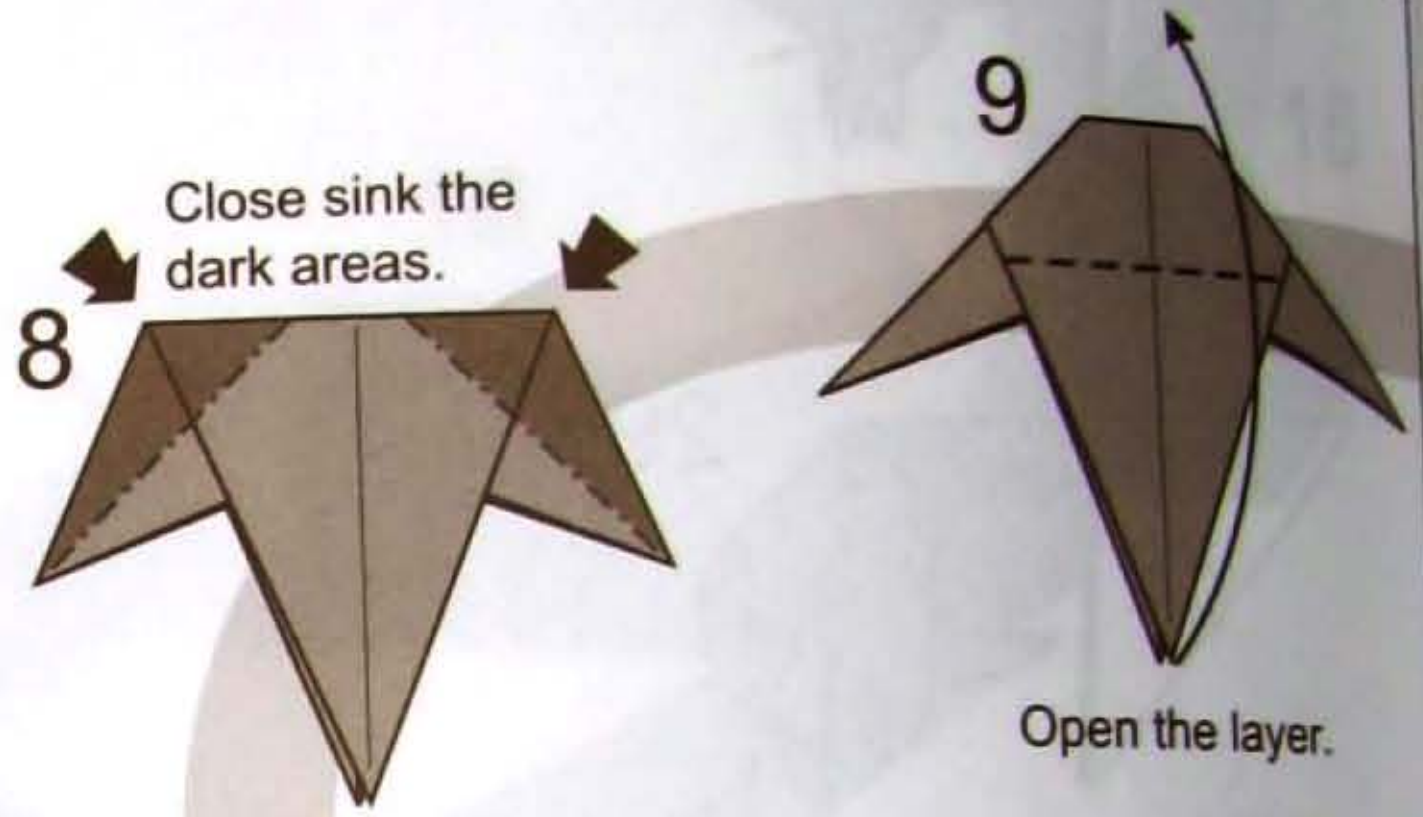

8
Close sink the dark areas.

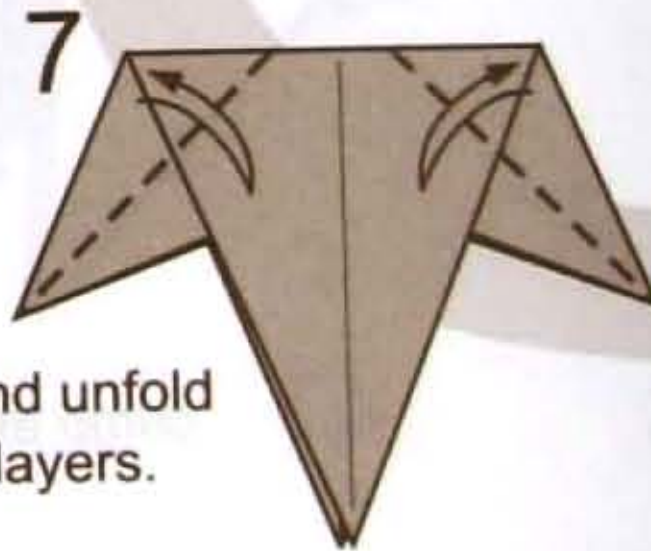

7
Fold and unfold
all the layers.

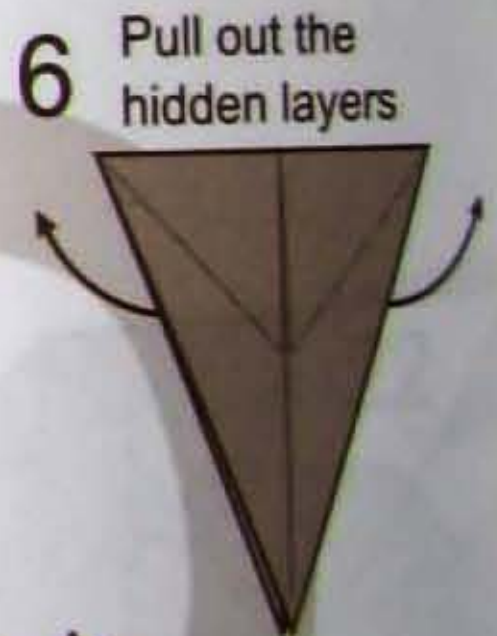

6
Pull out the
hidden layers

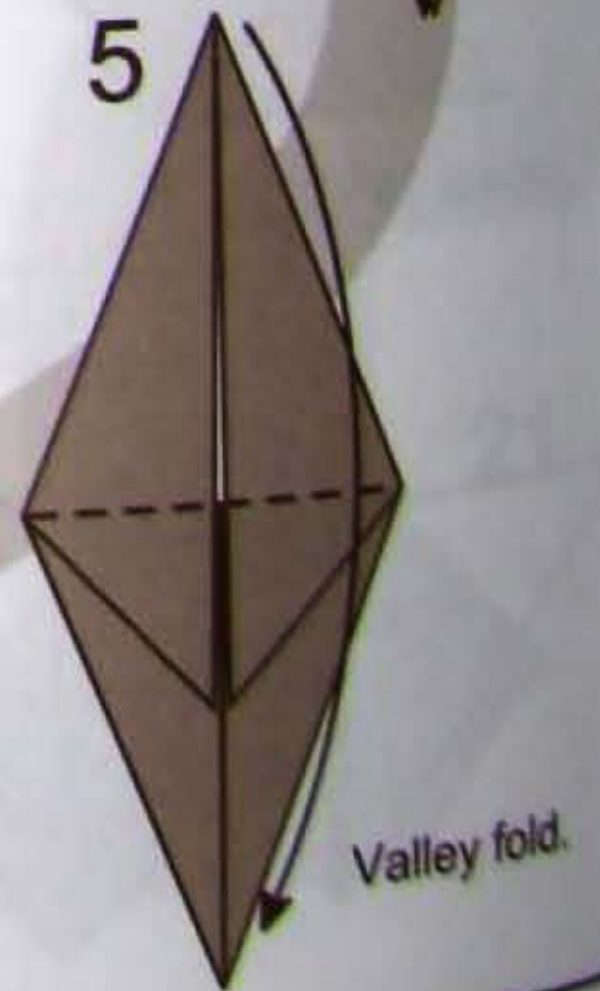

5
Valley fold.

11

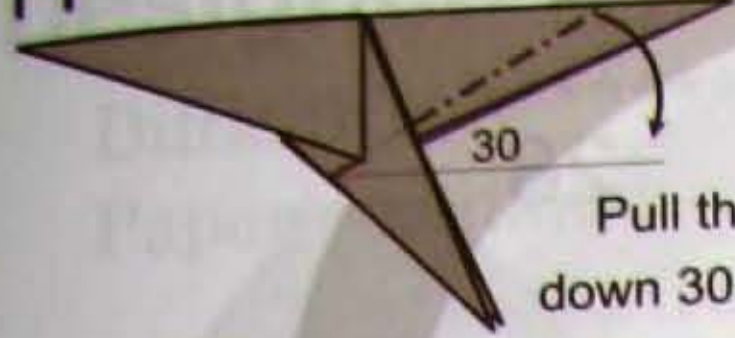

Pull the layer down 30 degree.

12

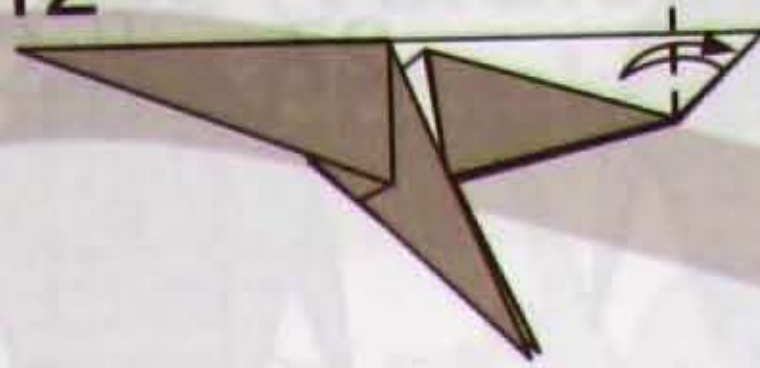

Fold and unfold.

13

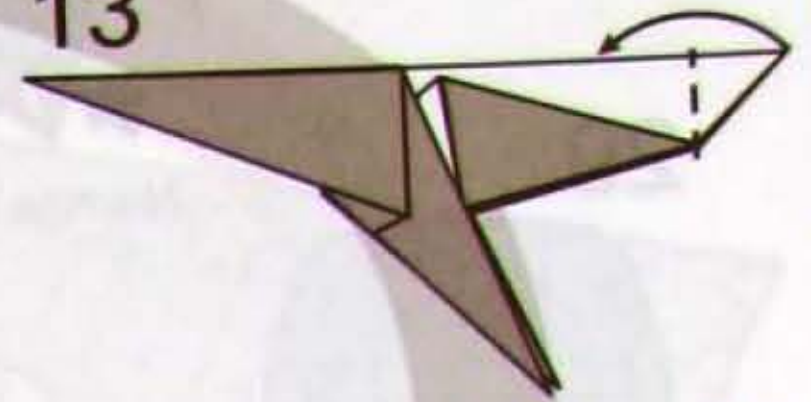

Outside reverse fold.

10

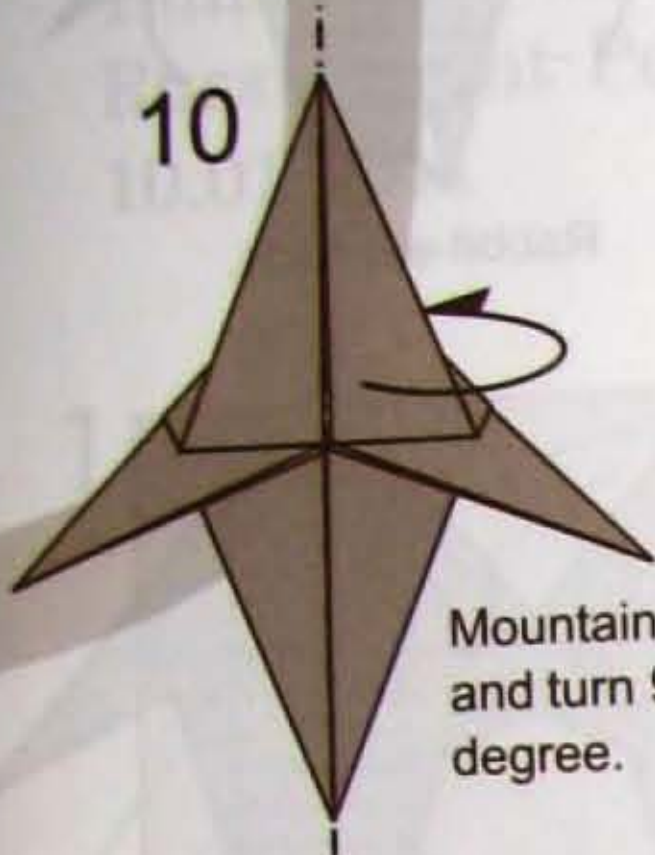

Mountain fold and turn 90 degree.

14

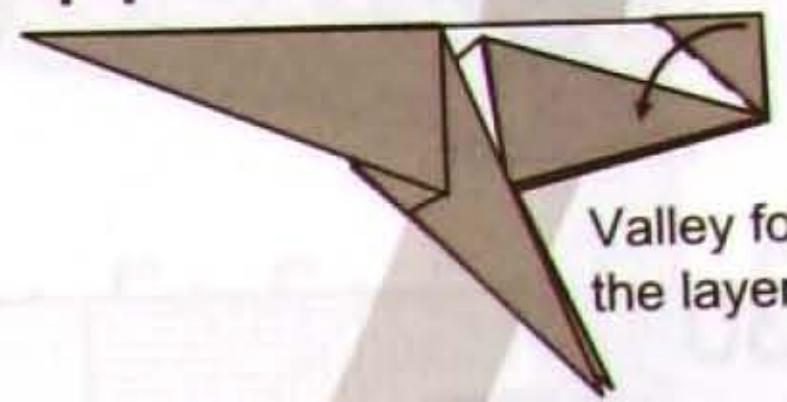

Valley fold all the layer.

15

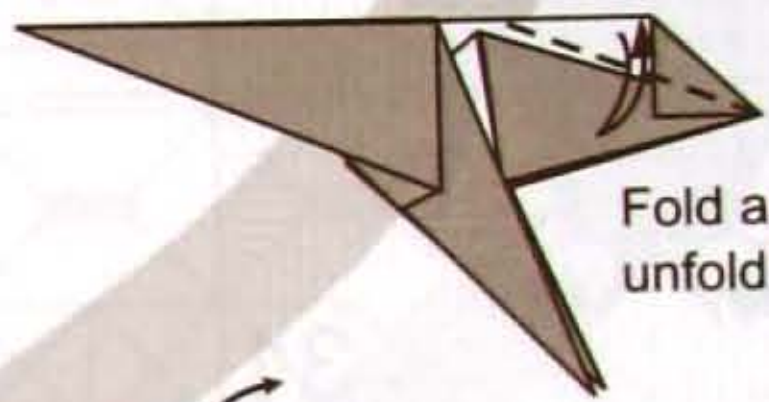

Fold and unfold by half.

16

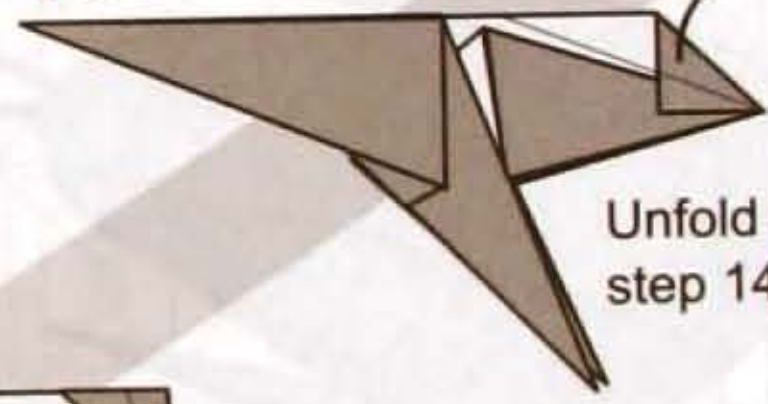

Unfold to step 14.

17

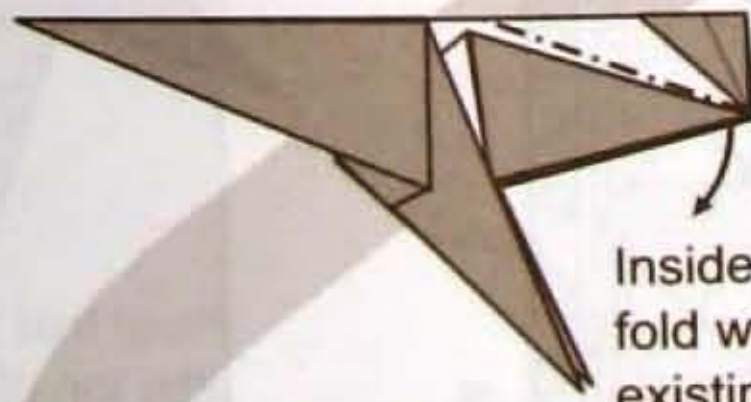

Inside reverse fold with the existing crease.

18

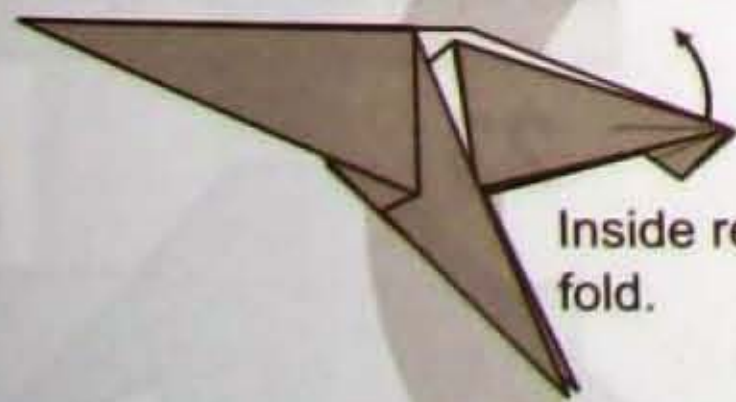

Inside reverse fold.

19

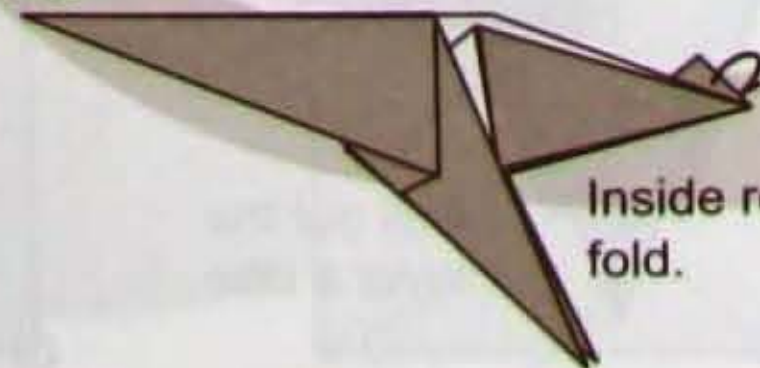

Inside reverse fold.

20

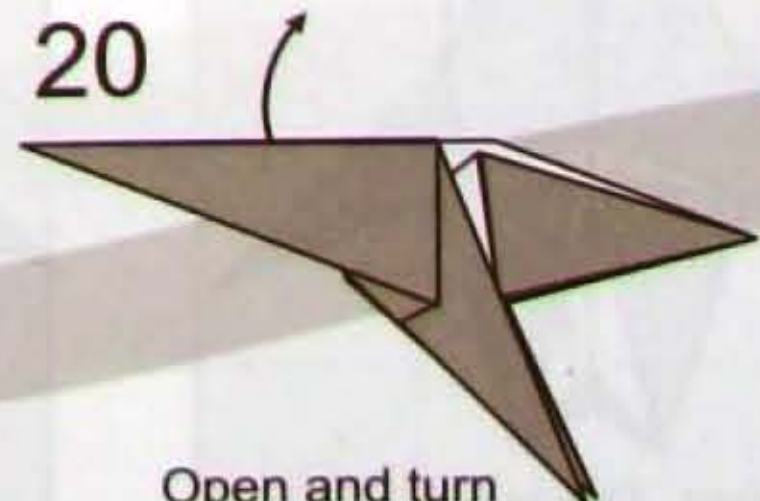

Open and turn 90 degree.

g Hieu

010
011

x 20 cm.

he
yers

ey fold.



Narrow the tails.



Pleat and hide the layer.

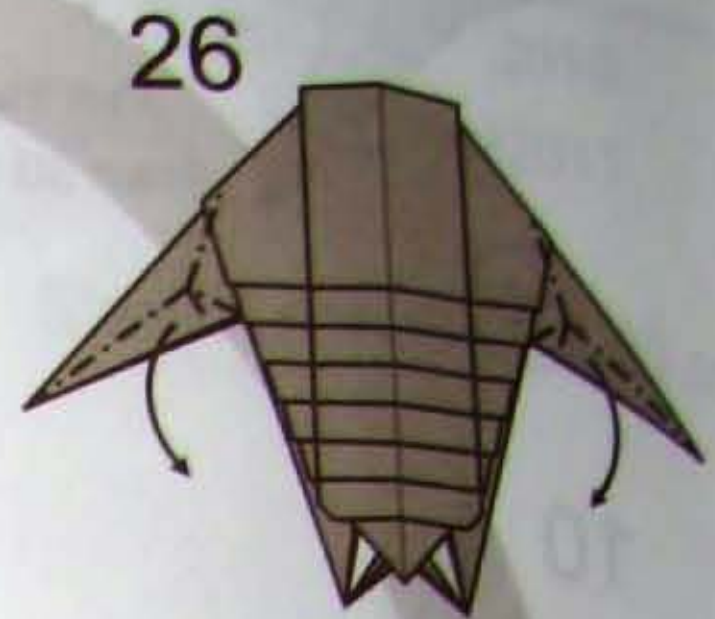

Rabbit-ear folds.



Hide inside.

Japão Burajirujin
www.japaoburajirujin.blogspot.com

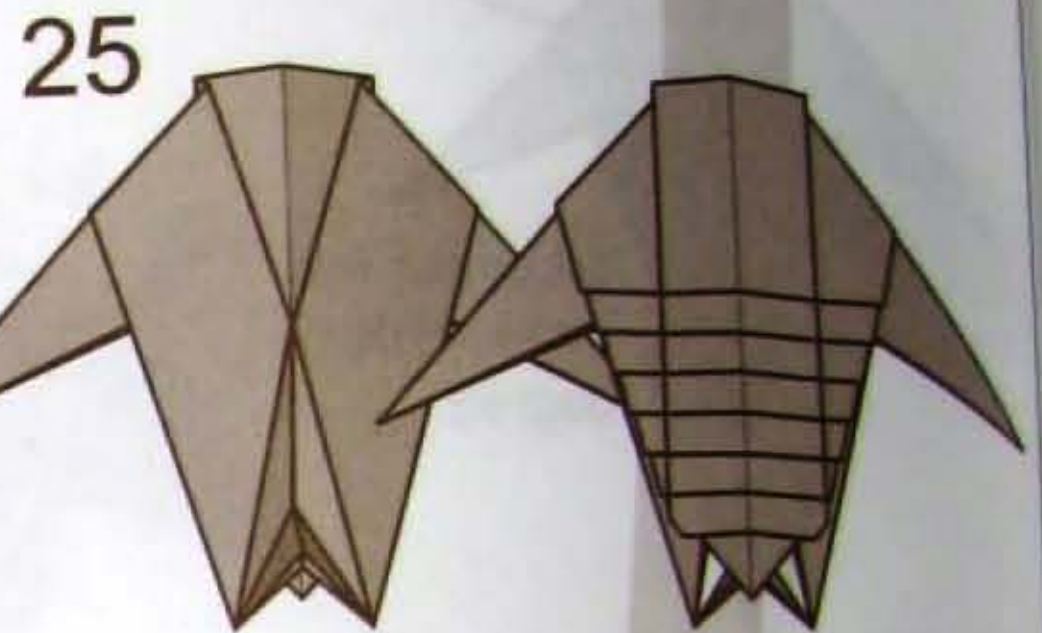

The result of folding step 24.
The front and backside



Curve the body and shape details.

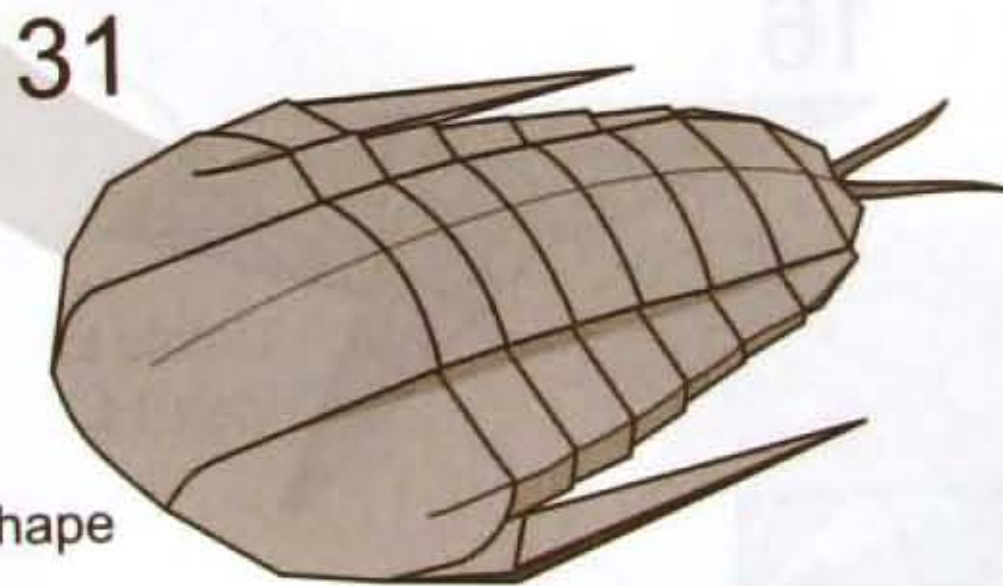

Model completed.

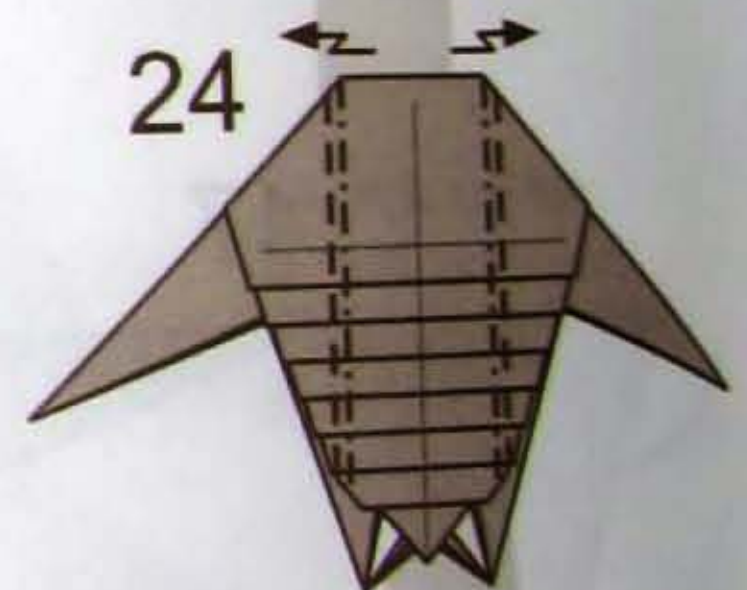

Pleat fold the top layer and a little top of the back layer.

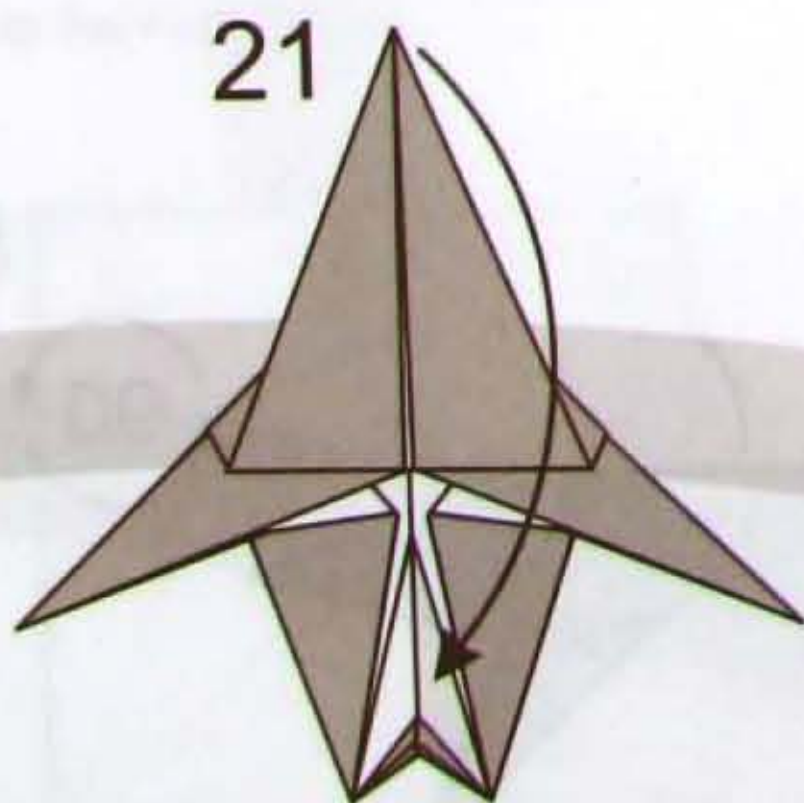

Unfold. The model will not lie flat.

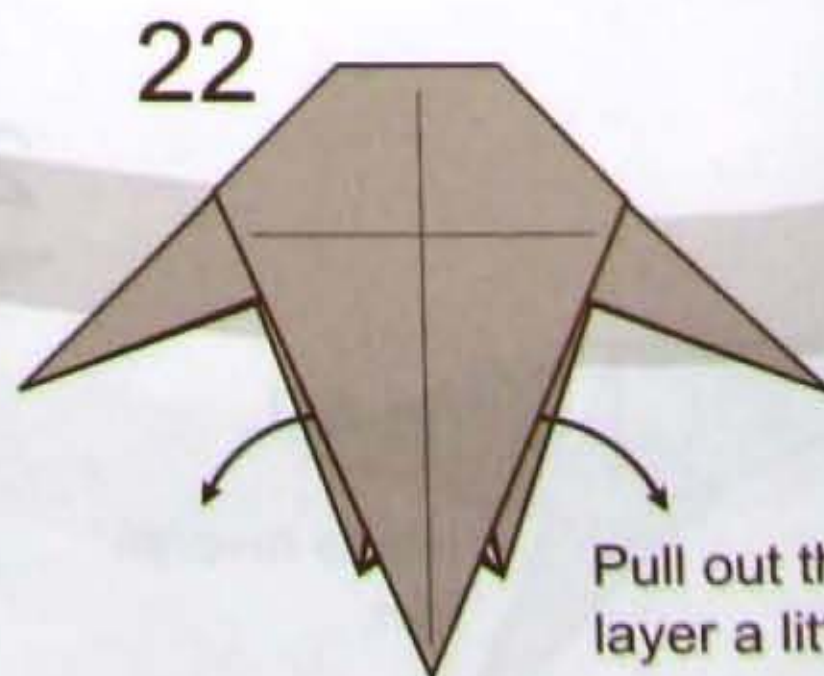

Pull out the layer a little.

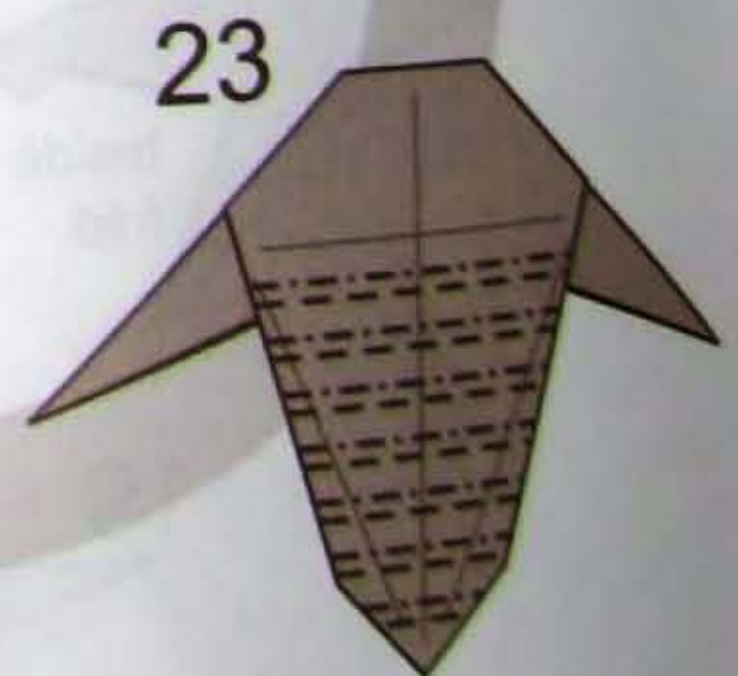

Pleat folds.

"Man
Desi

Diff
Pap
Rec
Bu
Ru
10

1

2

3

17

"Mantis shrimp op.62 (version 2.5)" Designed by Andrey Ermakov

Difficulty: *****
Paper: standart
- tissue (recomended)
Recomended size: 100-100 cm
Build time: 15 hours
Russia/Saint-Petersburg
10.01.2011

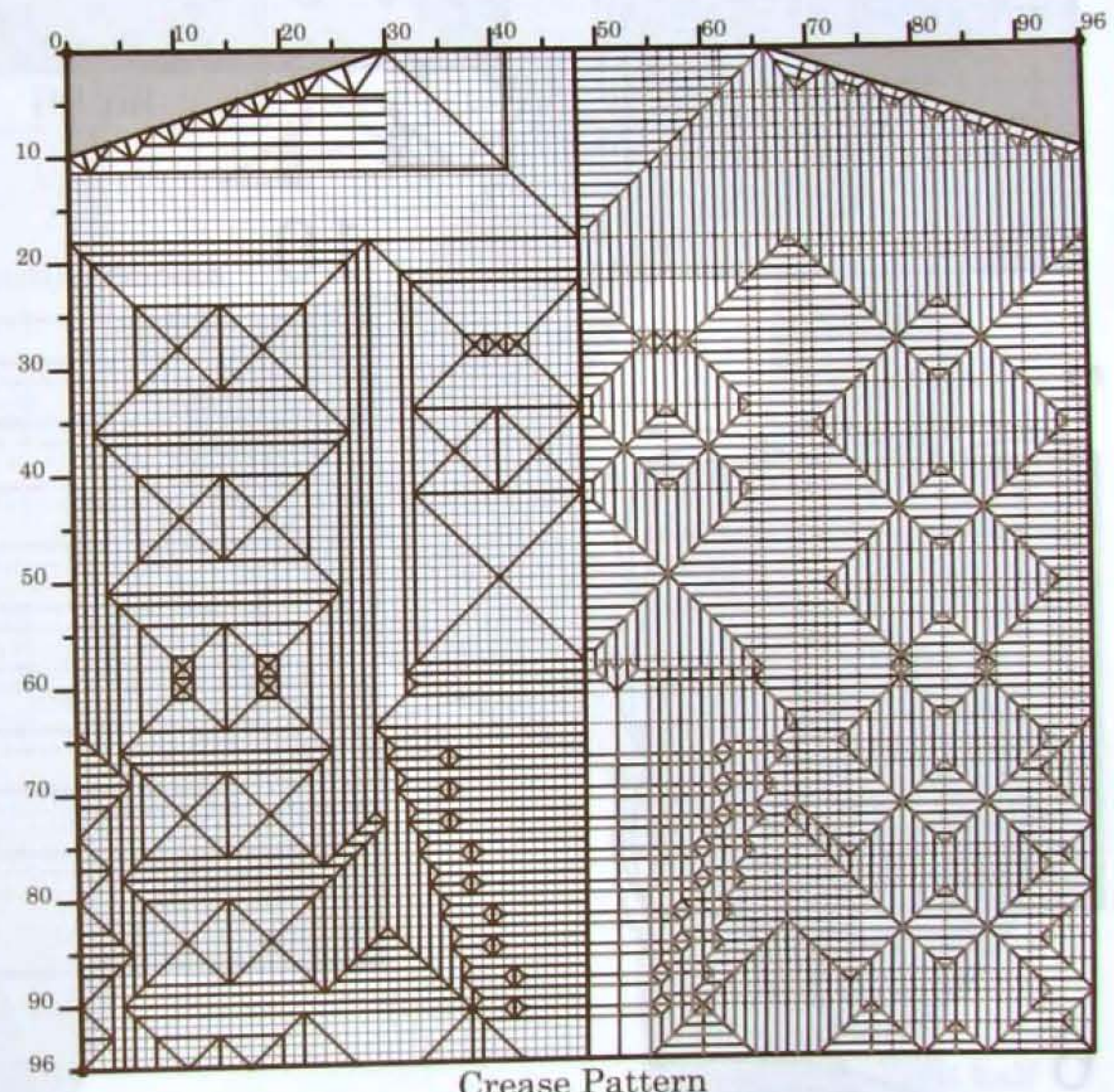
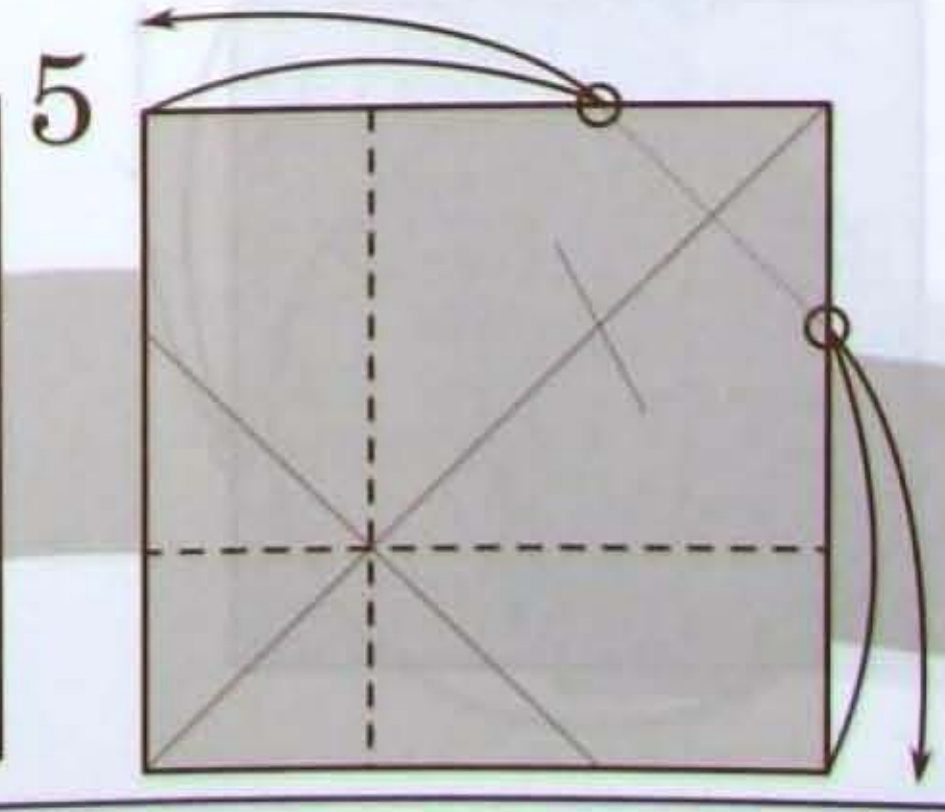
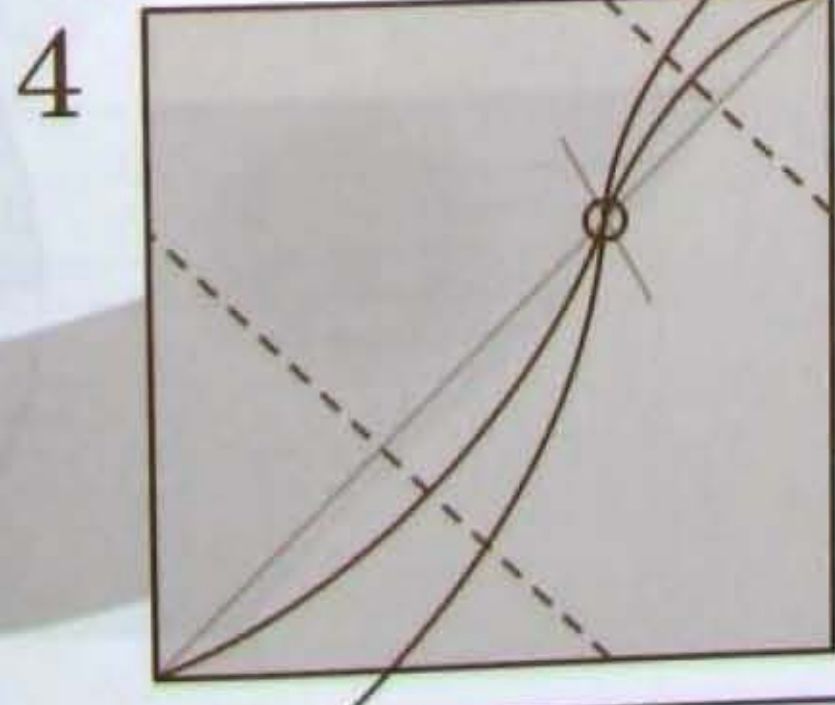
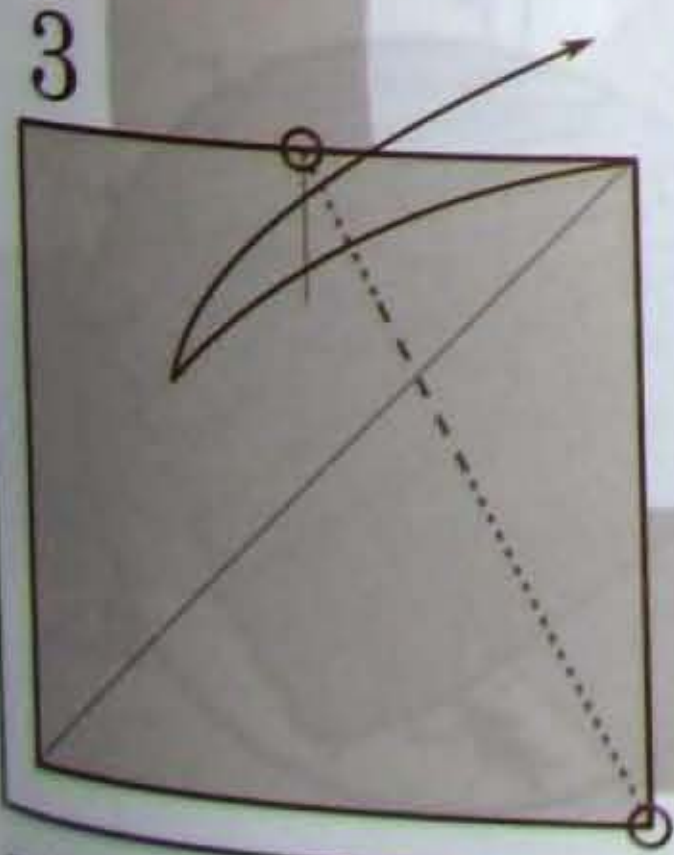
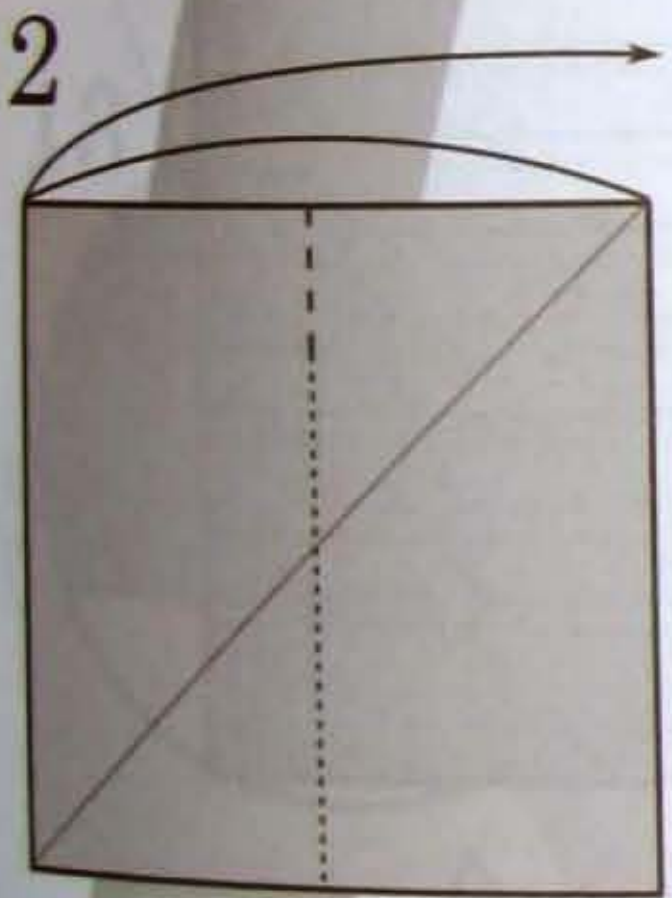
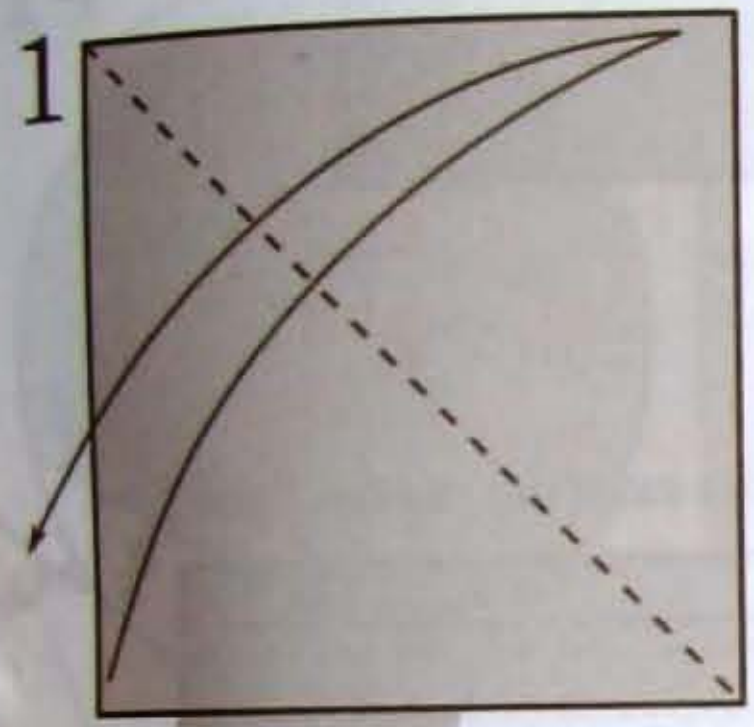
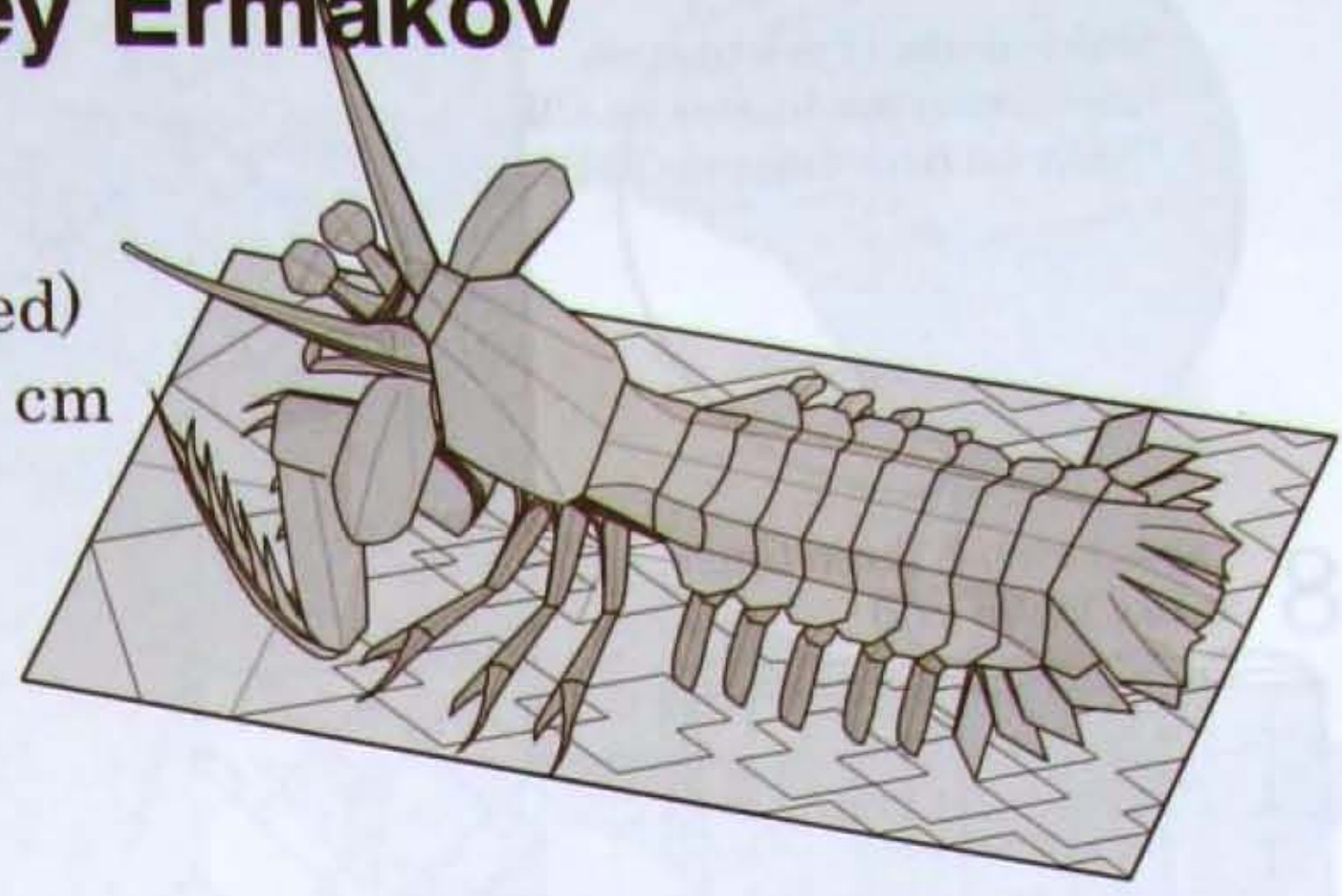

Crease Pattern

layer and a layer.

s.

9

make shape of orientation lines from coordinates on CP (looks on first diagram list)

8 repeat step 8 three times, make 96-96 grid

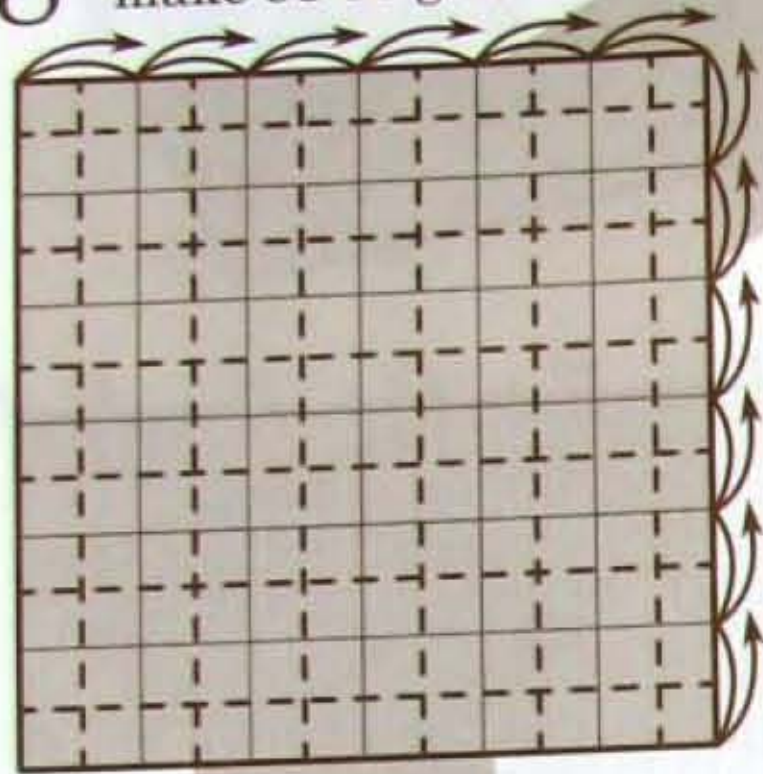

12-12

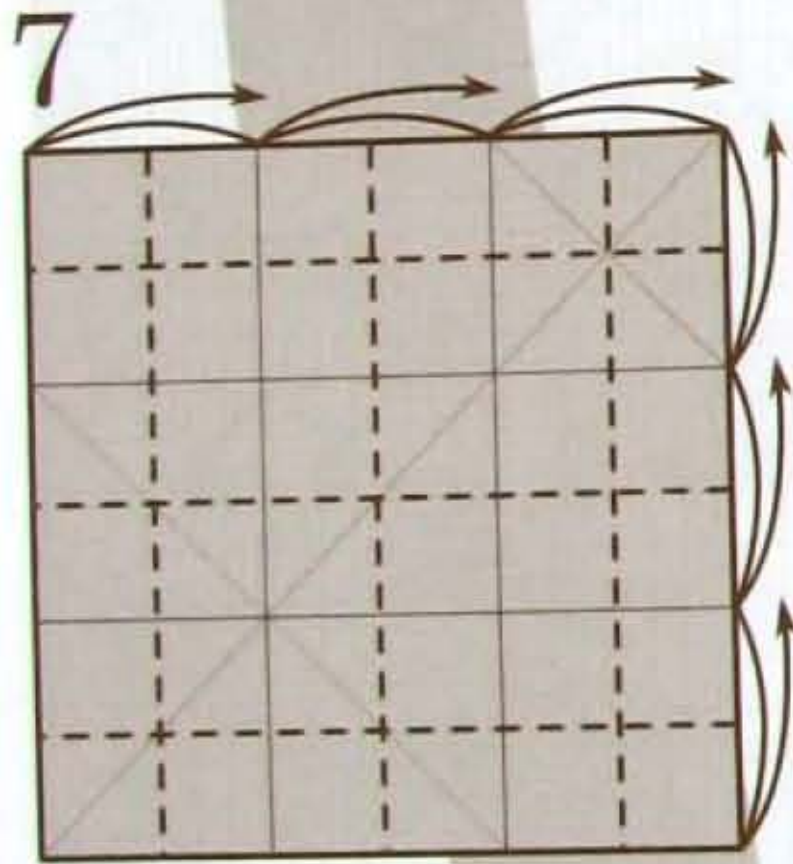

6-6

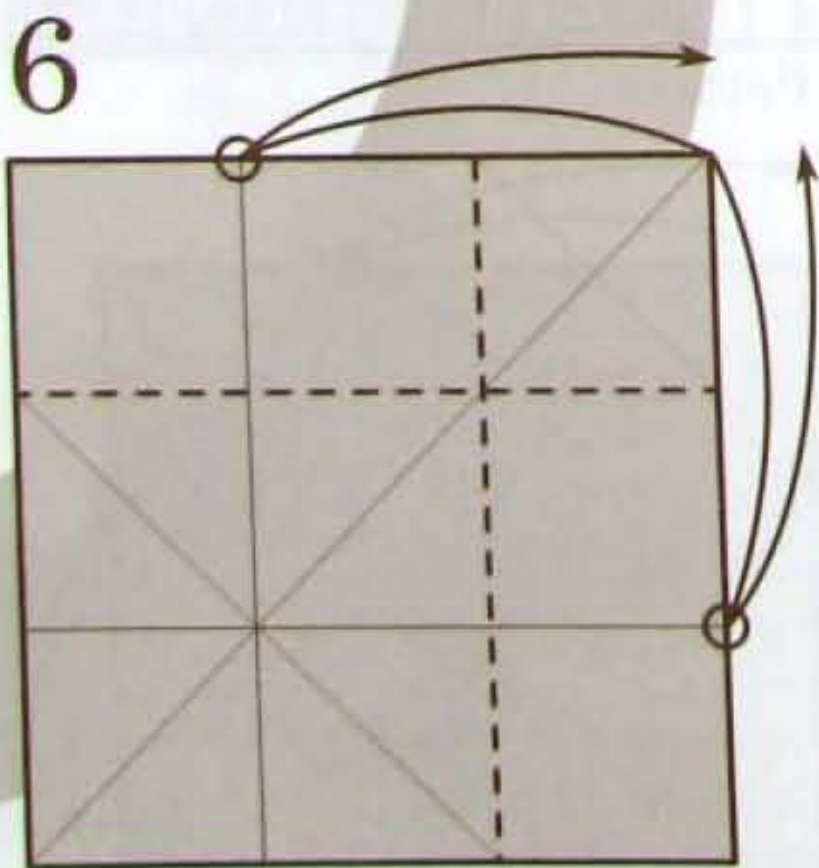

6

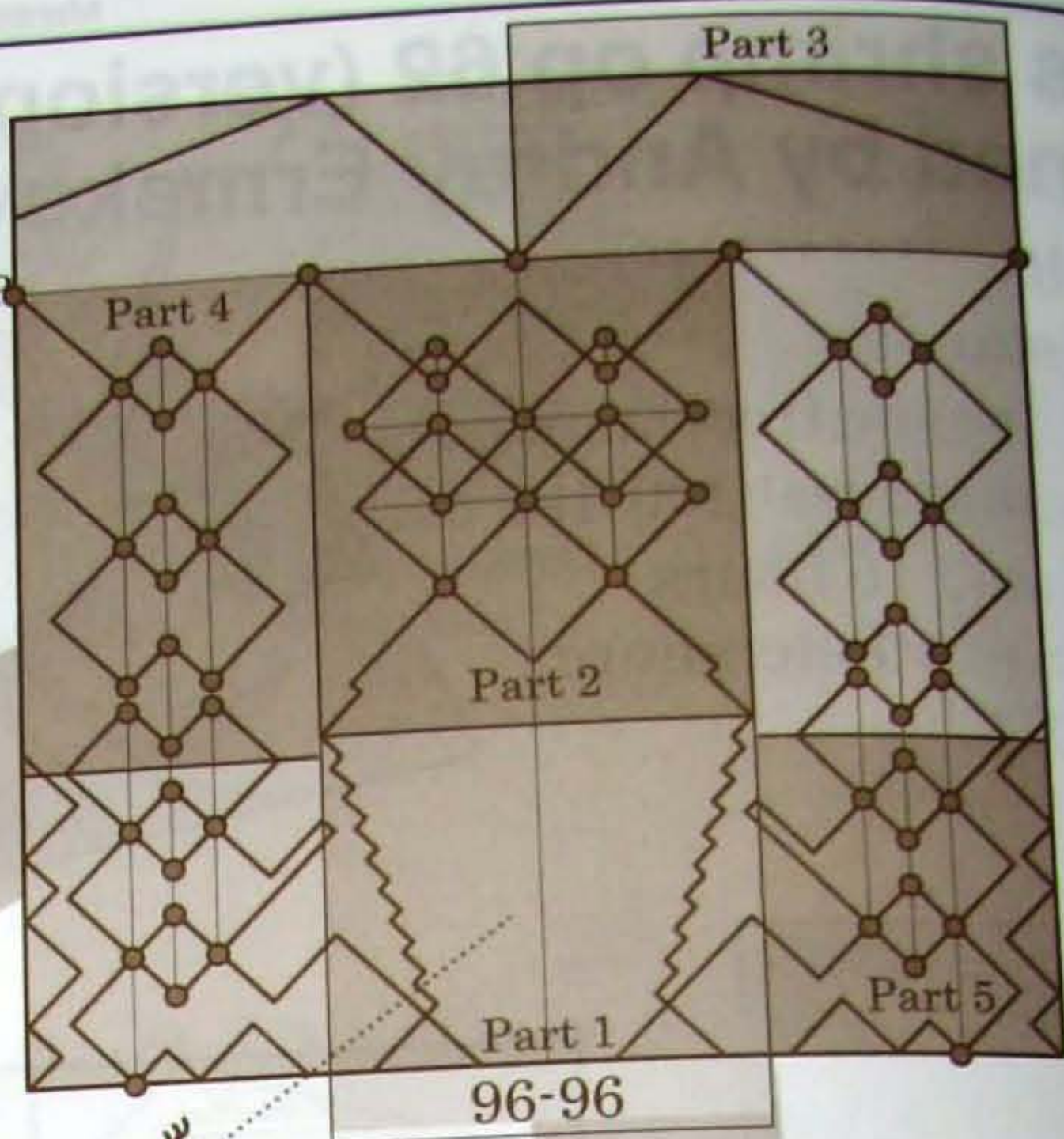

96-96

10

assemble using the existing crease lines

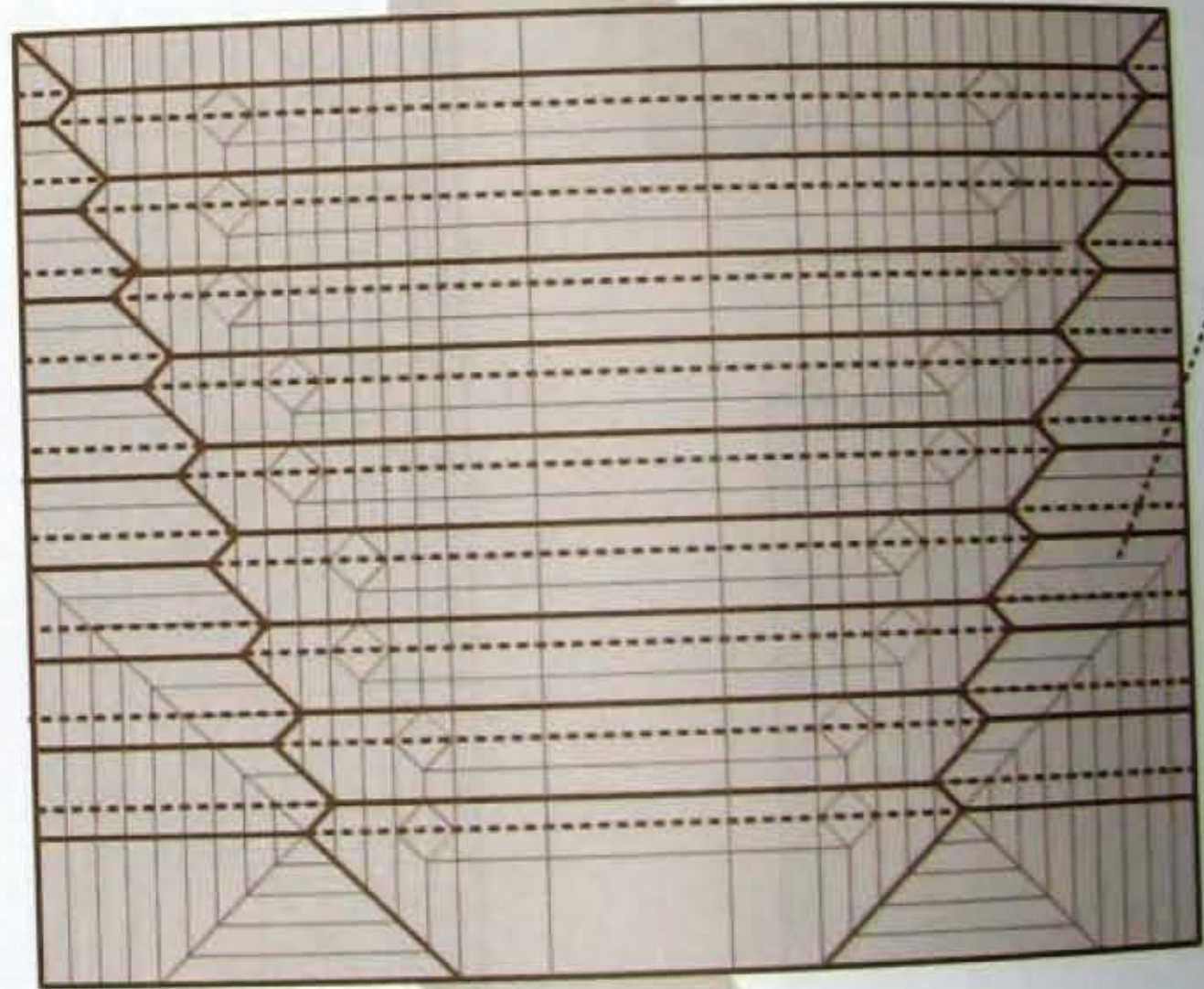

11

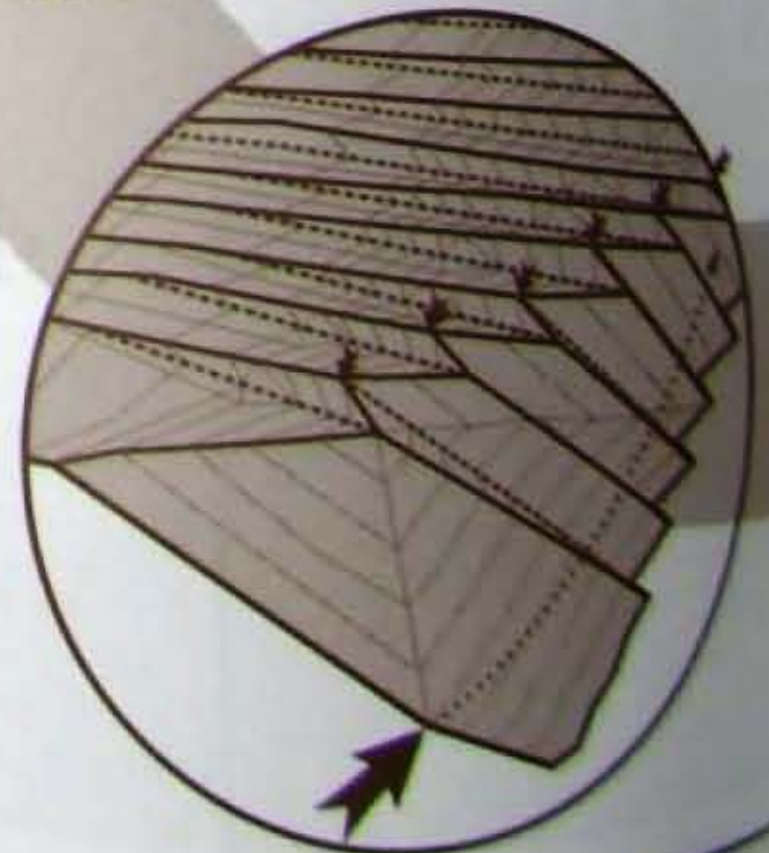

repeat 12-17 for rig

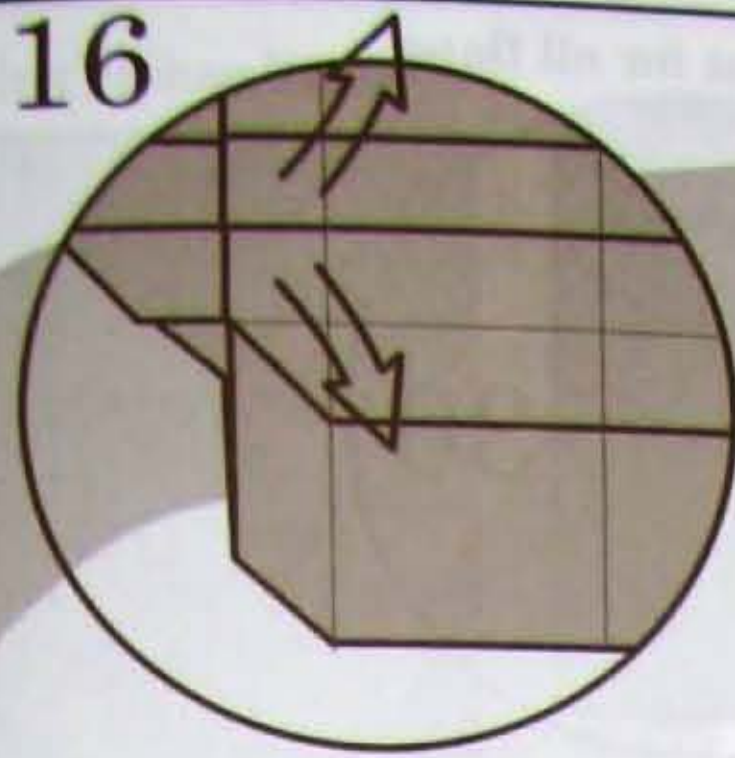
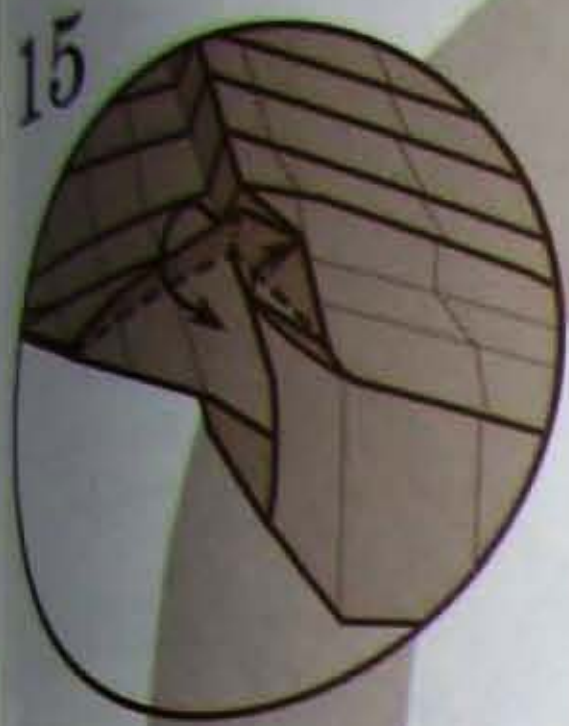

repeat steps 12-15

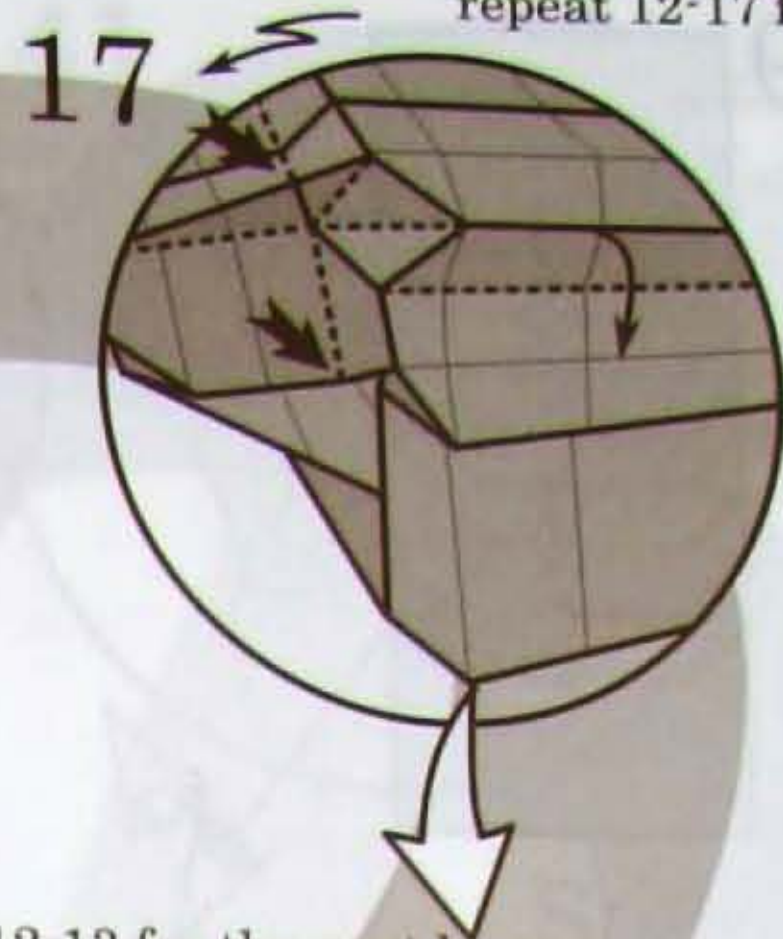

18 repeat 12-13 for the next layers

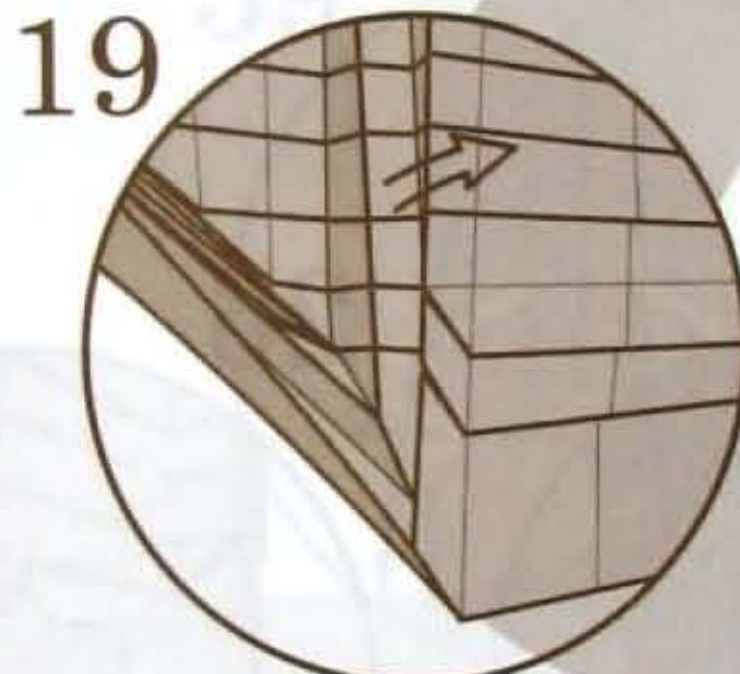
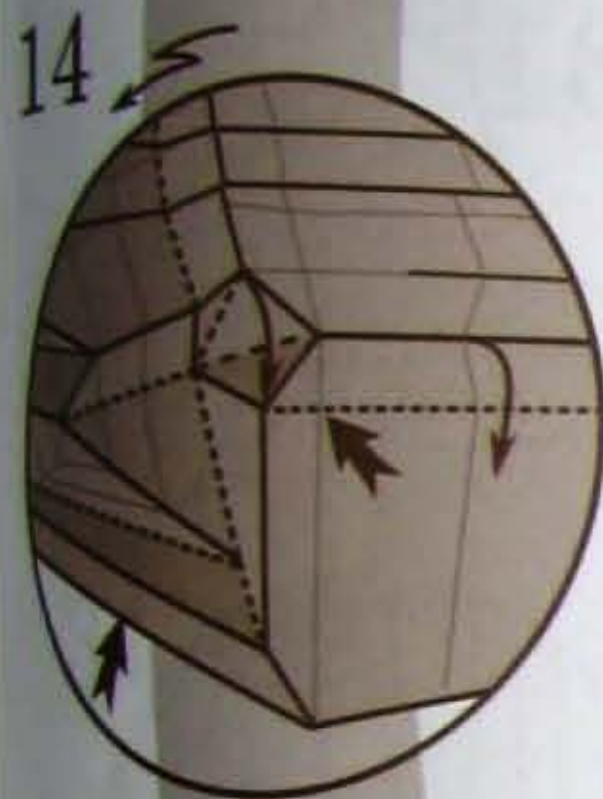
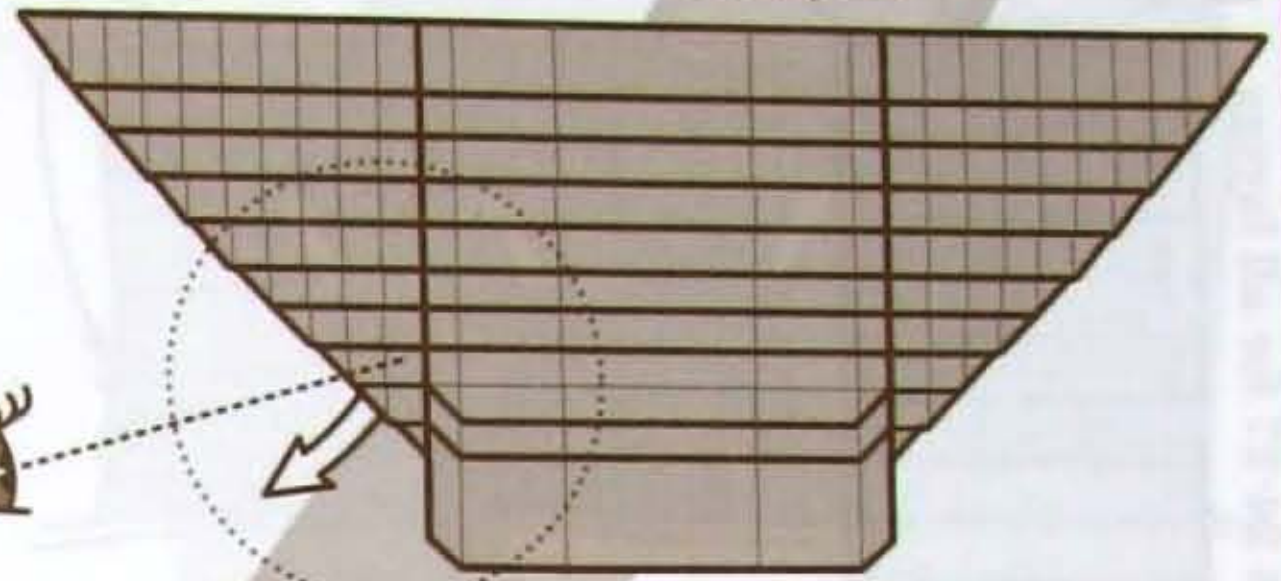

repeat steps 15-17



repeat for right half

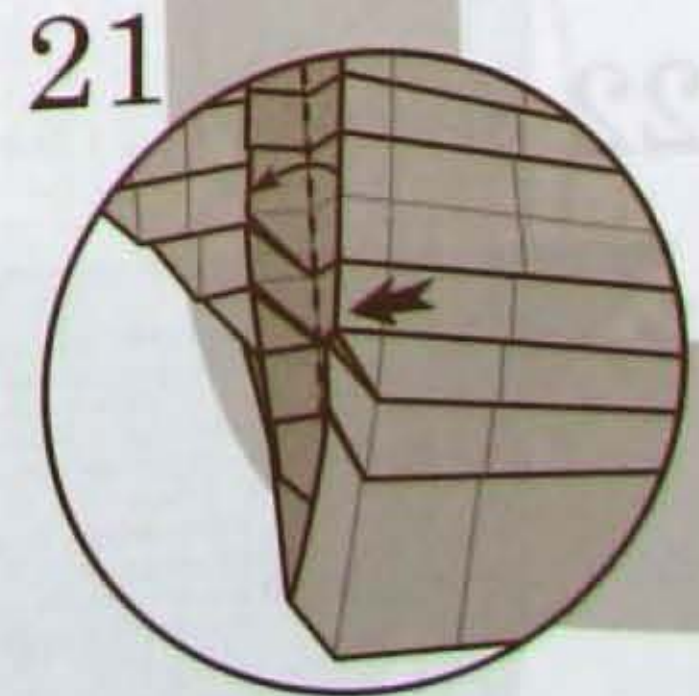
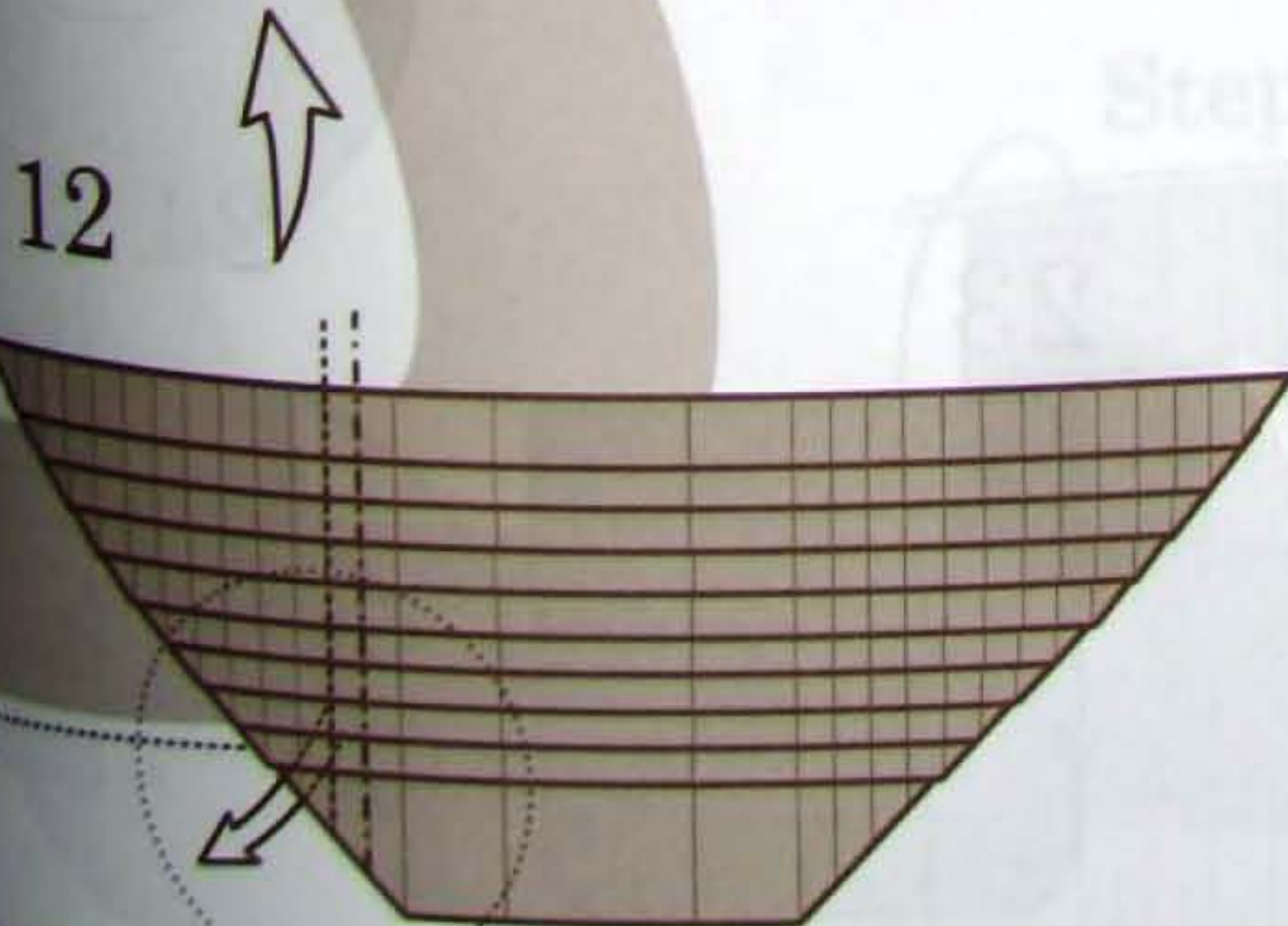
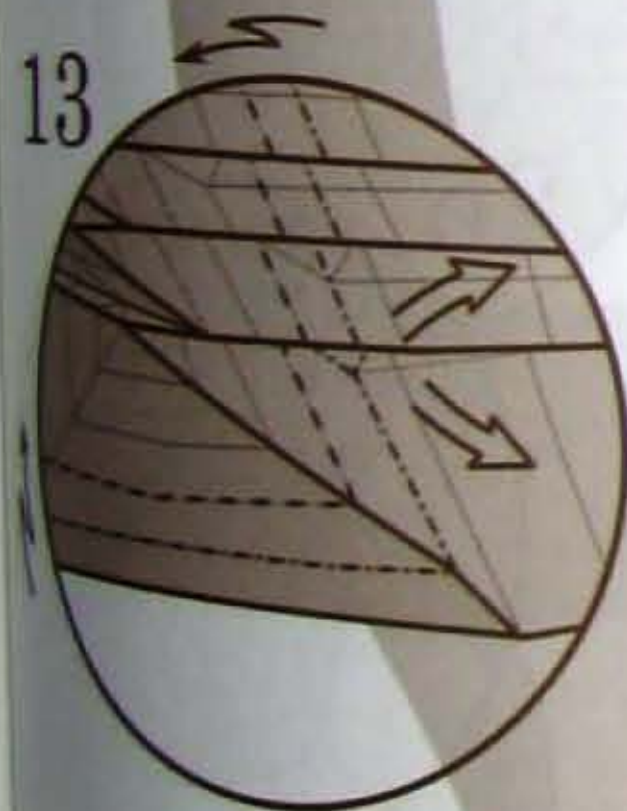

repeat for all flaps

29

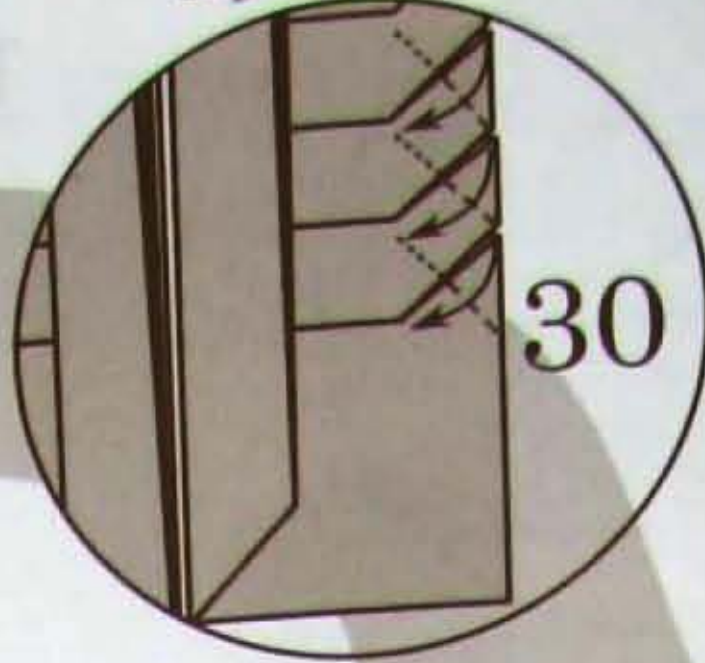
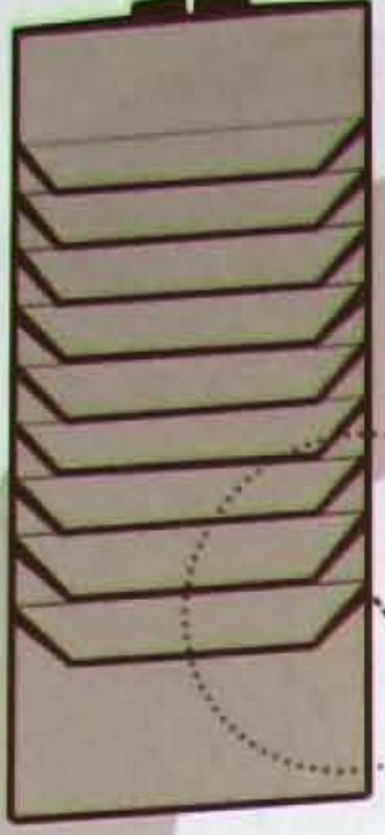

30

32



1 Part completed

28

repeat 24-27 for all layers

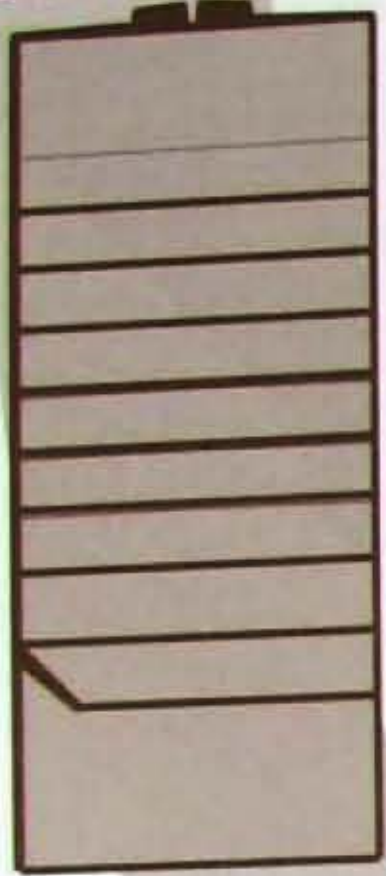

27

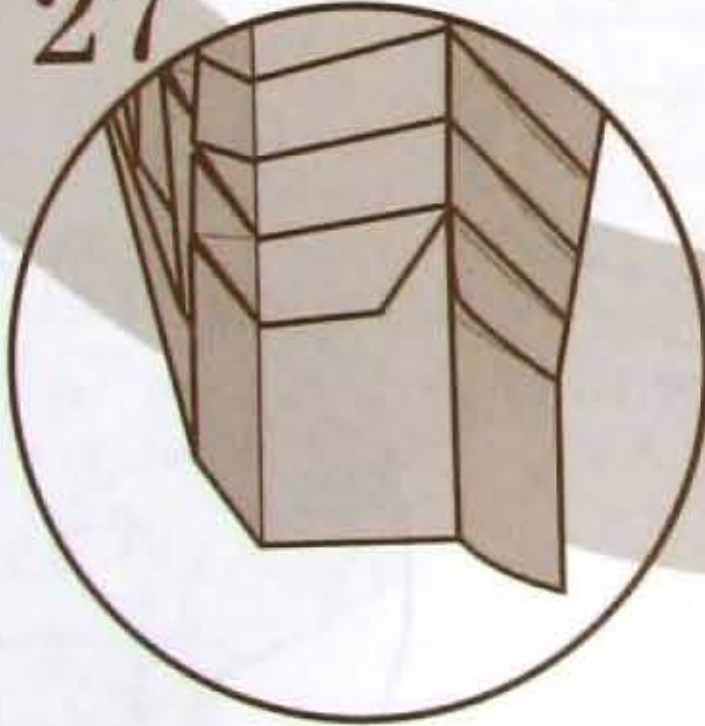

26

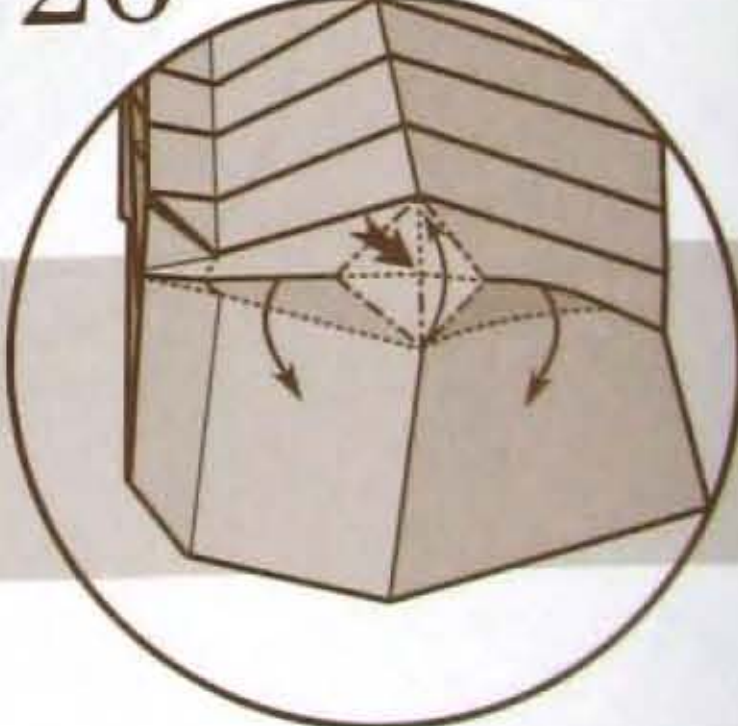

25



22

repeat steps 12-21 for all layers

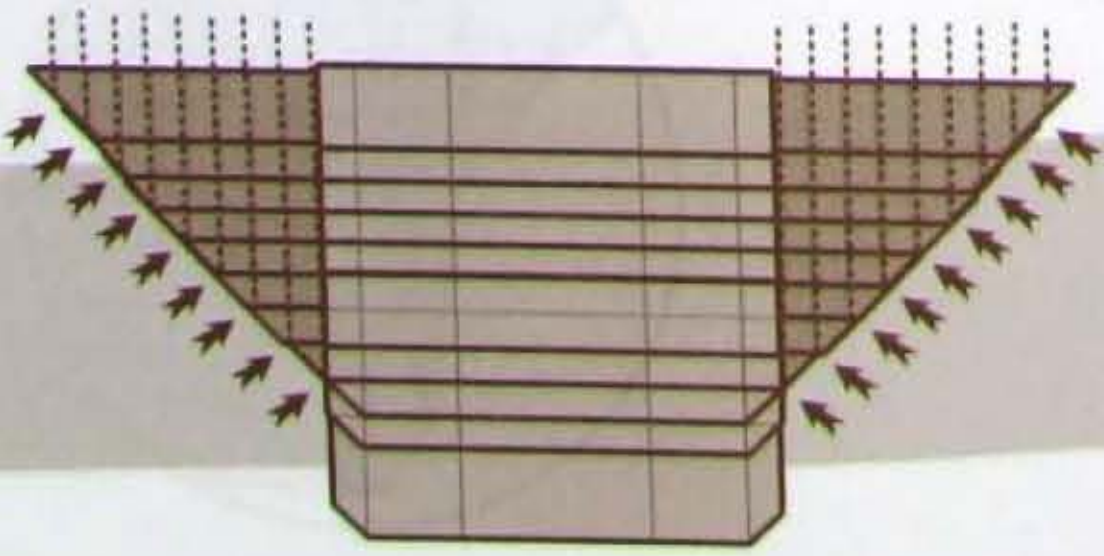

23

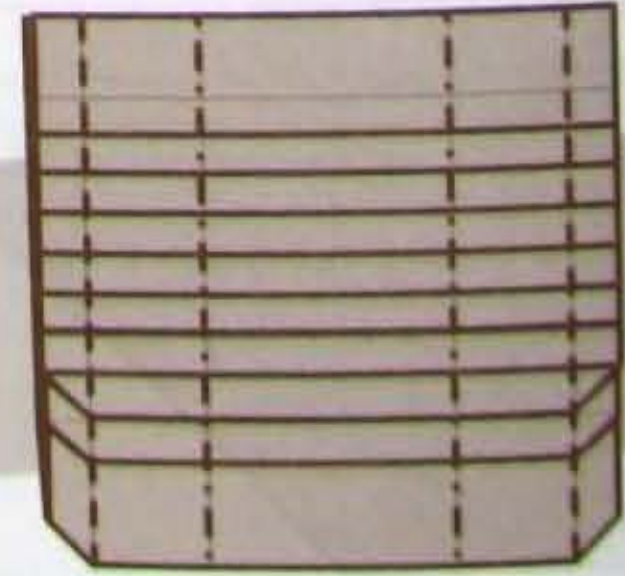

24



assemble using the existing crease lines

Step 2.3

Step 2.2

Step 2.1

part 2

34

35

36

41

using the crease lines

40

Step 2.2

39

38

Step 2.1

37

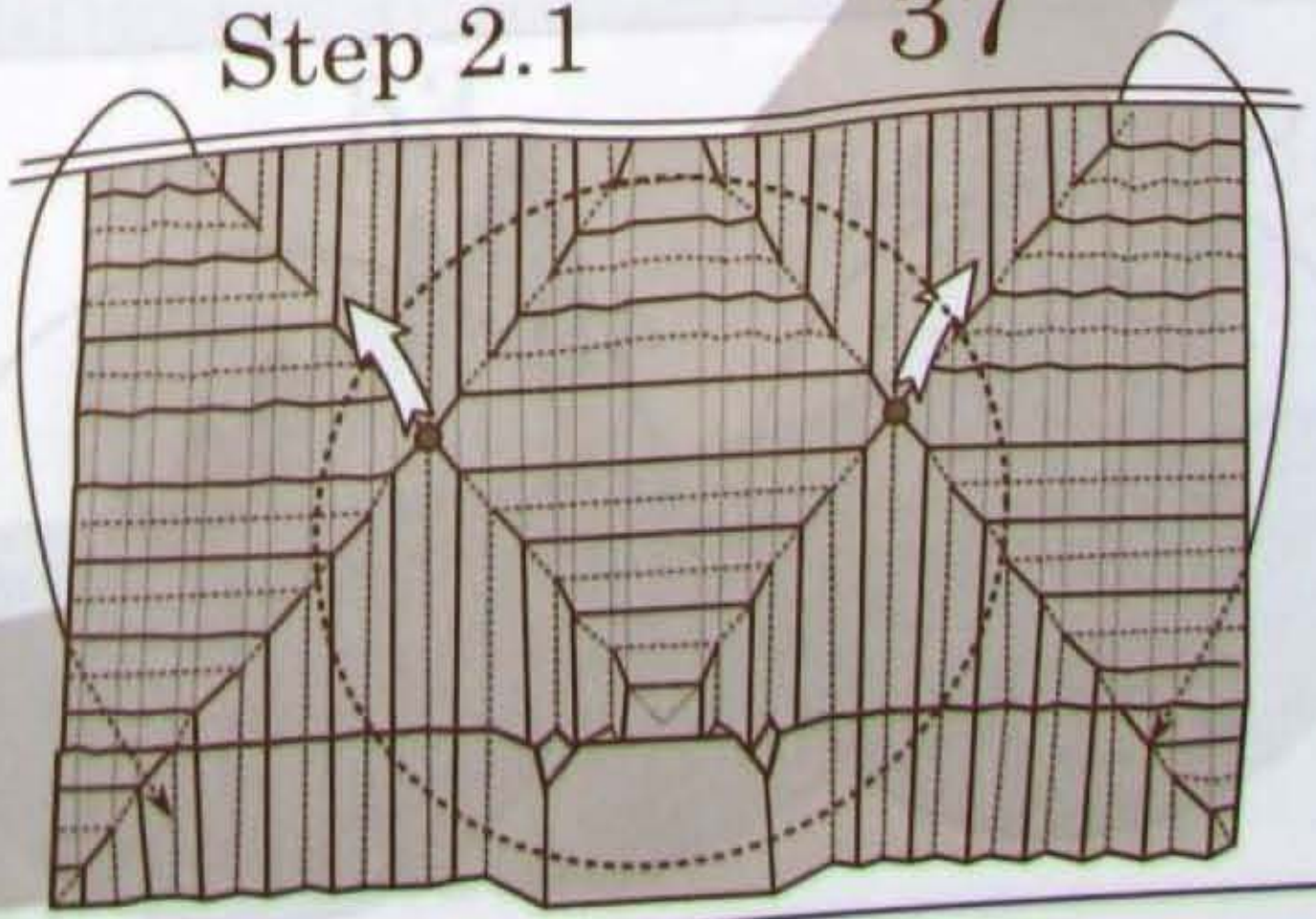
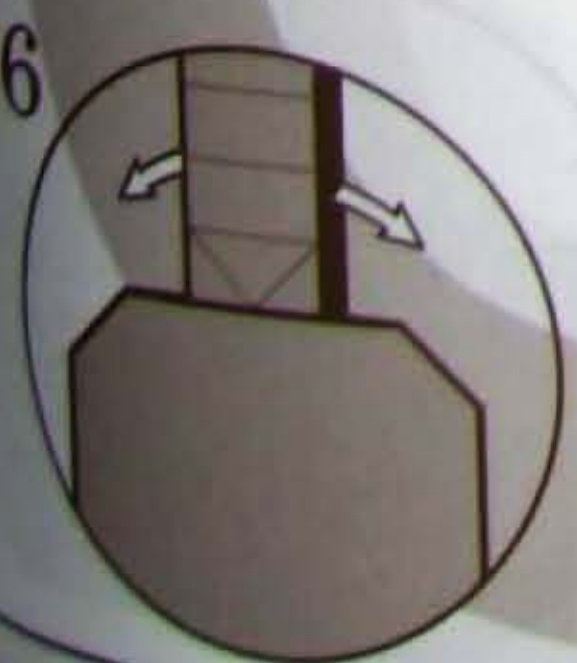
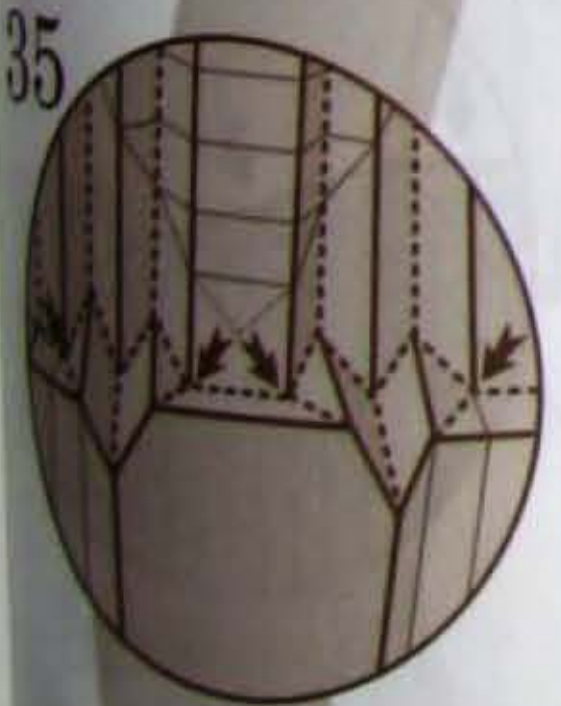
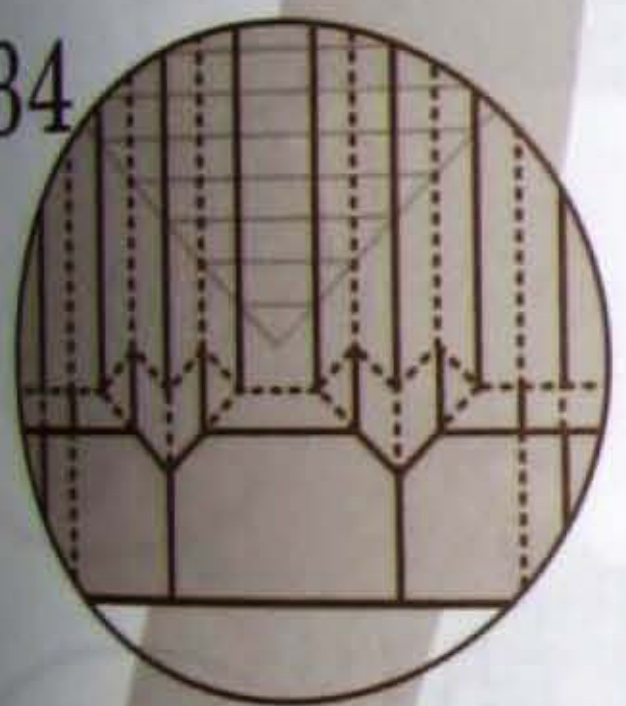
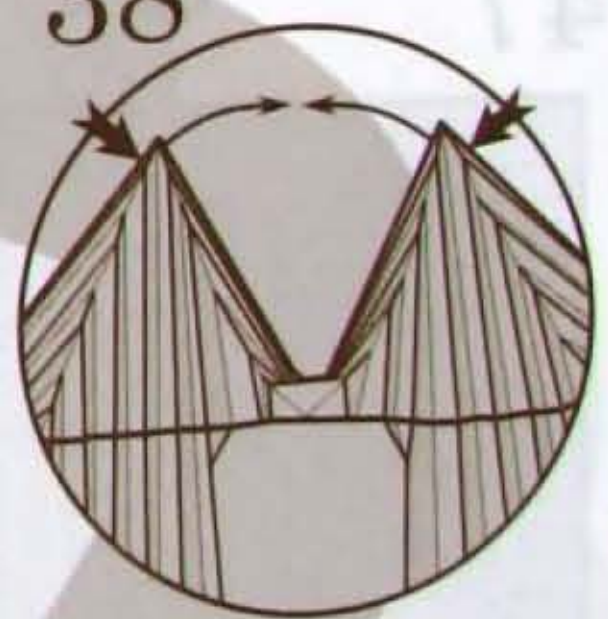
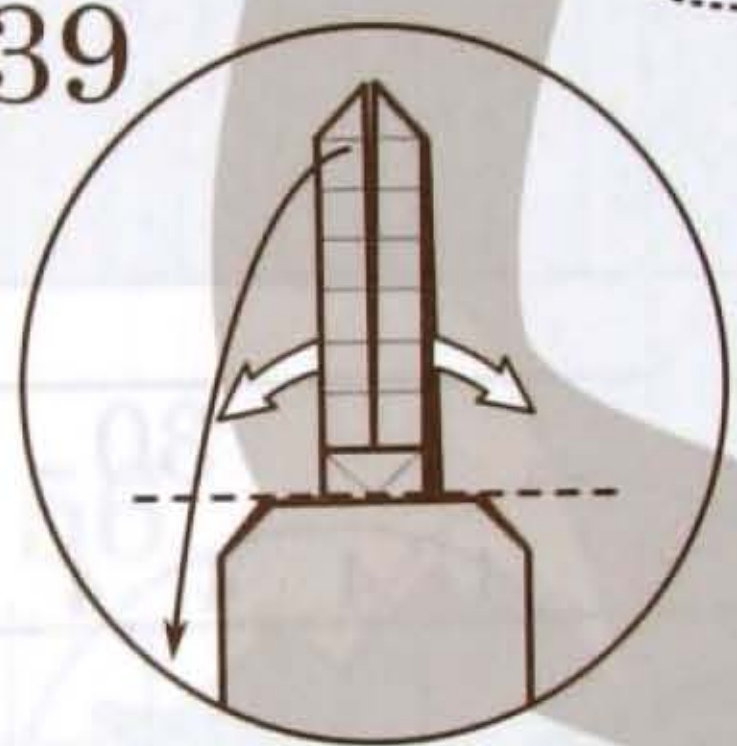
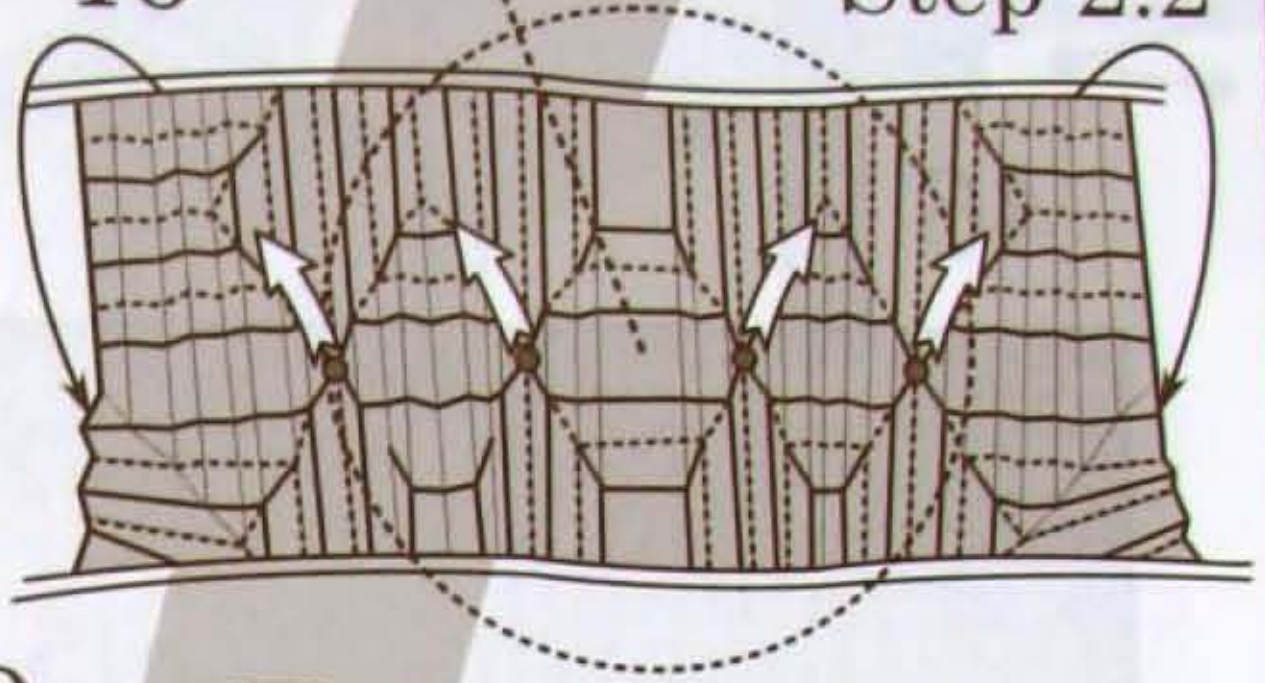
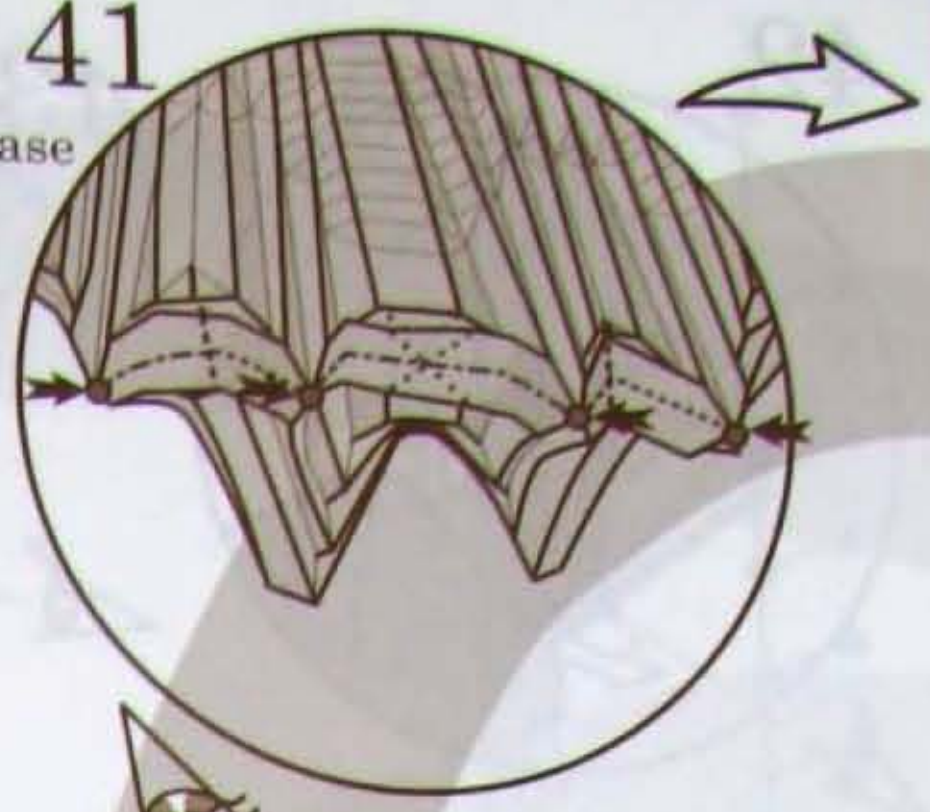
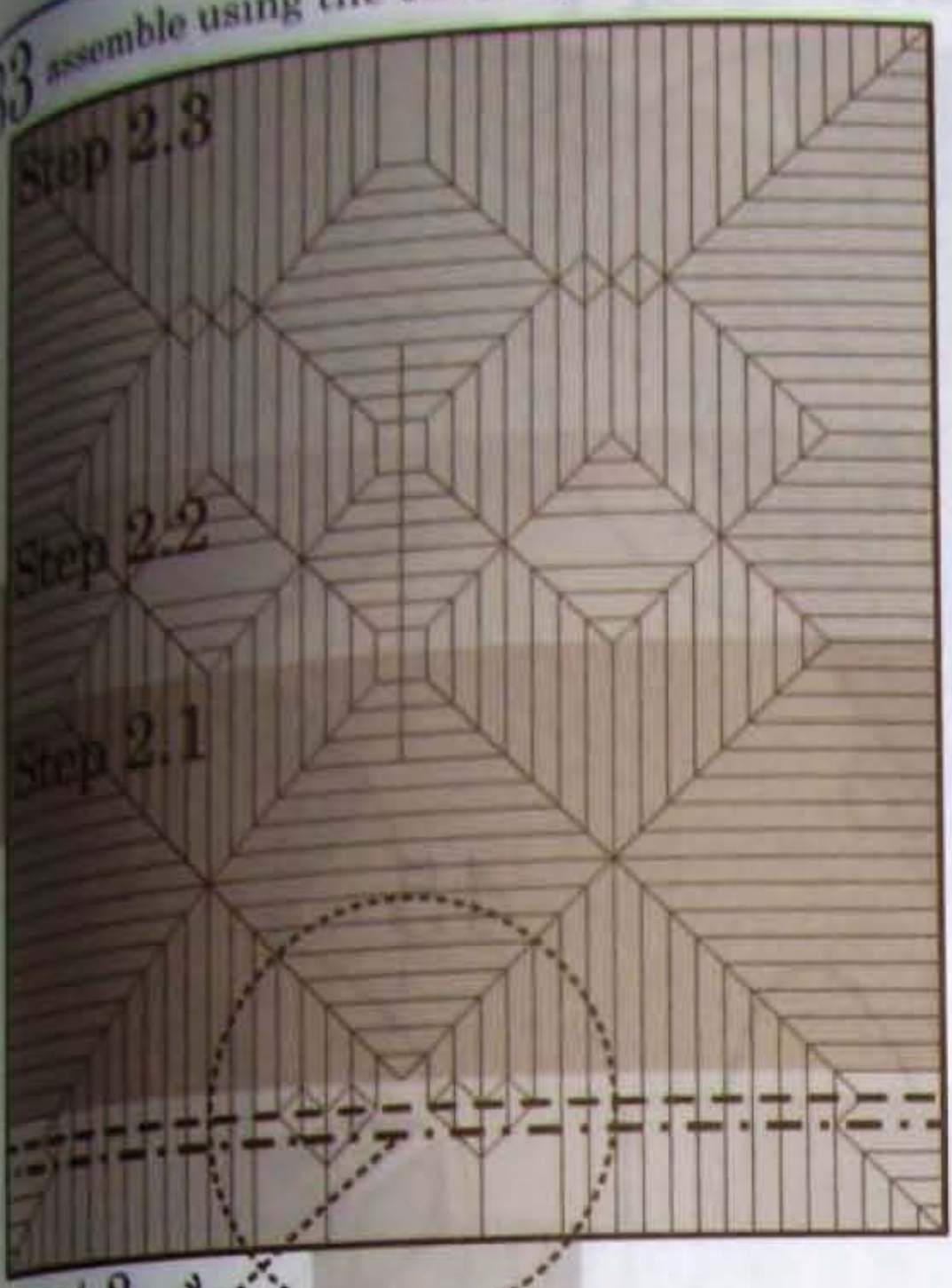

Step 2.3

44

42

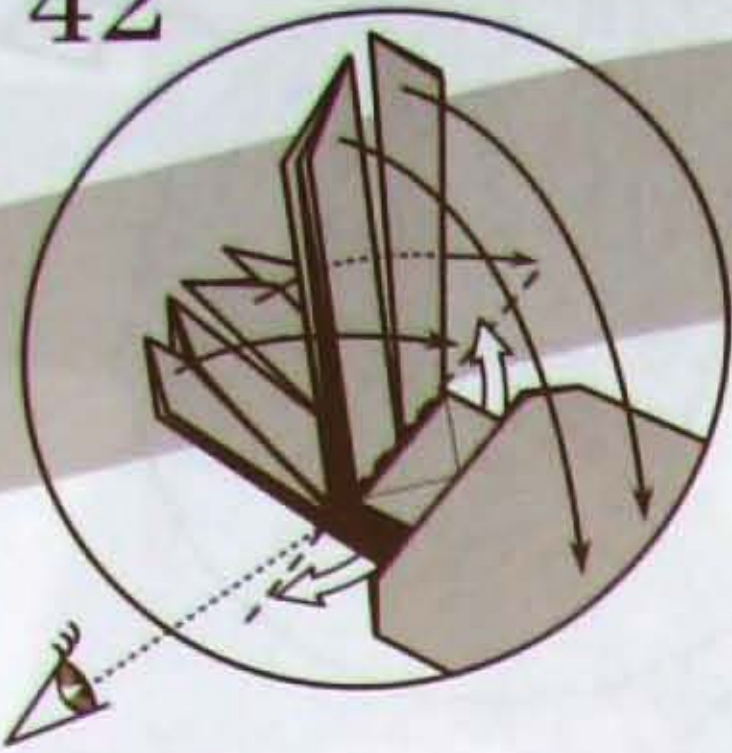

43

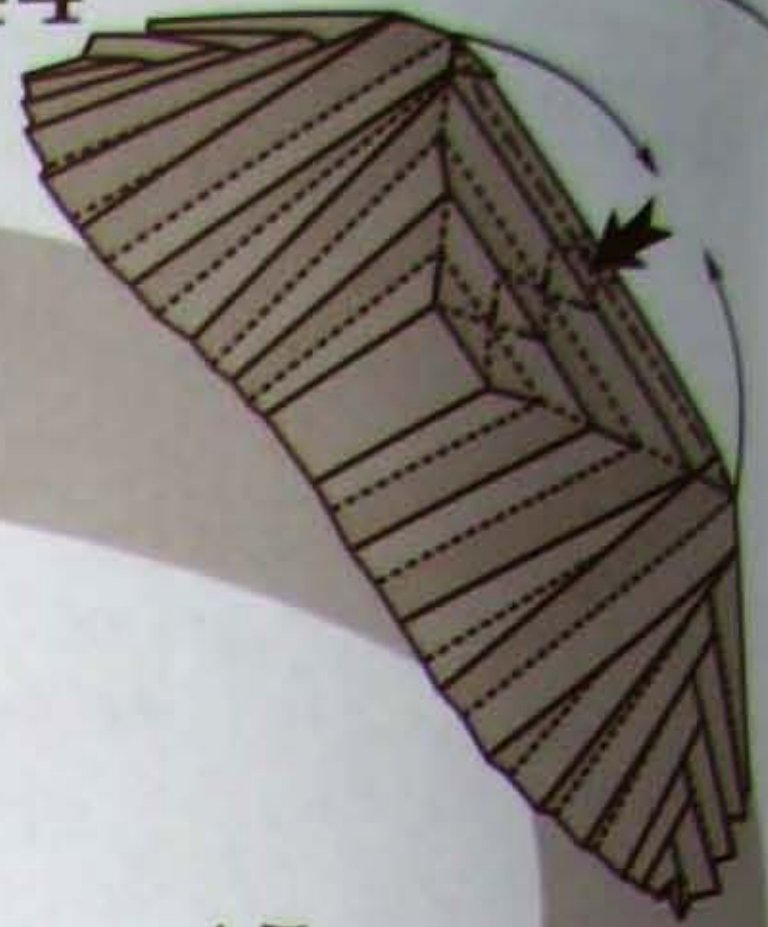
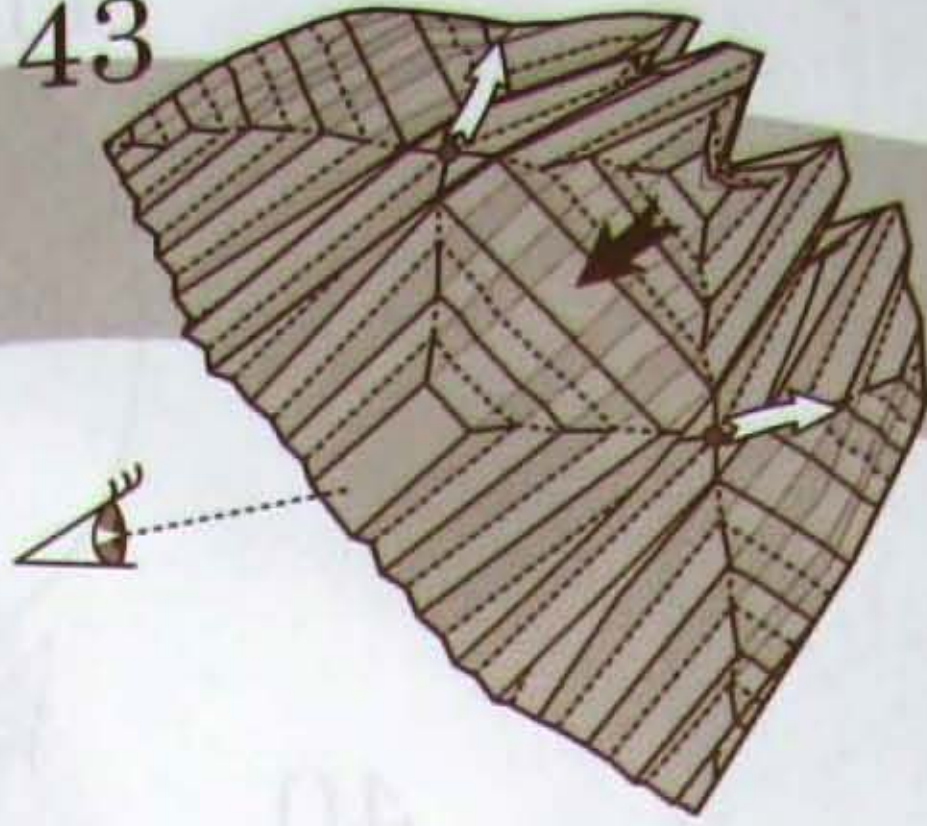

46

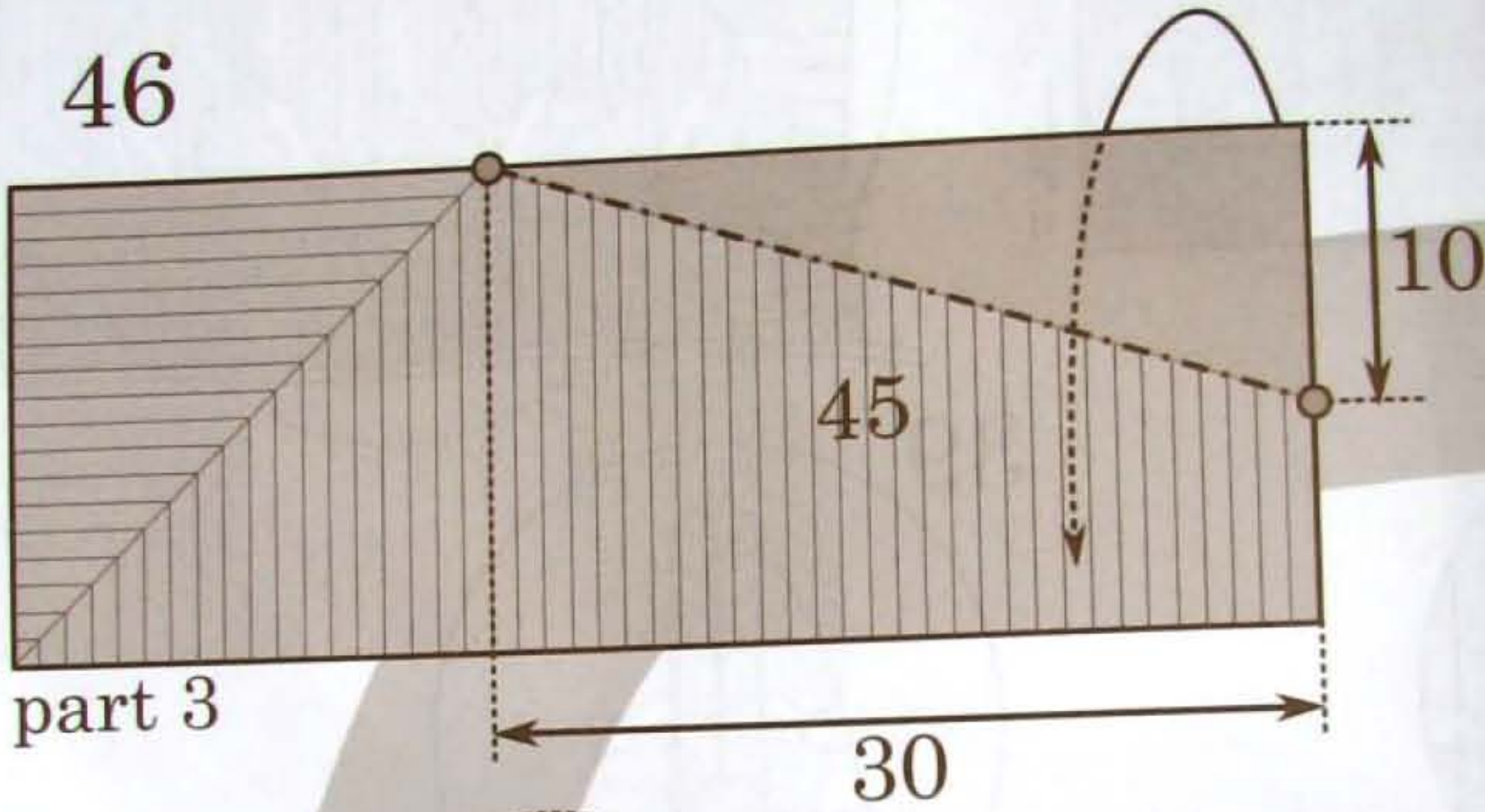

45

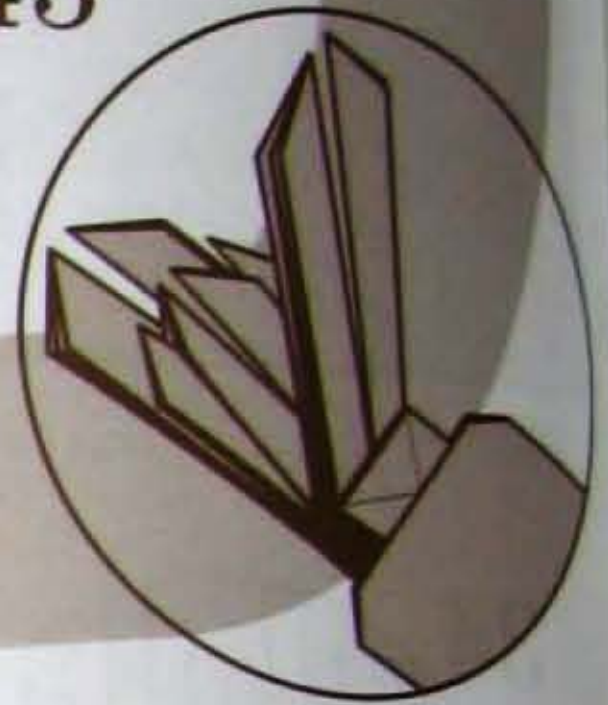

47

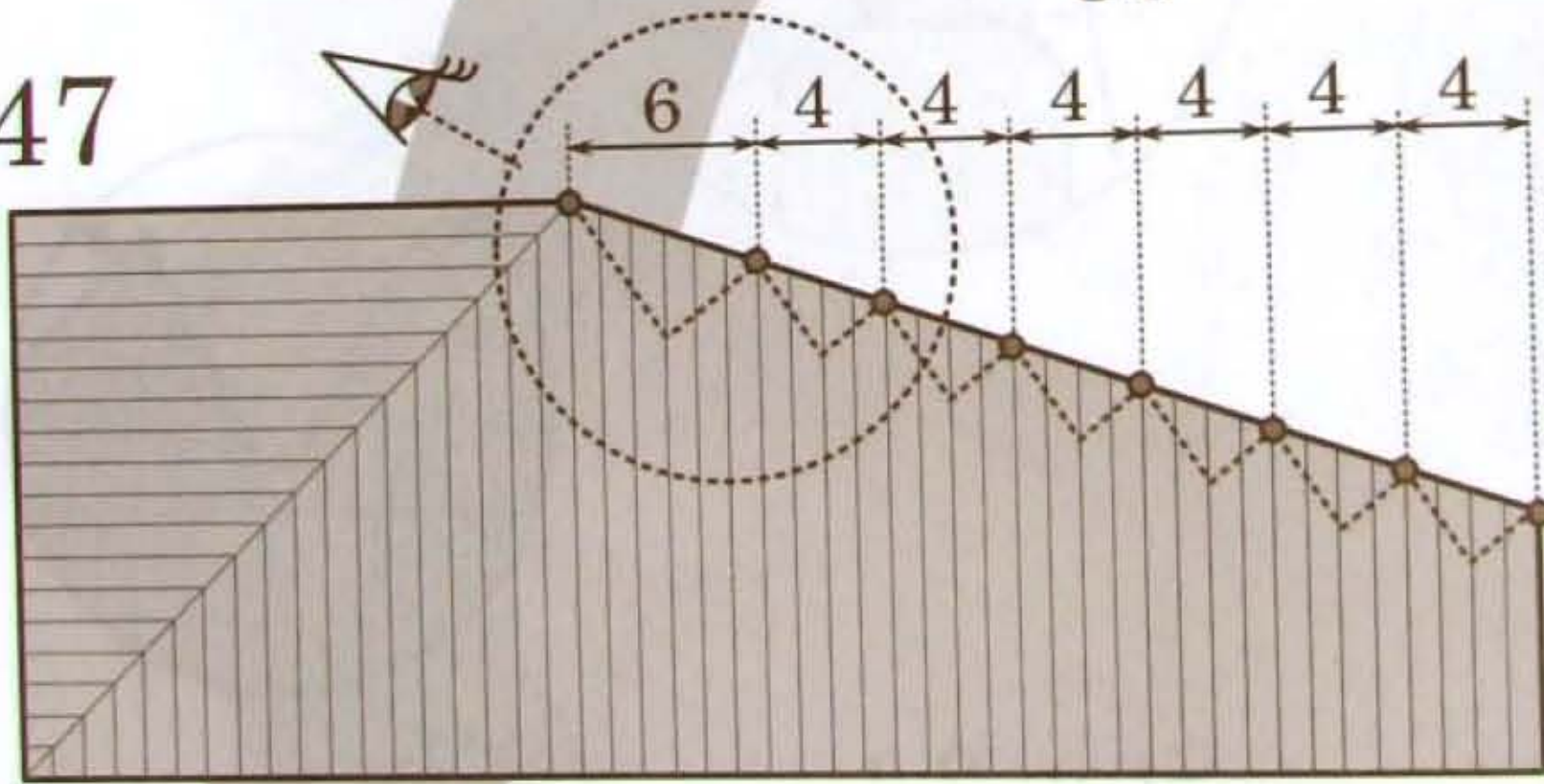

51



Part 2 completed

48

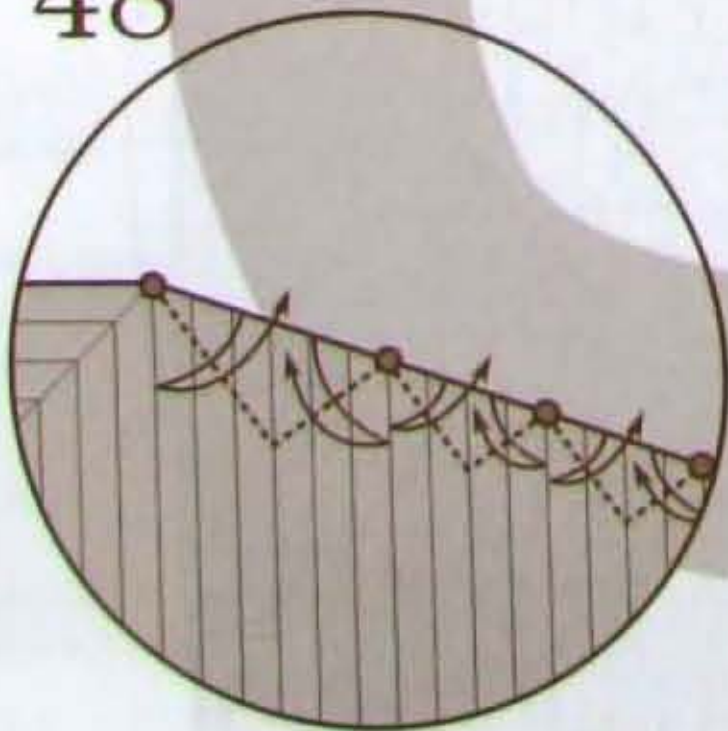

49

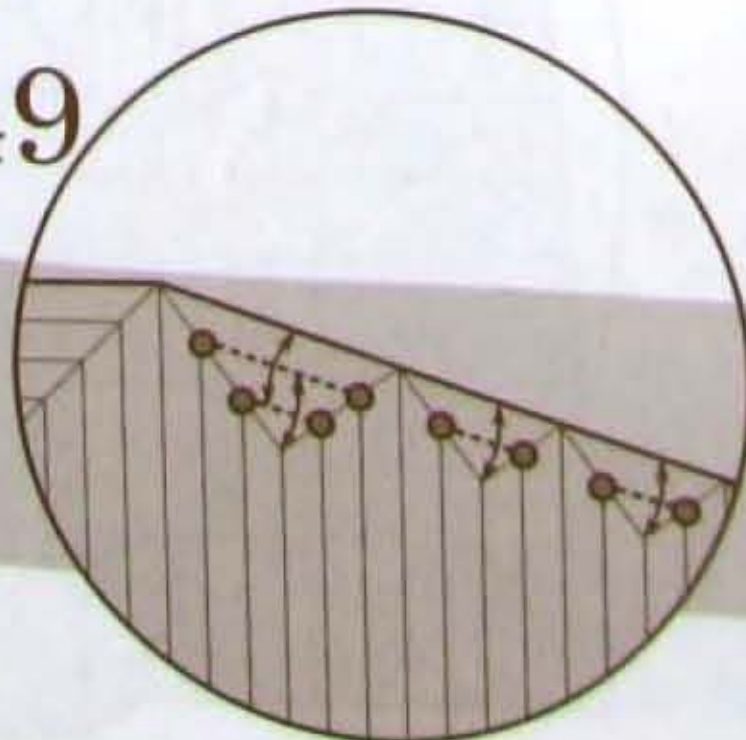

50

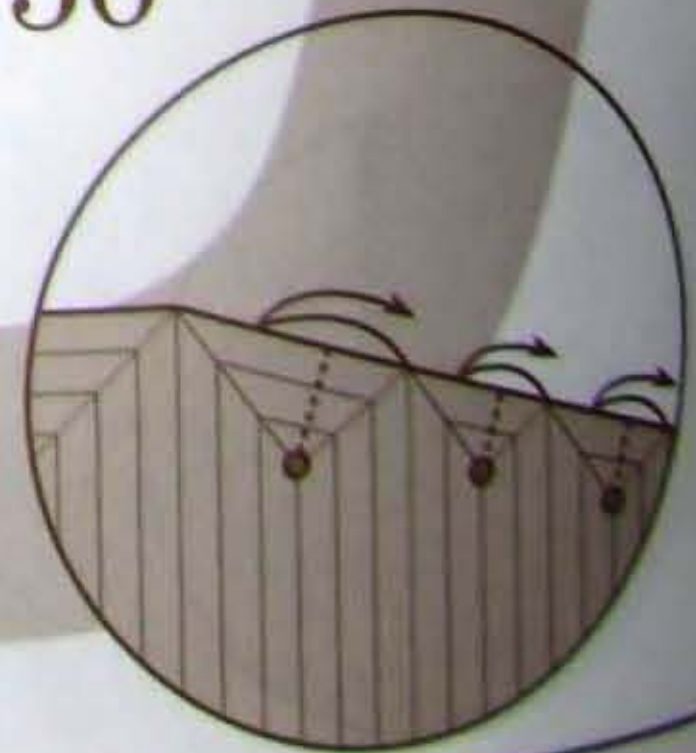

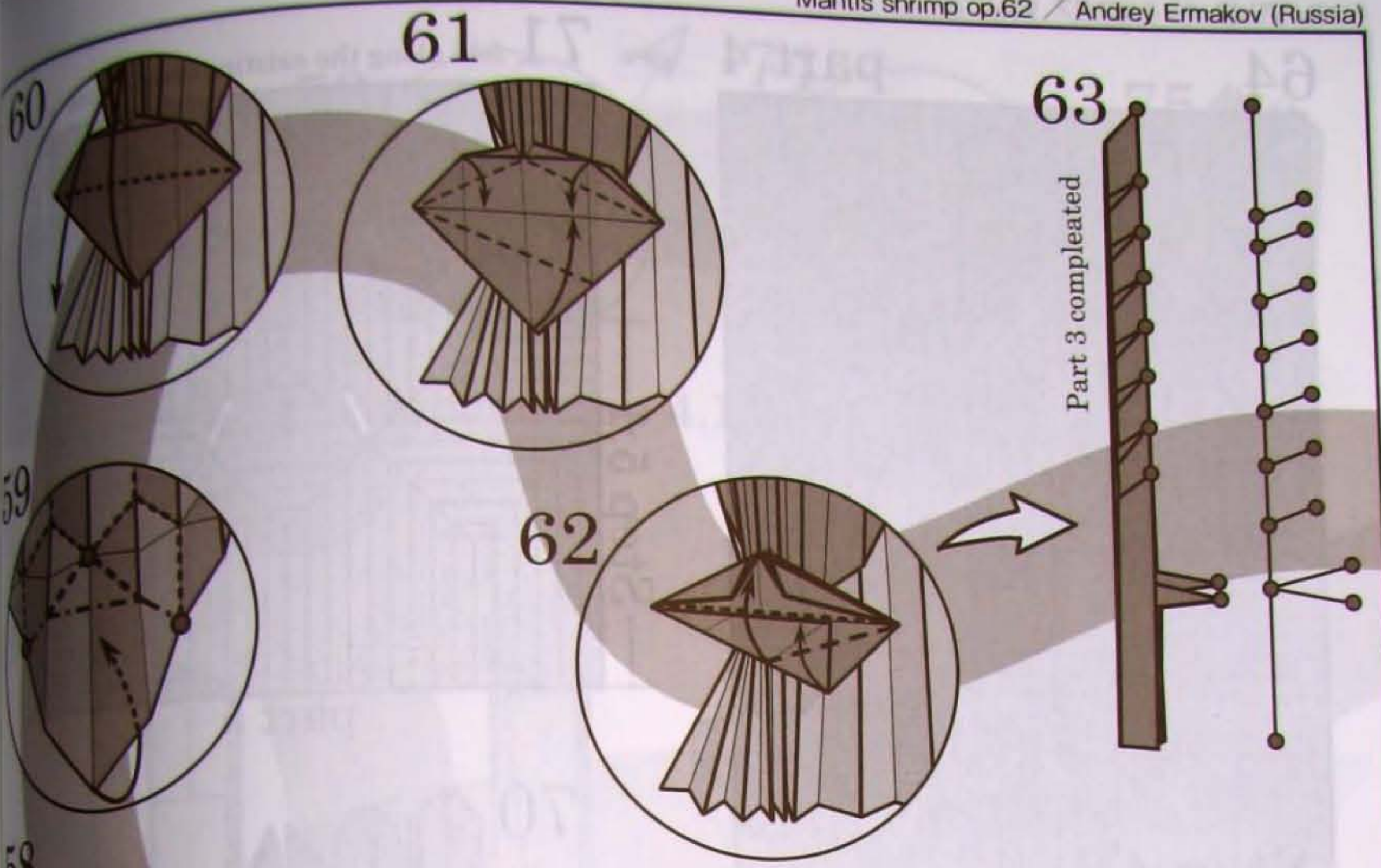

Japão Burajirujin

www.japaoburajirujin.blogspot.com

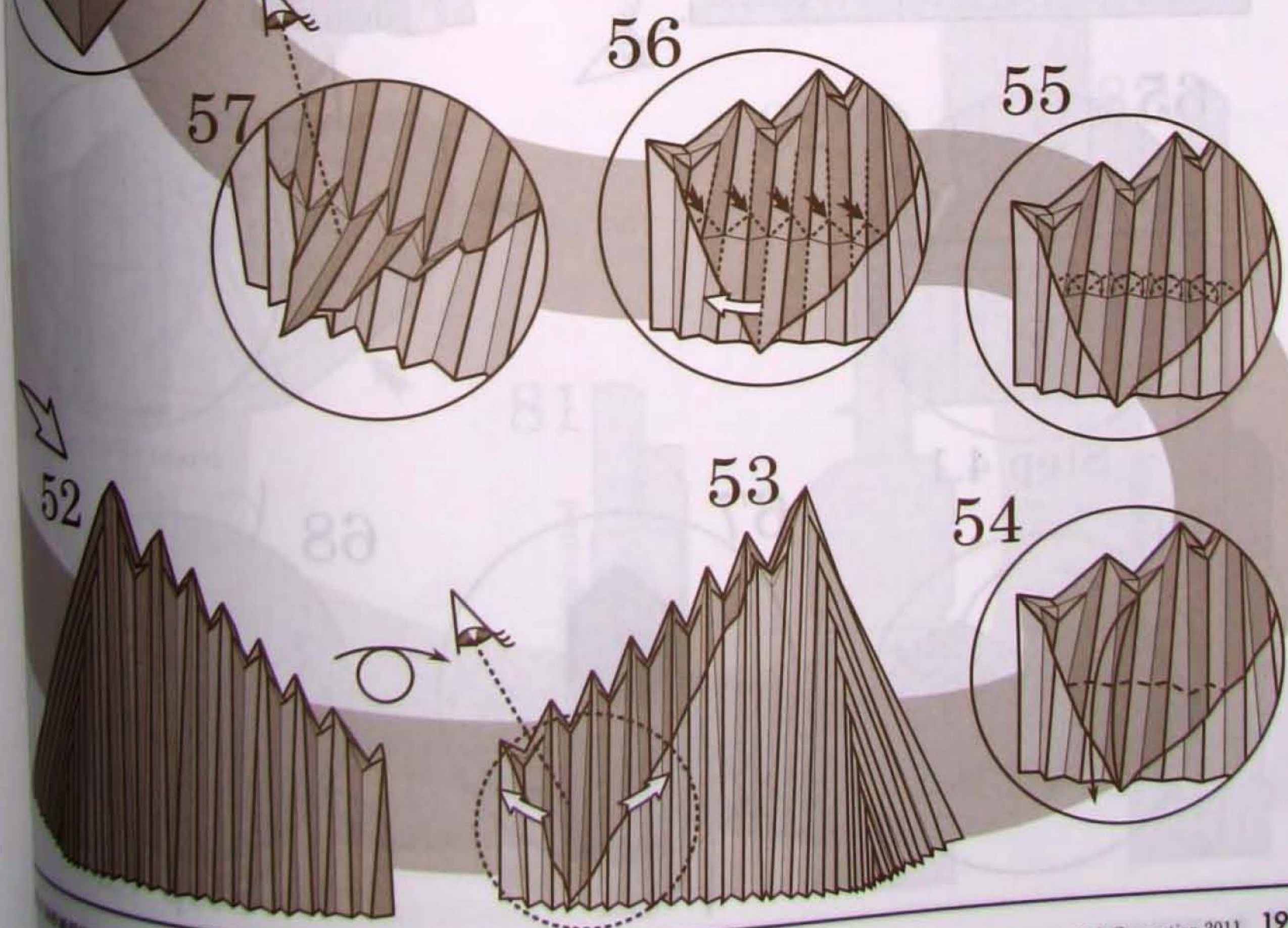

64

part 4

Step 4.3

Step 4.2

Step 4.1

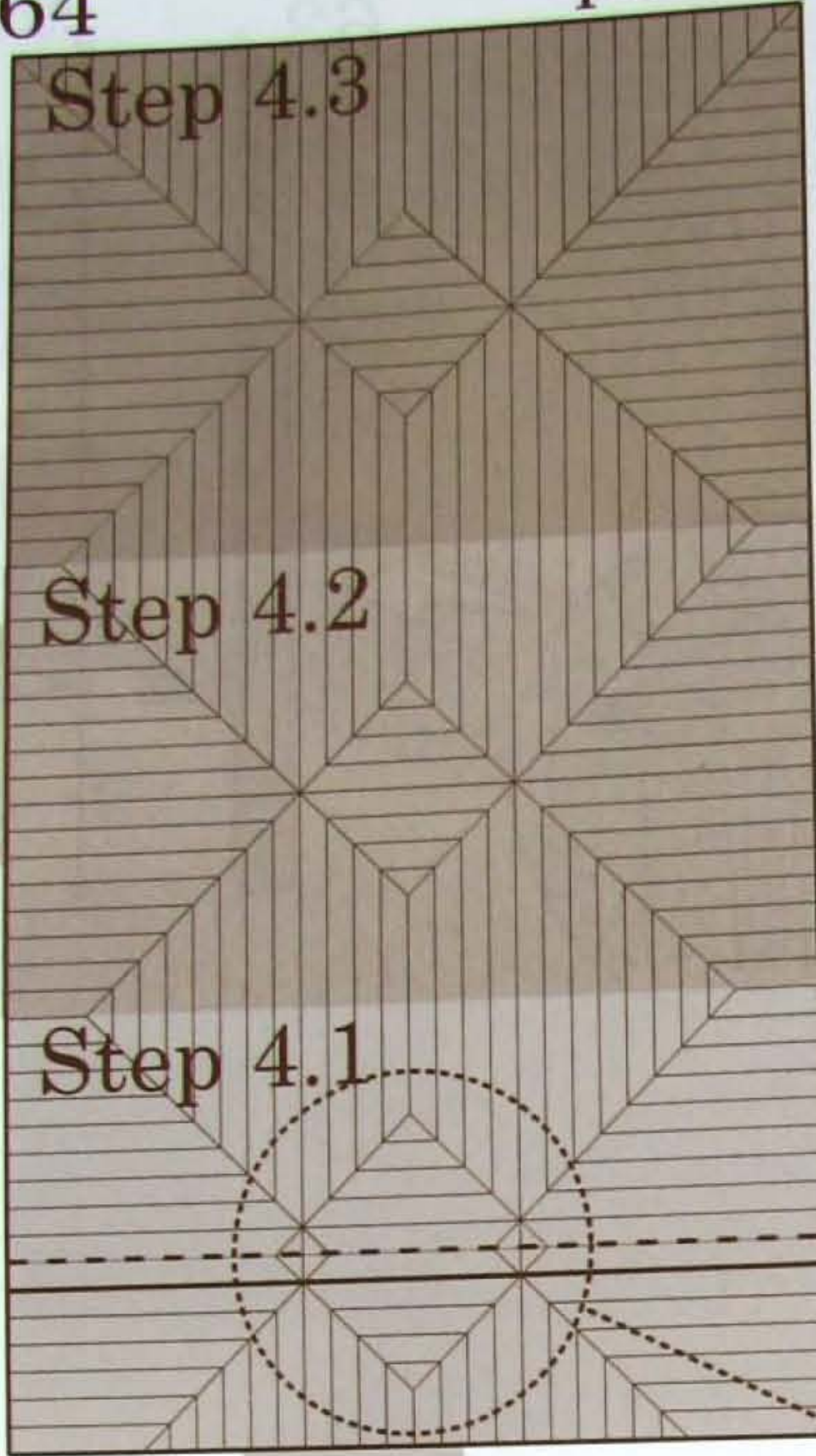

71 fold along the existing crease lines

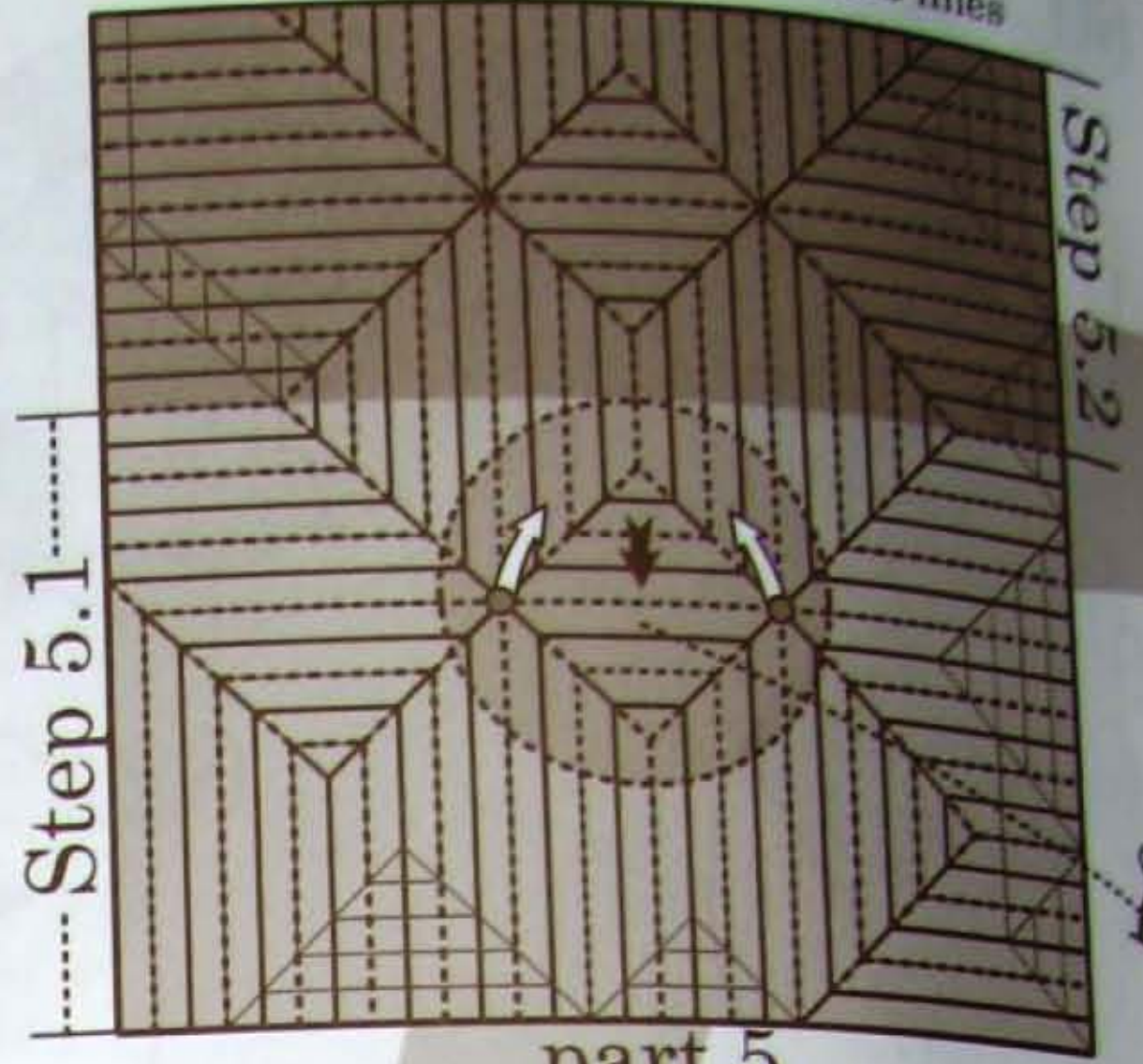

Step 5.1

Step 5.2

part 5

70

Part 4 completed



65

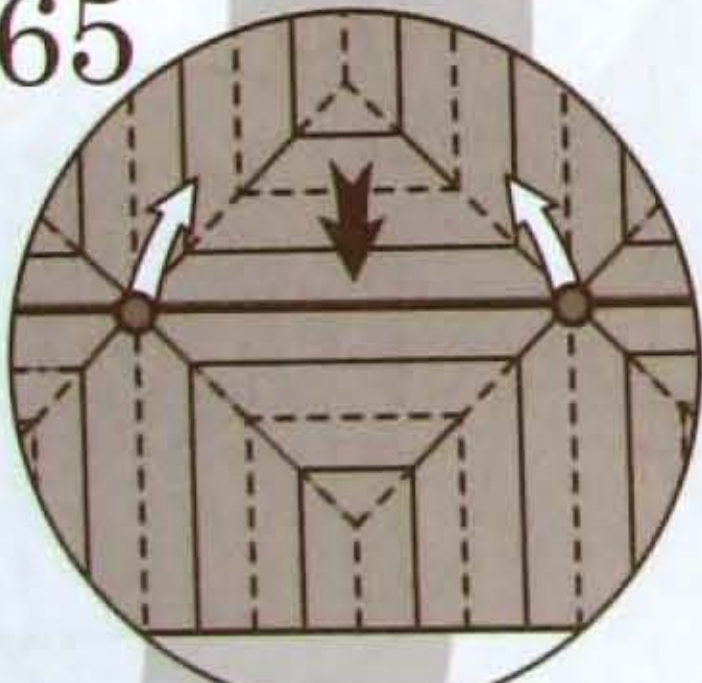

Step 4.1

69



repeat 65-67 for step 4.1

66



67

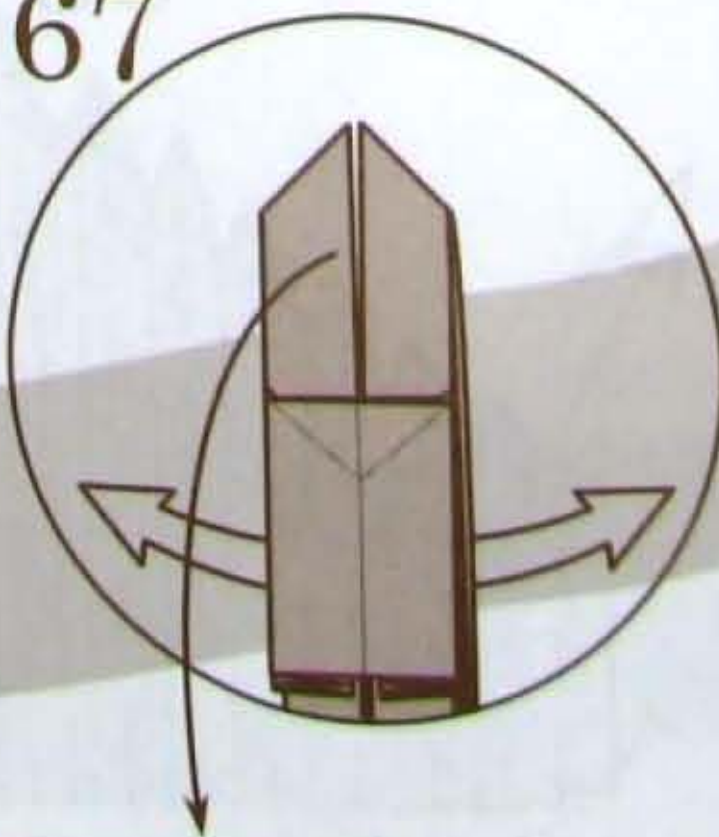

68



Step 4.2



Step 5.1

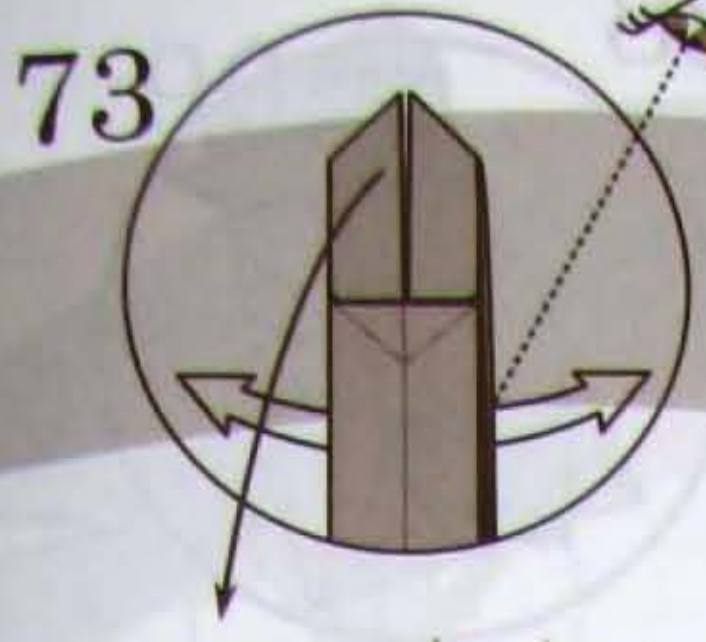

repeat step 4.1



Step 5.2

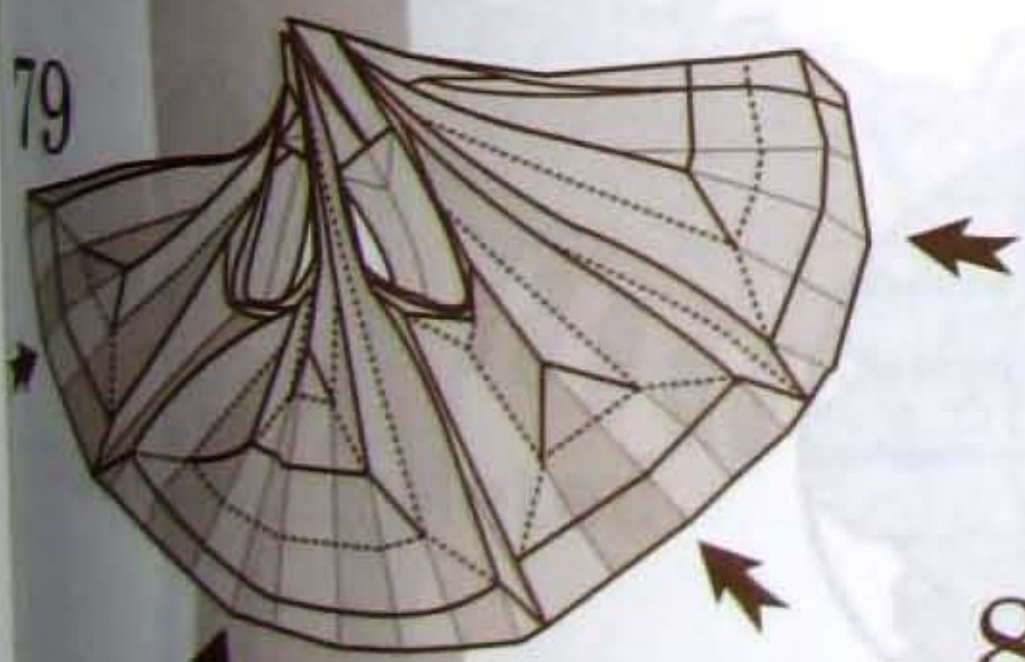
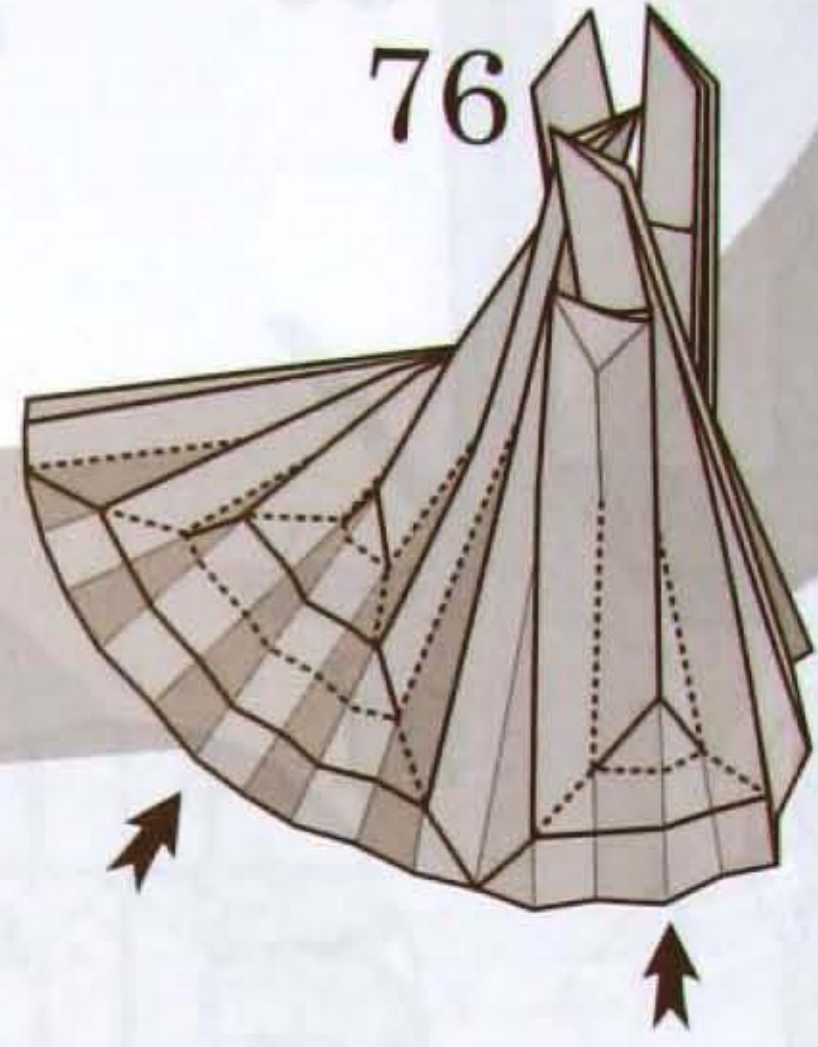
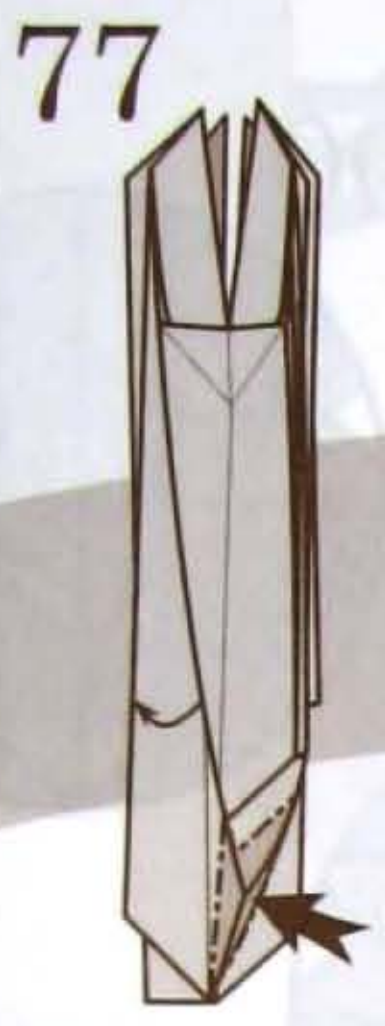
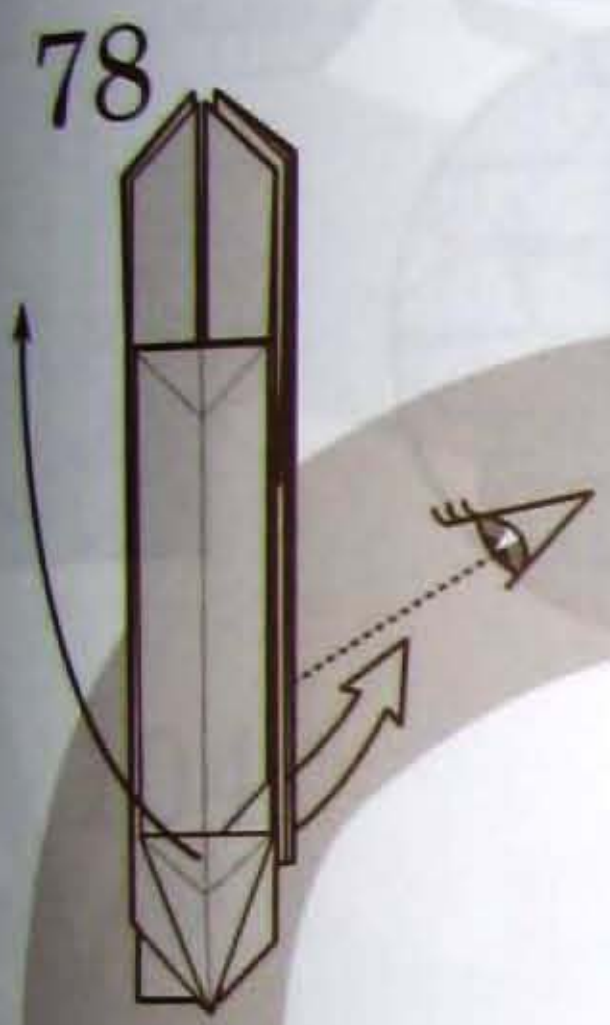
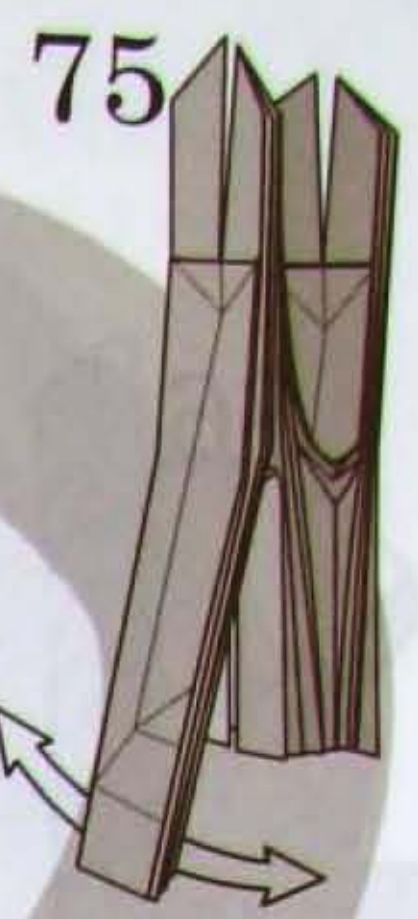

All parts completed

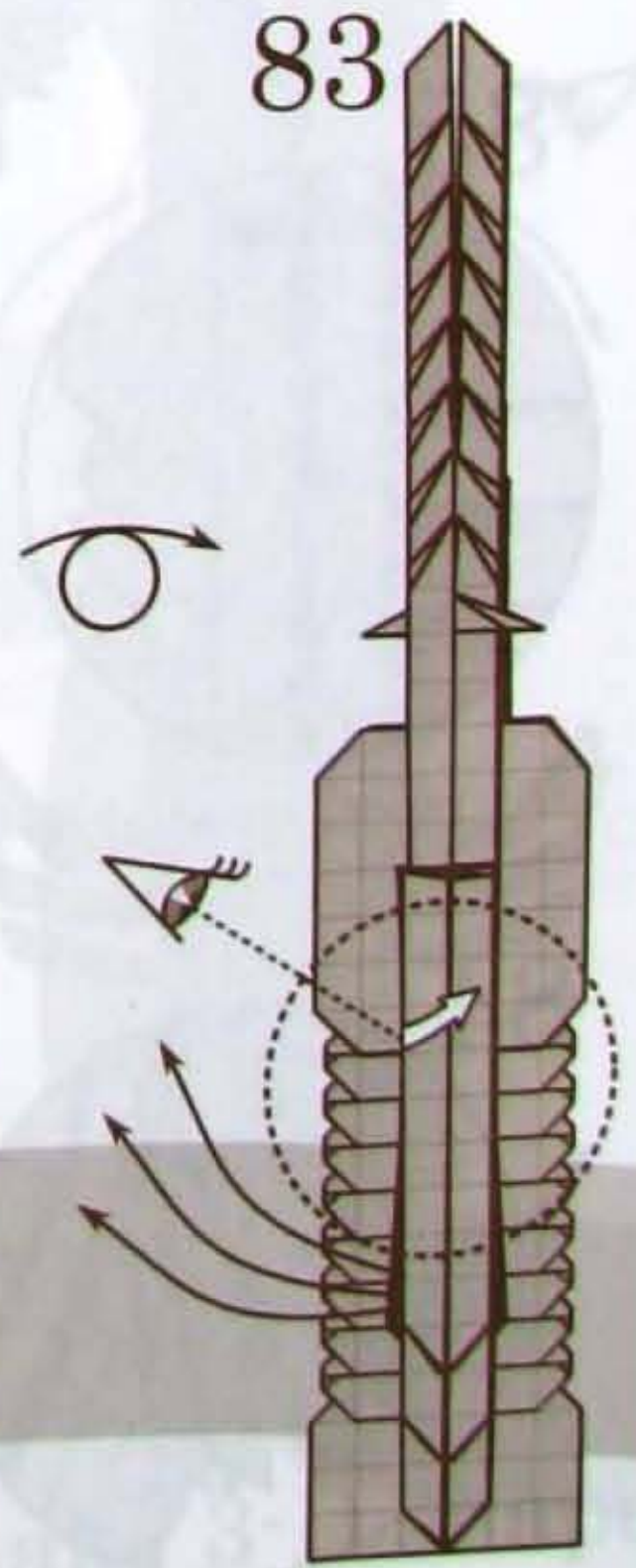
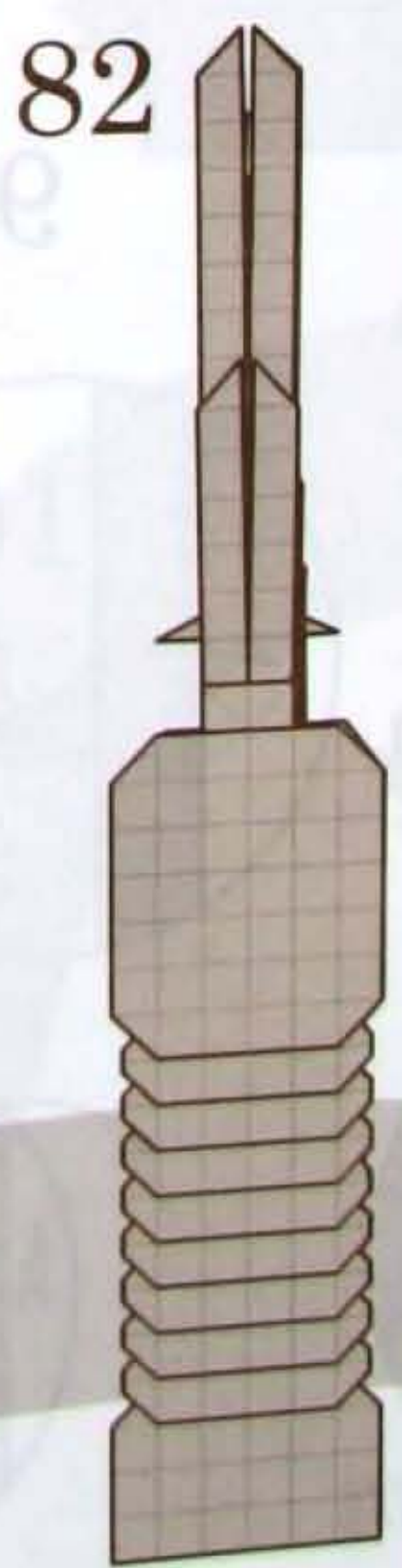

Step 5.2

7 for step 4.3

2

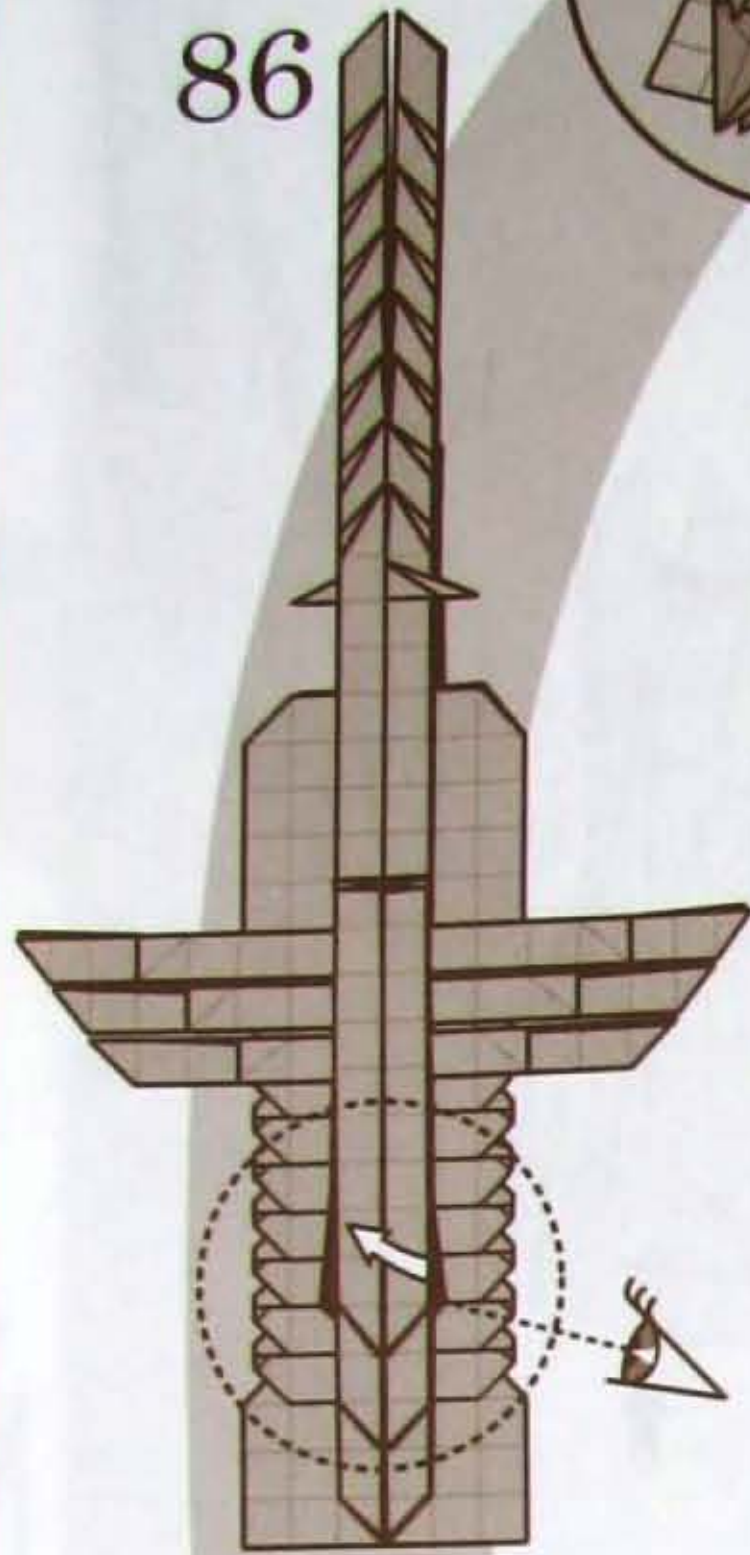

86

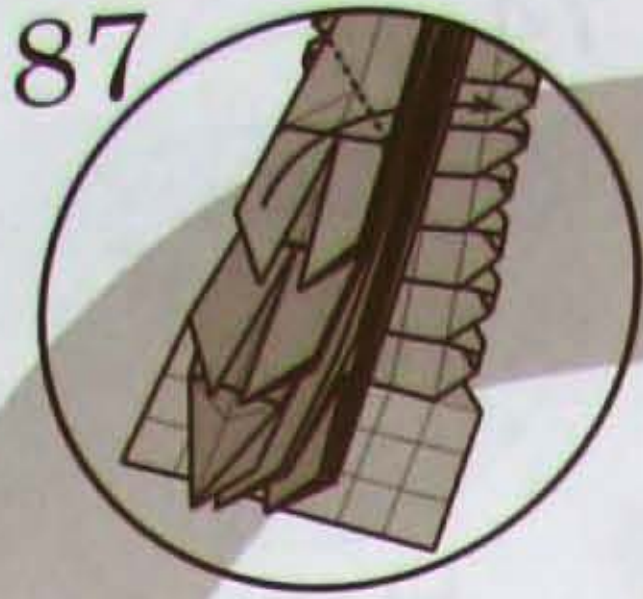

87

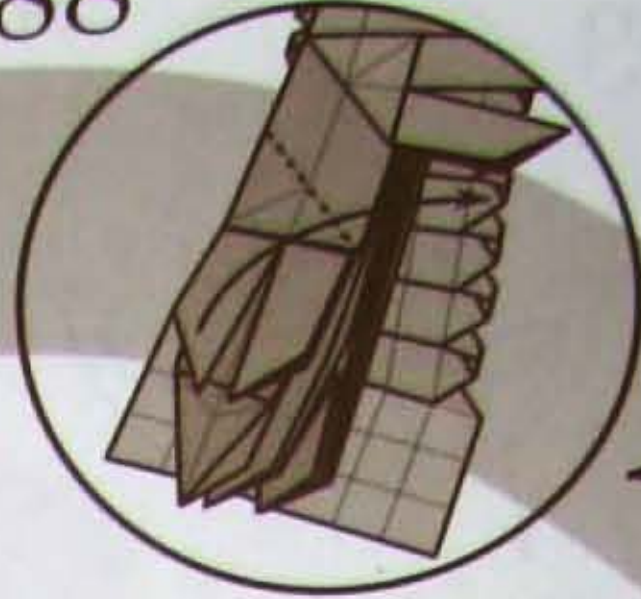

88

repeat for left size

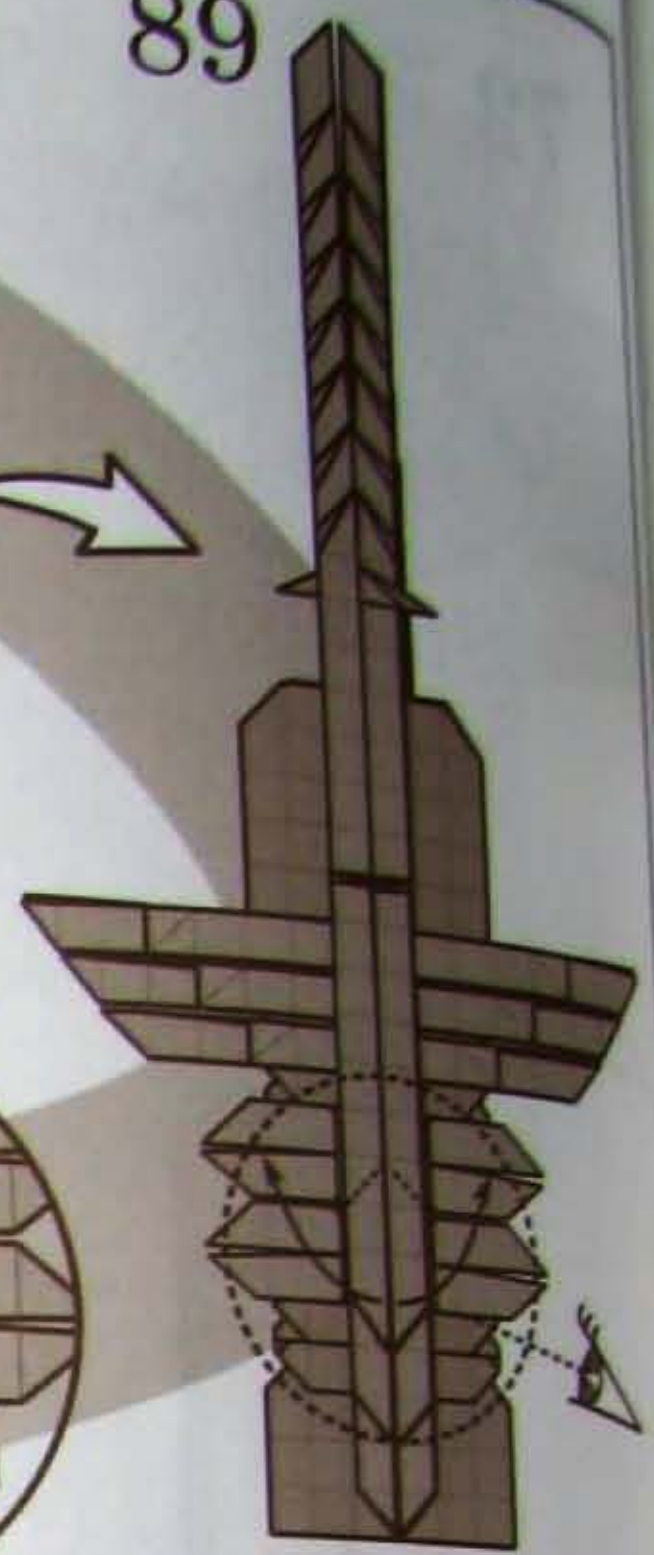

89

90

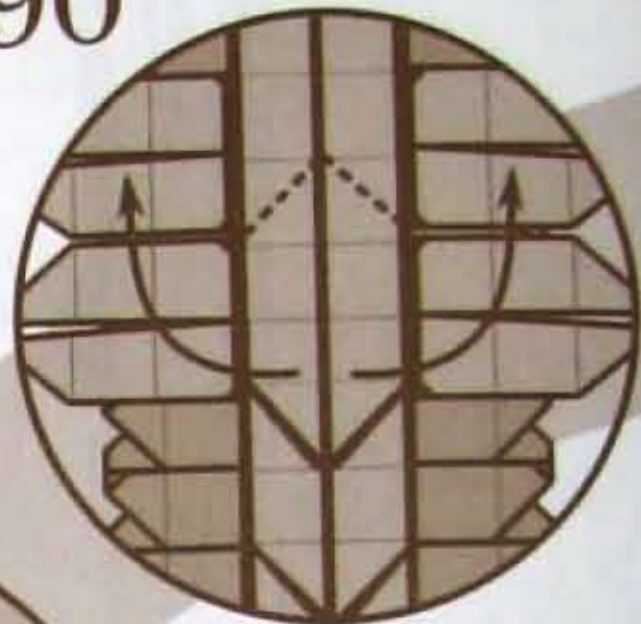

91

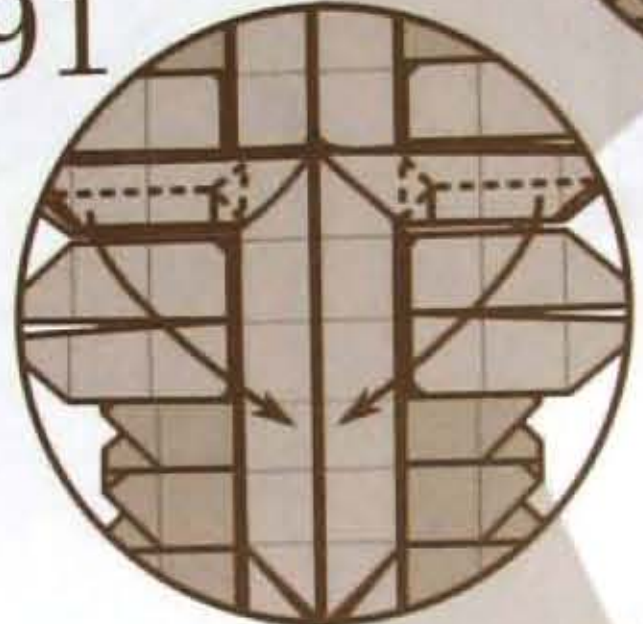

use only one flap

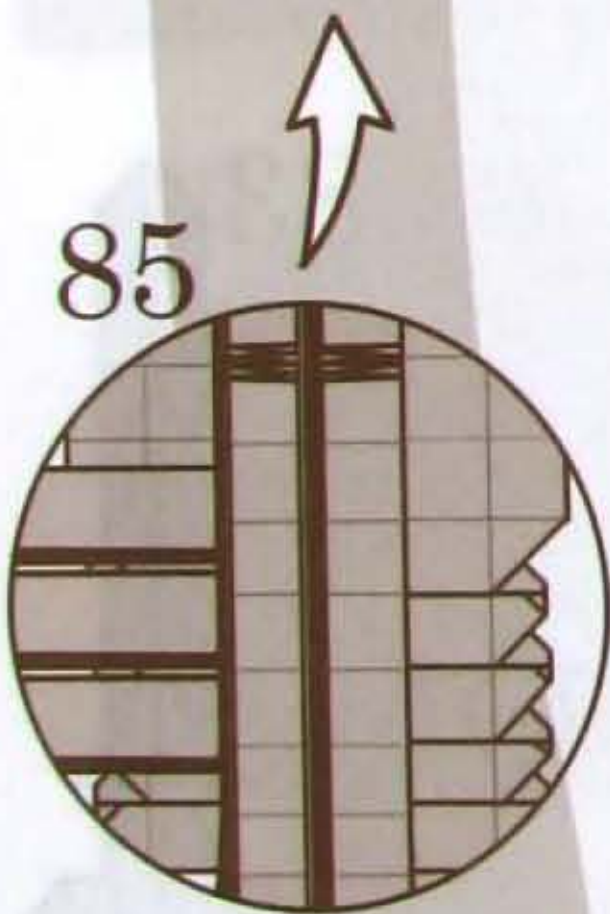

85

repeat steps 84-85

92

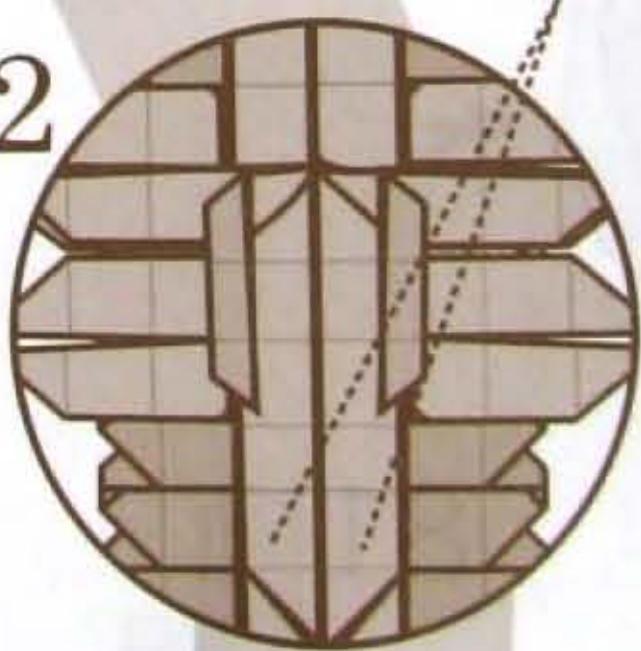

93

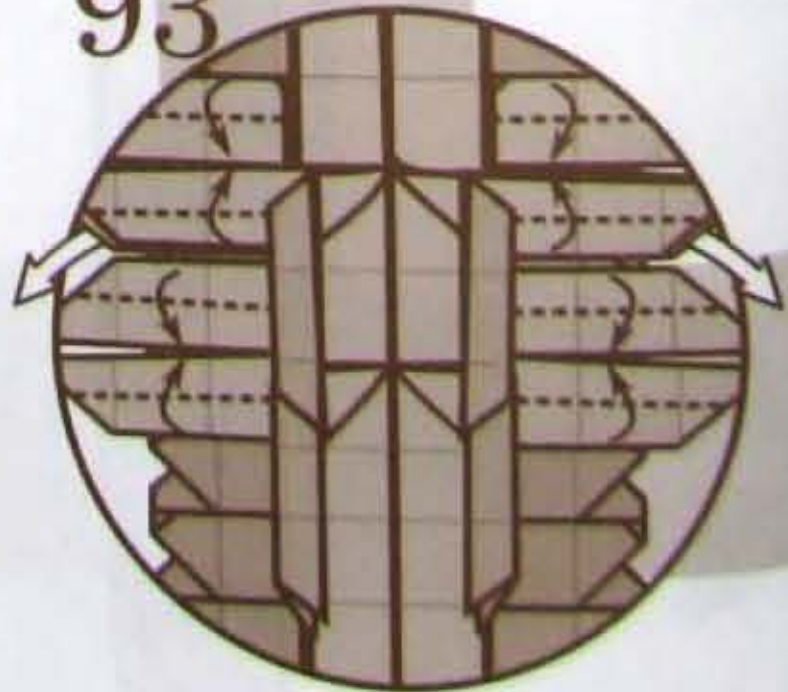

repeat steps 90-92

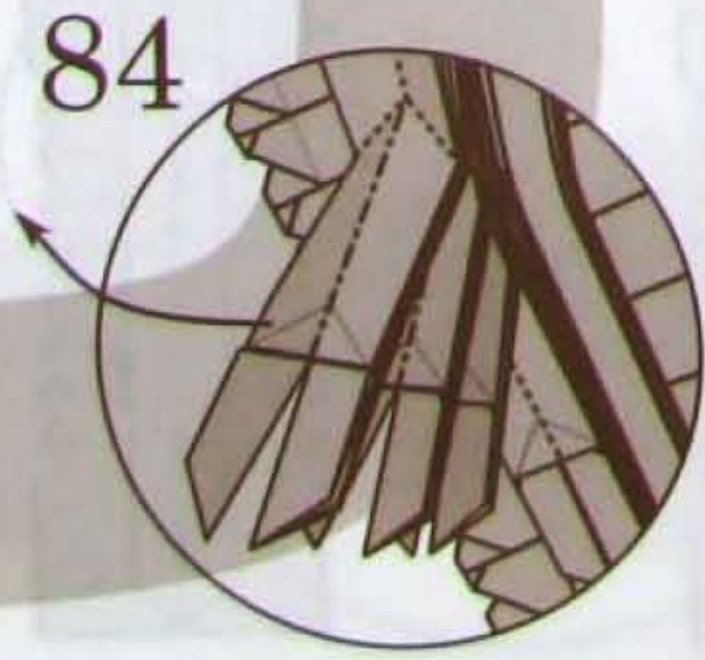

84

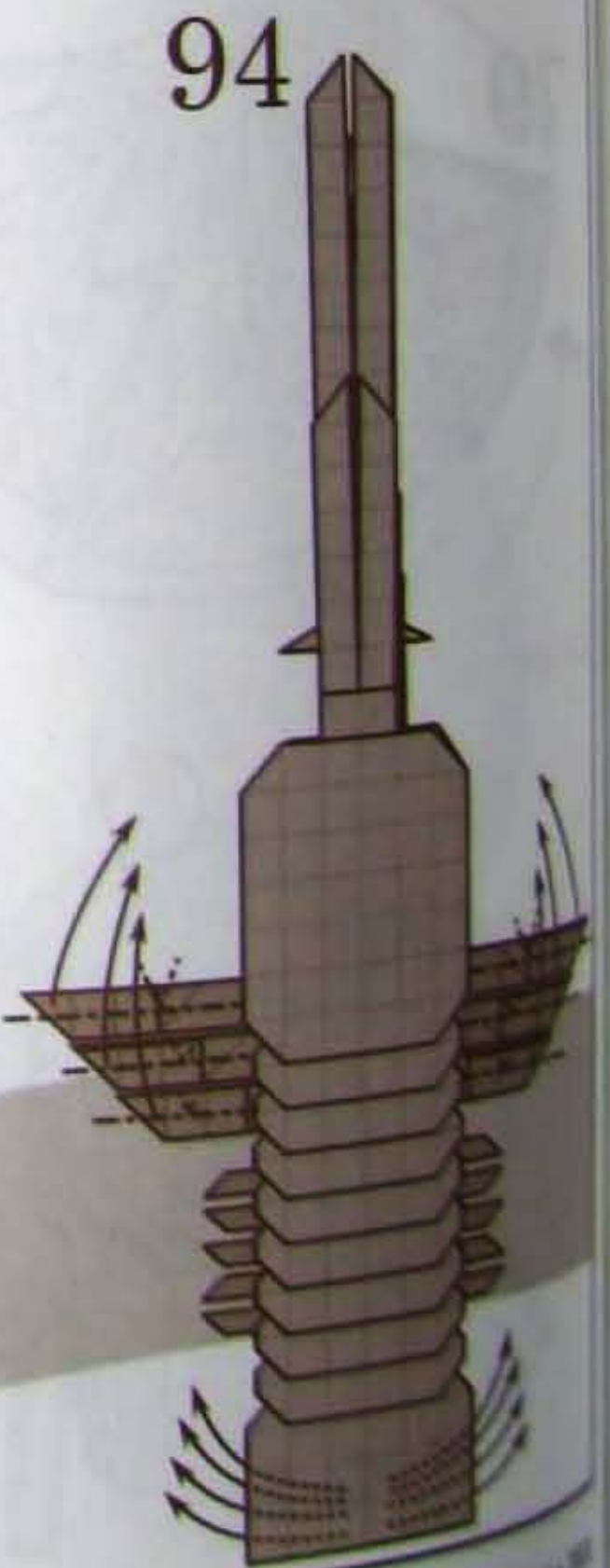

94

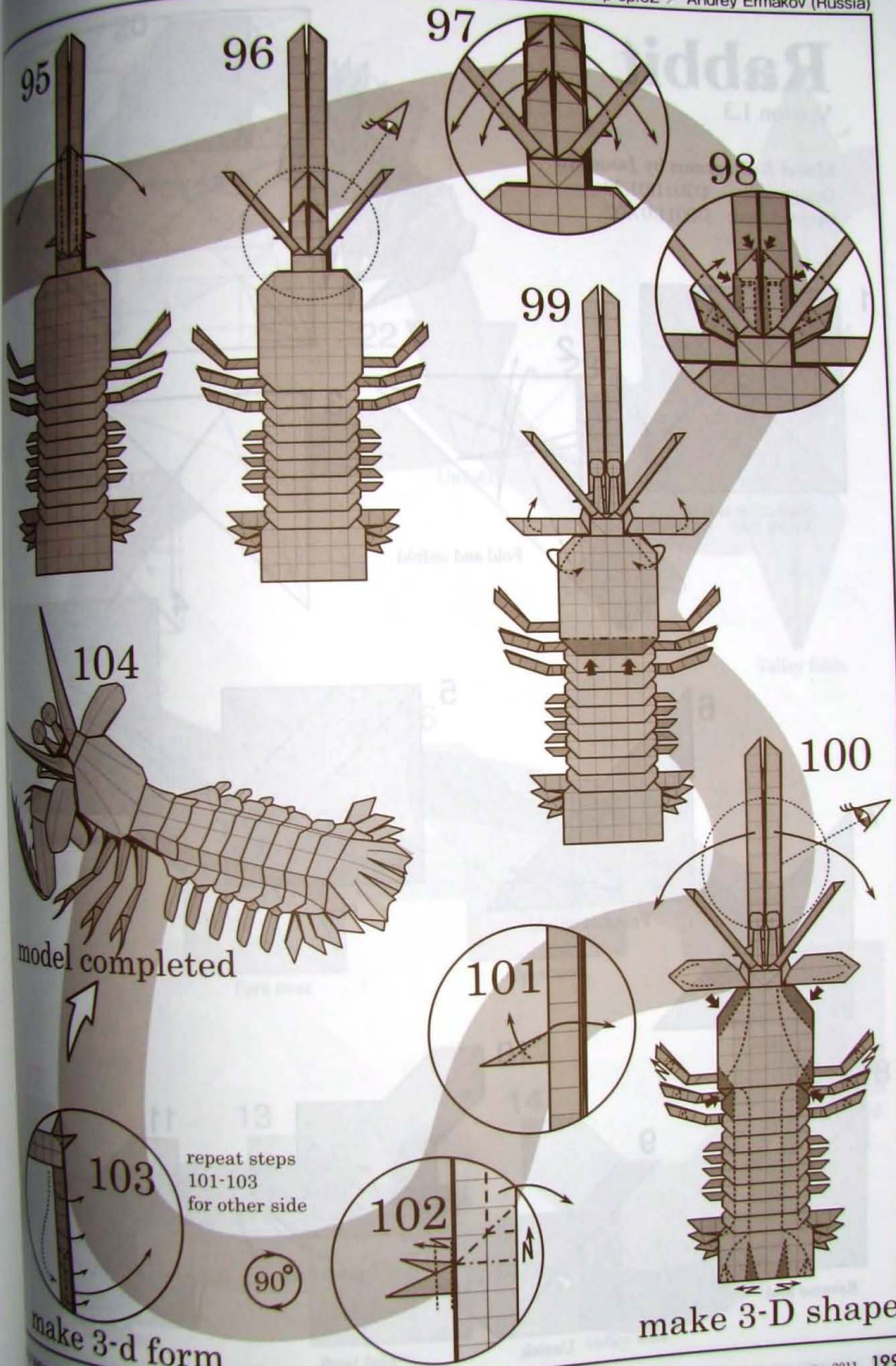

95

96

97

98

99

104

100

101

102

103

repeat steps 101-103 for other side

90°

make 3-d form

make 3-D shape

Rabbit

Version 1.3

Model & Diagrams by Jason Ku

Designed: ©2011/01/23

Diagrammed: ©2011/07/02

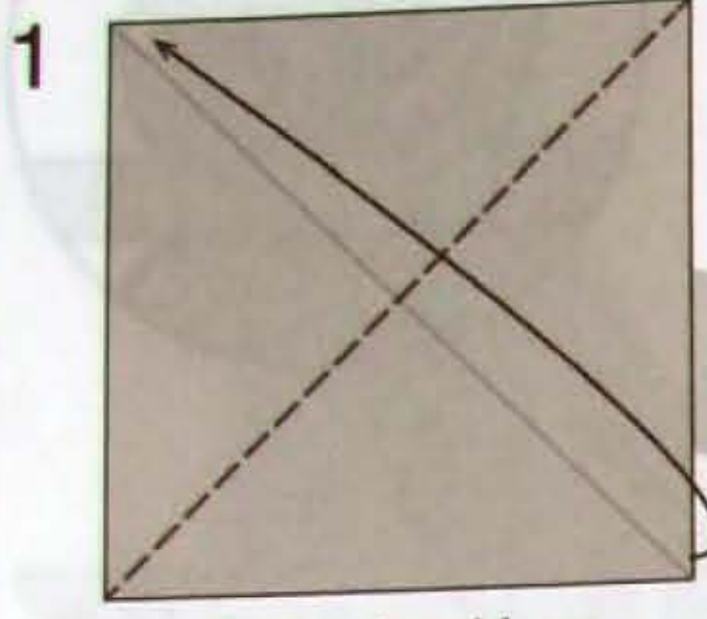
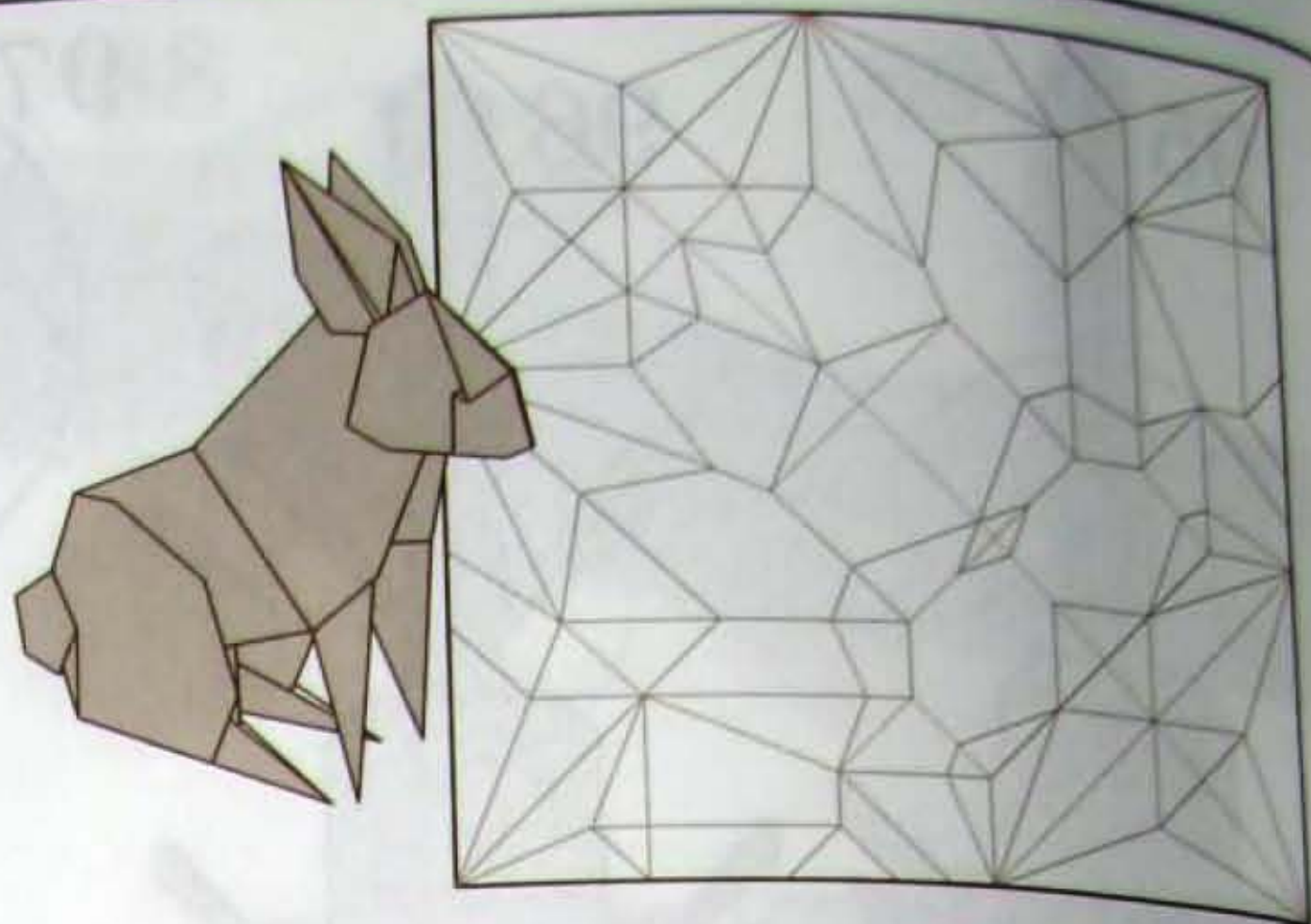

Start color side up. Valley fold.

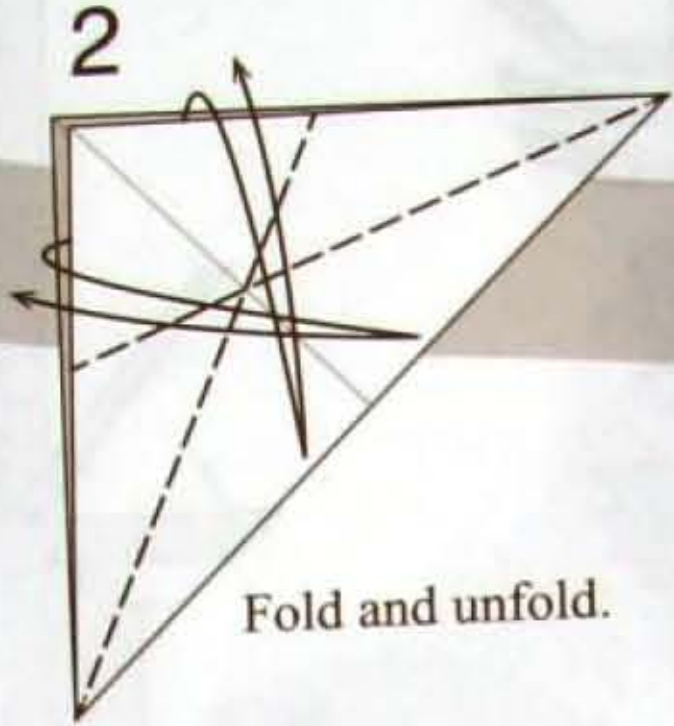

Fold and unfold.

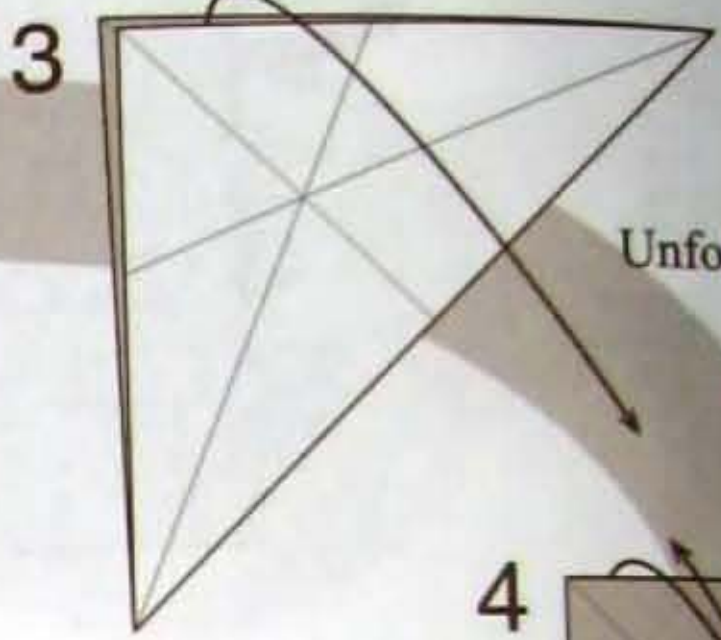

Unfold.

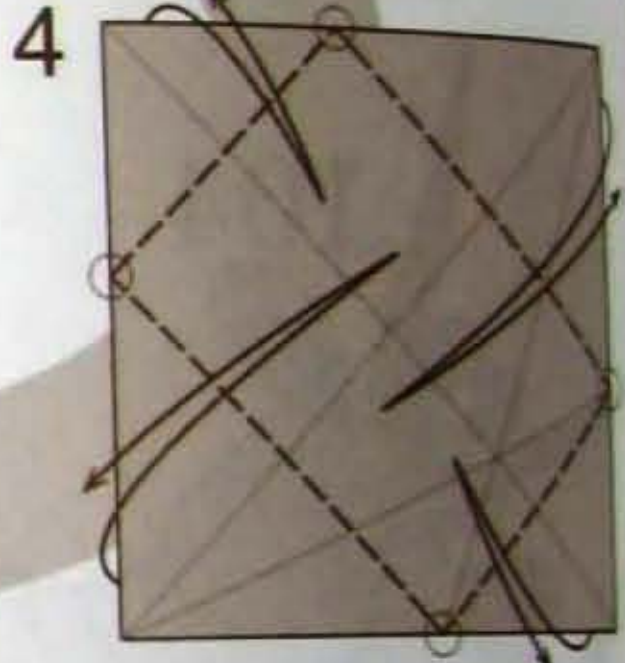

Fold and unfold.

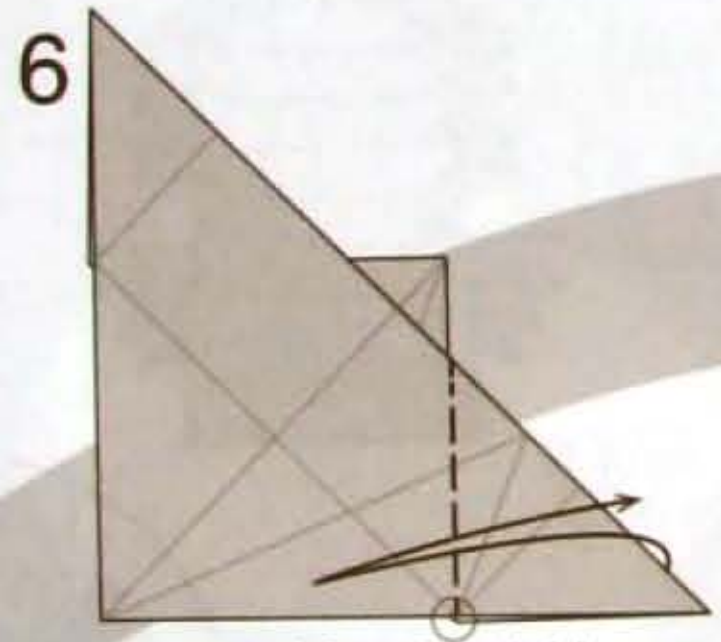

Fold and unfold.

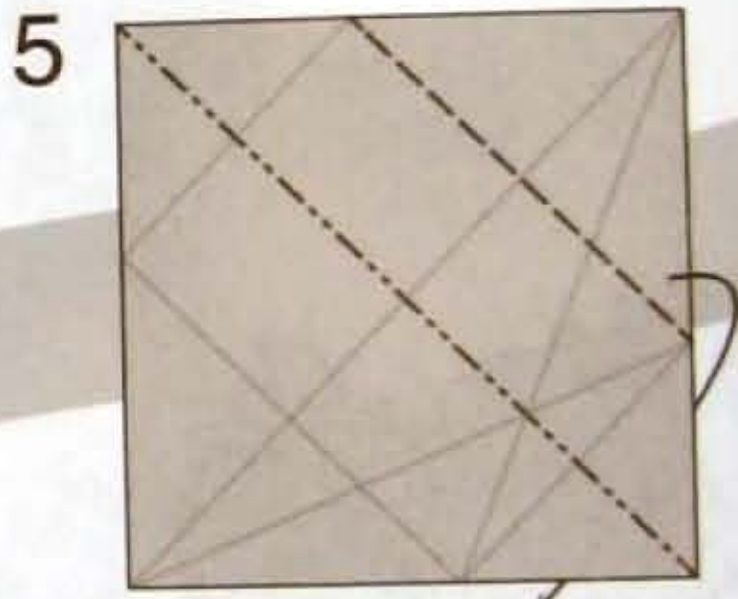

Pleat.

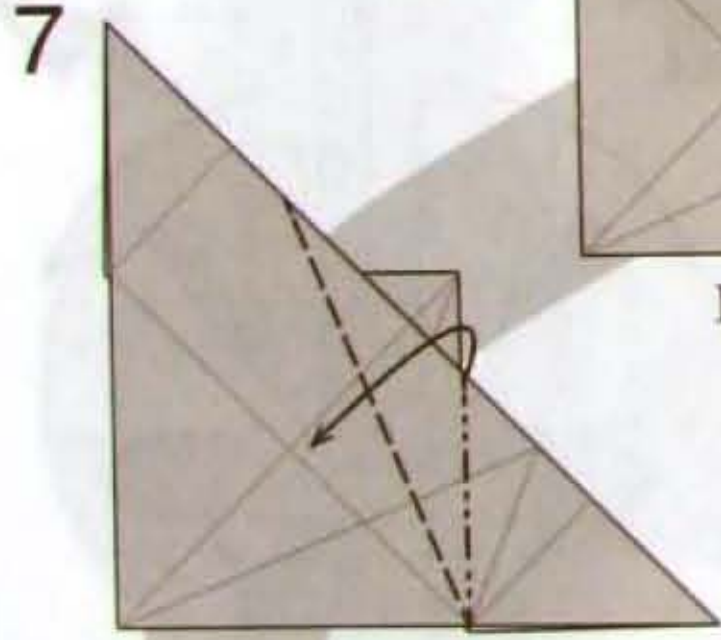

Pleat.

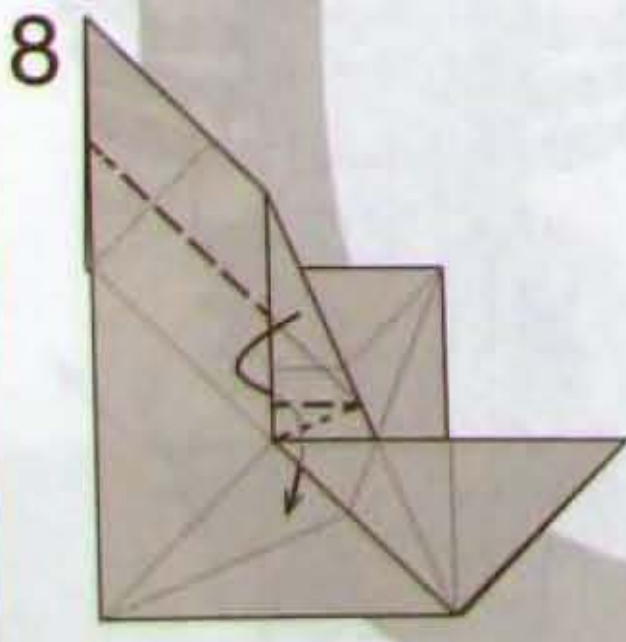

Reverse fold.

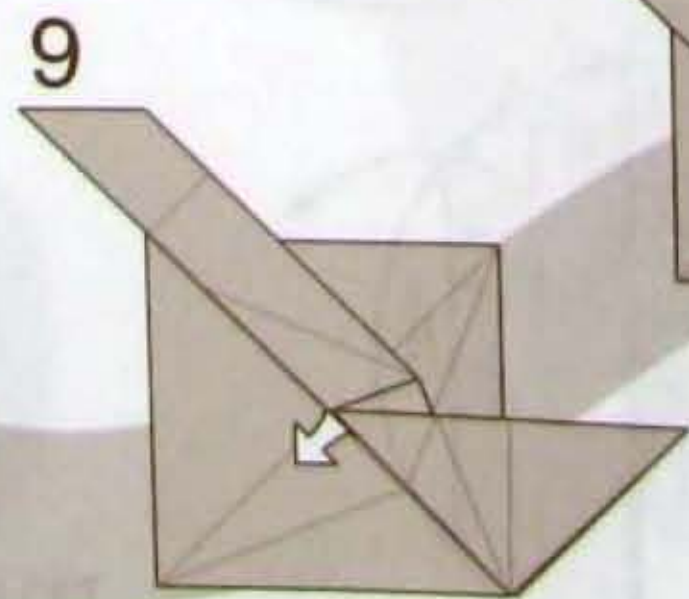

Unsink.

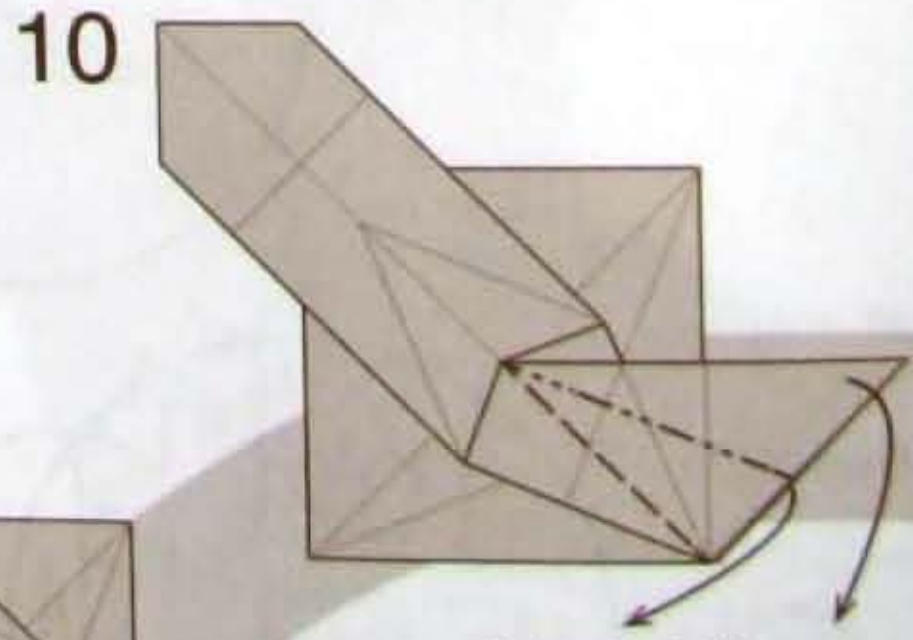

Squash fold.

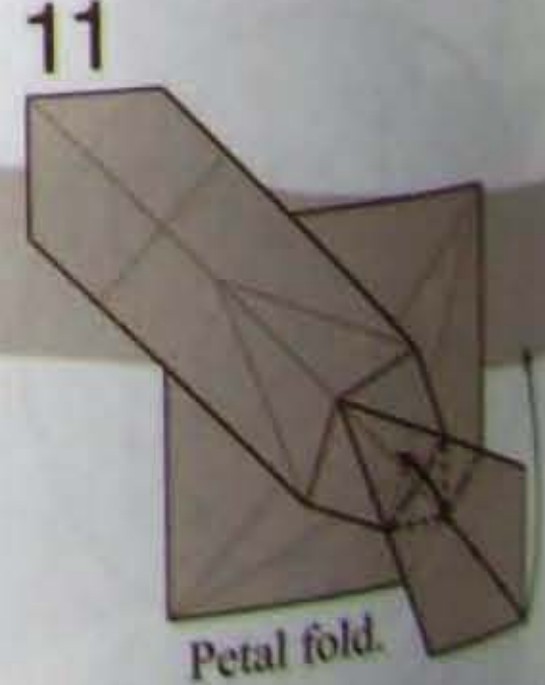

Petal fold.

19



In progress

18



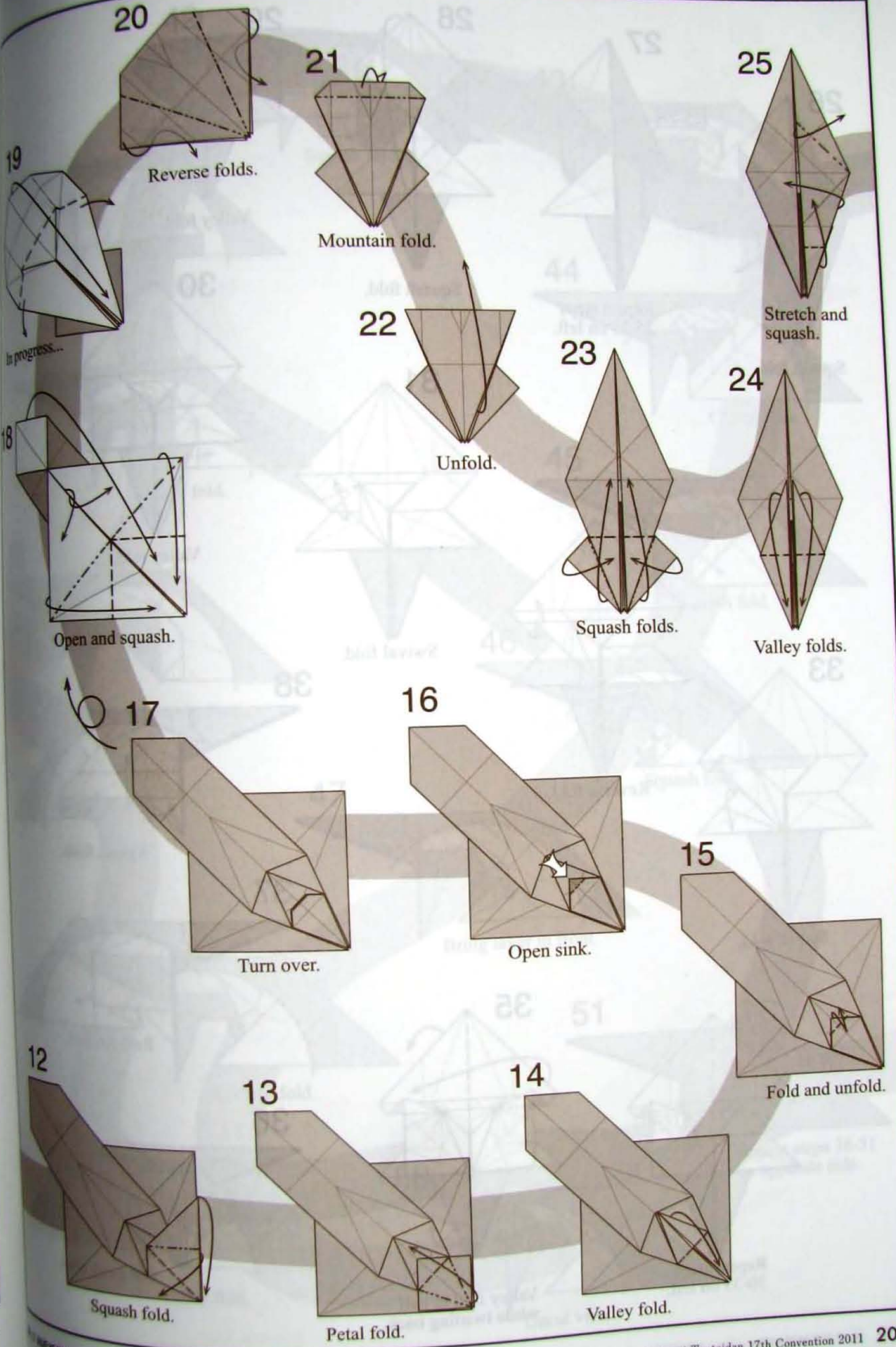

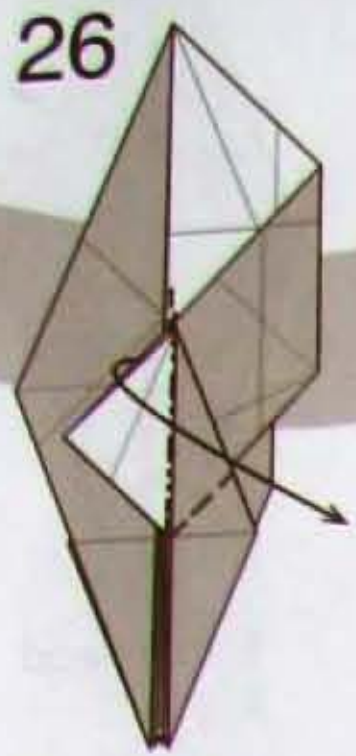

Squash fold.

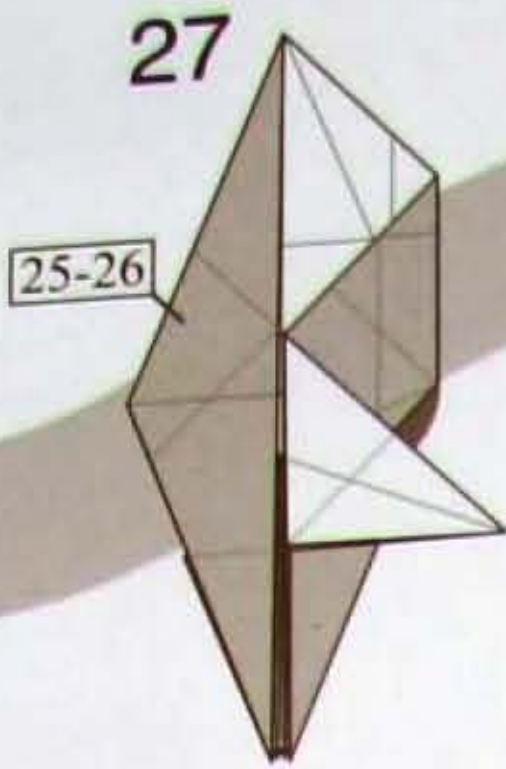

Repeat steps 25-26 on left.

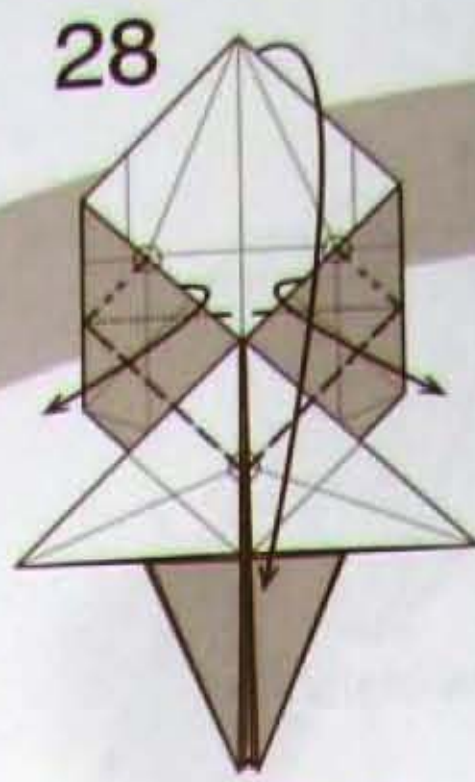

Squash fold.



Valley fold.

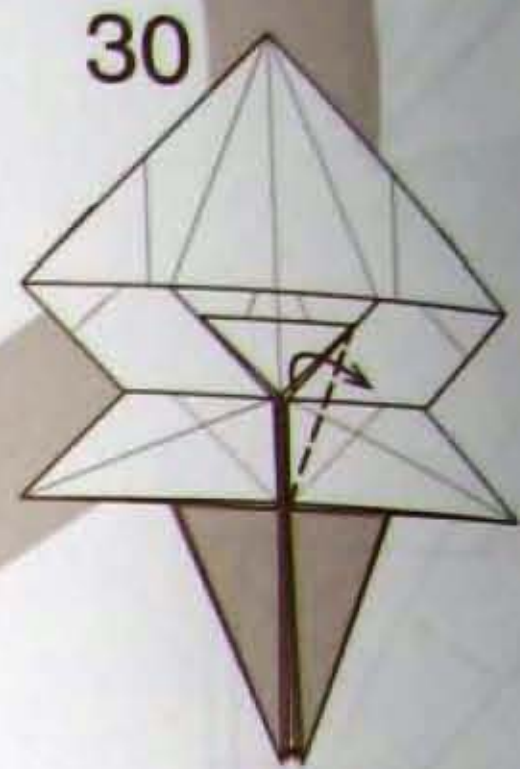

Valley fold.

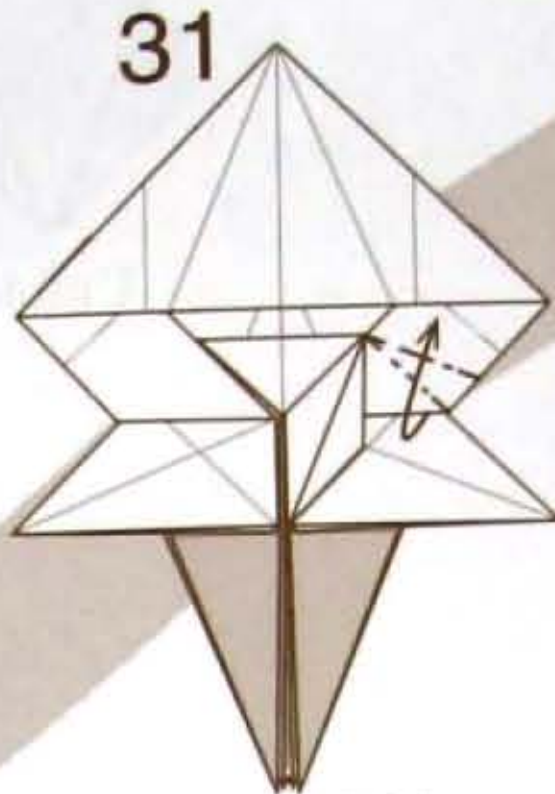

Swival fold.



Reverse fold.



Swival fold.

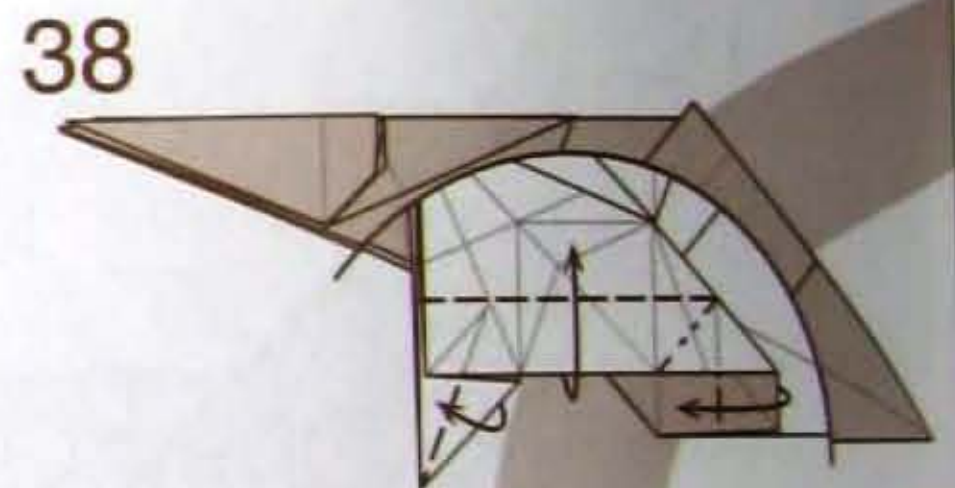

Squash folds.

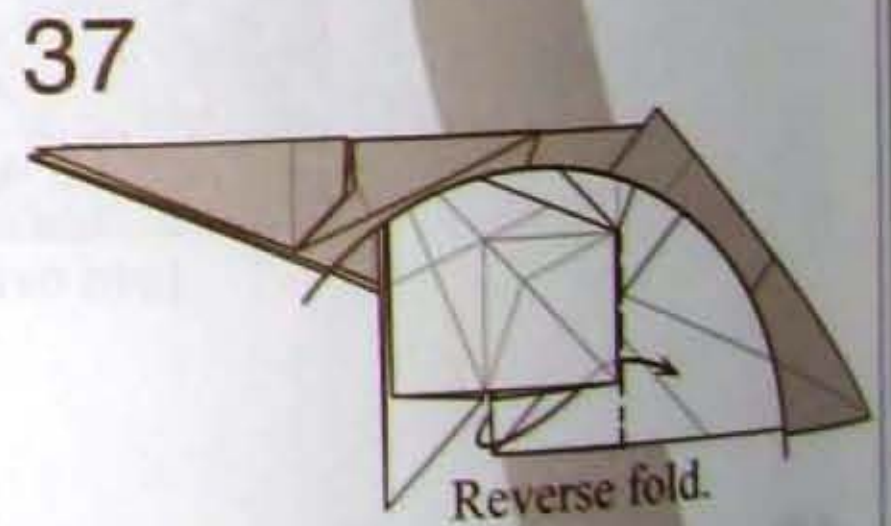

Reverse fold.

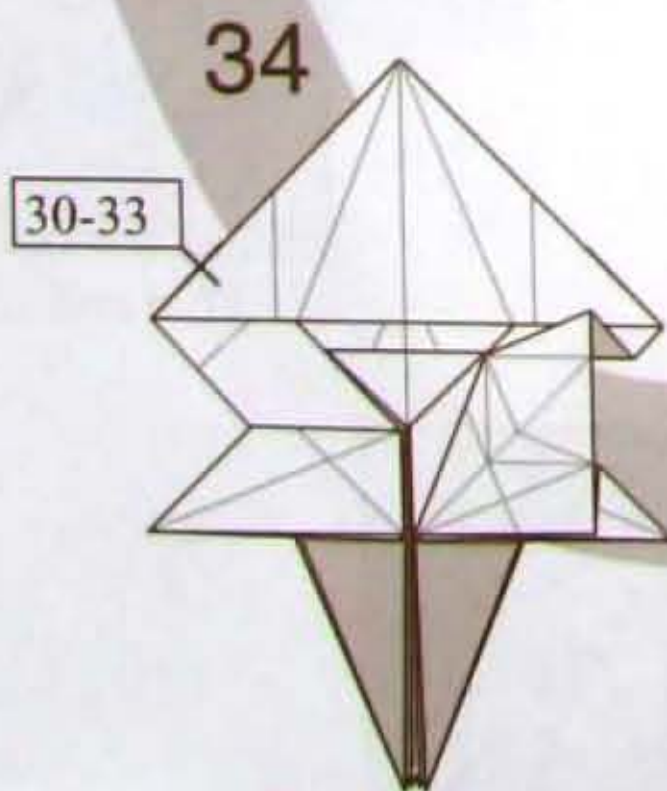

Repeat steps 30-33 on left.

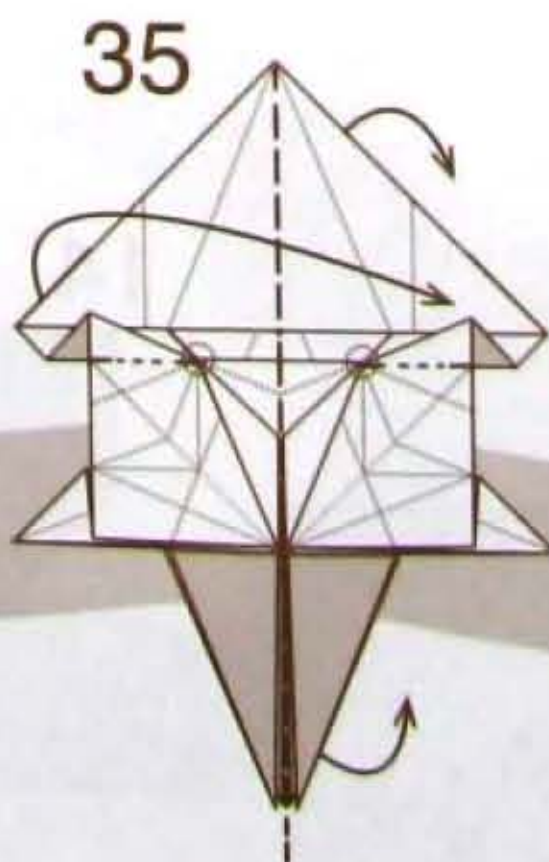

Valley fold in half while twisting back.

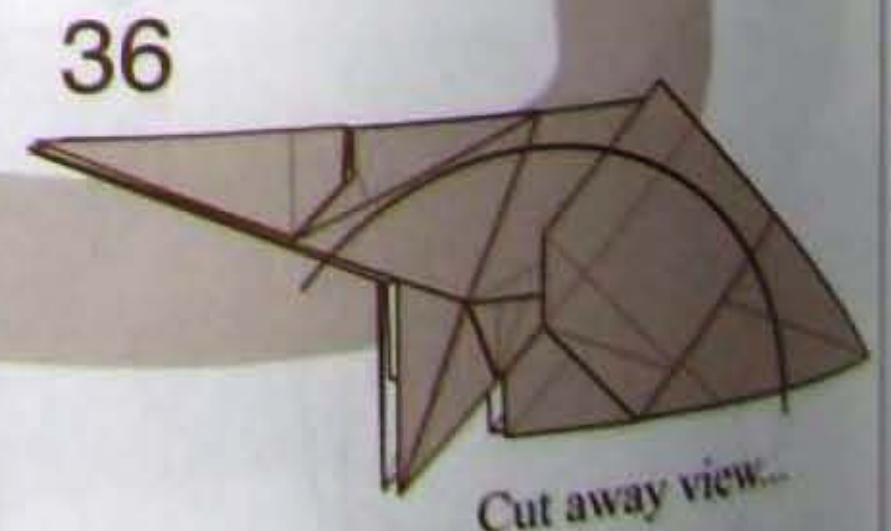

Cut away view...



42

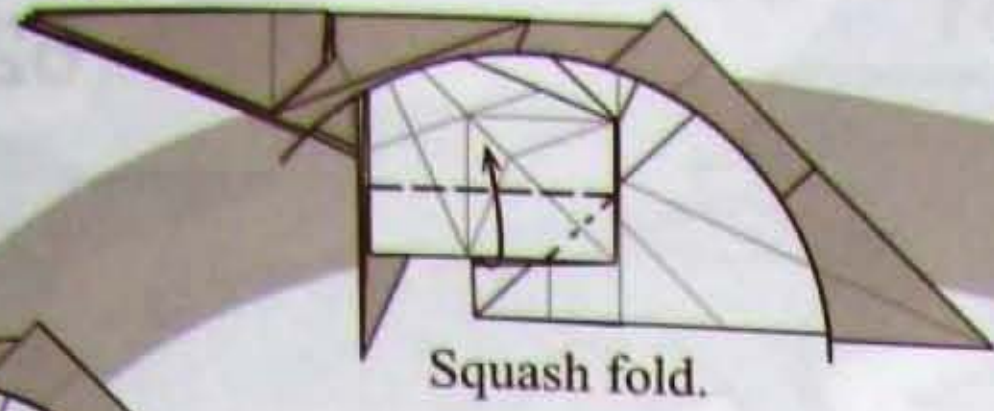

Squash fold.

43

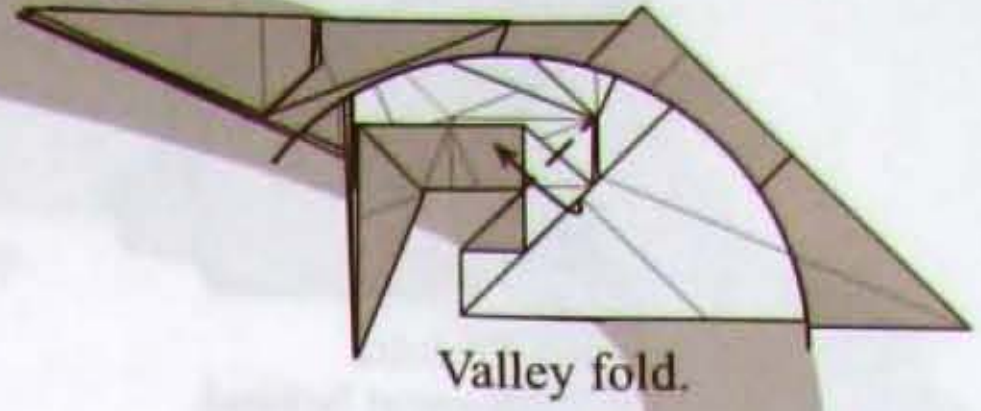

Valley fold.

41

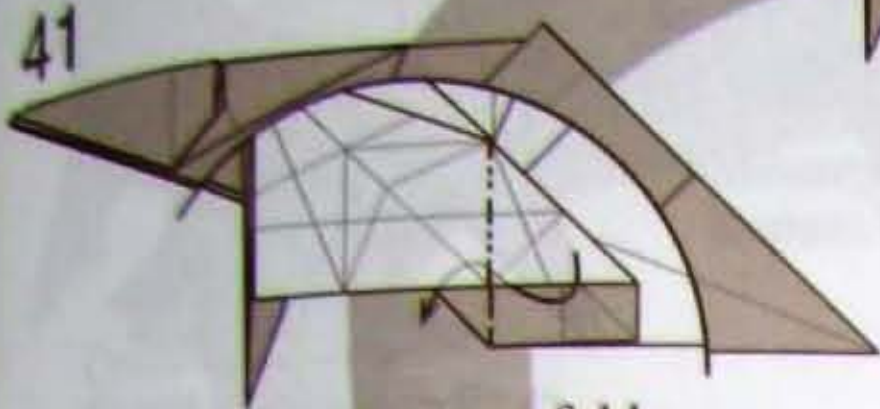

Reverse fold.

44

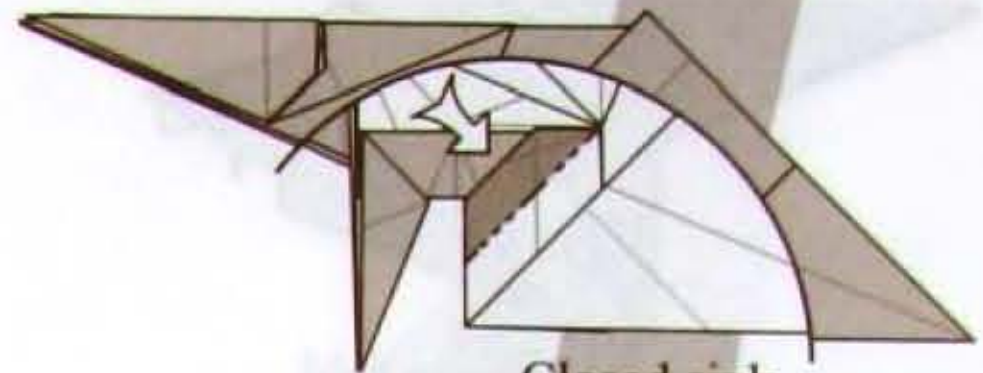

Closed sink.

40

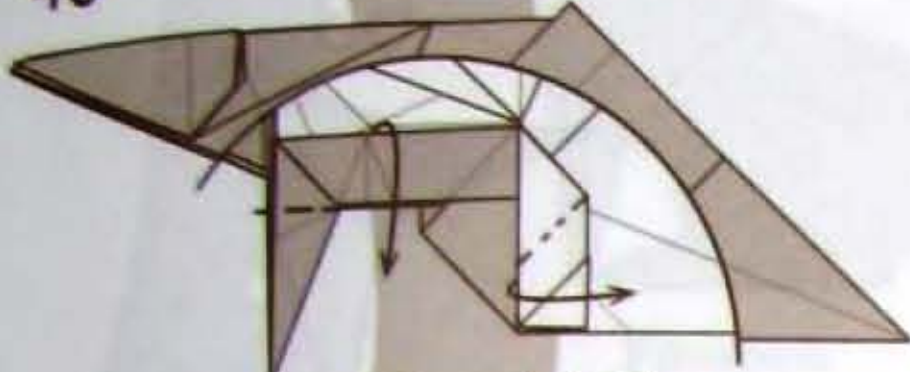

Squash fold.

45

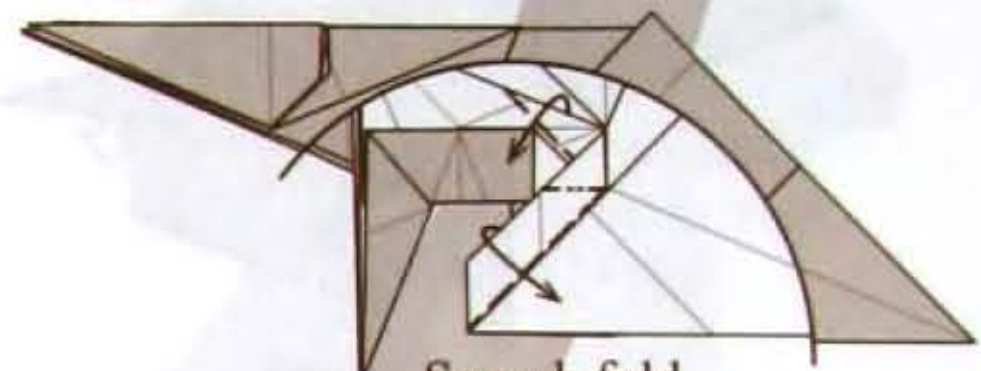

Squash fold.

39

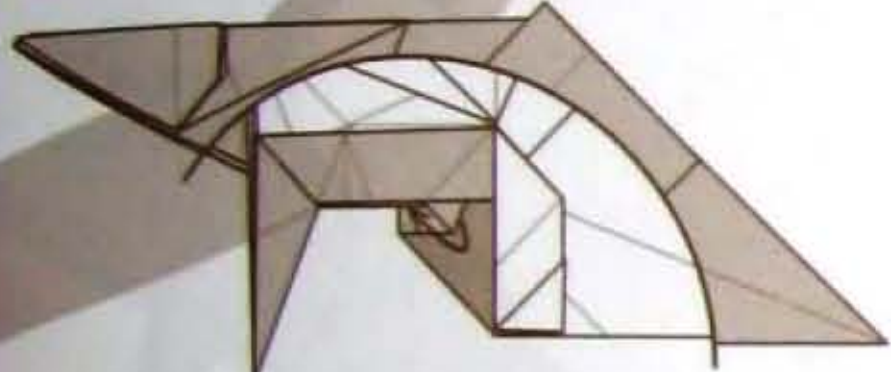

Bring layer in front.

46

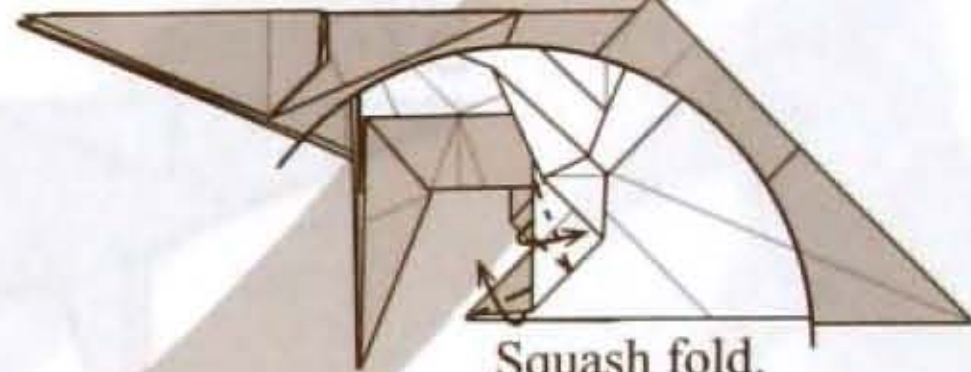

Squash fold.

47

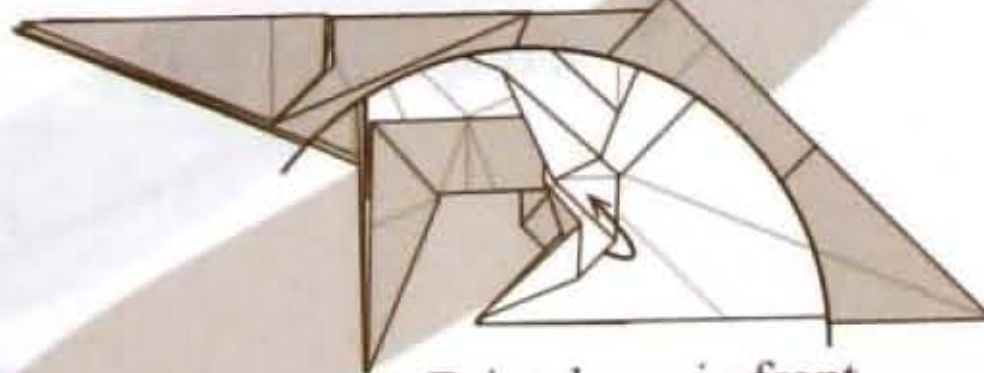

Bring layer in front.

48

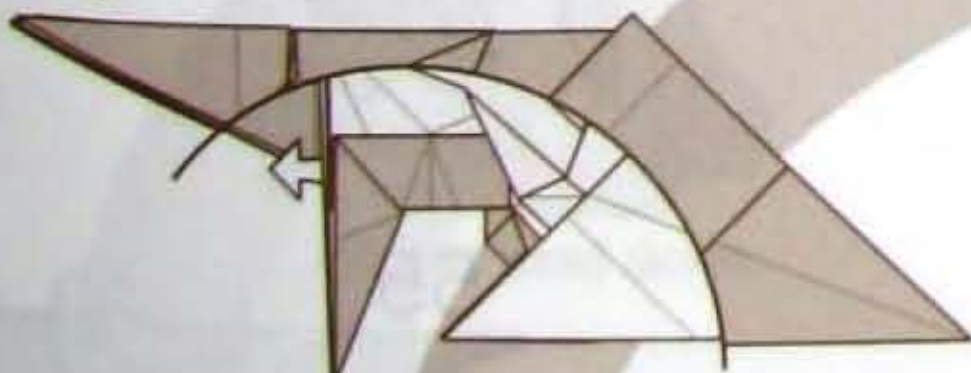

Reverse fold.

51

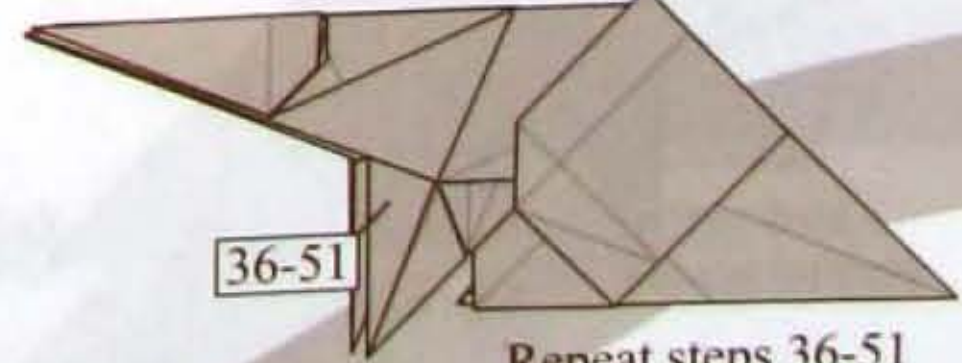

Repeat steps 36-51 on opposite side.

49



Valley fold.

50

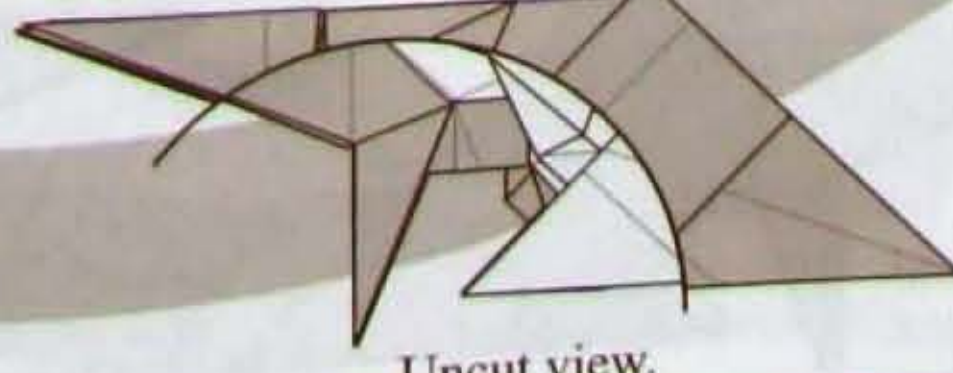

Uncut view.

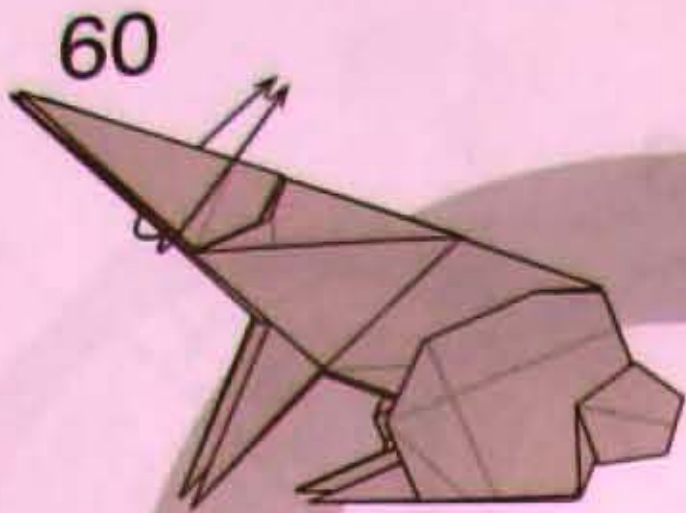

60
Unfold.
Repeat behind.

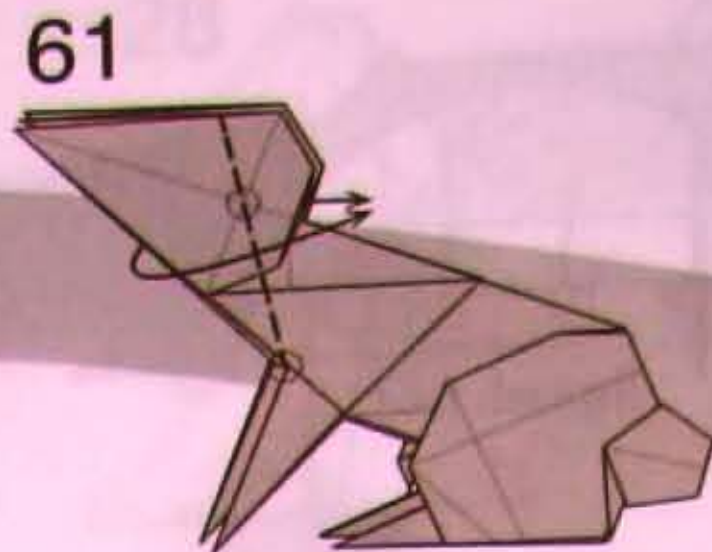

61
Valley fold.
Repeat behind.

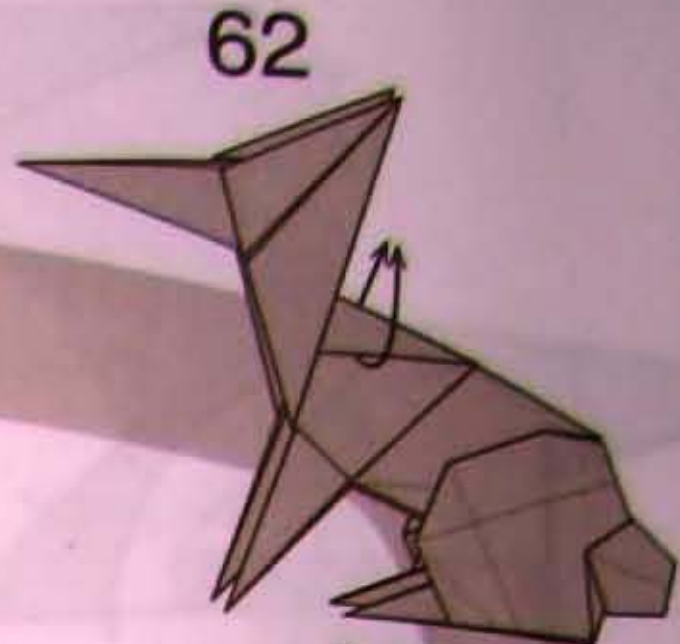

62
Reverse fold.
Repeat behind.

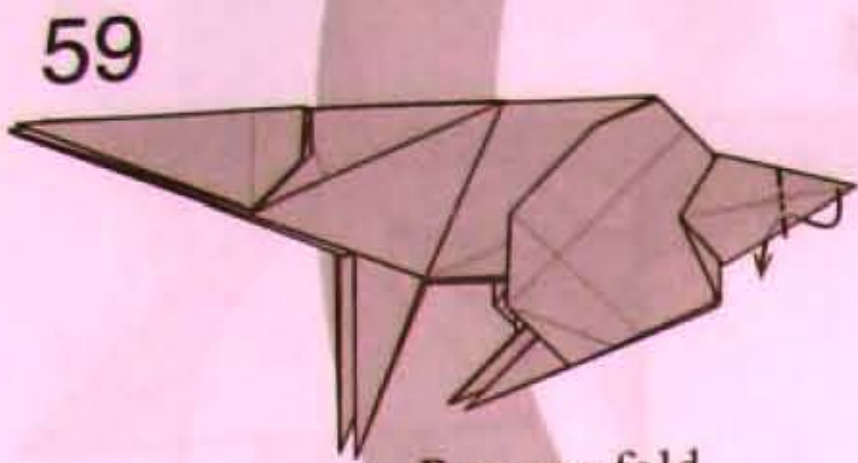

59
Reverse fold.



58
Pull out.
Repeat behind.

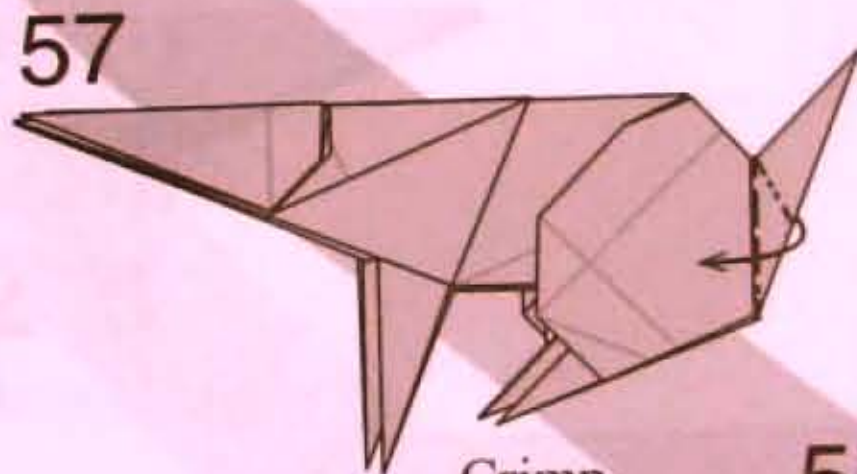

57
Crimp.

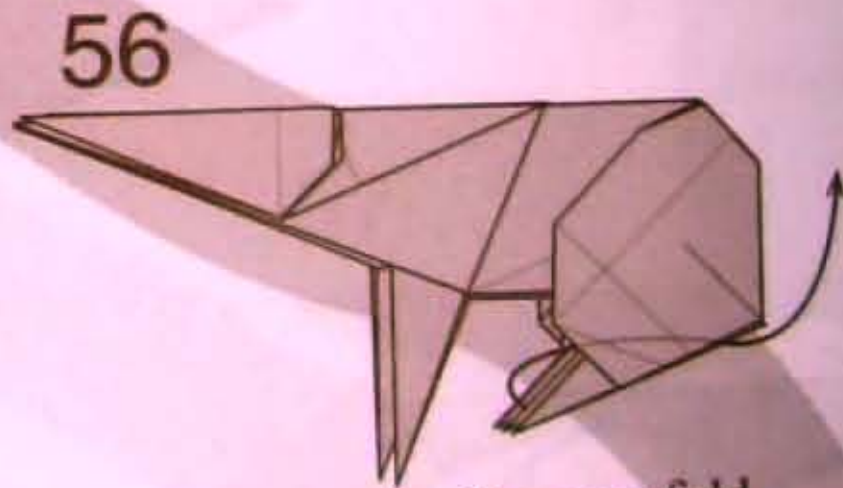

56
Reverse fold.

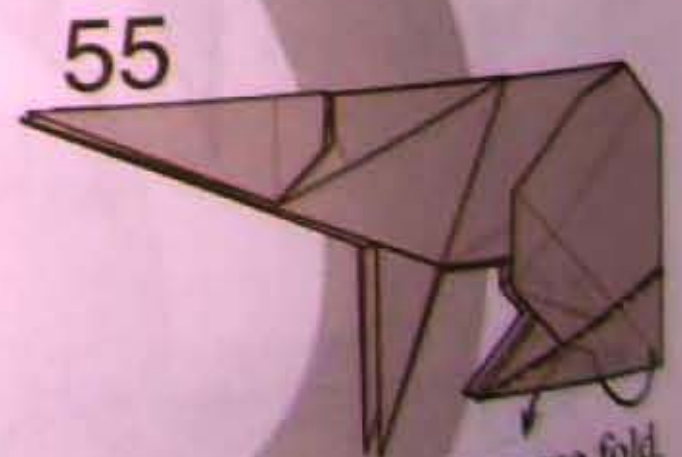

55
Reverse fold.
Repeat behind.

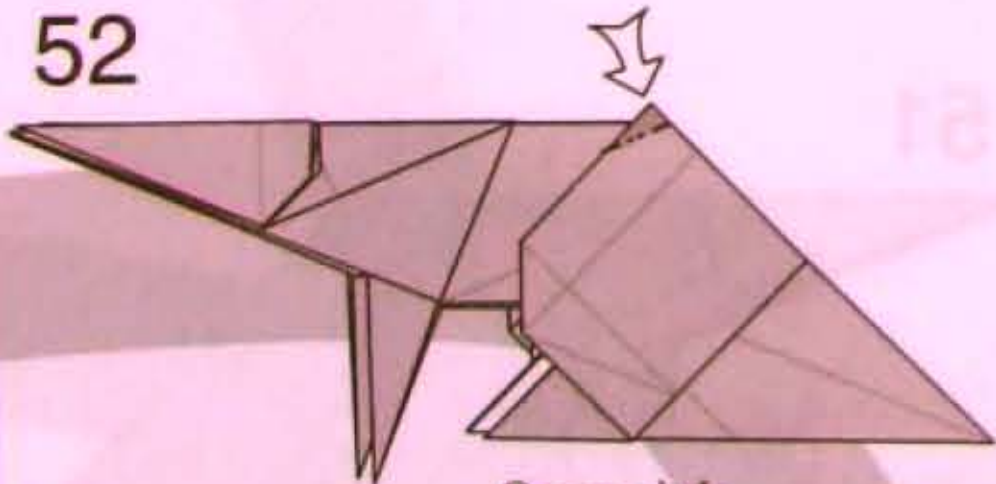

52
Open sink.

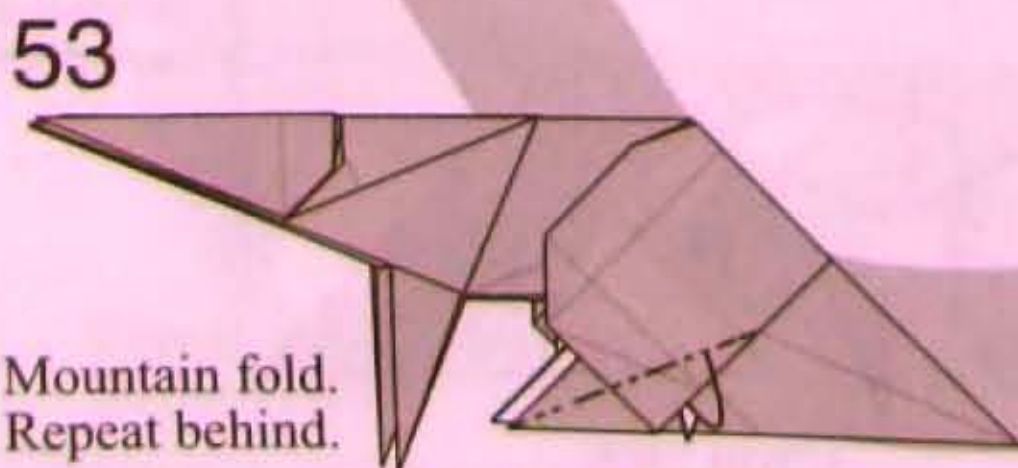

53
Mountain fold.
Repeat behind.

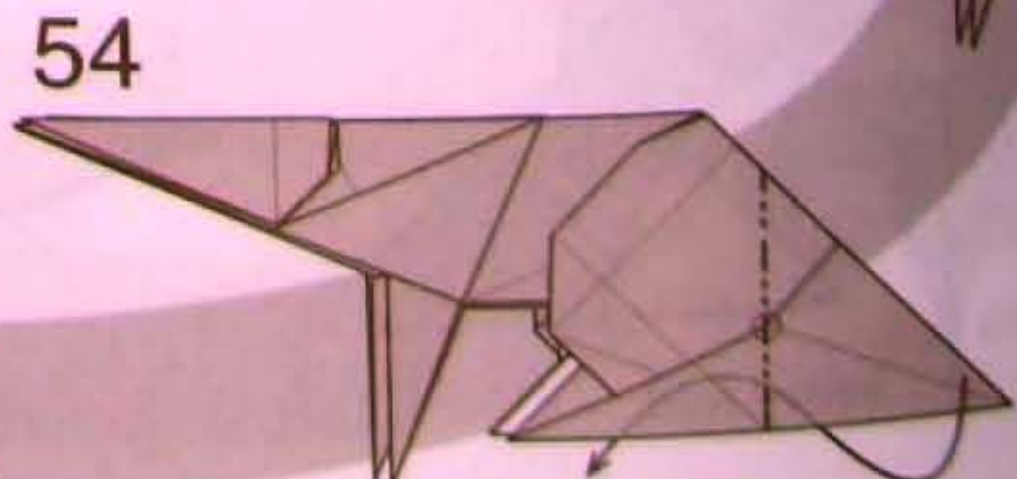

54
Reverse fold.

Japão Burajirujin

www.japaoburajirujin.blogspot.com

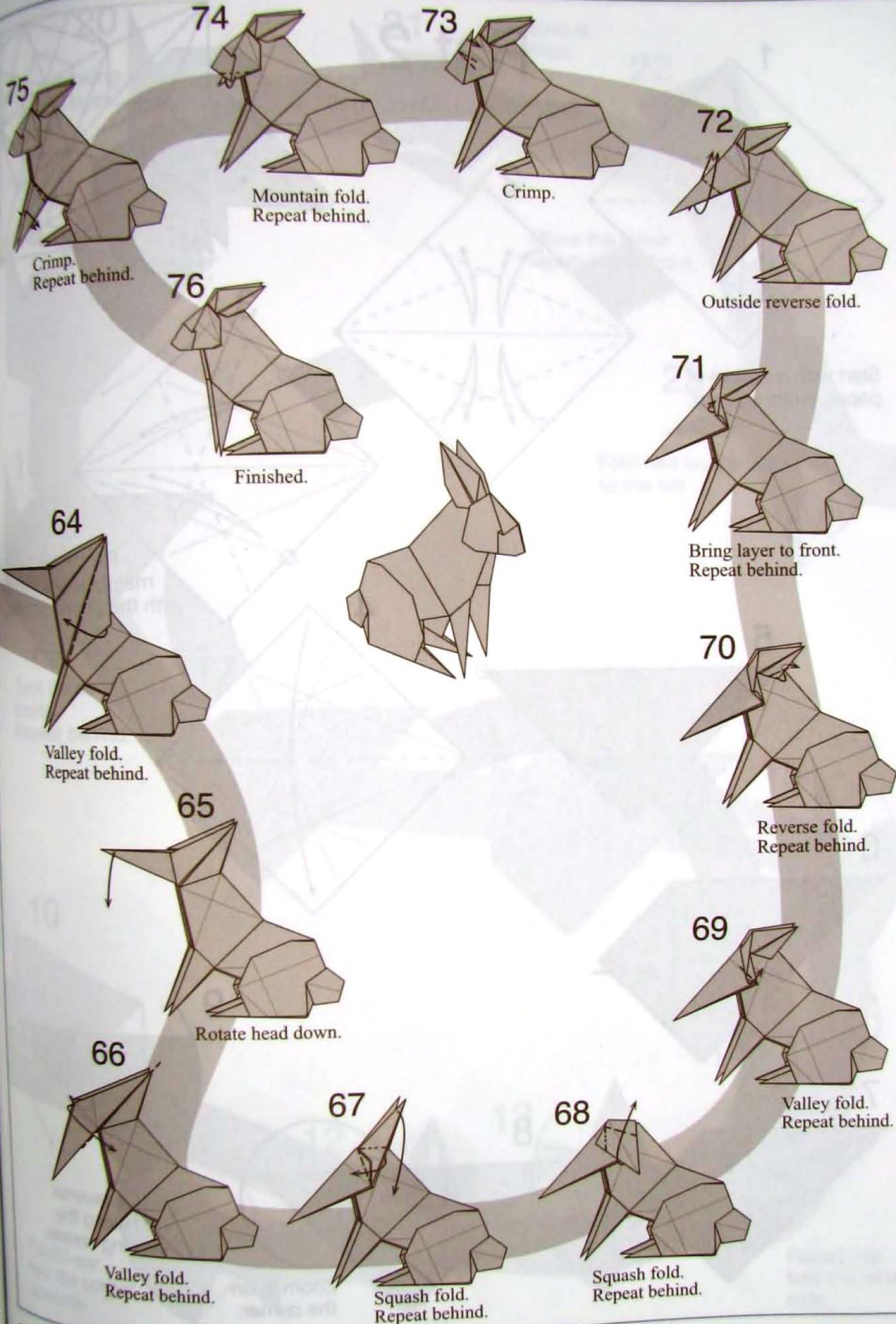

Rat 2

© 2010 Ryan MacDonell

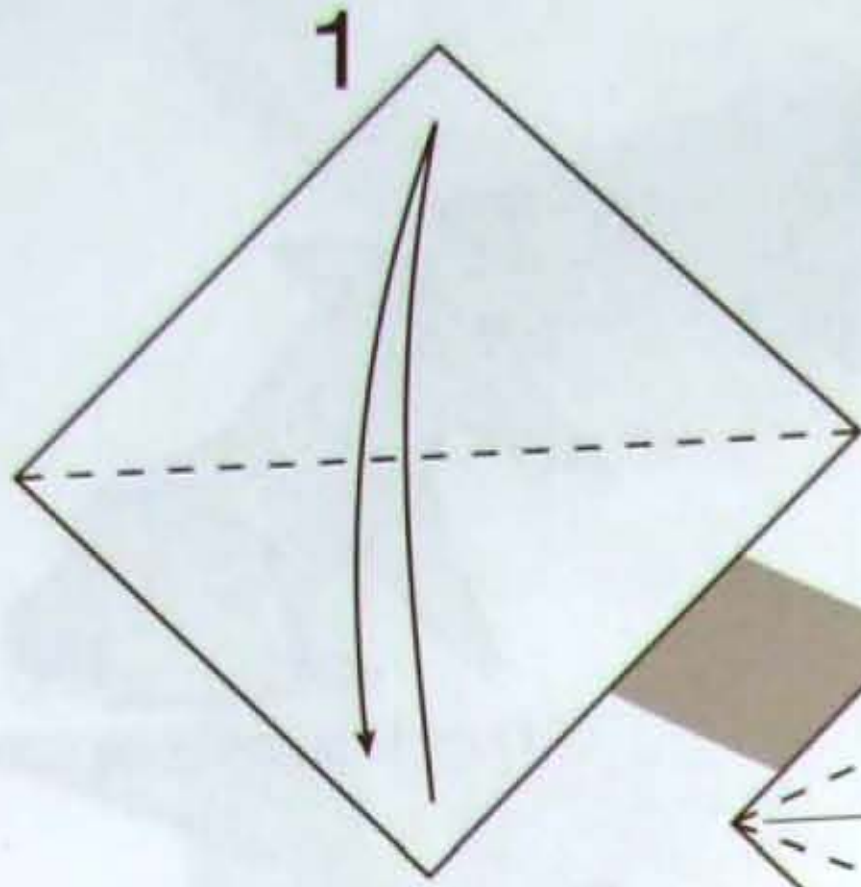

Start with a square of paper, white side up.

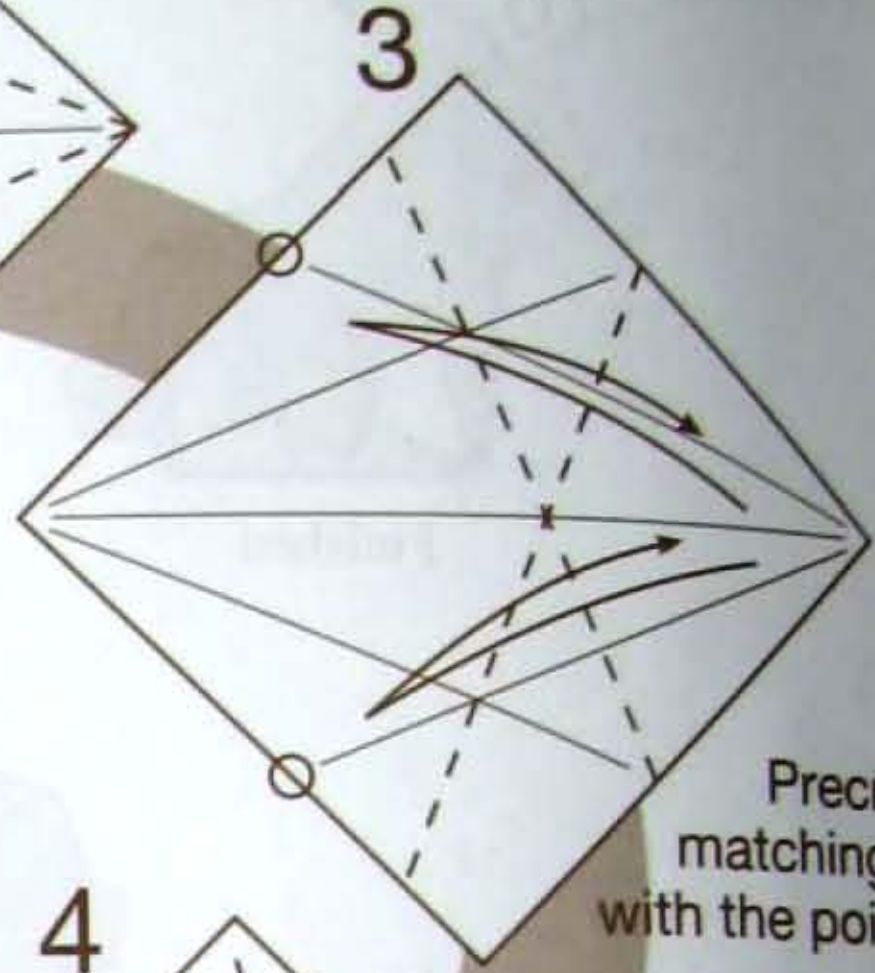
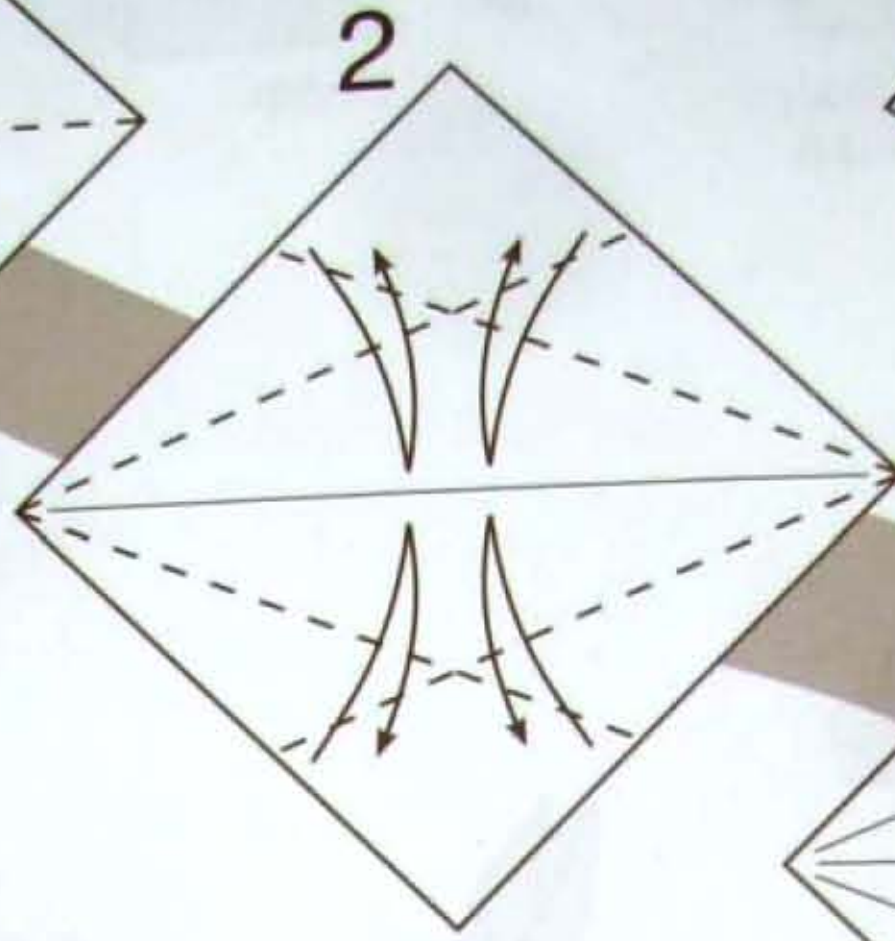

Precrease by matching the corner with the points shown.

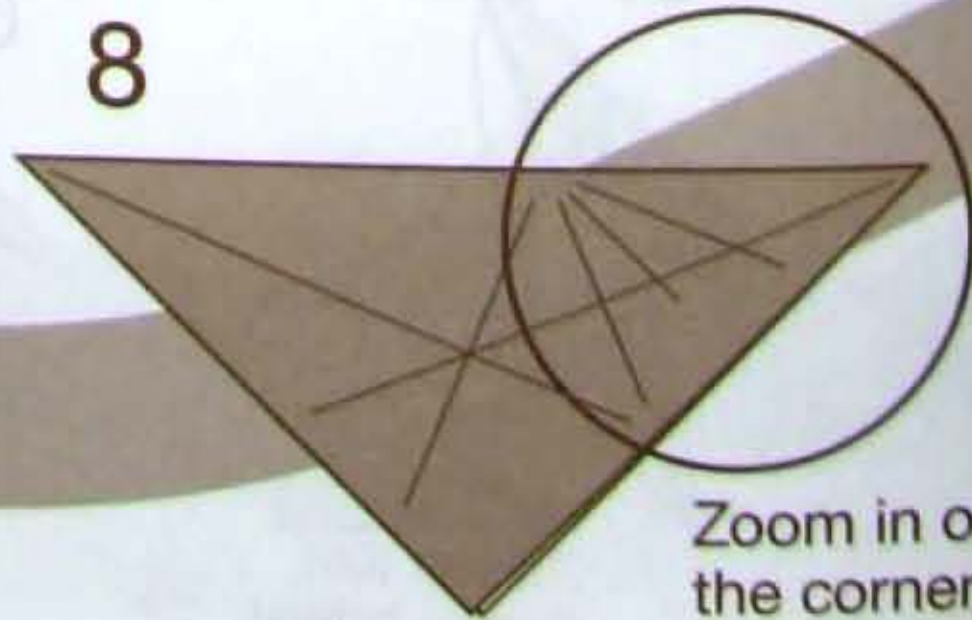
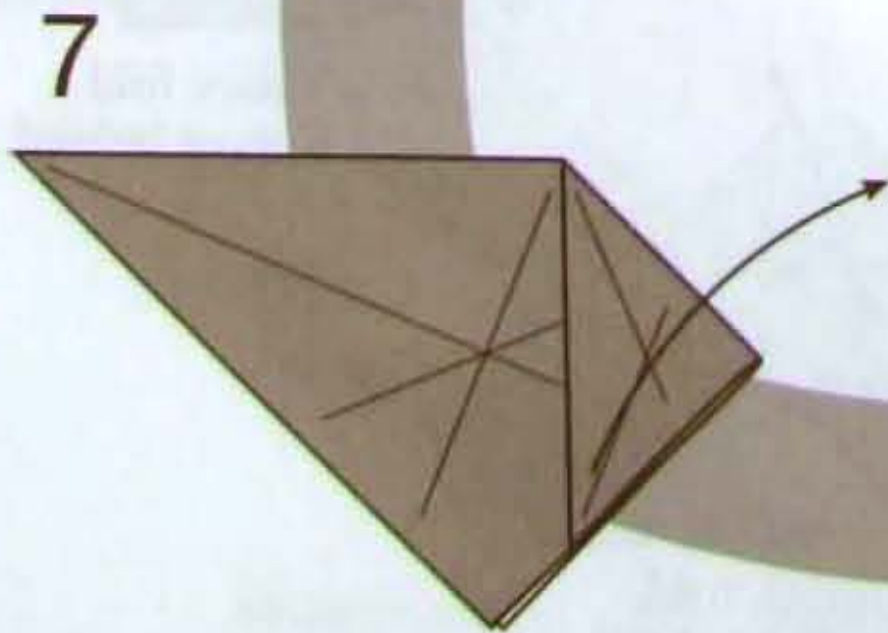
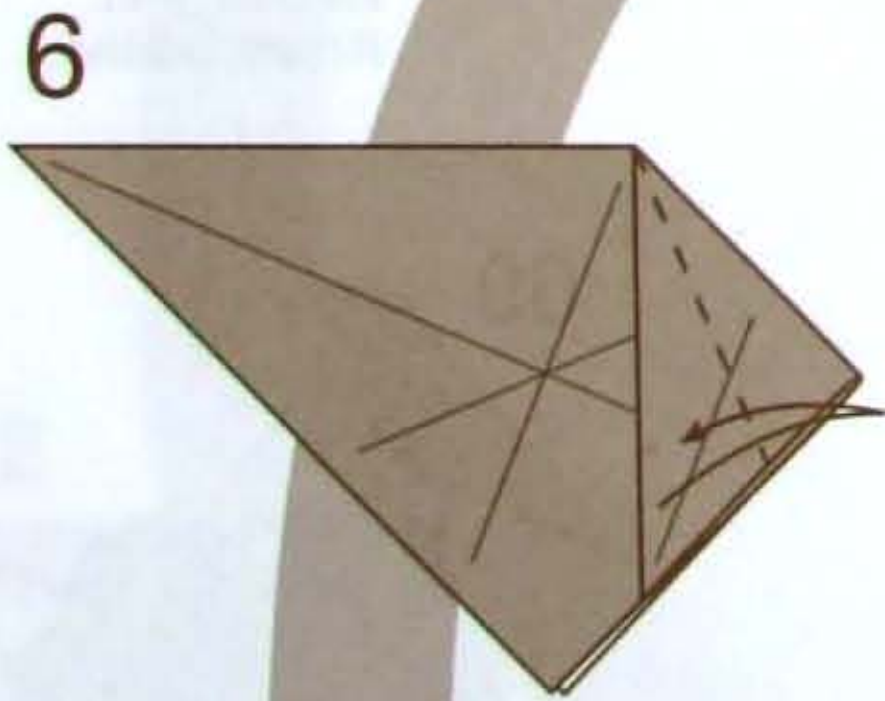
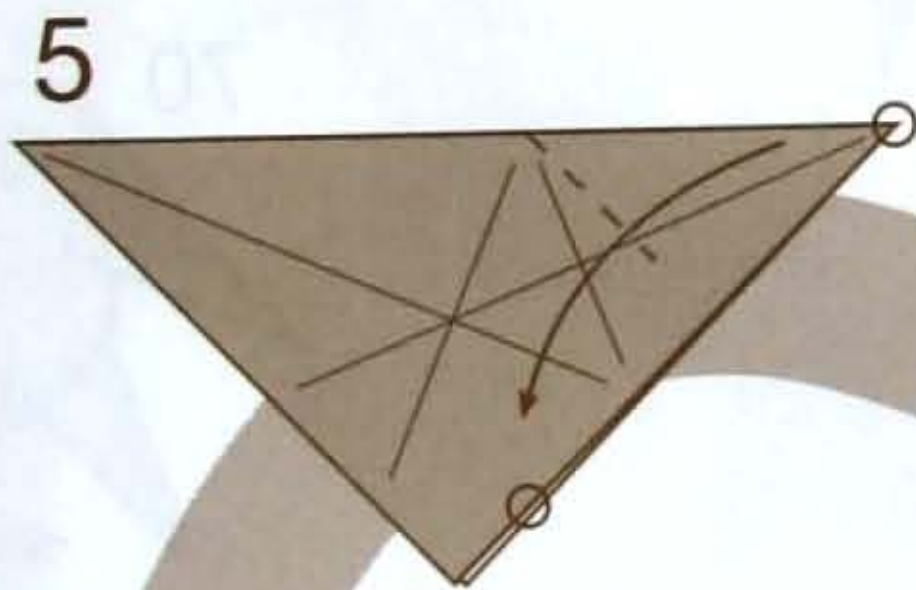
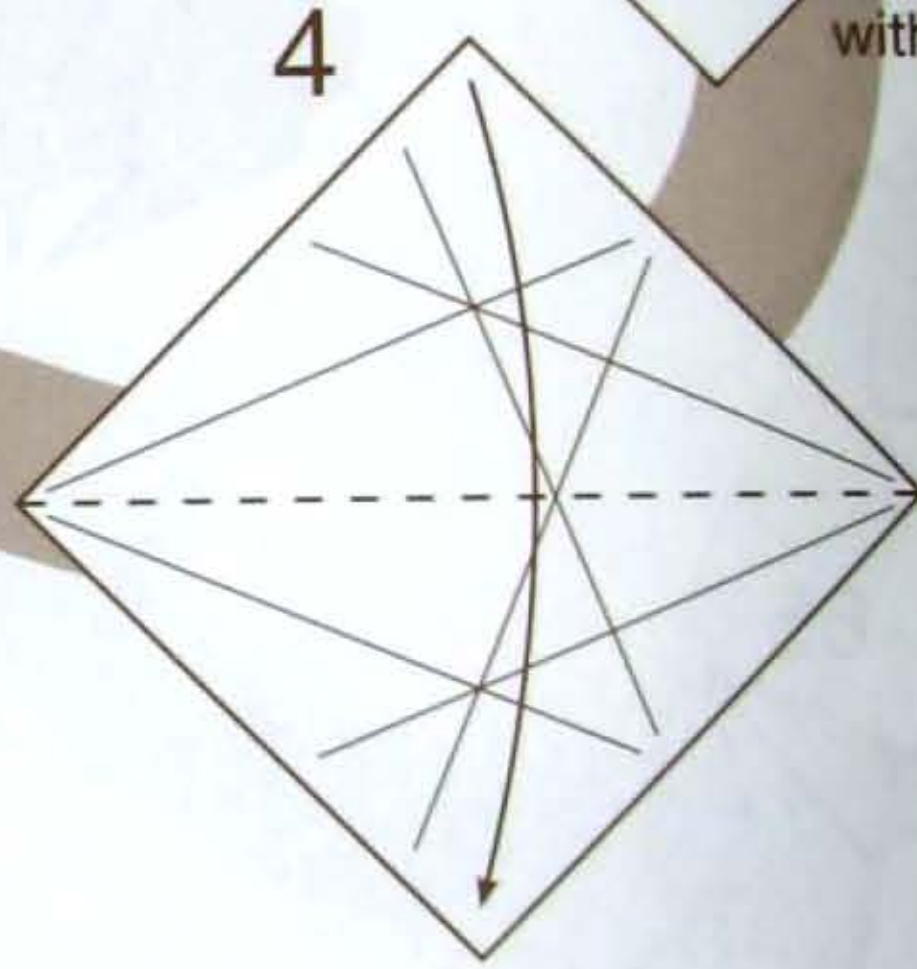

Zoom in on the corner.

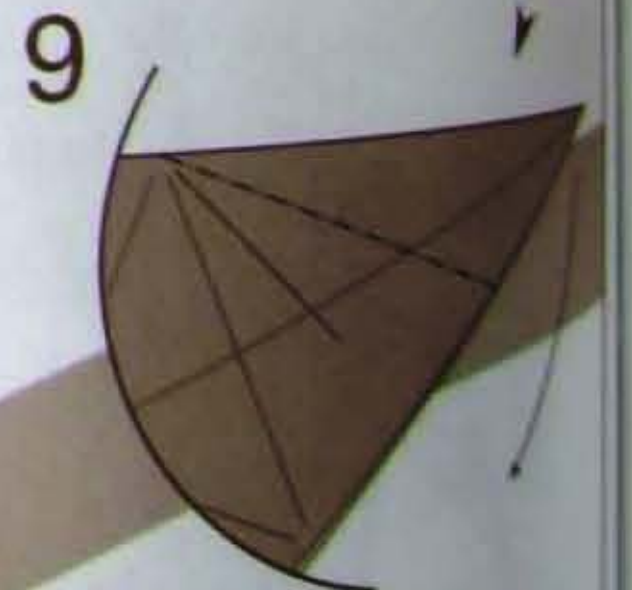

Inside reverse fold along the existing crease.

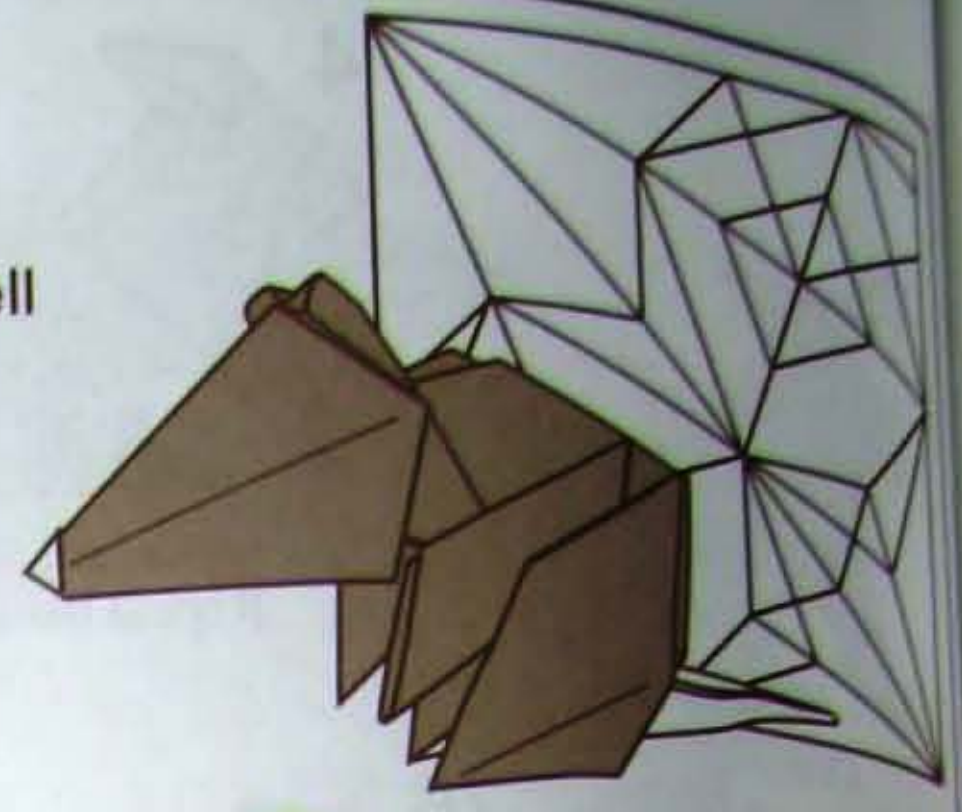

Begin colla on the top as shown.

19

18

Tuck inside Repe

36

3

Rab fold upw

第 17 回折紙

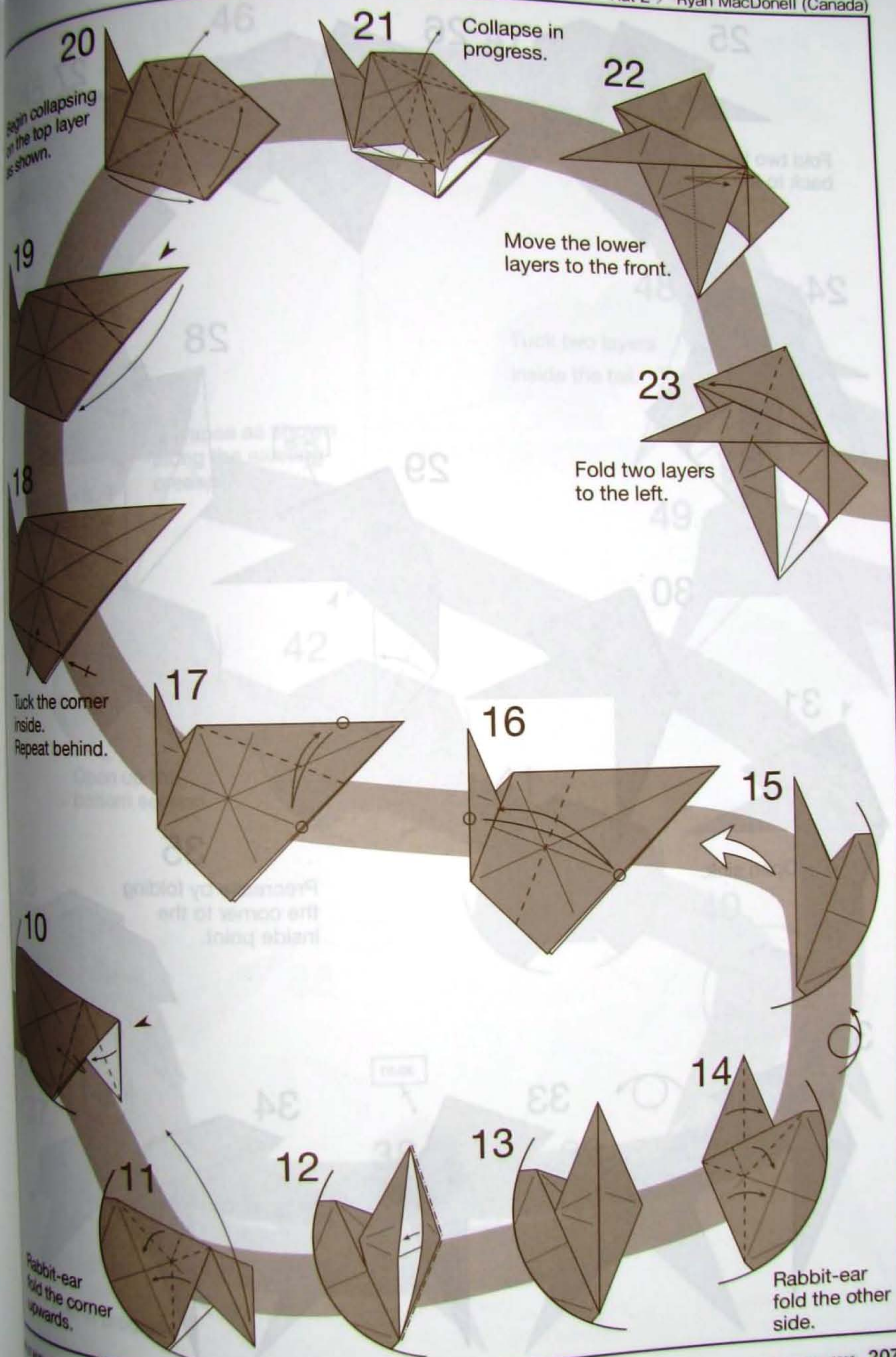

Begin collapsing on the top layer as shown.

Collapse in progress.

Move the lower layers to the front.

Fold two layers to the left.

Tuck the corner inside. Repeat behind.

Rabbit-ear fold the other side.

Rabbit-ear fold the corner upwards.

crease by the corner points shown.

reverse along the crease.

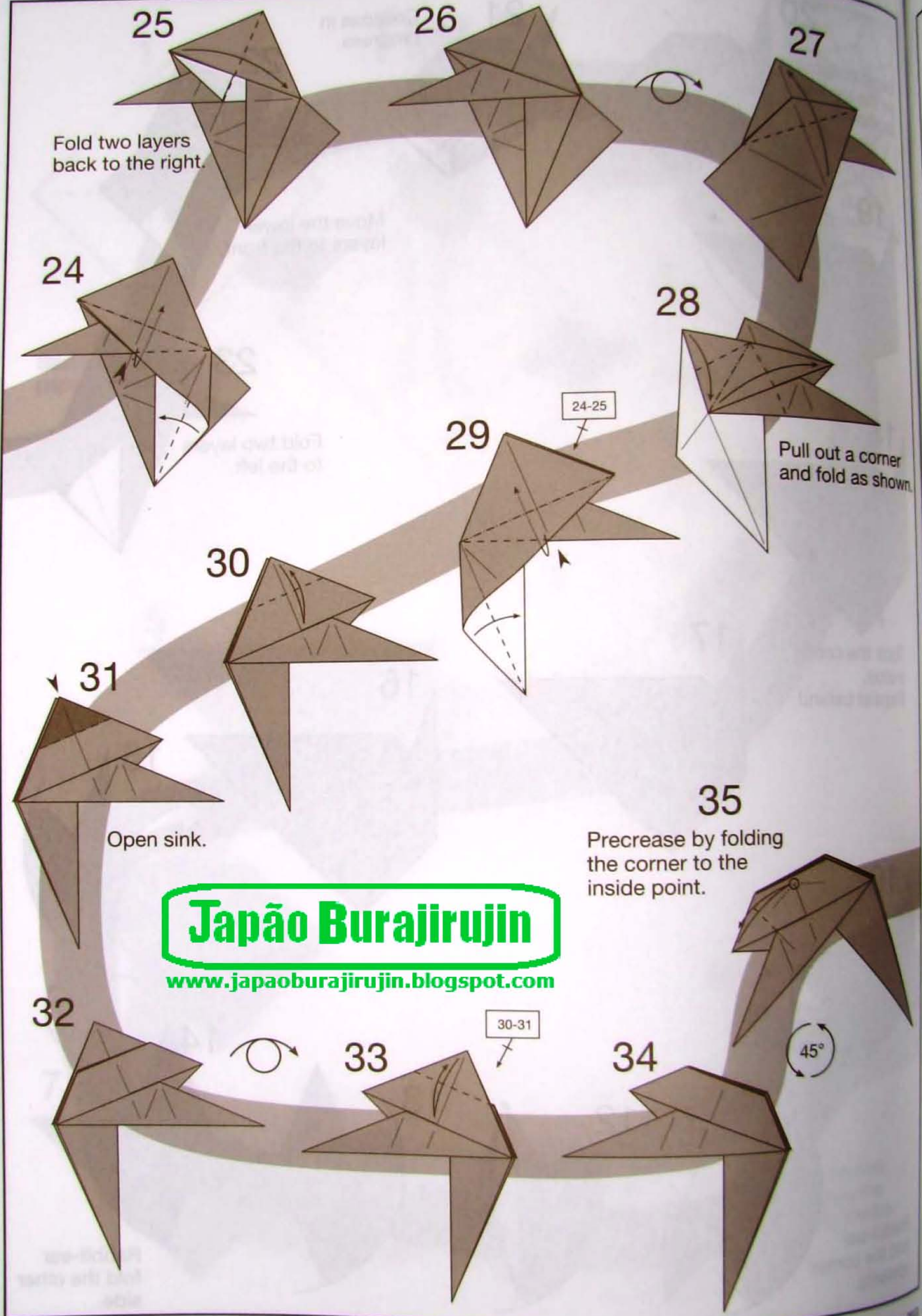

Fold two layers back to the right.

24-25

Pull out a corner and fold as shown.

Open sink.

Japão Burajirujin

www.japaoburajirujin.blogspot.com

Precrease by folding the corner to the inside point.

45°

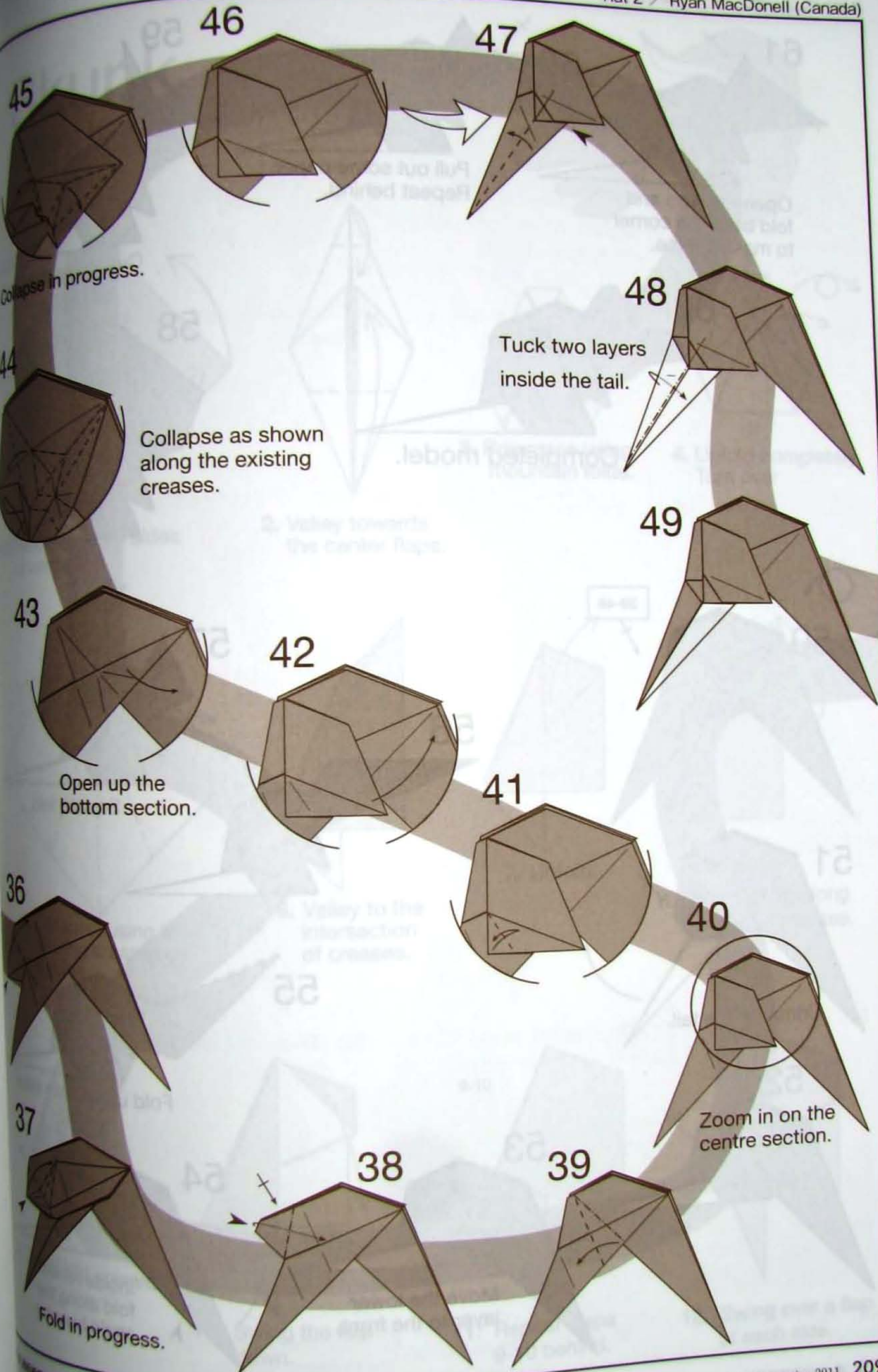

45 Collapse in progress.

44 Collapse as shown along the existing creases.

43 Open up the bottom section.

48 Tuck two layers inside the tail.

40 Zoom in on the centre section.

38 Fold in progress.

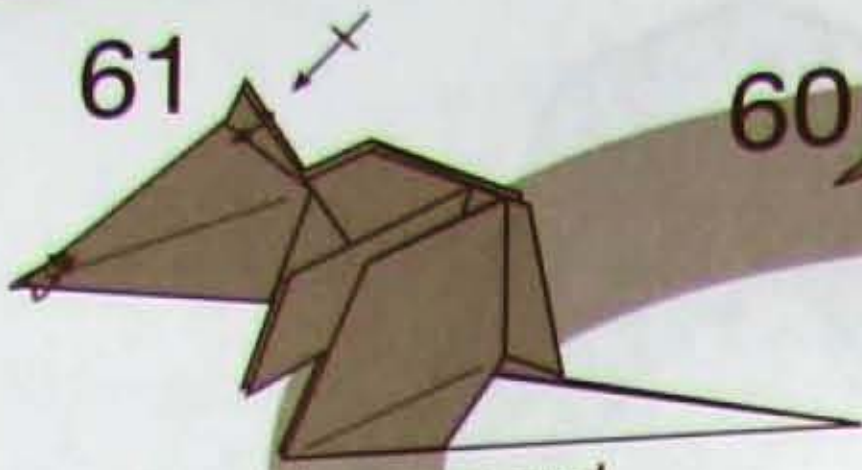

61
Open the ears and fold back the corner to make a nose.

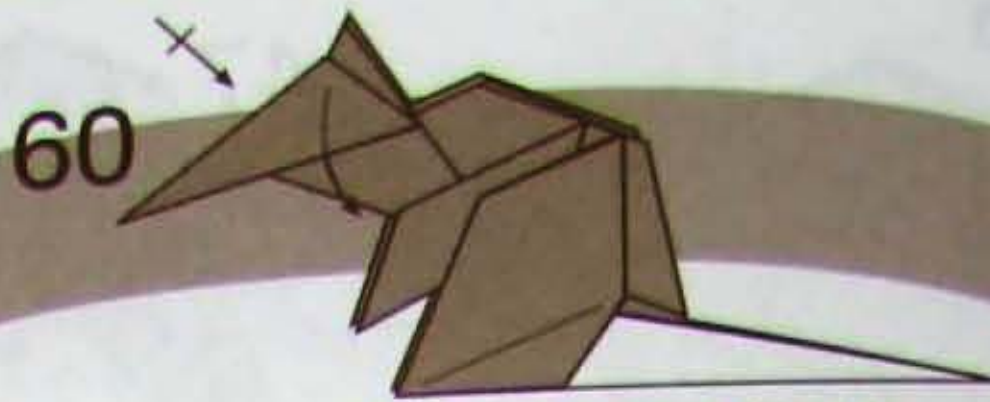

60
Pull out some paper. Repeat behind.

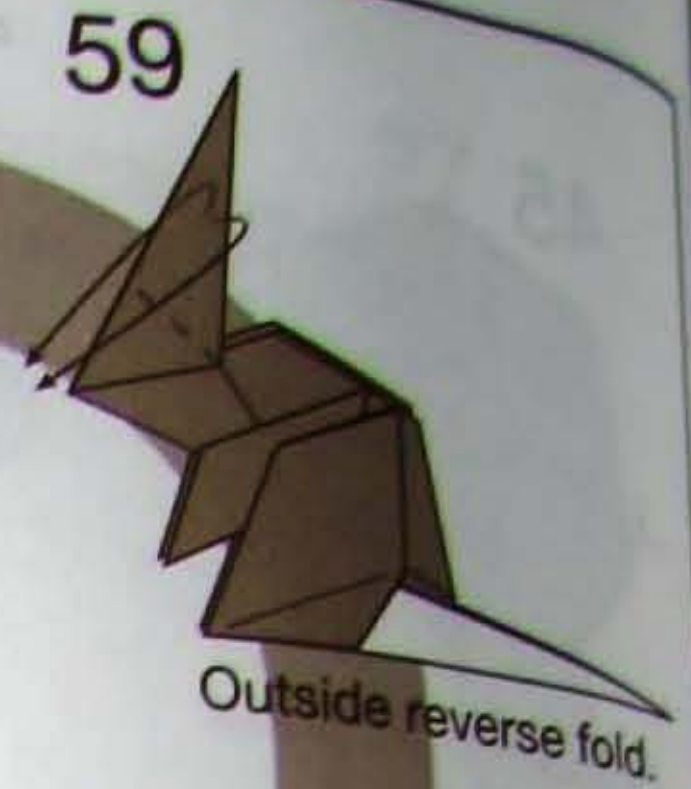

59
Outside reverse fold.

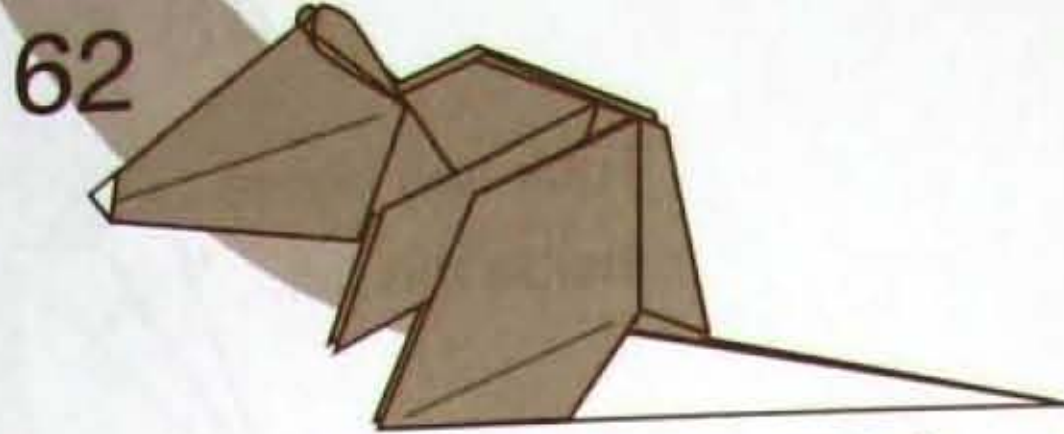

62
Completed model.

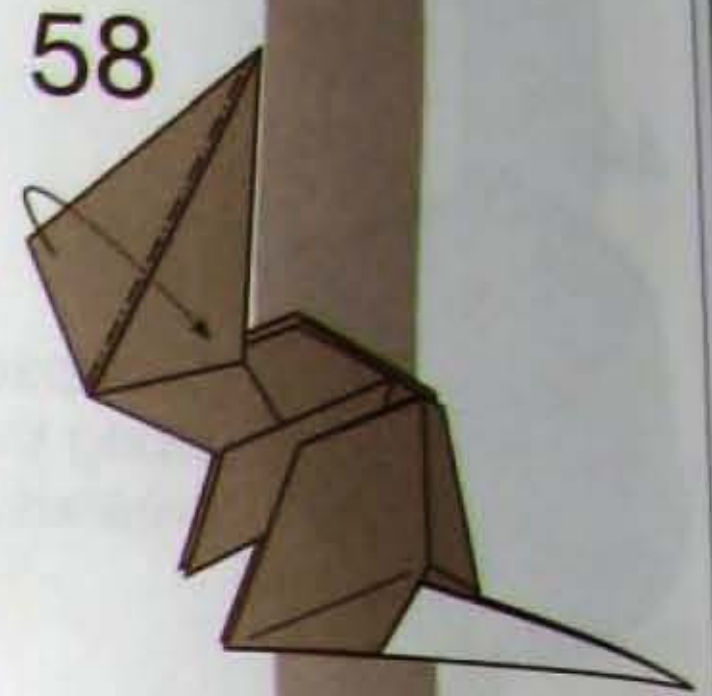

58
Squash fold.

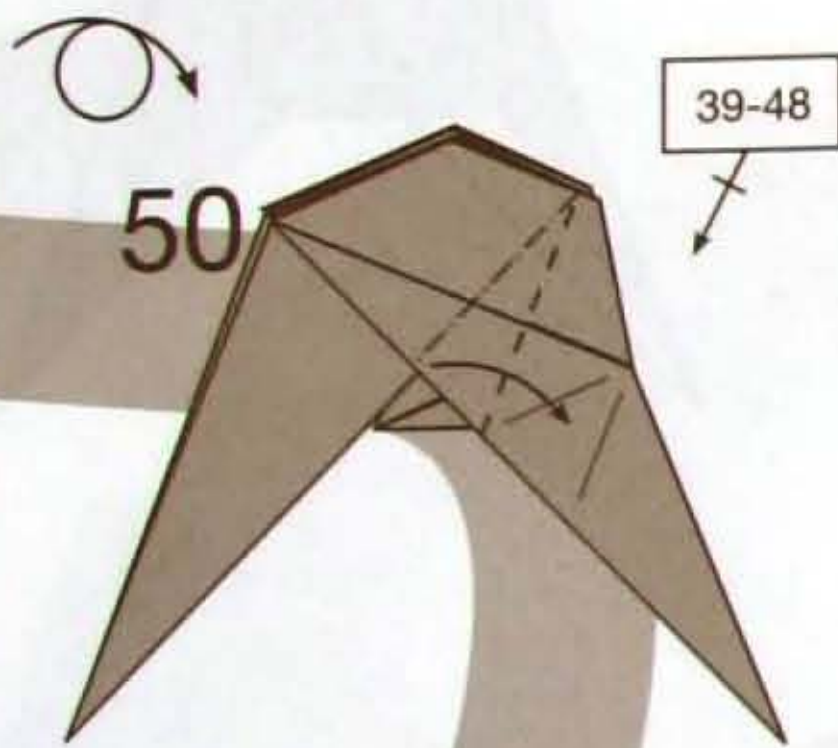

50

39-48

Crimp up the tail.

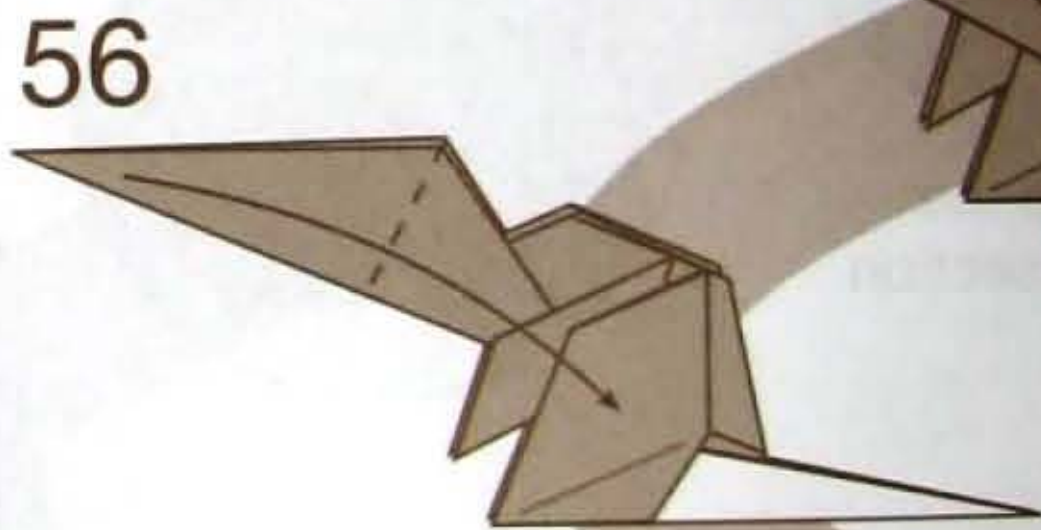

56
Squash fold.

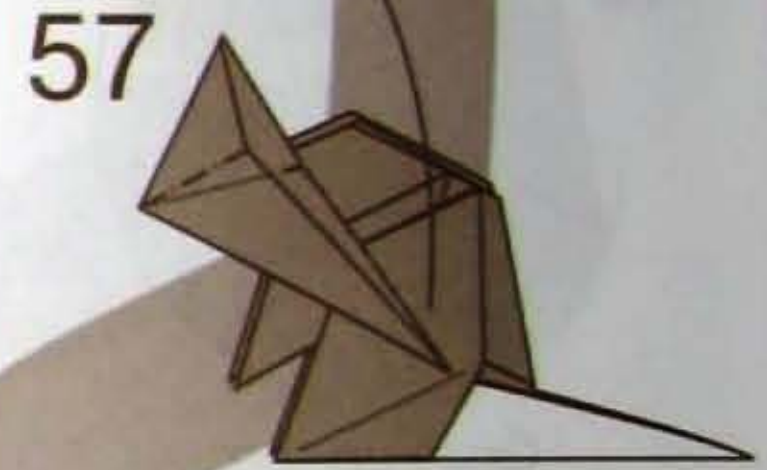

57
Squash fold.



51
Crimp up the tail.

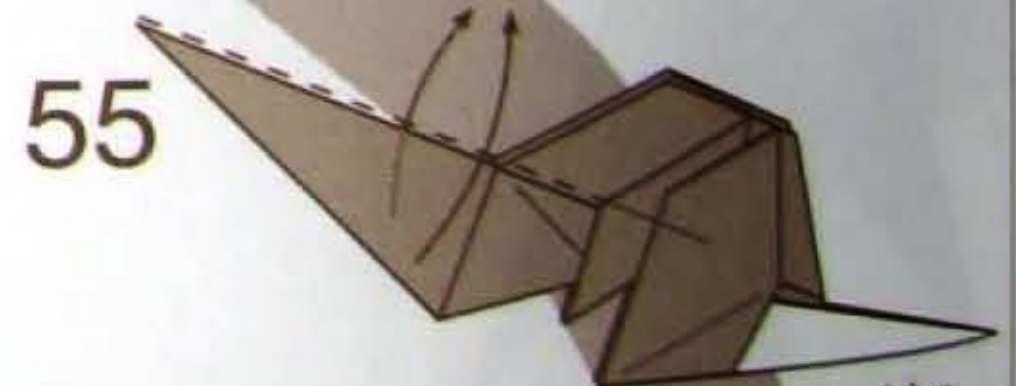

55
Fold up on both sides.

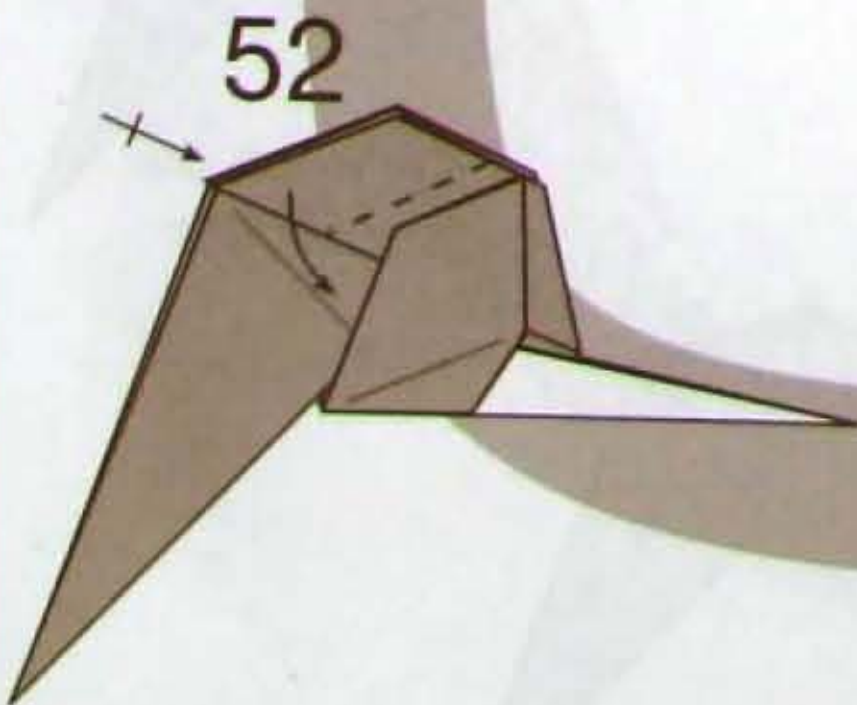

52
Crimp up the tail.

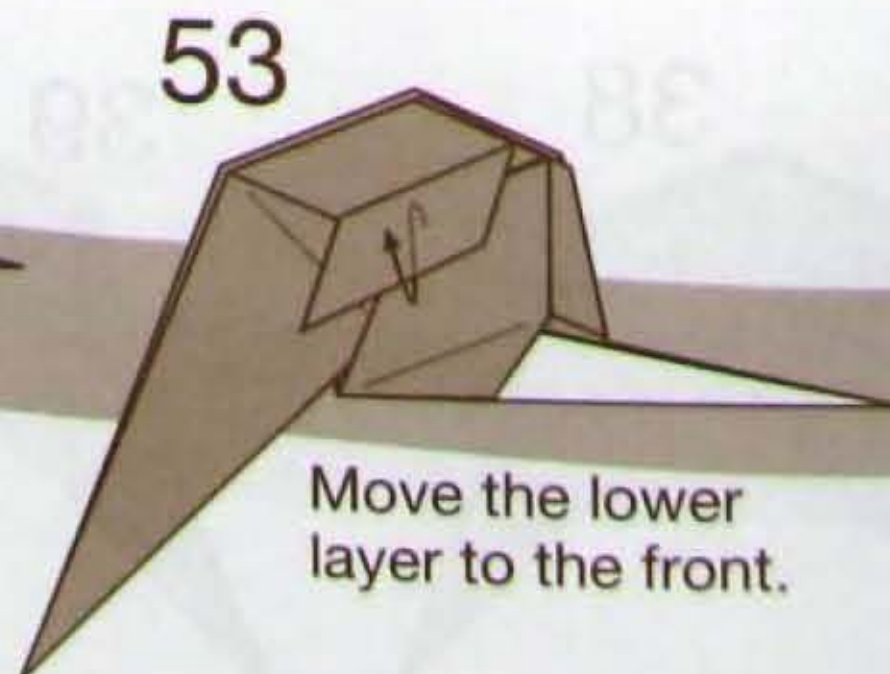

53
Move the lower layer to the front.



54
Inside reverse fold along the angle bisector.

Skunk

by Marc Kirschenbaum ©1994

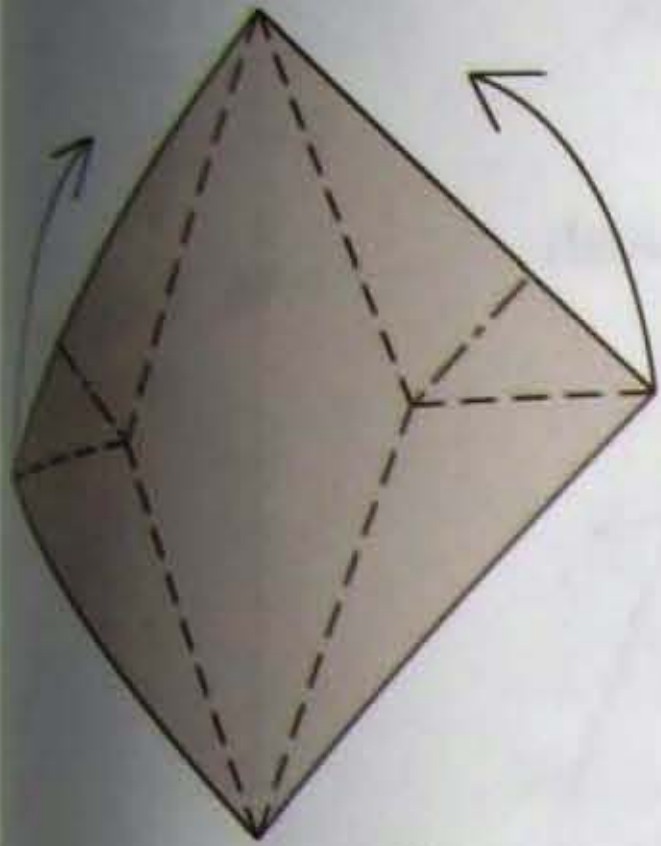
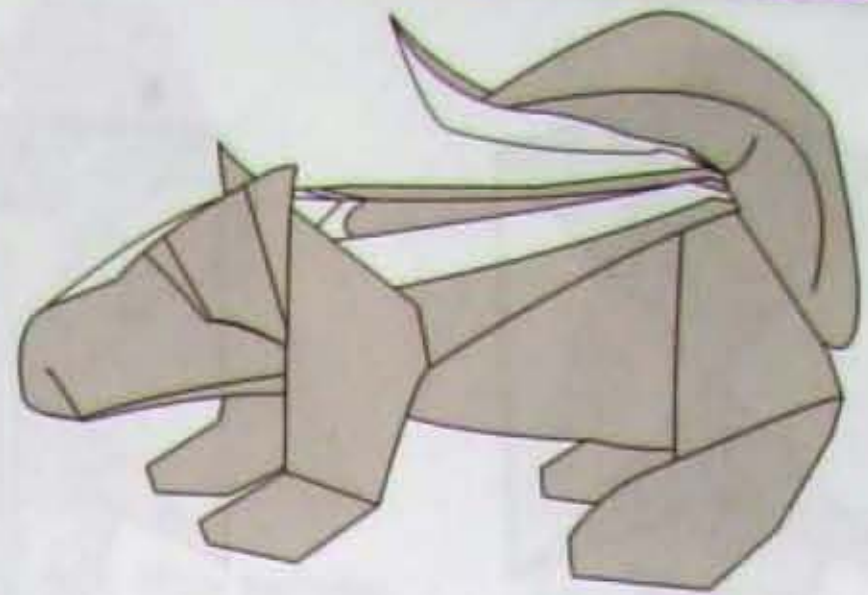

1. Rabbit ear both sides upwards.

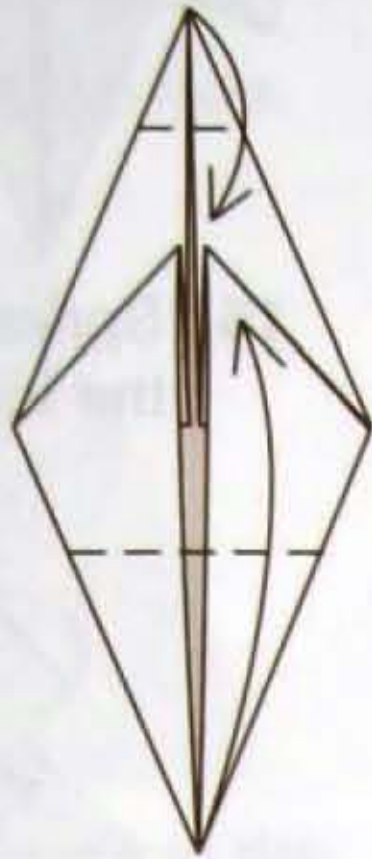

2. Valley towards the center flaps.

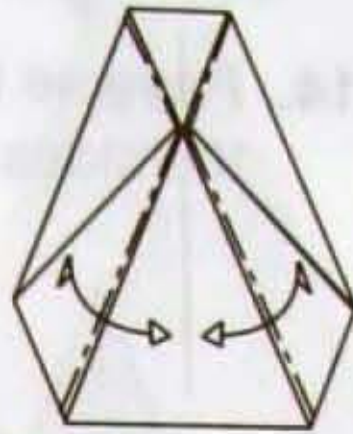

3. Precrease using mountain folds.

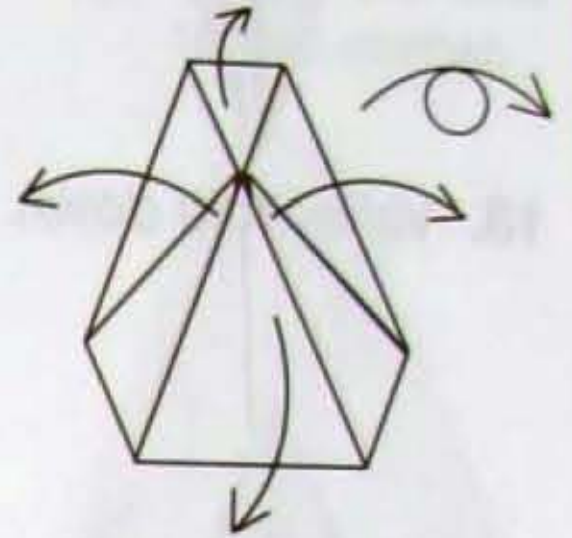

4. Unfold completely. Turn over

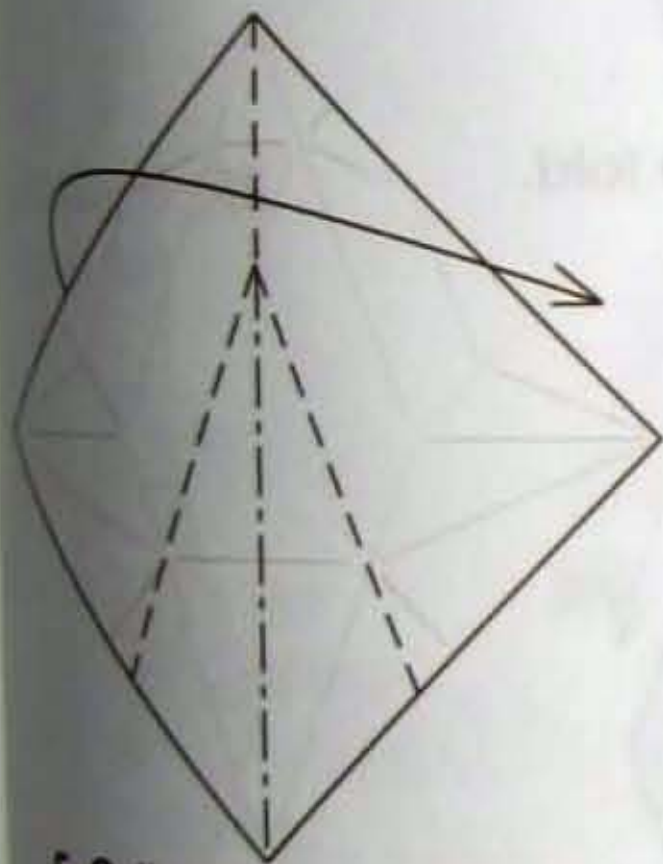

5. Collapse, using the existing creases as a guide.

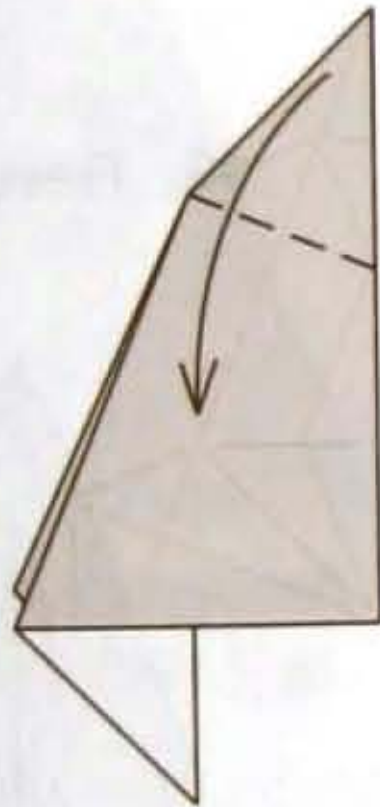

6. Valley to the intersection of creases.

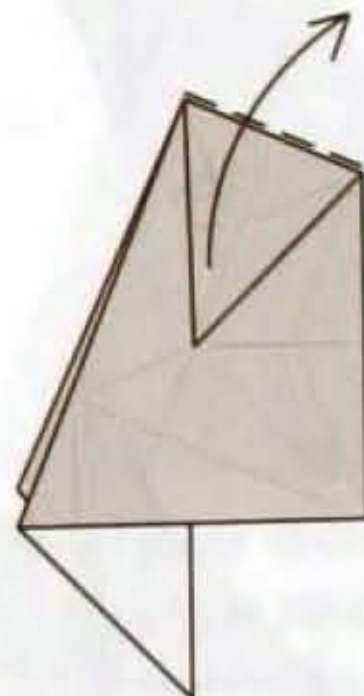

7. Unfold.

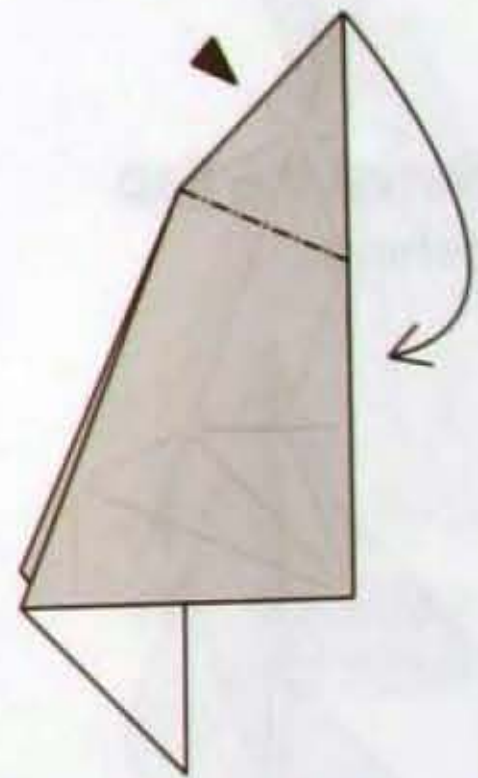

8. Reverse fold along the existing crease.

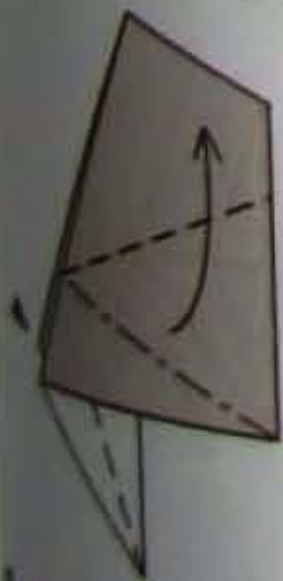

9. Swivel fold upwards.

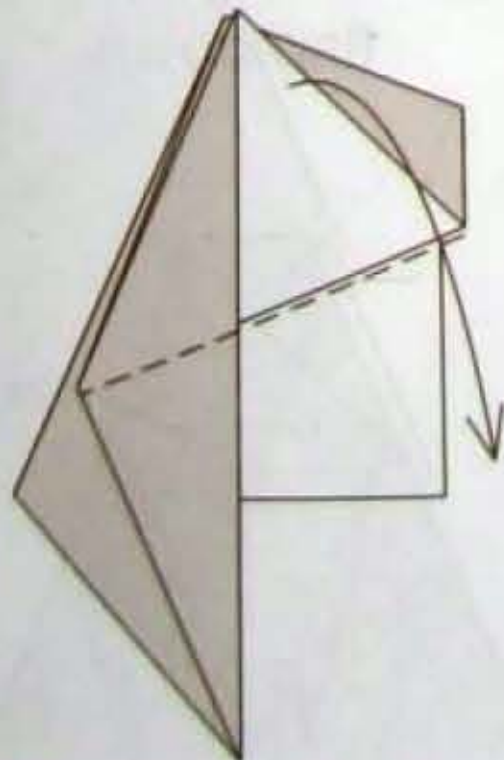

10. Swing the flap down.

9-10

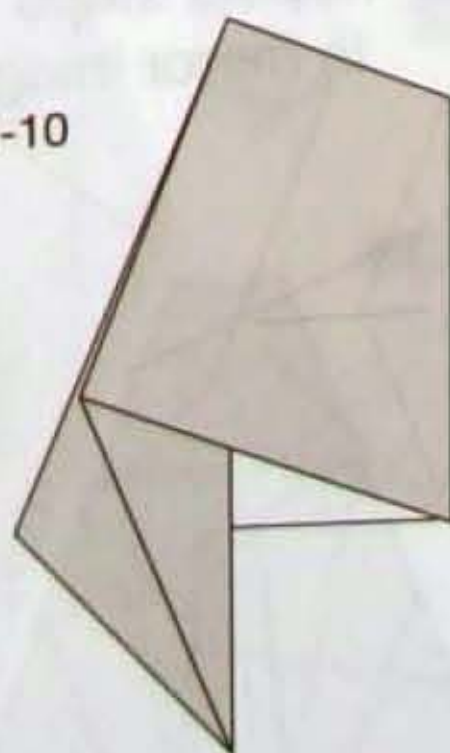

11. Repeat steps 9-10 behind.

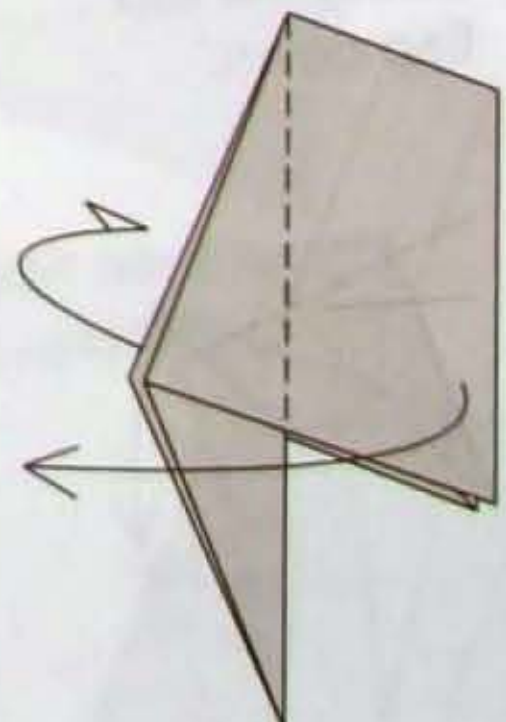

12. Swing over a flap at each side.

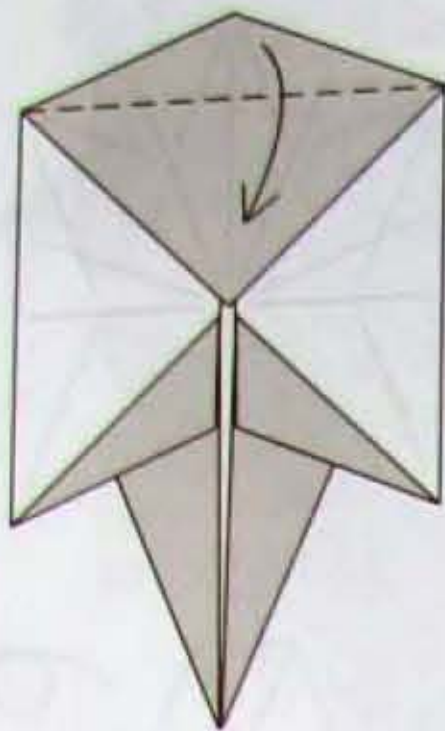

13. Valley fold down.

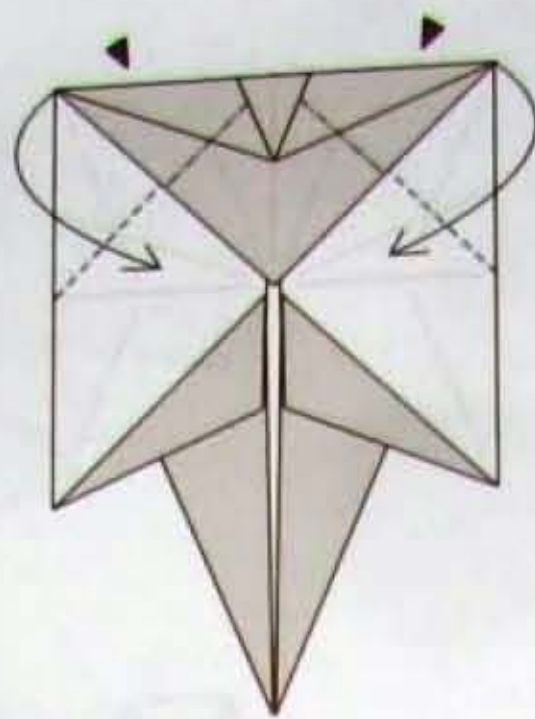

14. Reverse fold the sides.

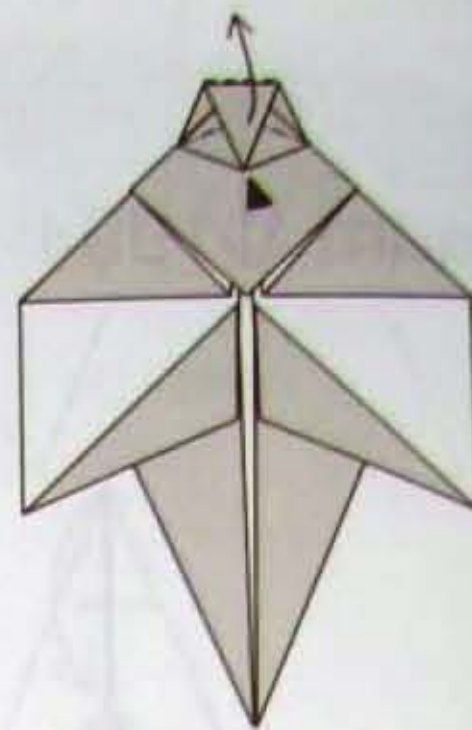

15. Spread squash the top.

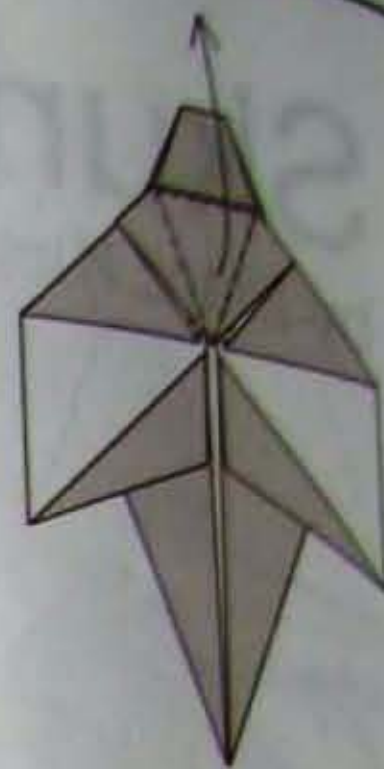

16. Petal fold upwards.

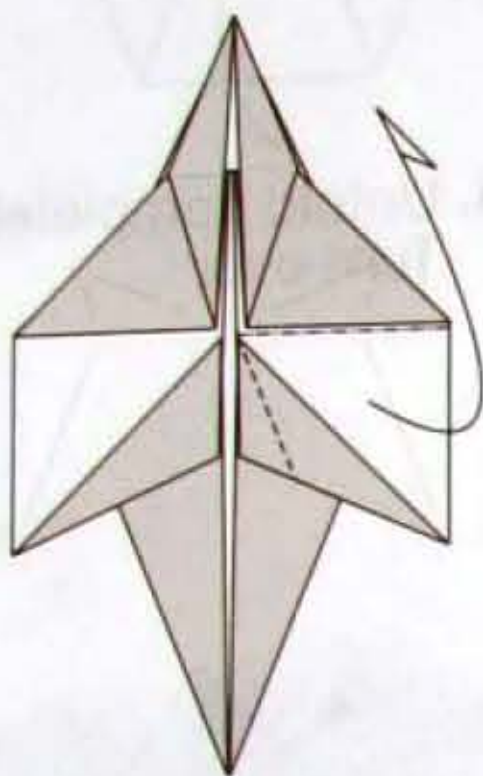

17. Swivel the flap behind.

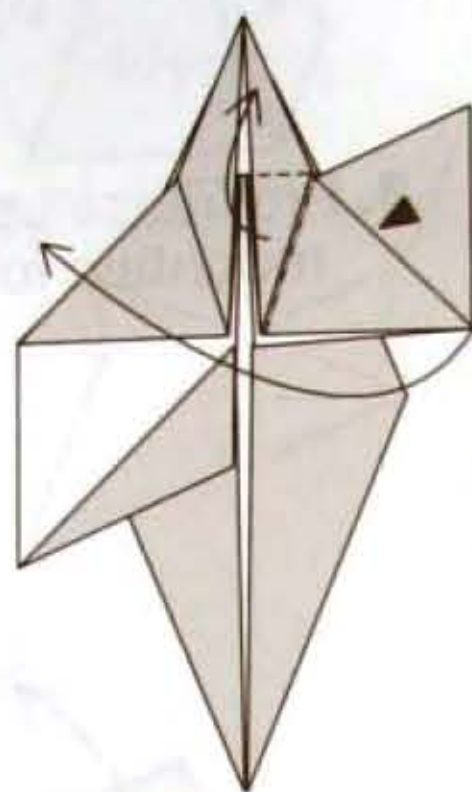

18.

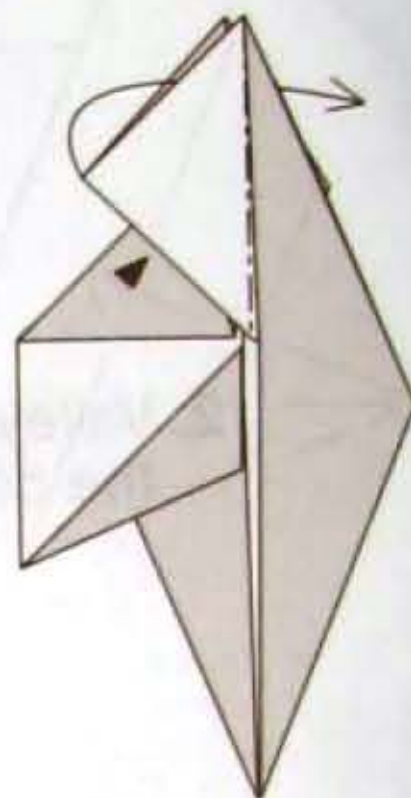

19. Reverse fold.

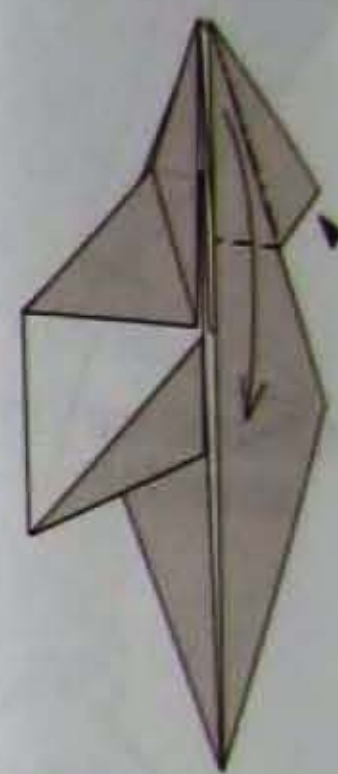

20. Squash the flap down.

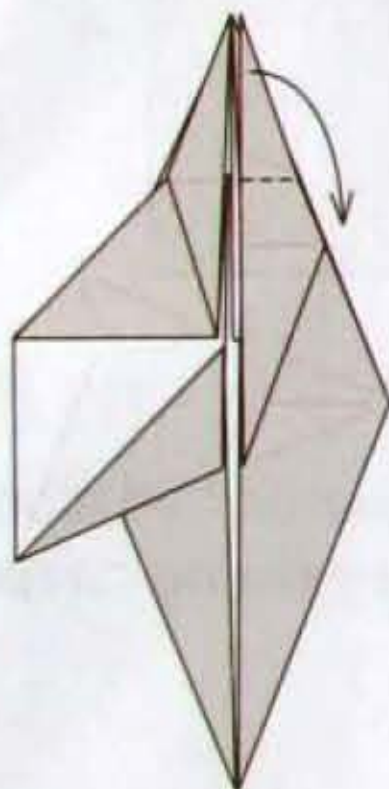

21. Swing the top flap down.

17-21

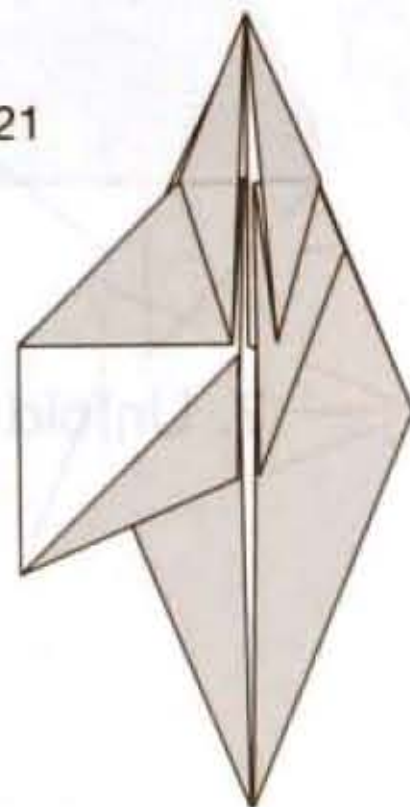

22. Repeat steps 17-21 in mirror image.

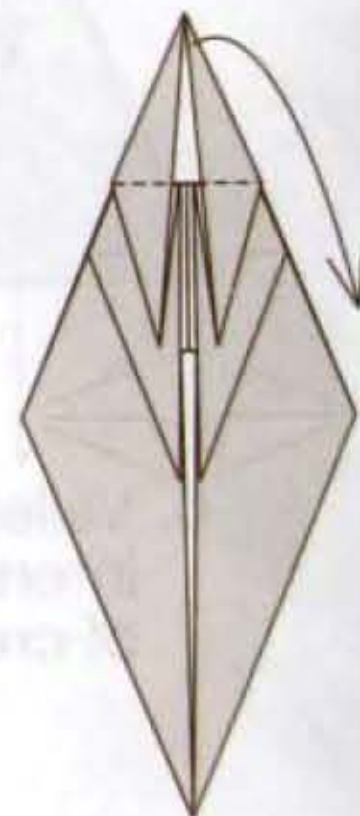

23. Swing the top flap down.



24. Valley fold up.

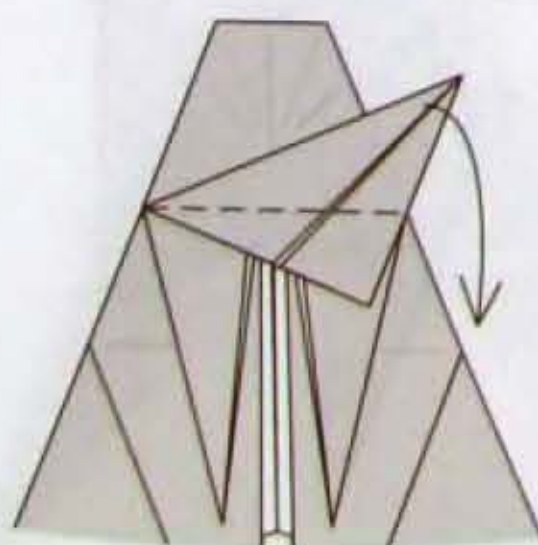

25. Valley fold down.

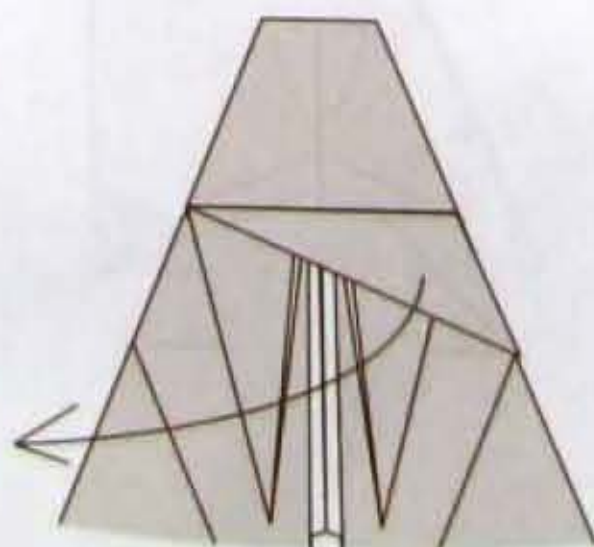

26. Unfold the pleat.

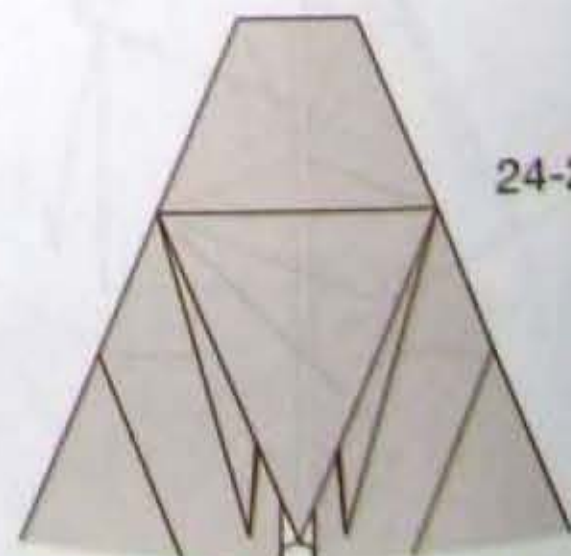

27. Repeat steps 24-26 in mirror image.

24-26

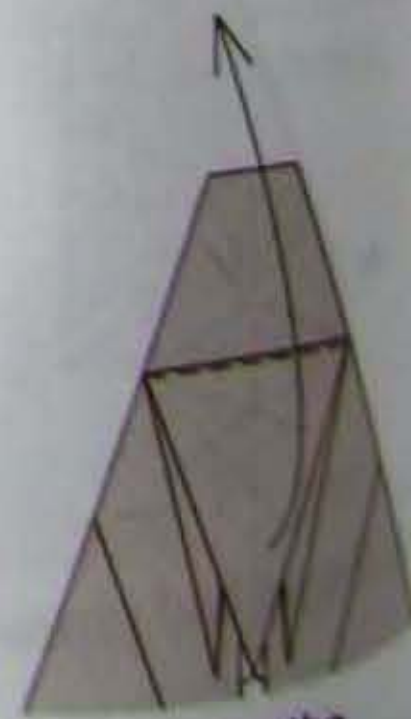

28. Swing the flap up.

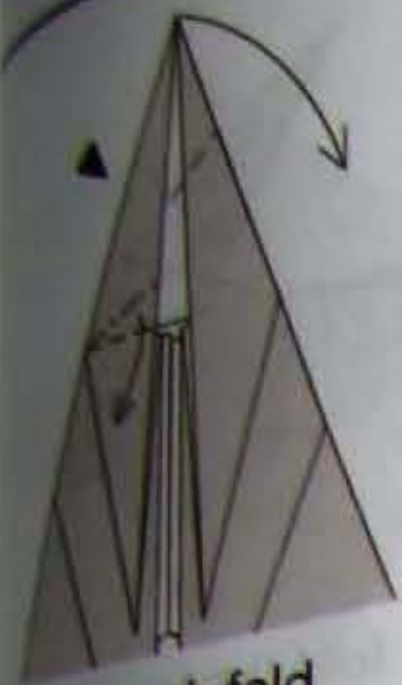

29. Squash fold.

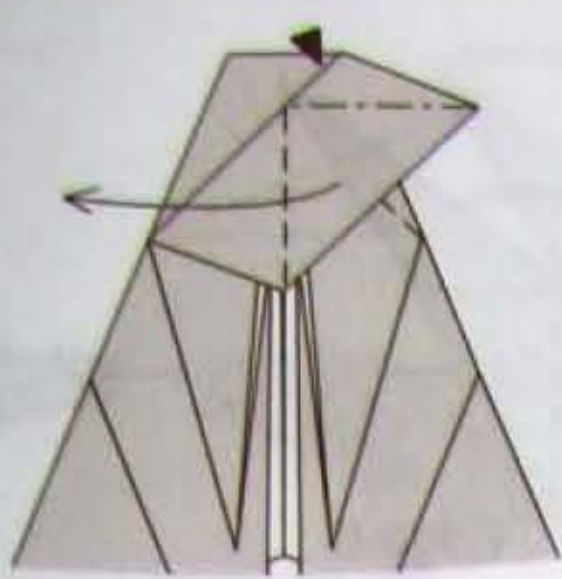

30. Squash over.

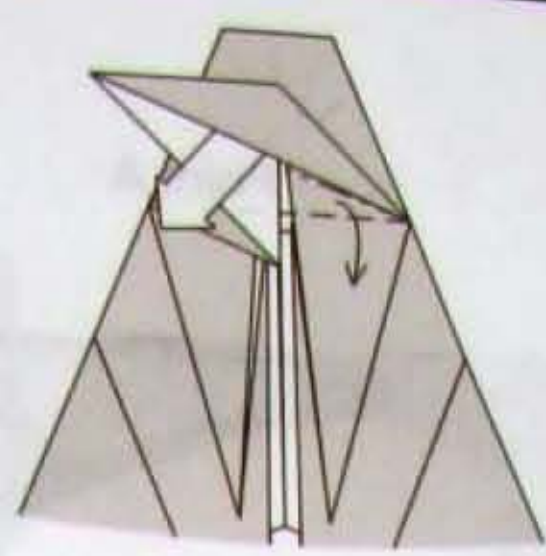

31. Pull out the single layer to match the other side.

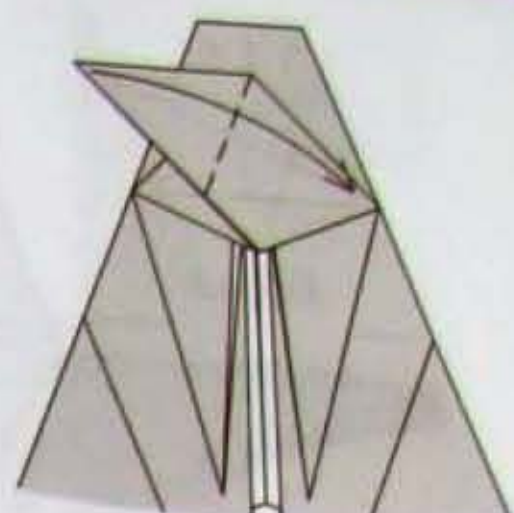

32. Valley fold over to the corner.



33. Valley fold over.

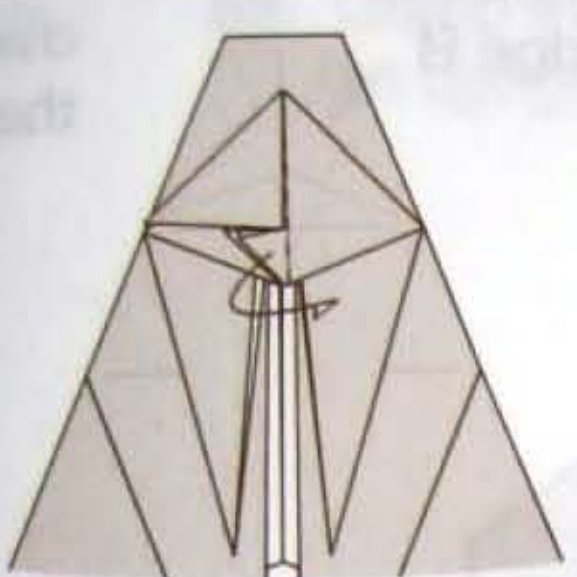

34. Mountain fold the small flap into the pocket.

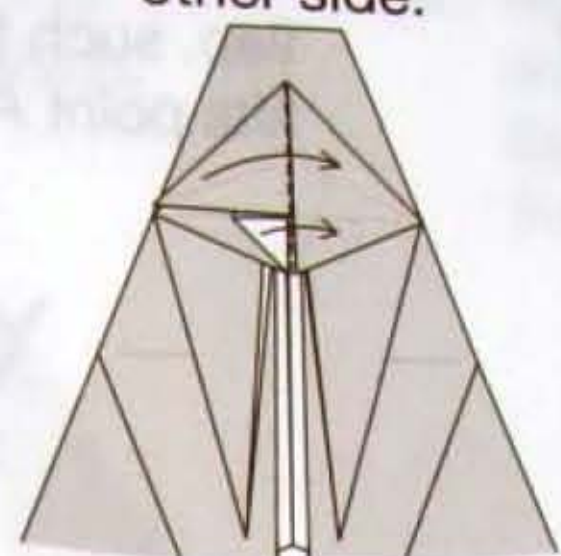

35. Swing over two flaps.

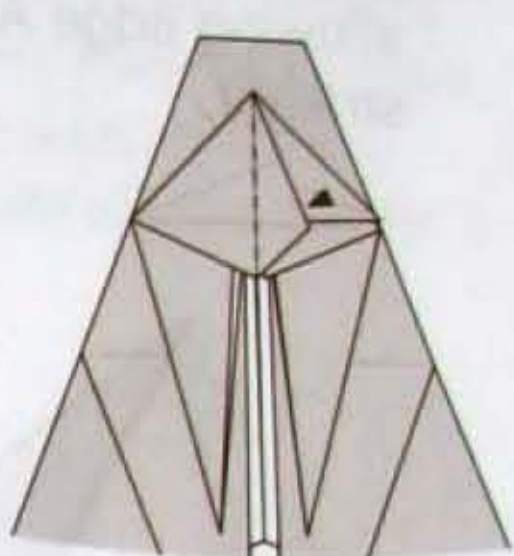

36. Reverse fold the flap through to match the other side.

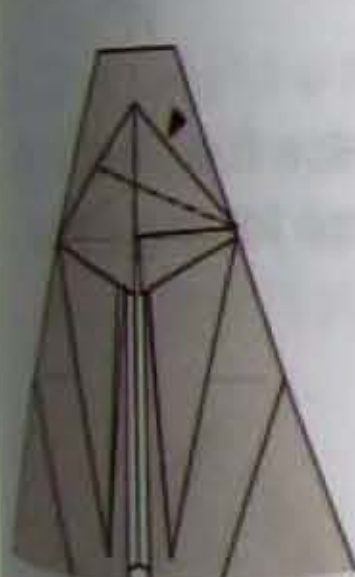

37. Sink the center flap, being careful not to let its pleats come undone.

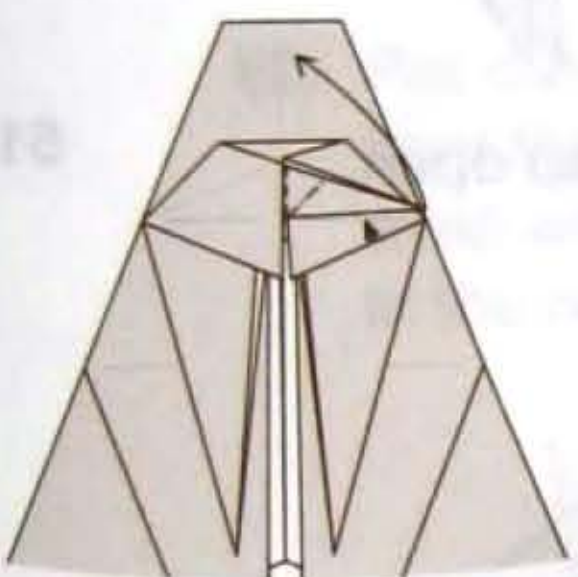

38. Spread squash the center flap.

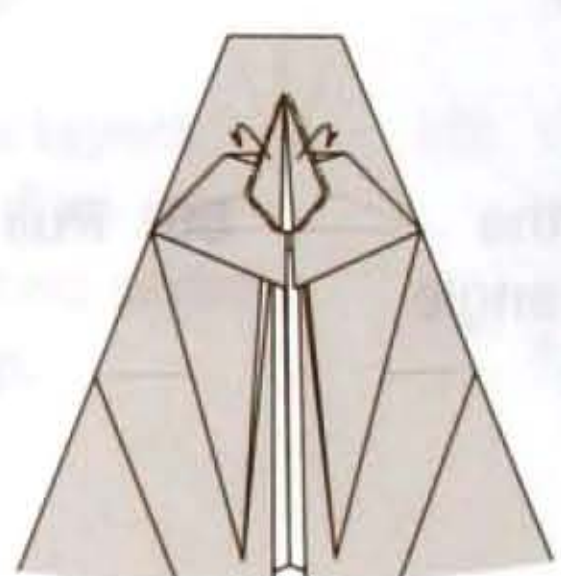

39. Wrap around a single layer at each side.

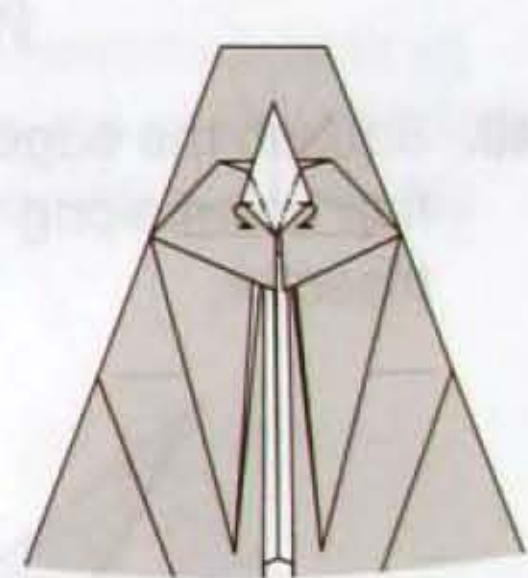

40. Mountain fold the lower edges.



41. Mountain fold the sides.

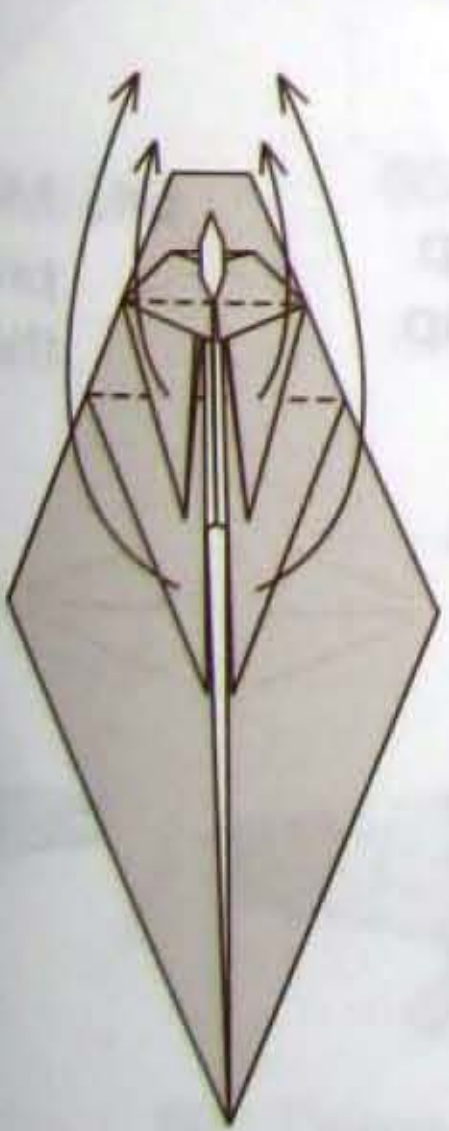

42. Swing the indicated sets of flaps upwards.

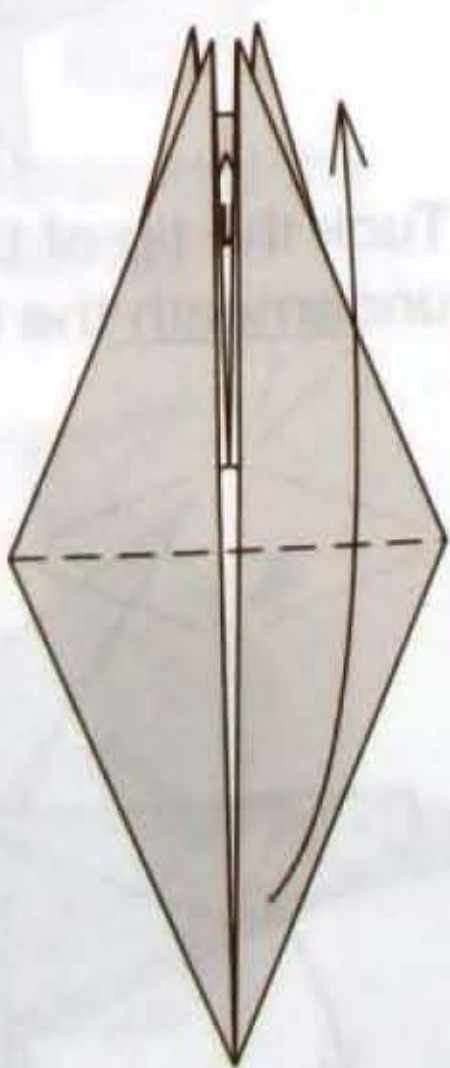

43. Valley fold the flap upwards. Rotate the model 1/4 turn.

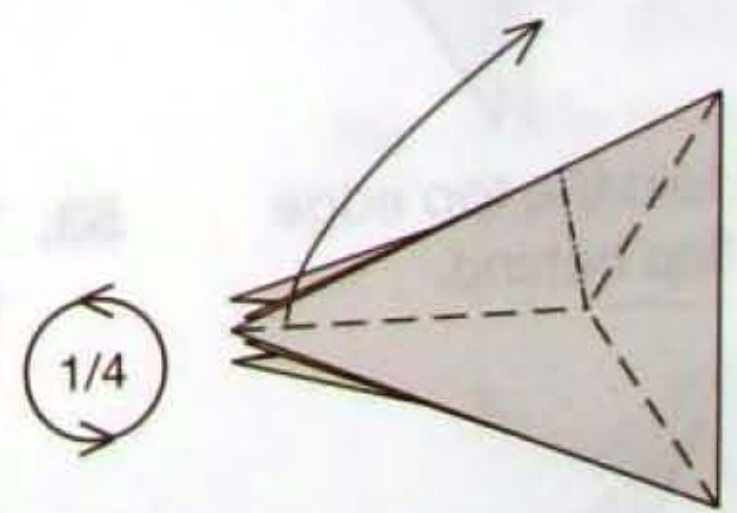

44. Rabbit ear the flap upwards.

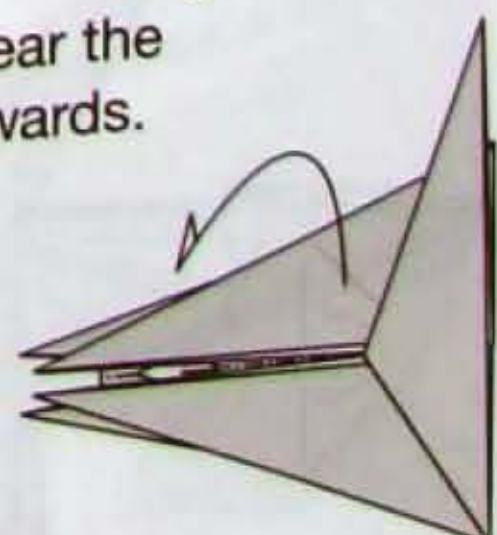

45. Mountain fold the model in half.

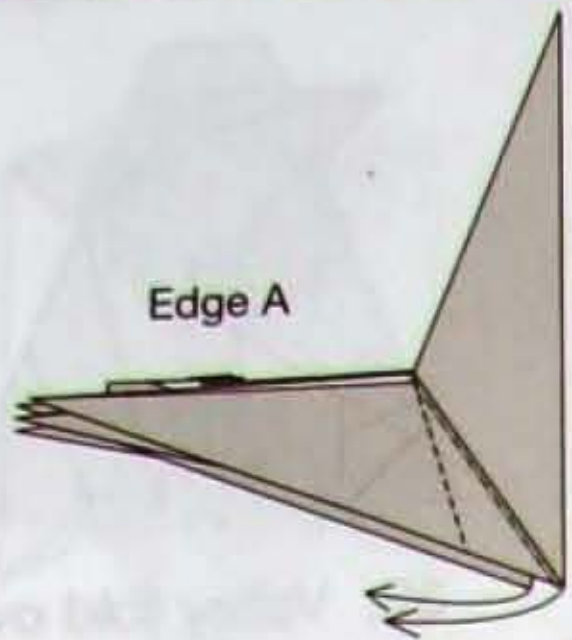

46. Crimp the back section, allowing edge A to lie straight.

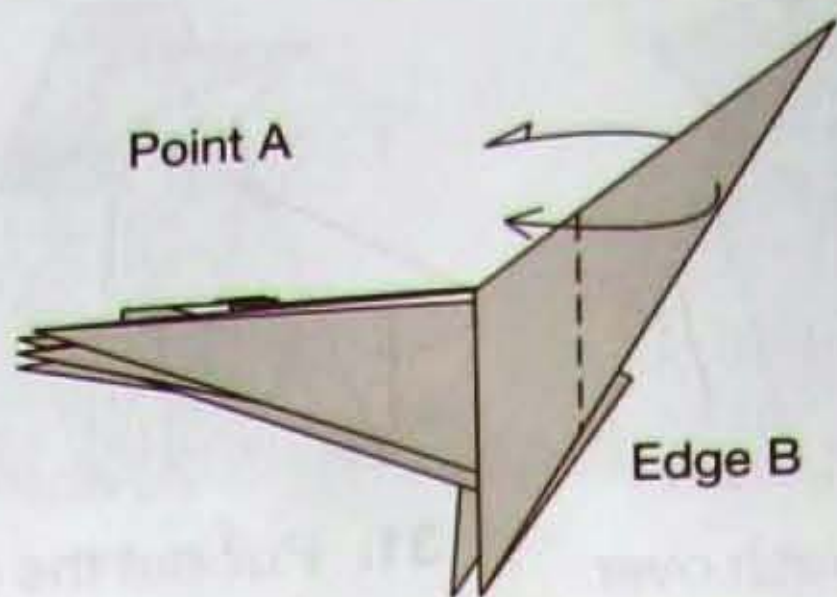

47. Outside reverse fold the flap, such that edge B hits point A.

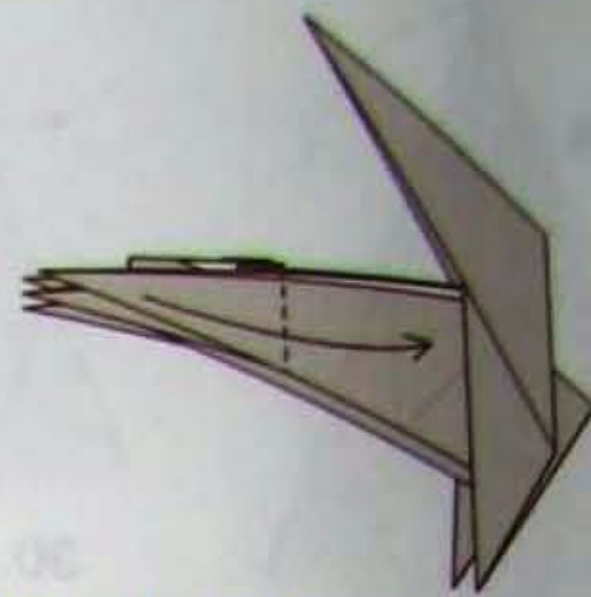

48. Valley fold the top flap over, at the point where the head flap begins.

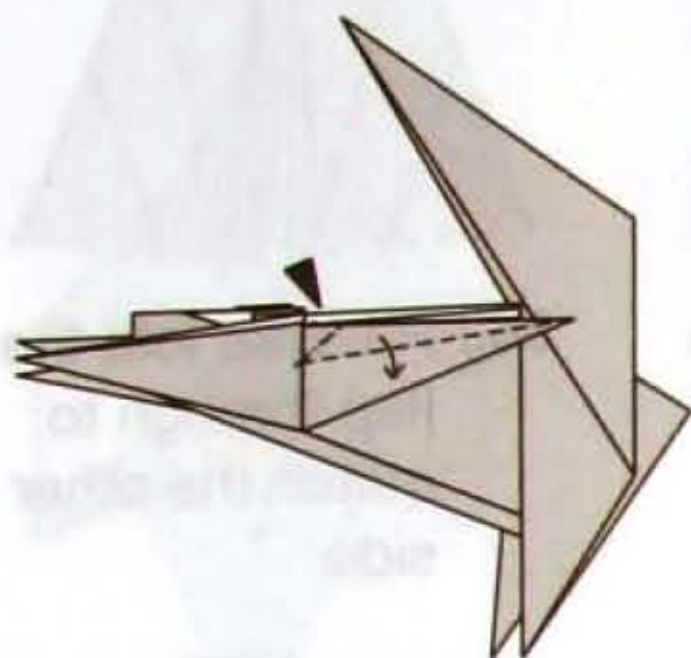

49. Squash the edge of the flap down along the angle trisector.

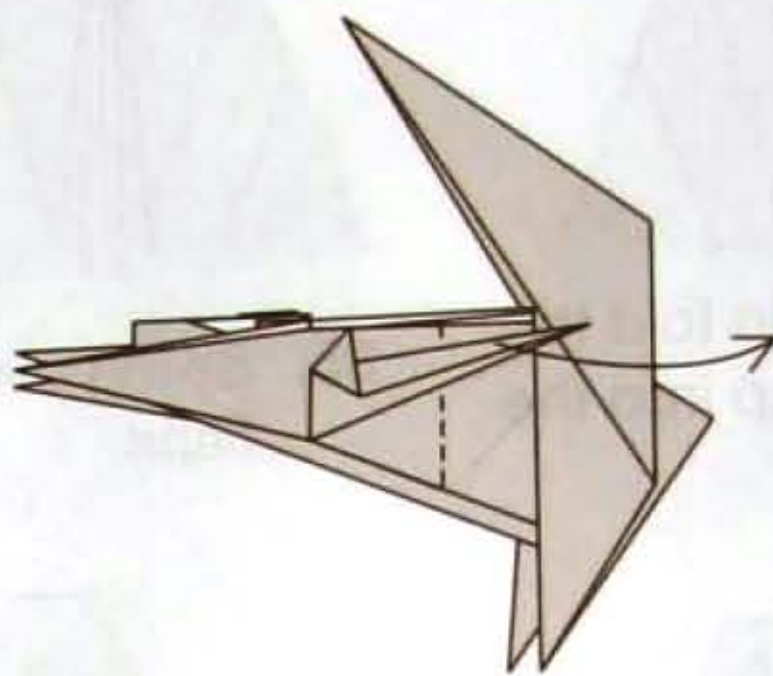

50. Pull the flap open.

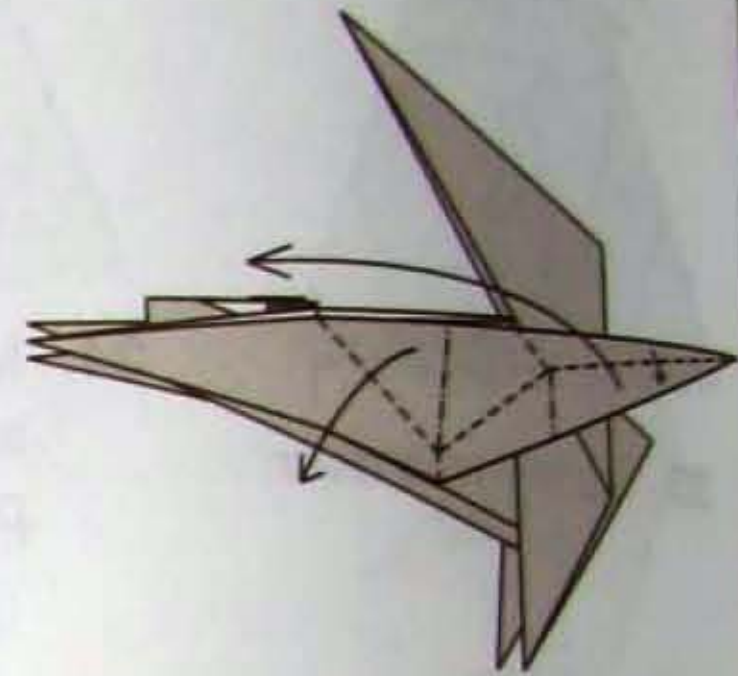

51. Replace the pleat, while reverse folding the top layer.

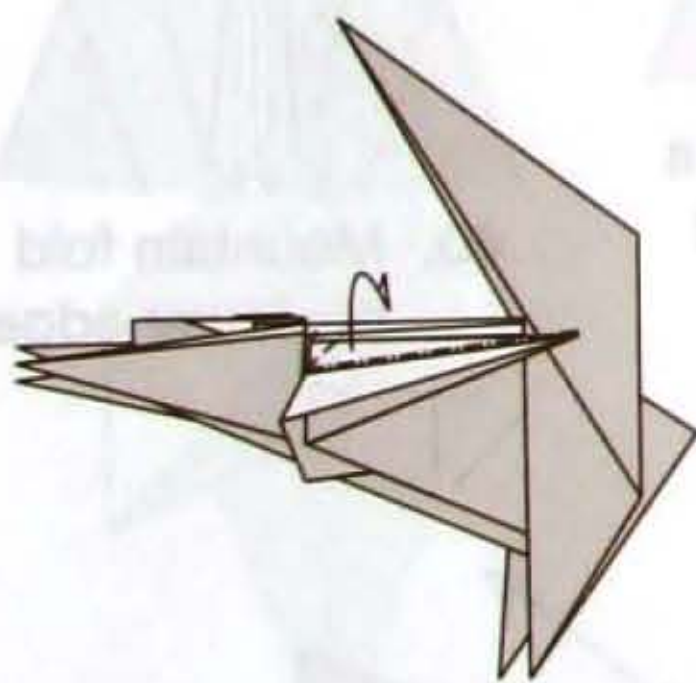

52. Swivel fold the top edge of the flap behind.

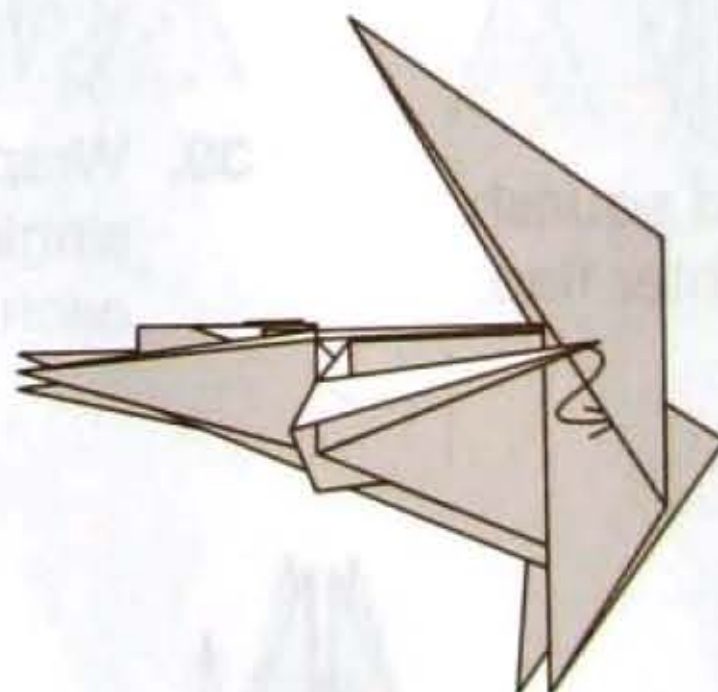

53. Tuck the tip of the flap underneath the tail flap.

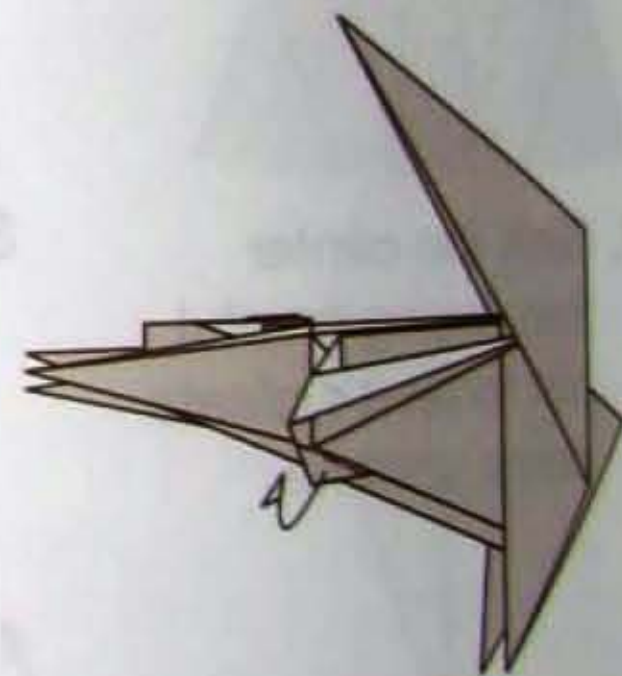

54. Mountain fold the protruding section into the model.

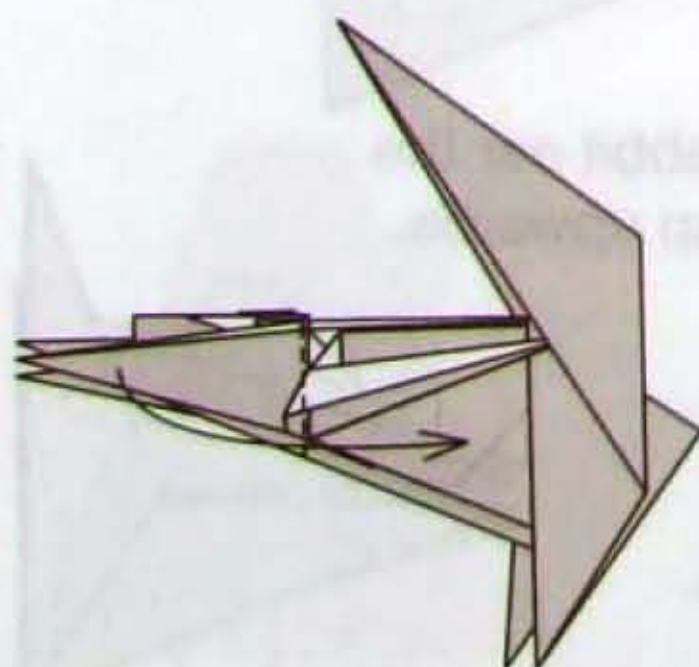

55. Swing over one flap.

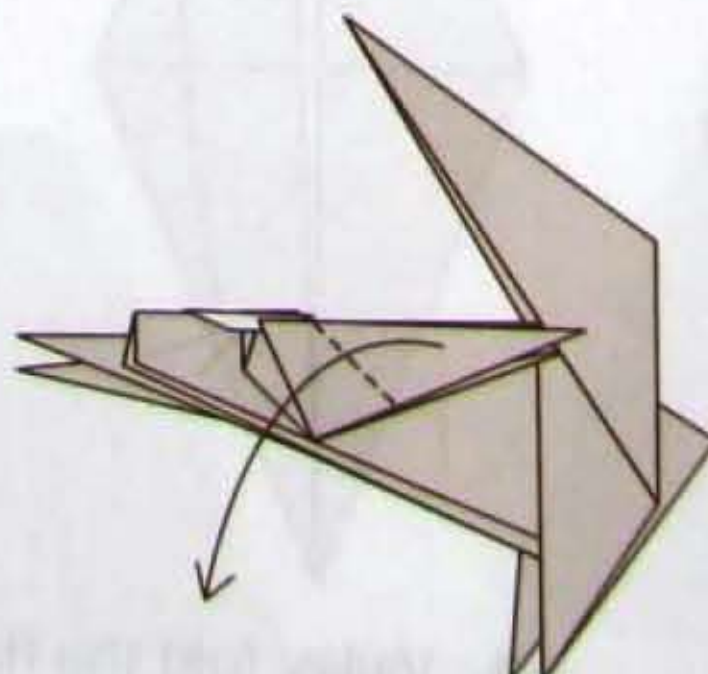

56. Valley fold the flap down.

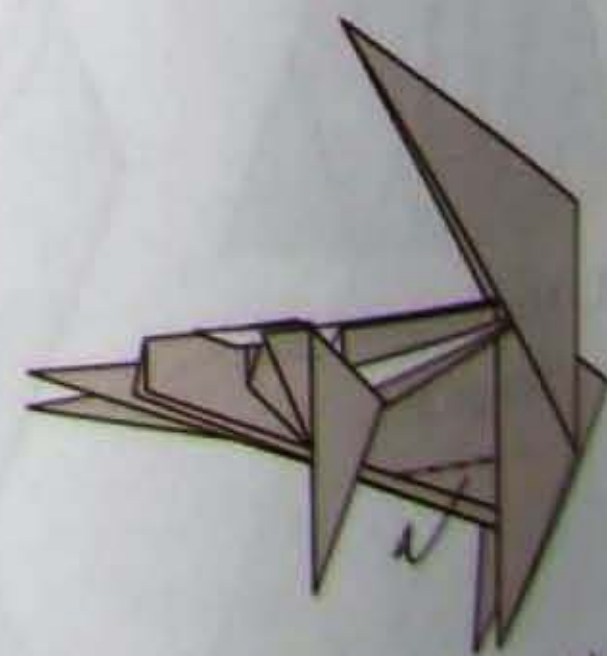

57. Swivel fold the double layered side under.

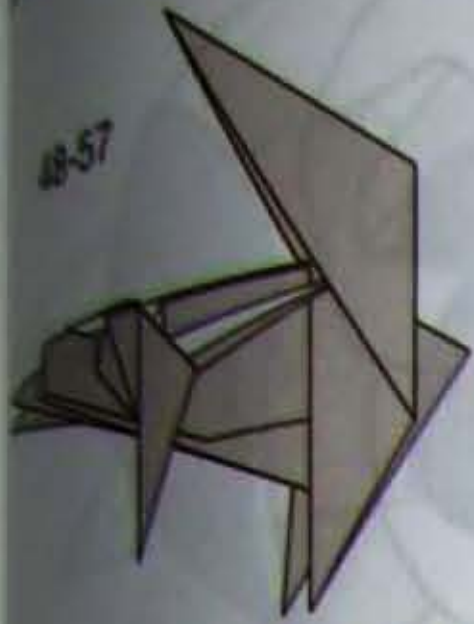

58. Repeat steps 48-57 behind.

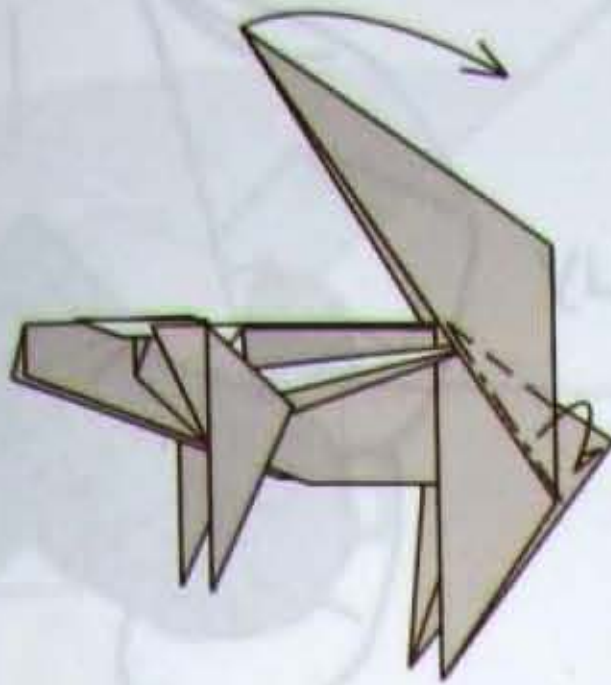

59. Crimp the tail into an upright position.

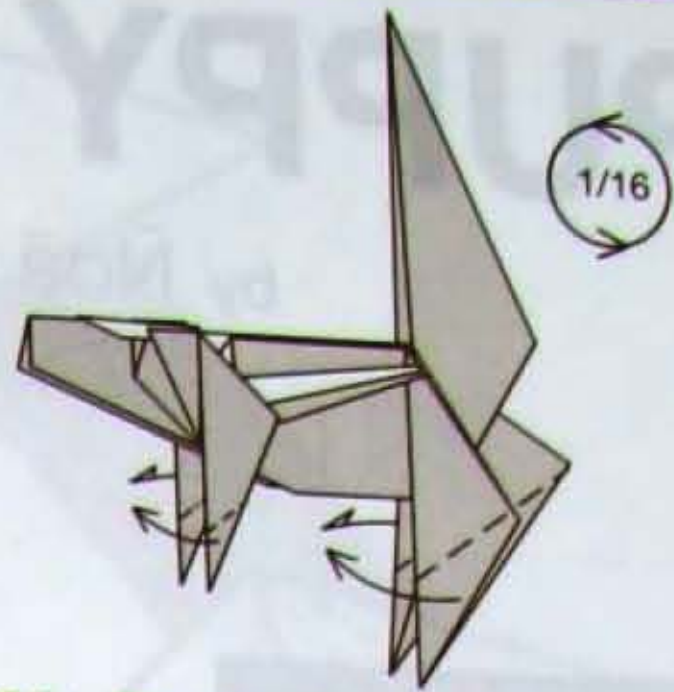

60. Rotate the model slightly, and valley fold the bottom flaps forward, ensuring the model stands evenly.

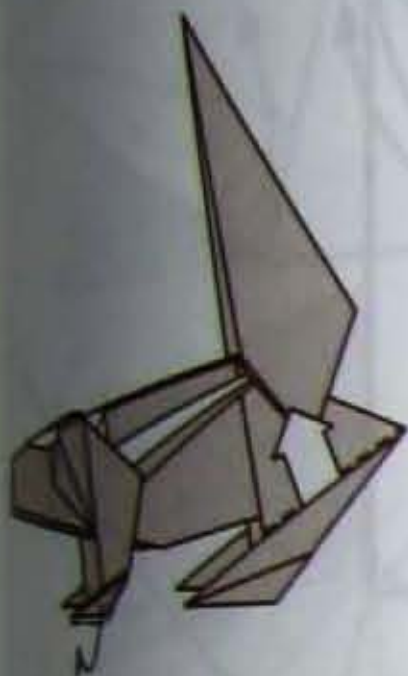

61. Wrap around a layer at the front foot flap and pull out paper at the rear foot flap.

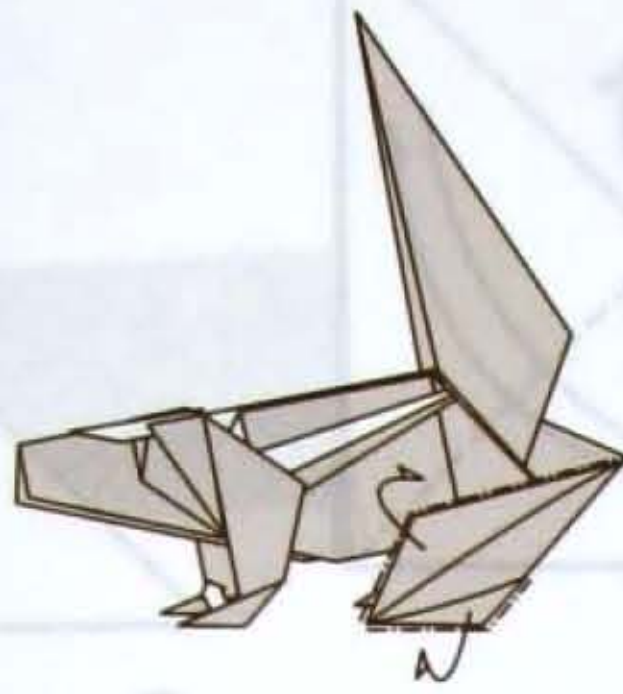

62. Pull out all the layers from the front flap and wrap around two layers at the rear flap.

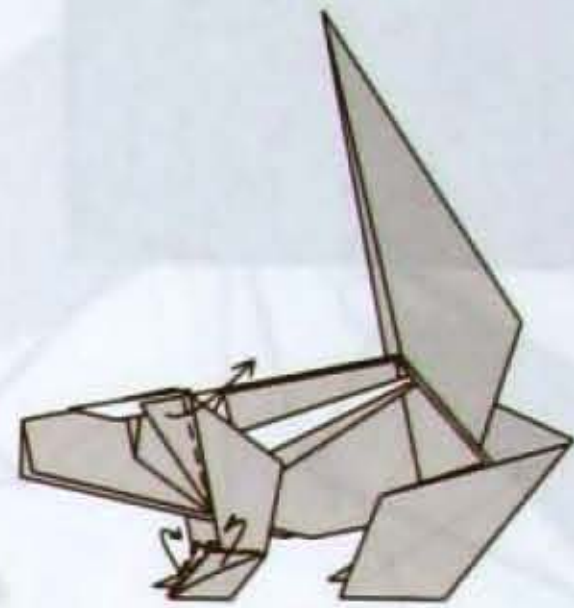

63. Wrap around a layer at each side of the foot flap and swing over the ear flap.

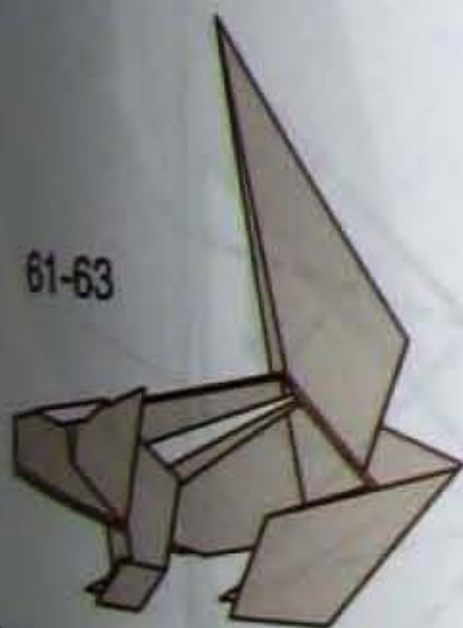

64. Repeat steps 61-63 behind.

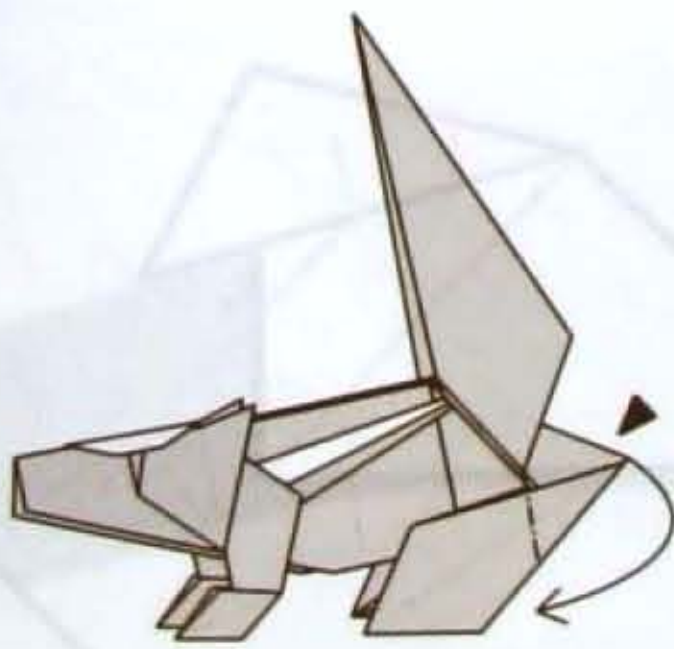

65. Reverse fold the center flap.

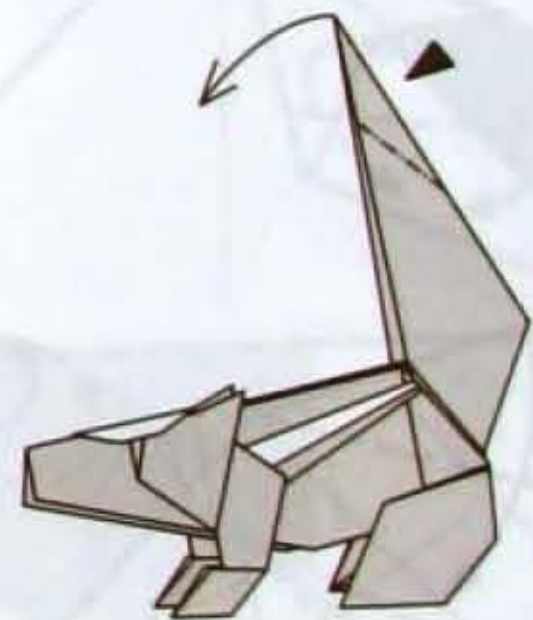

66. Softly reverse fold the tip of the tail flap.

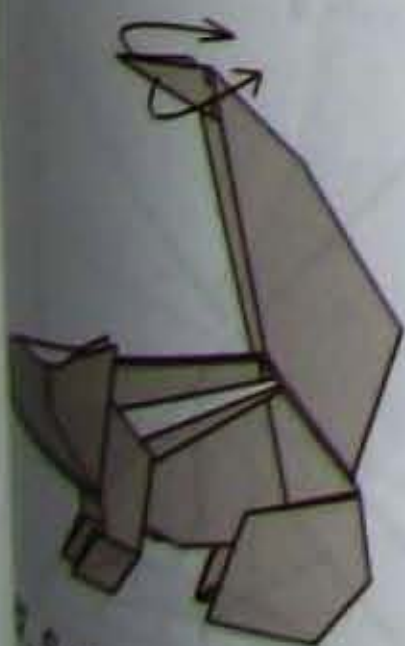

67. Softly wrap around the tip of the flap.

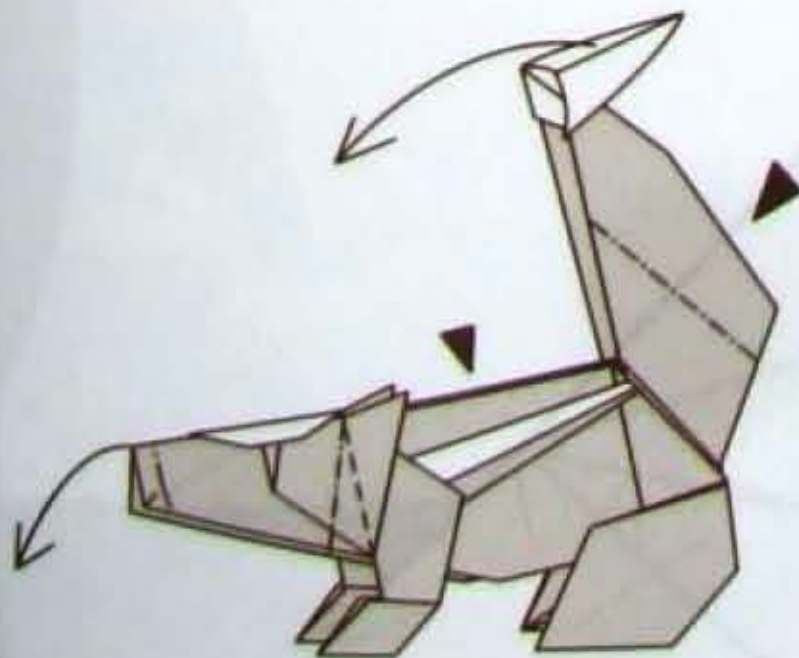

68. Crimp the head down and shape the body and tail to taste.

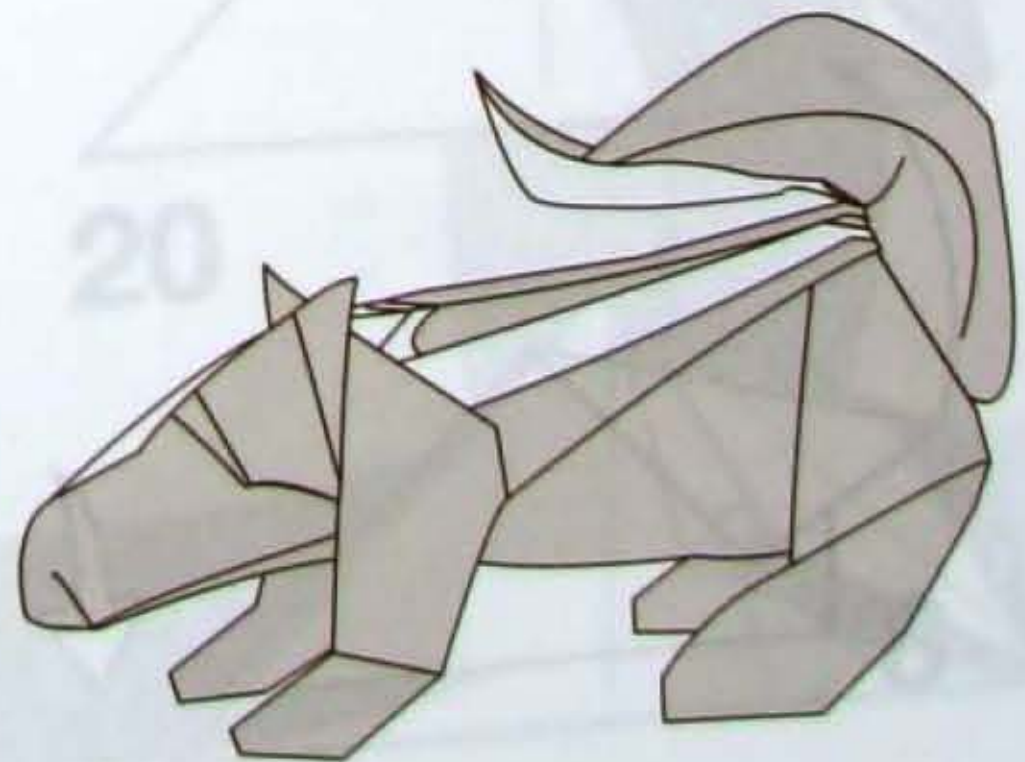

69. Completed Skunk ©1994 Marc Kirschenbaum

PUPPY

by Ñoã Baù Huy

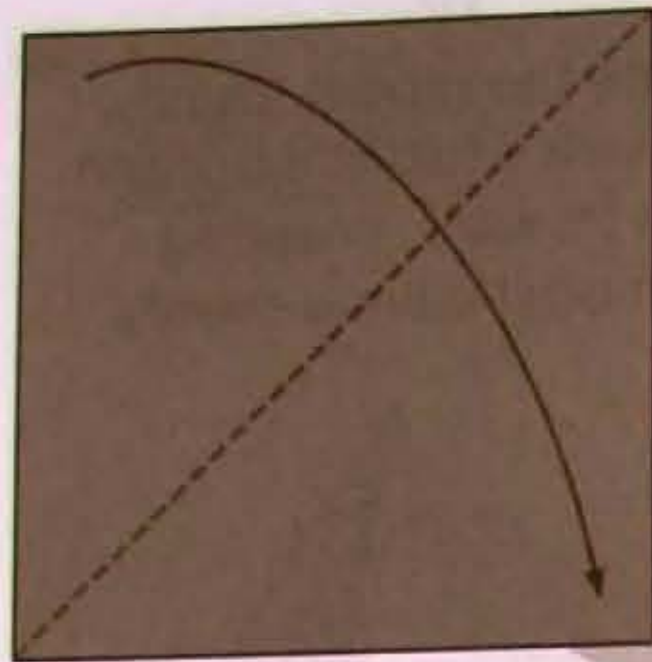

1

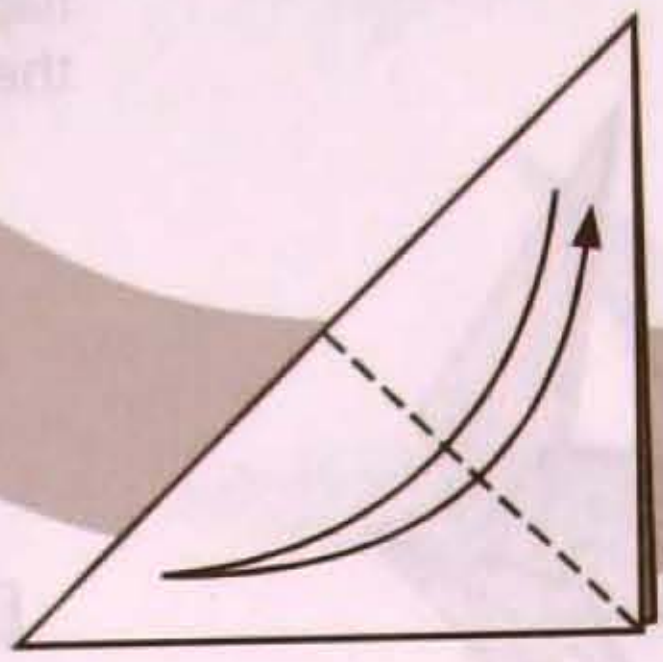

2

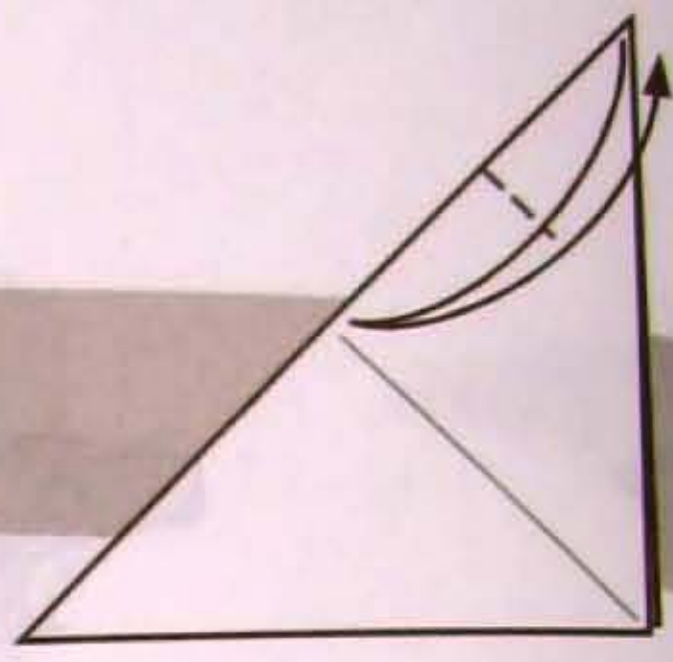

3

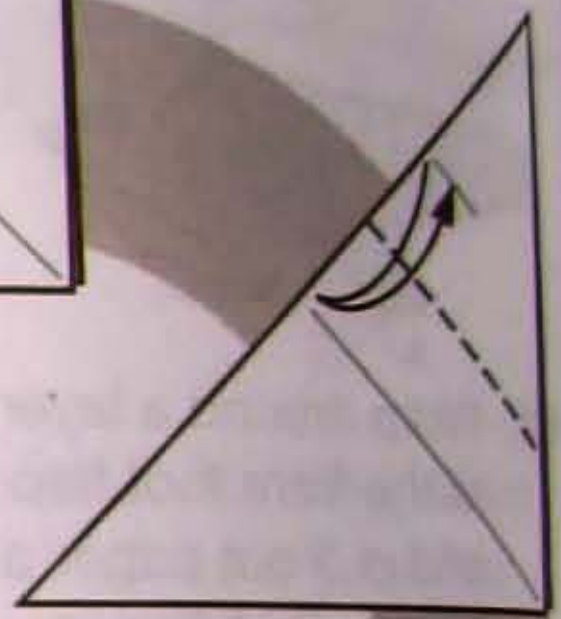

4

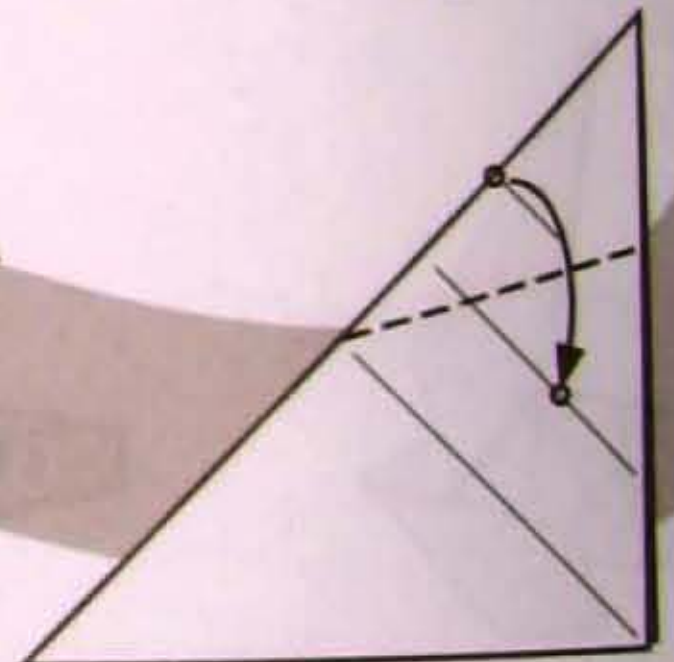
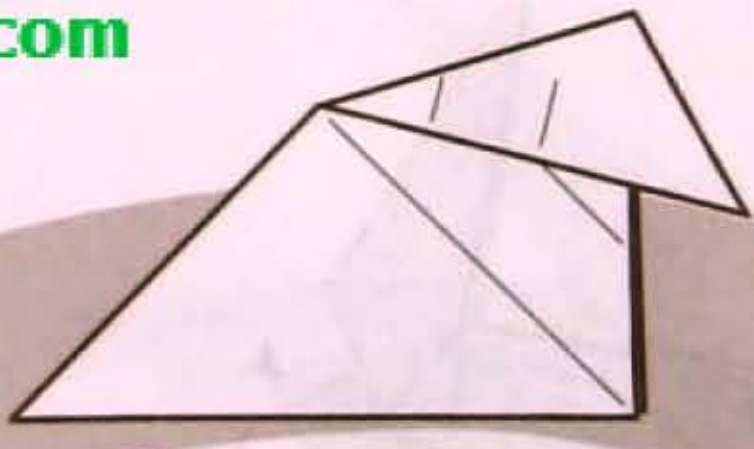

5

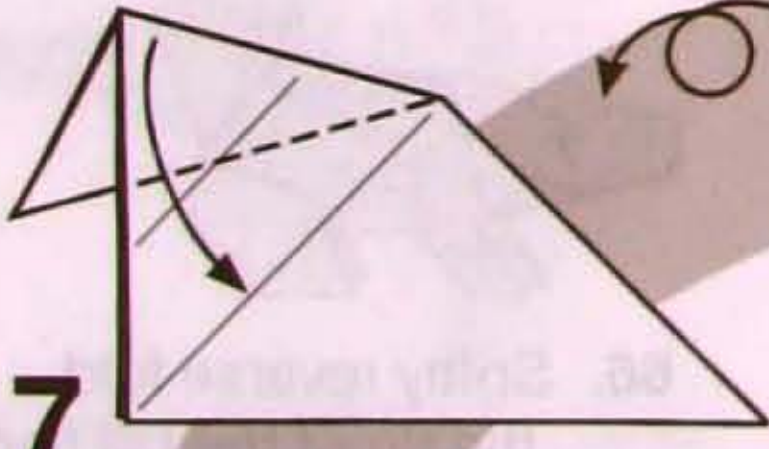

7

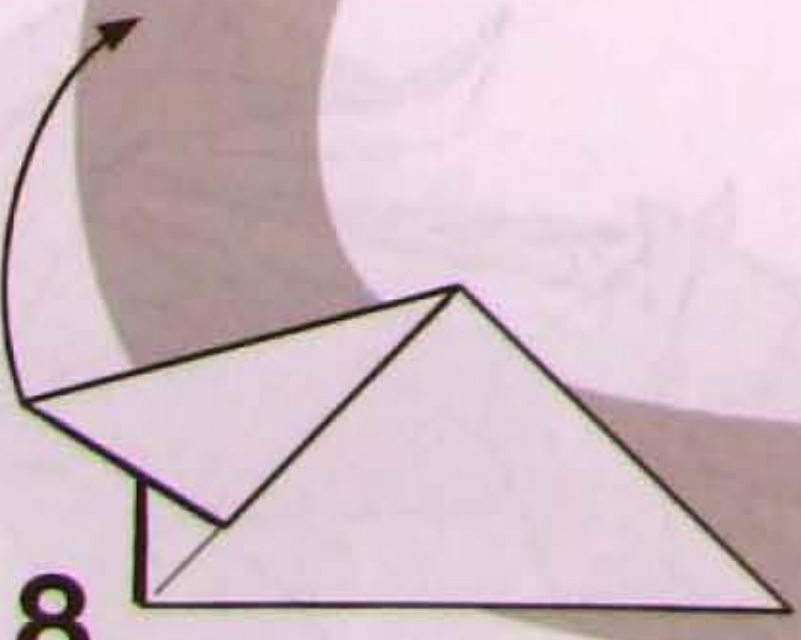

8

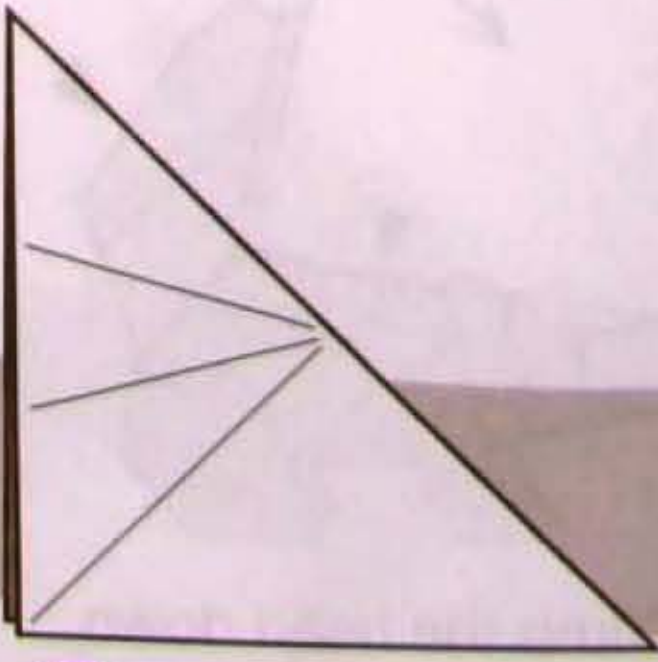

9

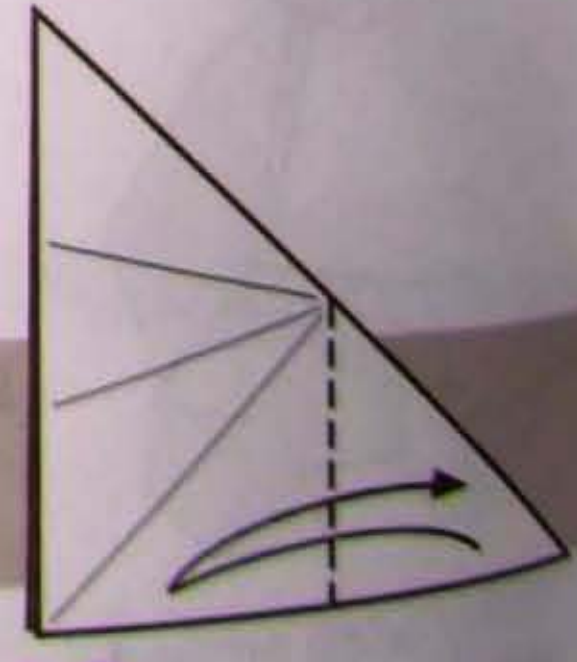

10

Japão Burajirujin

www.japaoburajirujin.blogspot.com

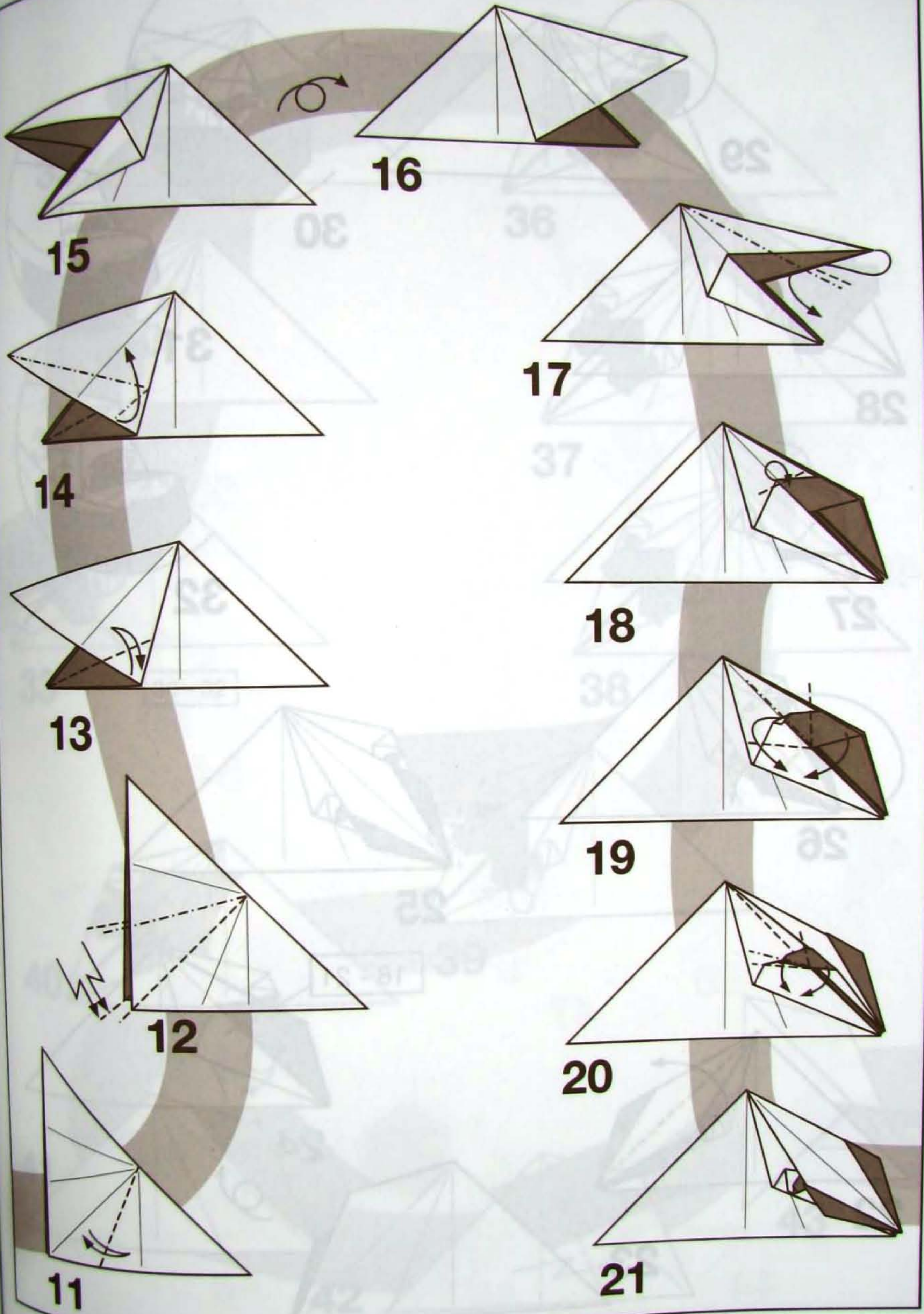

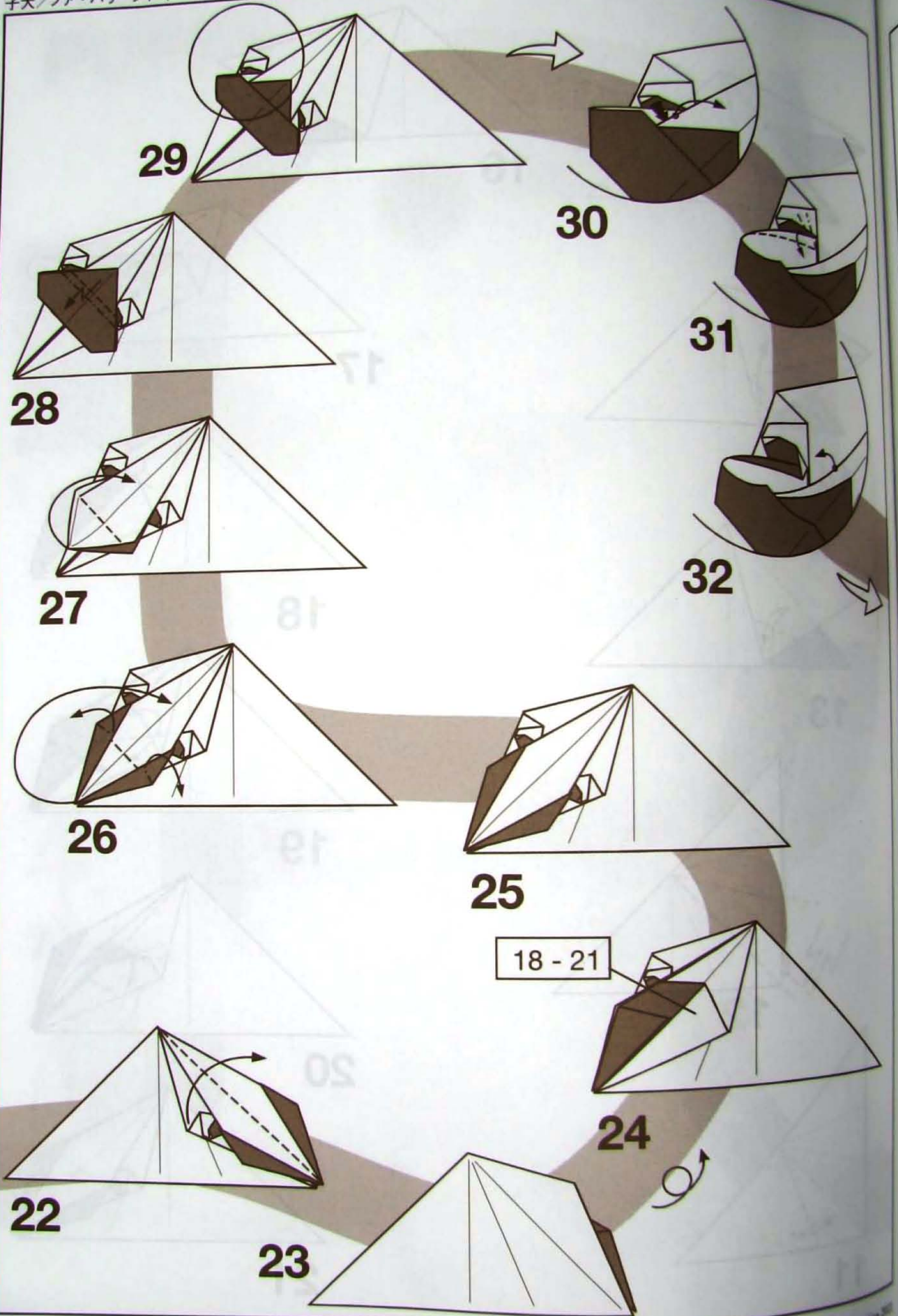

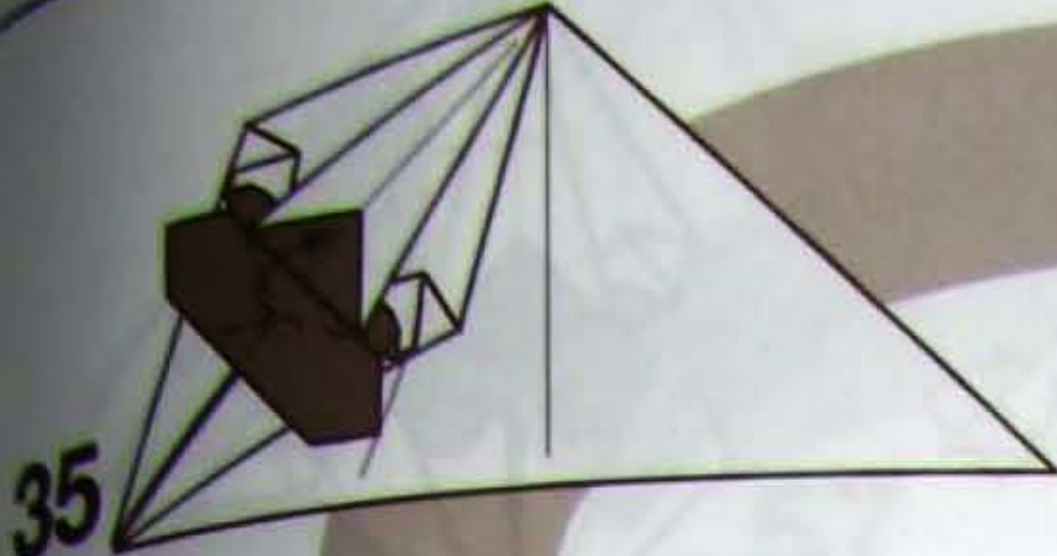

35

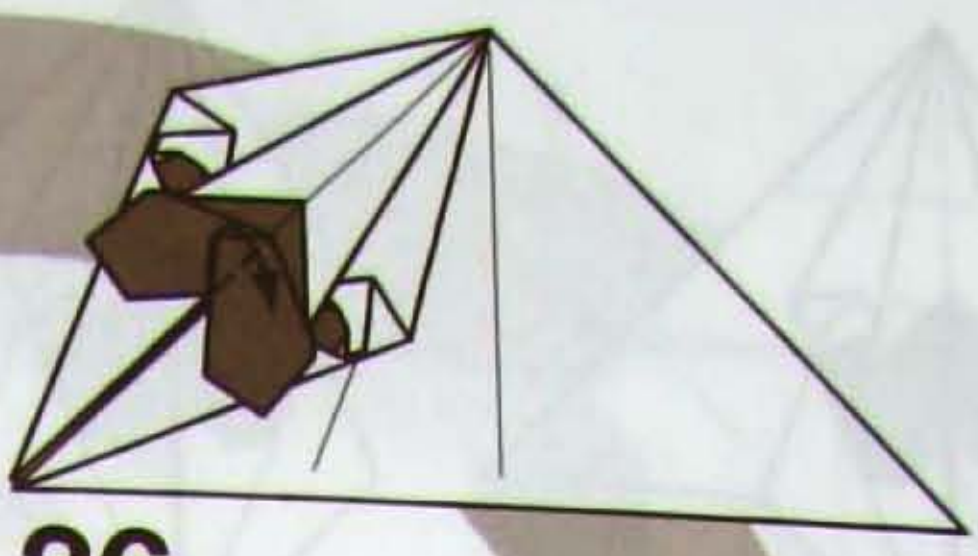

36

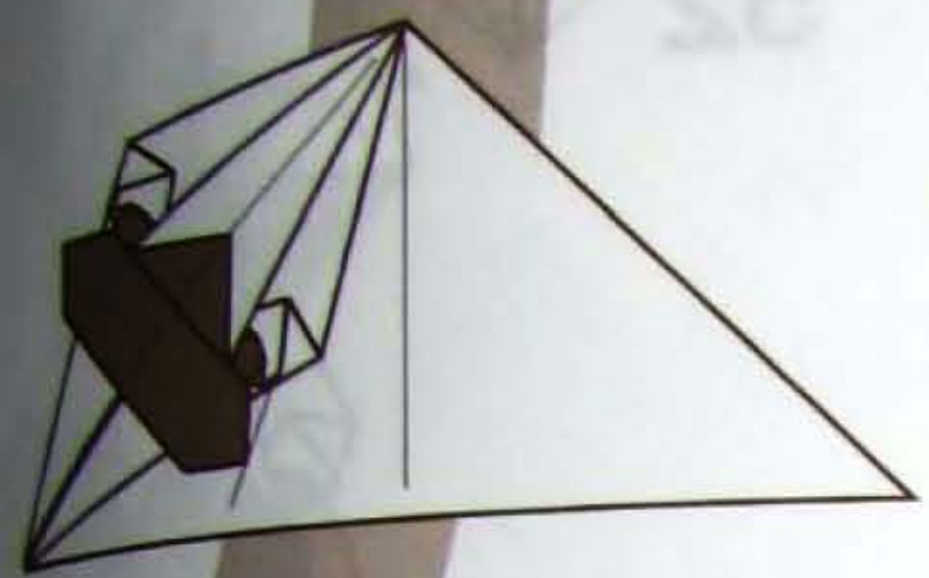

34

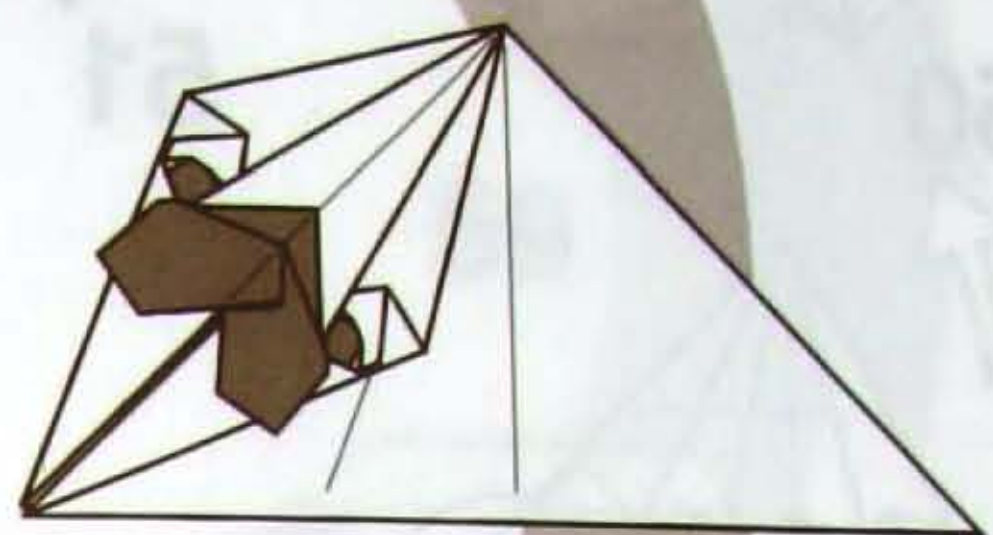

37

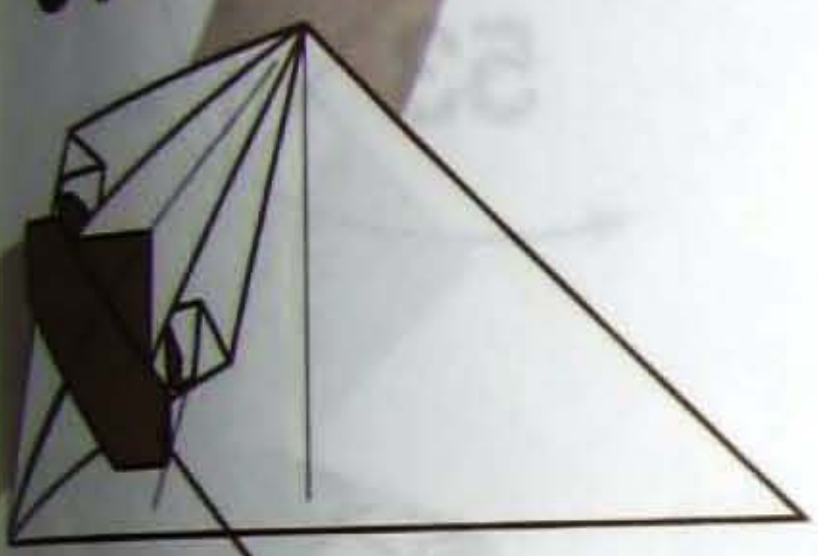

33

30 - 32

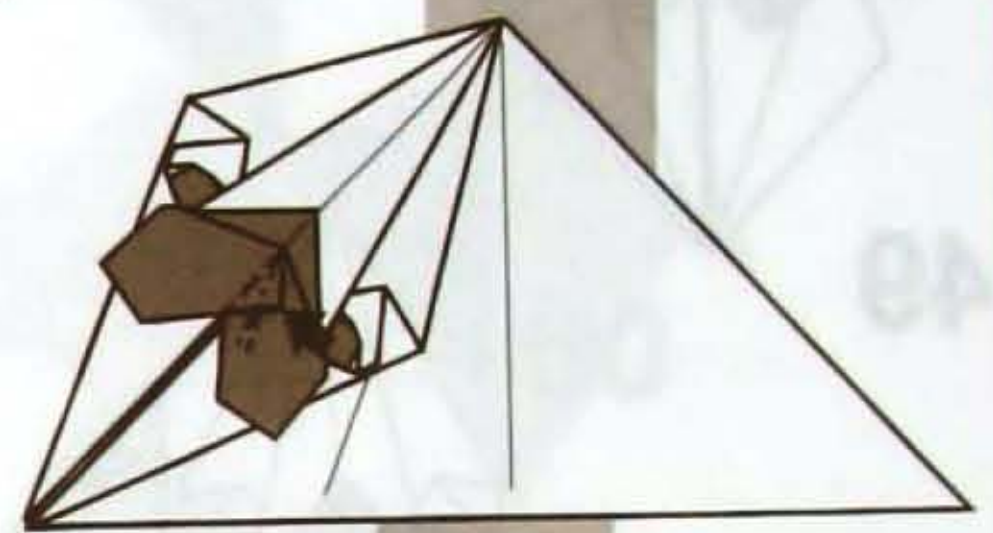

38

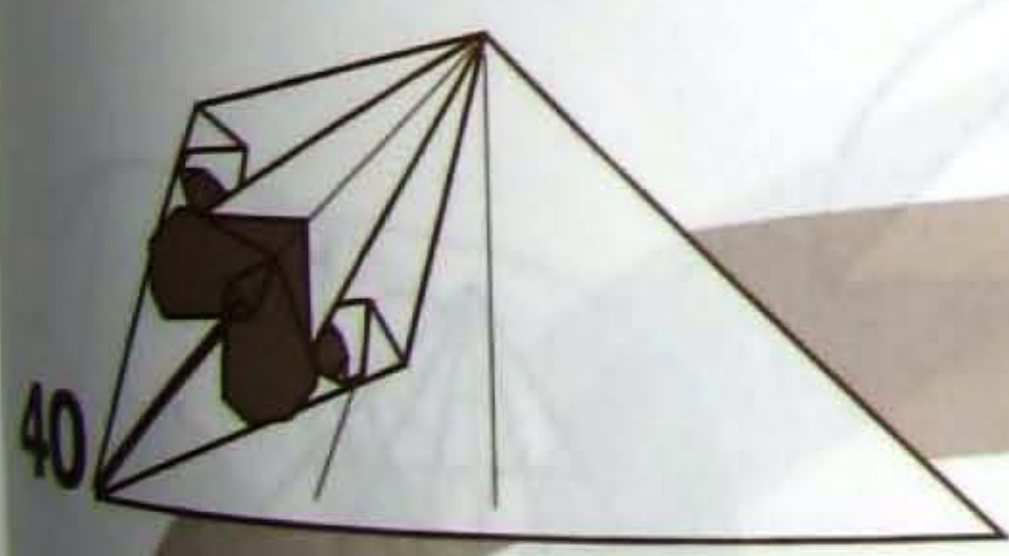

40

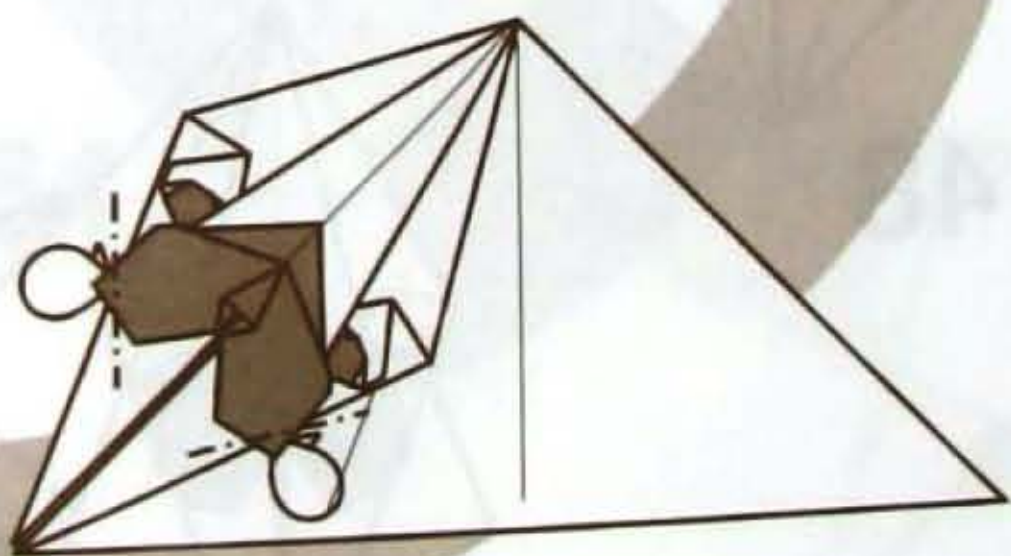

39



41

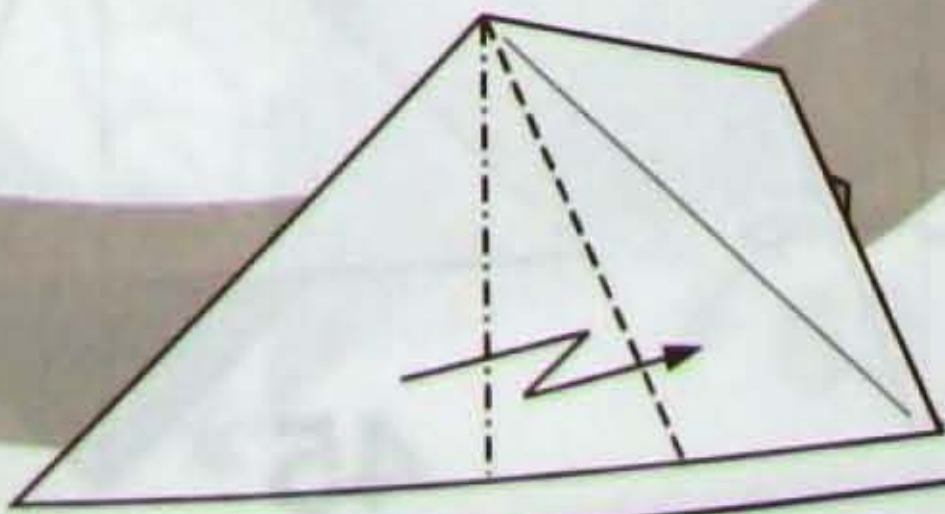

42

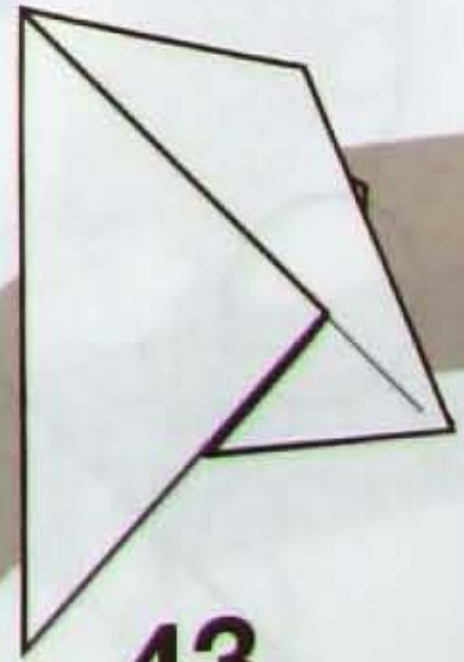

43

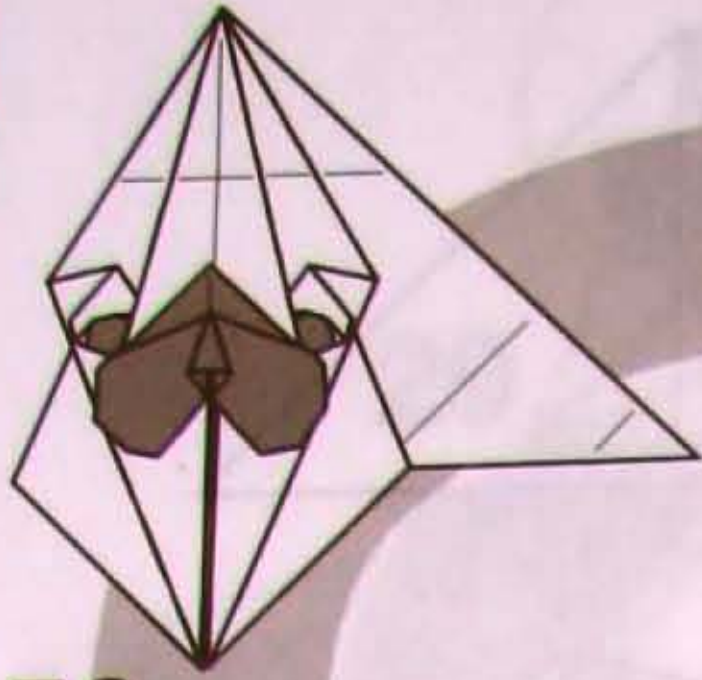

50

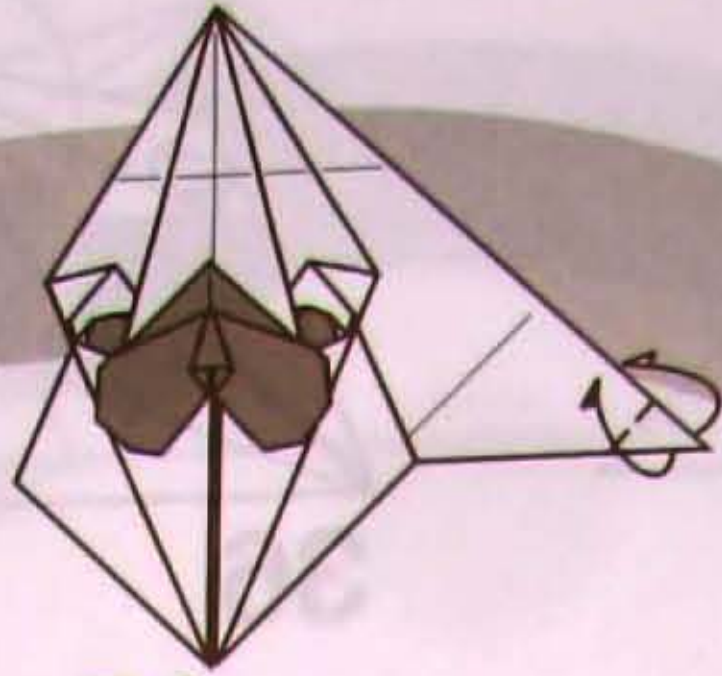

51

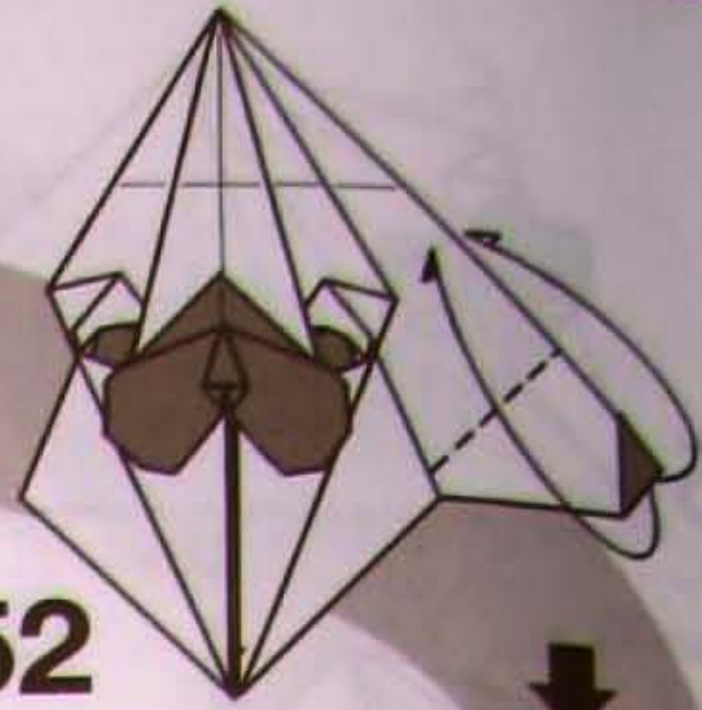

52

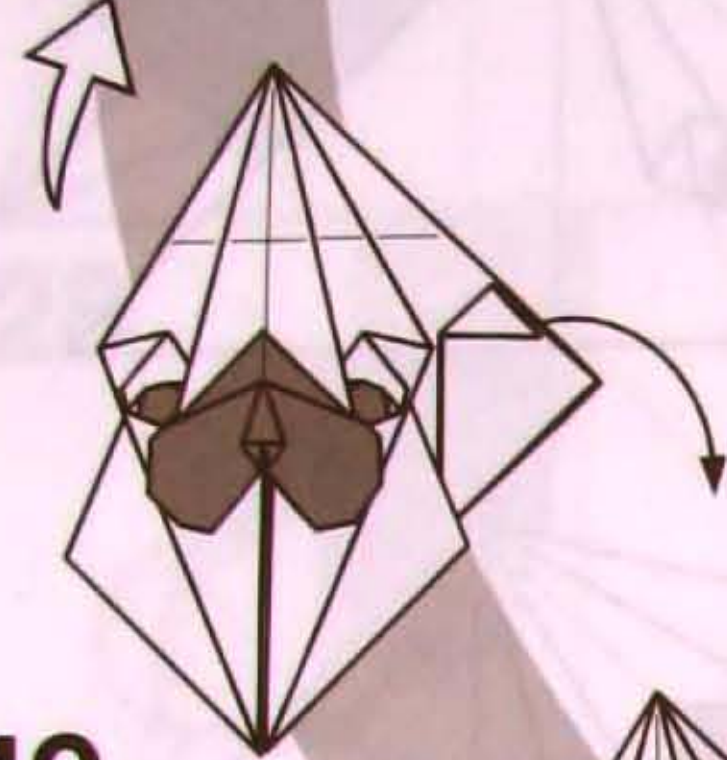

49

Japão Burajirujin

www.japaoburajirujin.blogspot.com



53

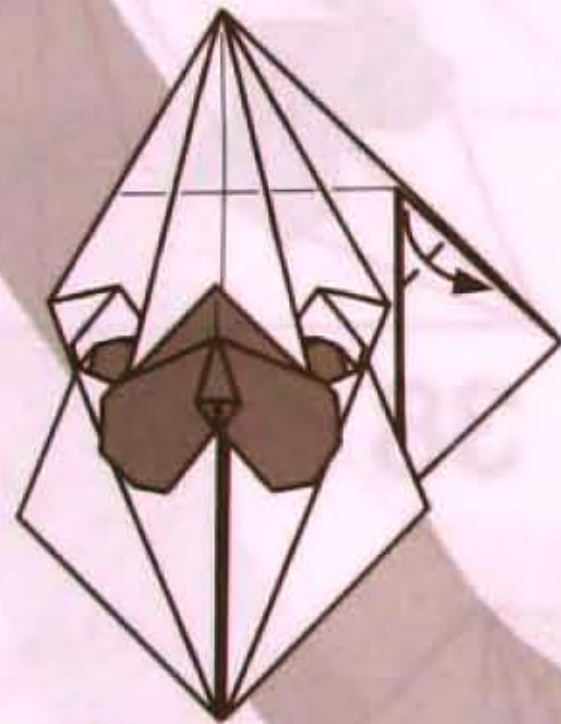

48

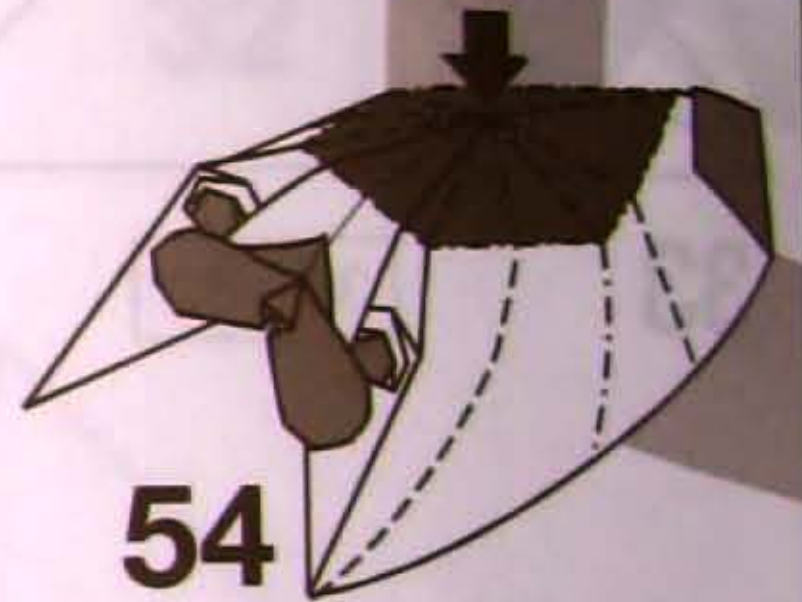

54

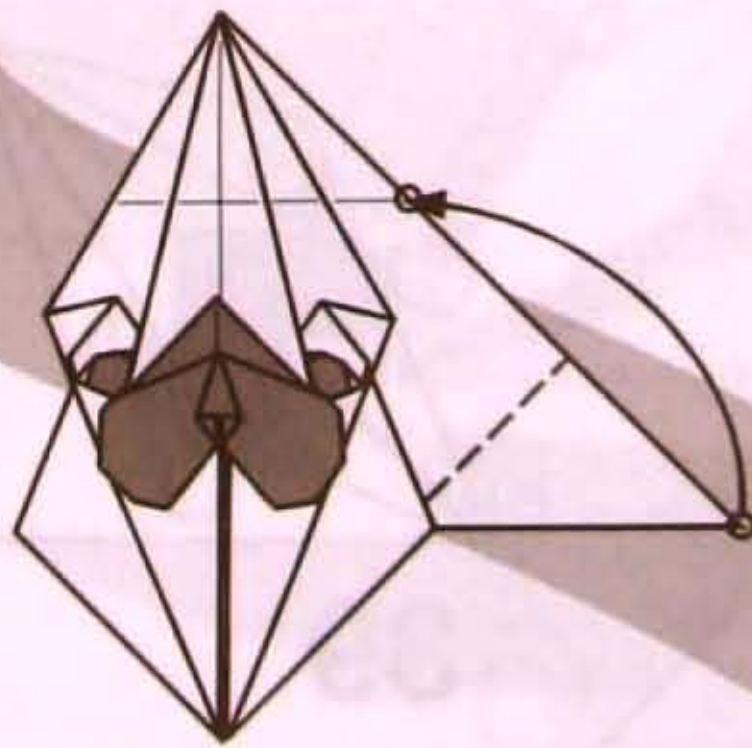

47

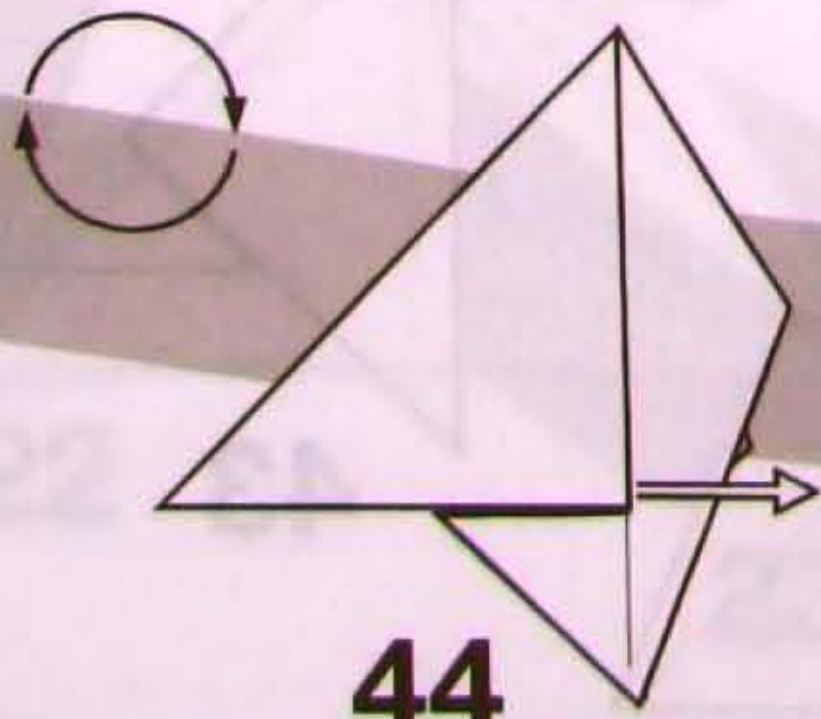

44

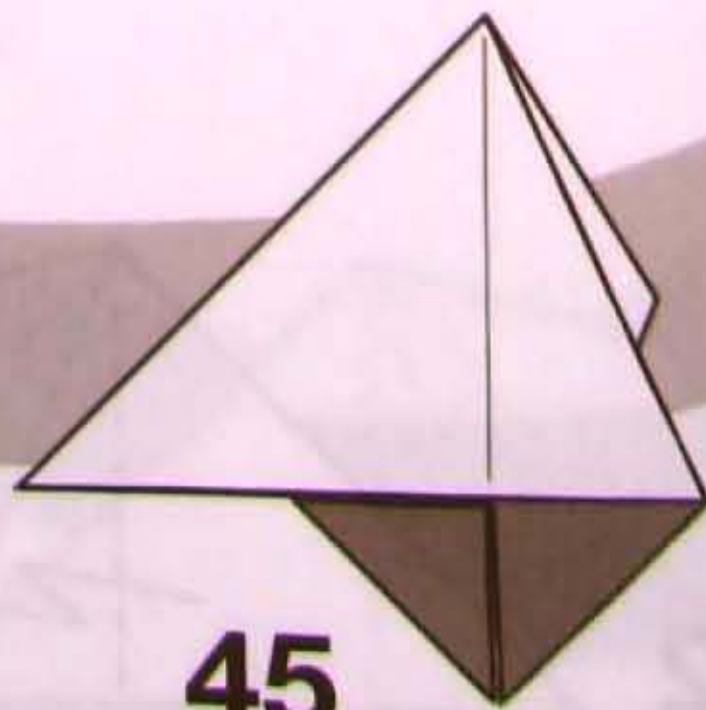

45

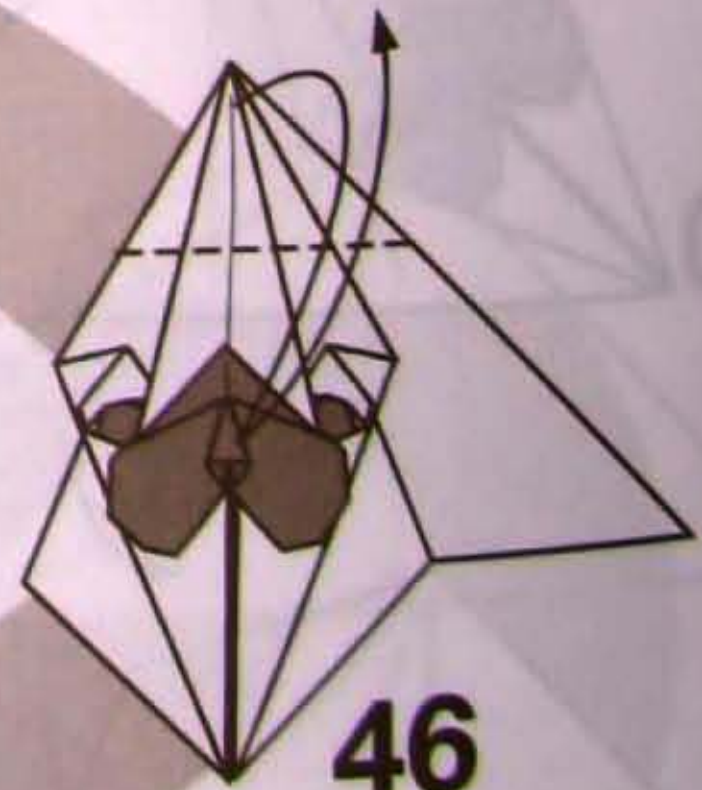

46

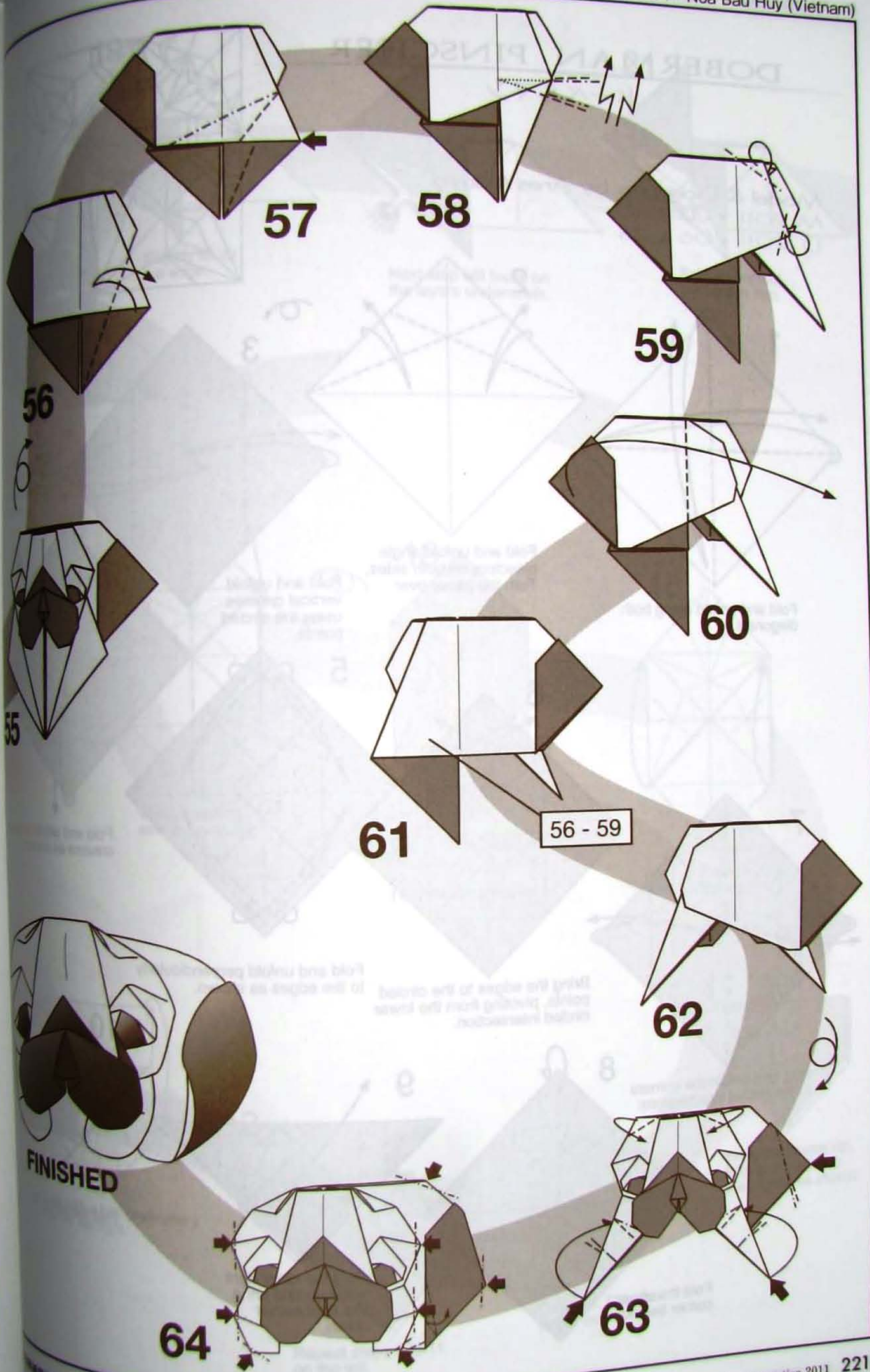

FINISHED

56 - 59

DOBERMAN PINSCHER

ドーベルマン

Model & Diagrams by Ares Alanya

M 2011 • 02 • xx

D 2011 • 06 • 23

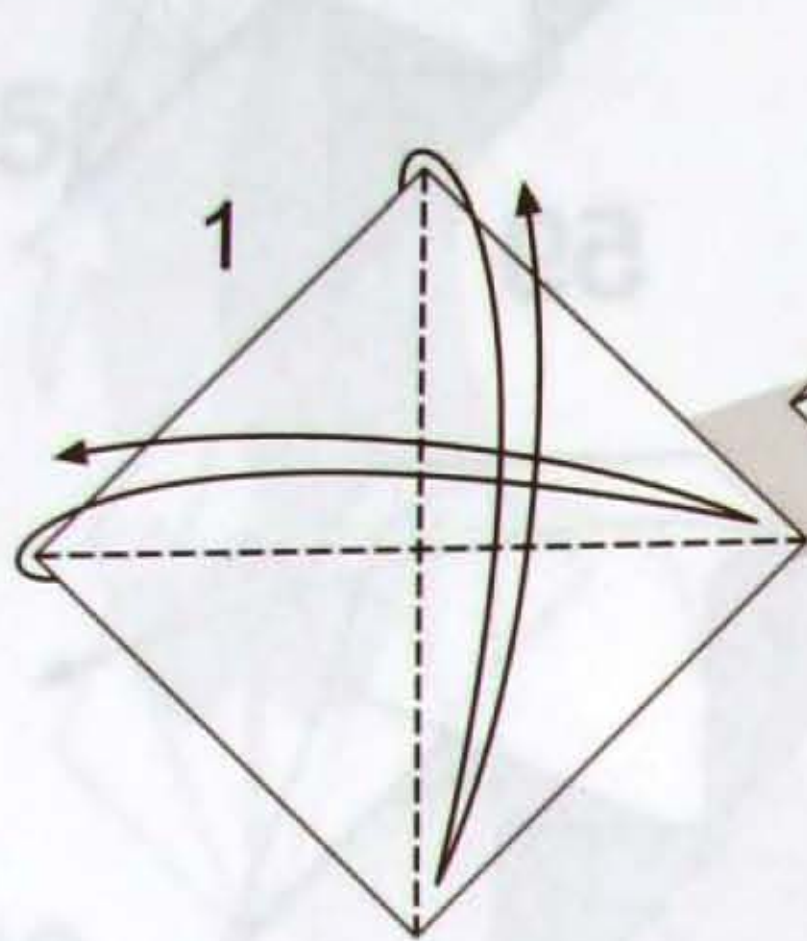
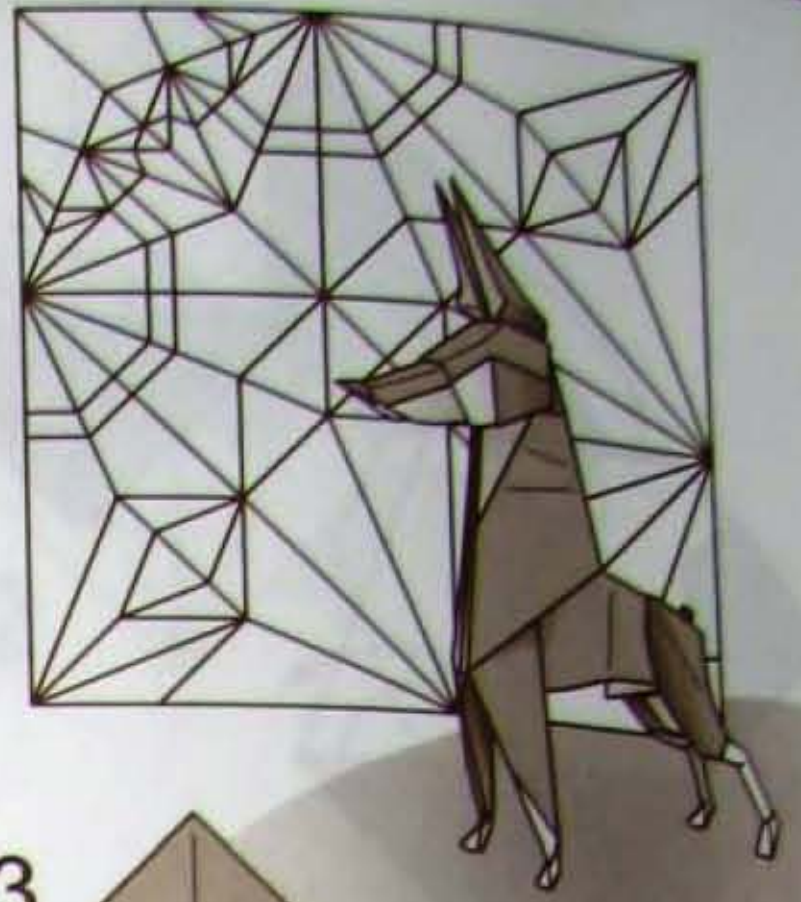

1
Fold and unfold along both diagonals.

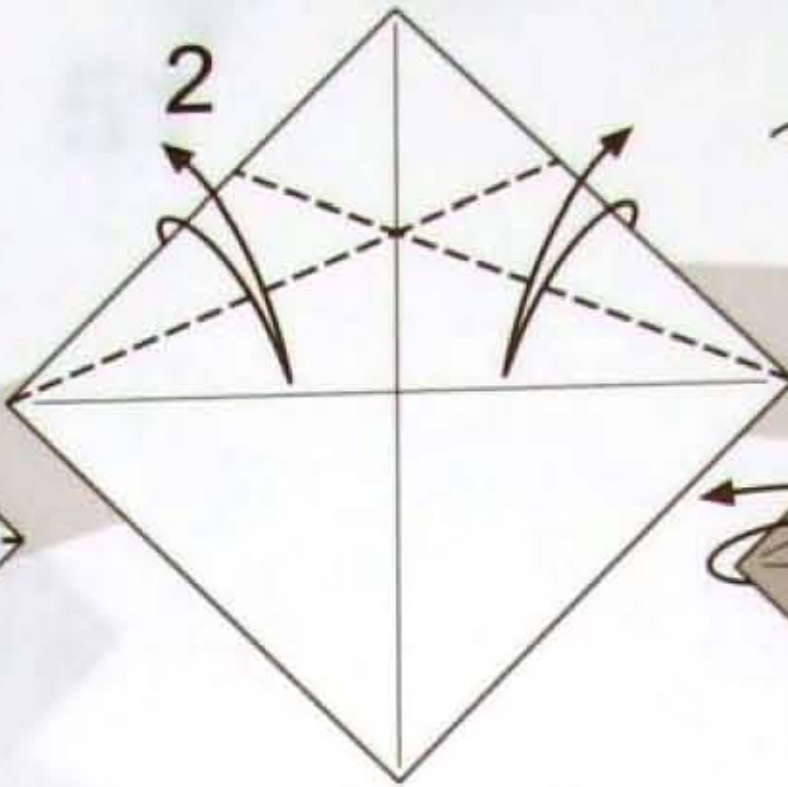

2
Fold and unfold angle bisectors on both sides. Turn the paper over.

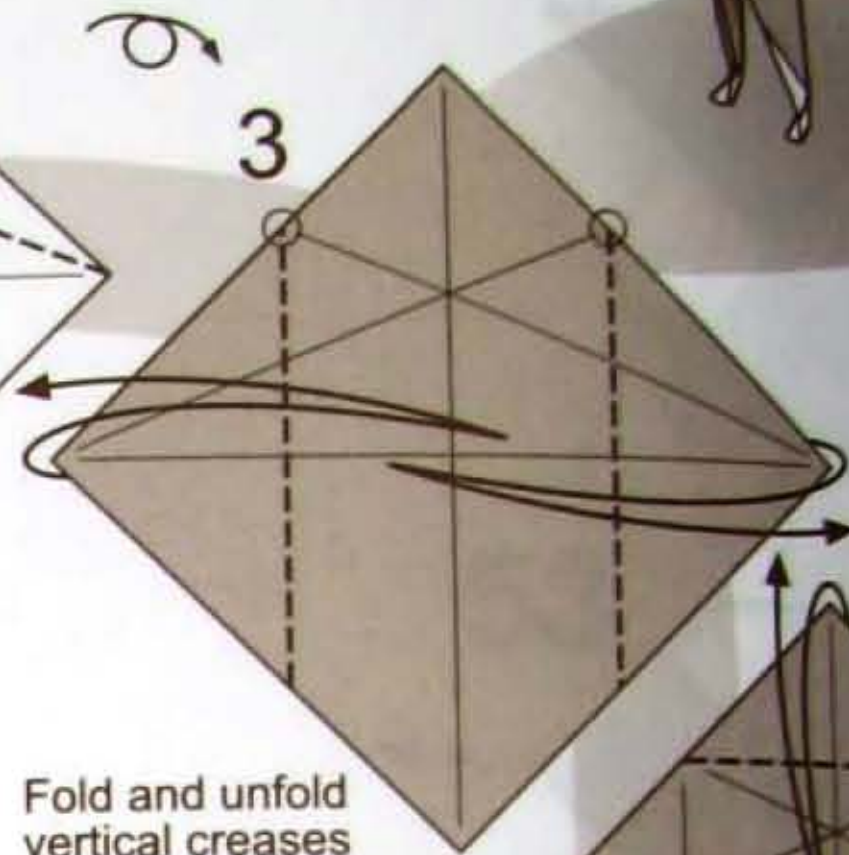

3
Fold and unfold vertical creases using the circled points.

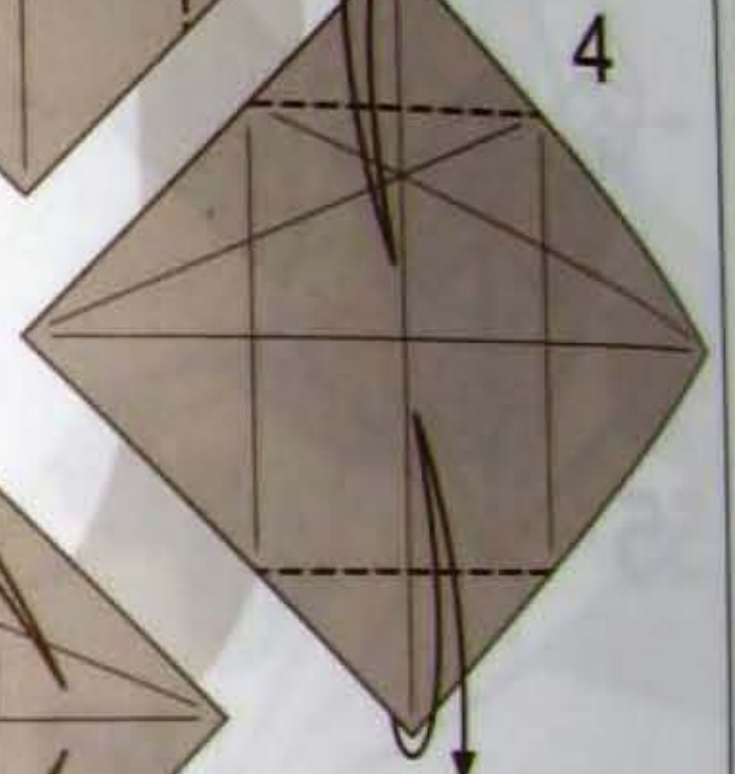

4
Fold and unfold horizontal creases as shown.

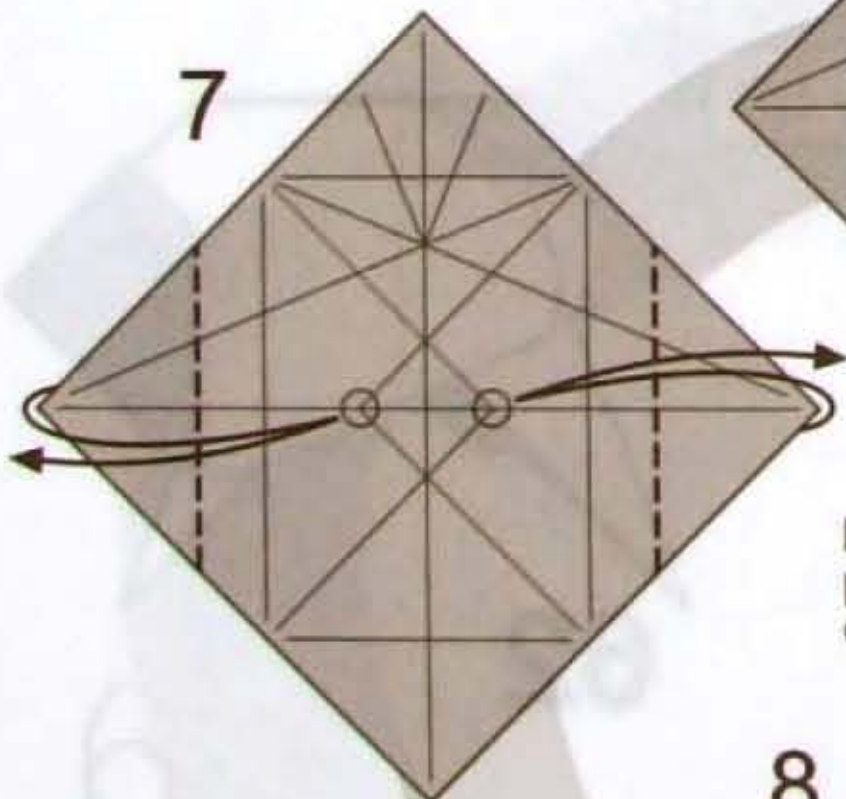

5
Fold and unfold perpendicularly to the edges as shown.

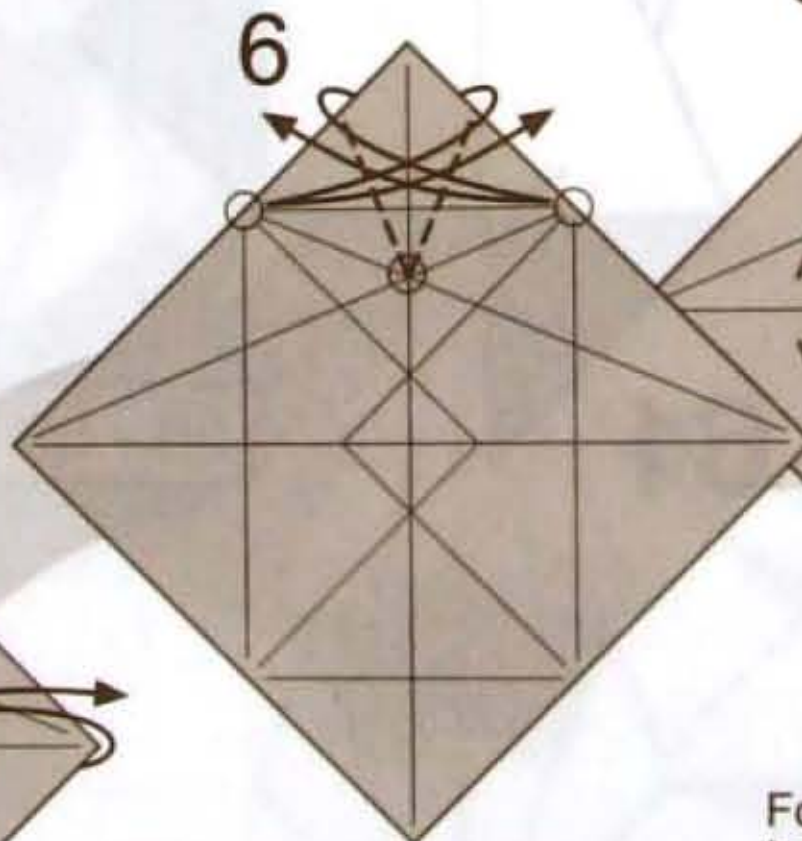

6
Bring the edges to the circled points, pivoting from the lower circled intersection.

7
Fold and unfold the corners to the circled intersections.

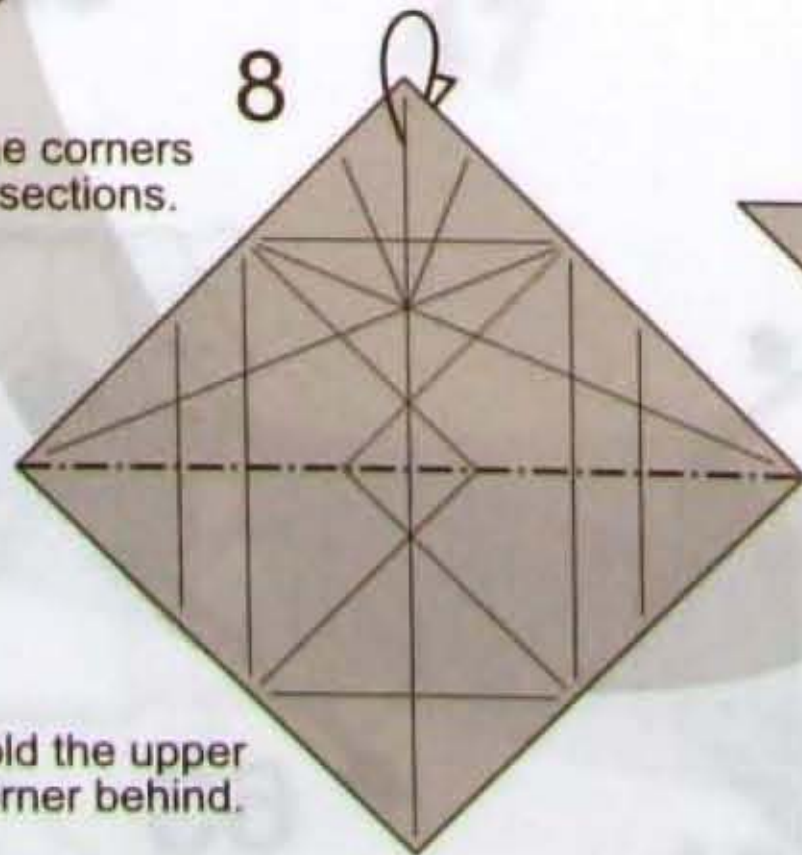

8
Fold the upper corner behind.

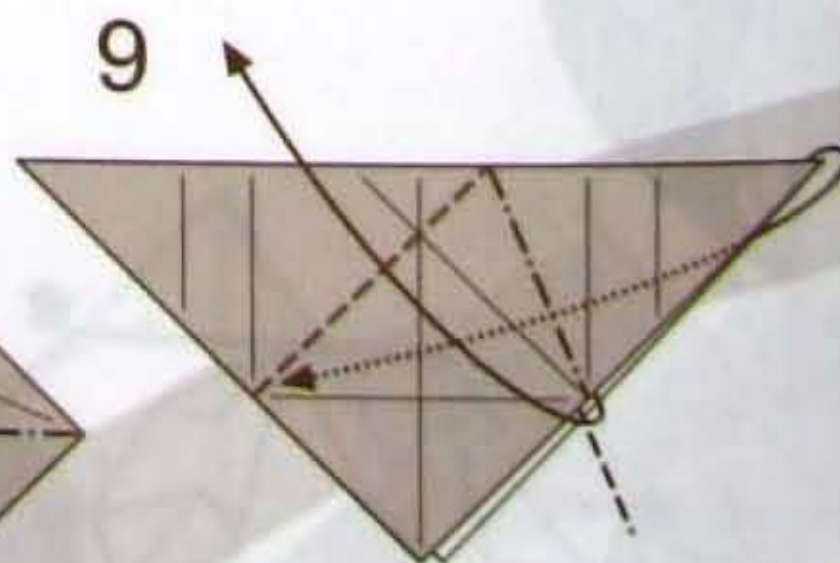

9
Fold the lower right edge up and bring the right corner down.

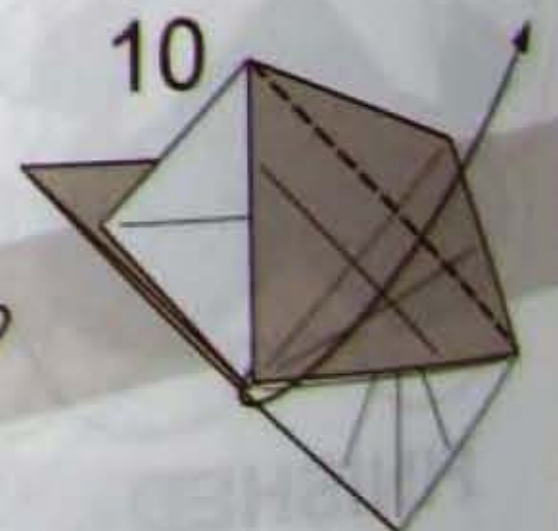

10
Fold the corner up

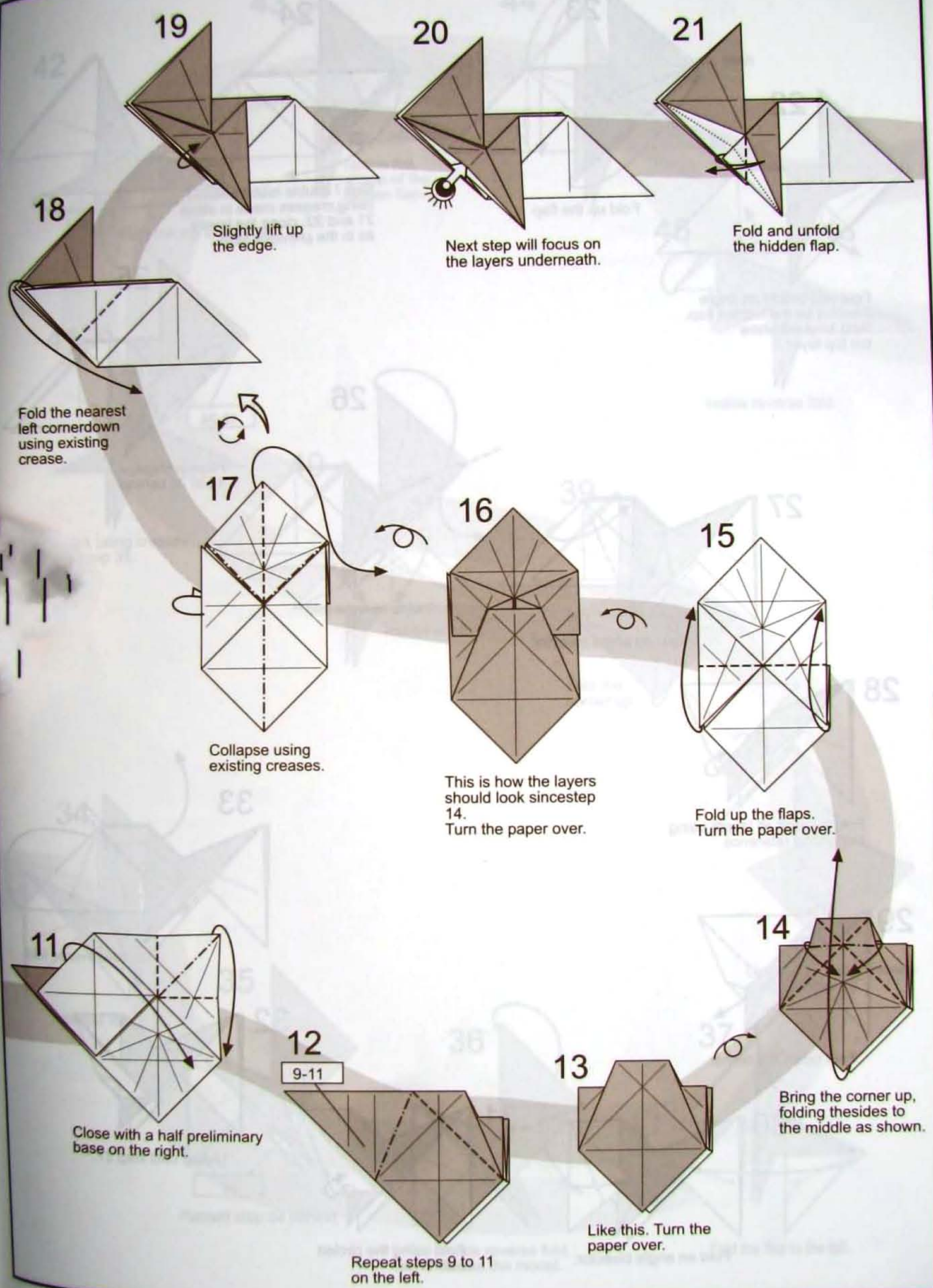

18

Fold the nearest left corner down using existing crease.

19

Slightly lift up the edge.

20

Next step will focus on the layers underneath.

21

Fold and unfold the hidden flap.

17

Collapse using existing creases.

16

This is how the layers should look since step 14. Turn the paper over.

15

Fold up the flaps. Turn the paper over.

11

Close with a half preliminary base on the right.

12

9-11

Repeat steps 9 to 11 on the left.

13

Like this. Turn the paper over.

14

Bring the corner up, folding the sides to the middle as shown.

old horizontal down.

corner up

22
Fold and unfold an angle bisector on the hidden flap. Next step will show the top layer.

23
Fold up the flap

24
Sink / double rabbit ear fold using creases made in steps 21 and 22, close the layers as in the previous step.

25
Repeat steps 18 to 24 behind.

26
Inside reverse fold.

27
Fold an angle bisector.

28
Fold through all layers using the circled reference.

29
Fold down the corner.

30
Fold an angle bisector.

31
Fold using the circled reference.

32
Unfold until step 27.

33
Inside reverse fold.

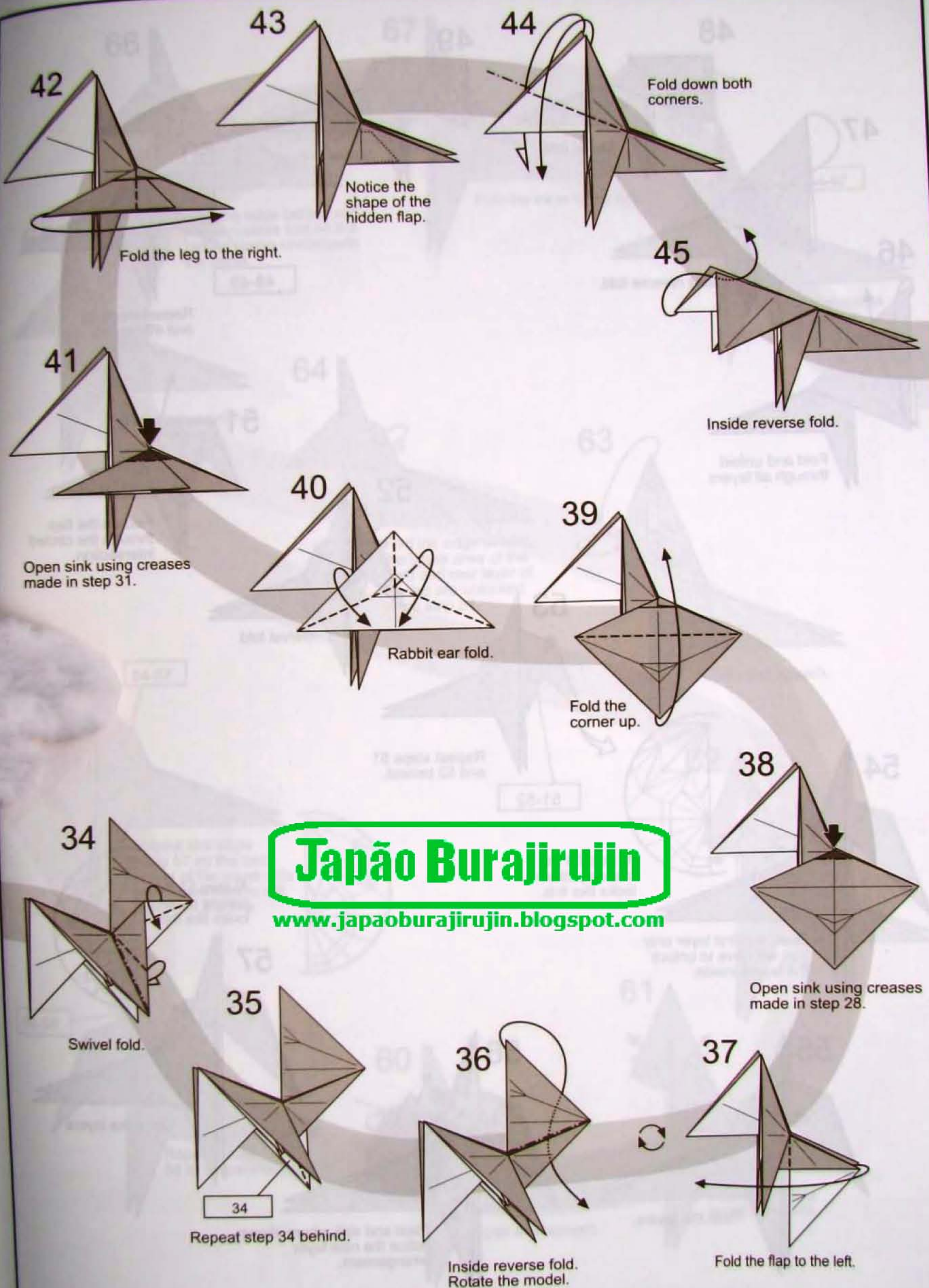

Japão Burajirujin

www.japaoburajirujin.blogspot.com

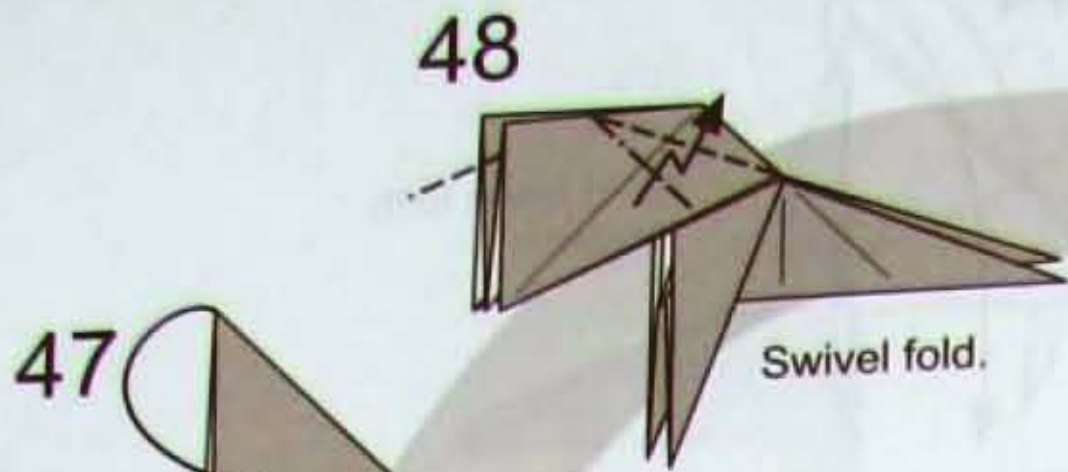

47

Swivel fold.

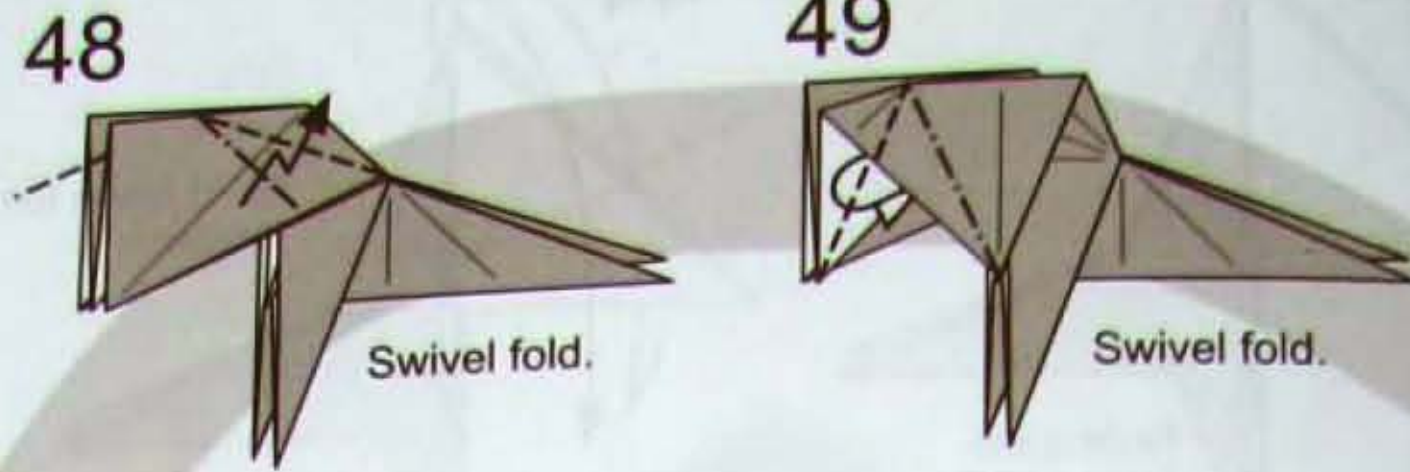

48

Swivel fold.

49

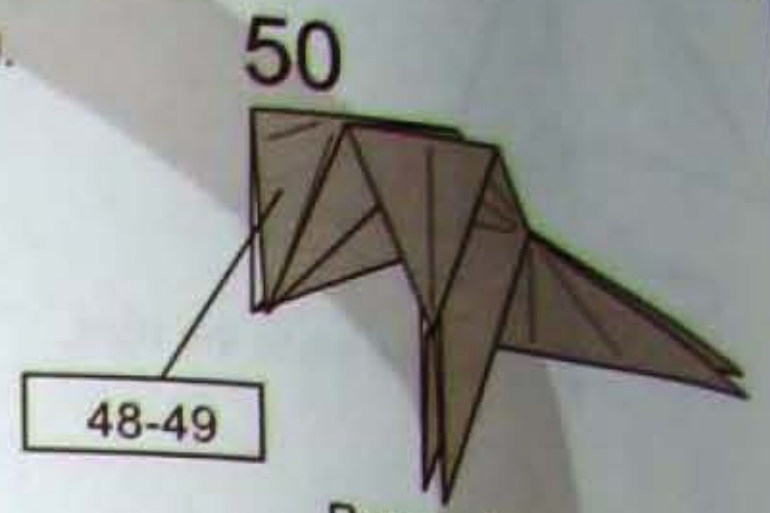

50

48-49

Repeat steps 48 and 49 behind.

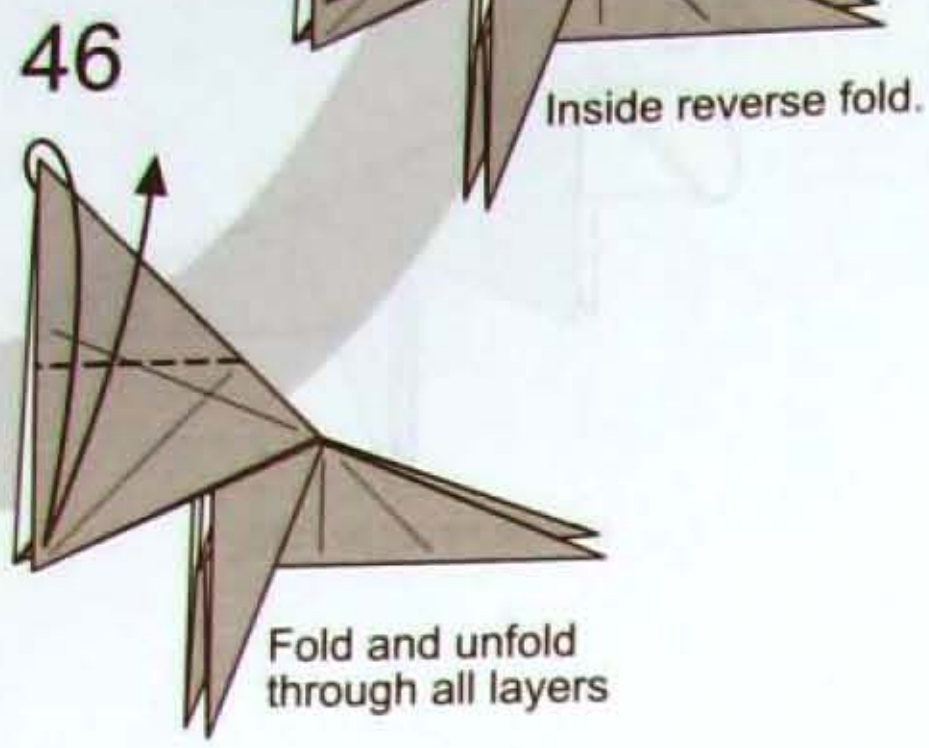

46

Fold and unfold through all layers

Inside reverse fold.

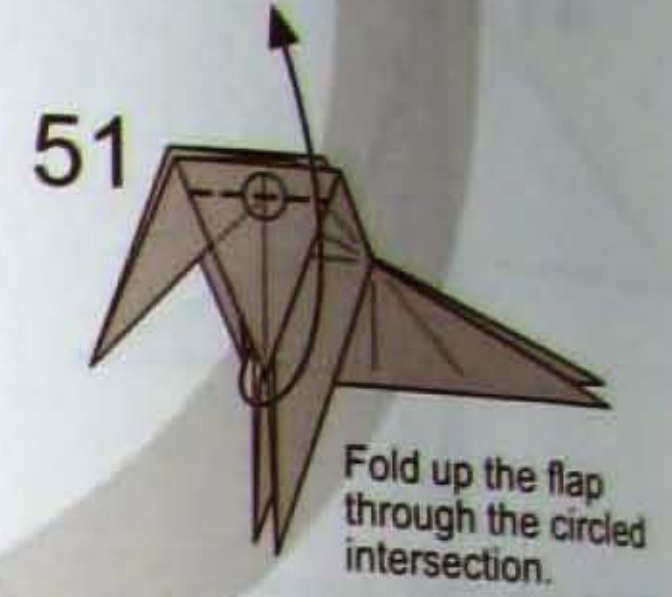

51

Fold up the flap through the circled intersection.

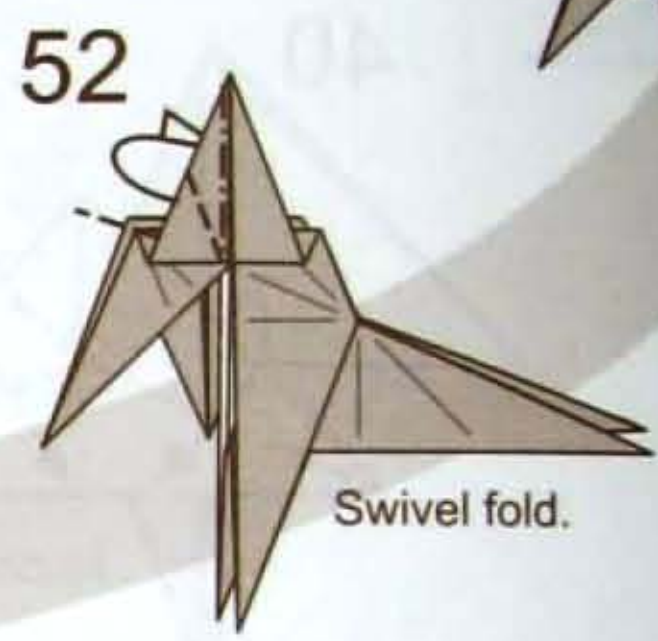

52

Swivel fold.

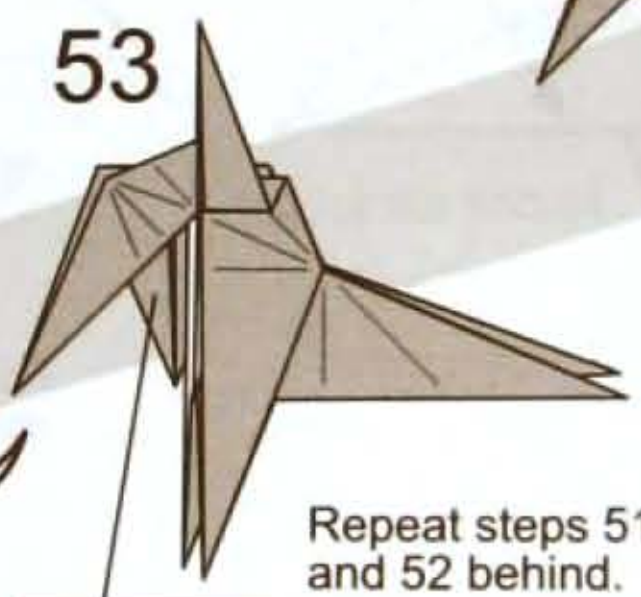

53

Repeat steps 51 and 52 behind.

51-52

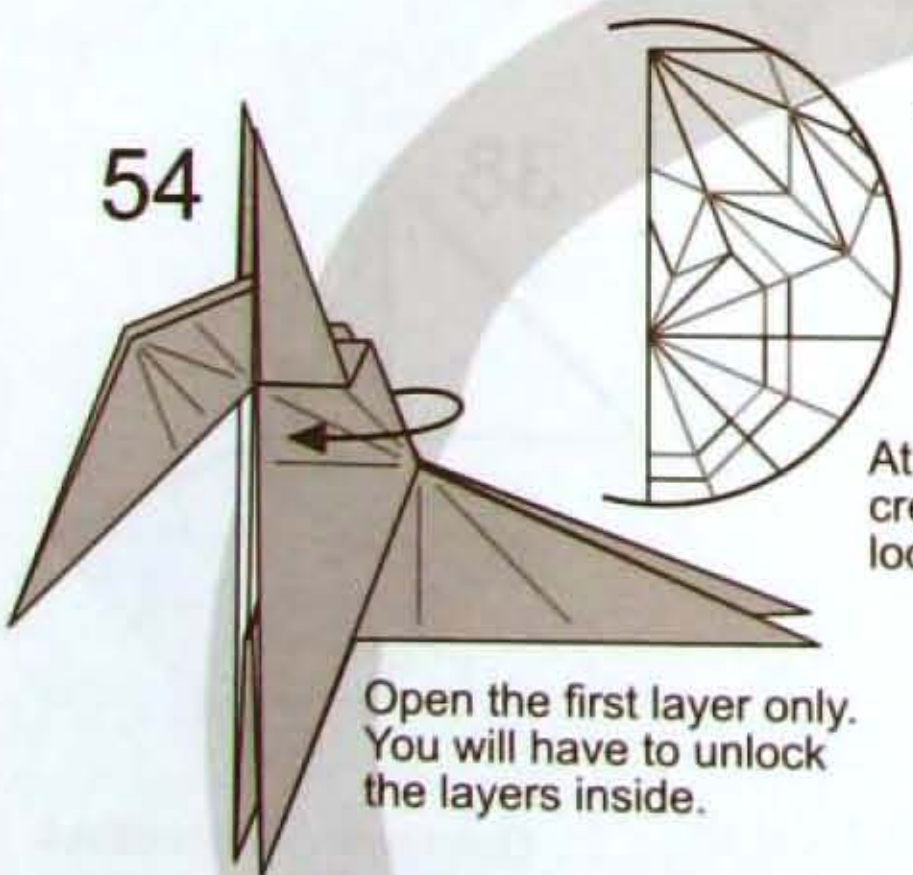

54

At step 54 the crease pattern looks like this.

Open the first layer only. You will have to unlock the layers inside.

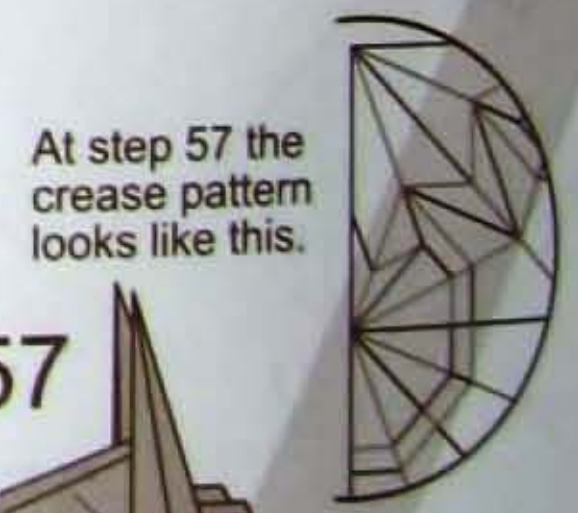

At step 57 the crease pattern looks like this.

57

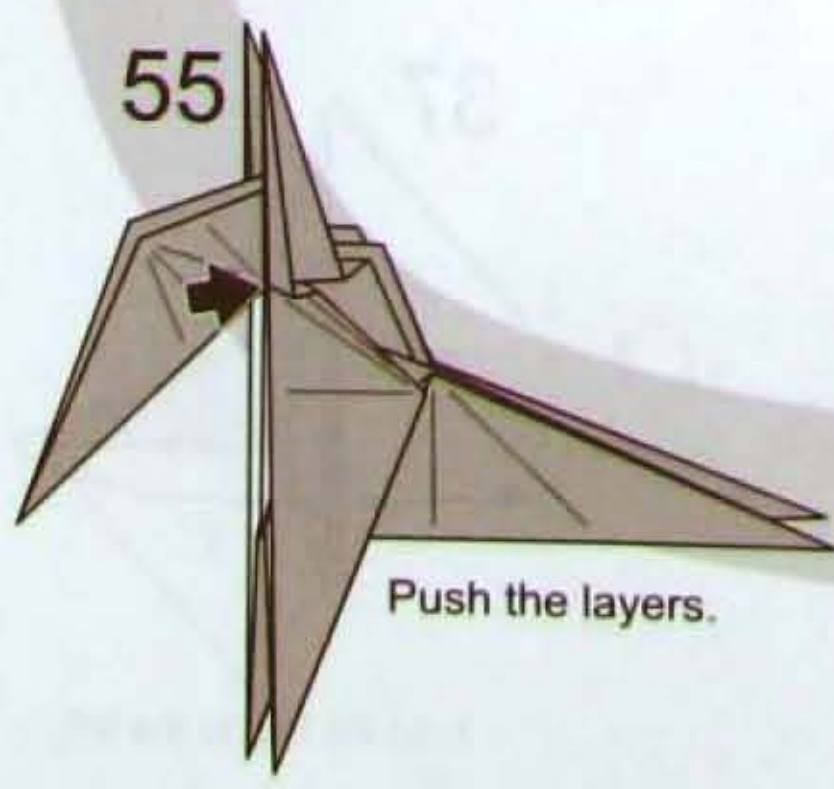

55

Push the layers.

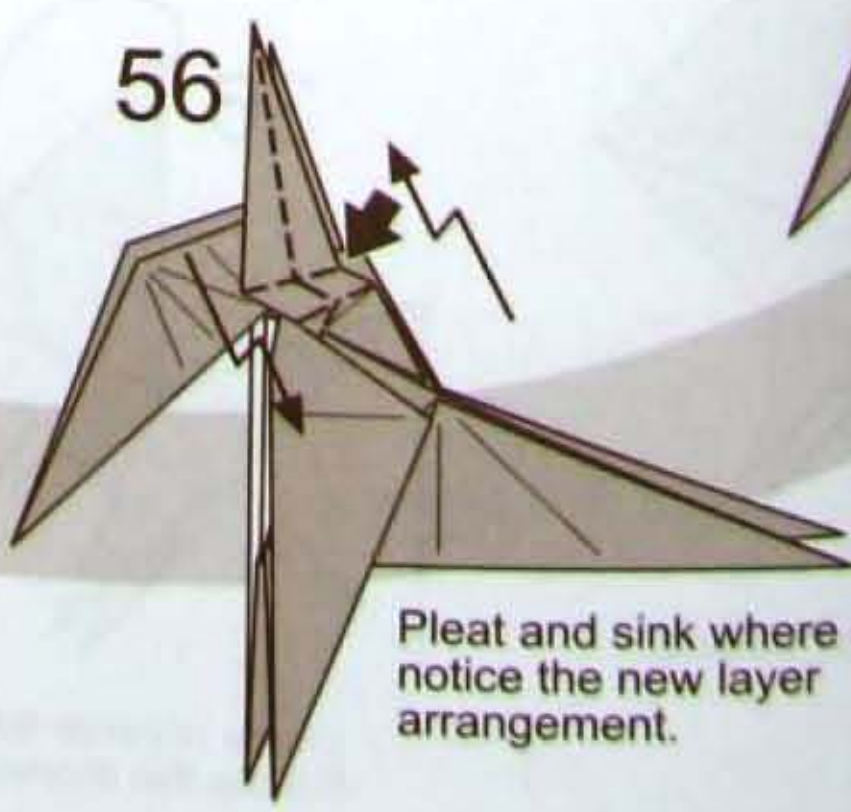

56

Pleat and sink where shown, notice the new layer arrangement.

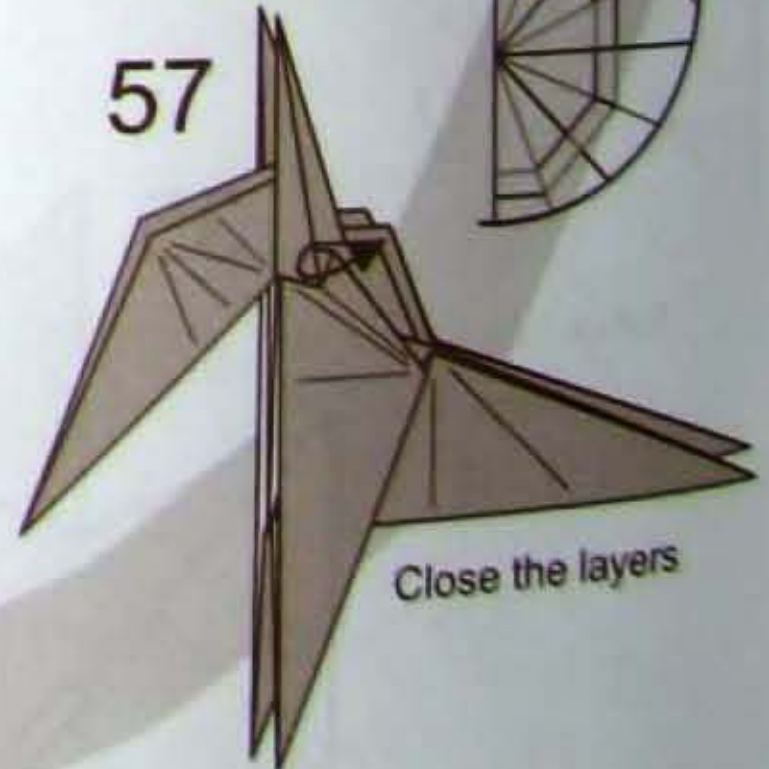

Close the layers

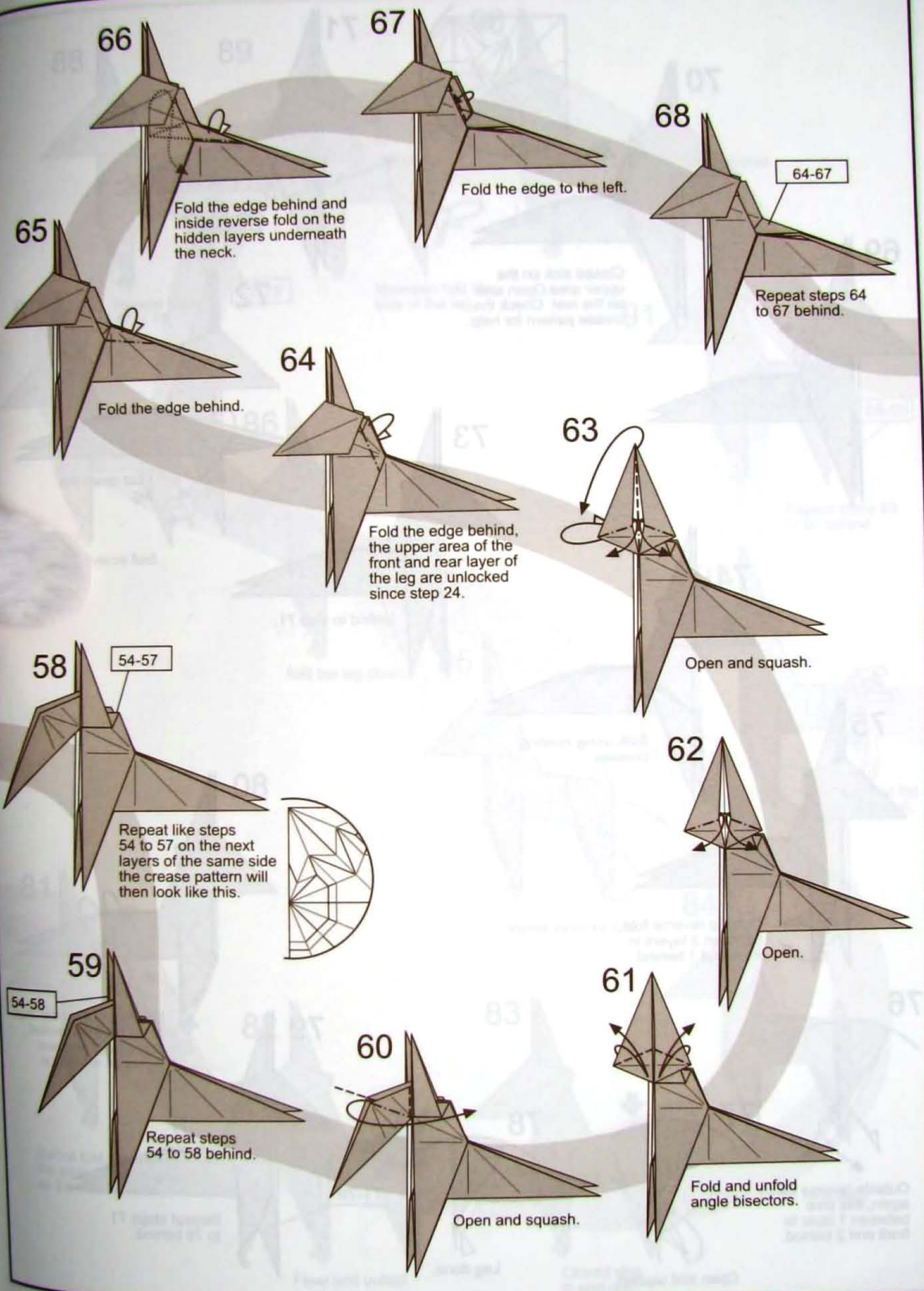

66
Fold the edge behind and inside reverse fold on the hidden layers underneath the neck.

67
Fold the edge to the left.

68
Repeat steps 64 to 67 behind.

65
Fold the edge behind.

64
Fold the edge behind, the upper area of the front and rear layer of the leg are unlocked since step 24.

63
Open and squash.

58
Repeat like steps 54 to 57 on the next layers of the same side the crease pattern will then look like this.

62
Open.

59
Repeat steps 54 to 58 behind.

60
Open and squash.

61
Fold and unfold angle bisectors.

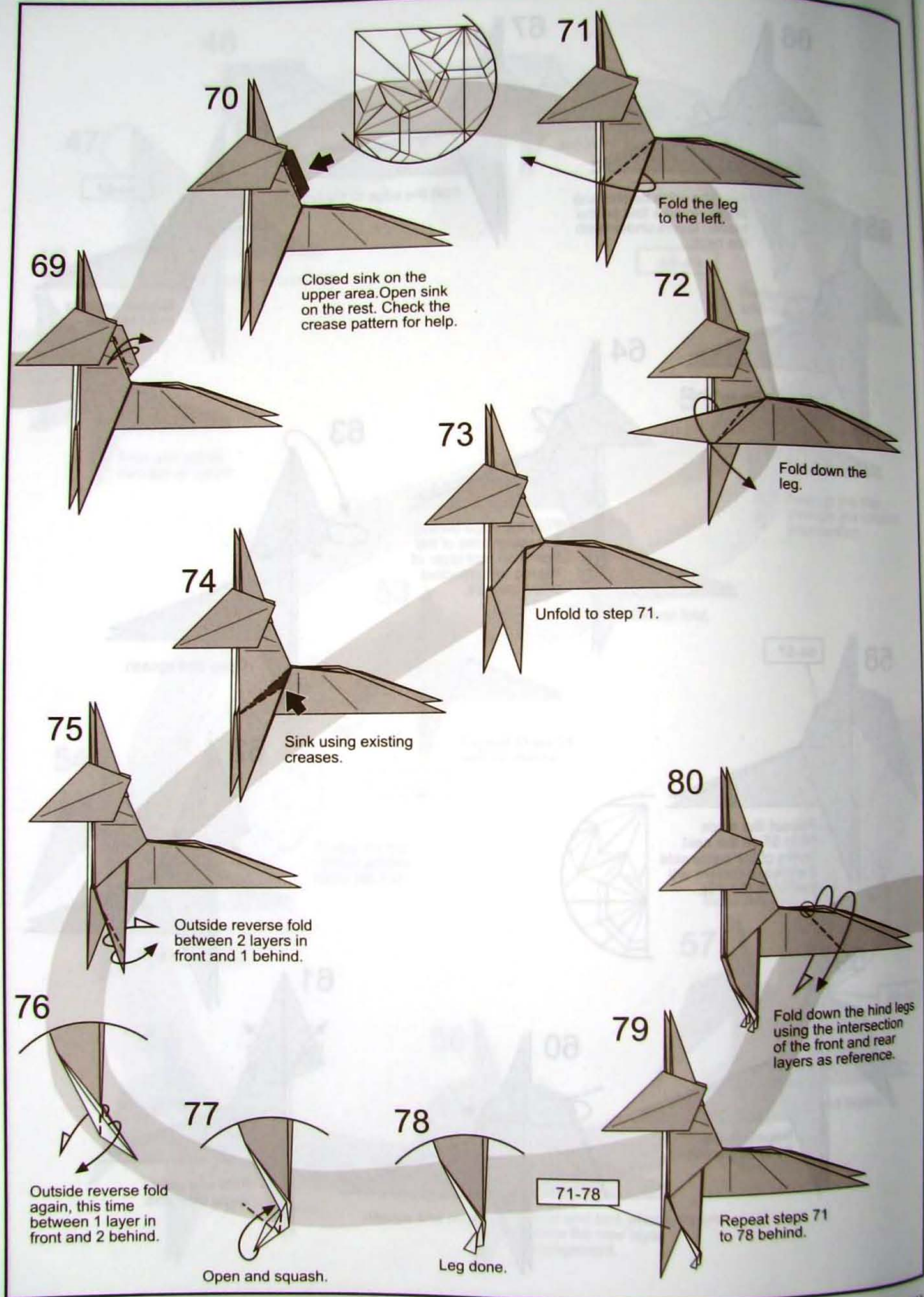

70

Closed sink on the upper area. Open sink on the rest. Check the crease pattern for help.

71

Fold the leg to the left.

69

72

Fold down the leg.

73

Unfold to step 71.

74

Sink using existing creases.

75

Outside reverse fold between 2 layers in front and 1 behind.

80

Fold down the hind legs using the intersection of the front and rear layers as reference.

76

79

Outside reverse fold again, this time between 1 layer in front and 2 behind.

77

78

Leg done.

Open and squash.

71-78

Repeat steps 71 to 78 behind.

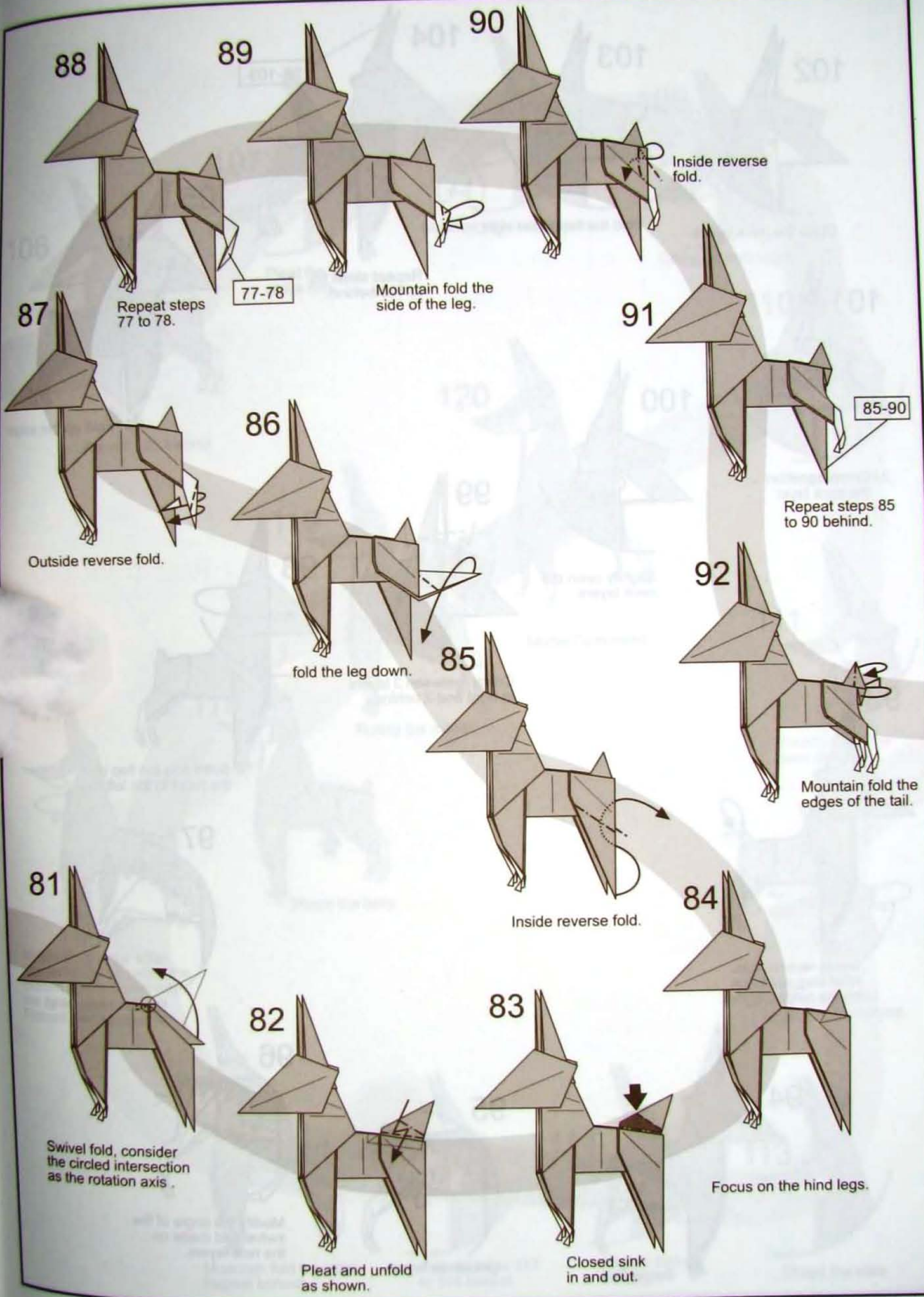

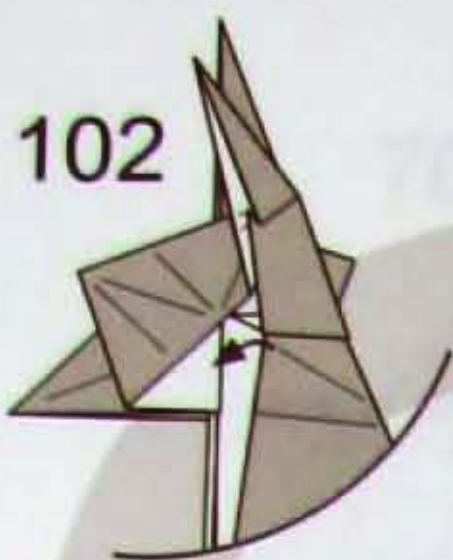

102 Close the neck layers.



103 Fold the flap to the right.

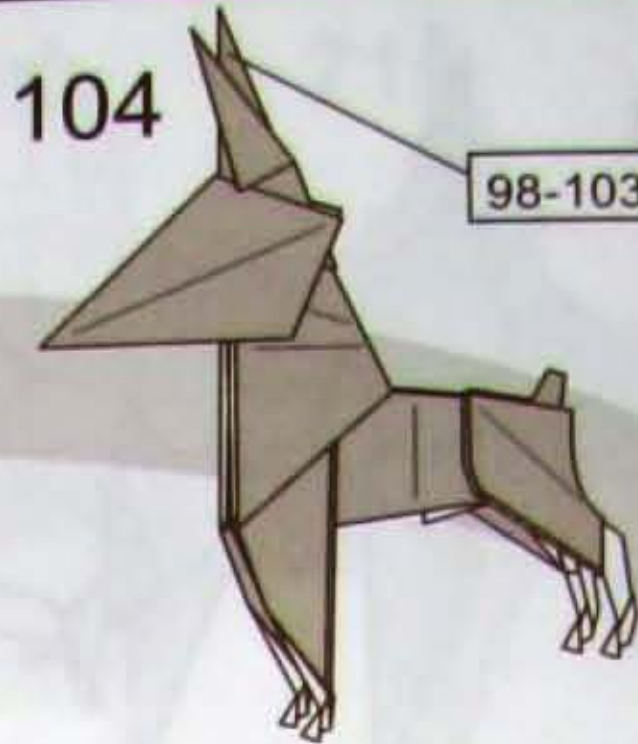

104 Repeat steps 98 to 103 behind.



105 Fold up the edge.

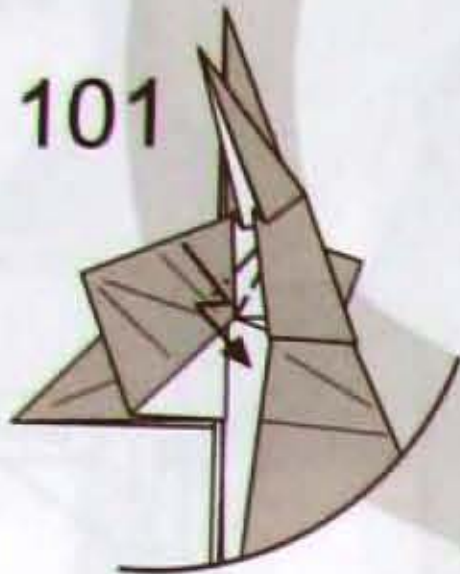

101 Crimp again on the back layer.

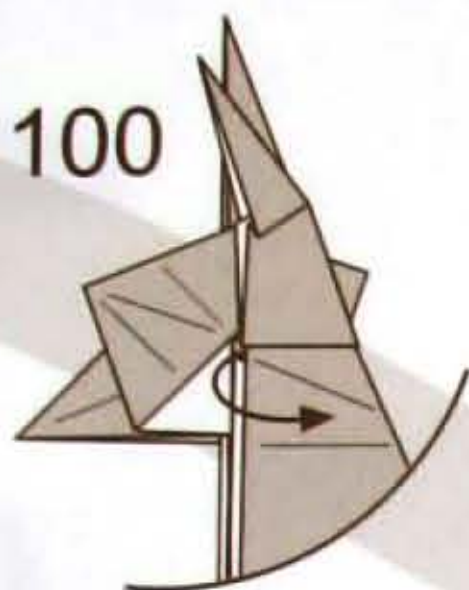

100 Slightly open the neck layers.

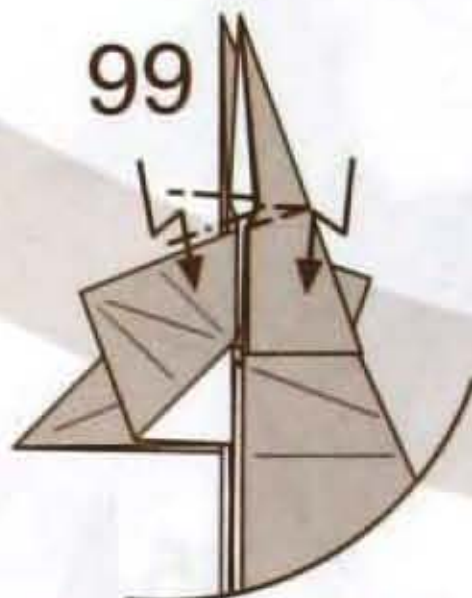

99 Crimp between 3 layers in front and 2 behind.

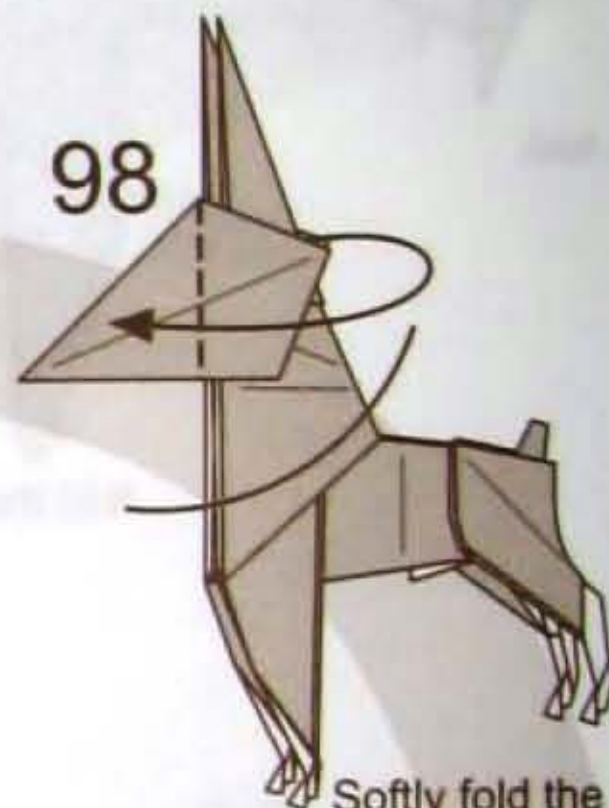

98 Softly fold the flap of the head to the left.

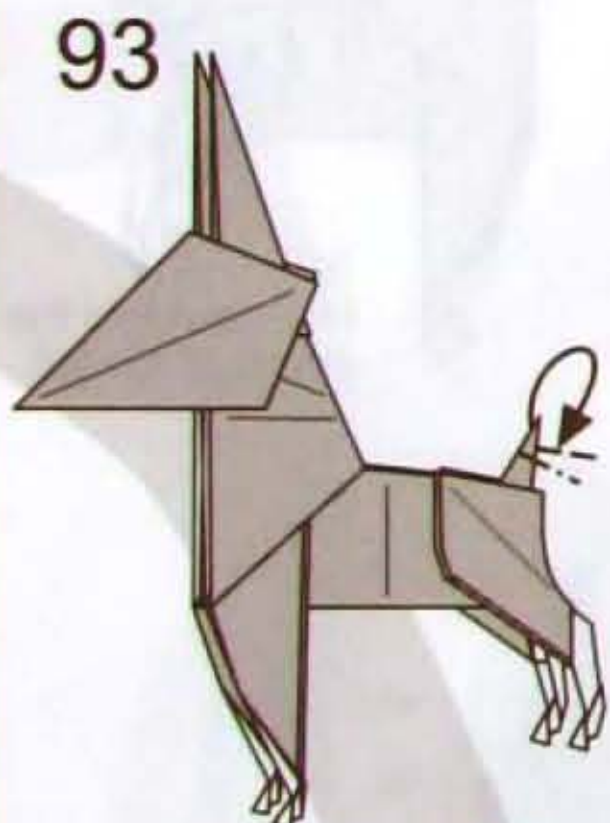

93 Inside reverse fold. Next step will focus on the hidden layers.



97 Repeat steps 94 to 96 in front.

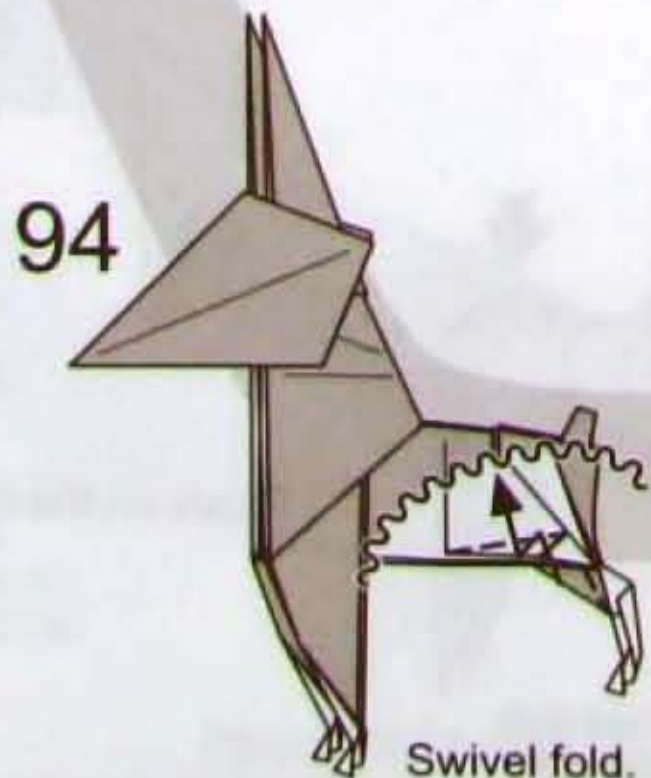

94 Swivel fold.

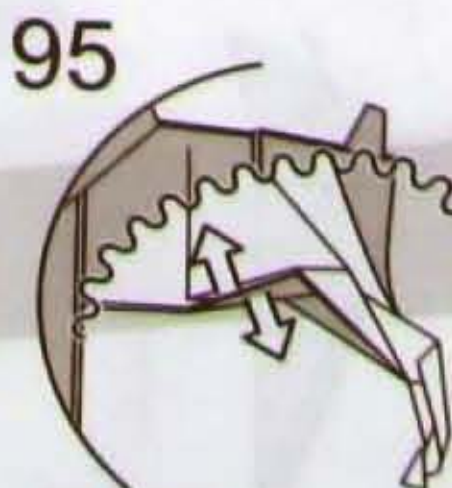

95 Unlock de layers.



96 Modify the angle of the swivel fold made on the rear layers.

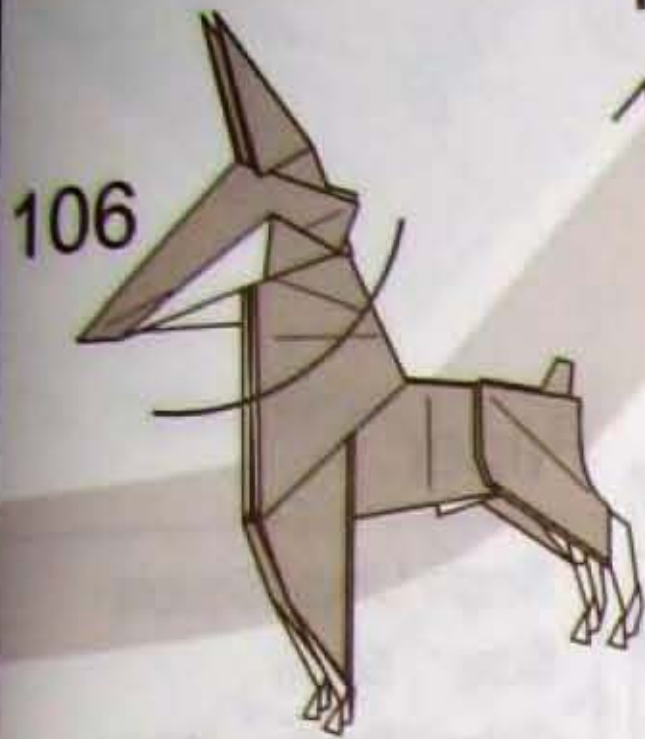

106

Repeat 105 behind.



107

Pleat the tip of the flap.



108

Mountain fold the corners.

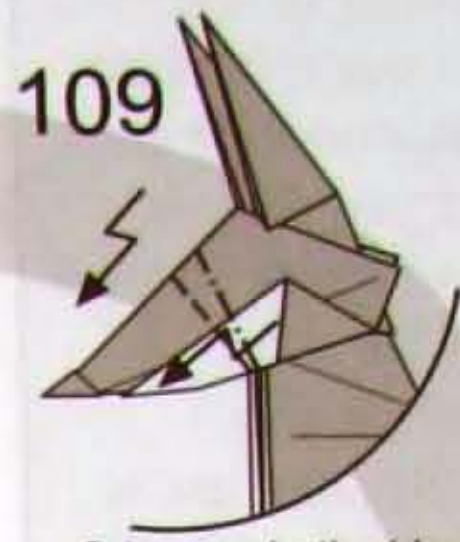

109

Crimp on both sides.

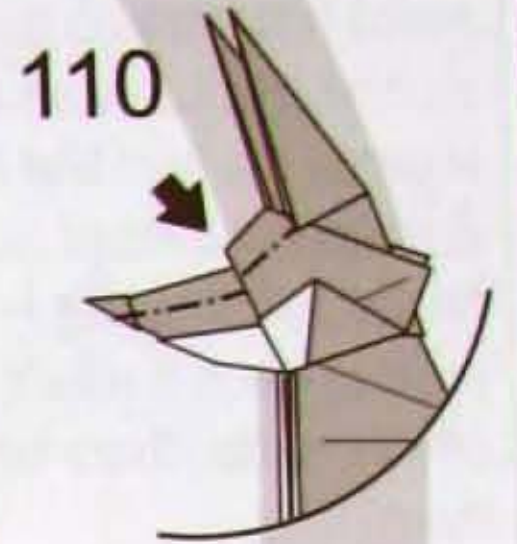

110

Shape the head.



120

Model Completed.



119

Rotate the model.

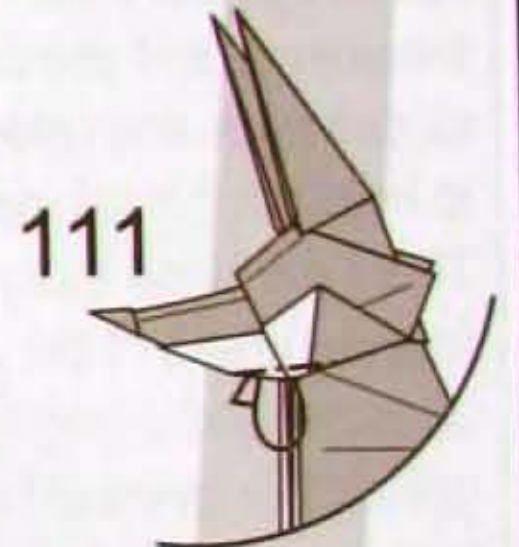

111

Mountain fold the lower corners.



117

Mountain fold the edge. You will have to swivel the hidden layers underneath the head and neck. Repeat behind.

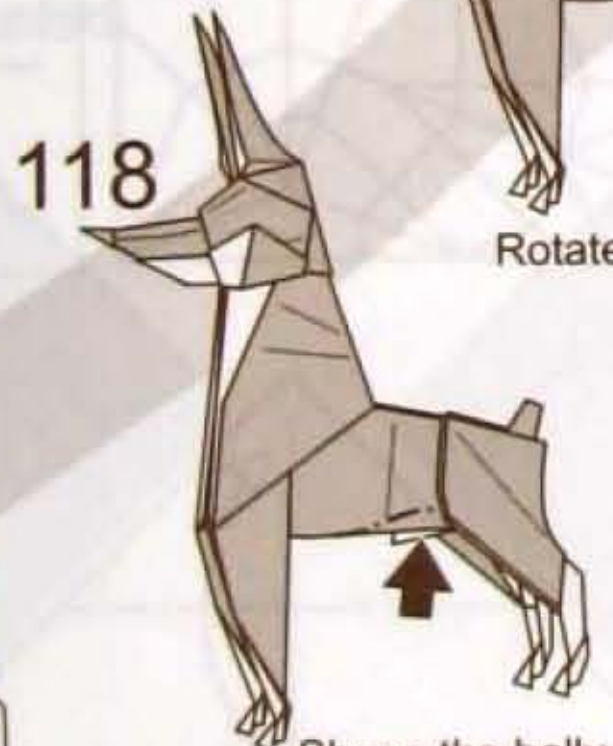

118

Shape the belly.

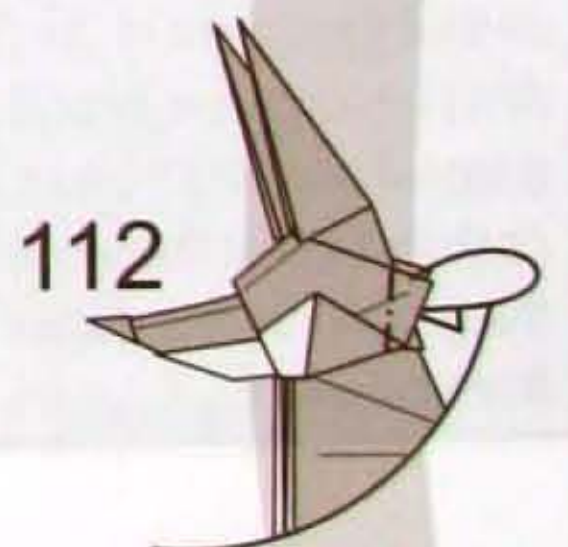

112

Mountain fold the edge. Repeat behind.



116

Mountain fold the edge. Repeat behind.



115

Repeat steps 113 to 114 behind.



114

Slightly fold up the edge.



113

Shape the ears.

Japão Burajirujin
www.japaoburajirujin.blogspot.com

Babirusa

The first time my friend Pavel suggested this strange animal to me, I thought it was impossible for such a bizarre creature to exist! However, they do exist naturally in a vulnerable status in a small area of S.E. Asia.

The obvious outstanding features of the Babirusa are its distinctive upper canines (in the male) that grow up through the muzzle and curve backward. In legends it is said that the Babirusa use these canines to hang itself on a tree branch at night to sleep (I mean, what other use can there be for them?).

Apart from the two sets of canines, I also wanted to achieve all the other details of the animal, and preferably with a closed-back and color-changes to highlight the canines.

There are some tricky sinks to free the layers of the ears (steps 30 to 34) and a long sequence of getting the layers of the front legs to sit outside of the body (steps 41 to 62).

Use a thin and strong paper so that the layers of the tusks don't become too thick. I also suggest shaping it into a grazing posture so that the jaw sits on the ground as it is quite front-heavy.

Babirusa

Quentin Trollip

South Africa / Canada

www.liveorigami.com

Design and diagram info:

Date: 28 January 2011

Difficulty: Complex

Time to fold: 2 hours

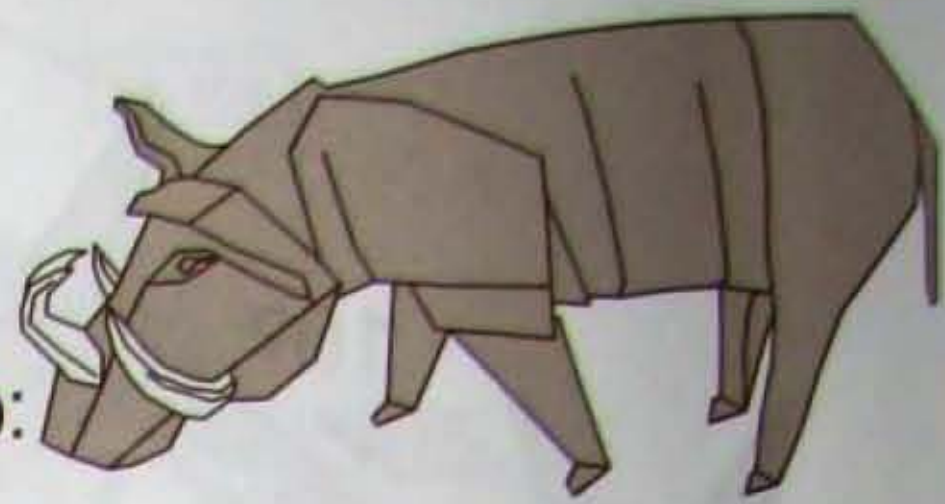

Crease Pattern:

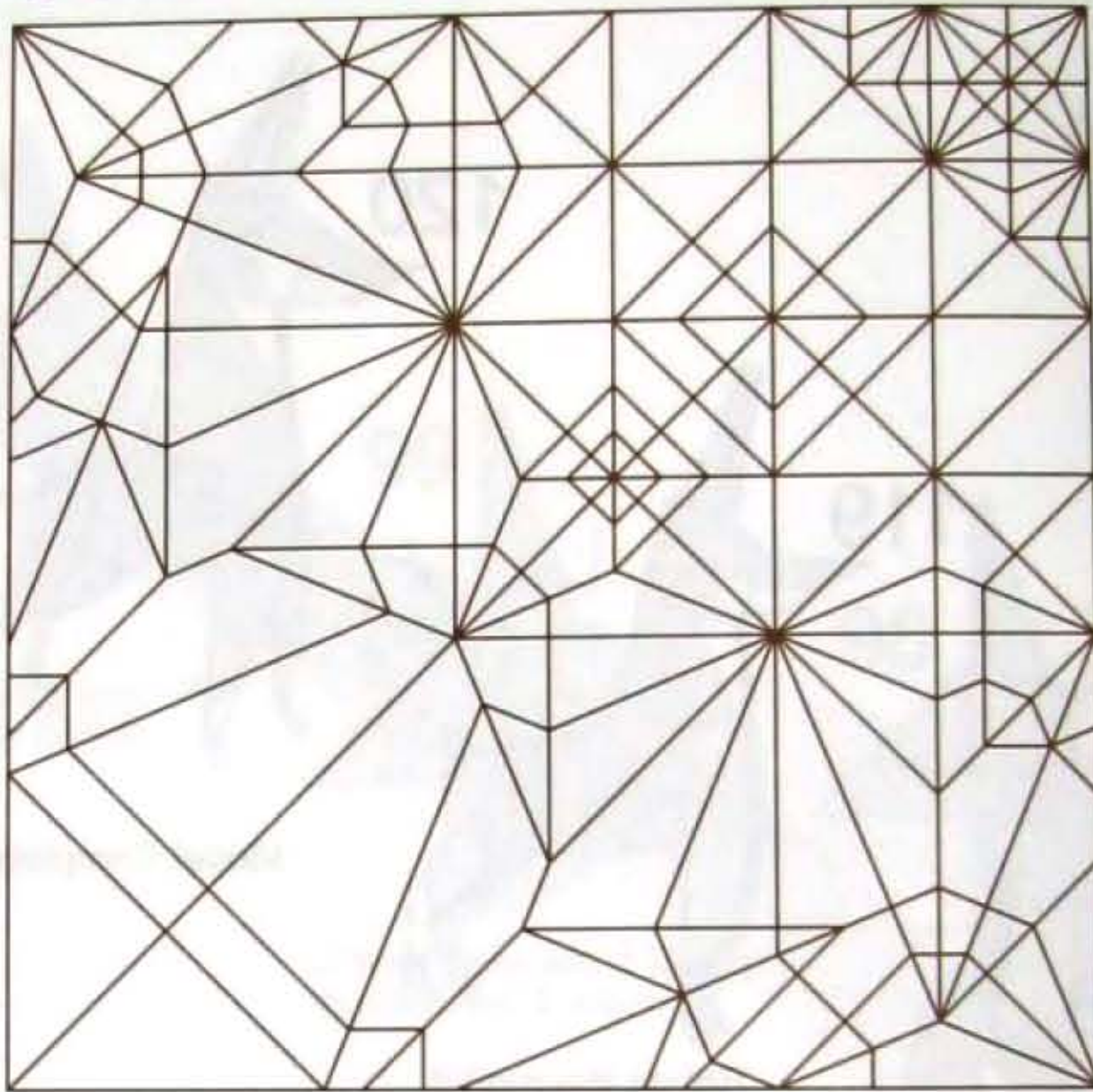

Paper:

Single Uncut Square

Size: 50cm

Color: Brown - White

Type: Kami

Foil

Wet-Fold

No
OK
Best

Ratio: 0.33 Length

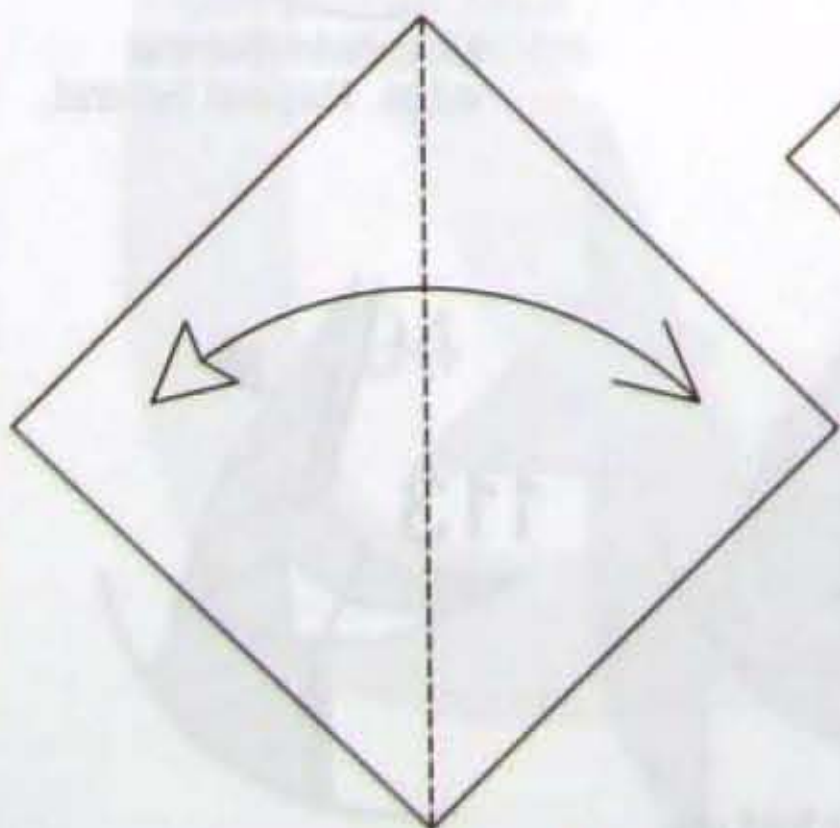
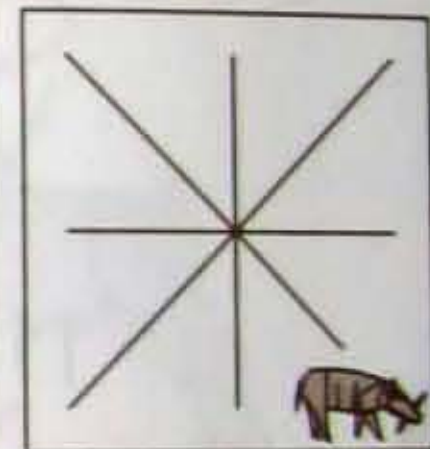

1. Valley-fold and unfold.

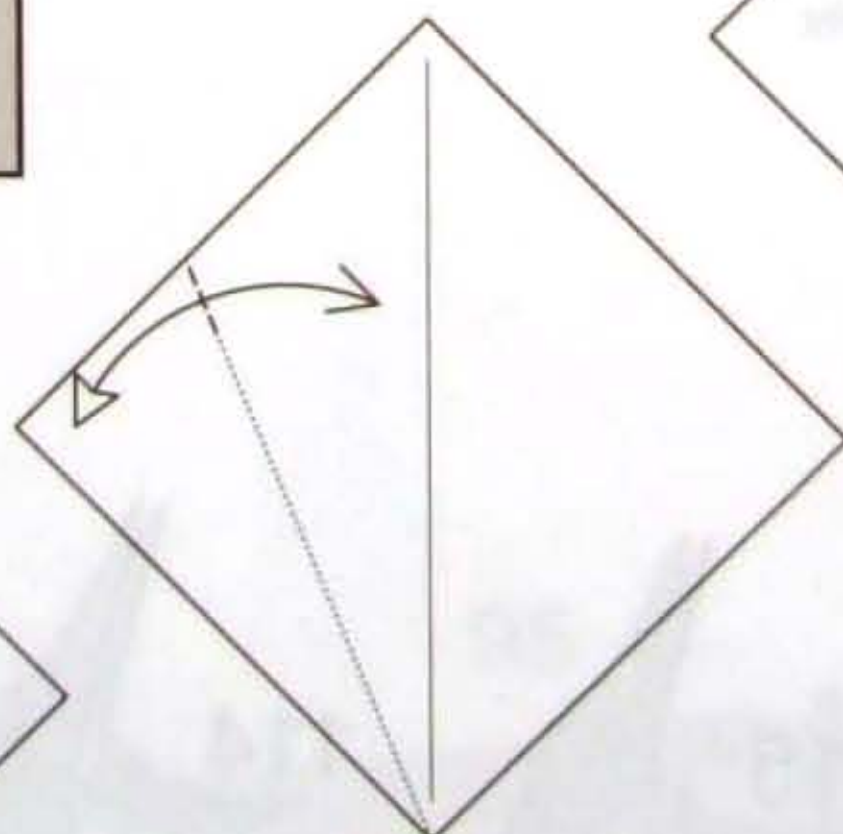

2. Pinch.

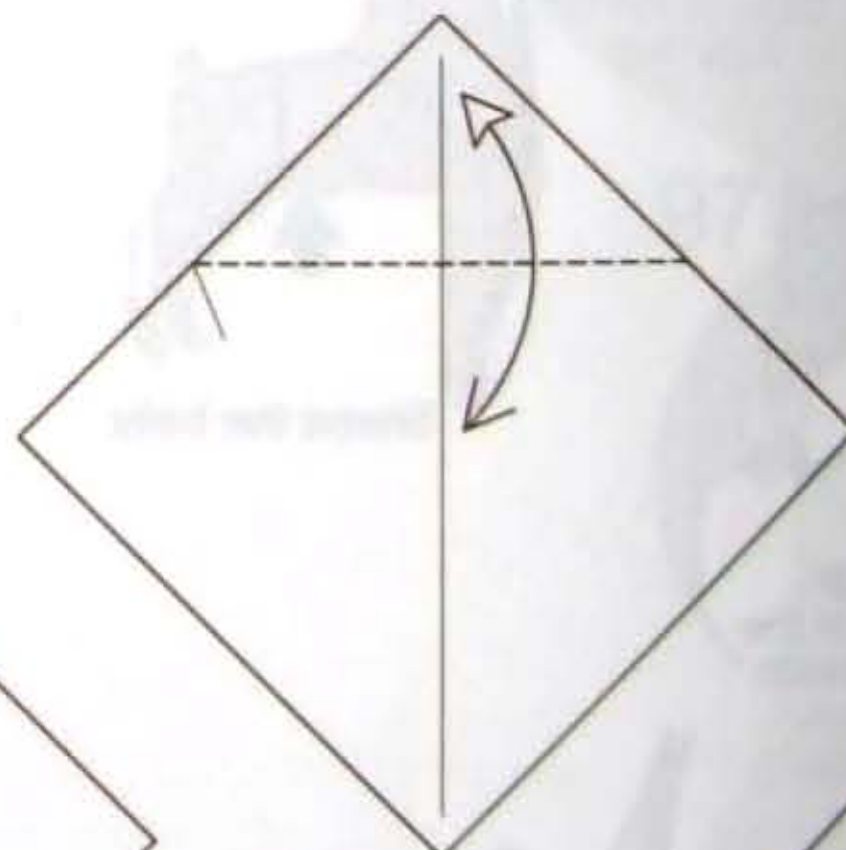

3. Valley-fold and unfold.

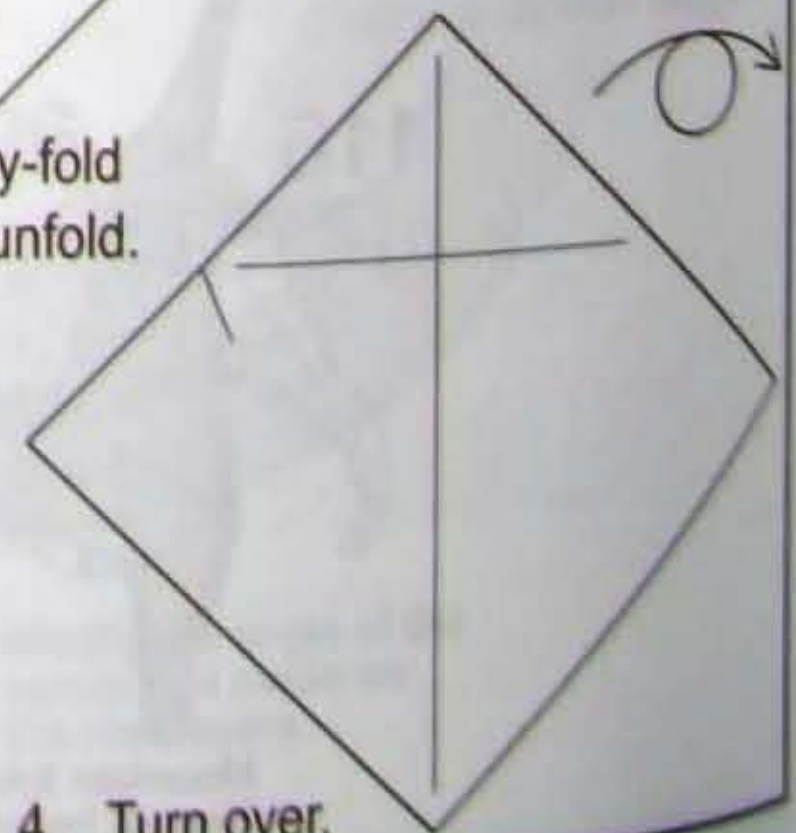

4. Turn over.

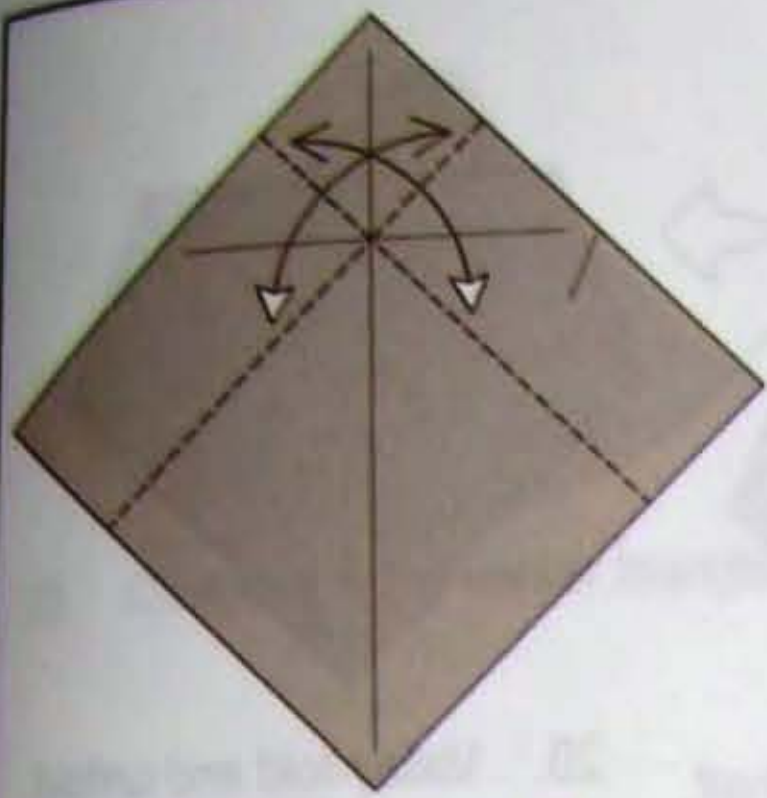

5. Valley-folds and unfold.

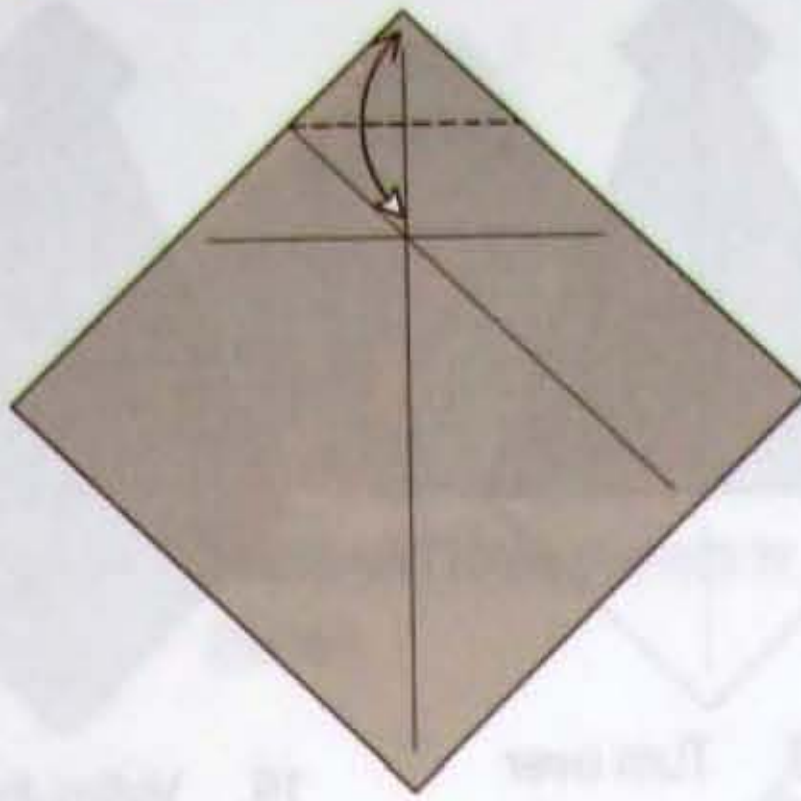

6. Valley-fold and unfold.

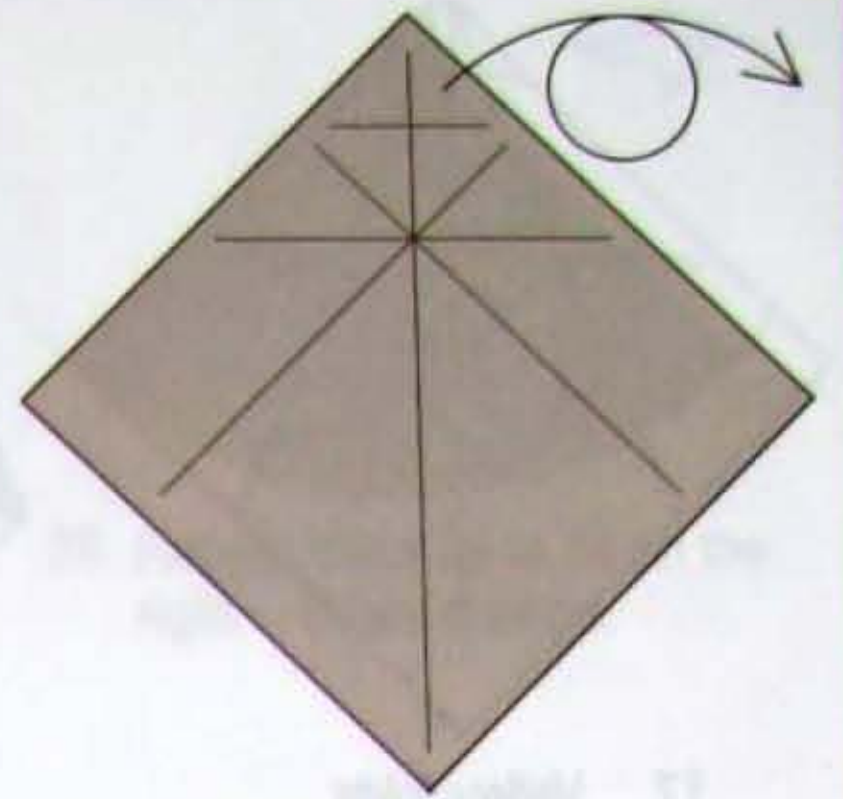

7. Turn over.

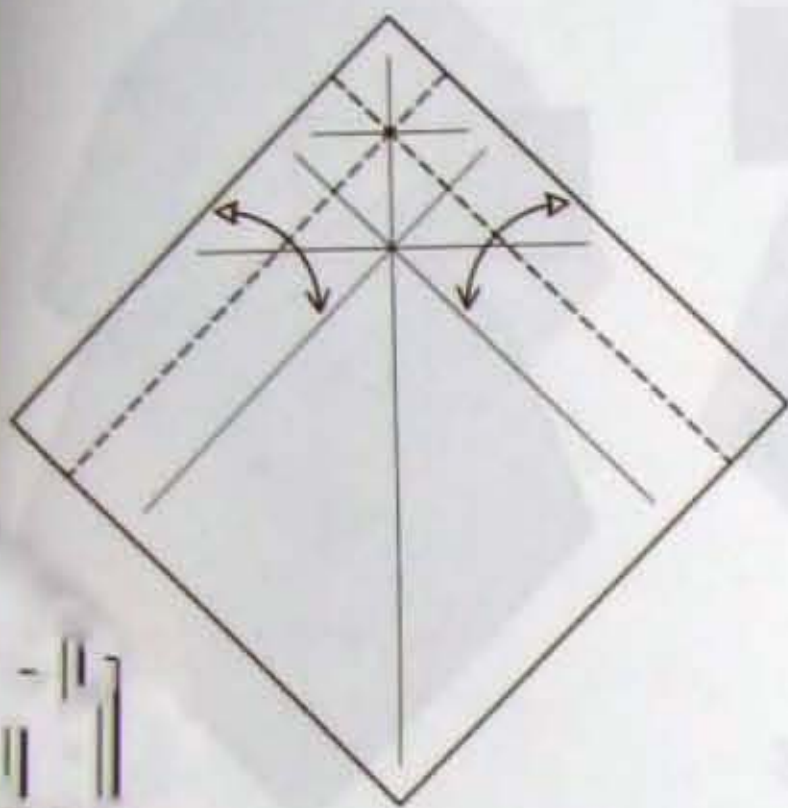

8. Valley-folds and unfold.

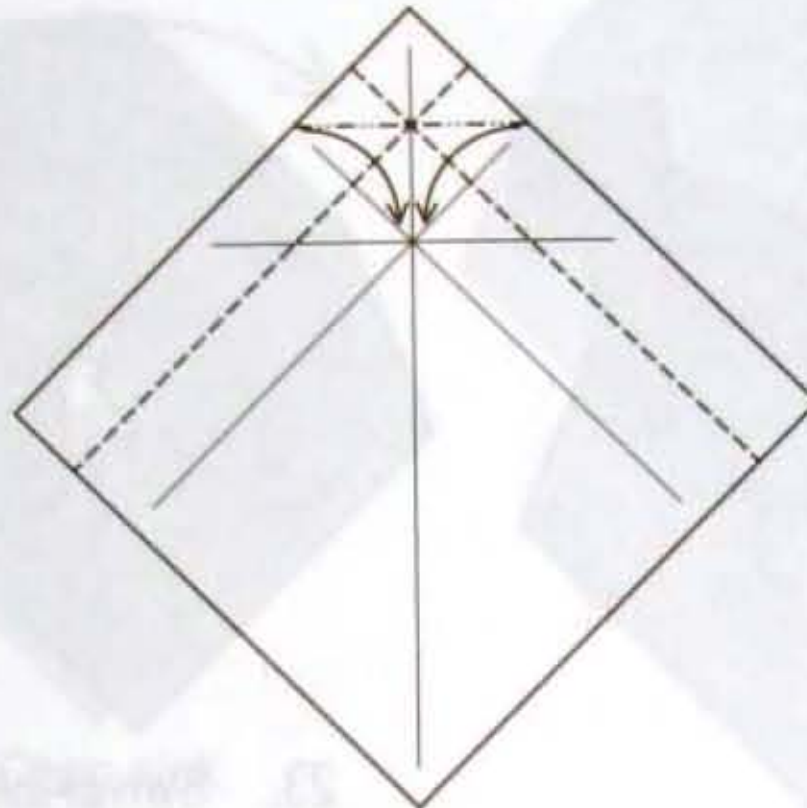

9. Preliminary-fold.

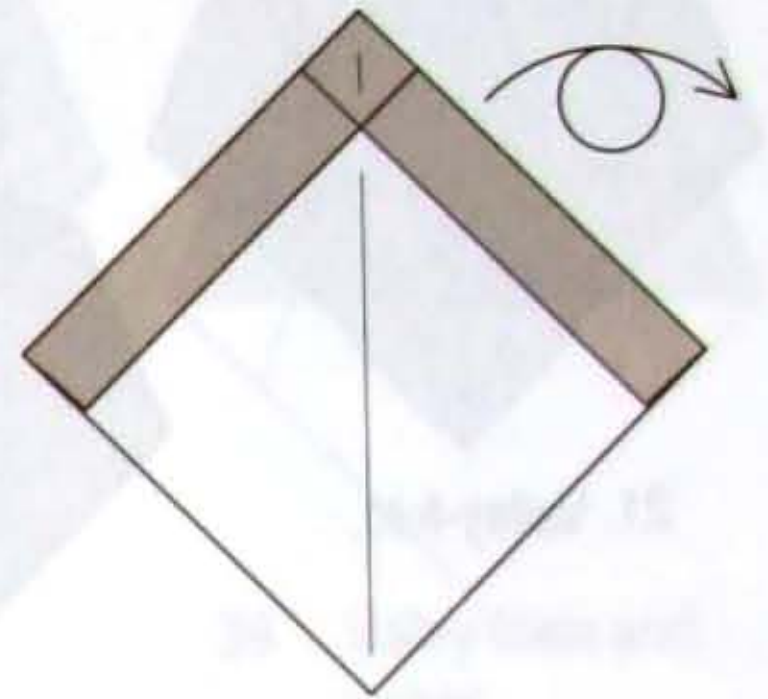

10. Turn over.

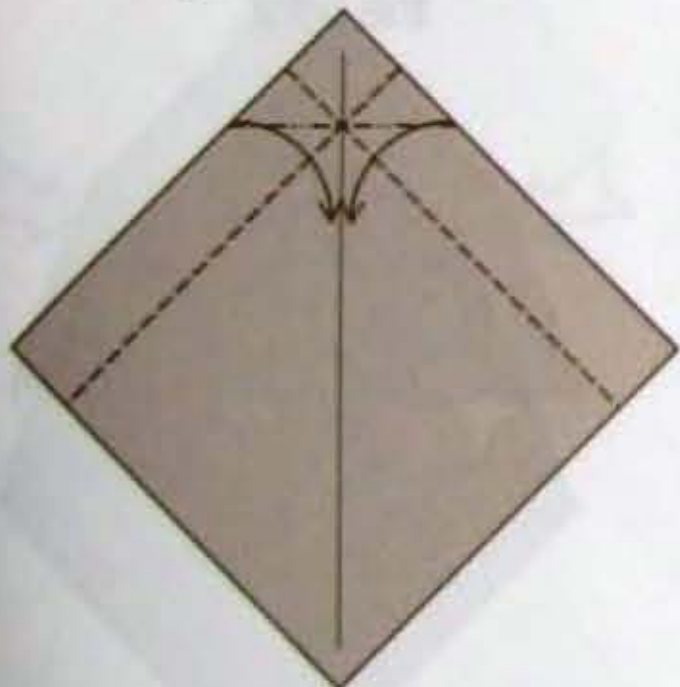

11. Preliminary-fold.

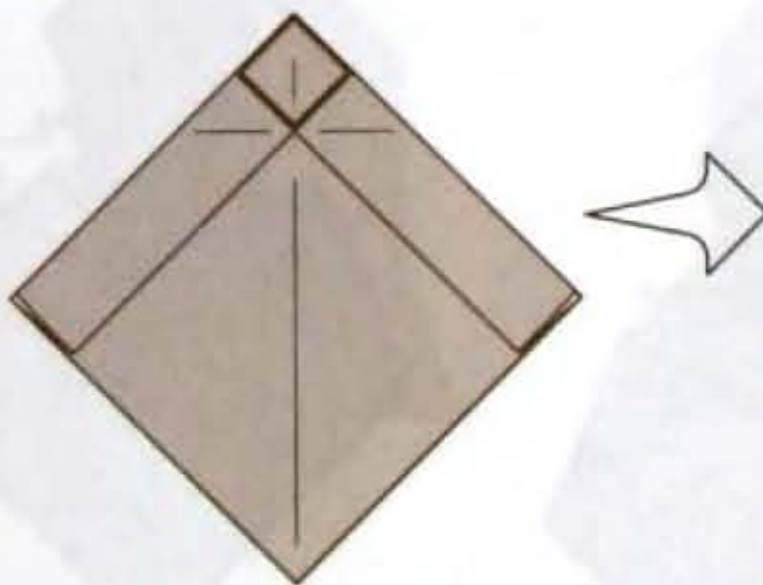

12. Enlarge.

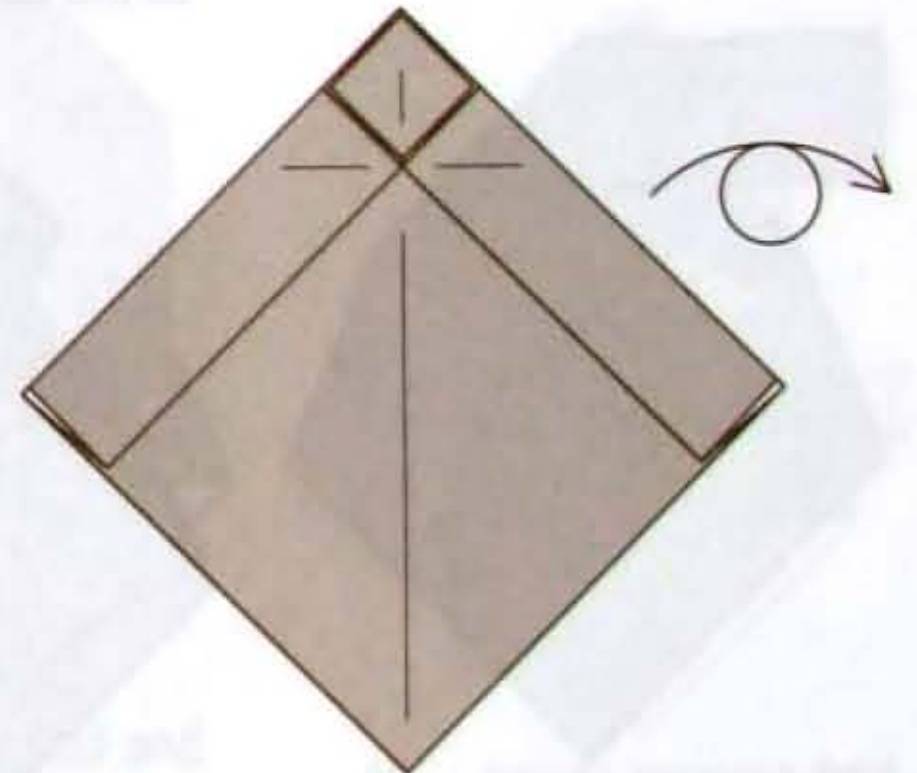

13. Turn over.

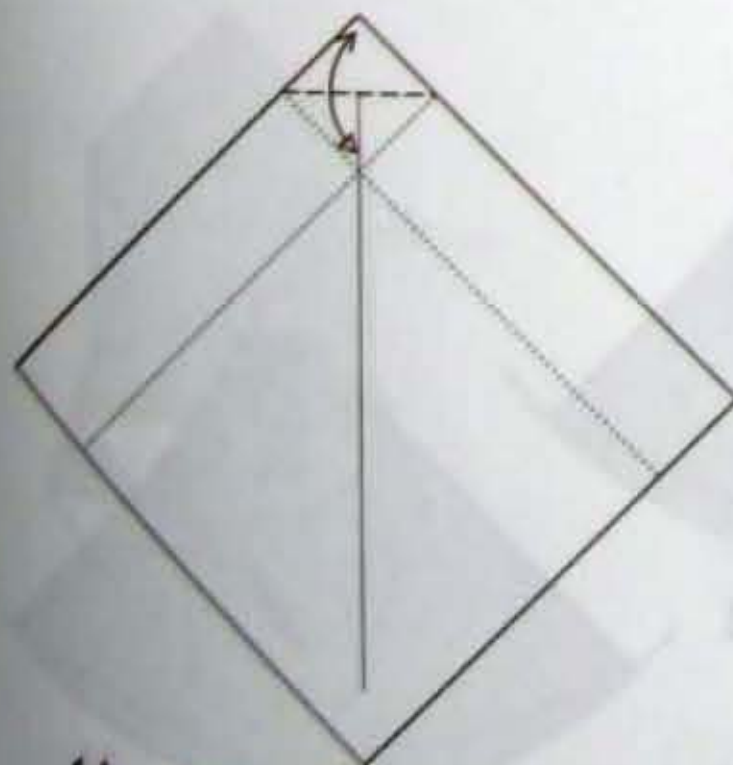

14. Valley-fold and unfold.

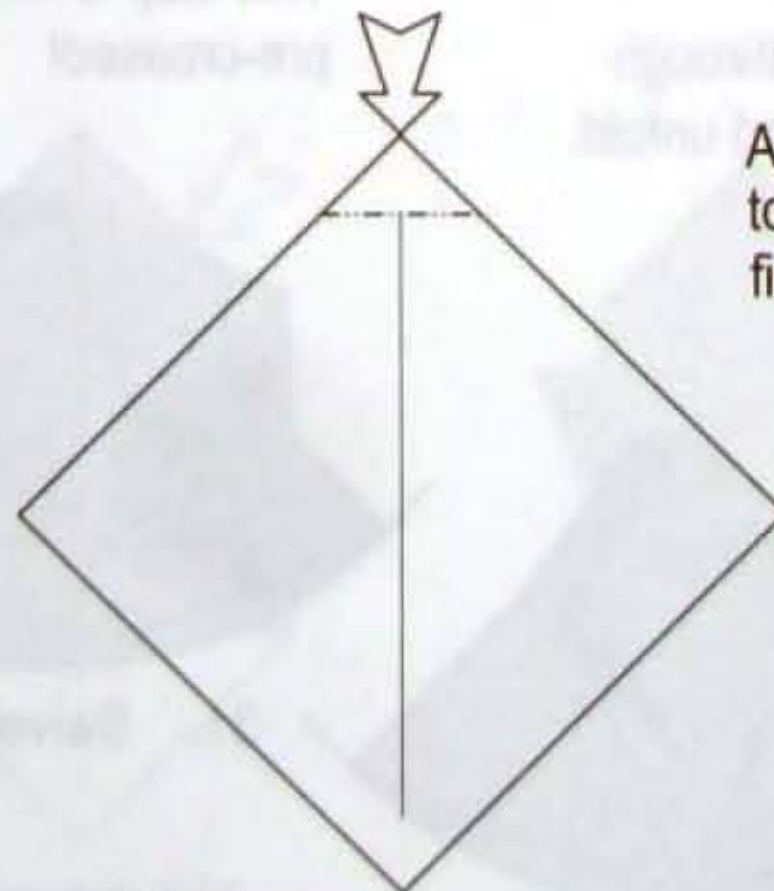

15. Open-sink.

Apply some tape here to prevent ripping in the final folds.

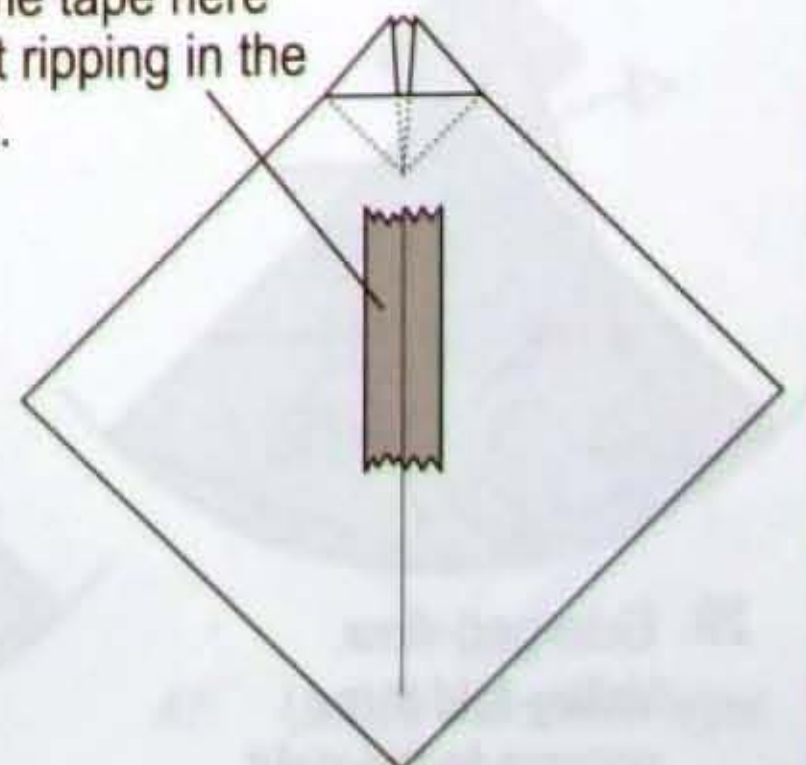

16. The result.

square

White

te

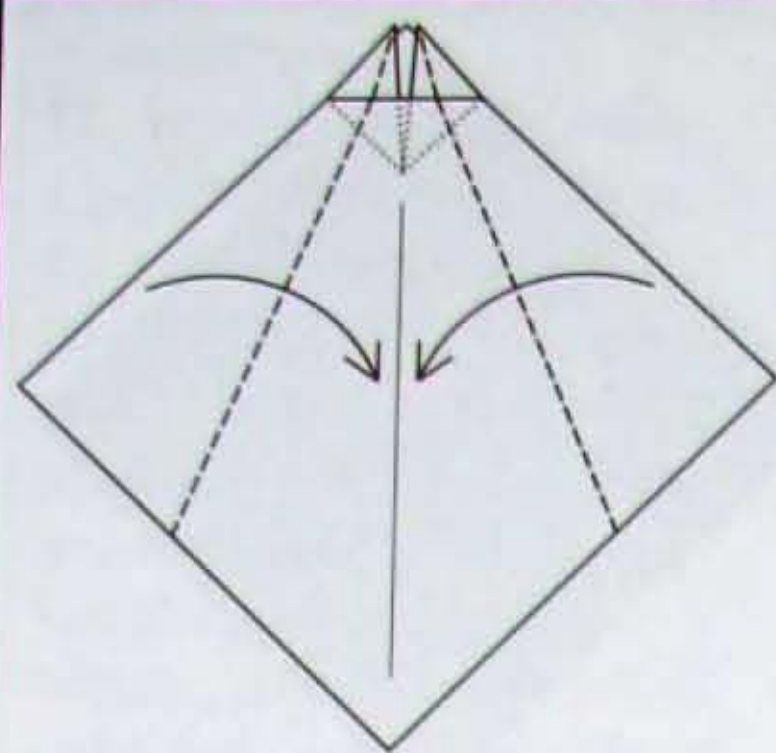

17. Valley-folds.

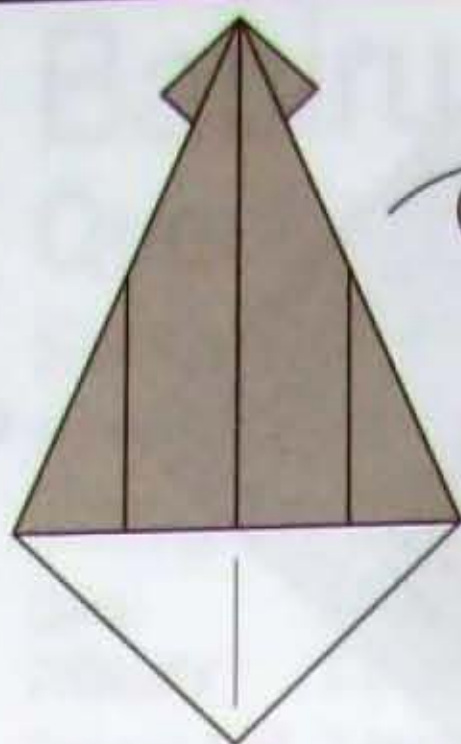

18. Turn over.

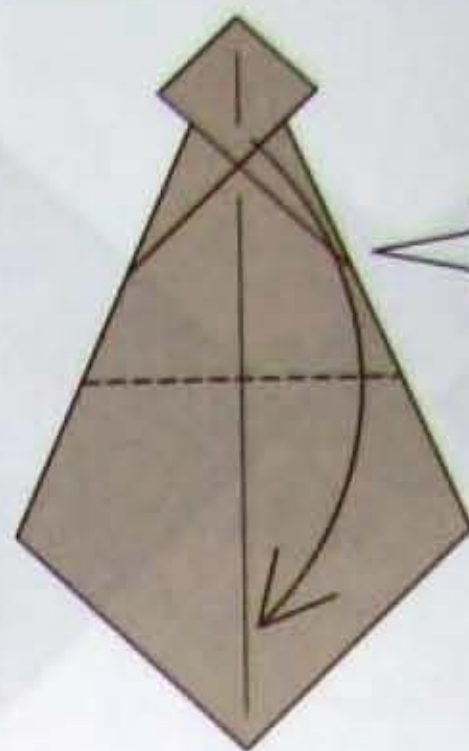

19. Valley-fold in half.

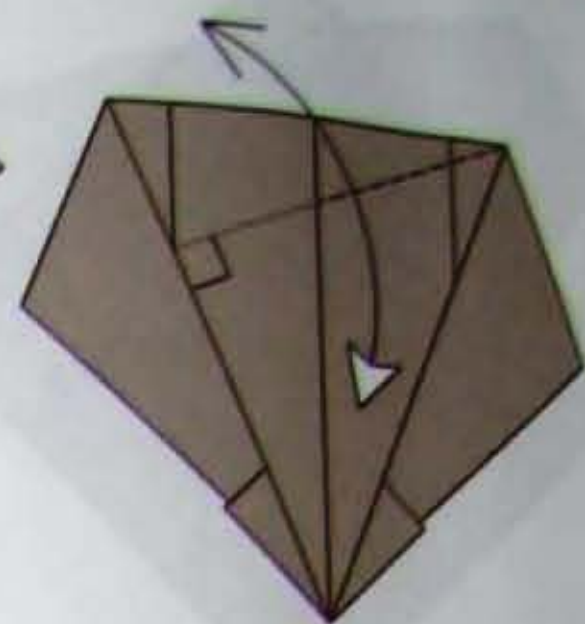

20. Valley-fold and unfold.

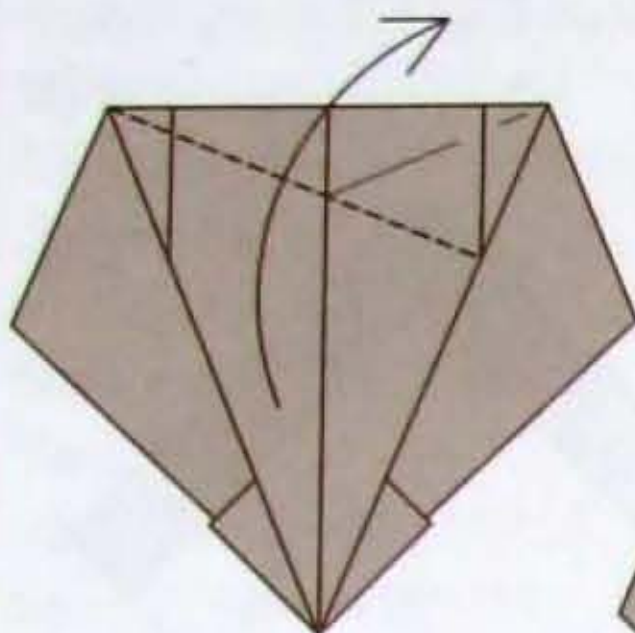

21. Valley-fold.

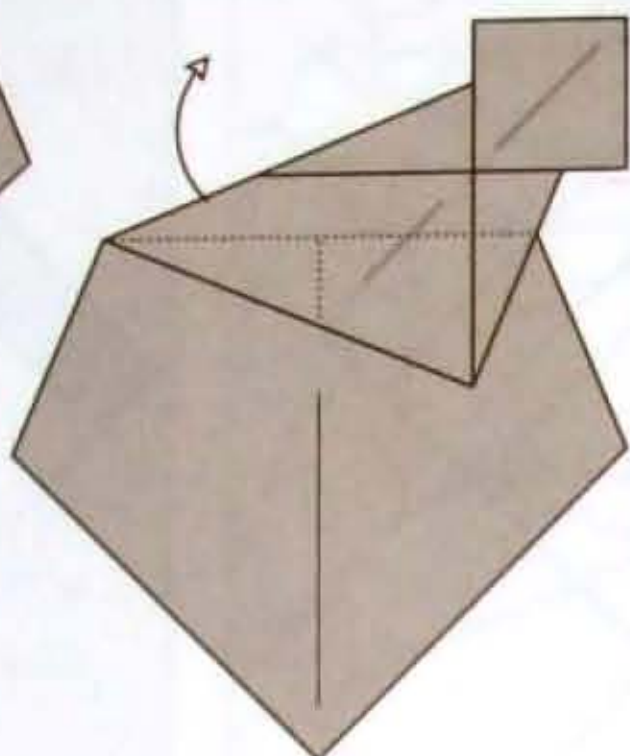

22. Pull out the layers at the back.

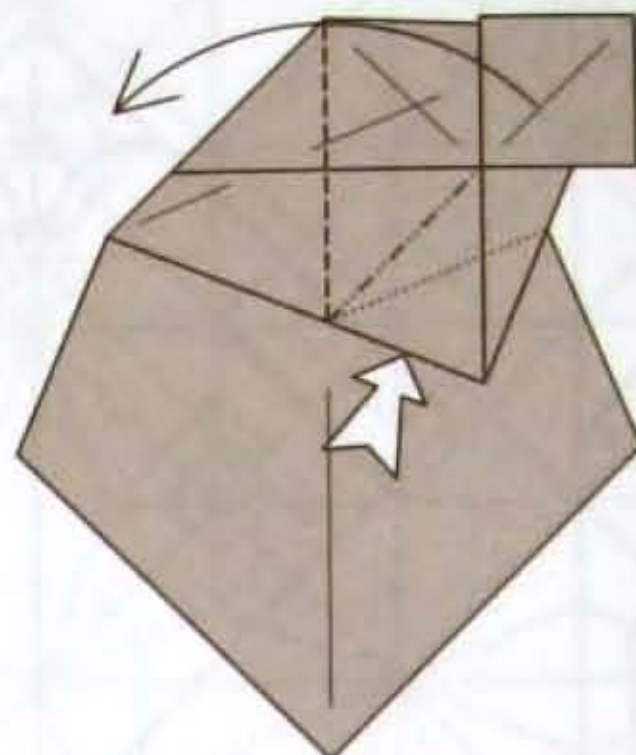

23. Swivel-fold.

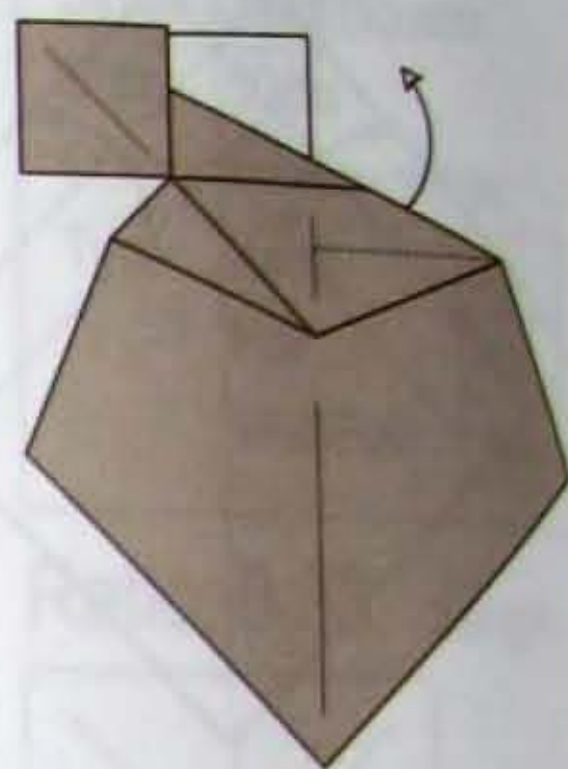

24. Pull out the layers at the back.

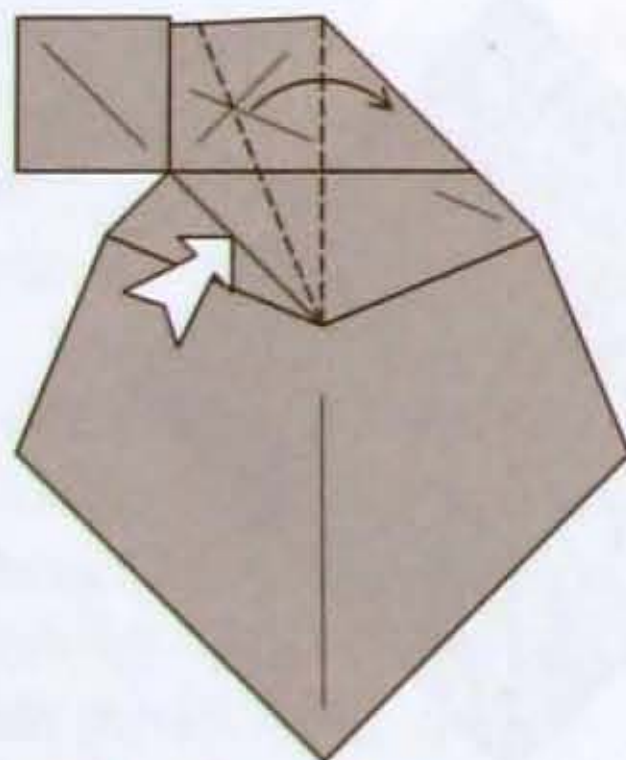

25. Squash-fold.

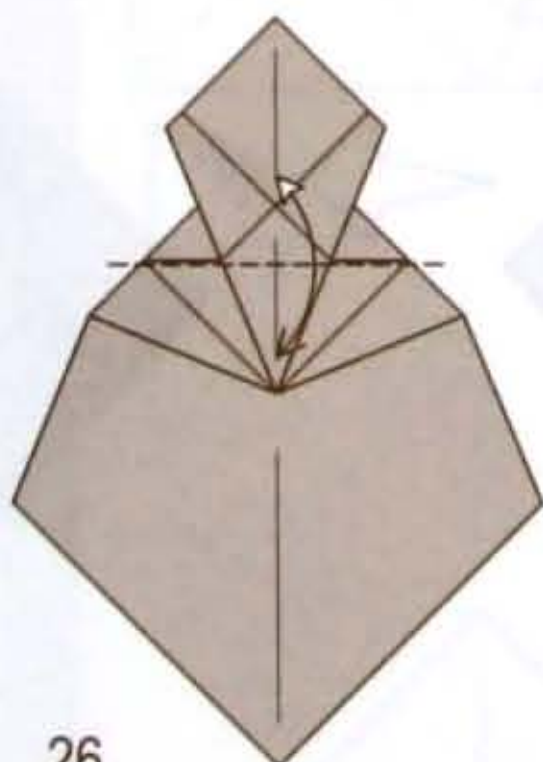

26. Valley-fold through all layers and unfold.

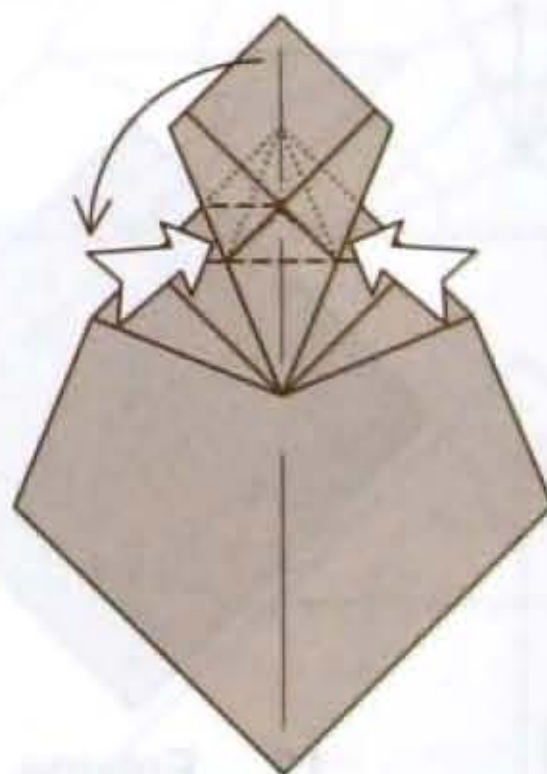

27. Petal-fold to the left. This step is not pre-creased!

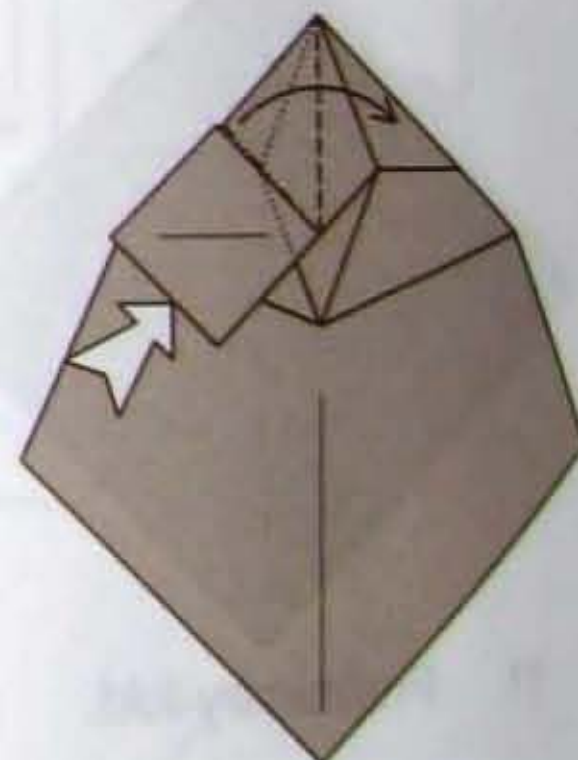

28. Squash-fold.

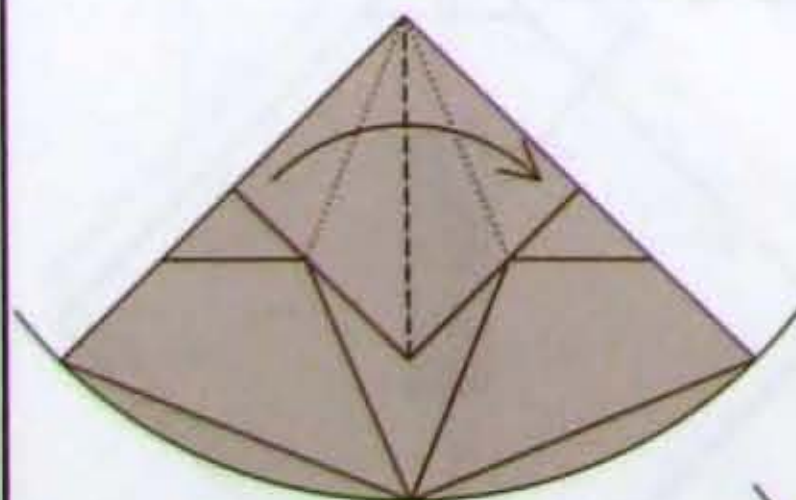

29. Enlarged view. Valley-fold three corners to the right

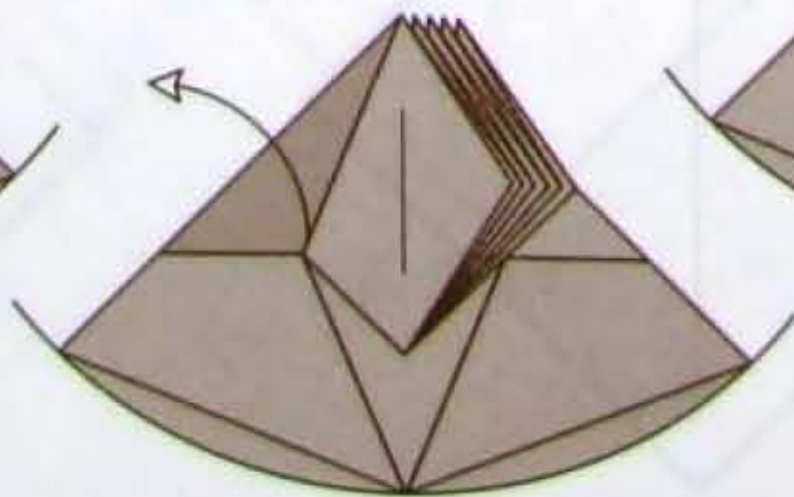

30. Pull out the layer.

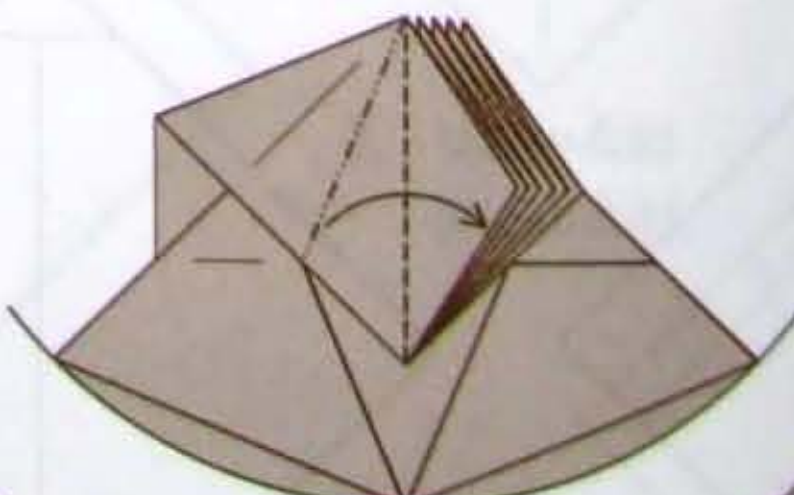

31. Swivel-fold.

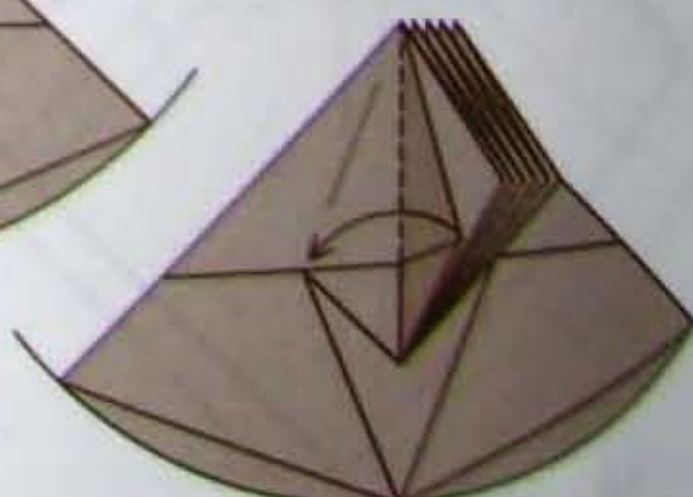

32. Valley-fold.

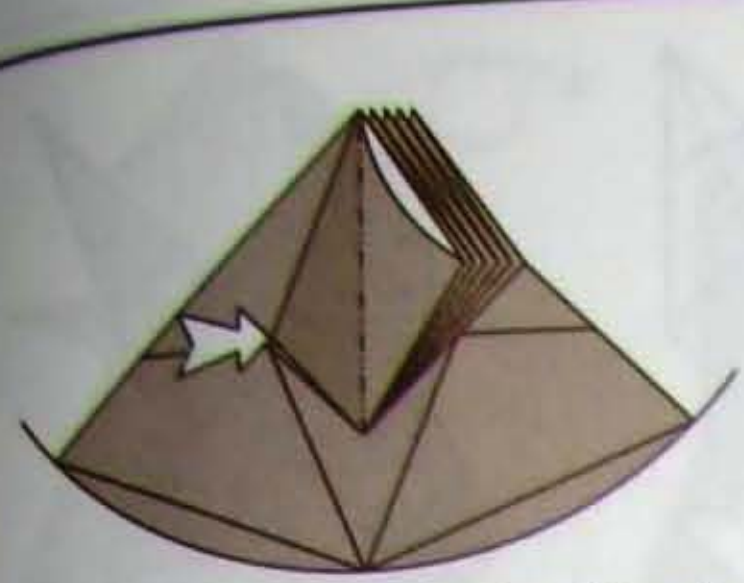

33. Closed-sink the darker triangle.

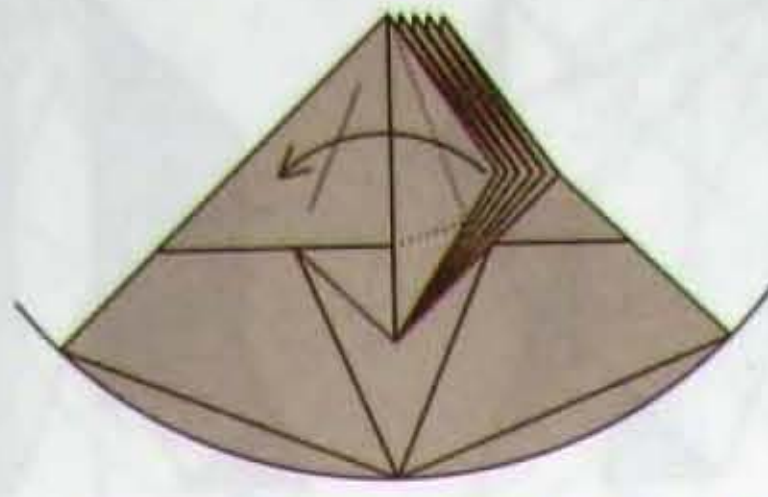

34. Valley-fold three corners to the left.

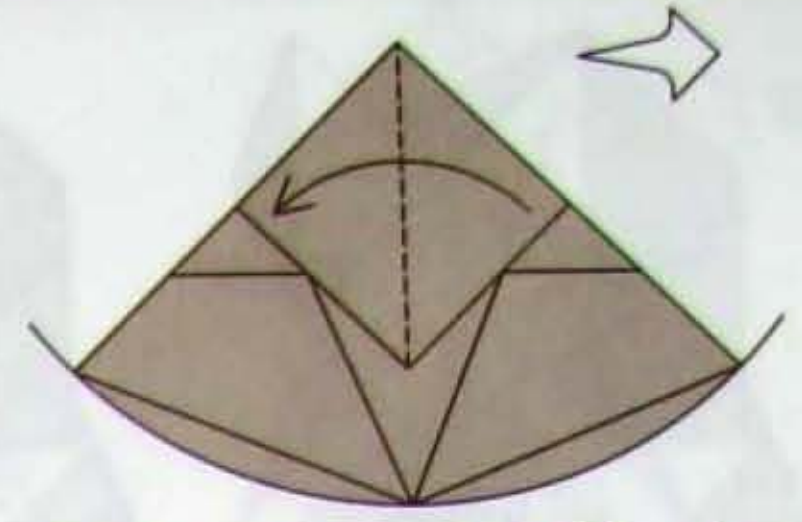

35. Repeat steps 29 to 34 on the right. Scale change.

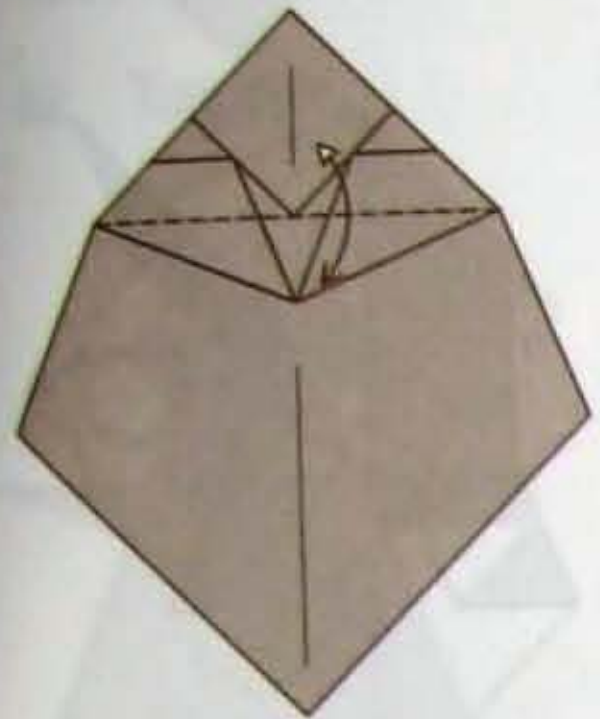

36. Valley-fold and unfold.

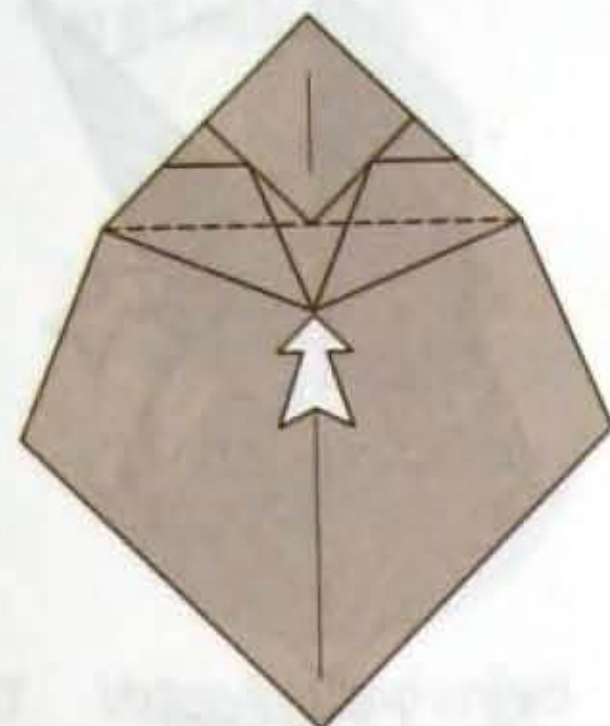

37. Open-sink.

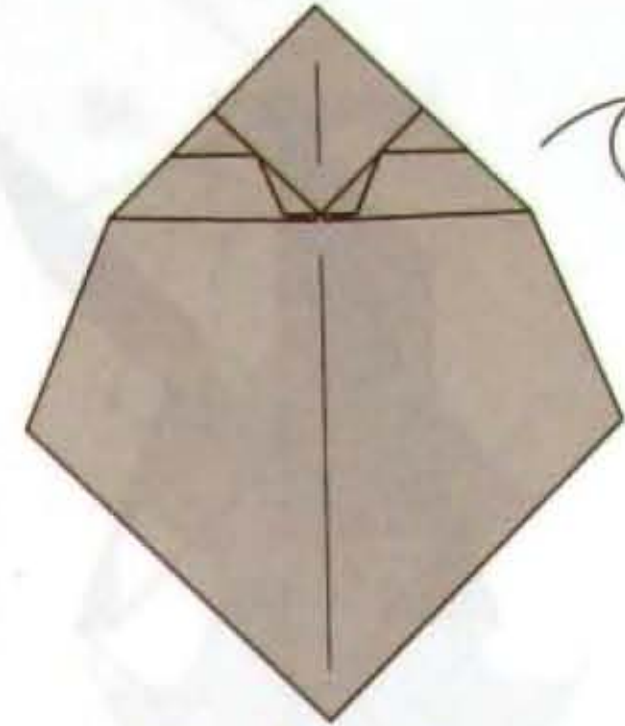

38. Turn over.

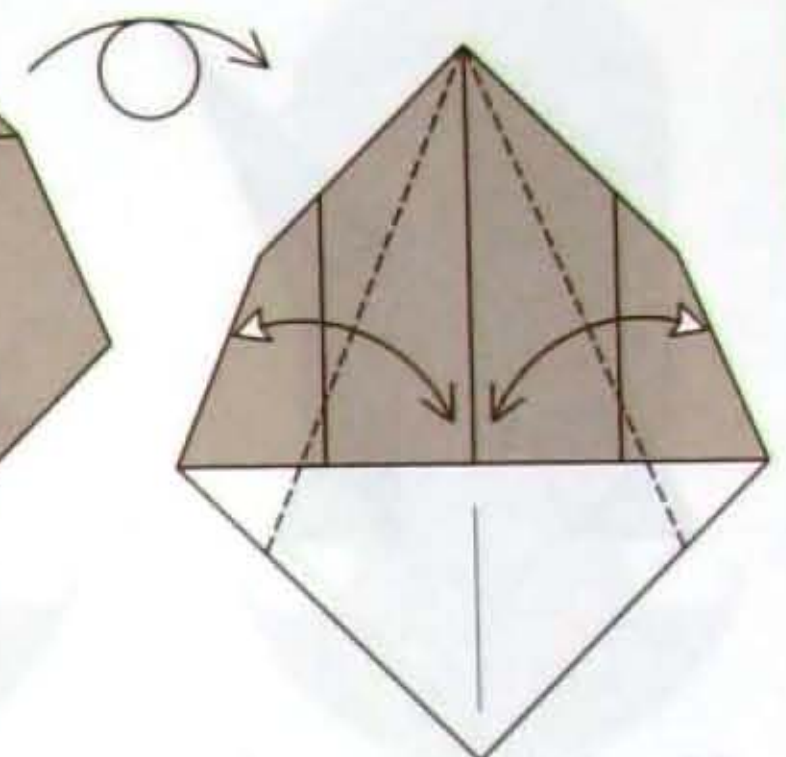

39. Valley-folds and unfold.

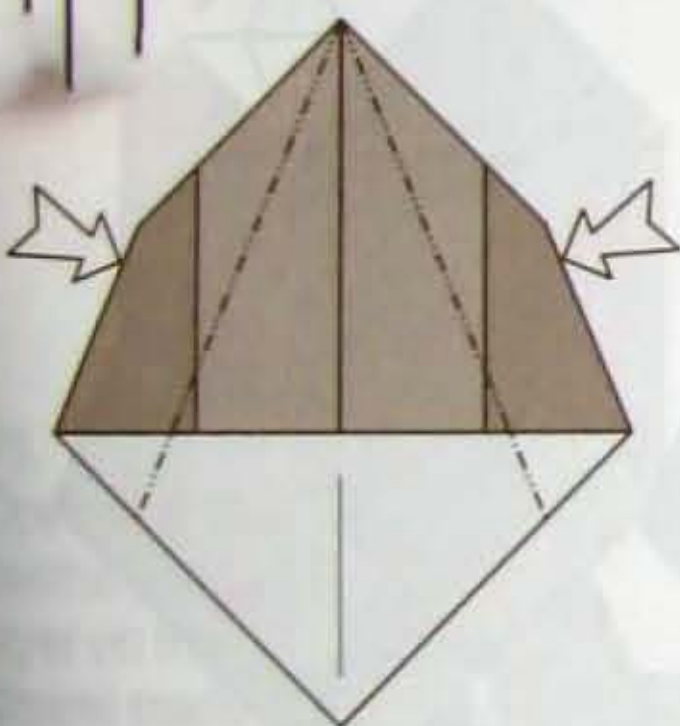

40. Closed-sink the lower layers only.

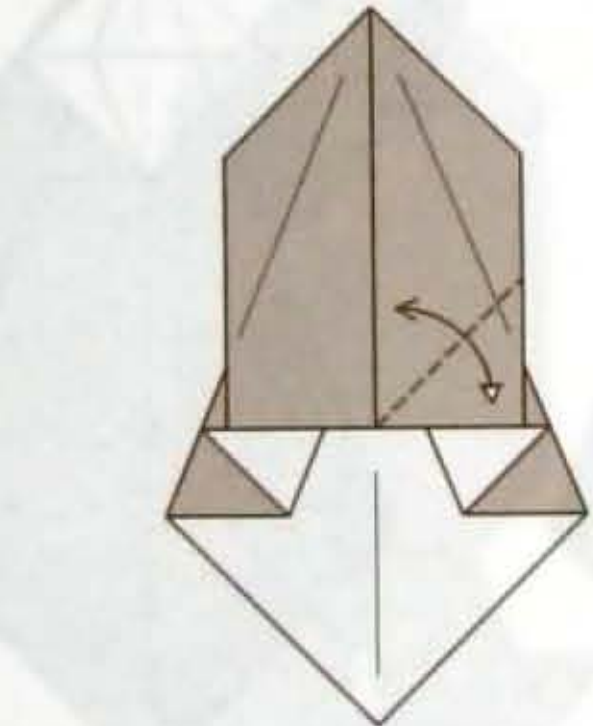

41. Valley-fold and unfold.

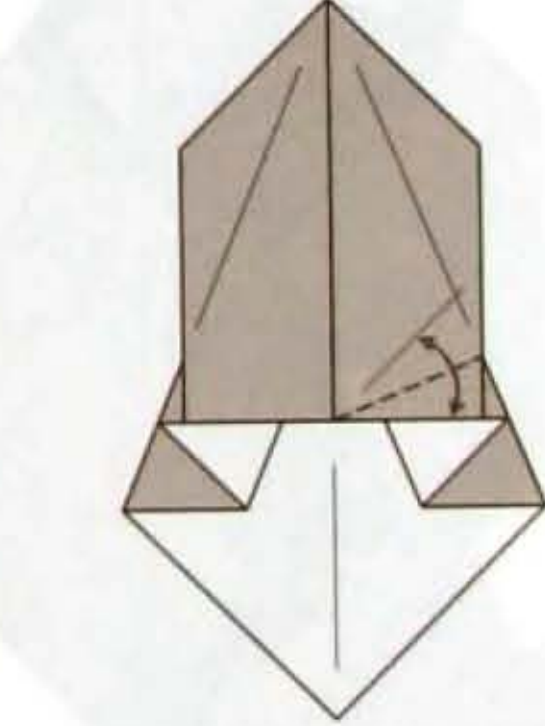

42. Valley-fold and unfold.

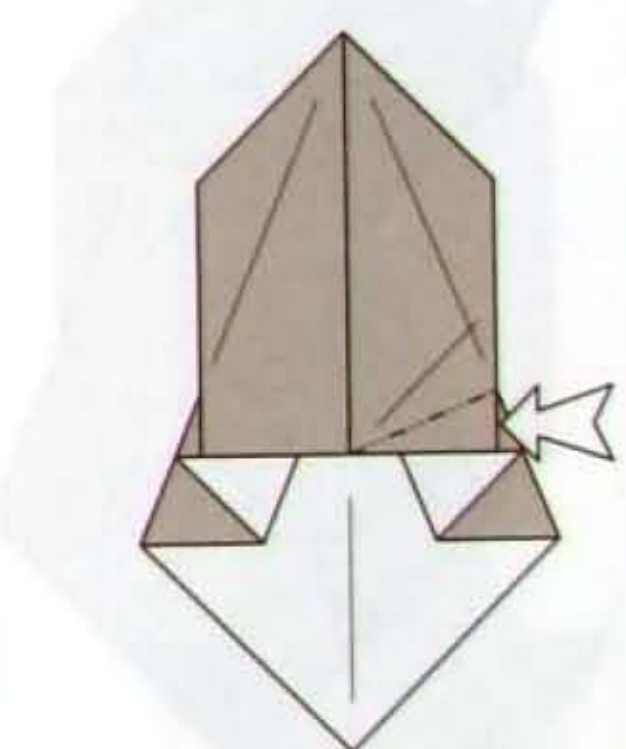

43. Inside reverse-fold.

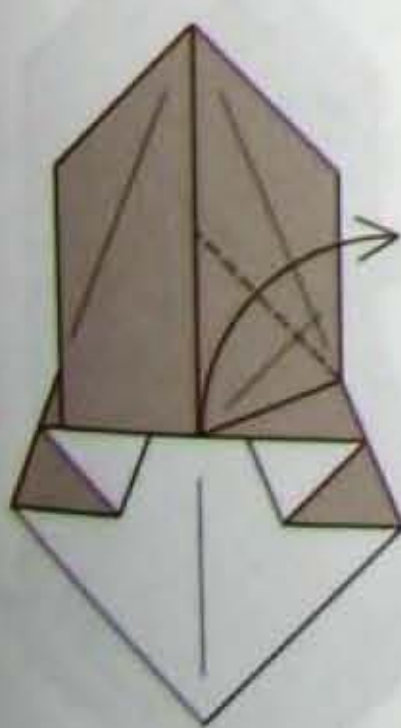

44. Valley-fold.

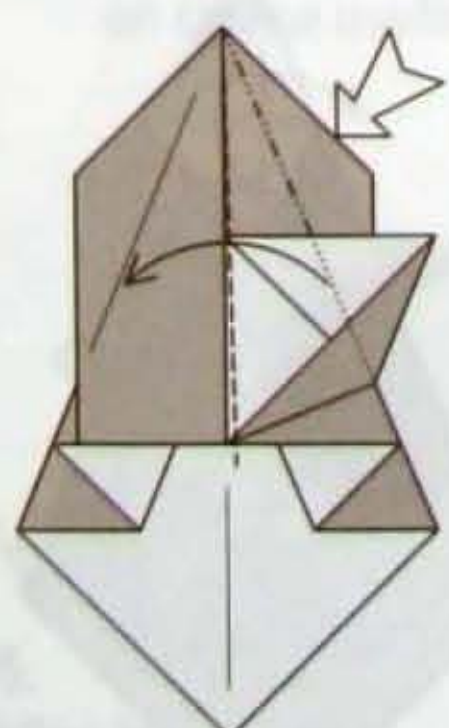

45. Squash-fold.

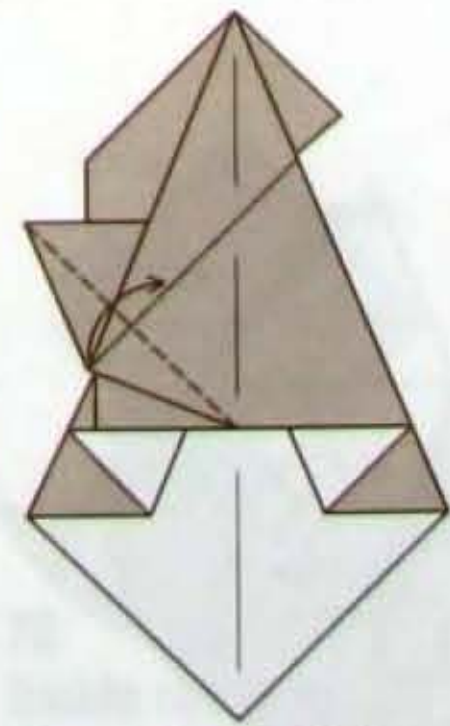

46. Valley-fold.

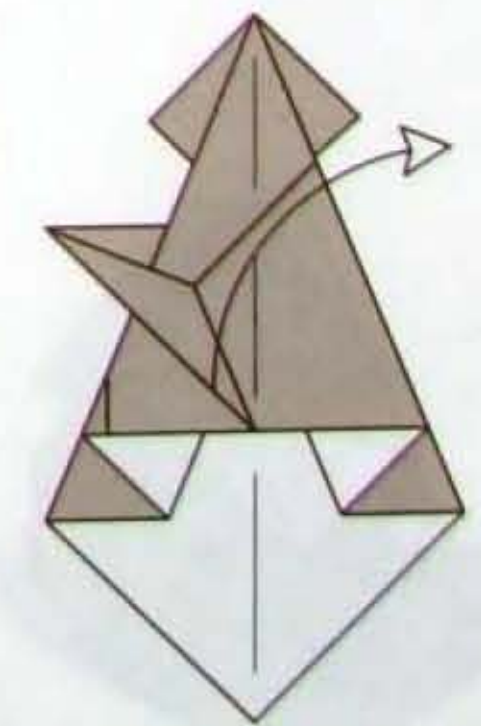

47. Unfold the entire layer to the right.

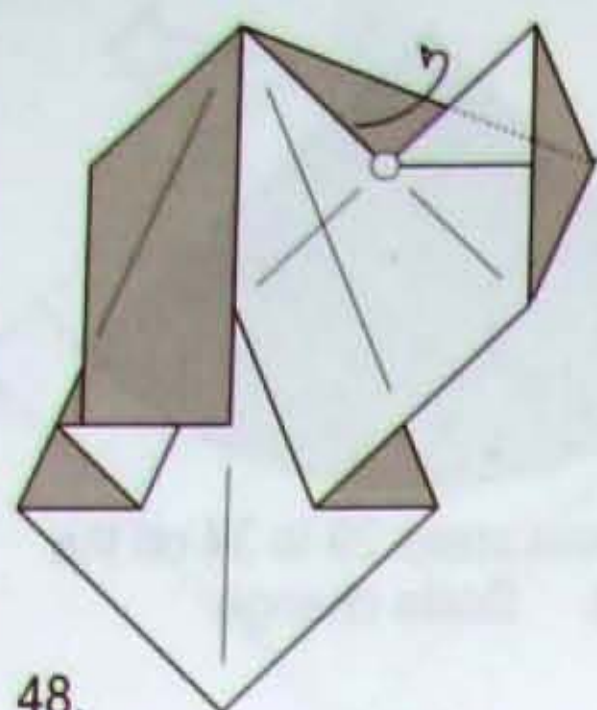

48. Place the indicated corner into the pocket behind it.

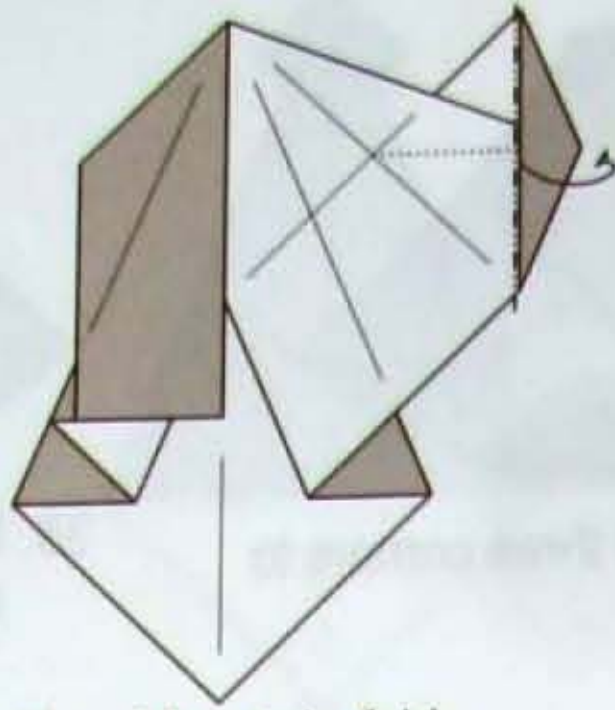

49. Mountain-fold.

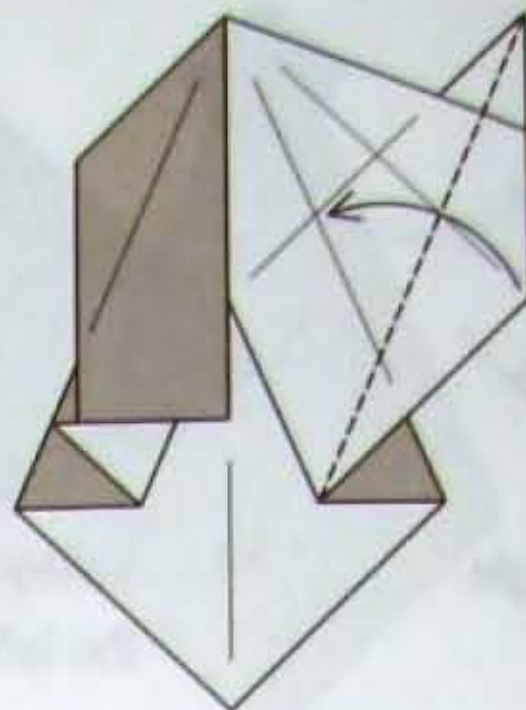

50. Valley-fold.

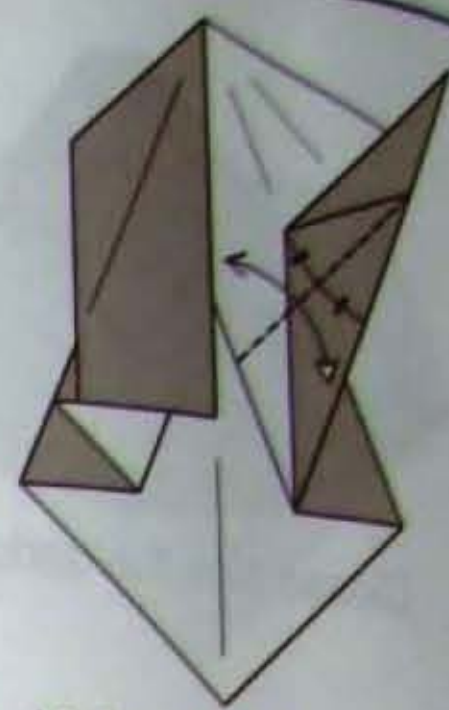

51. Valley-fold and unfold.

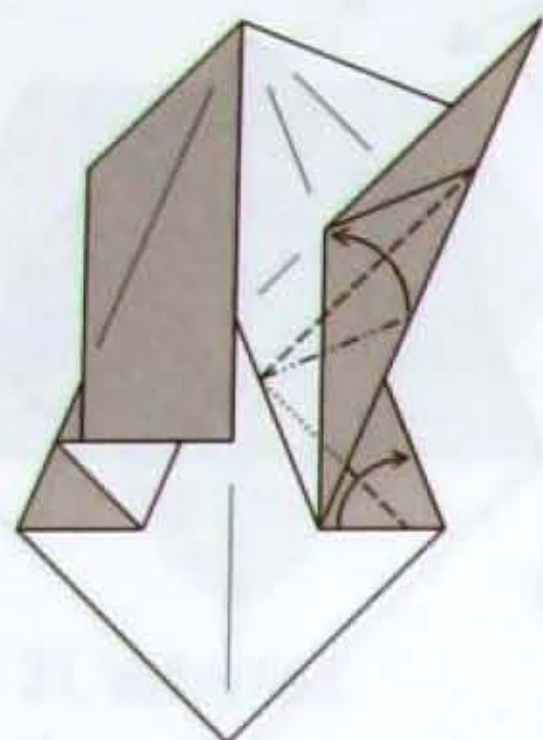

52. Swivel-fold.

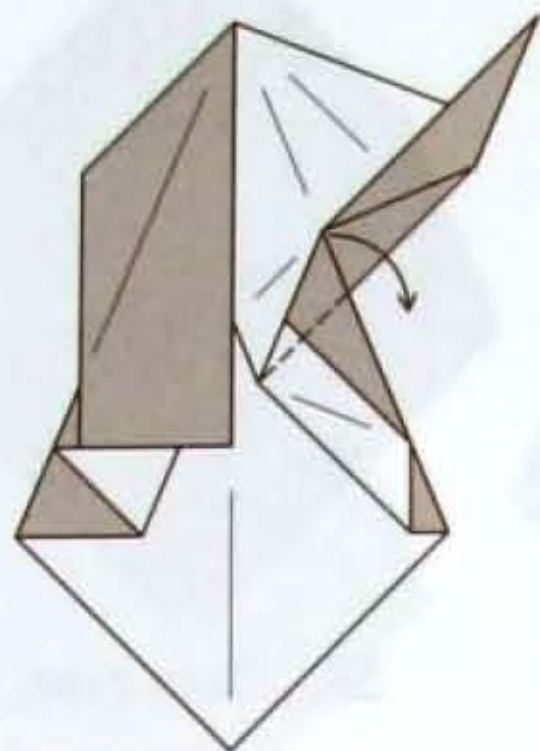

53. Valley-fold.

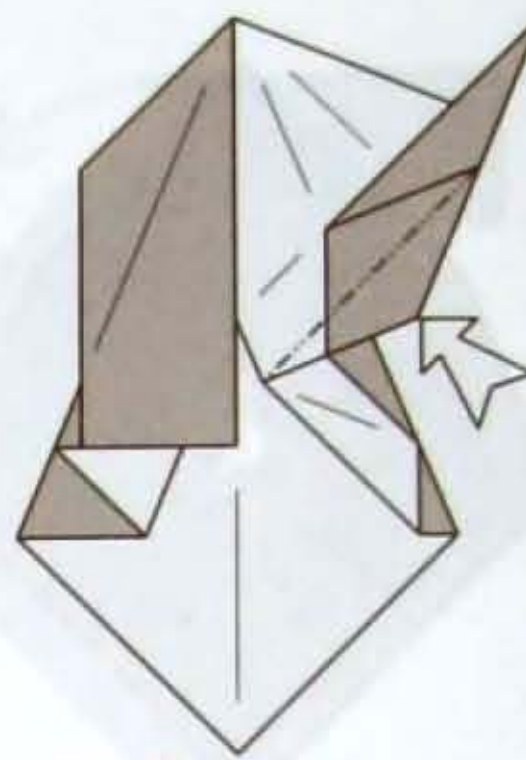

54. Closed-sink.

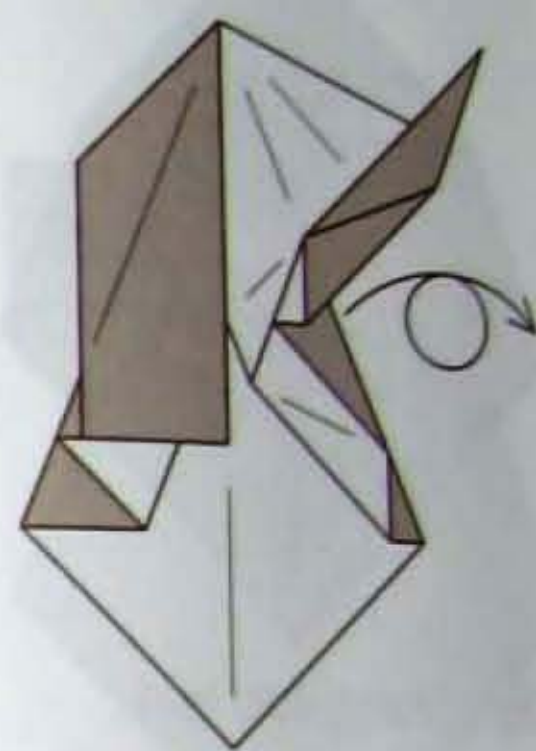

55. Turn over.

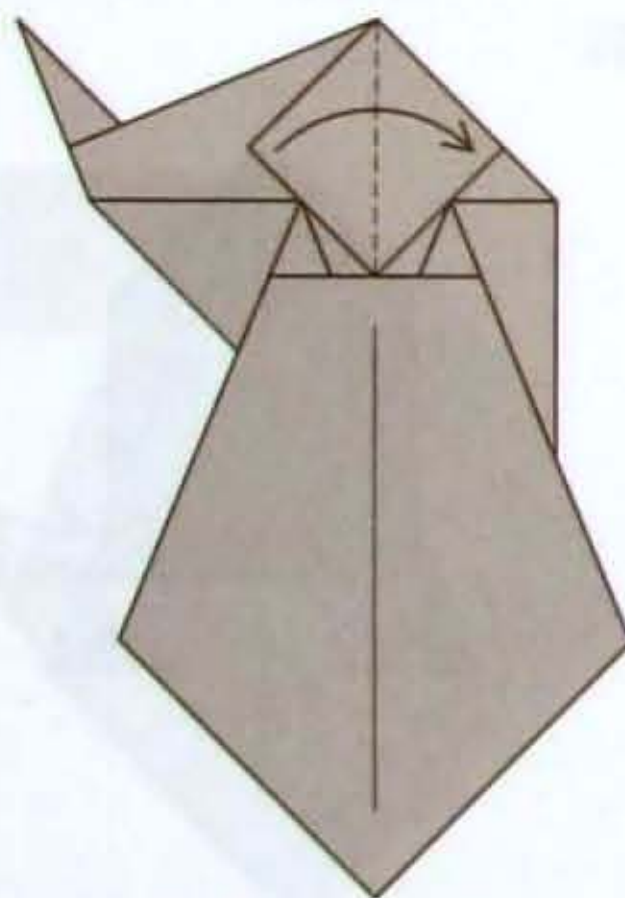

56. Valley-fold three corners to the right.

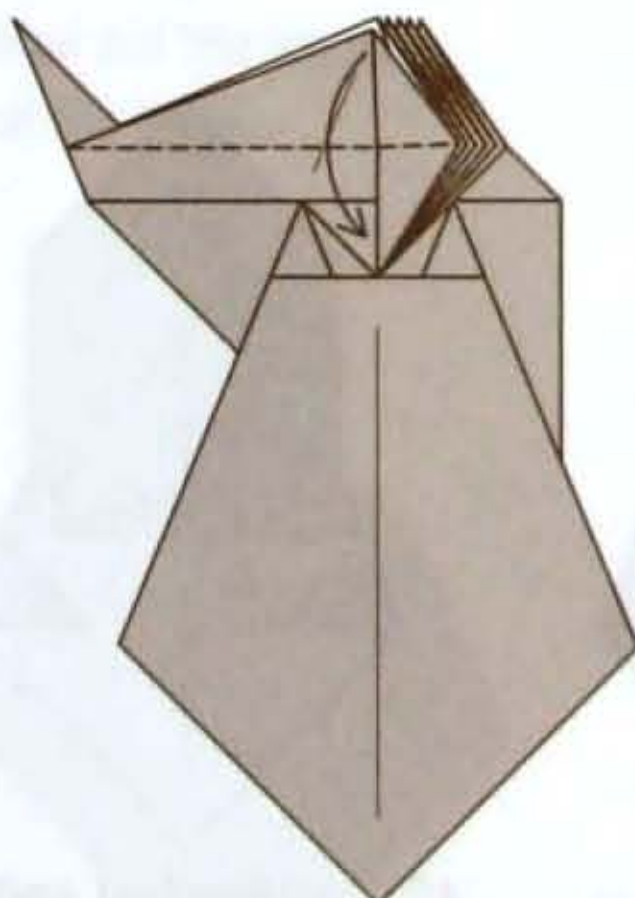

57. Valley-fold.

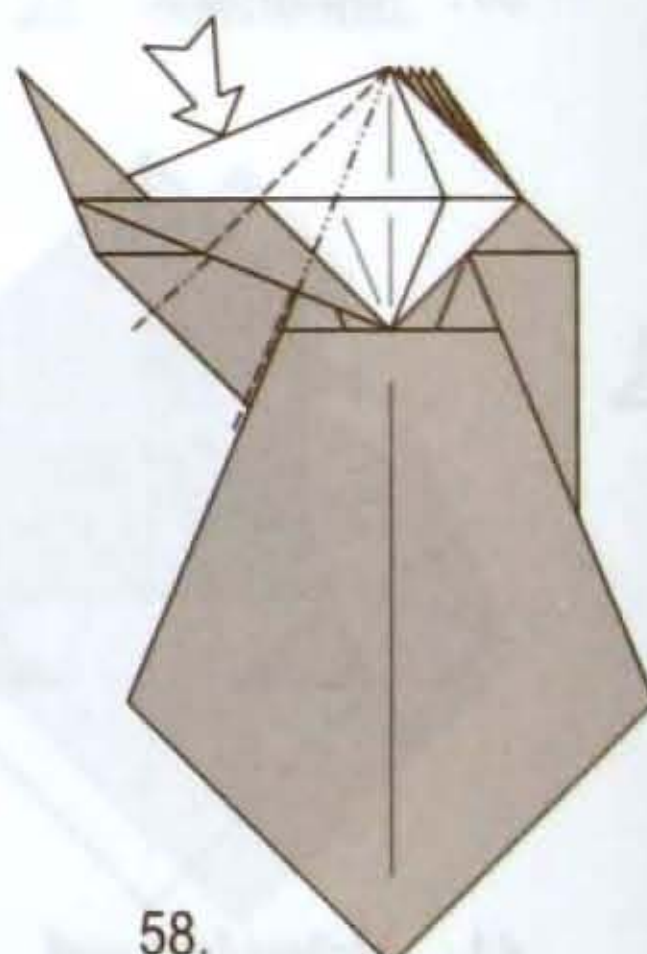

58. Reverse-fold in and out.

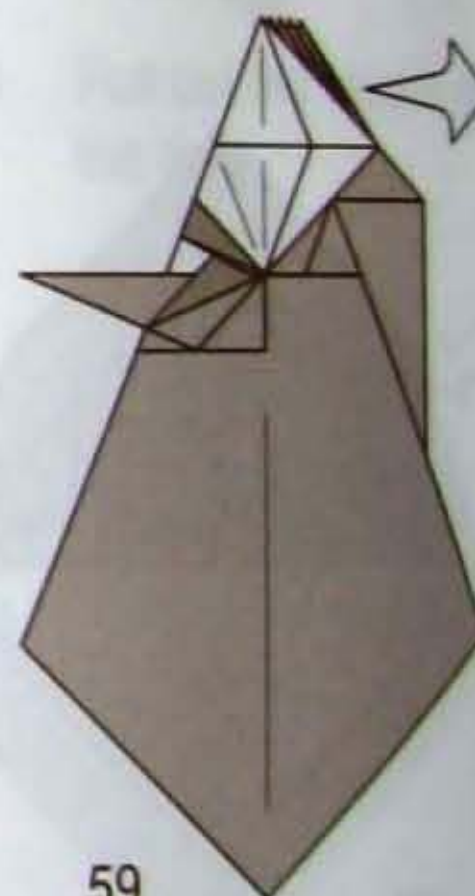

59. Wrap the layer around to color-change.

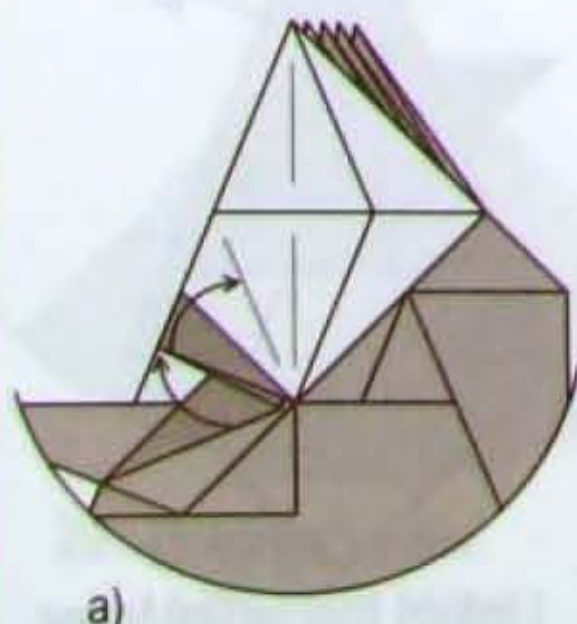

a)

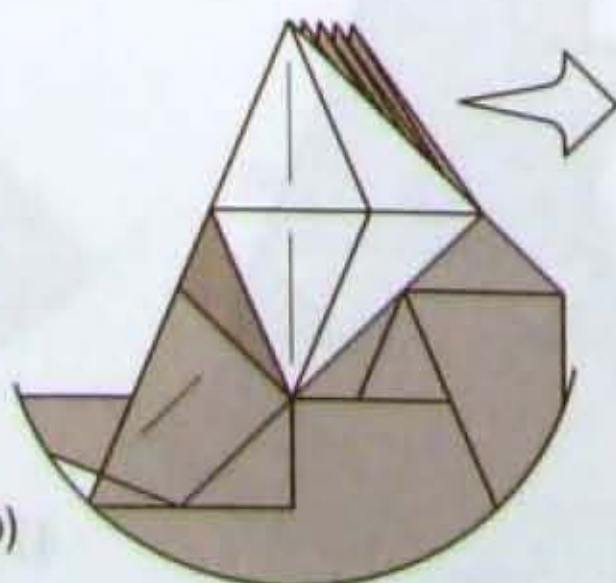

b)

60. Valley-fold three corners to the left.

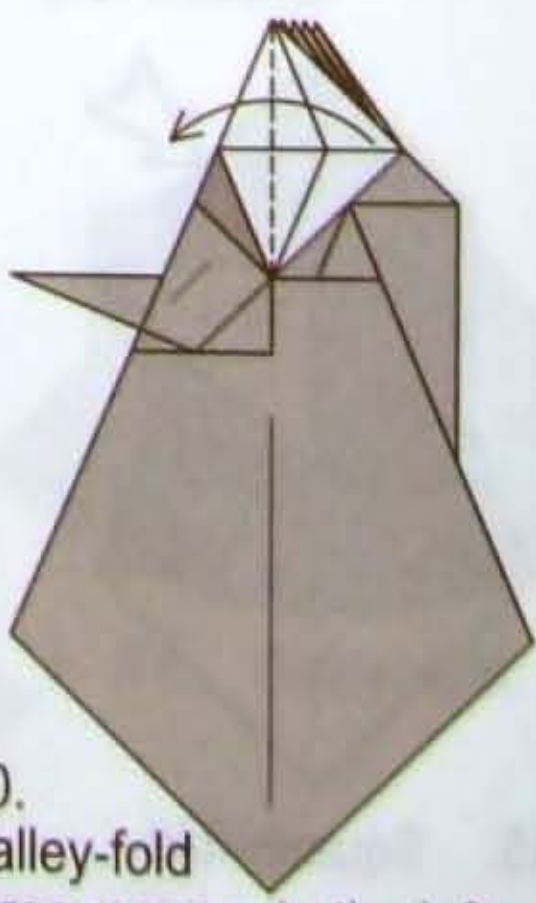

61. Place the darker layer on top.

62. Turn over.

63. Repeat steps 41 to 61 on the left.

64. Valley-fold.

65. Turn over.

66. Enlarge.

67. Valley-fold and unfold.

68. Stretch-fold.

69. Valley-fold and unfold.

70. Open-sink the central trapped layer on the crease made in step 69.

71. Open-sink the darker central trapped layer up on crease made in step 69.

72. Open-sink the point of step down again half-way. 71

73. The result.

74. Preliminary-fold.

75. Valley-fold the raw corner up.

76. Inside reverse-fold. See position next step.

77. Petal-fold. Repeat behind.

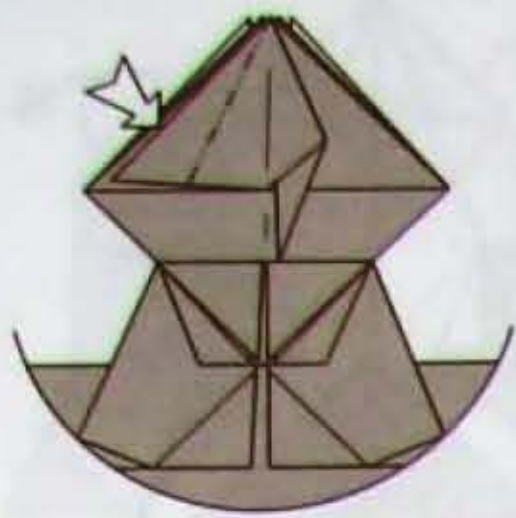

78. Repeat steps 76 to 77 on the left.

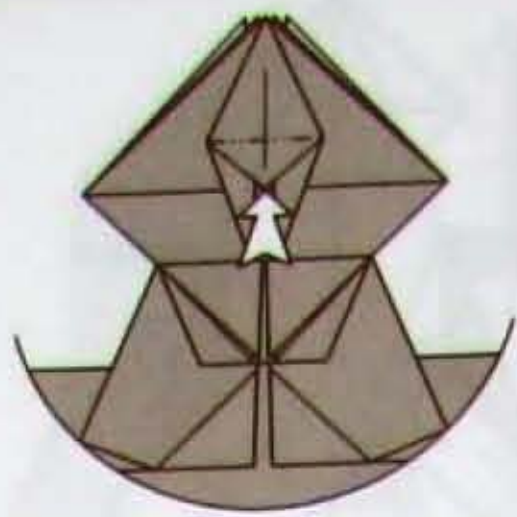

79. Inside reverse-fold.

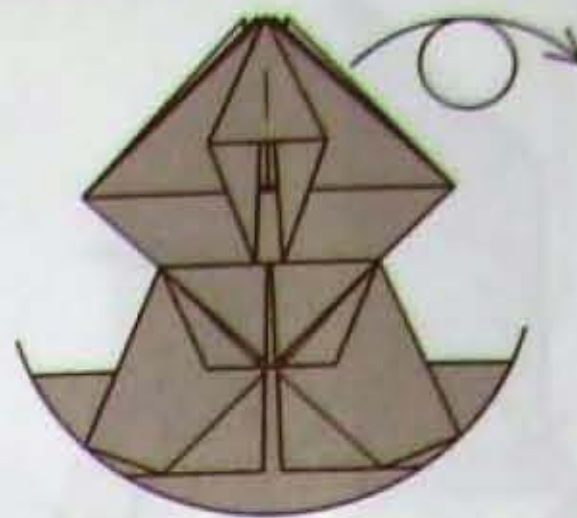

80. Turn over.

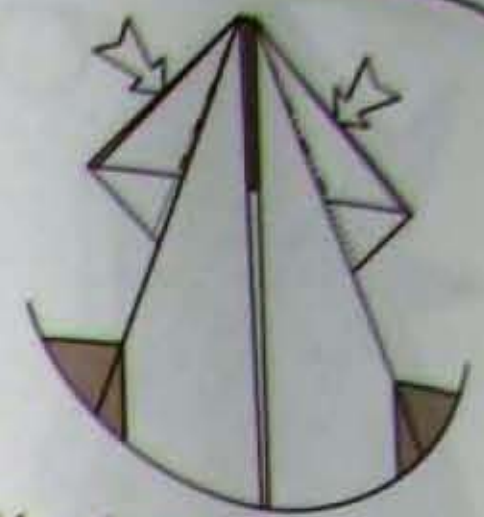

81. Inside reverse-folds.

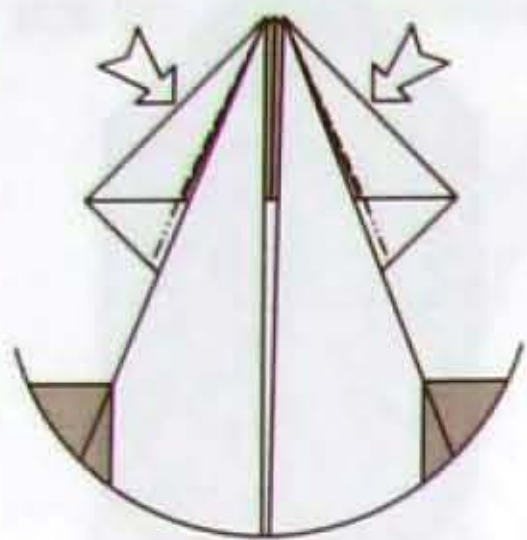

82. Inside reverse-folds.

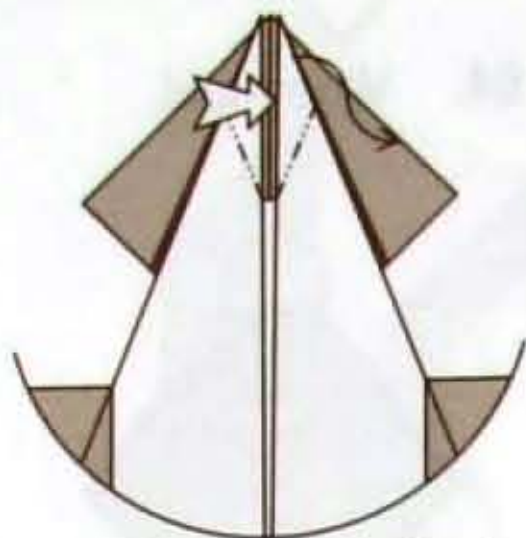

83. Inside reverse-fold. Repeat on the left.

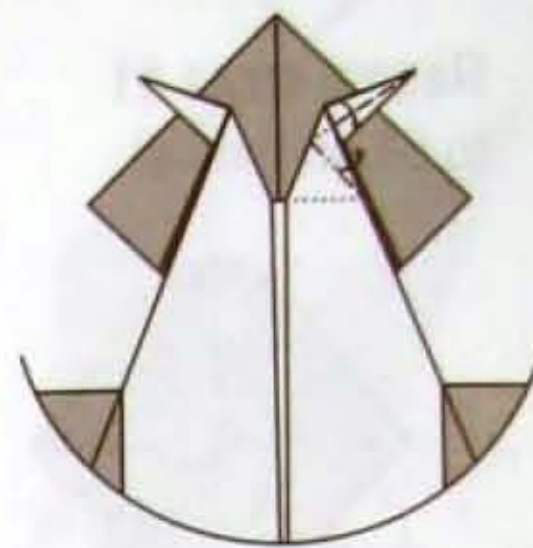

84. Swivel-fold. Repeat behind.

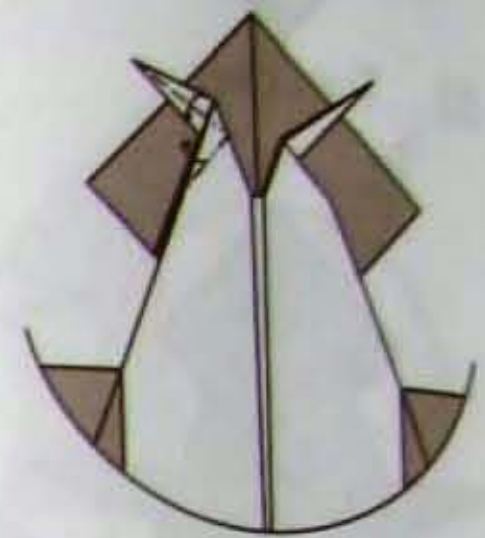

85. Repeat step 84 on the left.

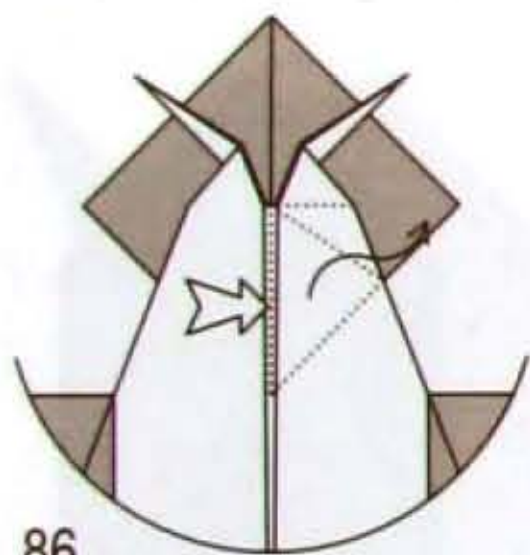

86. Reverse-fold the flap indicated by the X-Ray line.

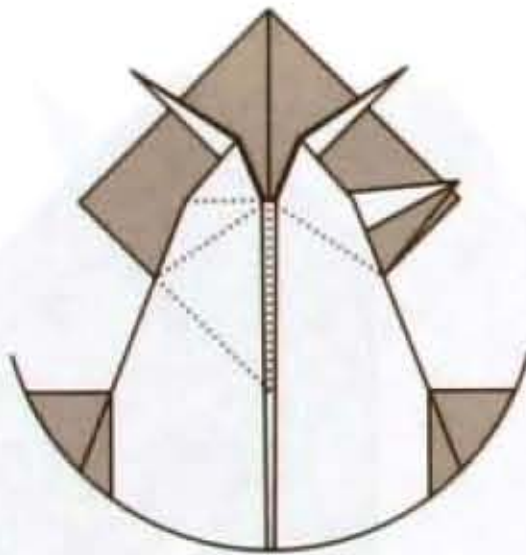

87. Like this. Repeat step 86 on the left.

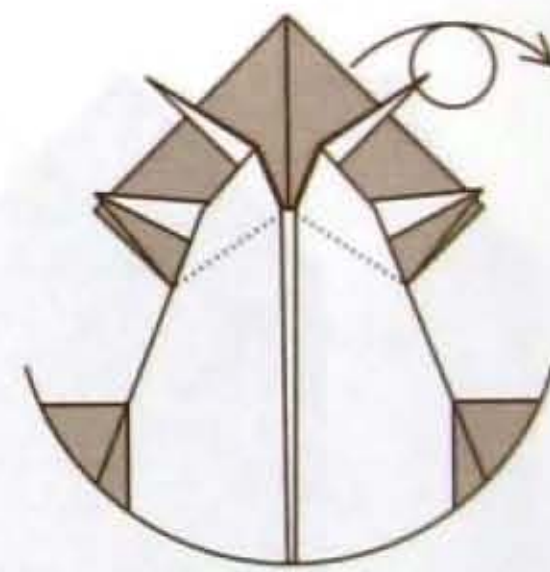

88. Turn over.

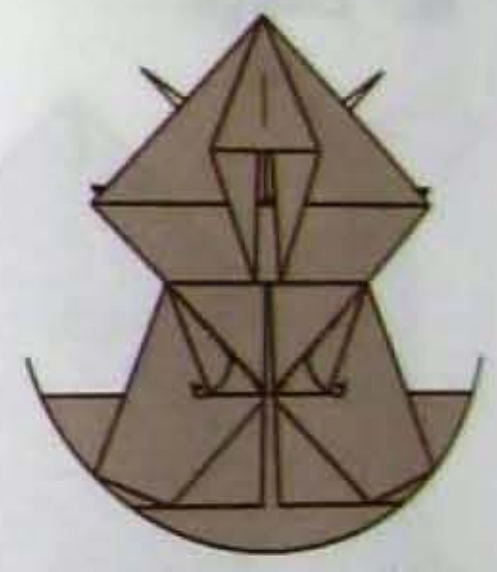

89. Mountain-folds.

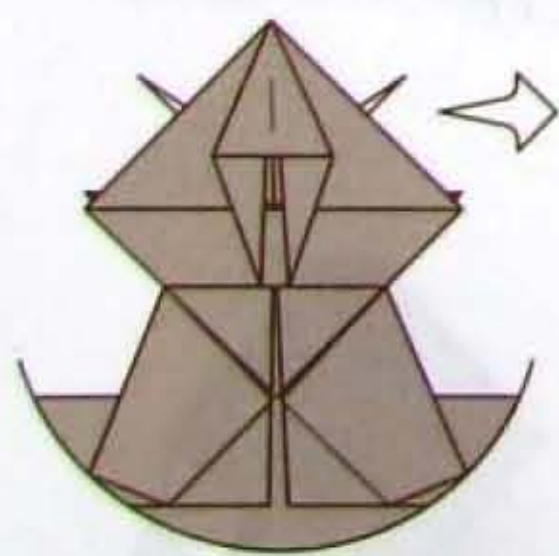

90. Scale change.

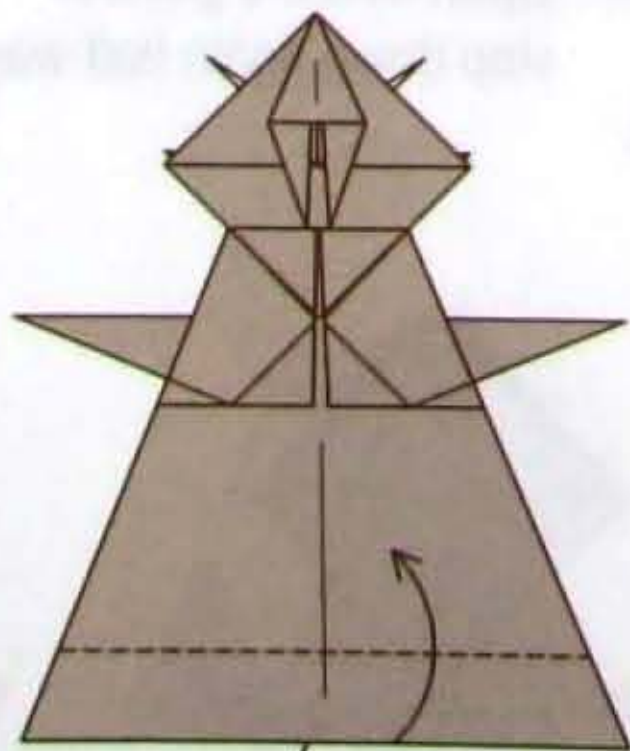

91. Pivot.

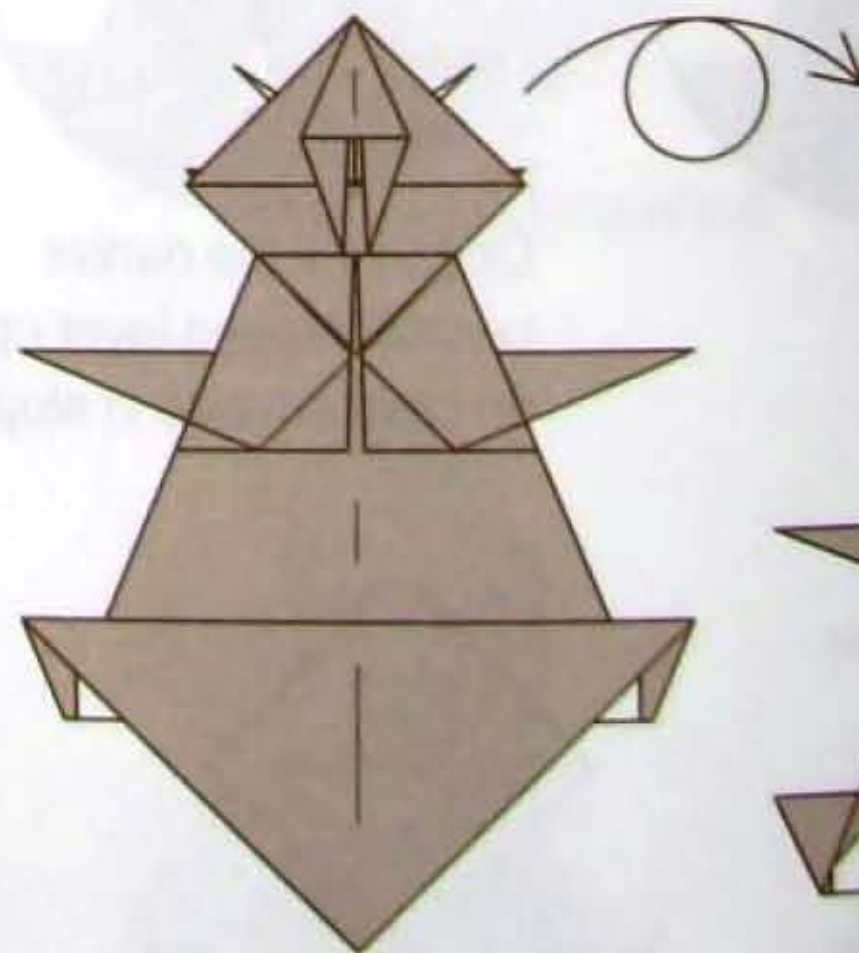

92. Turn over.

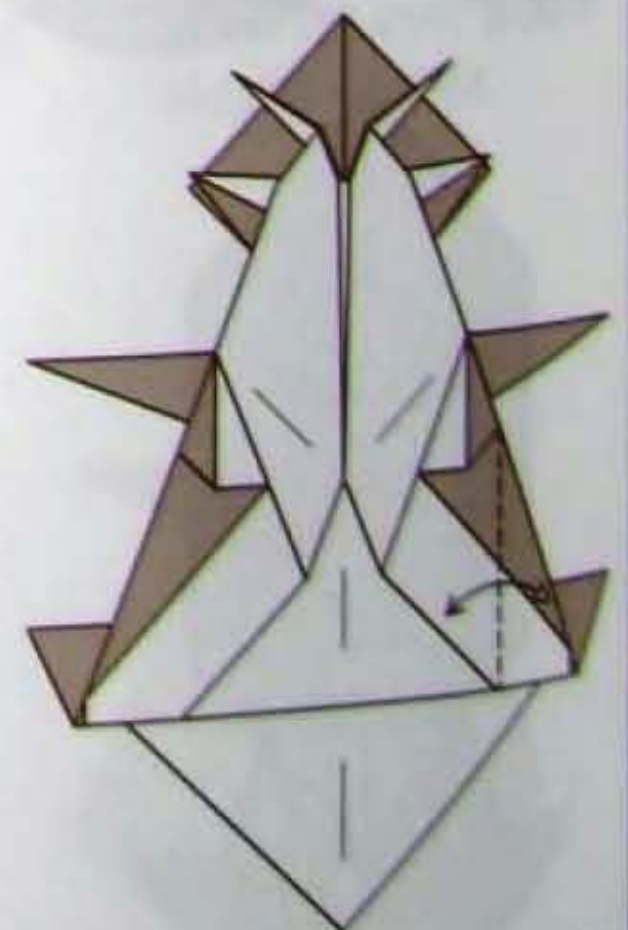

93. Valley-fold and unfold.

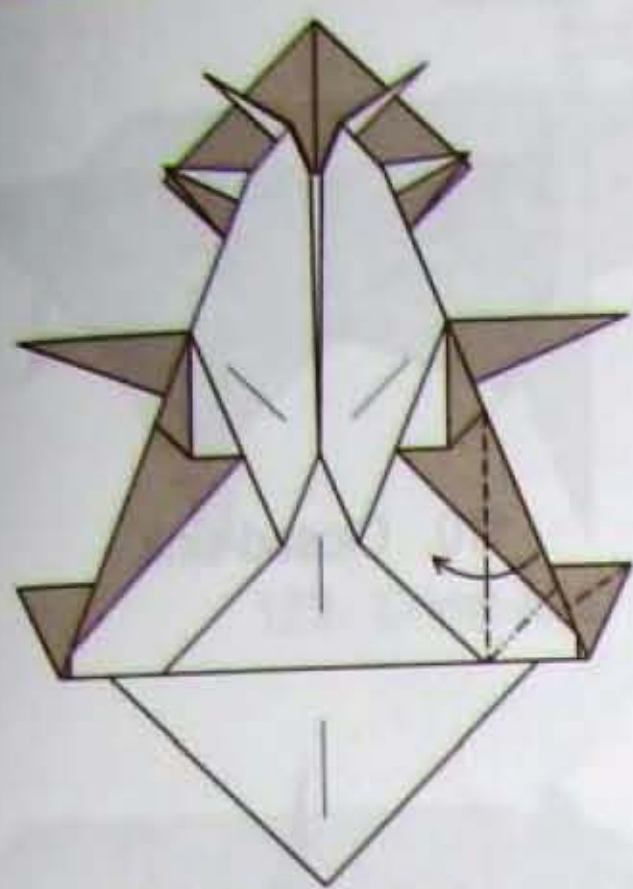

94. Swivel-fold.

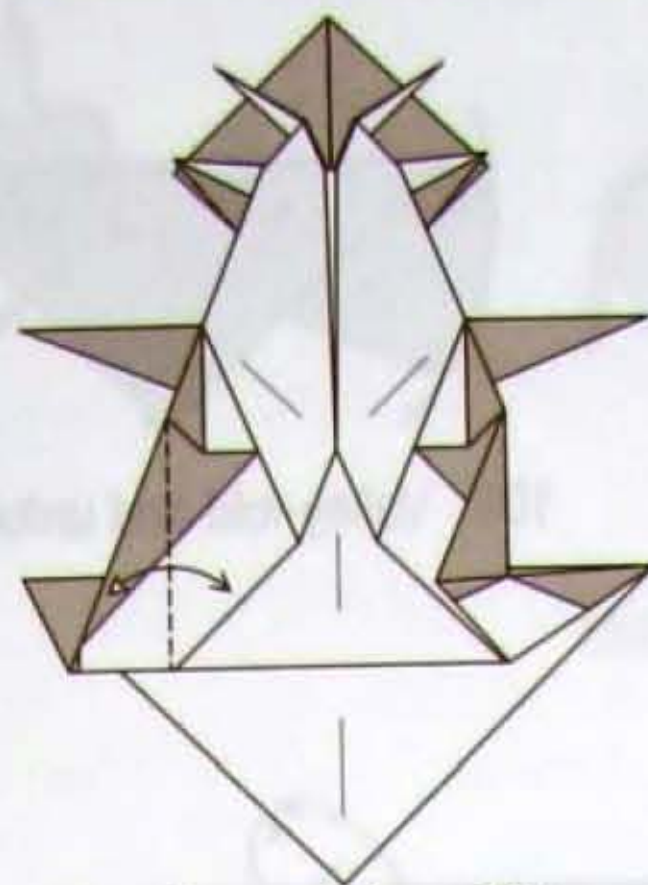

95. Repeat steps 93 to 94 on the left.

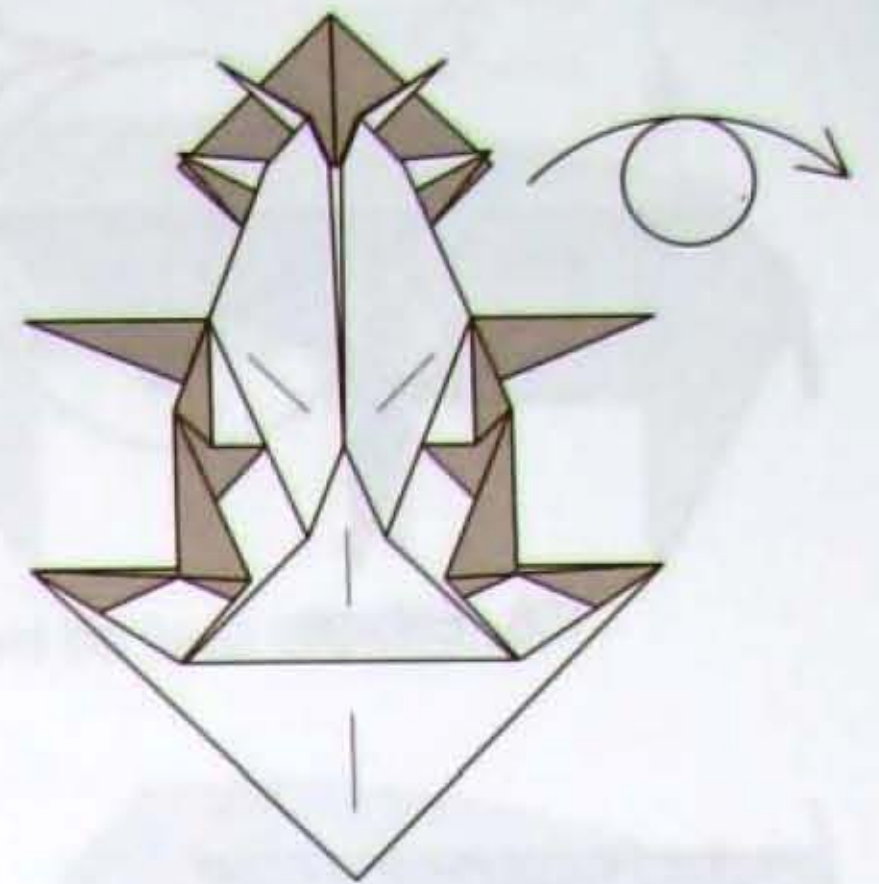

96. Turn over.

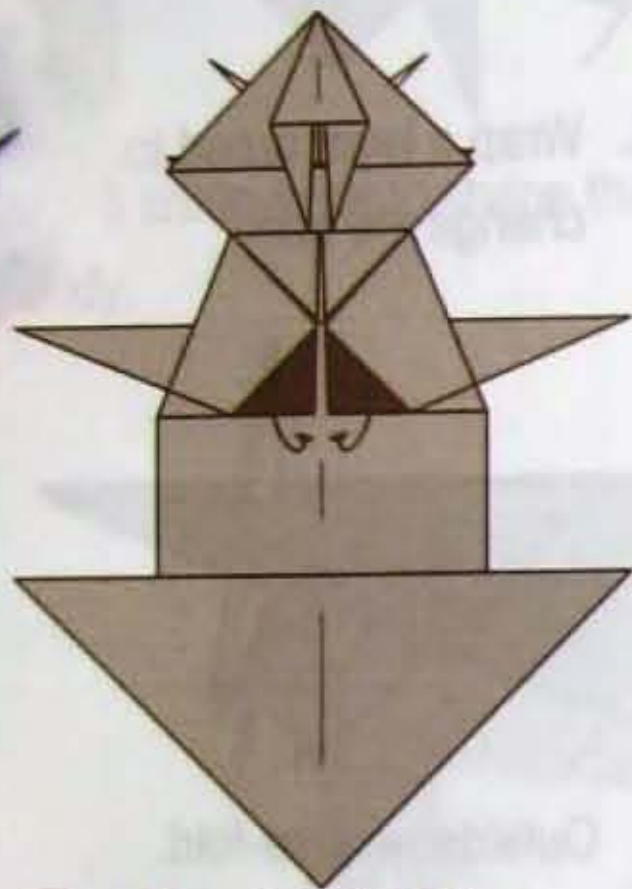

97. Mountain-fold the darker layers.

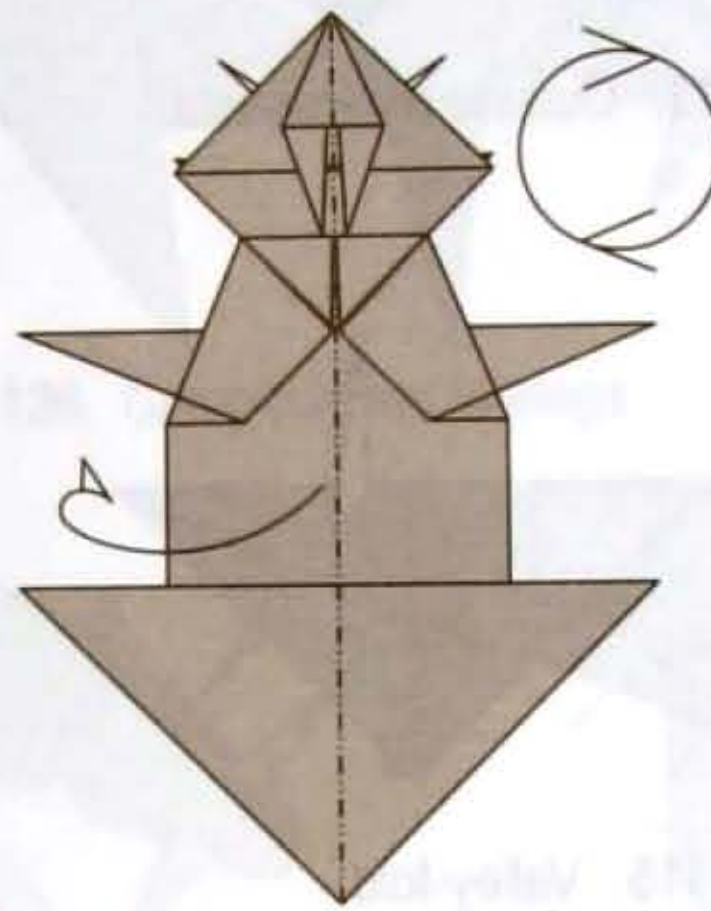

98. Mountain-fold in half and rotate.

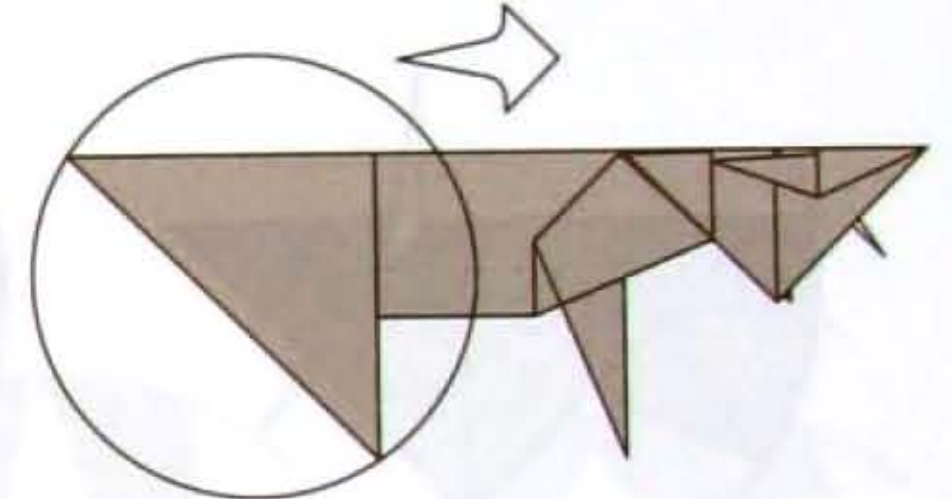

99. Enlarge.

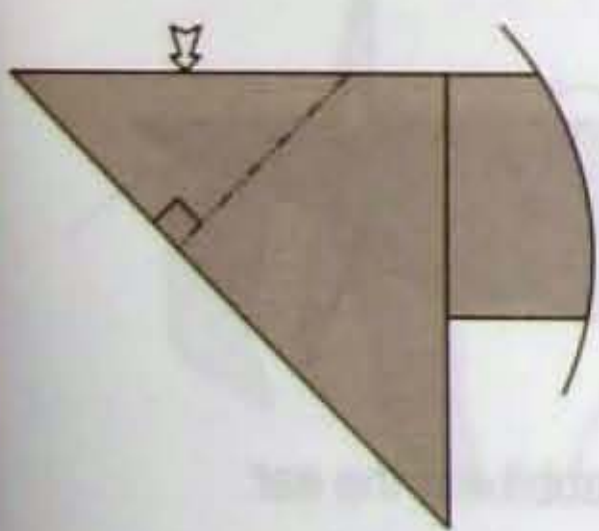

100. Inside reverse-fold.

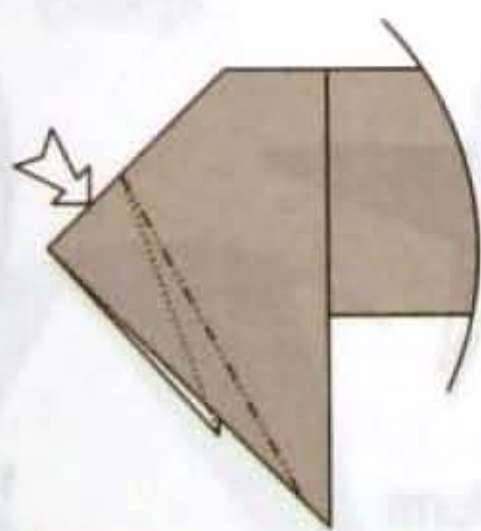

101. Inside reverse-fold. Repeat behind.

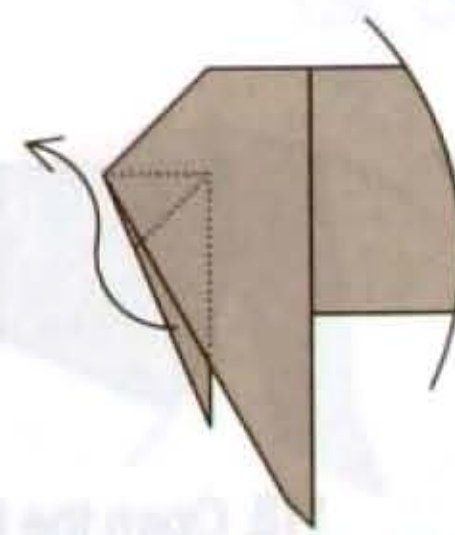

102. Reverse-fold the tail up.

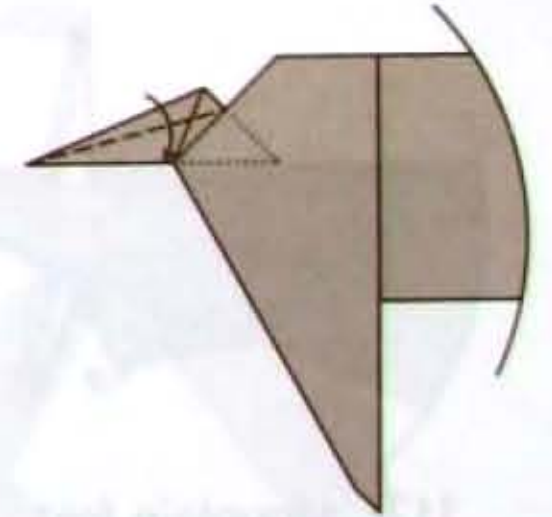

103. Inside reverse-fold. Repeat behind.



104. Mountain-fold. Repeat behind.

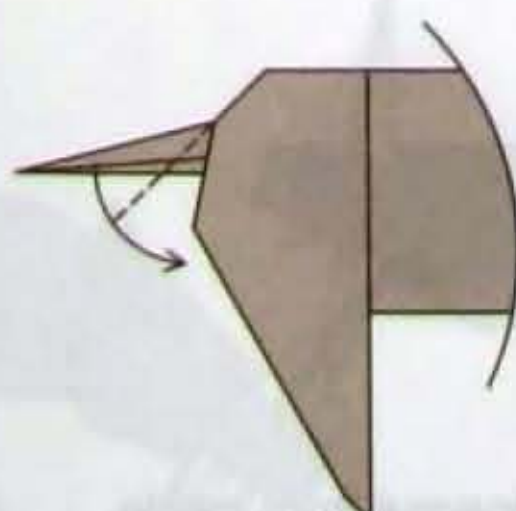

105. Outside reverse-fold.

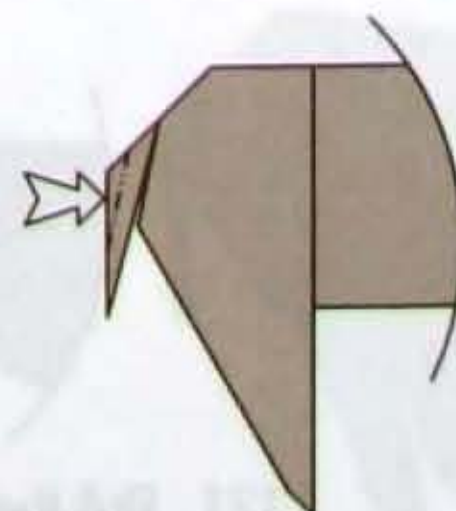

106. Open-sink.

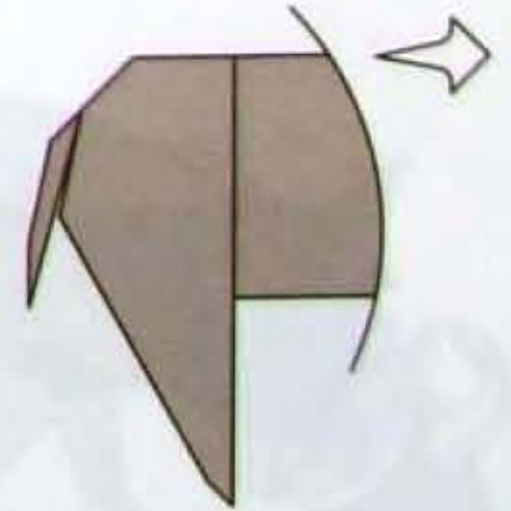

107. Scale change.

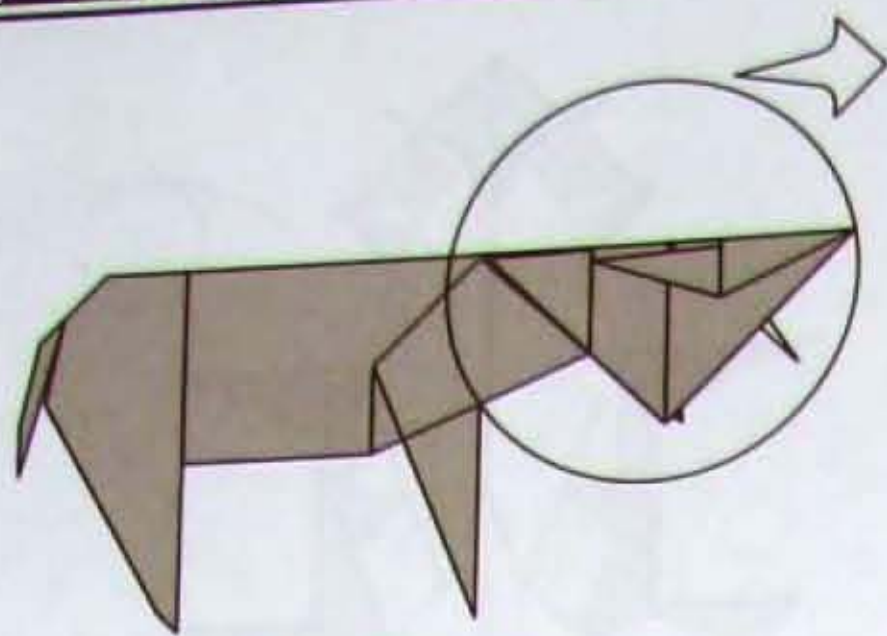

108. Enlarge.

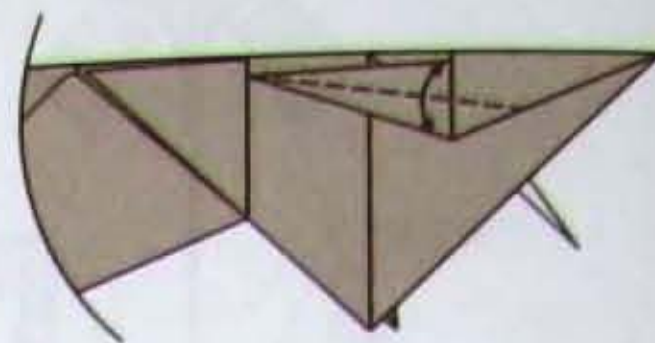

109. Valley-fold and unfold.

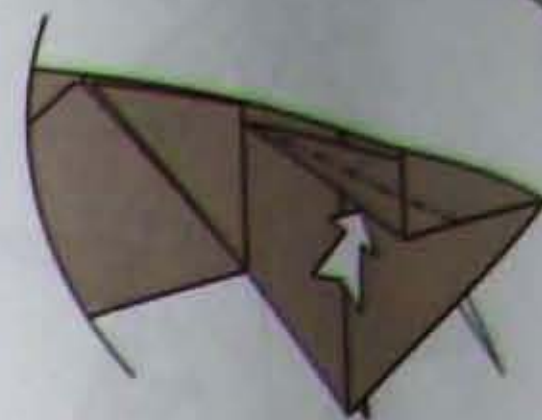

110. Closed-sink.

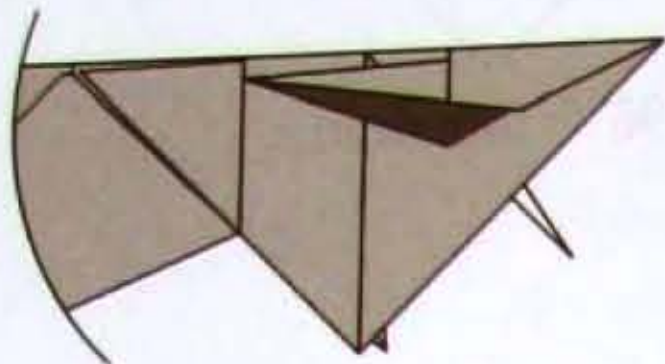

111. Open-sink the darker layer.

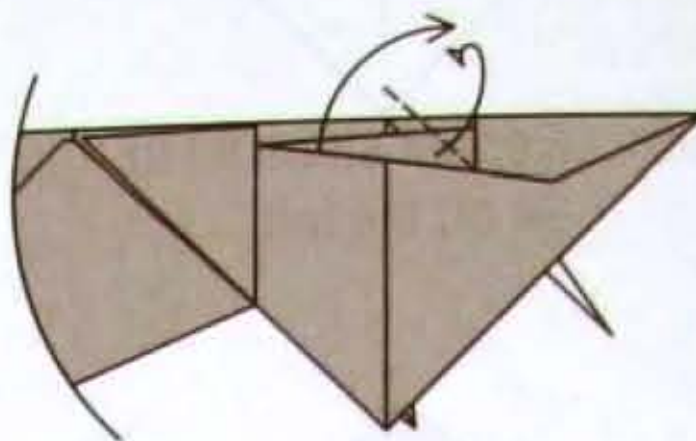

112. Outside reverse-fold.

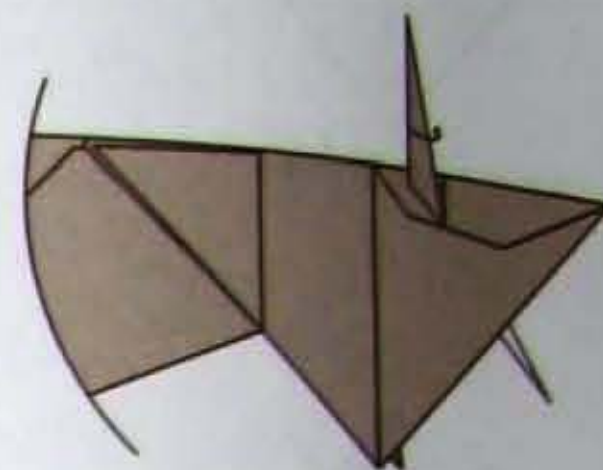

113. Wrap a layer around to color-change the tusk.

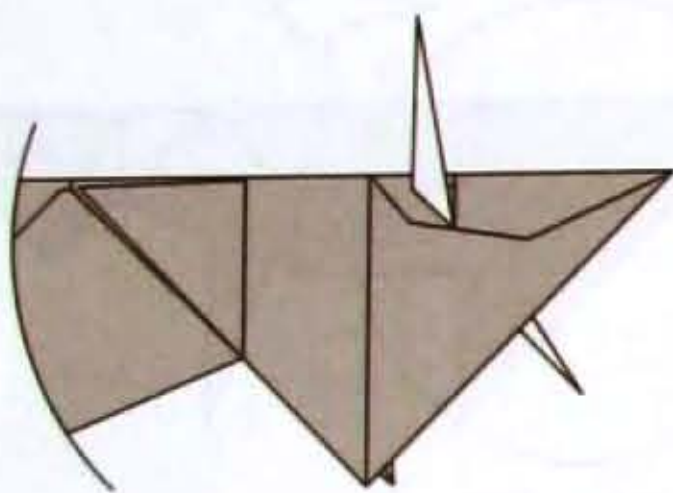

114. Repeat steps 109 to 113 behind.

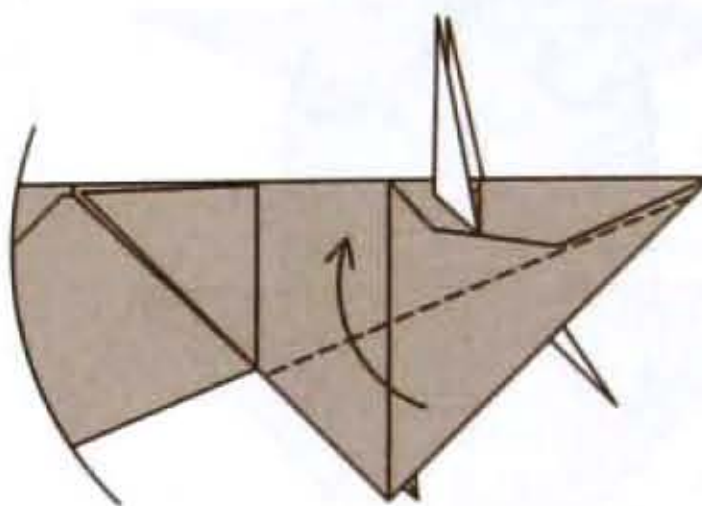

115. Valley-fold.
Repeat behind.

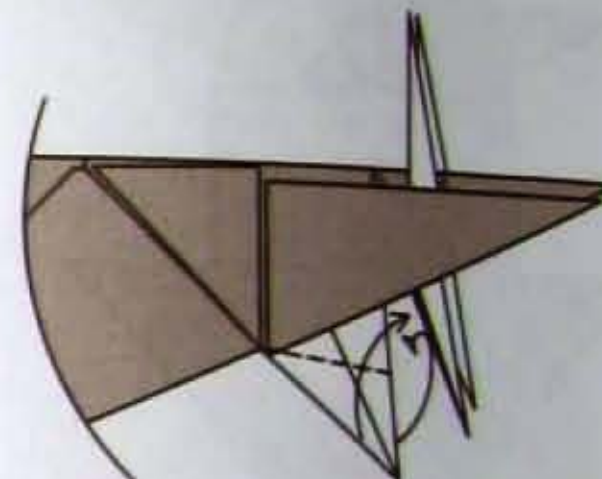

116. Outside reverse-fold.
Repeat behind.

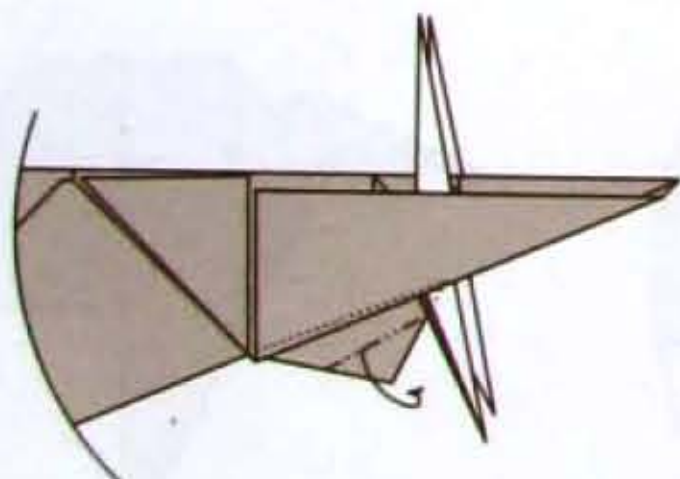

117. Mountain-fold.
Repeat behind.

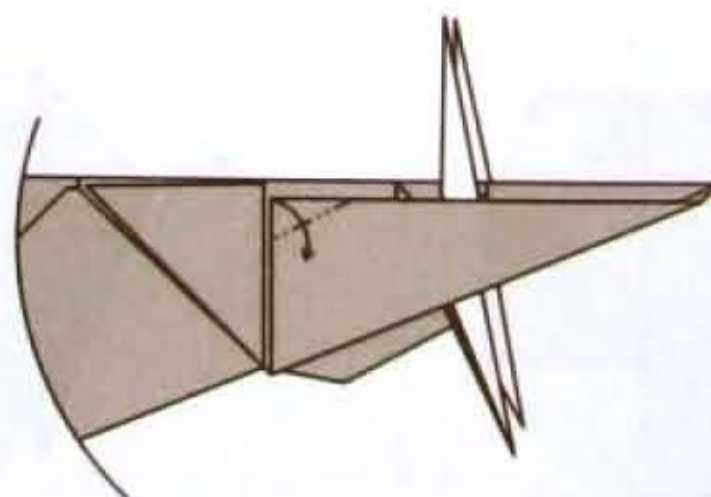

118. Open the layers to form the eye.
Repeat behind.

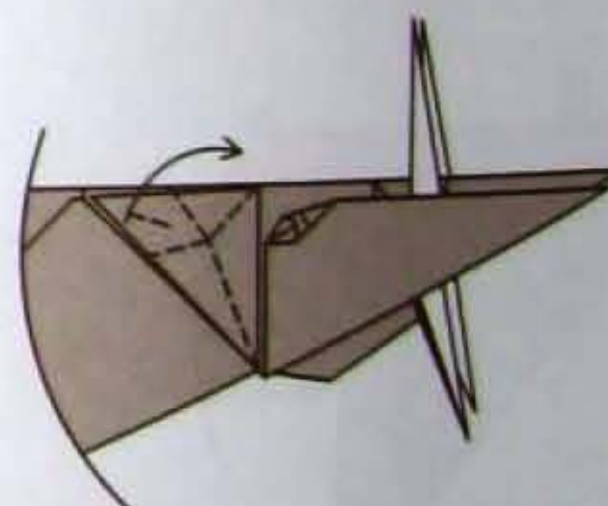

119. Rabbit-ear the ear.
Repeat behind.

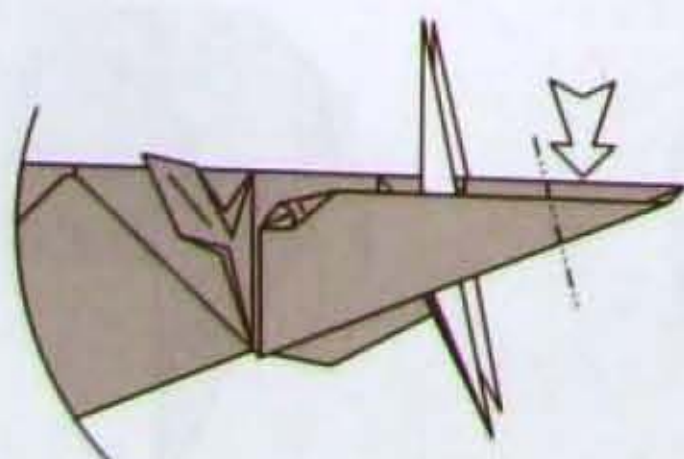

120. Inside reverse-fold.

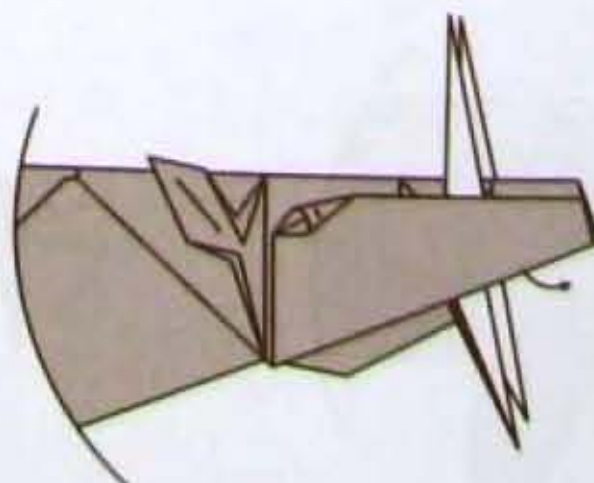

121. Pull the raw edge out from inside.
Repeat behind.

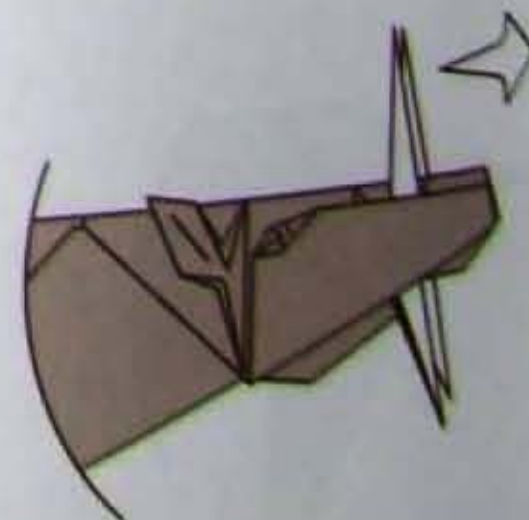

122. Scale change.

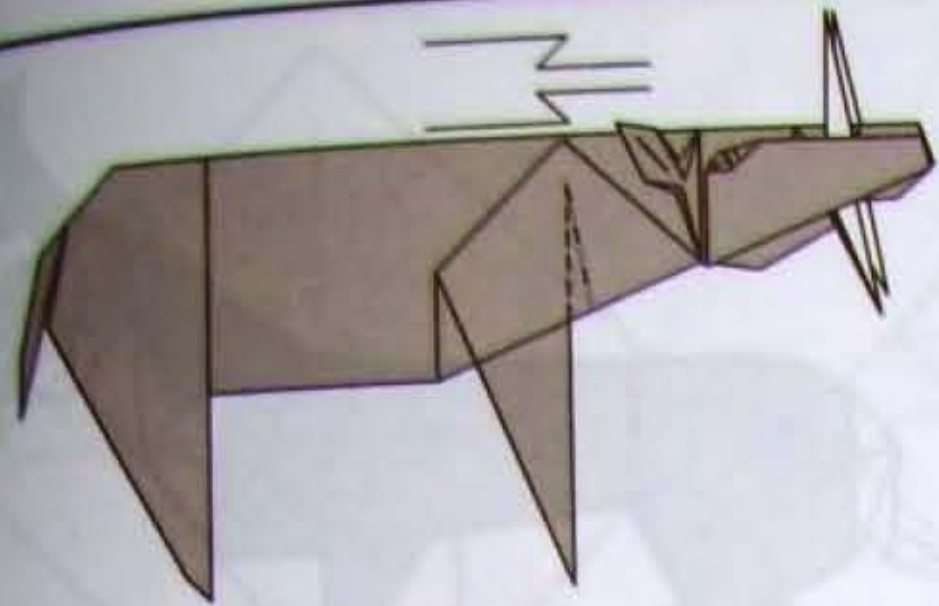

123. Crimp-fold.

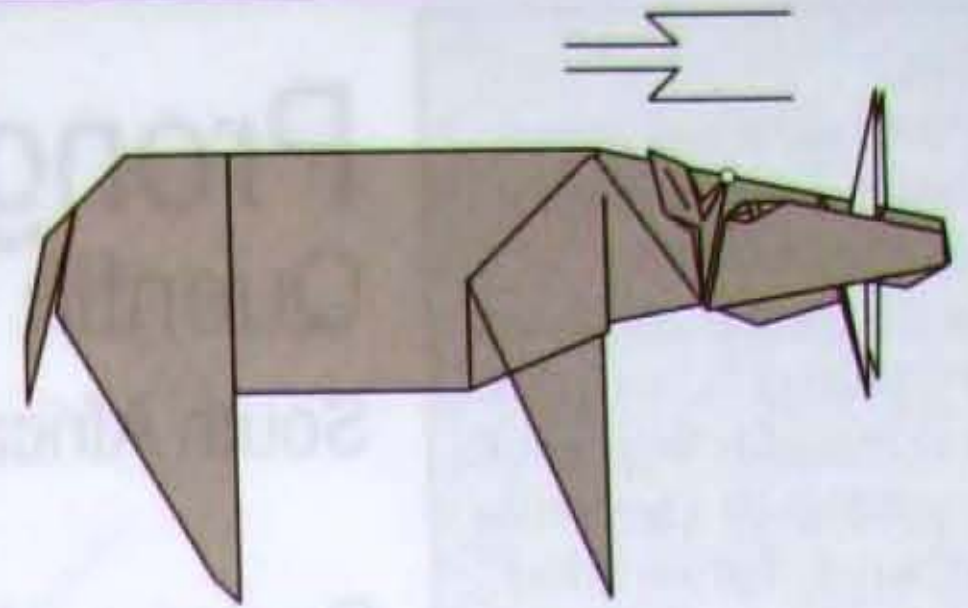

124. Pivot the head down further.

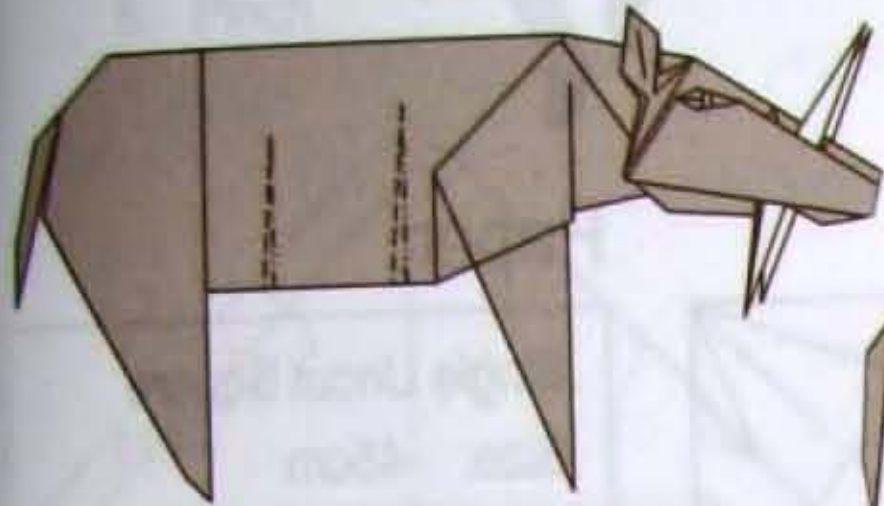

125. More crimp-folds to shape the body.

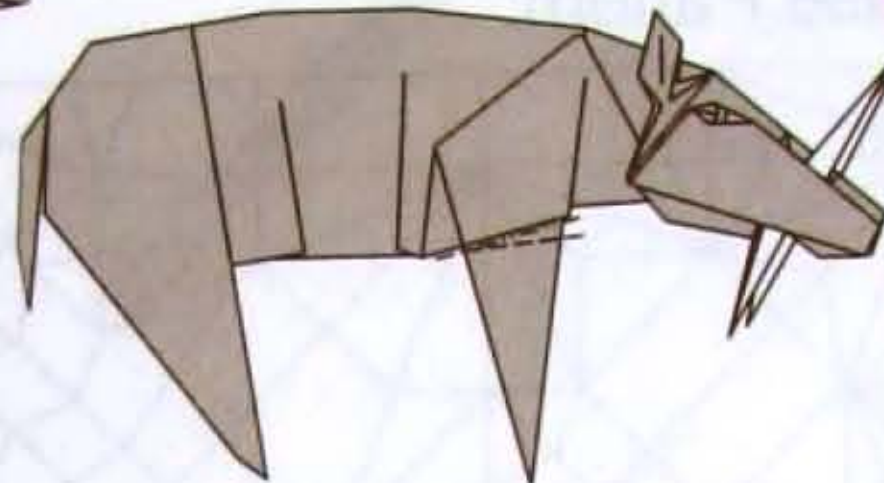

126. Crimp-fold the forelegs.

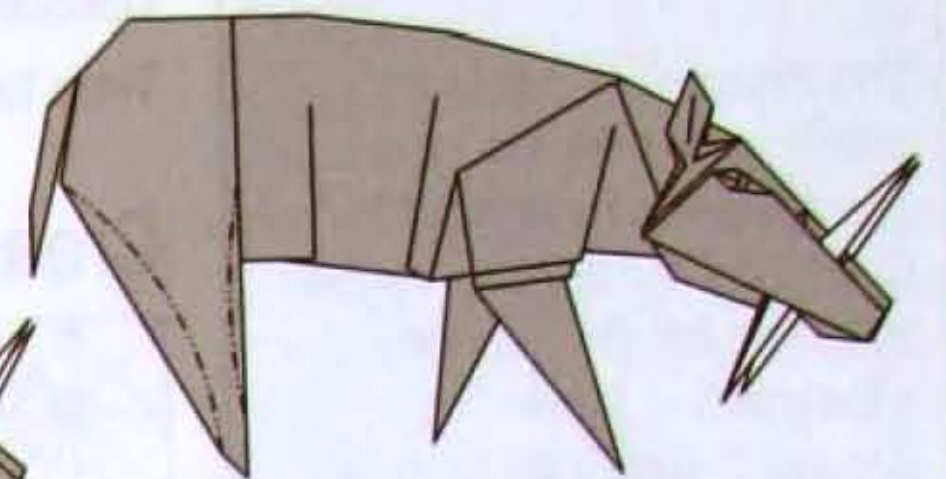

127. Shape the hind legs.



128. Enlarge.

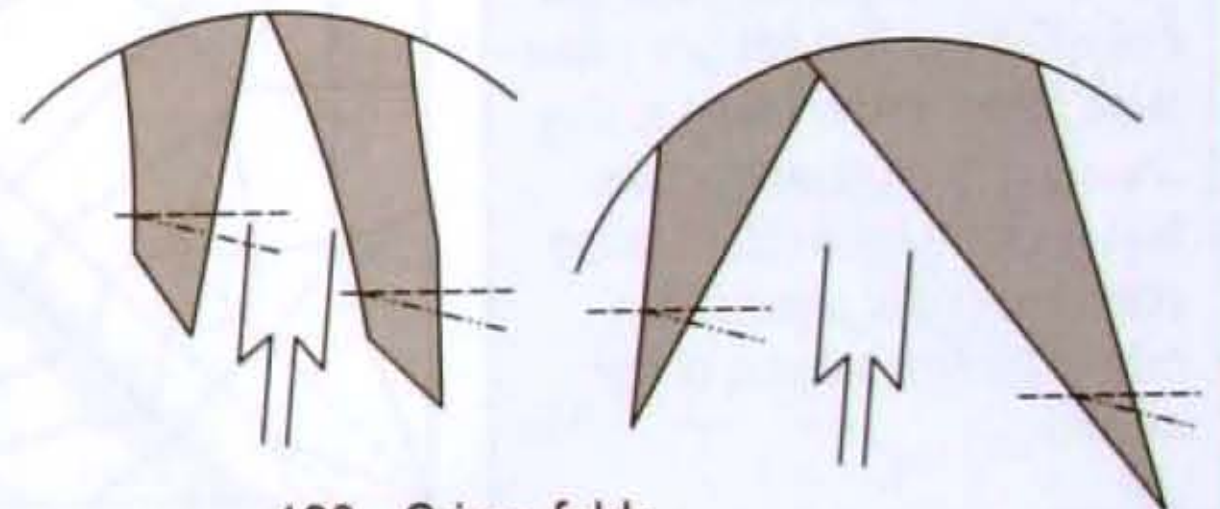

129. Crimp-folds.

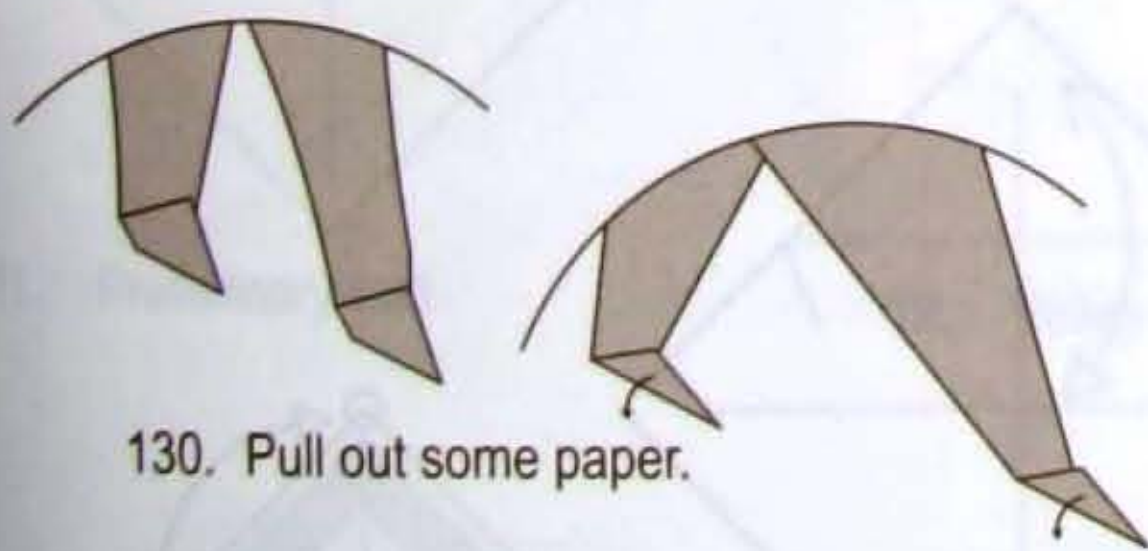

130. Pull out some paper.

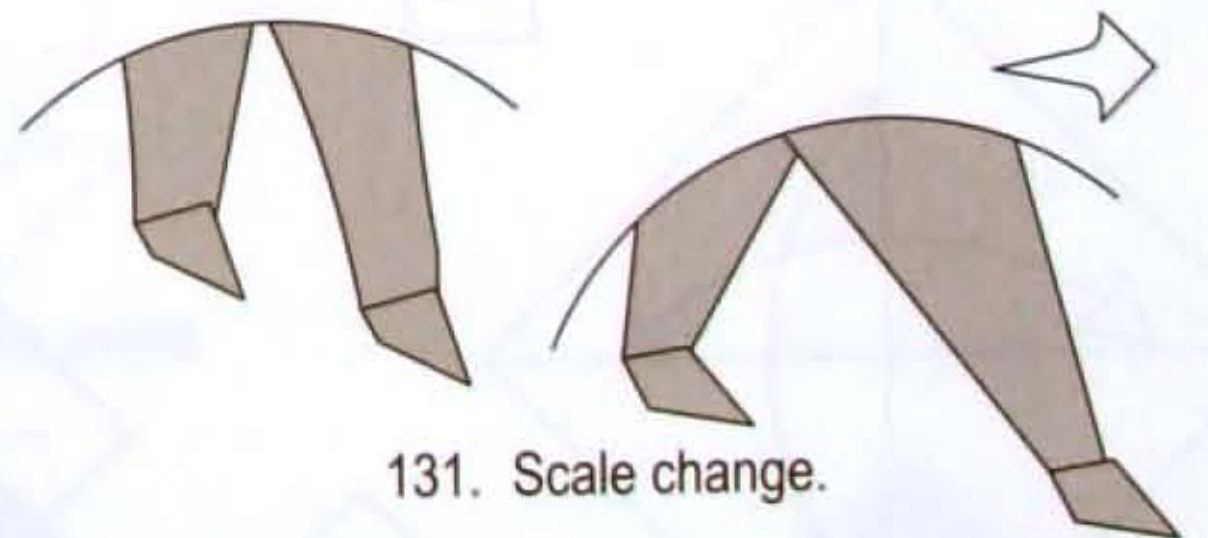

131. Scale change.

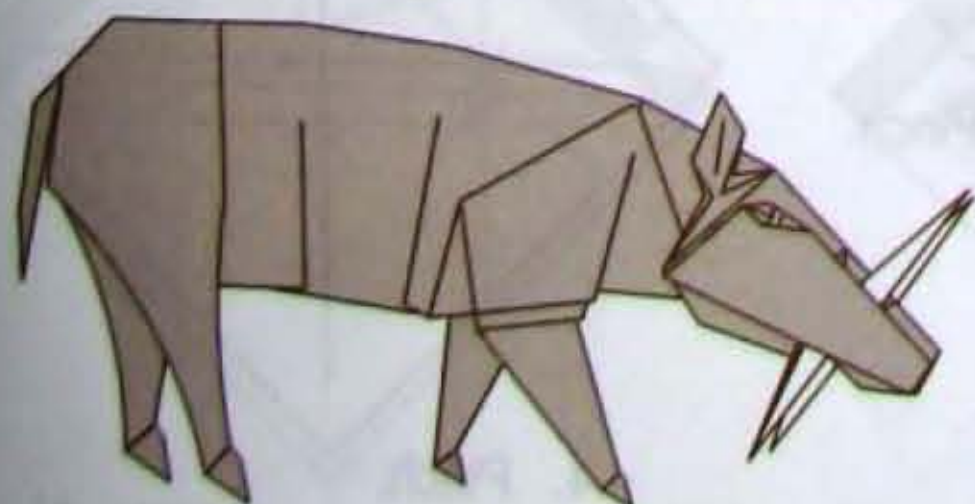

132. Curve the tusks.
Shape the body.

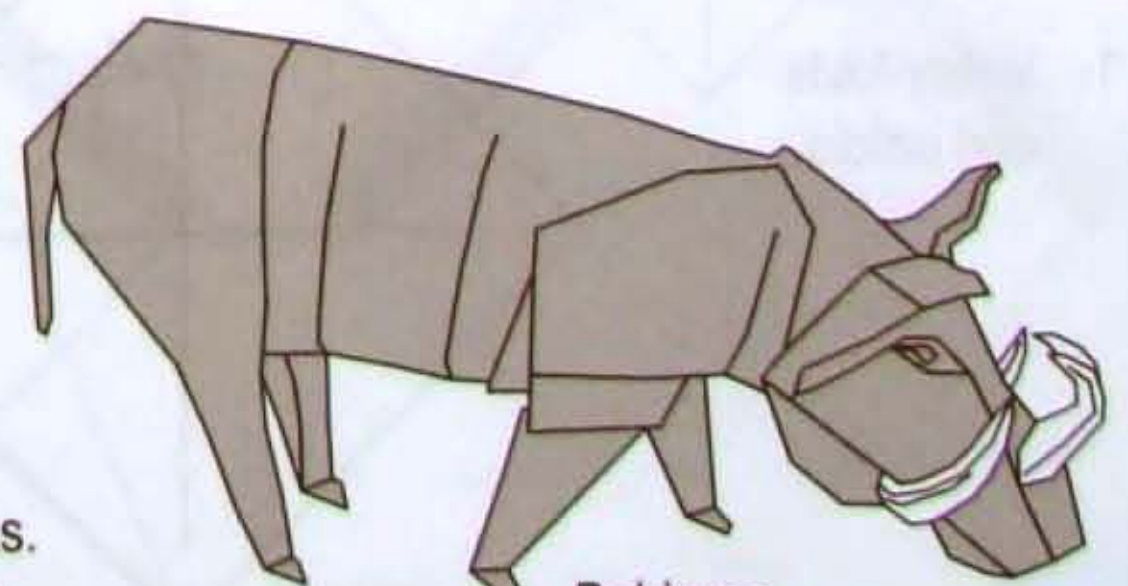

Babirusa.

Pronghorn
 The second fastest land animal, but the world champion over long distances, the Pronghorn antelope is a peculiar animal and the only species of its family. The horns are unusual as they consist of a horny sheath on a bony core (as in antelopes), but are forked and shed yearly (as a deer's antlers). It is named after the "prong" on its horns.

This design came about after a challenge by Mike Van Horne. The difficult part was actually doing the white colour-changed stripes on the neck. I added an edge graft that serves the purpose of adding the prong to the horn, as well as lengthen the front legs. You can see this in the structure of the cp.

I suggest using a very thin paper to achieve well-shaped horns and also to minimise the thickness of the colour-changed layers on the body. For your first attempt, use a large paper! You will have to play around with the shaping of the legs to give the animal a running pose. Looking at pictures can help in the final shaping of the model.

Pronghorn

Quentin Trollip

South Africa / Canada

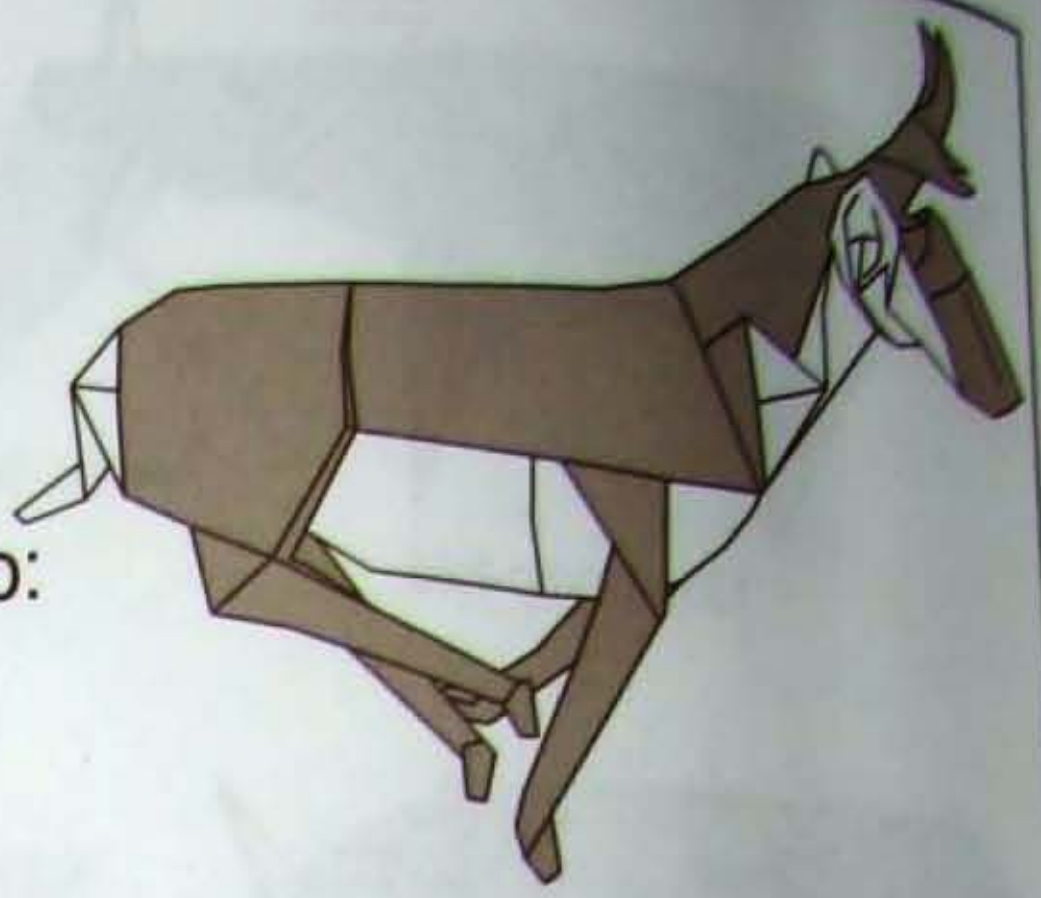

Design and diagram info:
 Date: 11 July 2010
 Difficulty: Complex
 Time to fold: 2 Hours

Crease Pattern:

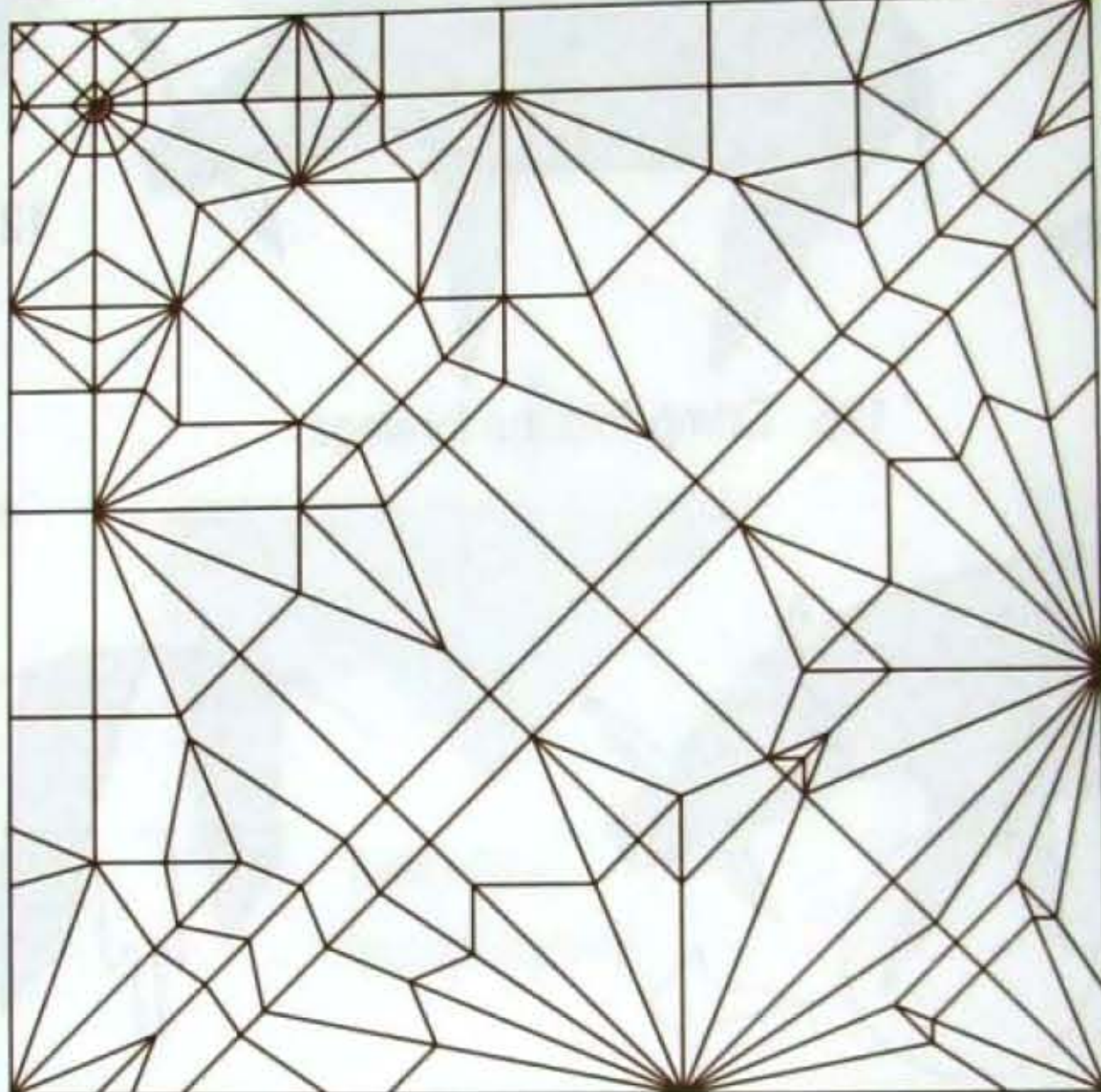

Paper:

Single Uncut Square	
Size: 45cm	
Color: White-Brown	
Type: Kami	No
Foil	Ok
Wet-Fold	Best

Ratio: 0.42 Length

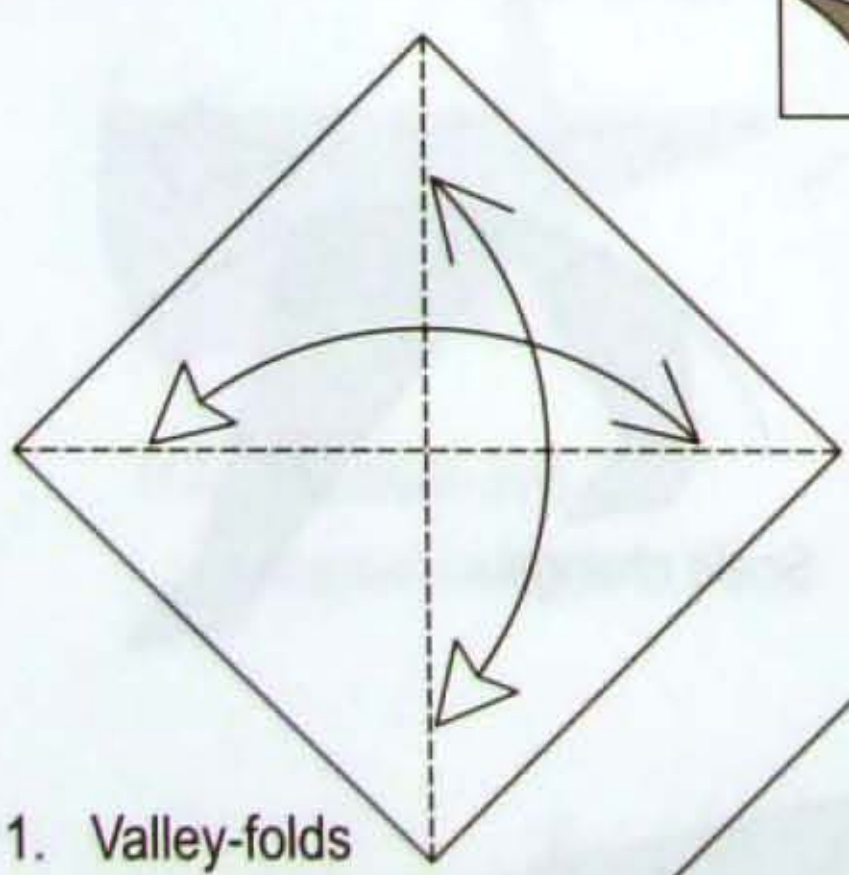
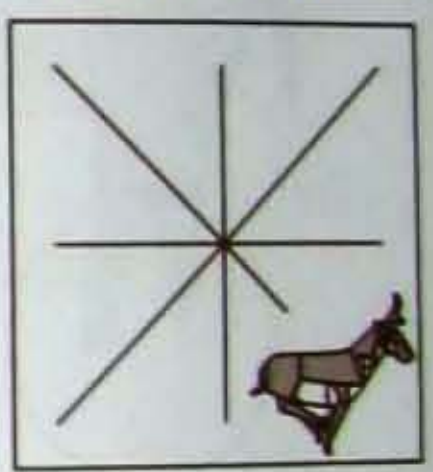

1. Valley-folds and unfold.

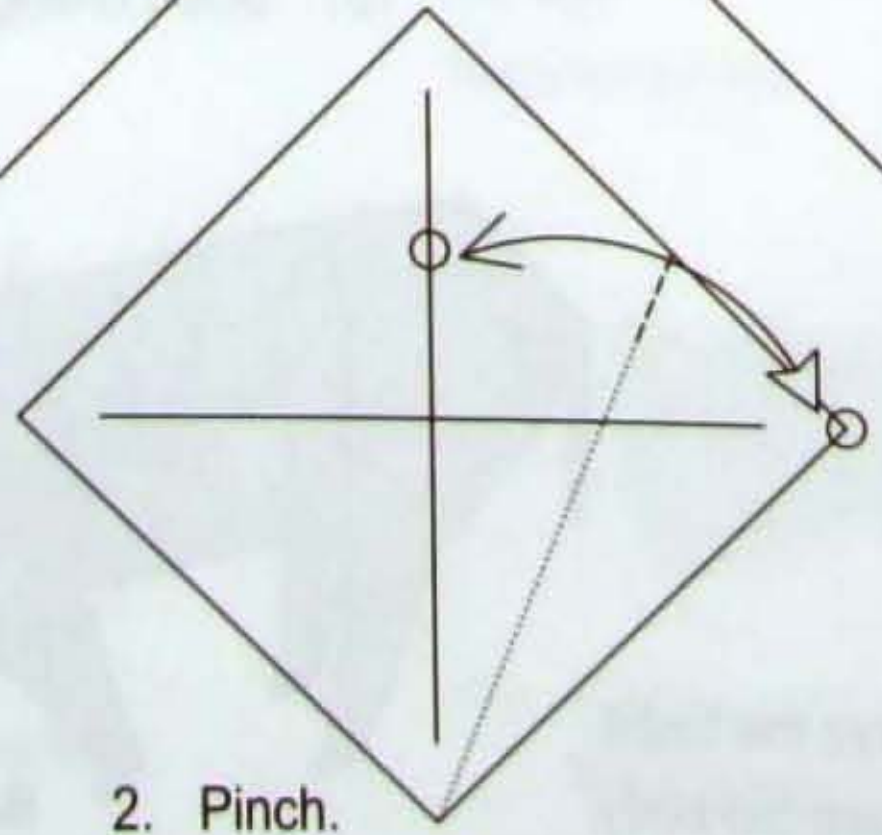

2. Pinch.

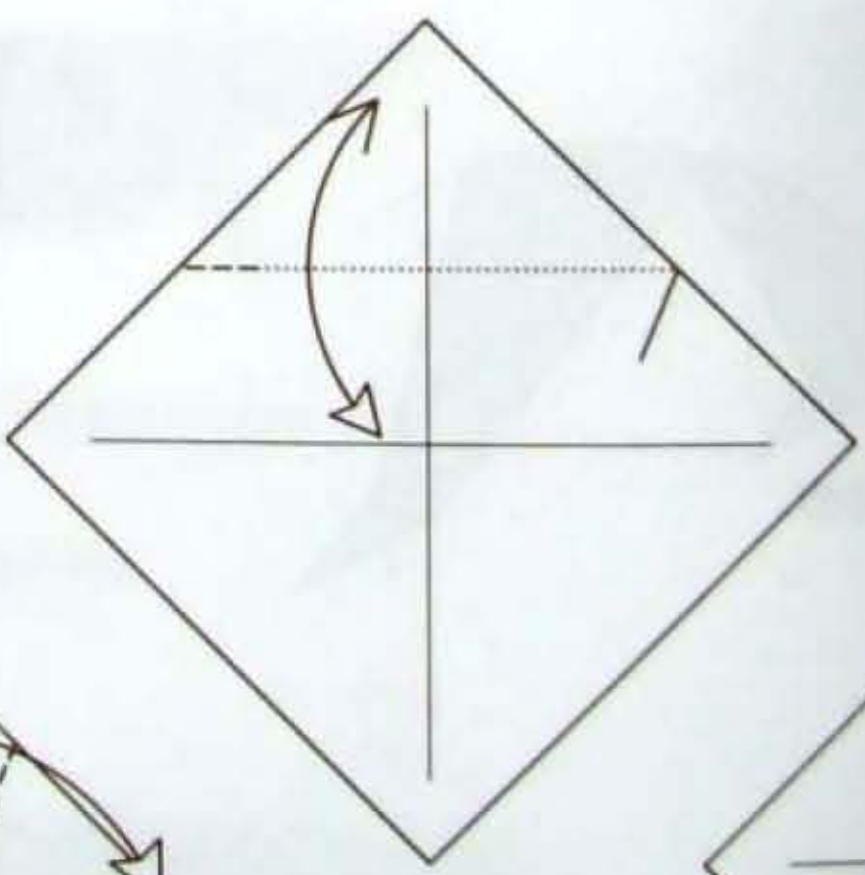

3. Pinch.

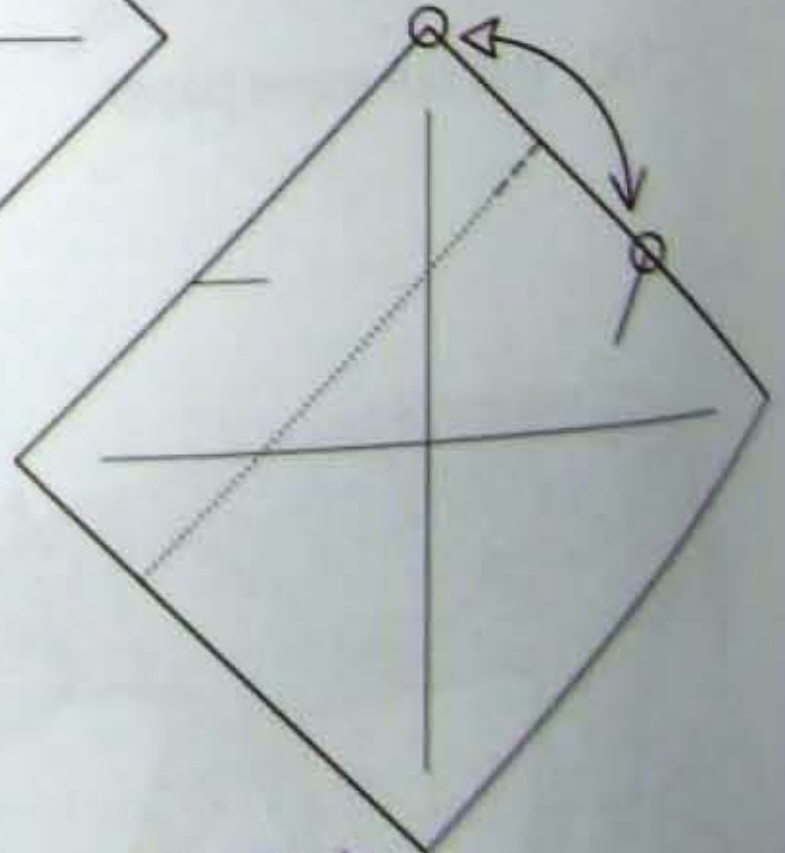

4. Pinch.

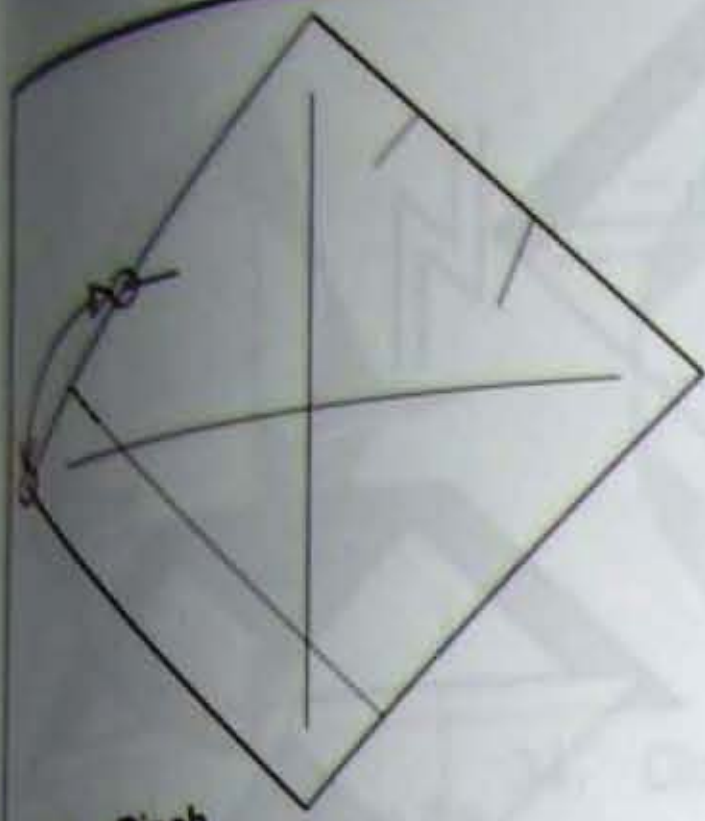

5. Pinch.

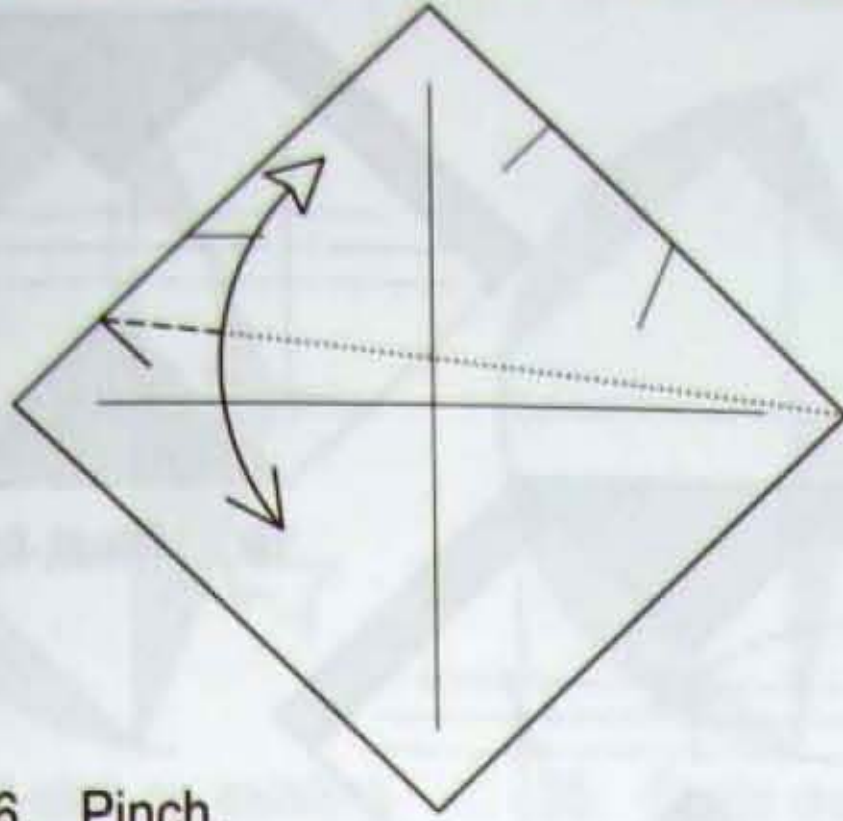

6. Pinch.

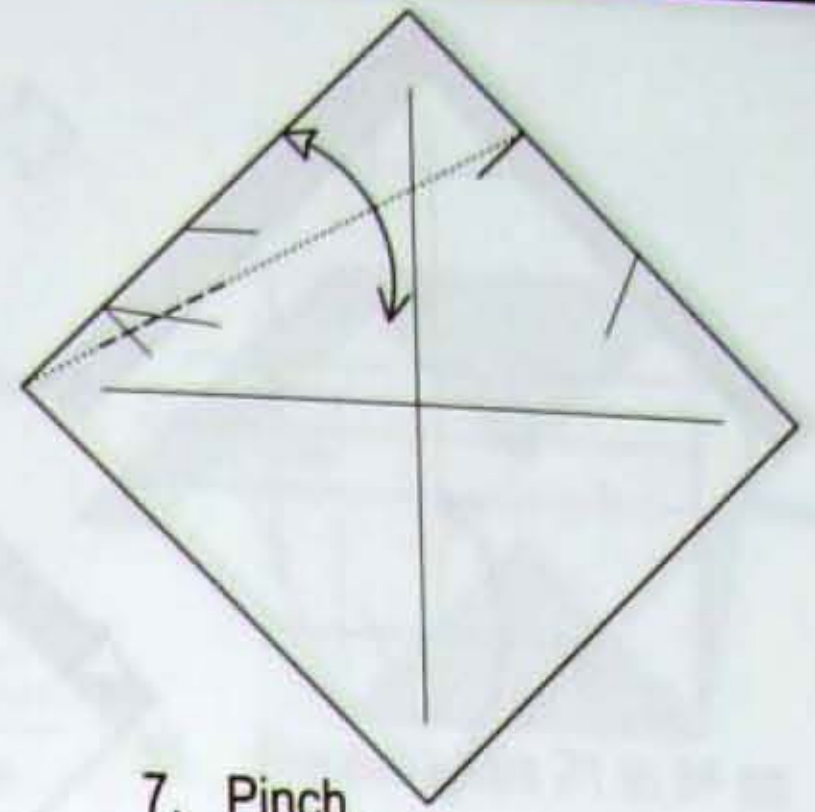

7. Pinch.

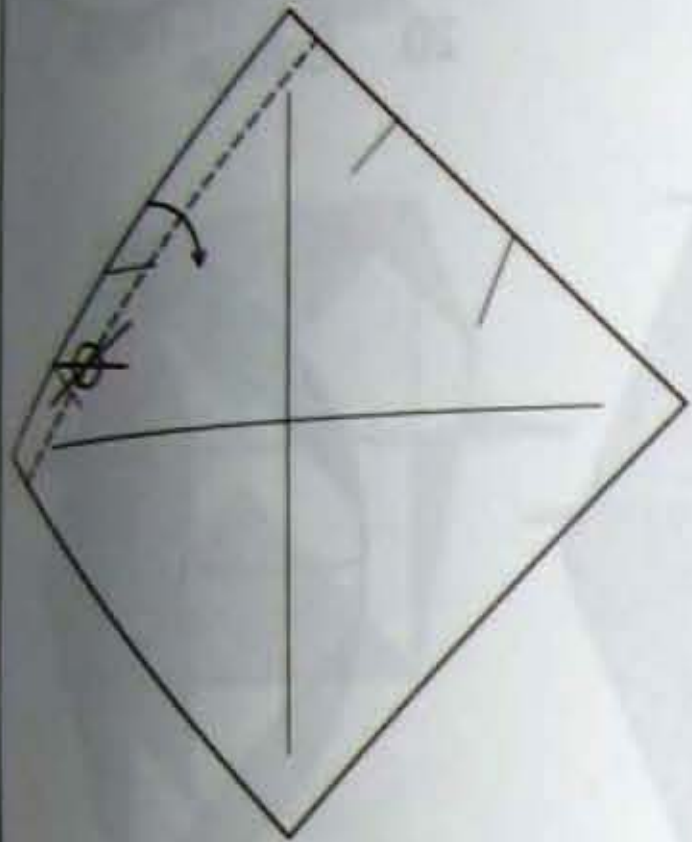

8. Valley-fold.

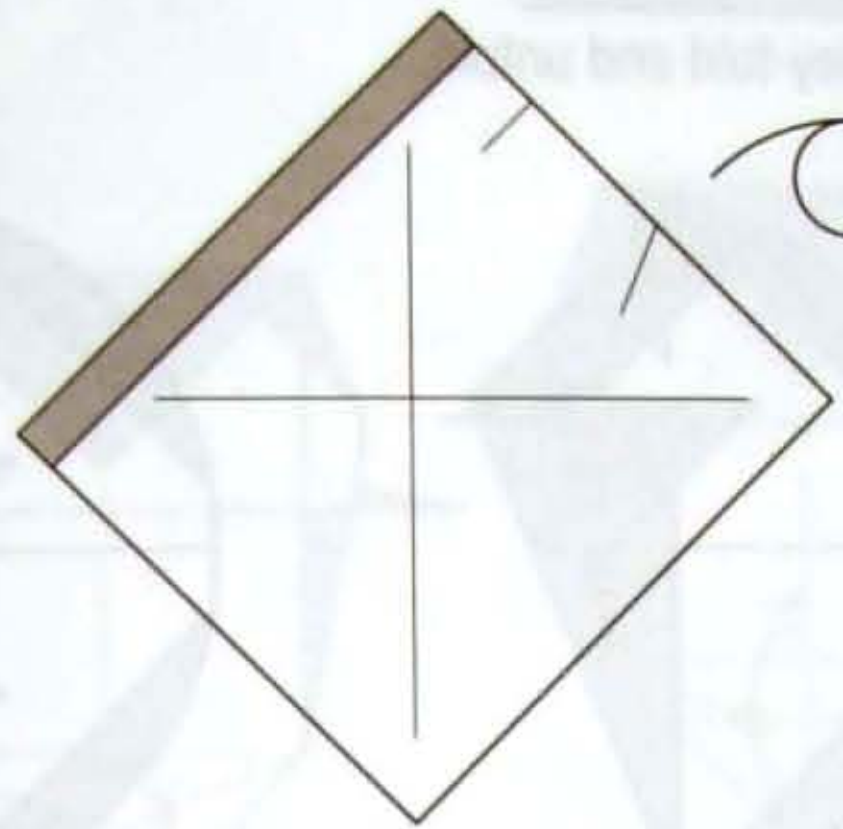

9. Turn over.

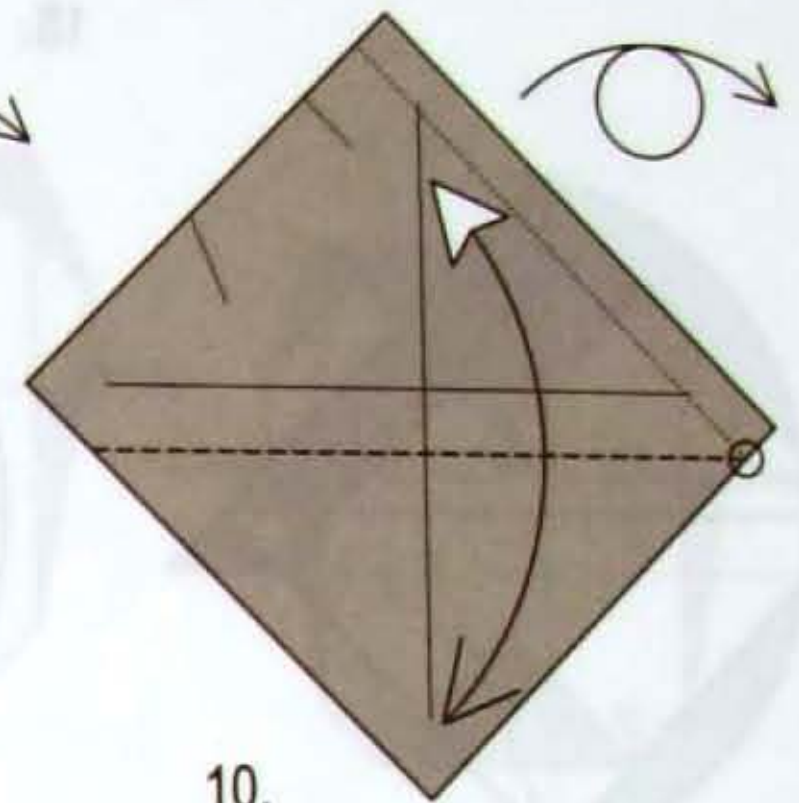

10. Valley-fold and unfold. Turn over.

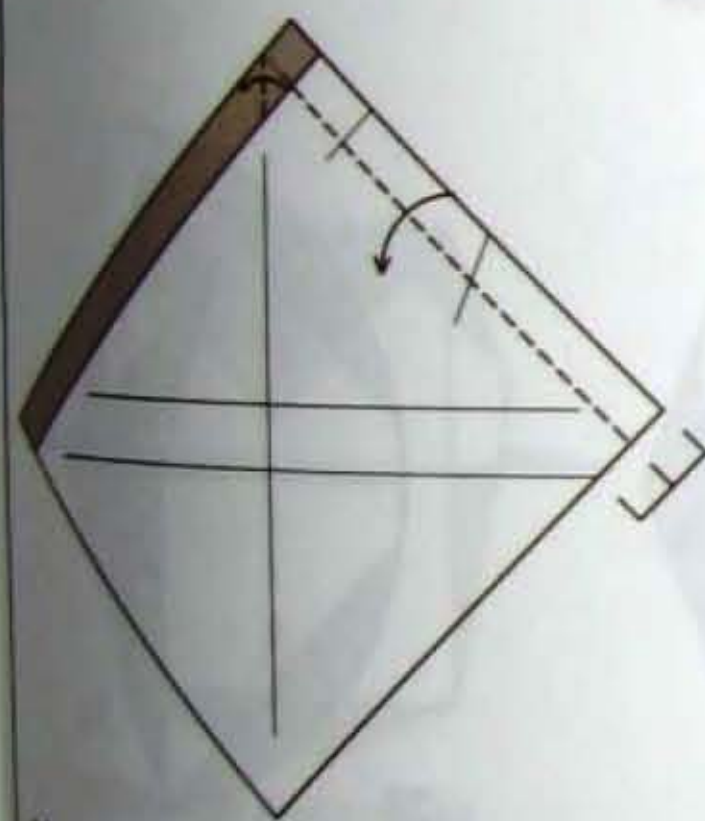

11. Preliminary-fold.

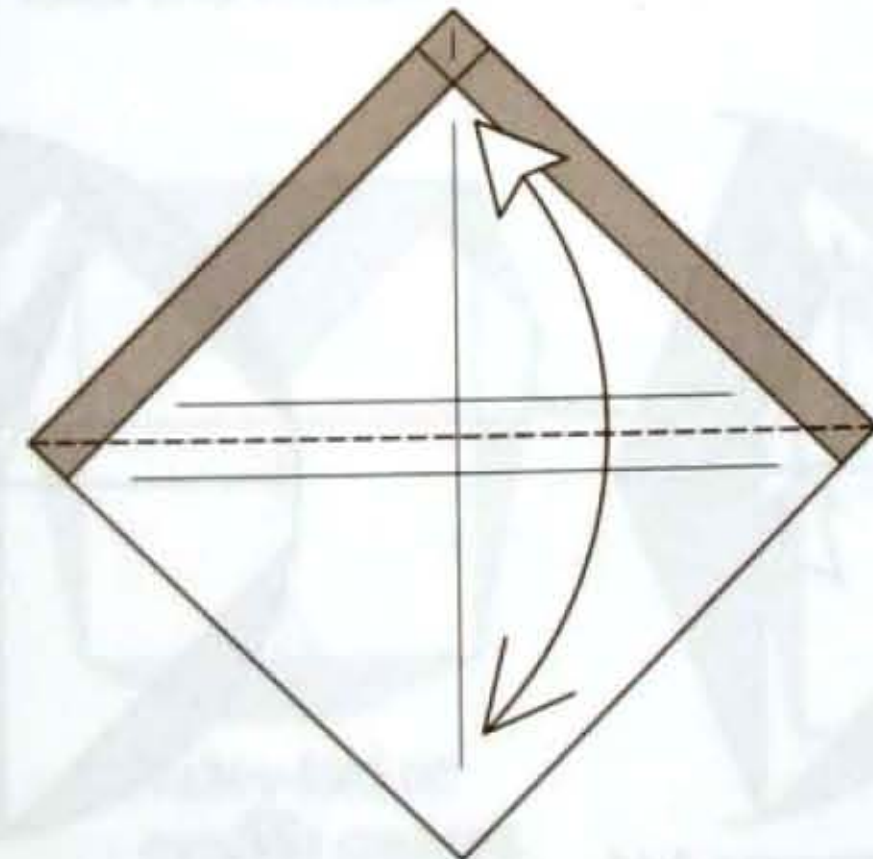

12. Valley-fold and unfold.

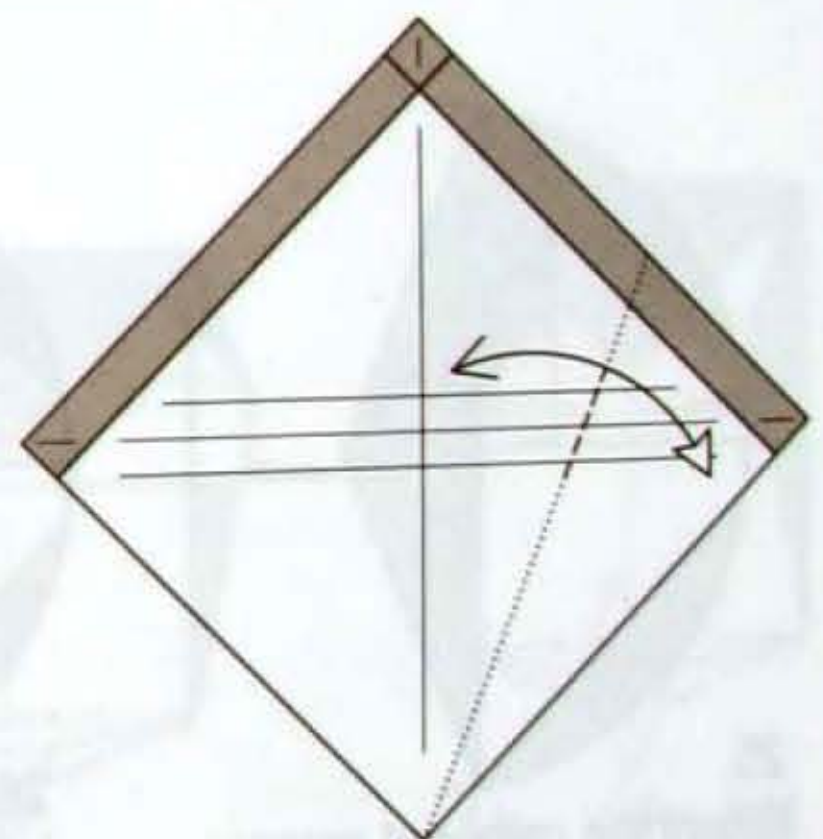

13. Pinch.

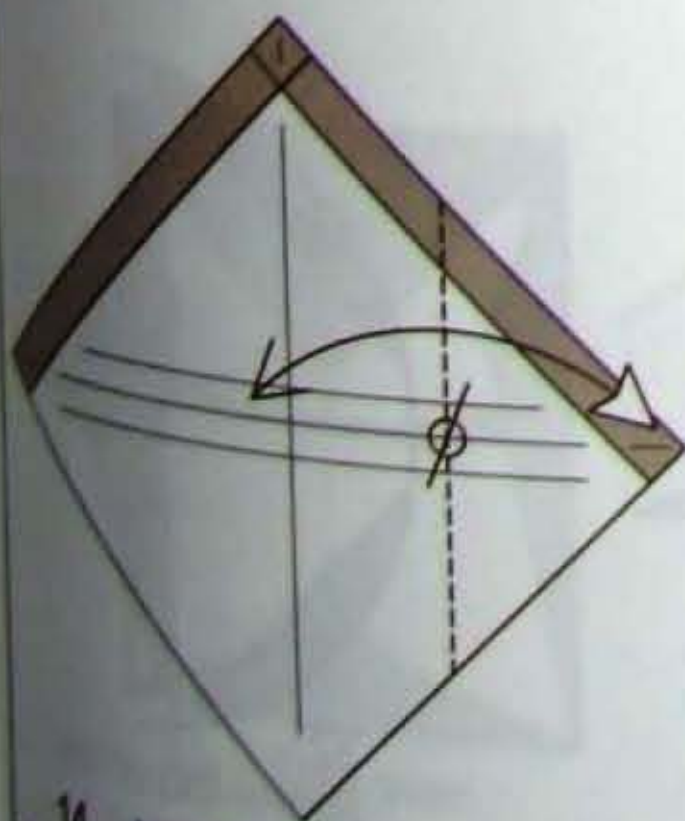

14. Valley-fold and unfold.

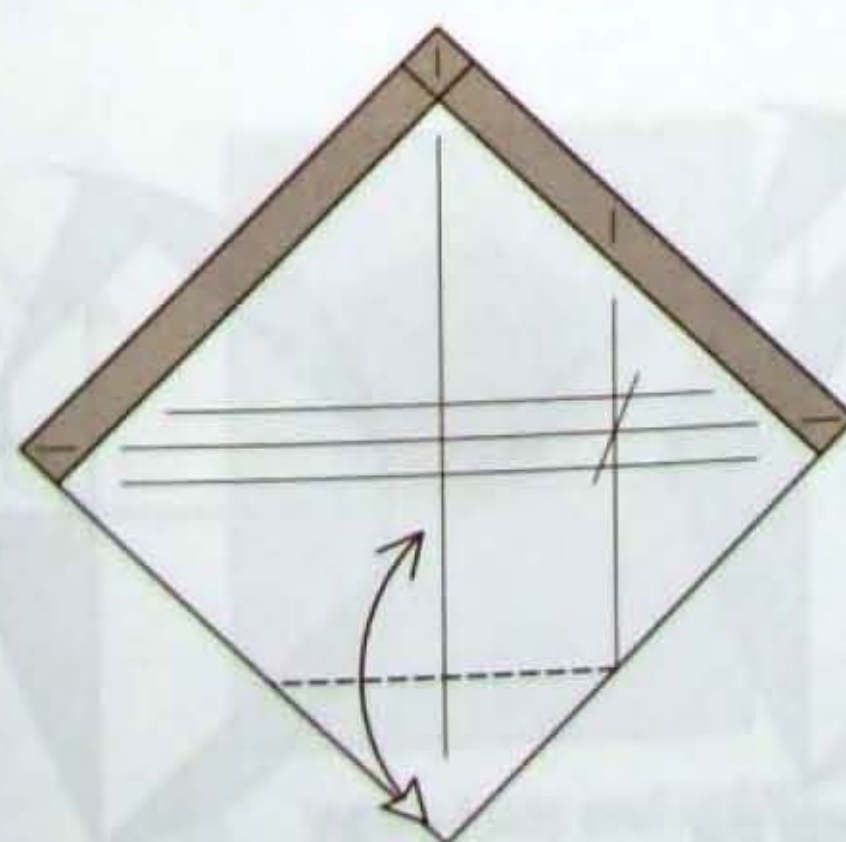

15. Valley-fold and unfold.

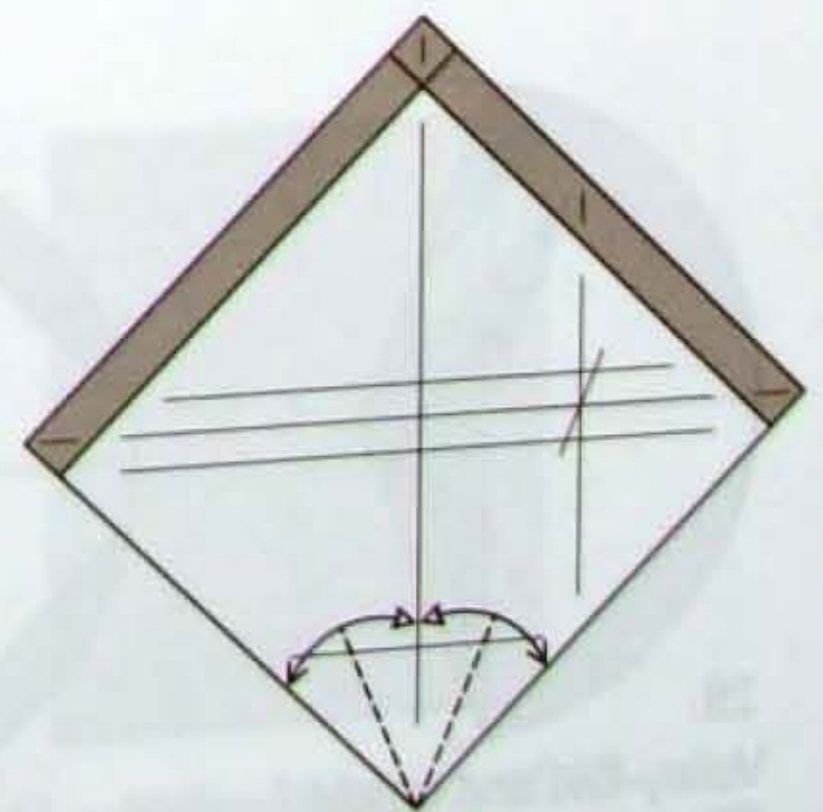

16. Pre-creases.

are
own
No
Ok
Best

length

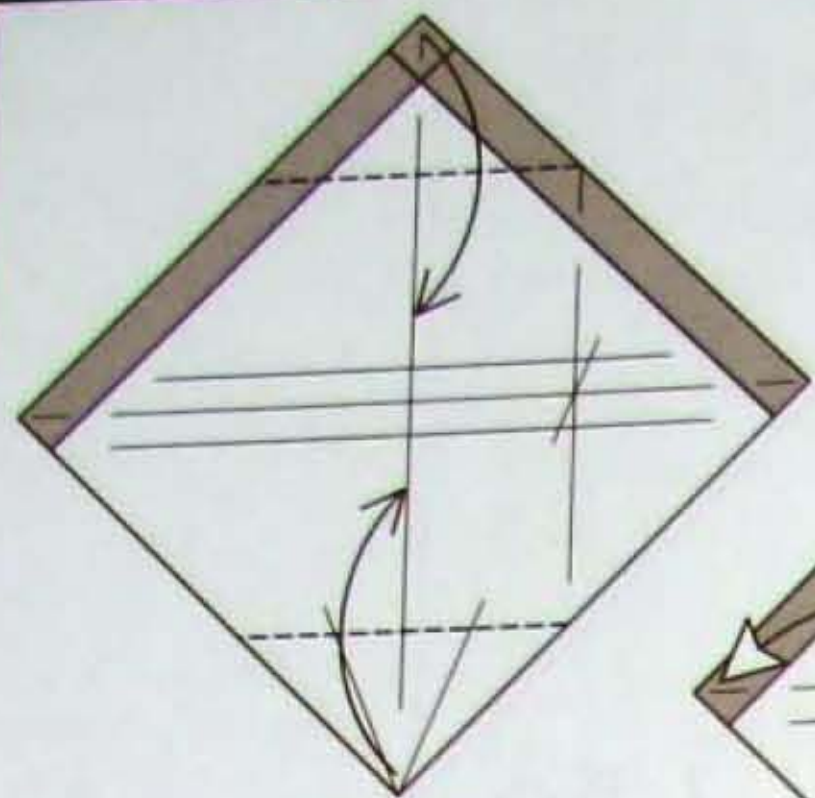

17. Valley-folds.

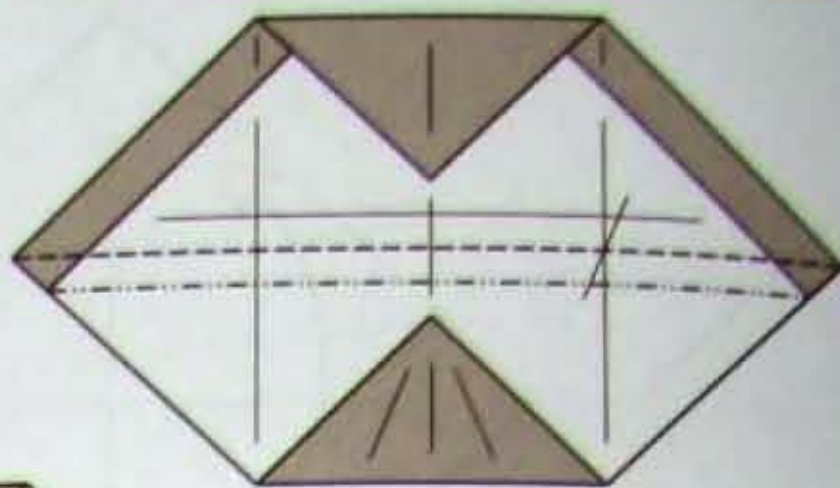

19. Pleat-fold.

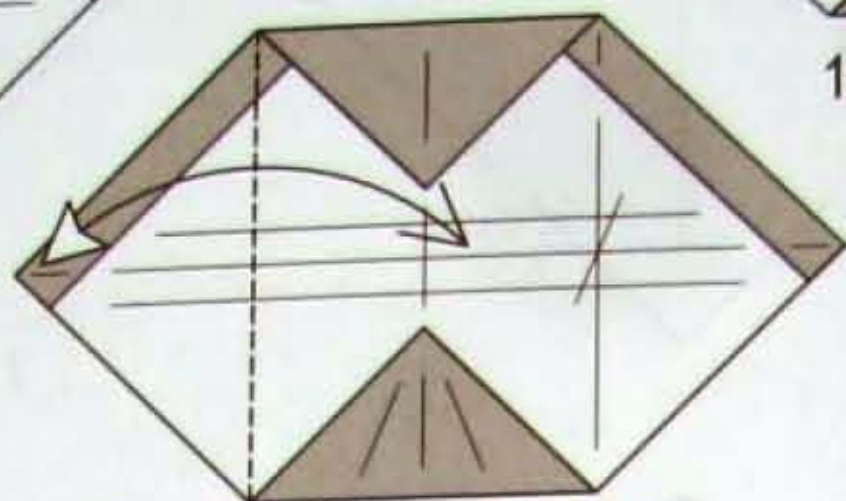

18. Valley-fold and unfold.

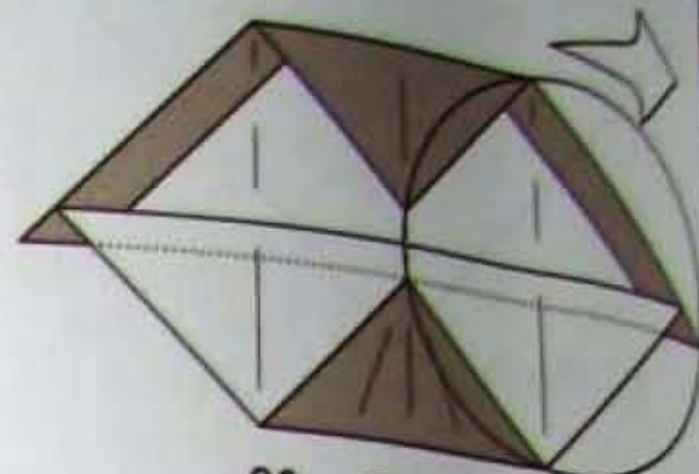

20. Enlarge.

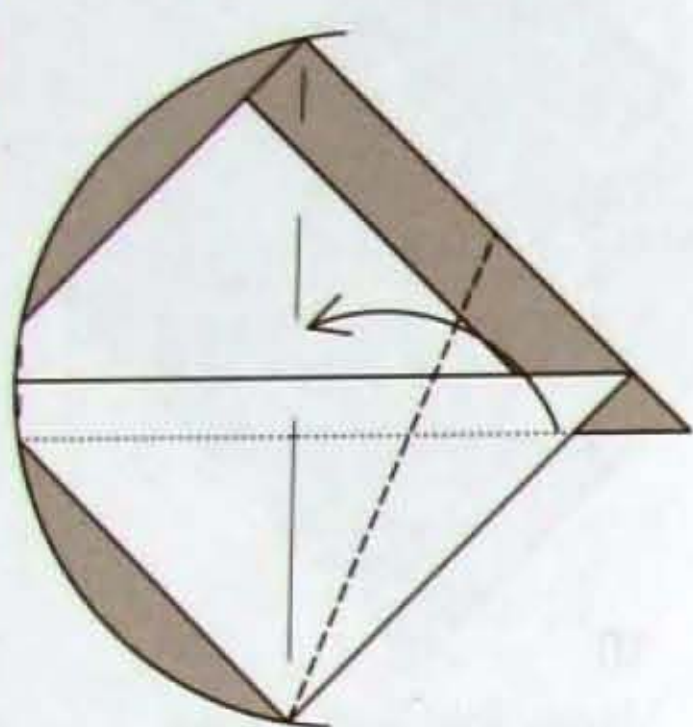

21. Valley-fold.

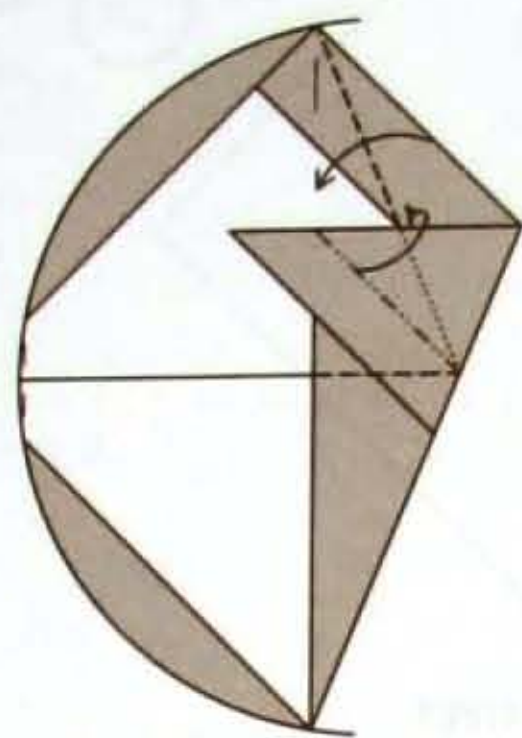

22. Rabbit-ear.

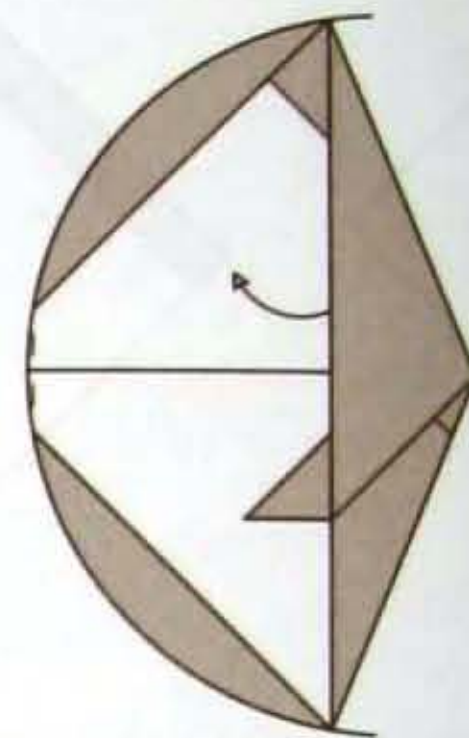

23. Unfold the raw edge.

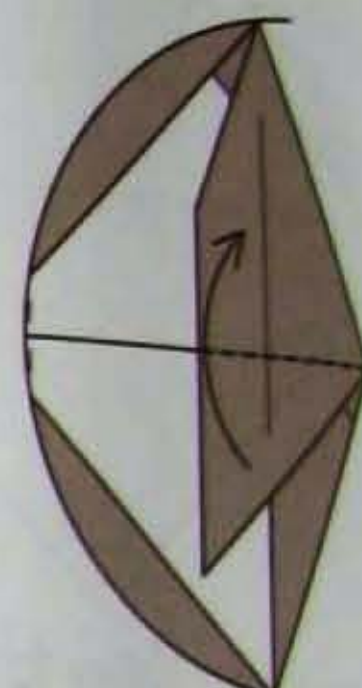

24. Valley-fold.

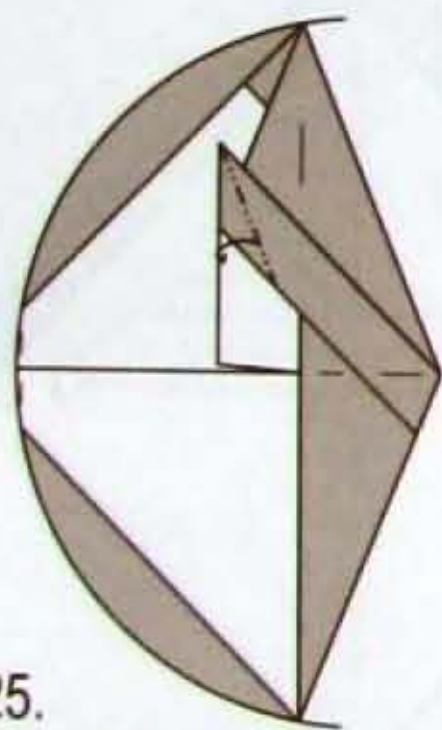

25. Bisect the coloured corner with a mountain-fold.

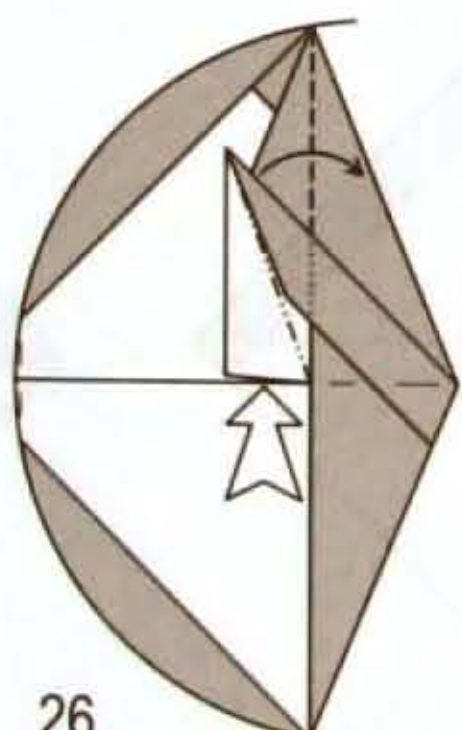

26. Inside reverse-fold.

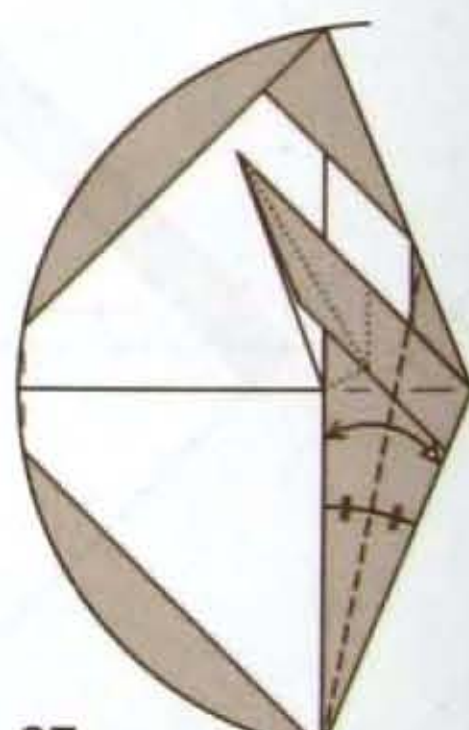

27. Valley-fold and unfold.

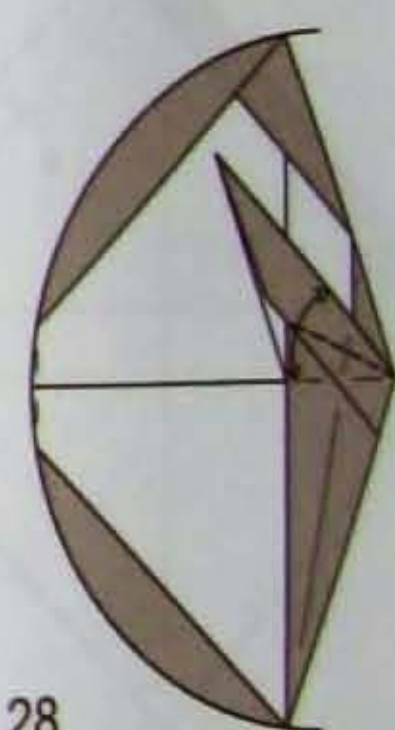

28. Valley-fold and unfold. (Bisect the corner).

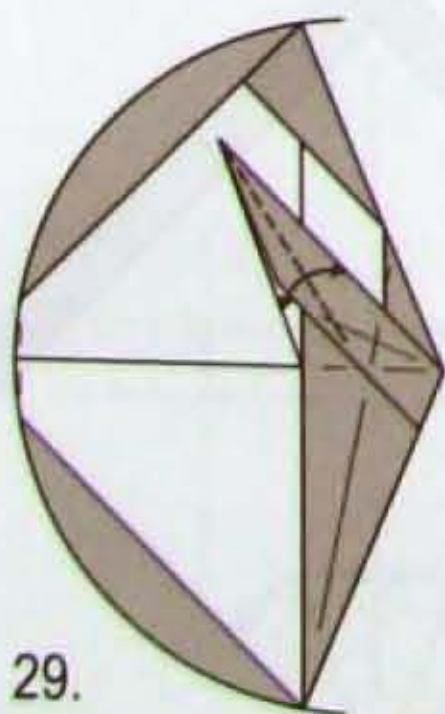

29. Valley-fold and unfold. (Bisect the corner).

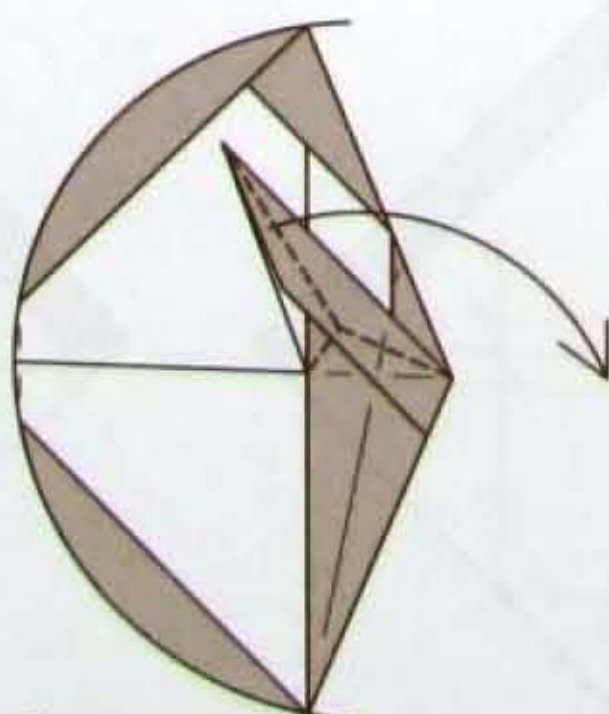

30. Rabbit-ear the top layers only.

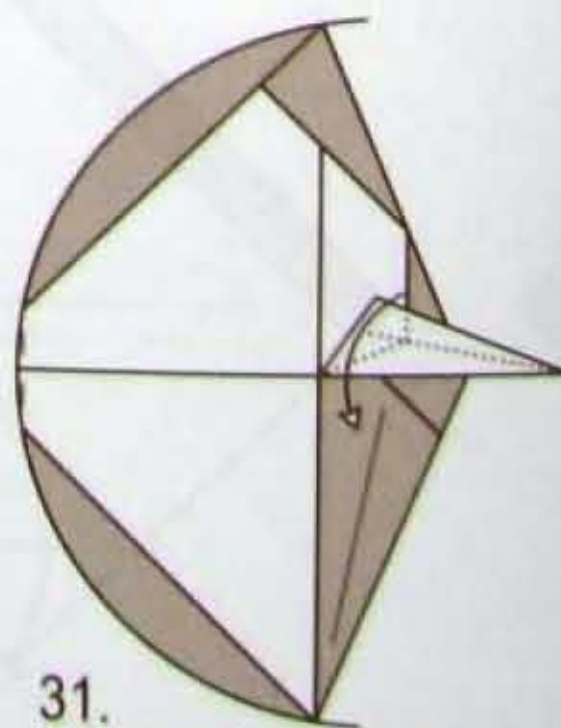

31. Untrap the white layer.

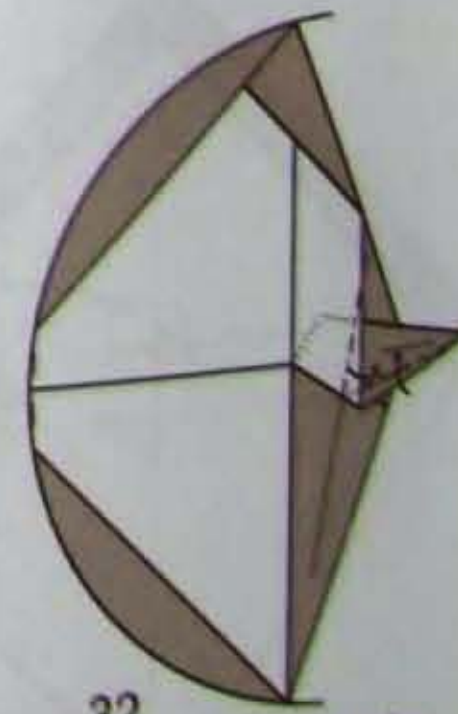

32. Swivel-fold on the crease behind.

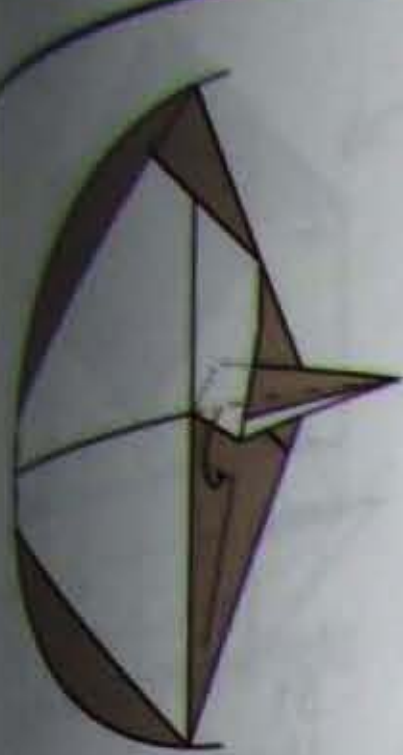

33. Mountain-fold into the layers underneath.

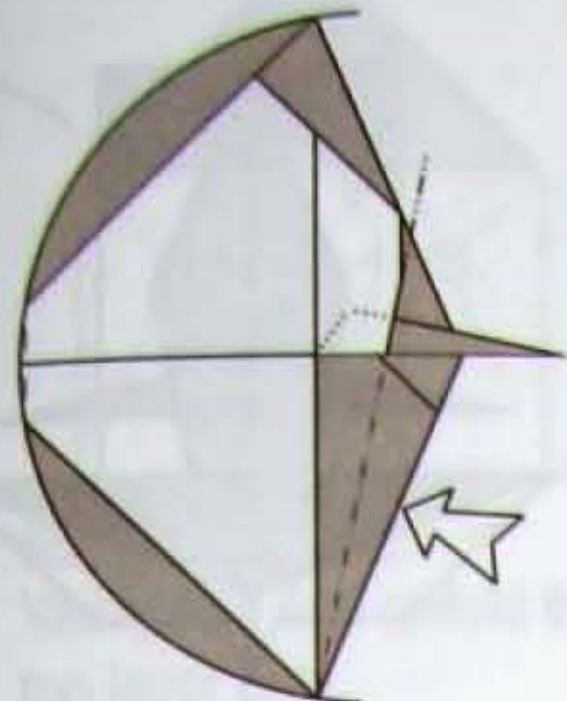

34. Closed-sink on existing crease.

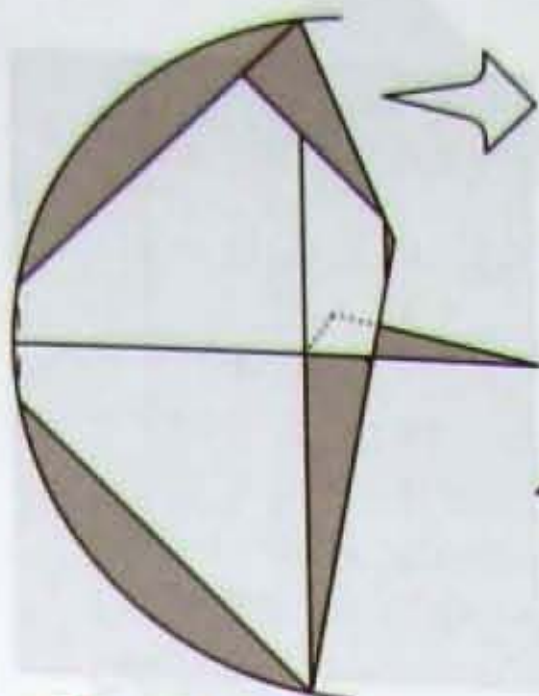

35. Scale change.

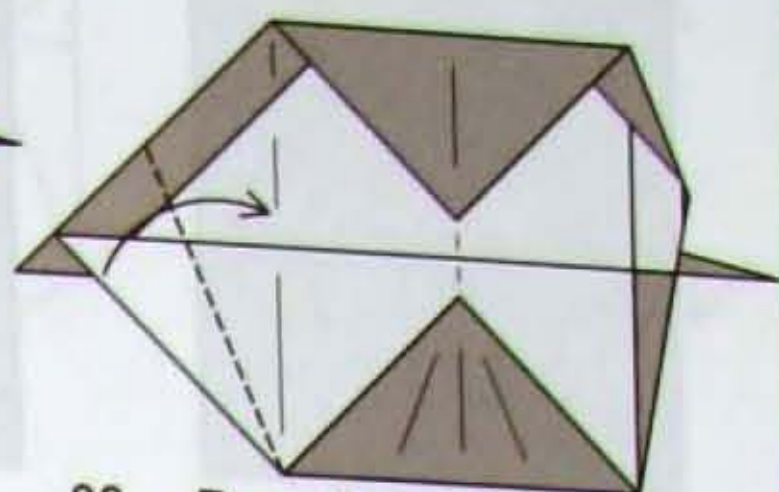

36. Repeat steps 21 to 34 on the left.

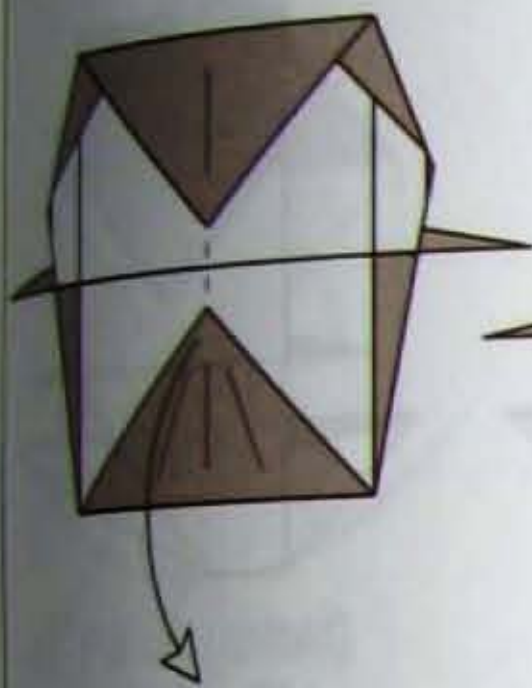

37. Unfold.

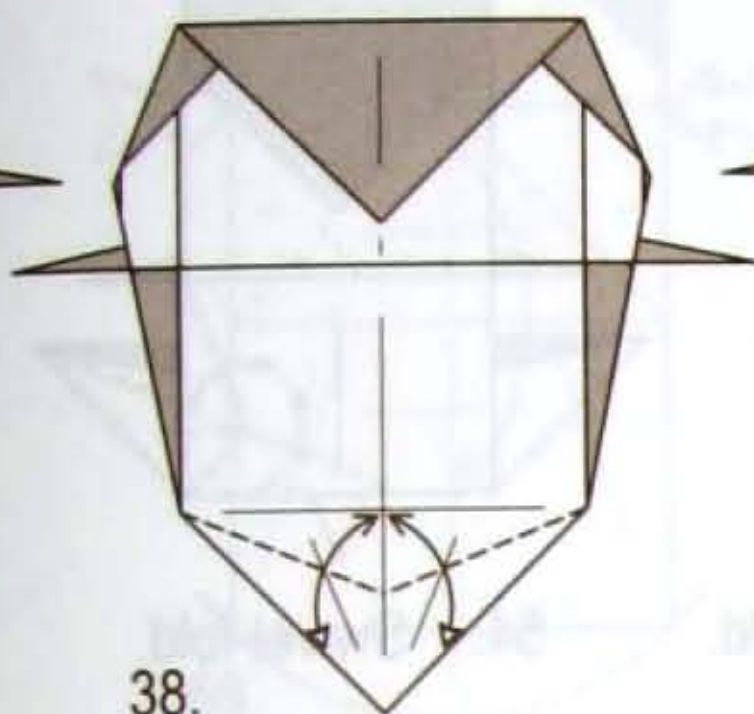

38. Valley-folds and unfold.

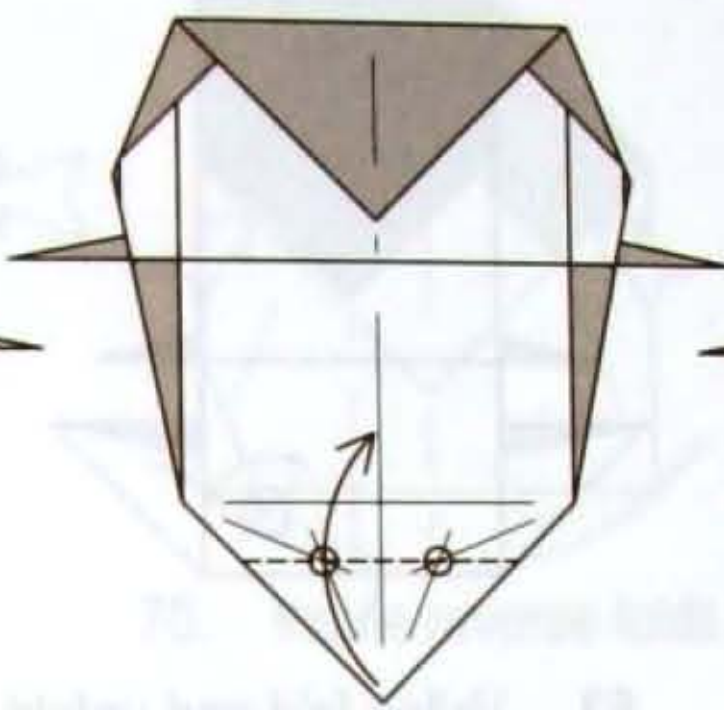

39. Valley-fold.

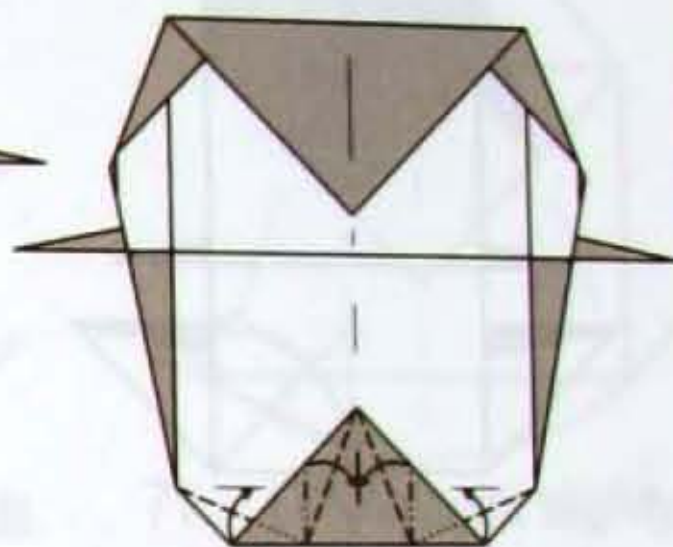

40. Swivel-folds.

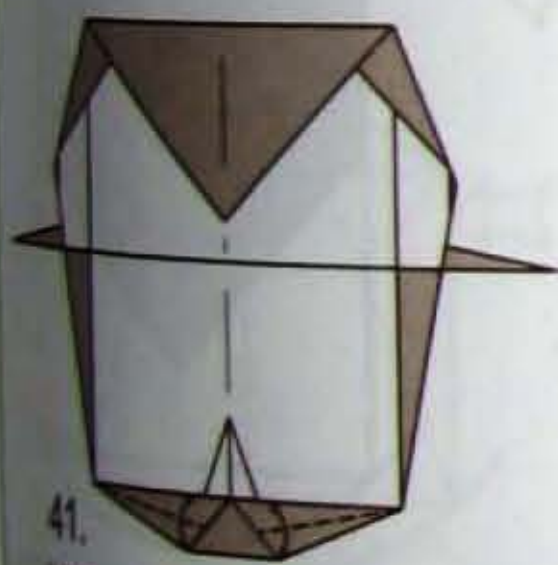

41. Valley-fold and unfold the raw edges.

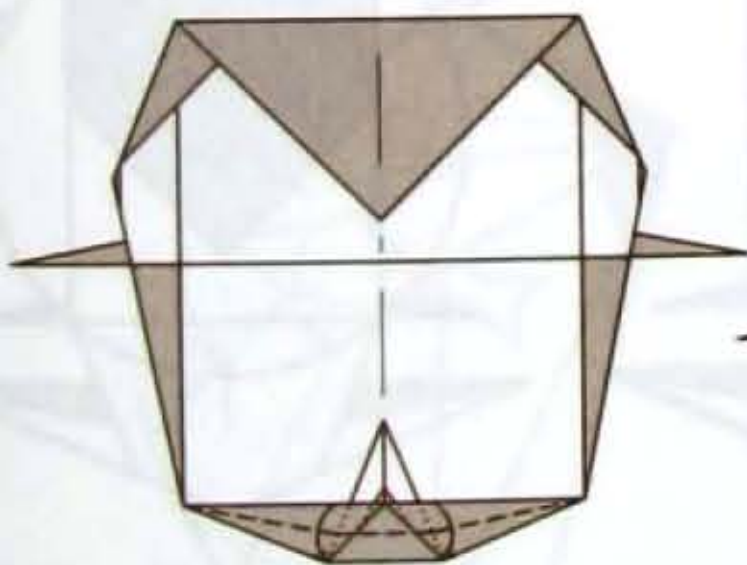

42. Valley-fold on existing creases.

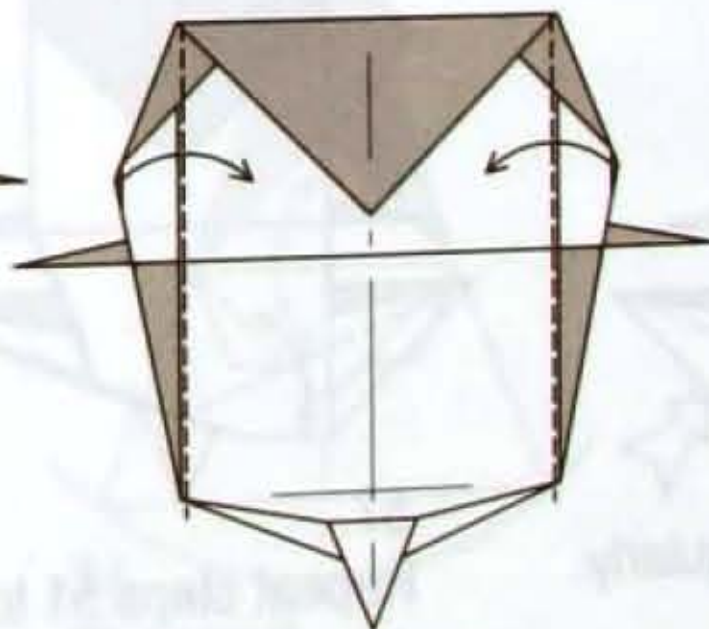

43. Valley-folds.

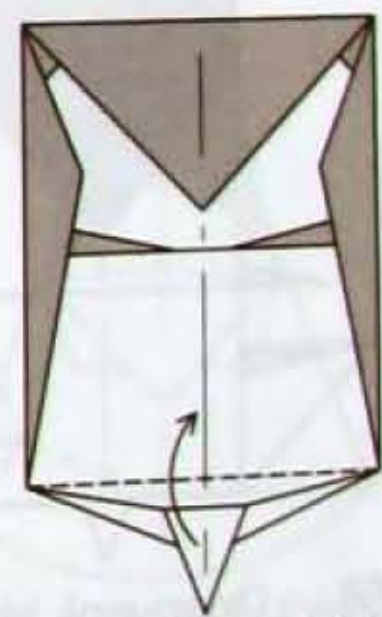

44. Valley-fold.

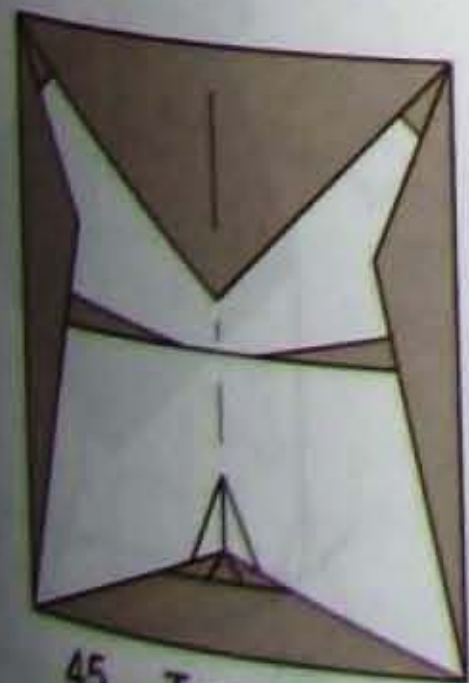

45. Turn over.

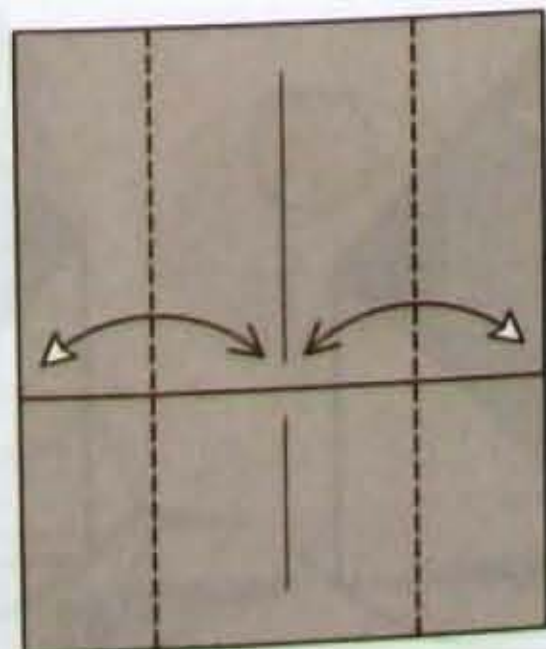

46. Valley-folds and unfold.

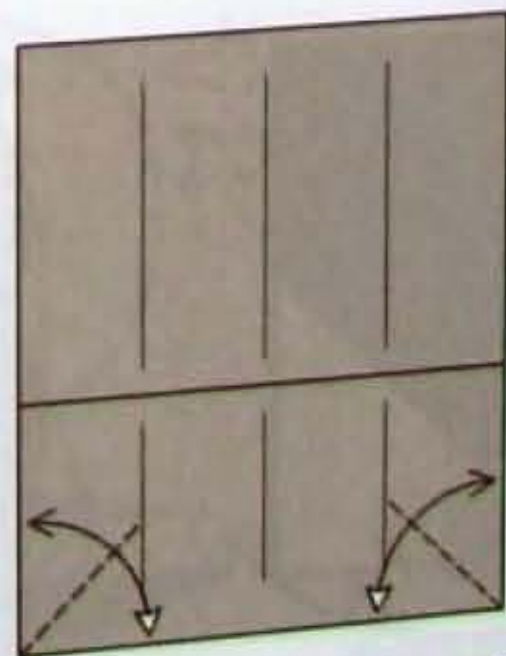

47. Valley-folds and unfold.

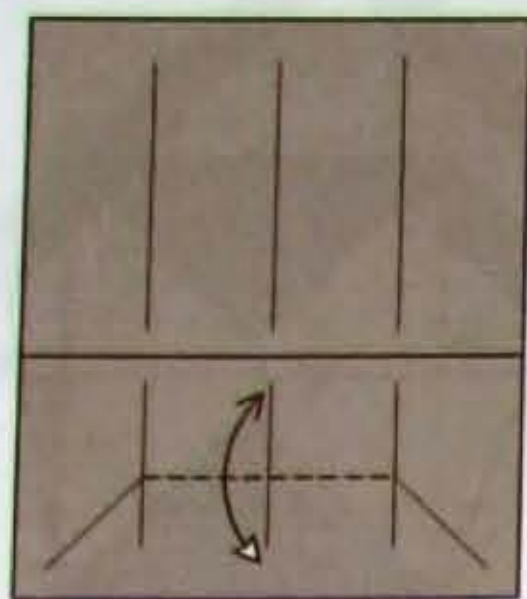

48. Valley-fold and unfold.

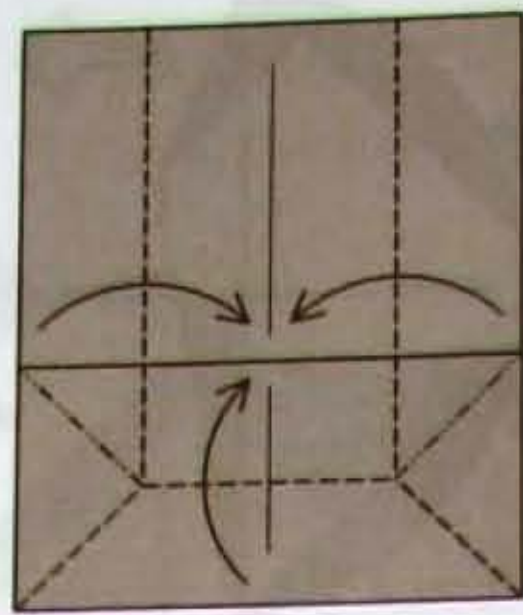

49. Rabbit-ear on both sides.

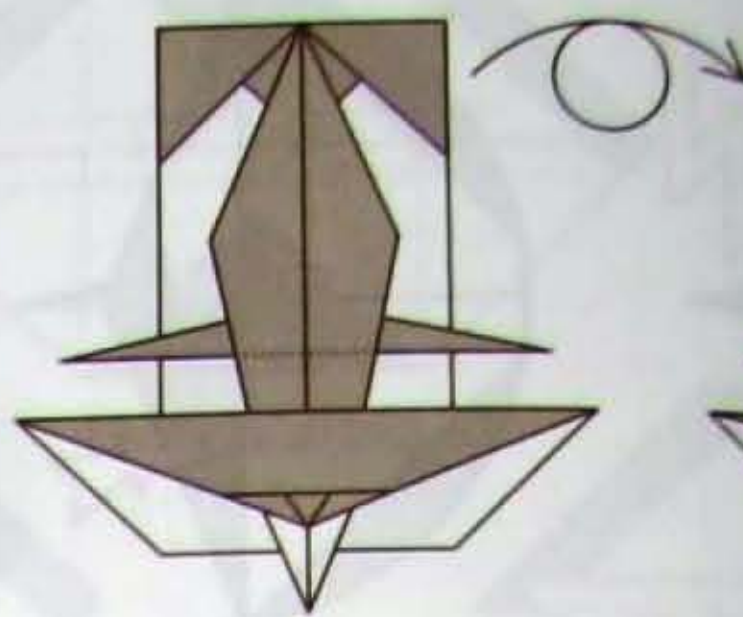

50. Turn over.

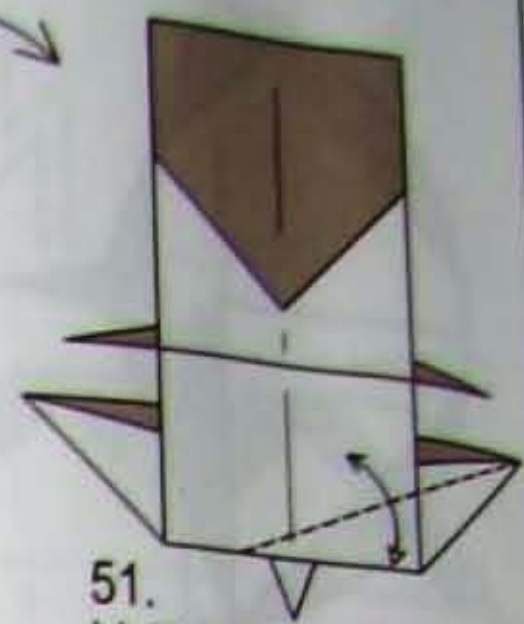

51. Valley-fold and unfold.

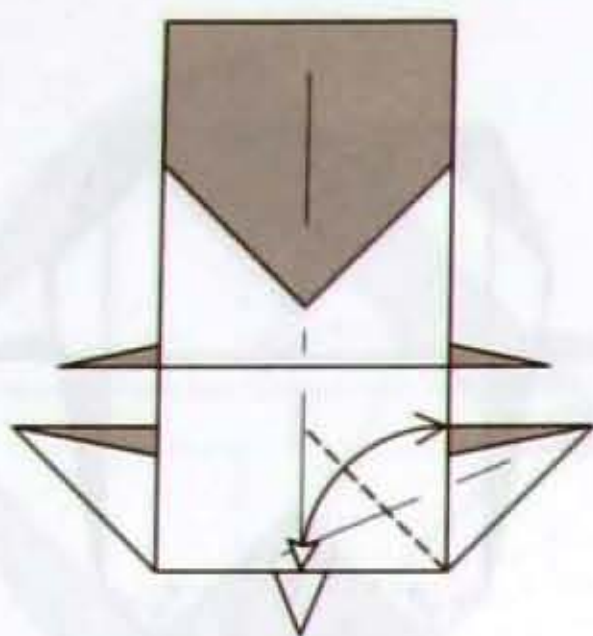

52. Valley-fold and unfold.

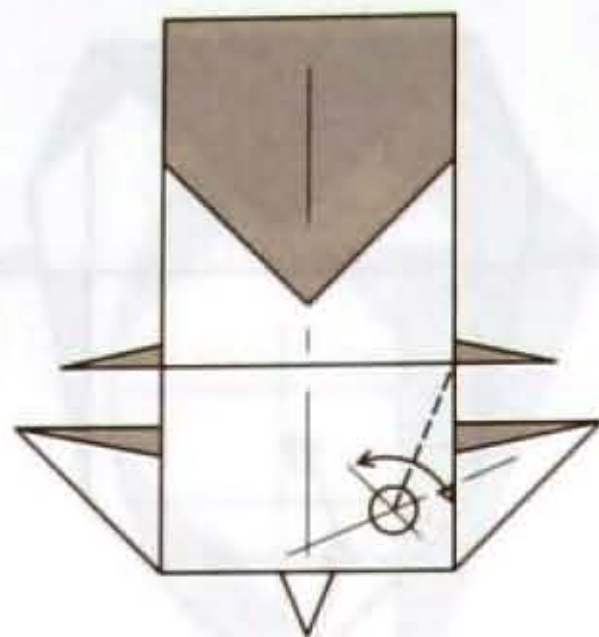

53. Valley-fold and unfold.

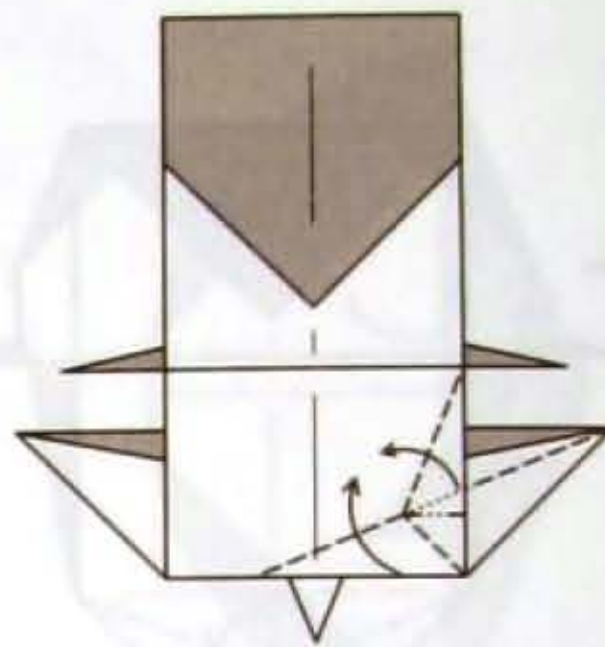

54. Swivel-fold.

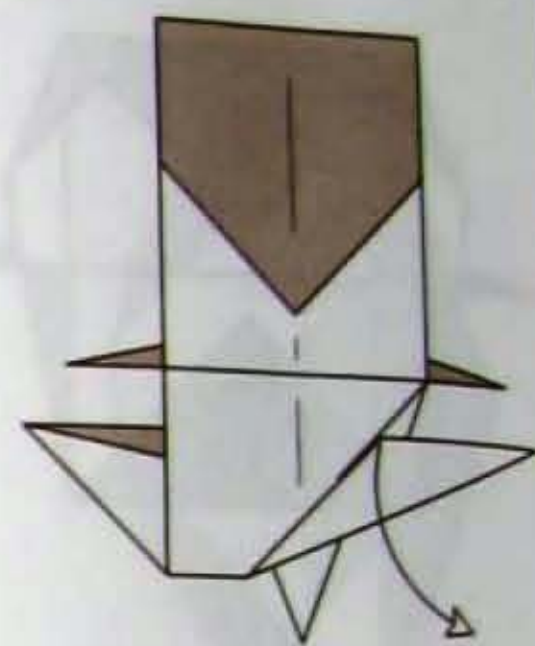

55. Unfold.

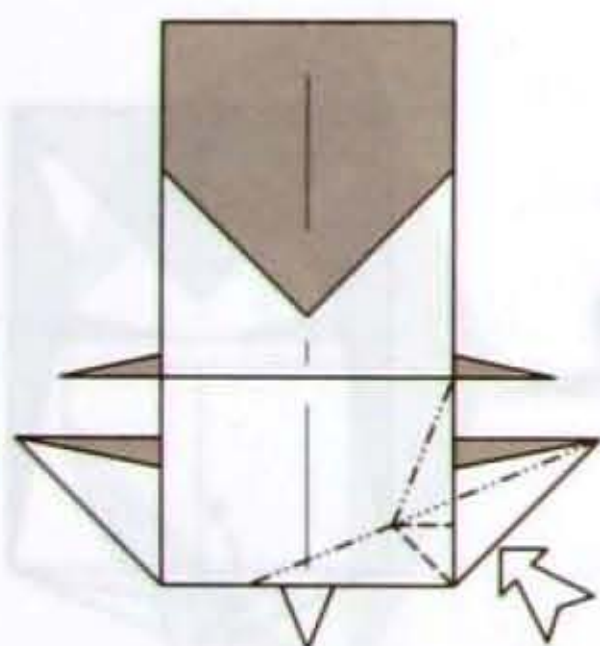

56. Open-sink triangularly.

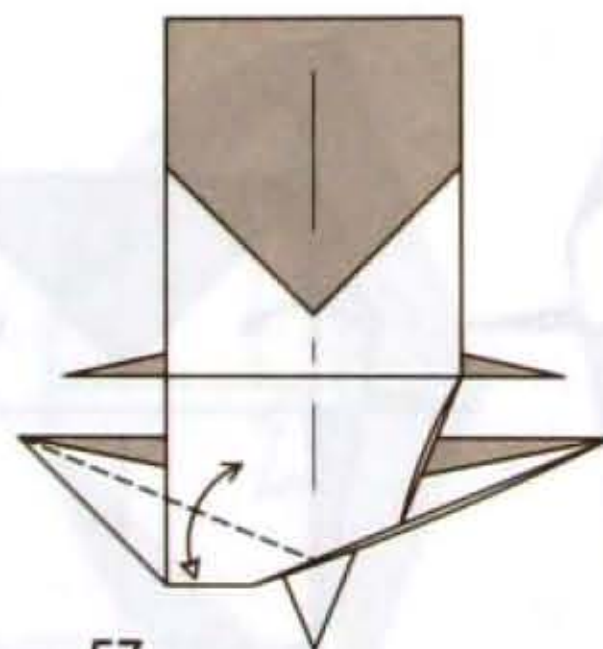

57. Repeat steps 51 to 56 on the left.

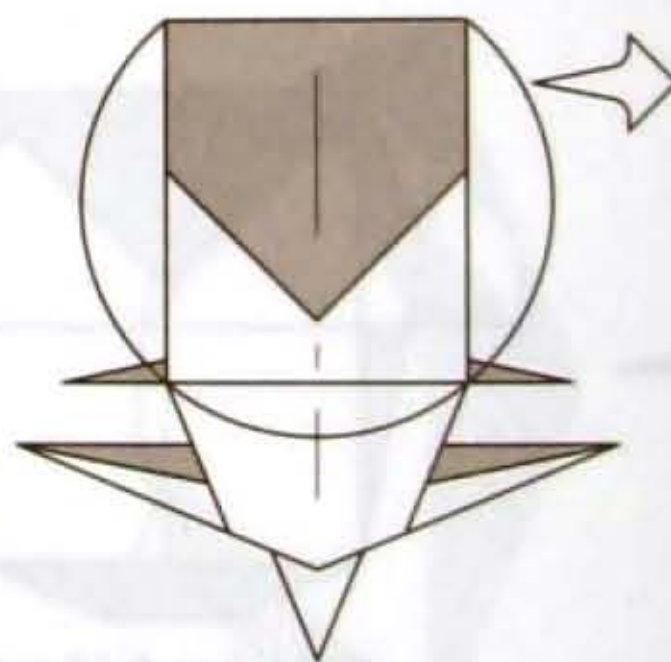

58. Enlarge.

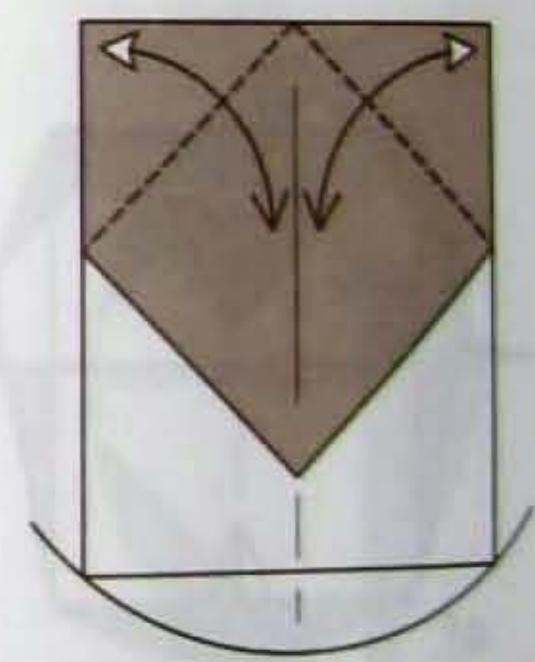

59. Valley-folds and unfold.

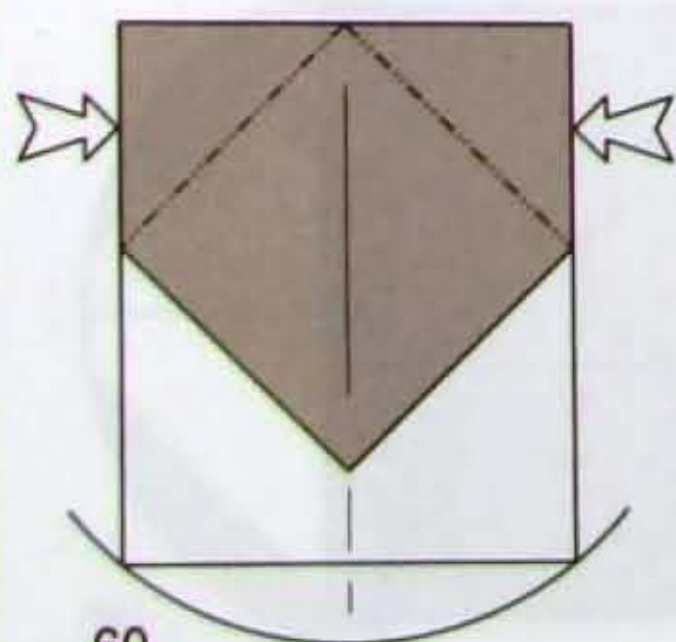

60. Inside reverse-folds.

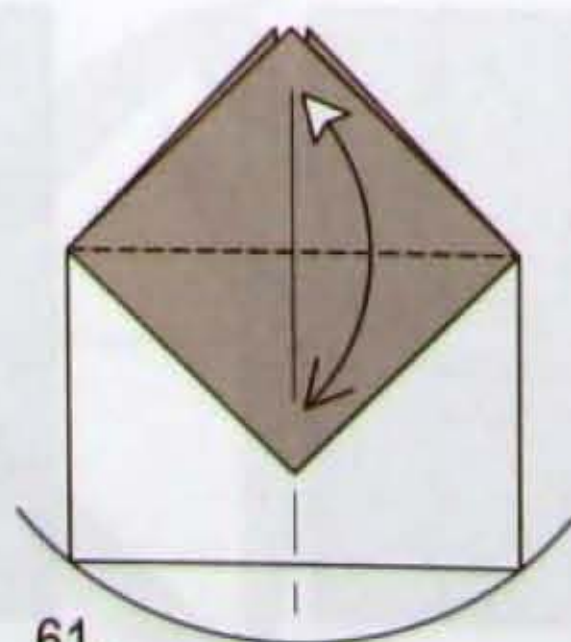

61. Valley-fold and unfold.

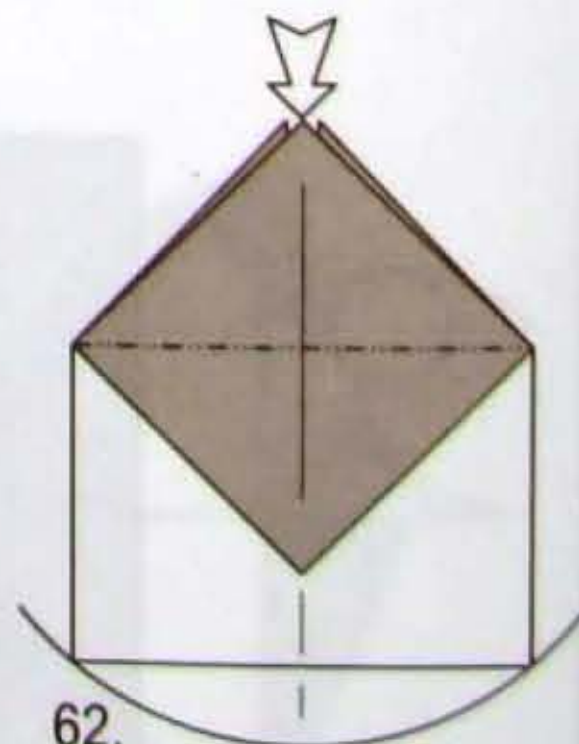

62. Inside reverse-fold.

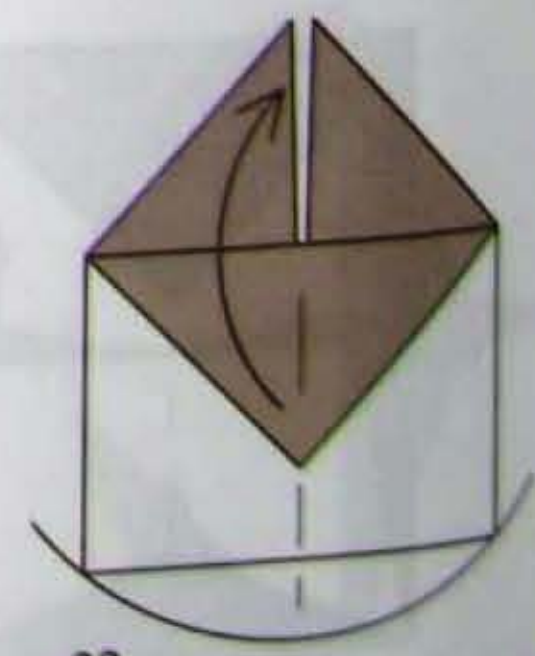

63. Valley-fold the corner up.

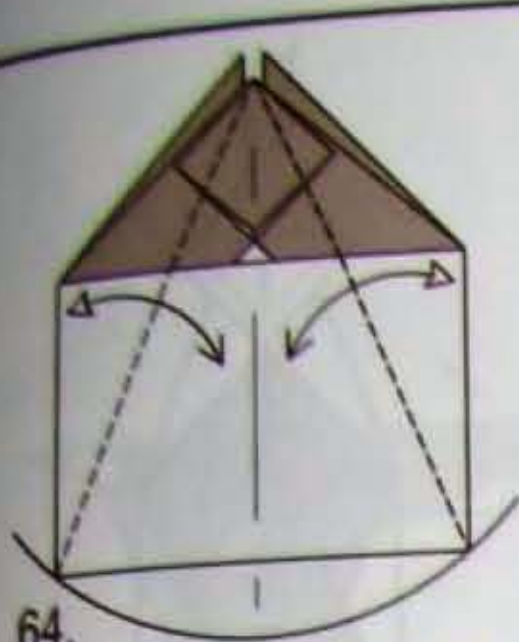

64. Valley-folds and unfold through all layers.

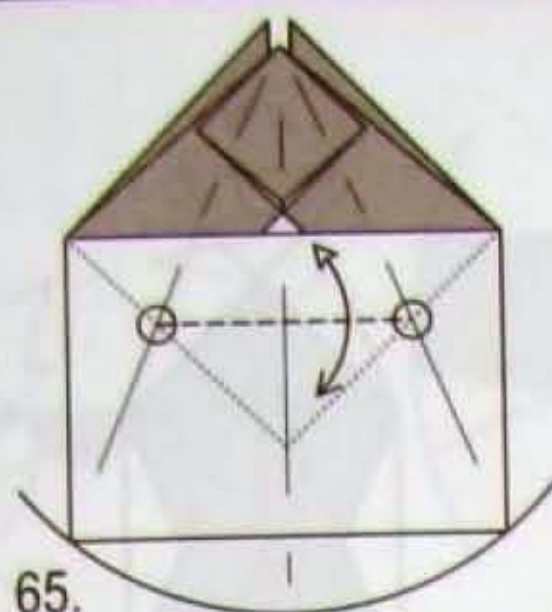

65. Valley-fold and unfold the top layer only. See markers.

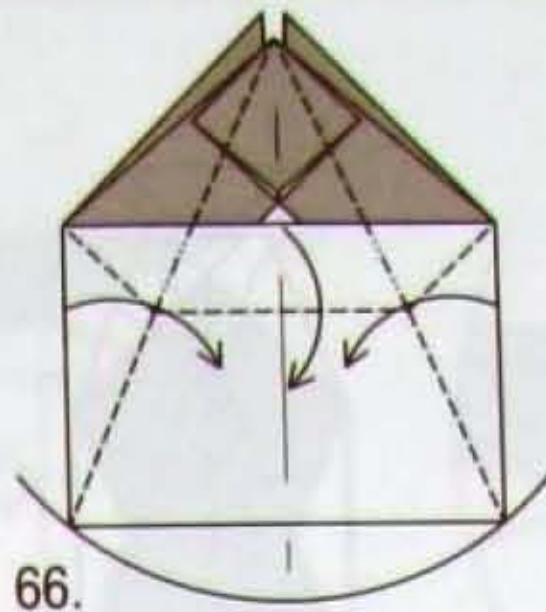

66. Collapse on existing creases.

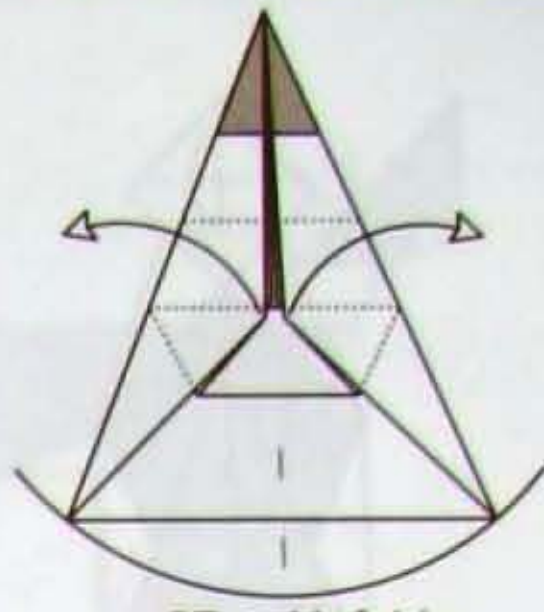

67. Unfolds.

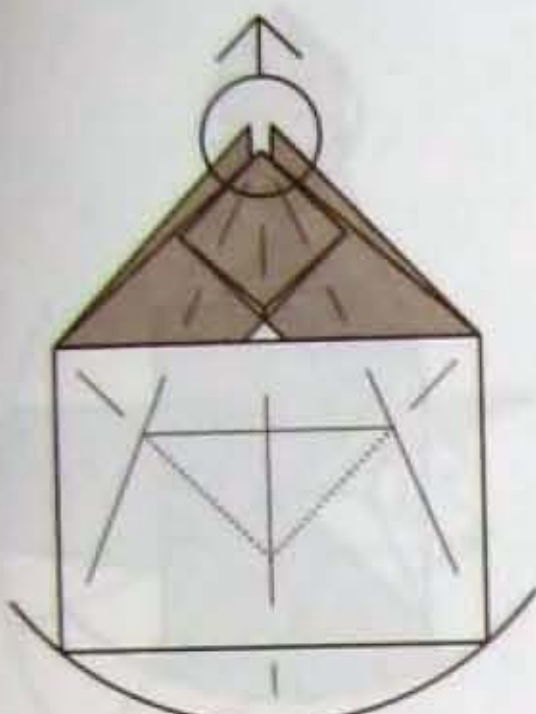

68. Pull out (unfold) the hidden corner.

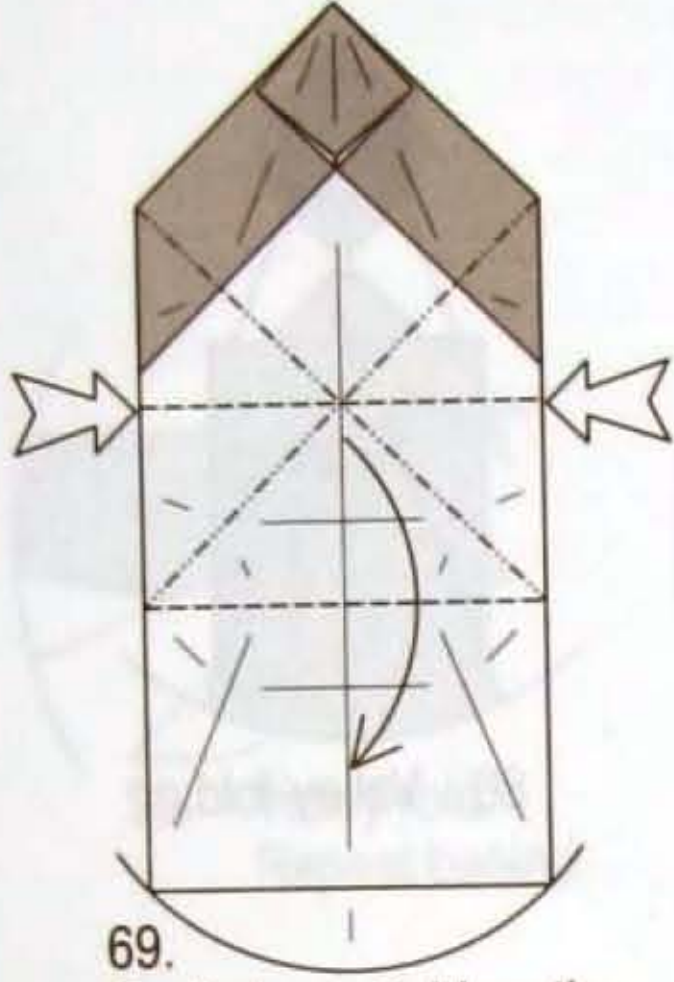

69. Preliminary Fold on the existing creases.

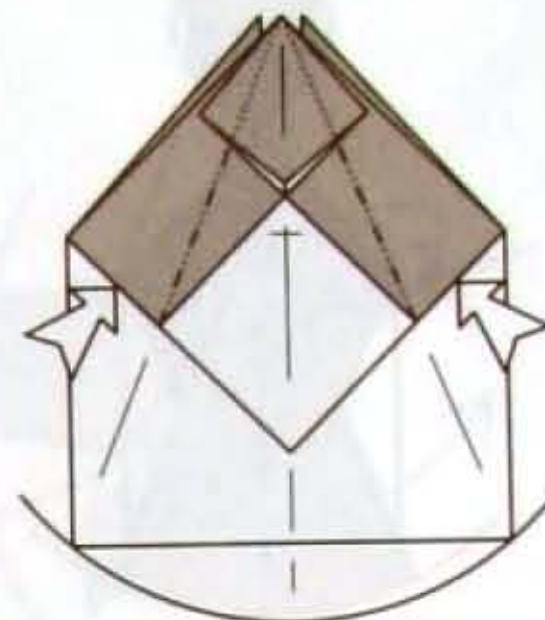

70. Inside reverse-folds.

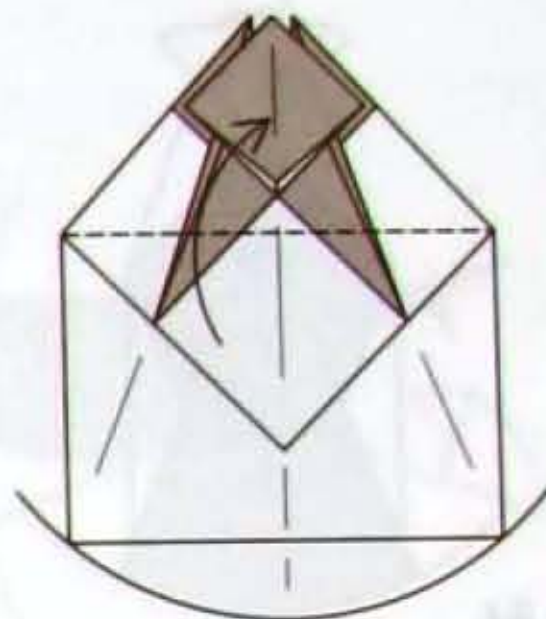

71. Lift the point slightly.

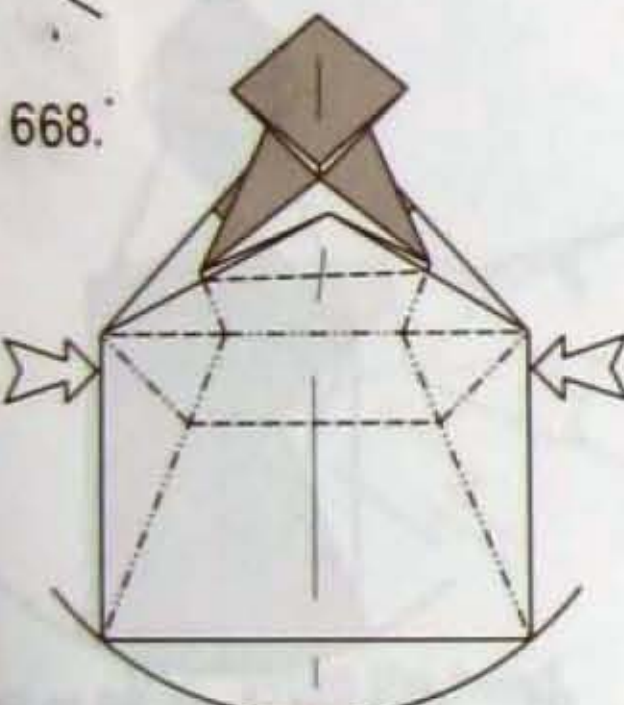

72. Open-sink on both sides on creases made in steps 62 to 65.

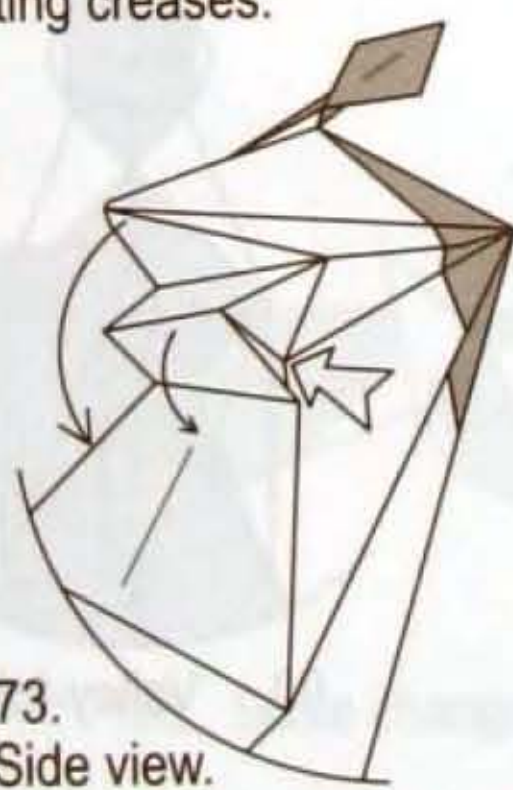

73. Side view. Open-sink the indicated point and then flatten.

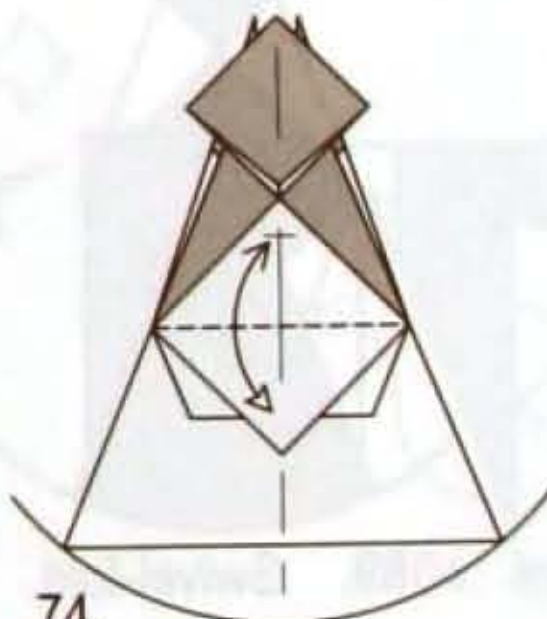

74. The result. Valley-fold and unfold.

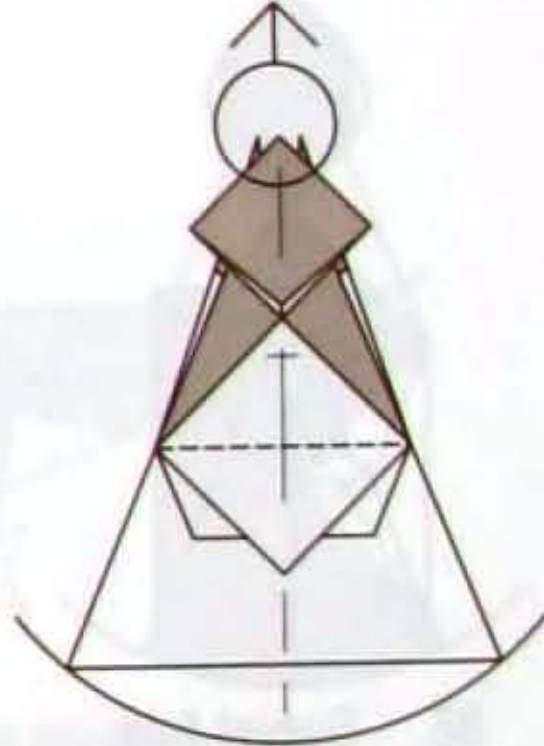

75. Stretch-fold.

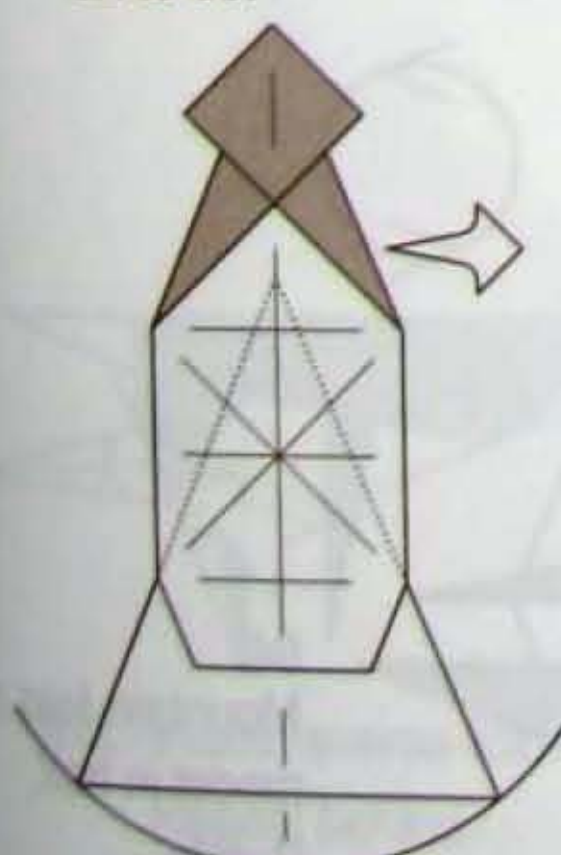

76. Scale change.

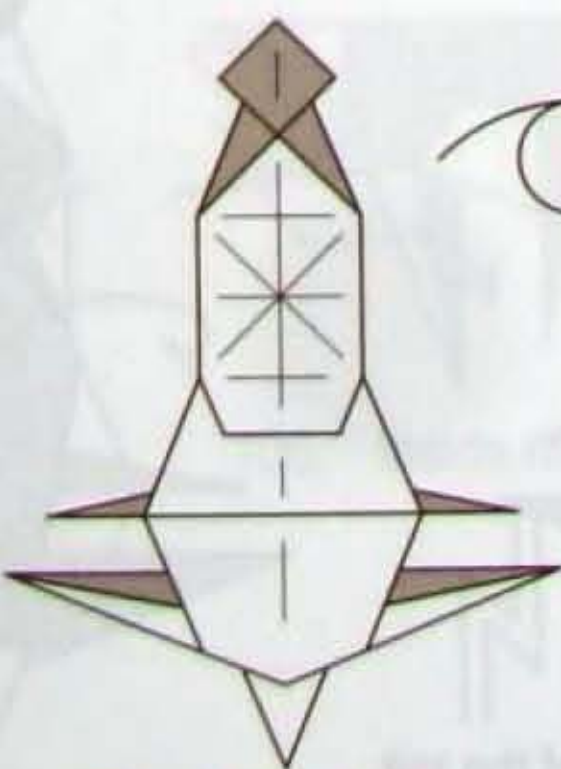

77. Turn over.

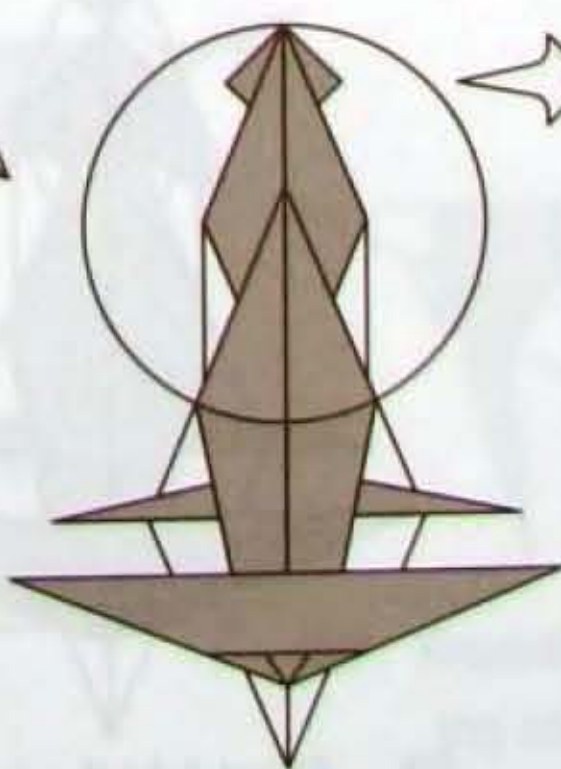

78. Enlarge.

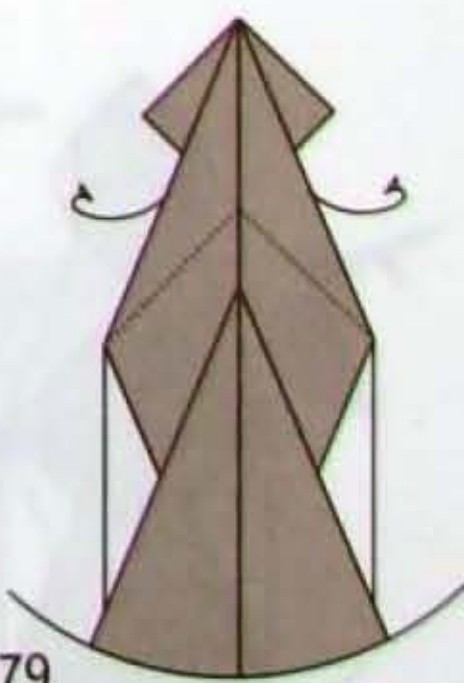

79. Bring the raw edges to the front (wrap around).

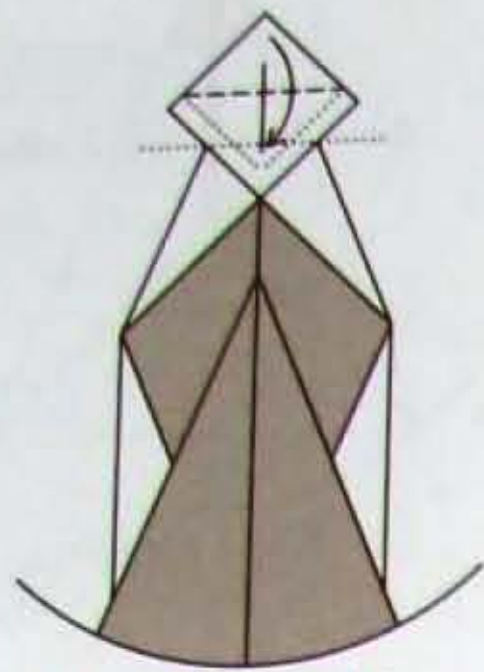

80. Valley-fold.

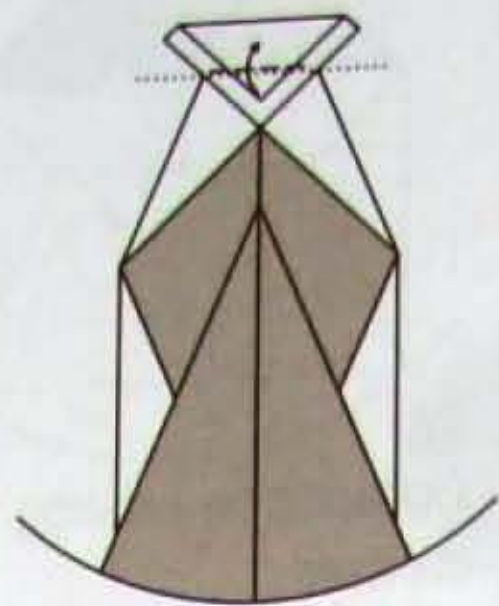

81. Valley-fold.

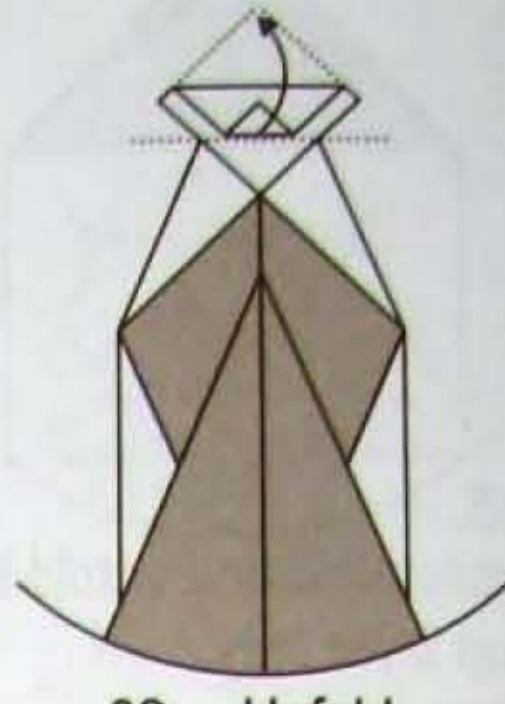

82. Unfold.



83. Open-sink in and out.

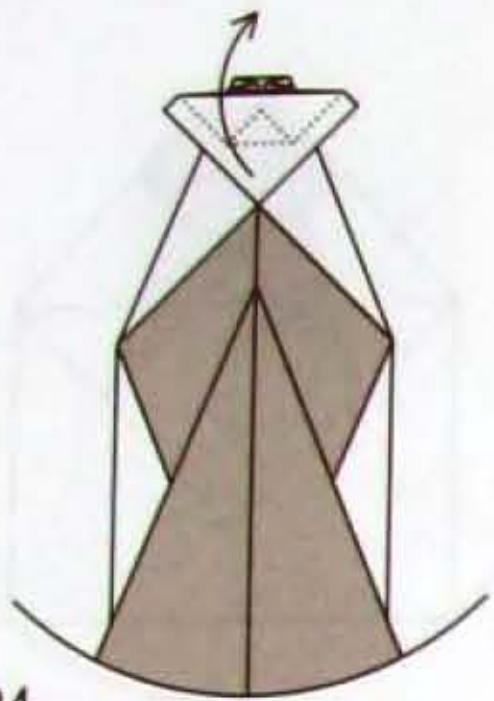

84. Valley-fold the raw corner up.

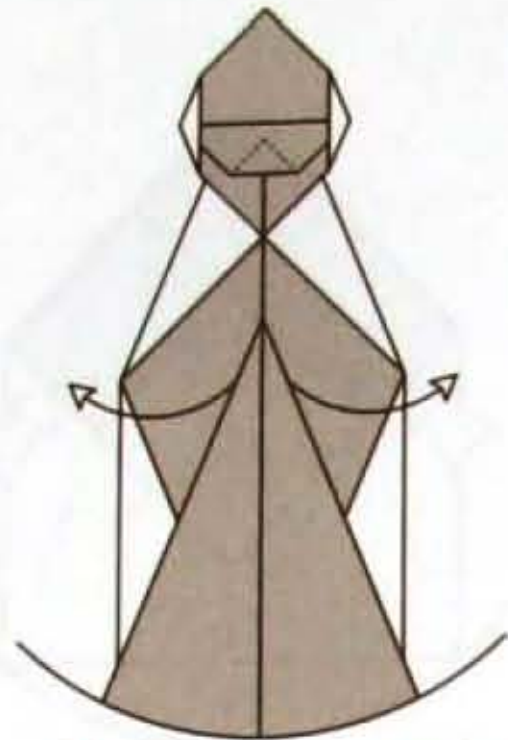

85. Unfold the raw edges totally from inside the "horn" flaps.

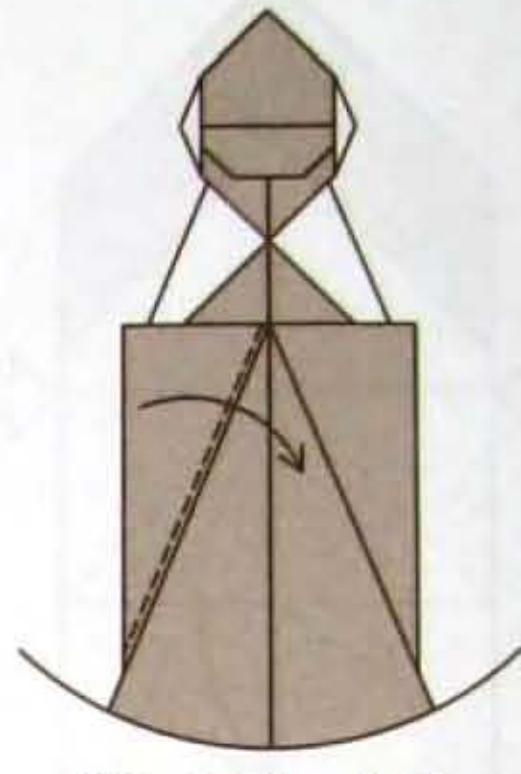

86. Valley-fold.

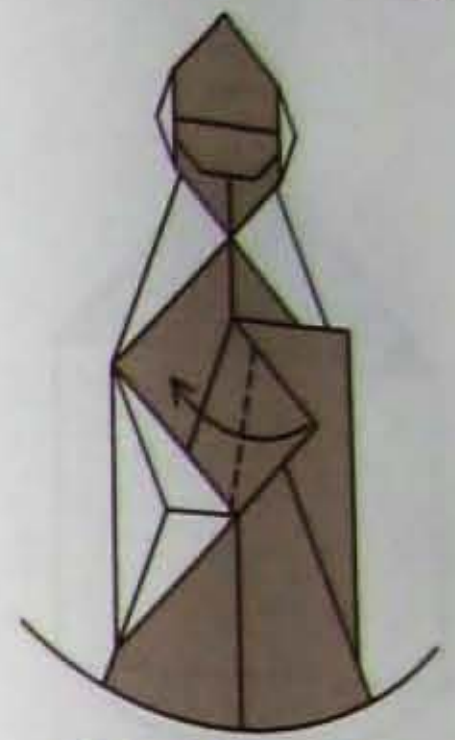

87. Valley-fold.

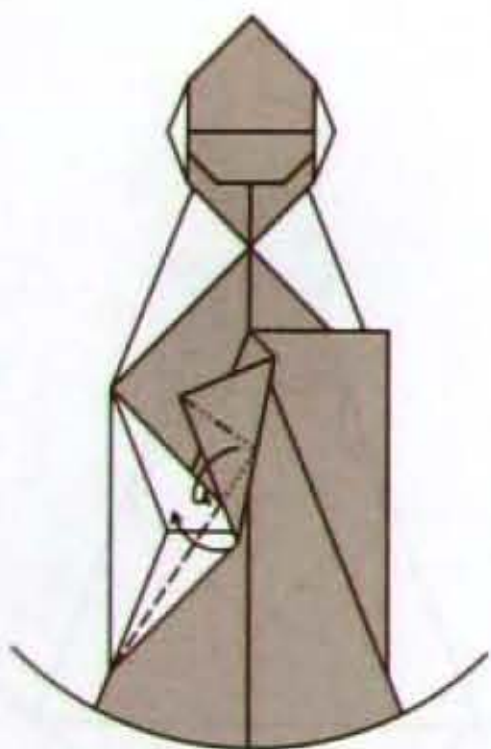

88. Swivel-fold.

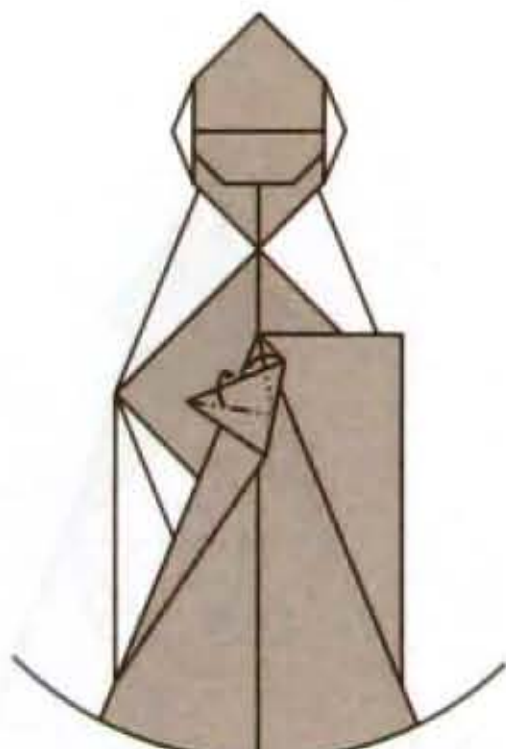

89. Swivel-fold.

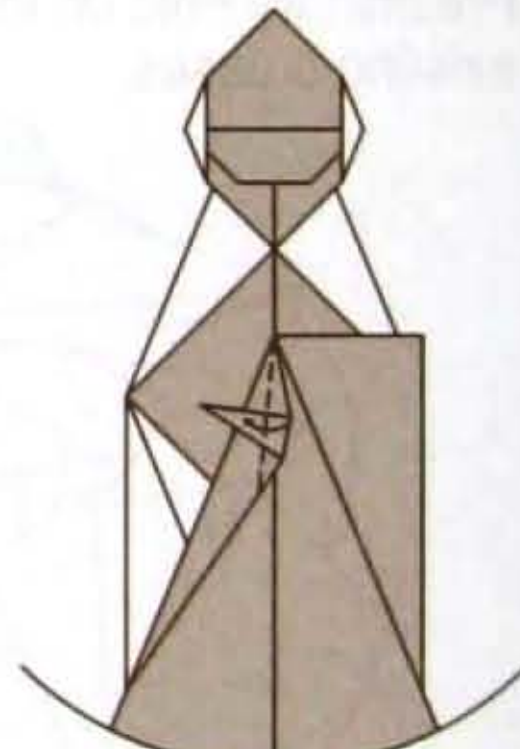

90. Valley-fold.

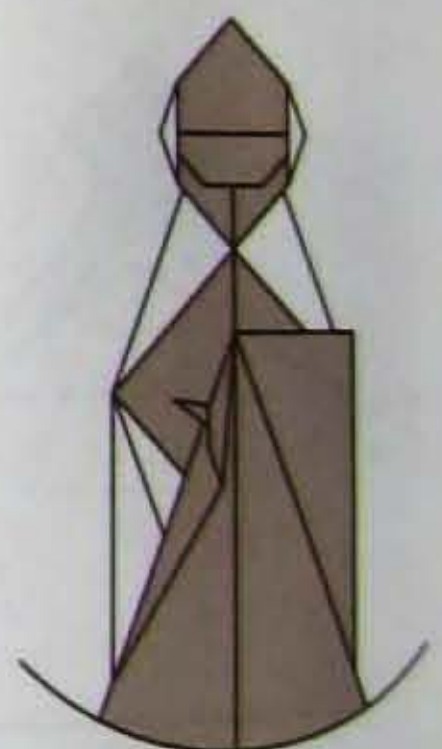

91. Repeat steps 86 to 90 on the right.

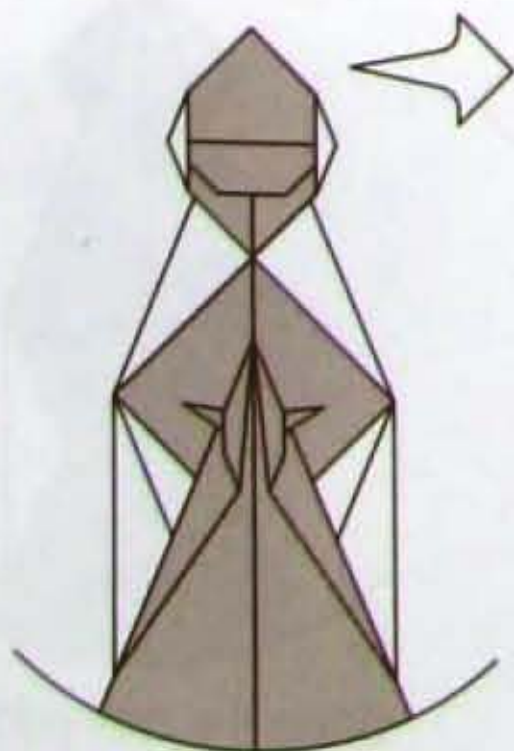

92. Scale change.

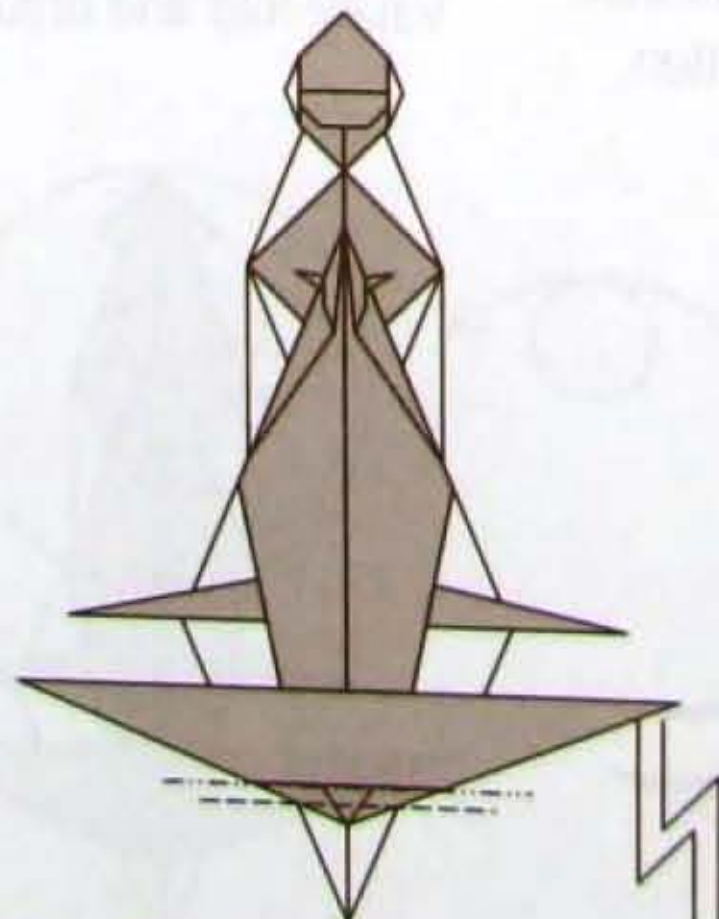

93. Pleat-fold the layers of the tail.

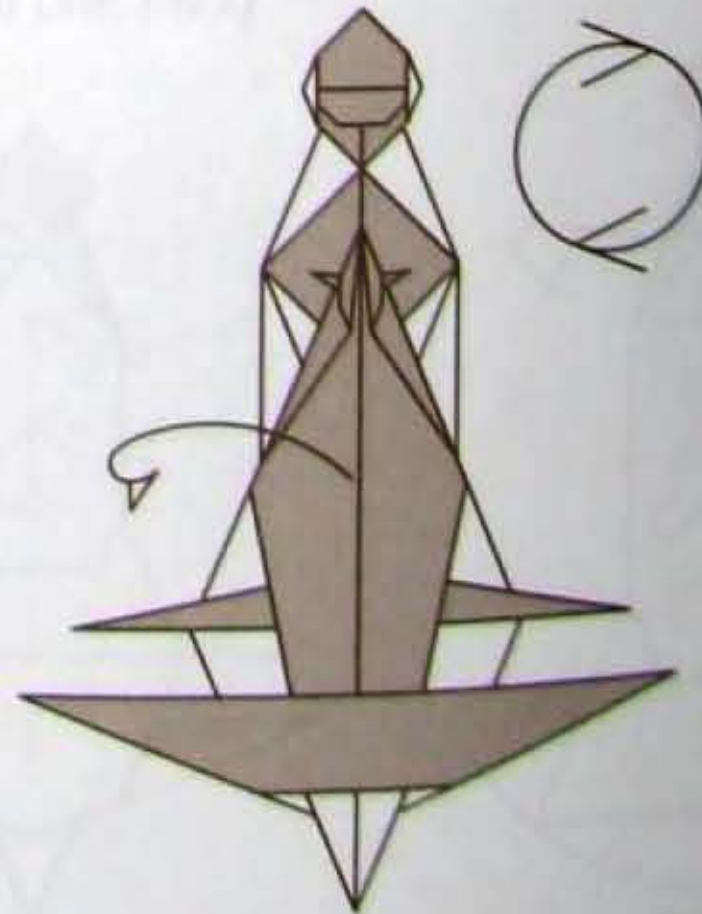

94. Mountain-fold the model in half. Rotate.

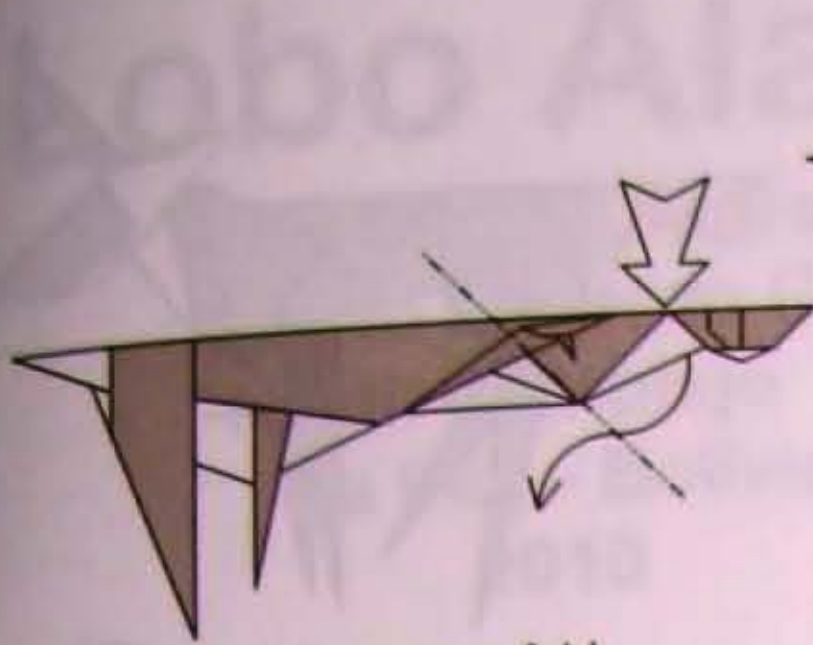

95. Inside reverse-fold.
Enlarge.

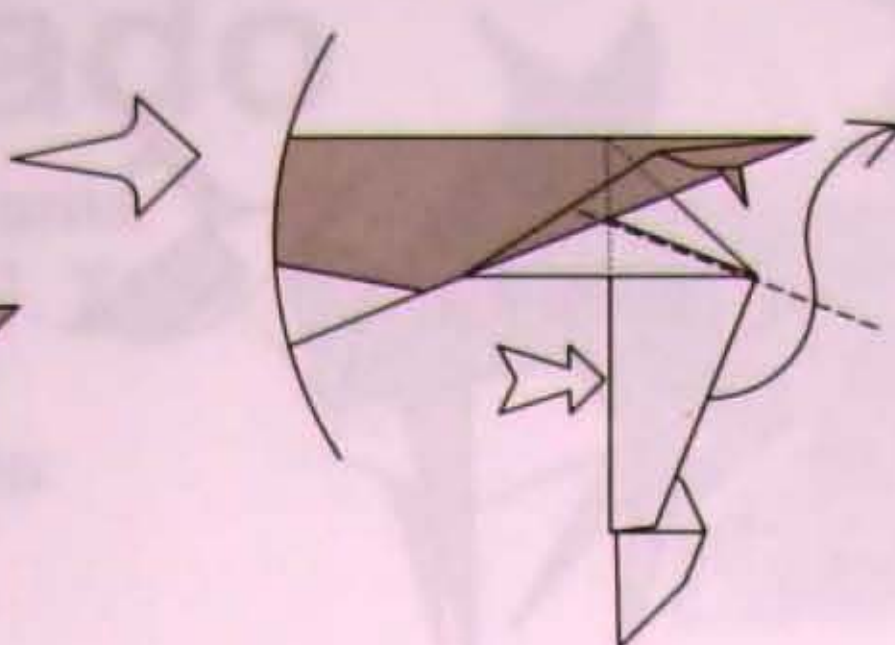

96. Inside reverse-fold.

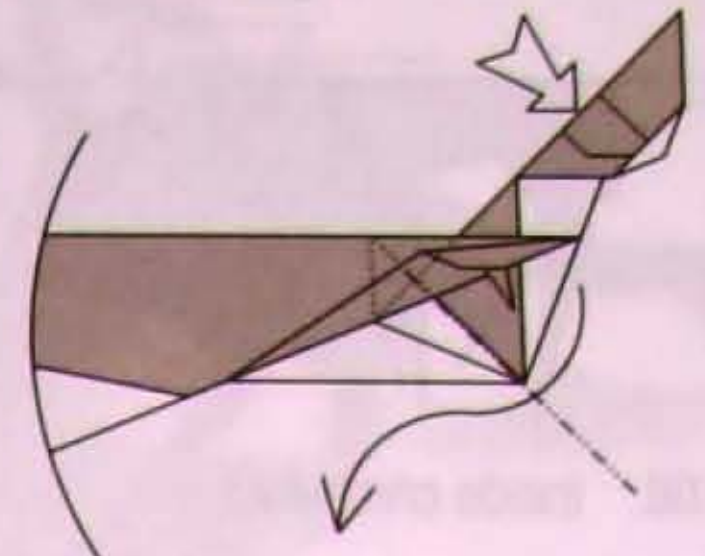

97. Inside reverse-fold.

Japão Burajirujin

www.japaoburajirujin.blogspot.com

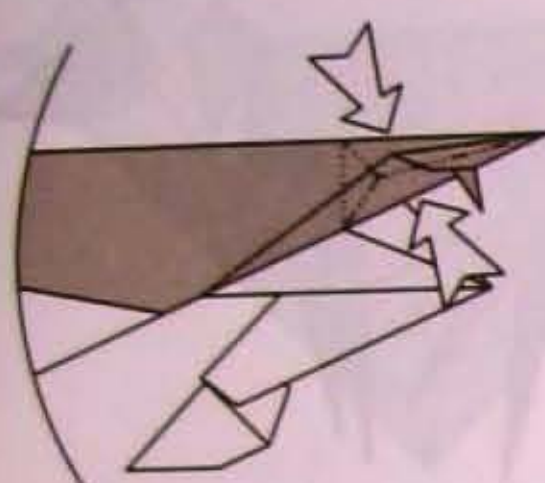

98. Pinch to thin the "horns".

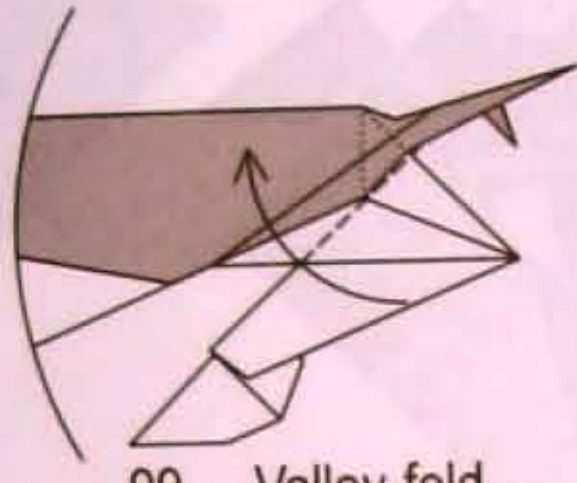

99. Valley-fold.
Repeat behind.

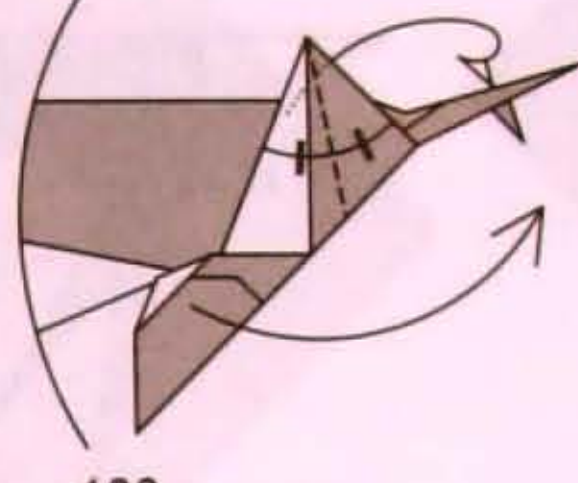

100. Outside reverse-fold.

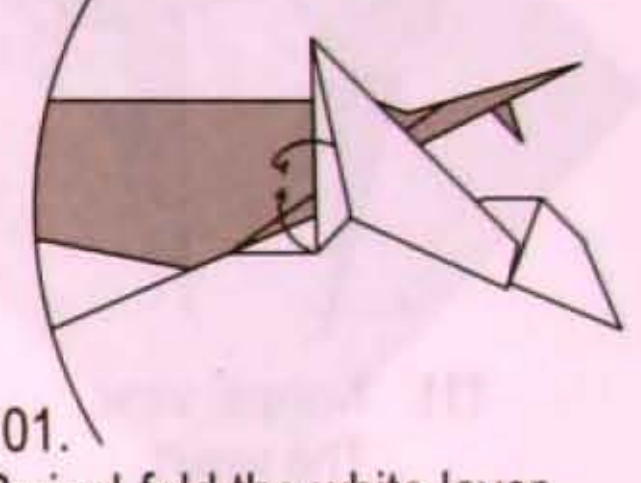

101. Swivel-fold the white layer
behind the ear.
Repeat behind.

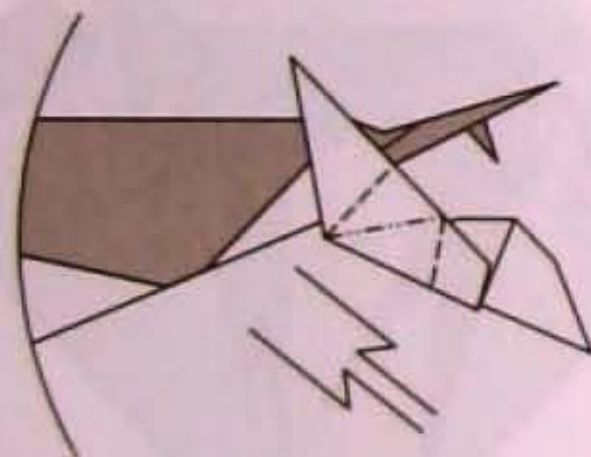

102. Wrap the head
around the neck.

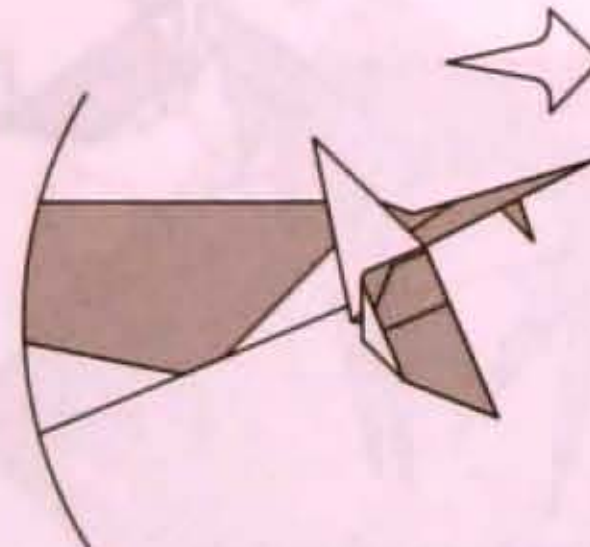

103. Scale change.

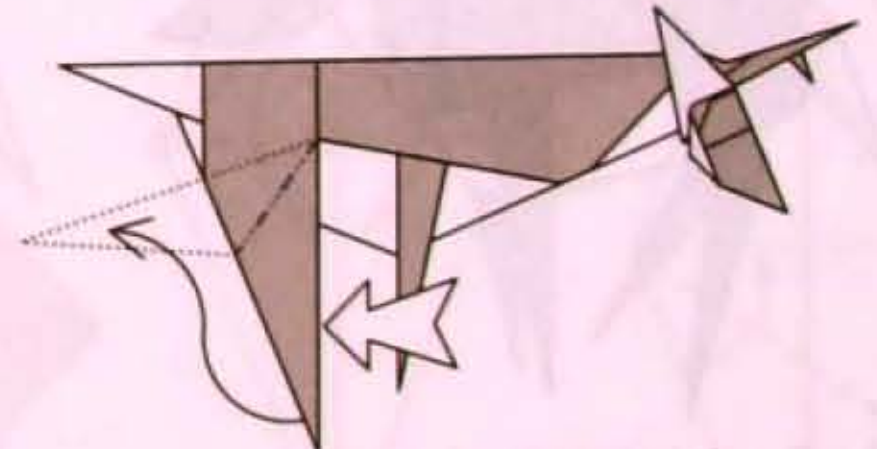

104. Inside reverse-fold.

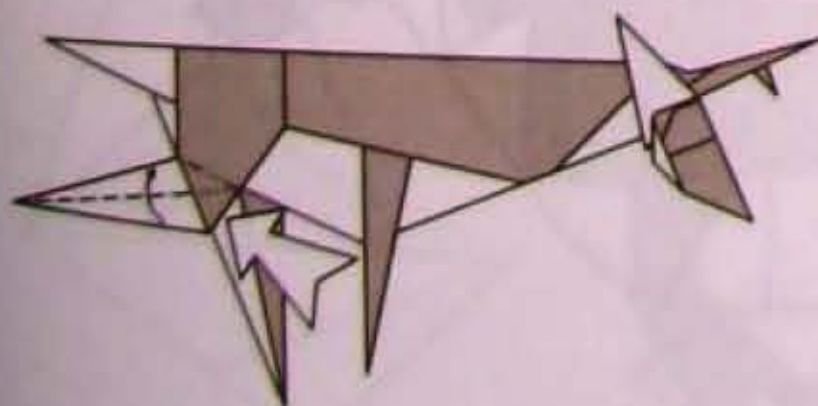

105. Inside reverse-fold.
Repeat behind.

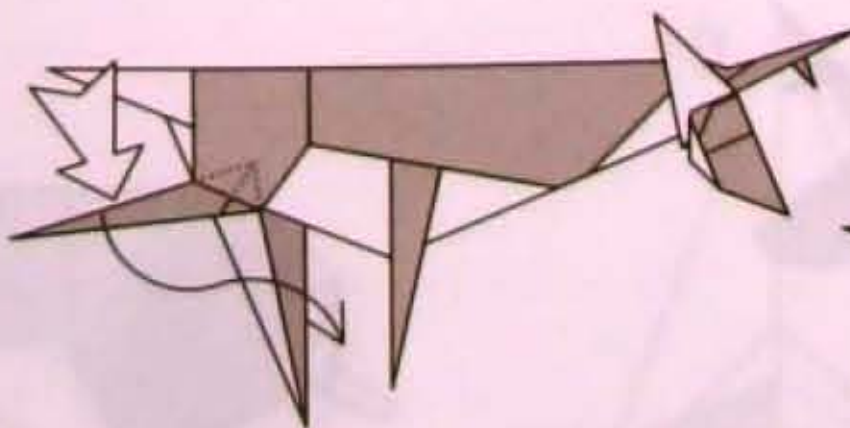

106. Inside reverse-fold.

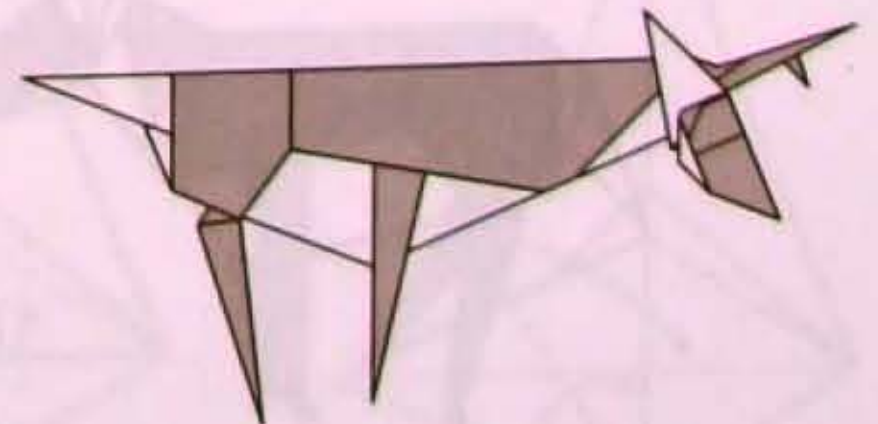

107. Repeat steps 104 to 106 on
the other hind leg.

nd out.

b

02

86 to 90

n-fold the
half.

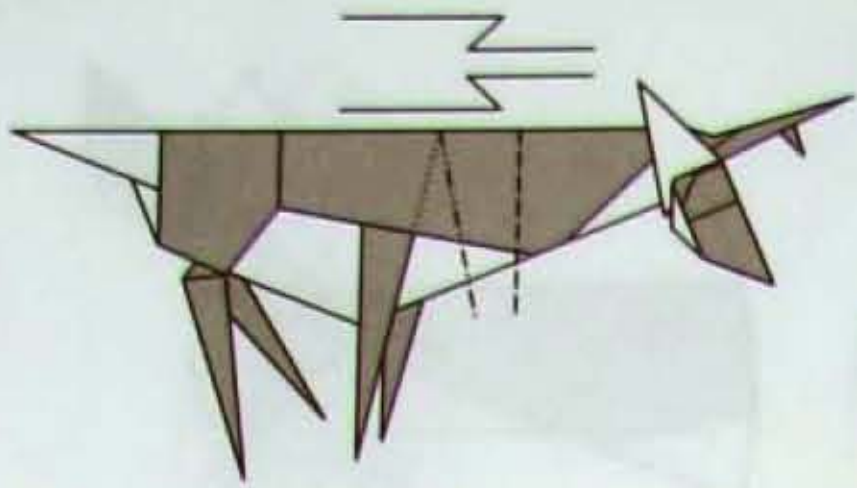

108. Inside crimp-fold.

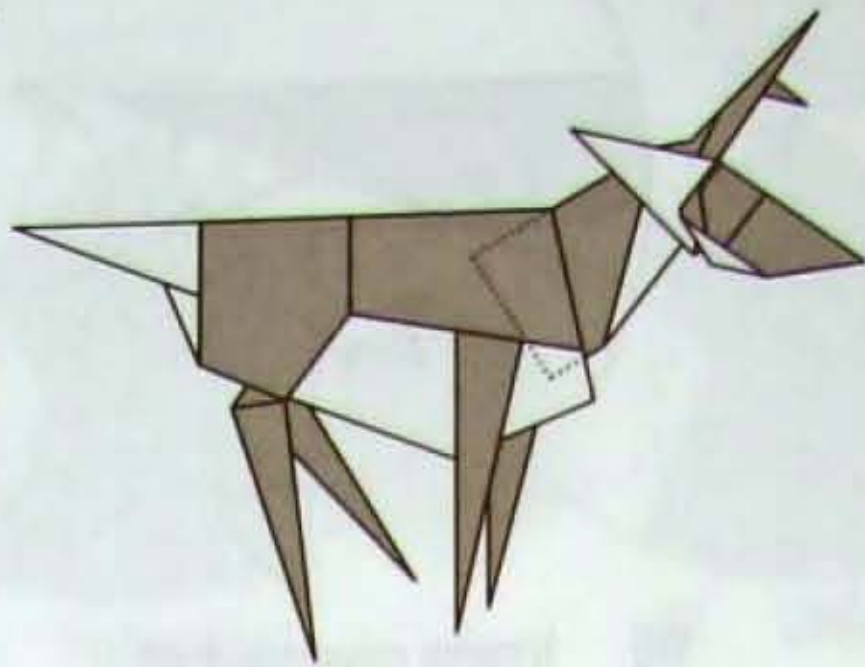

109. Next view will show the internal layers.

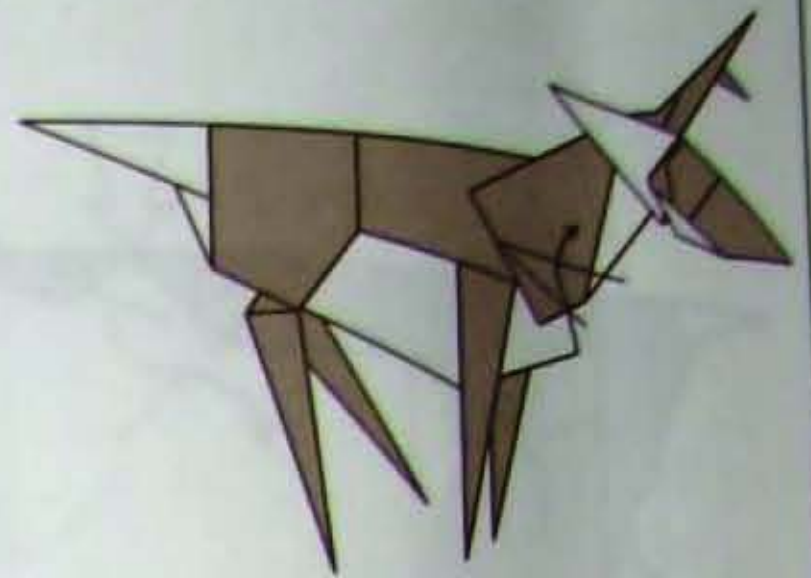

110. X-Ray view.
Swivel-fold the edge.

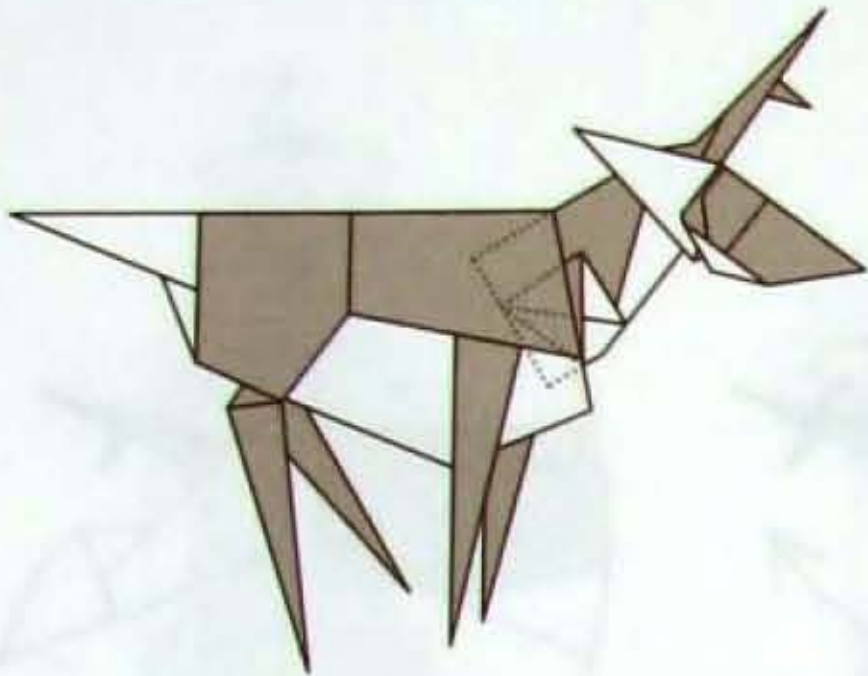

111. Normal view.
The result.

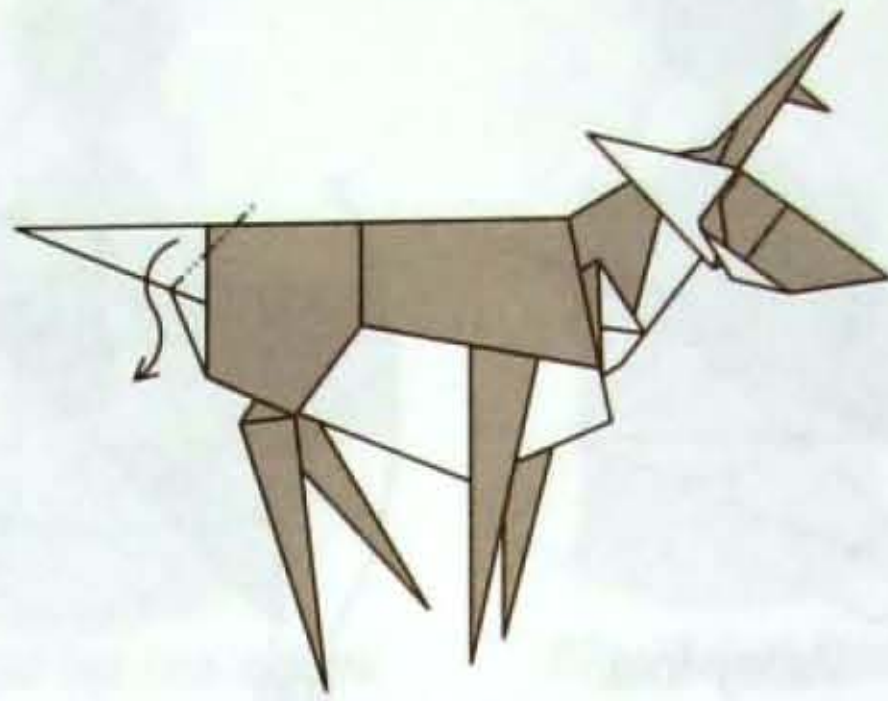

112. Inside reverse-fold.



113. Mountain-folds.
Repeat behind.



114. Squash-fold to shape
the ears.



115. Inside reverse-fold.



Crimp-fold the hooves.

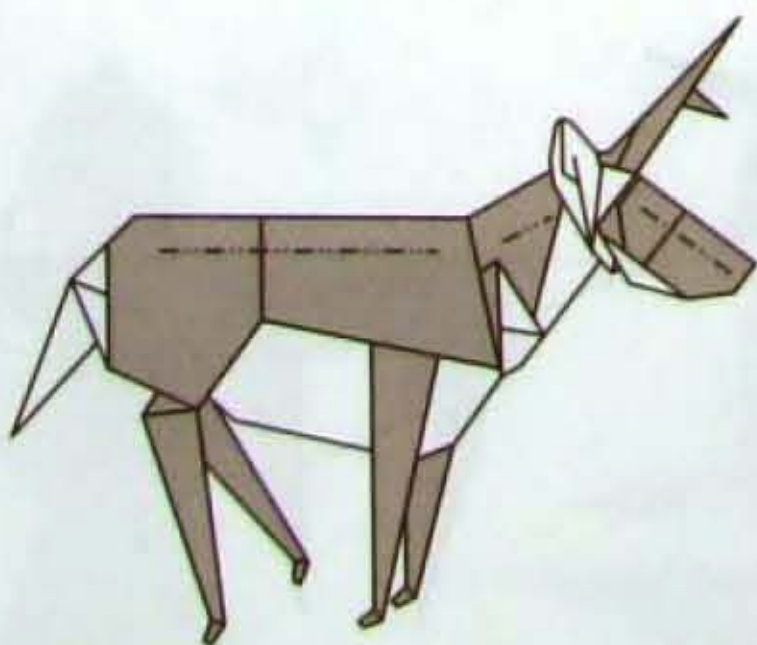

116. Curl the "horns".
Shape the legs and body to
your own taste.

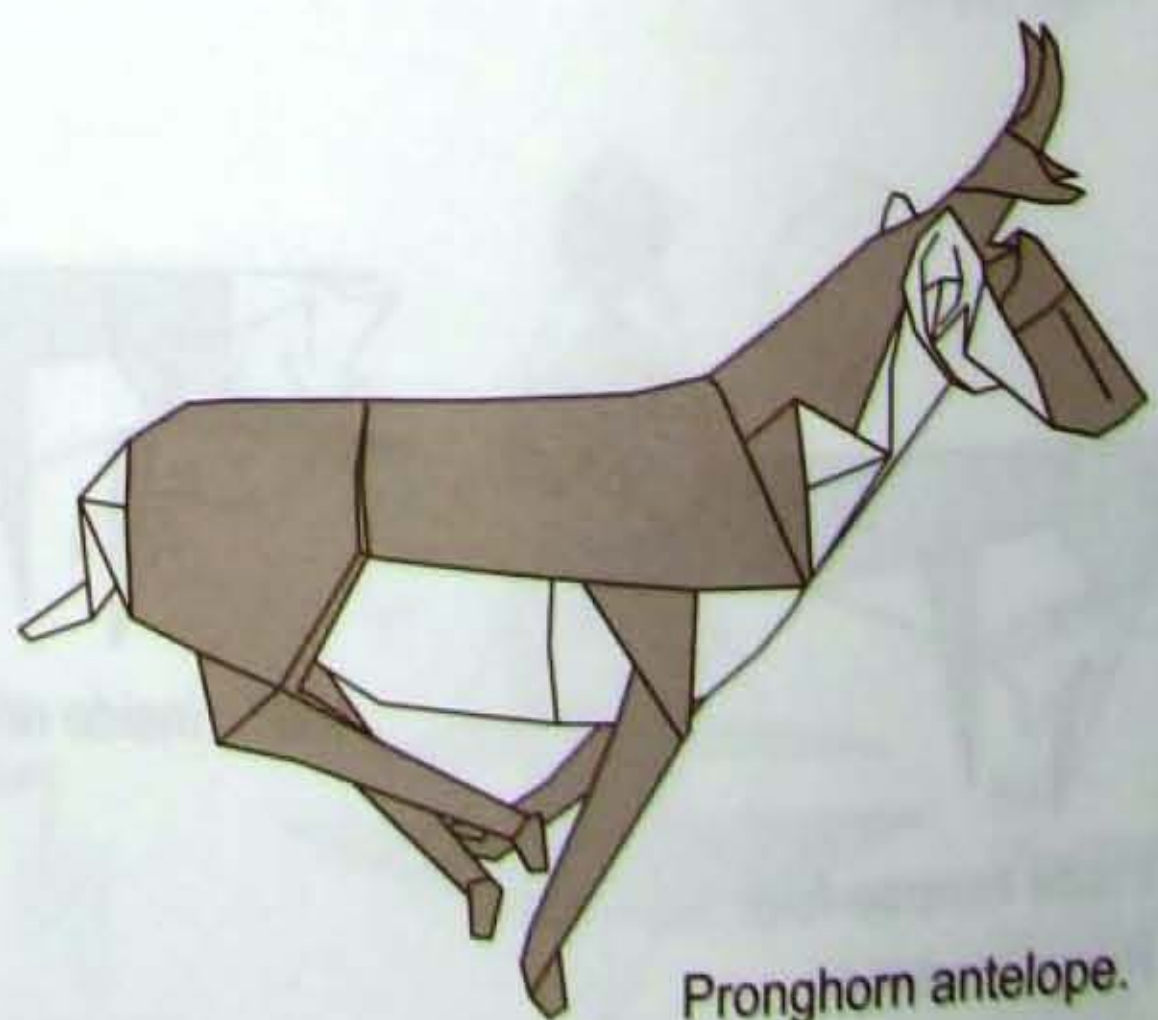

Pronghorn antelope.

Lobo Alado

- Modelo & Diagrama
Julio Eduardo C. T.
- Nivel: Complejo
La Paz - Bolivia
2010

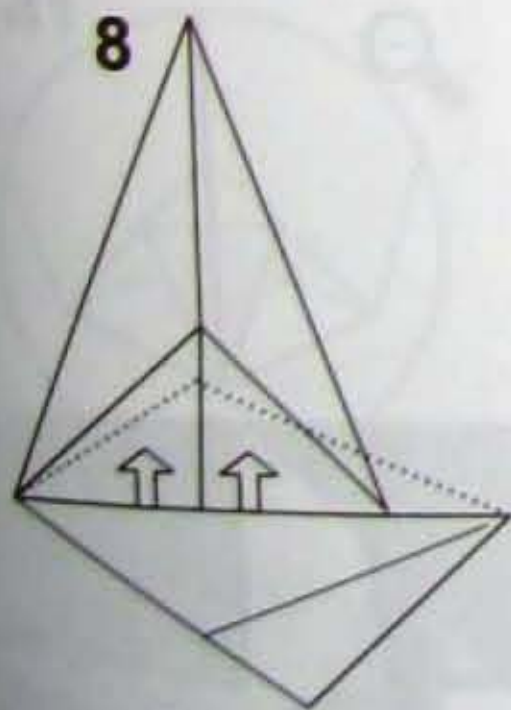
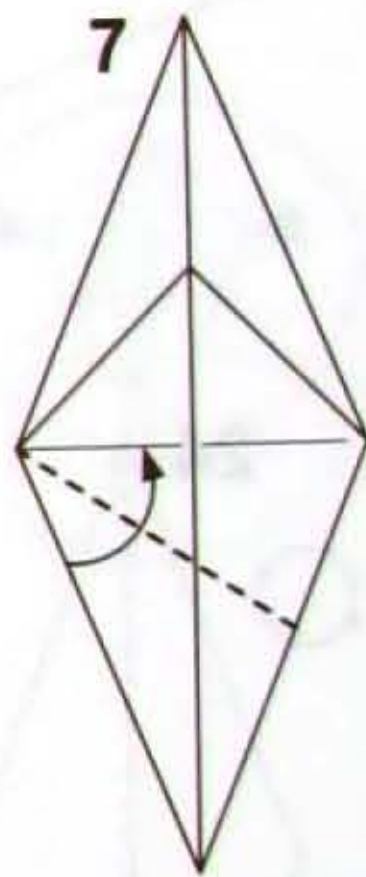
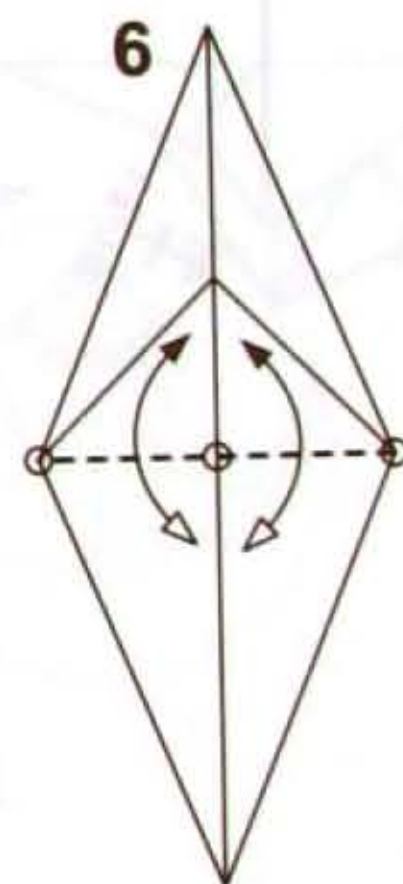
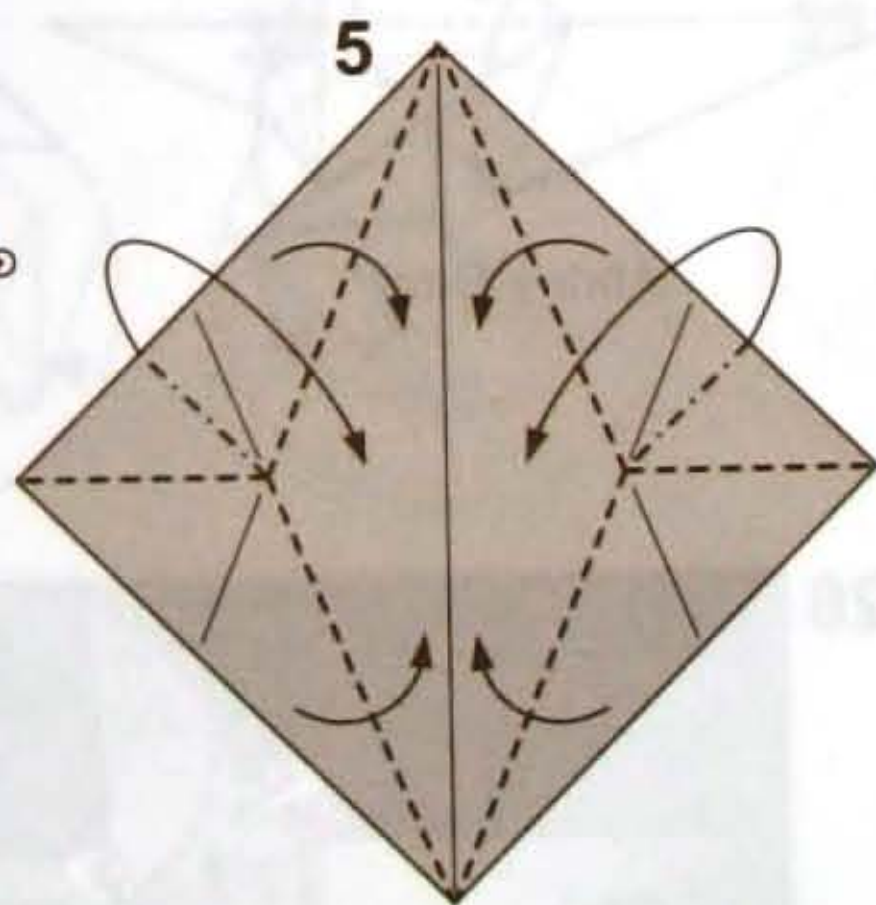
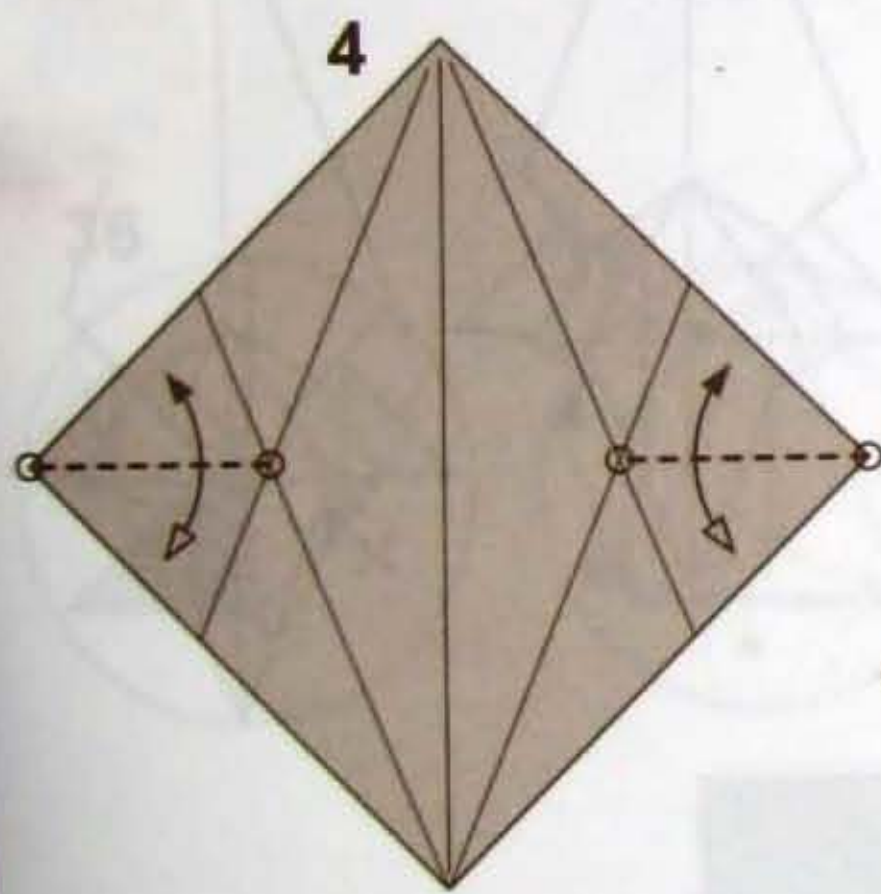
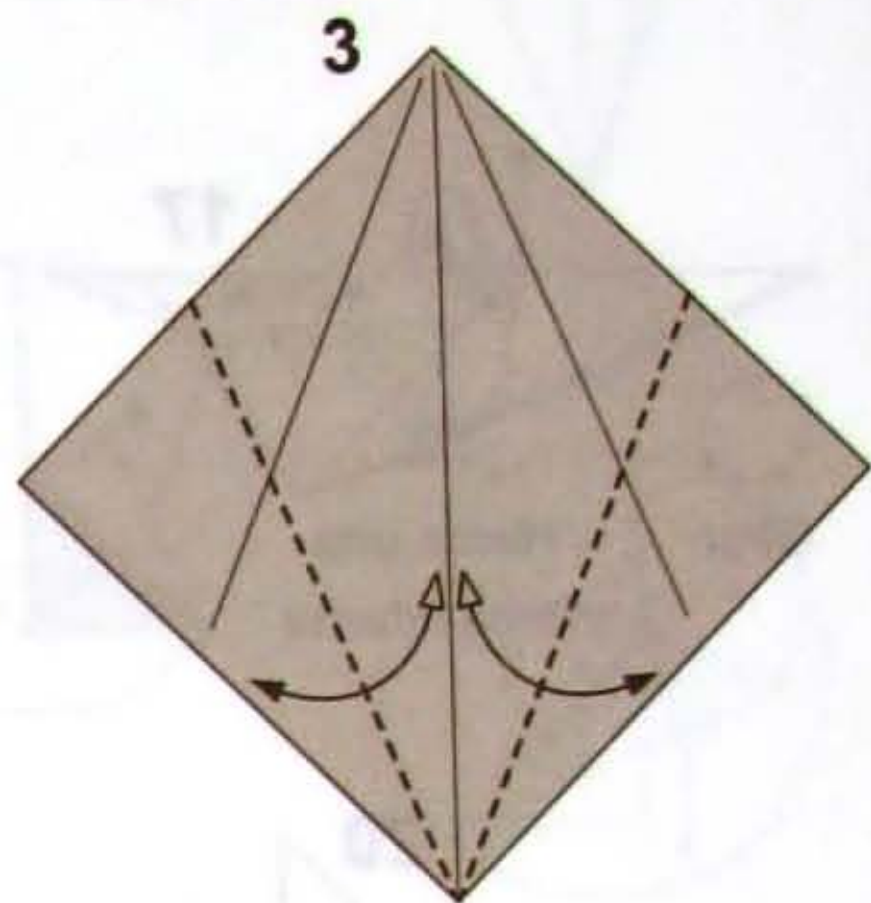
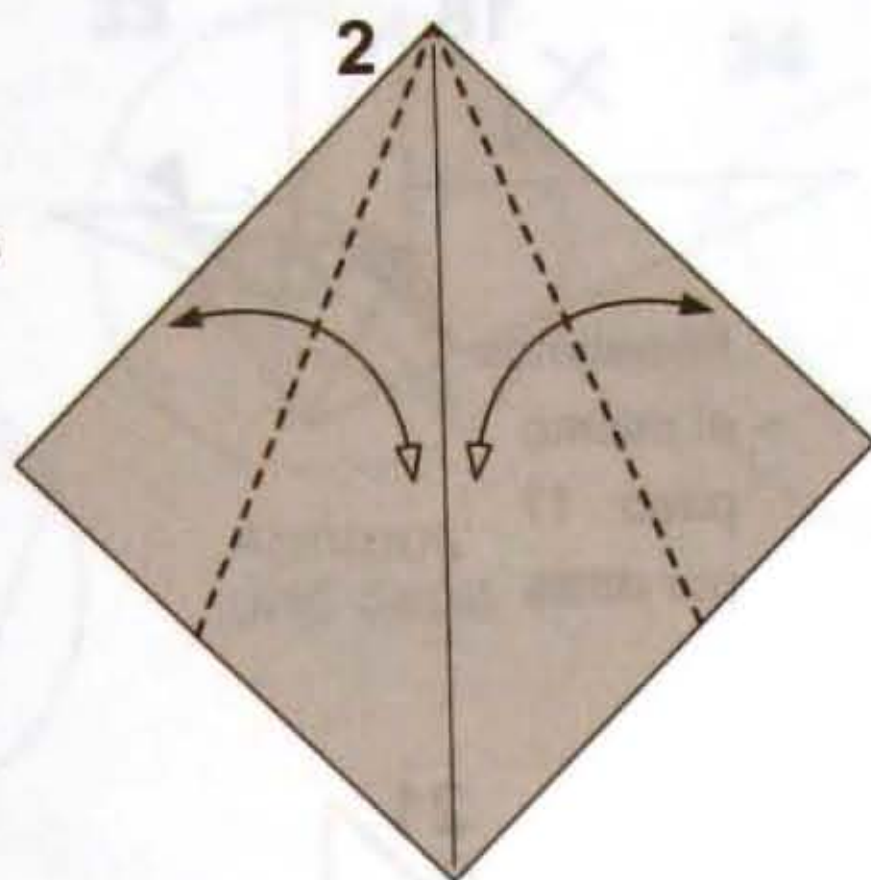
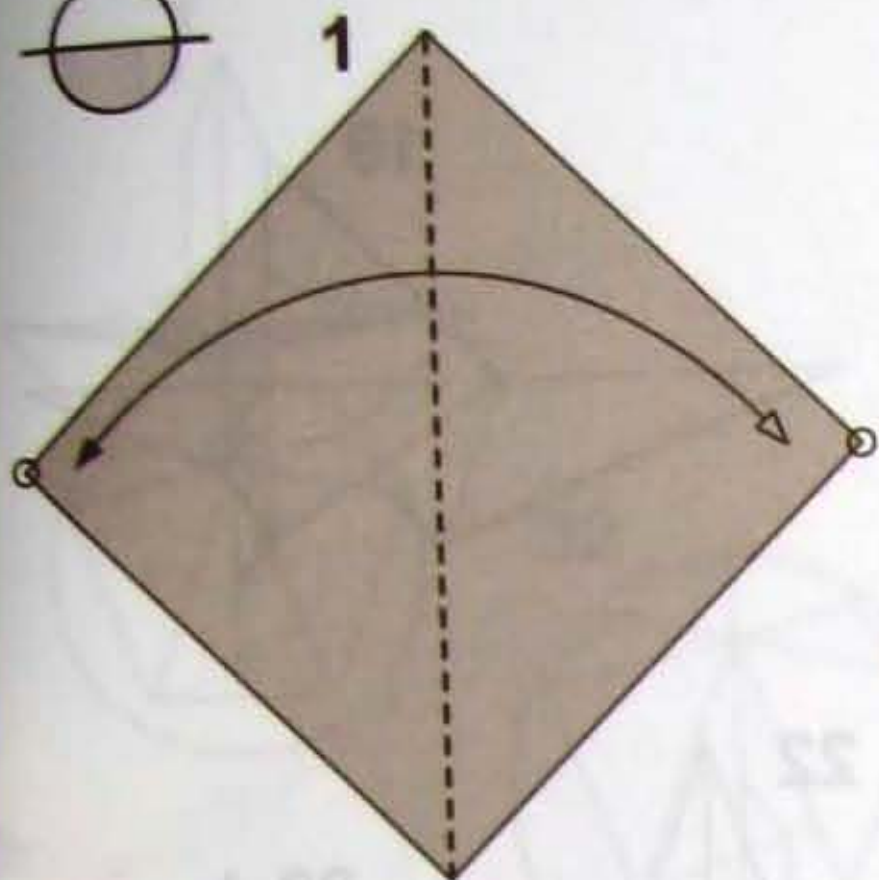
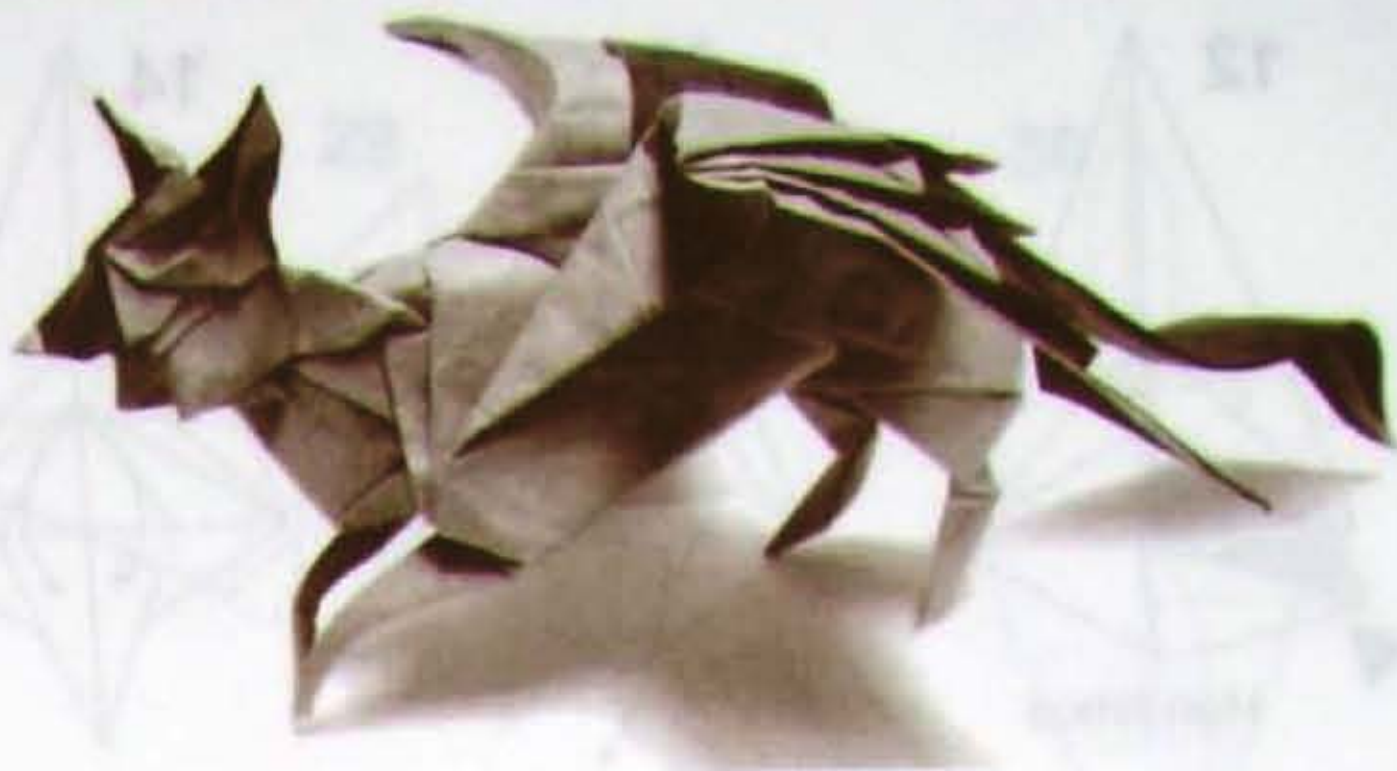

Sacar la capa que
esta por dentro

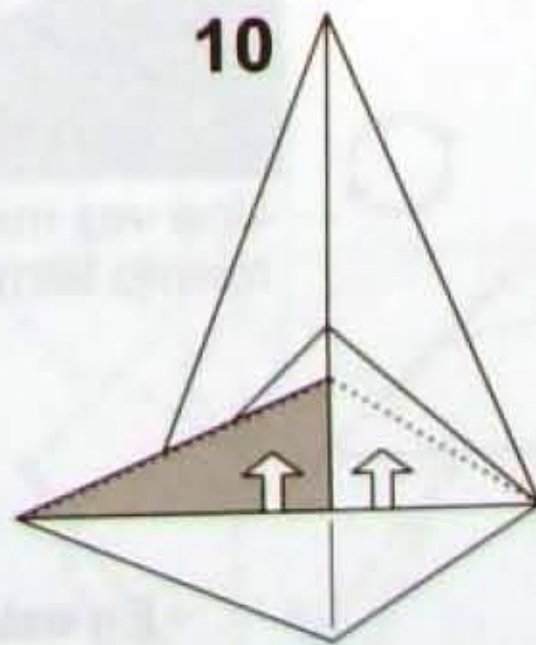
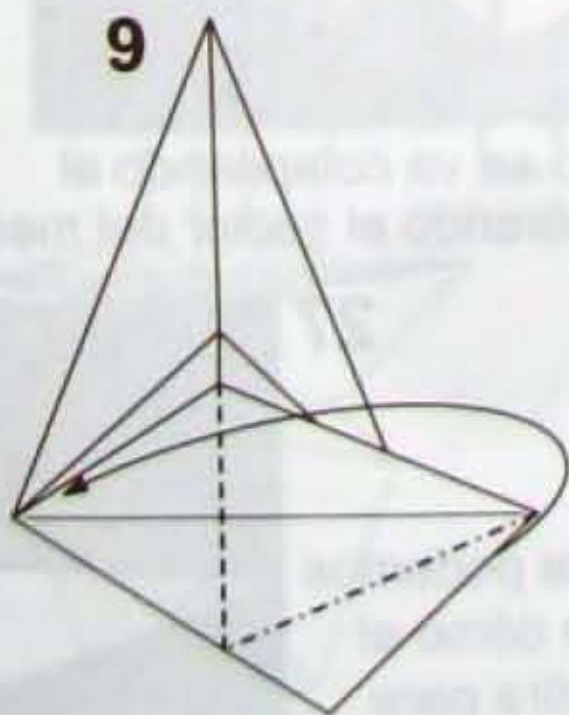

Sacar la capa que
esta por dentro

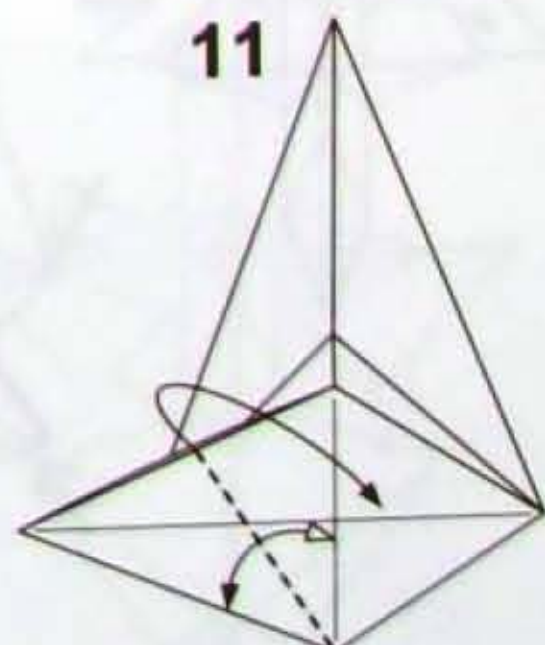

Abrimos lo
de adentro

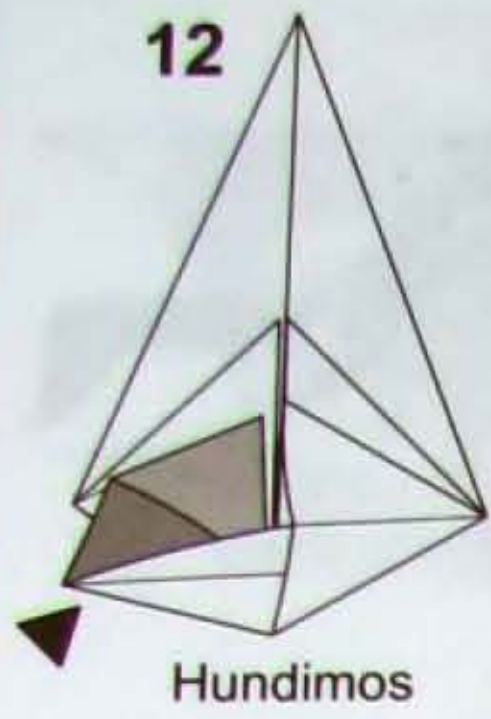

Hundimos

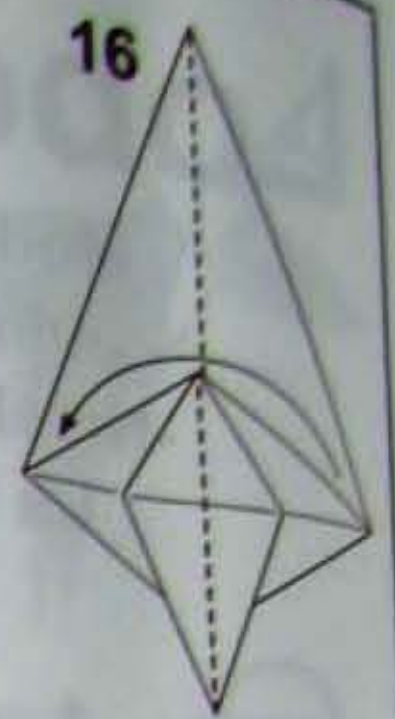
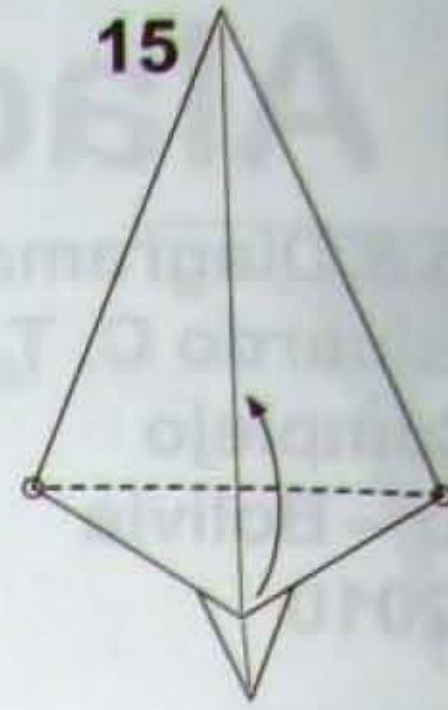
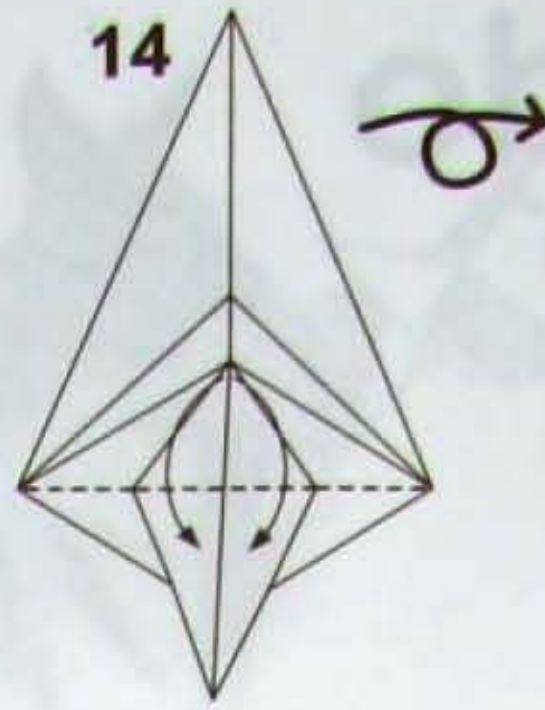
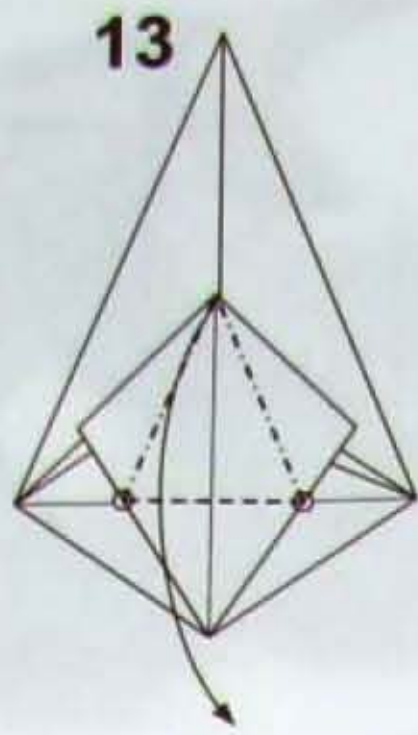

Girar

Hacer una
marca interna



Repetimos
el mismo
paso 17
por atrás

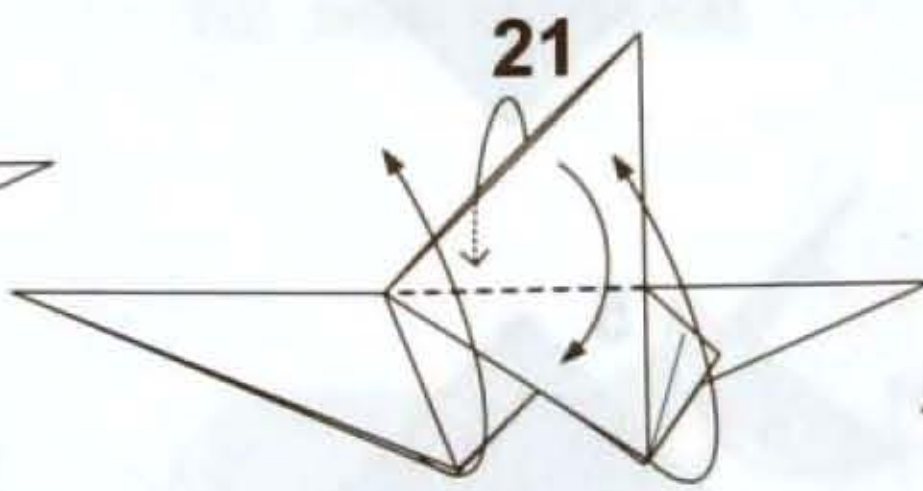
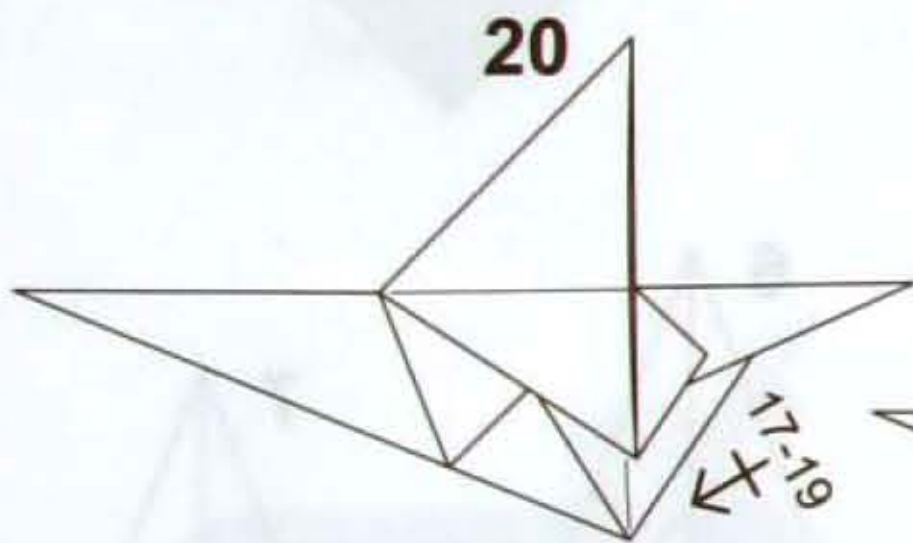
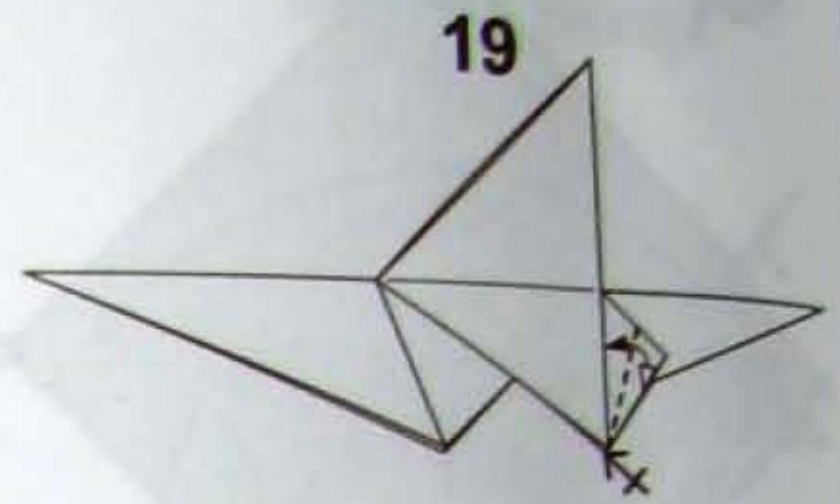

Abrir y Girar

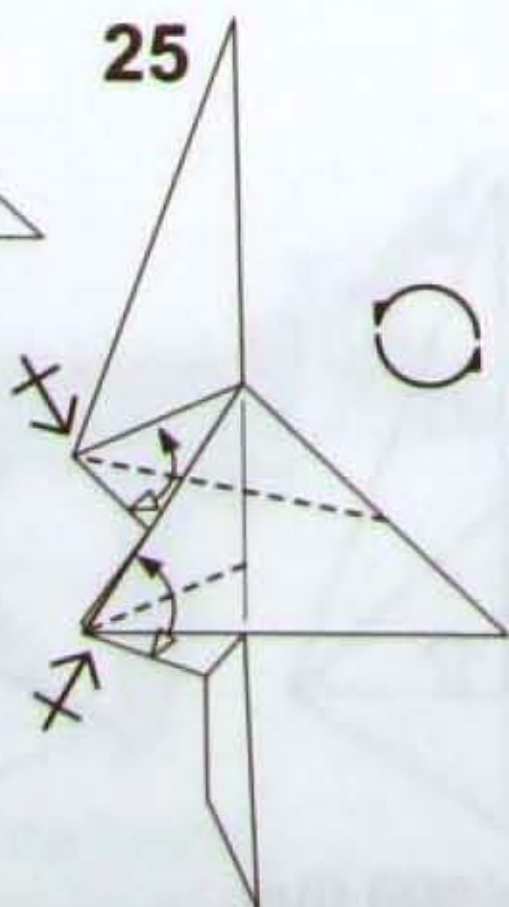
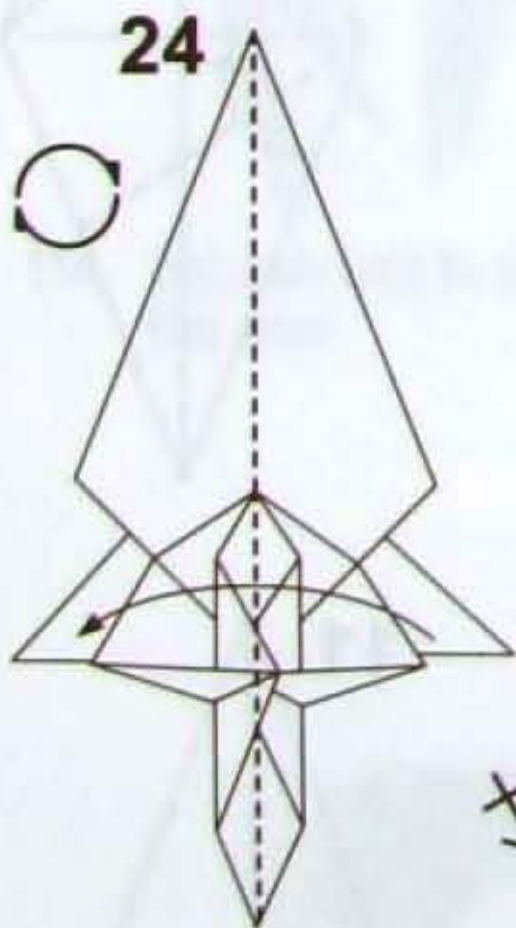
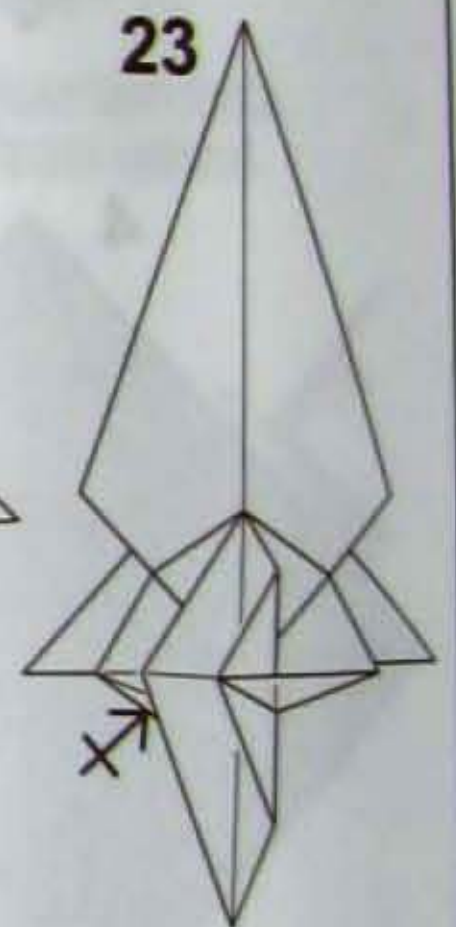
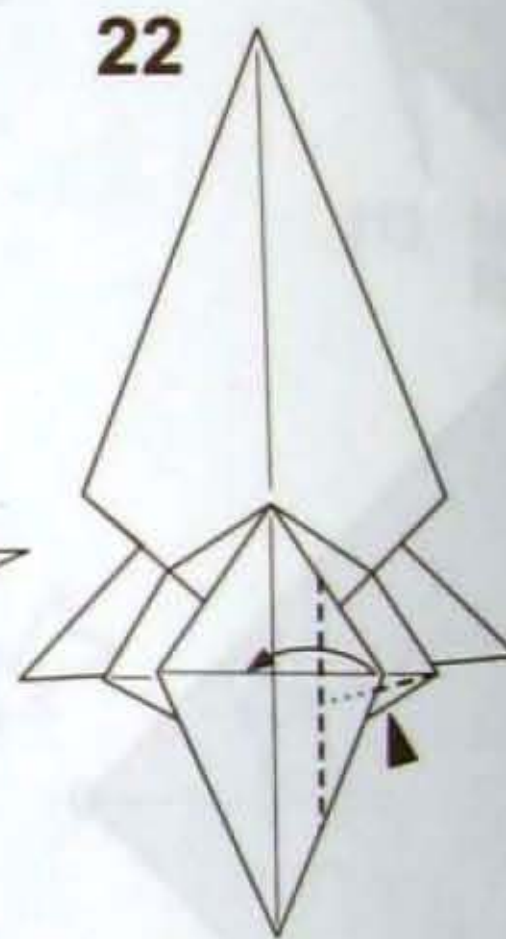

26

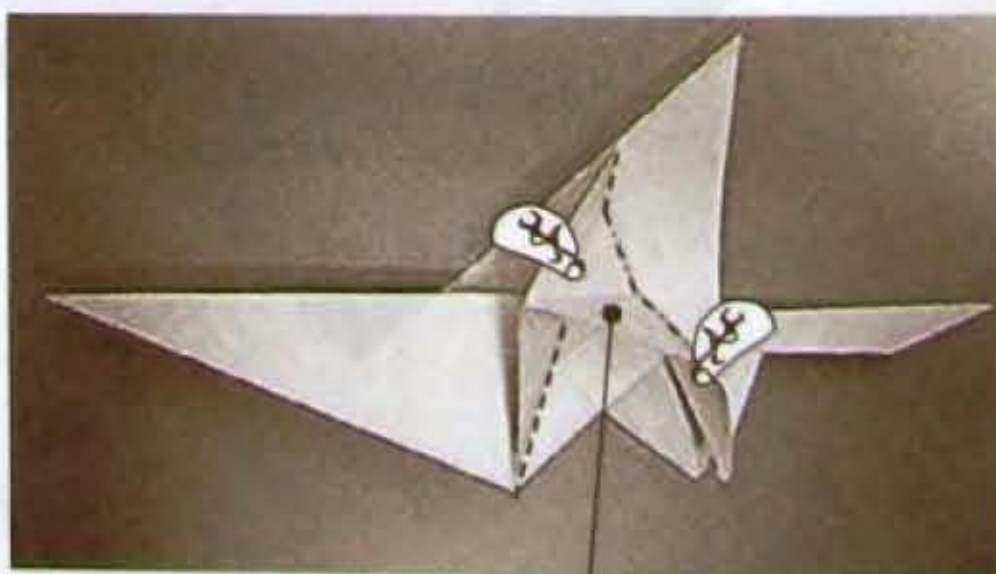

Una vez marcado se va colapsando al mismo tiempo estirando el sector del medio

27

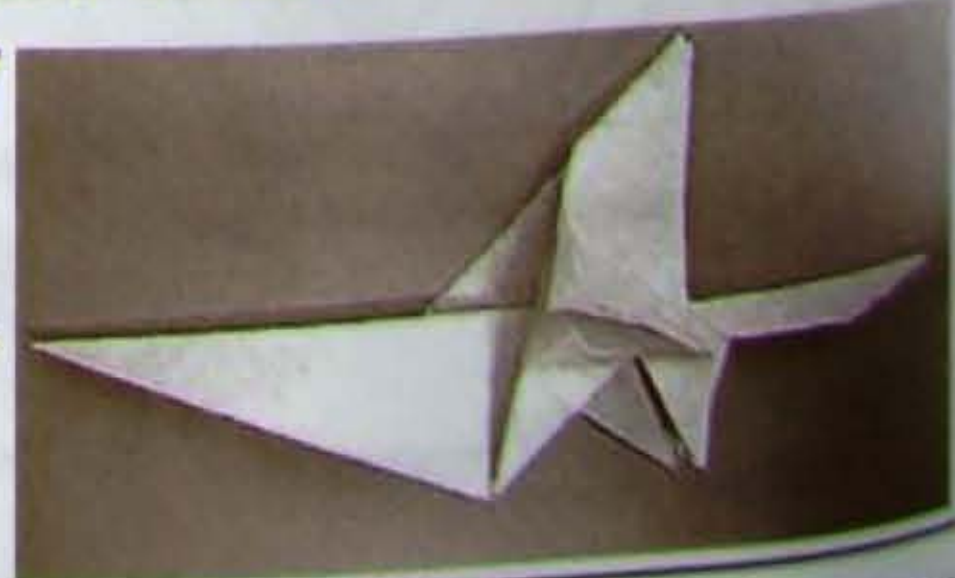

En esta parte podemos observar de cómo el centro se estira para luego ser colapsada

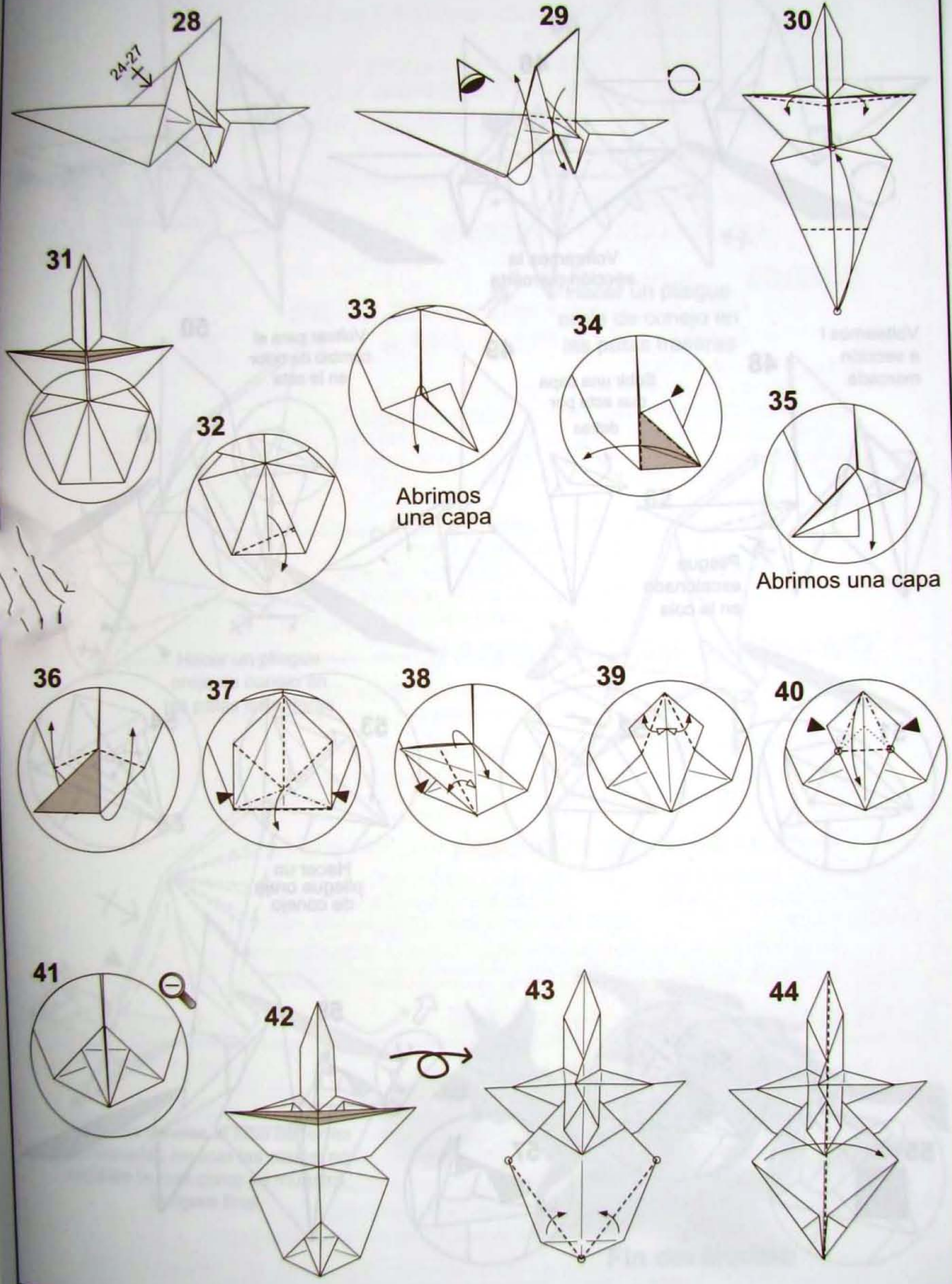

28

29

30

31

33

34

32

35

Abrimos una capa

Abrimos una capa

36

37

38

39

40

41

42

43

44

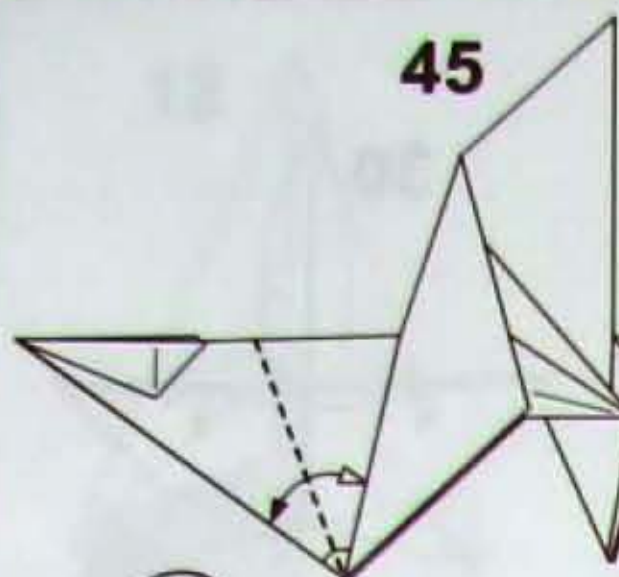

45

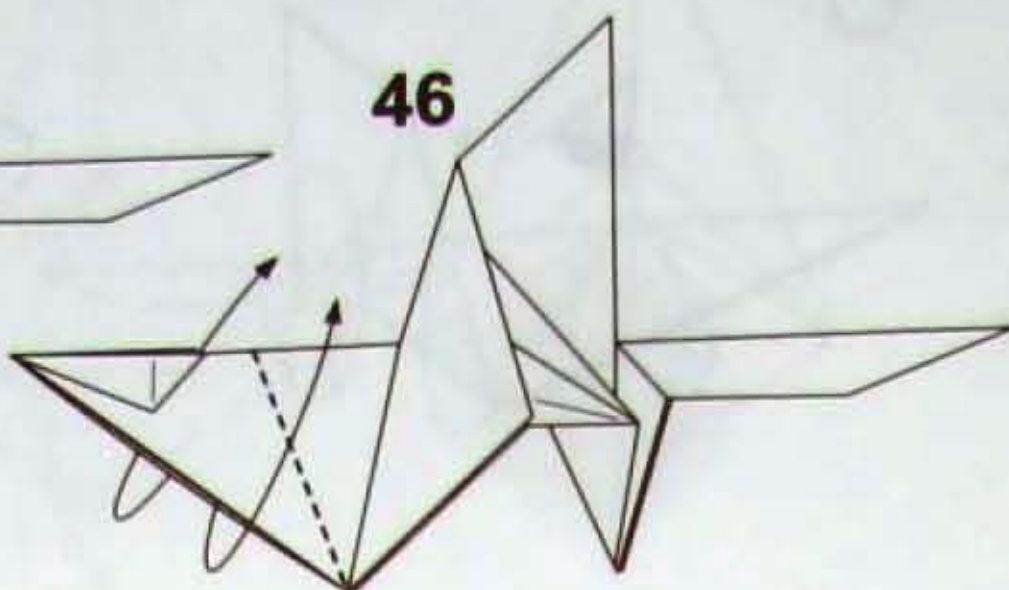

46

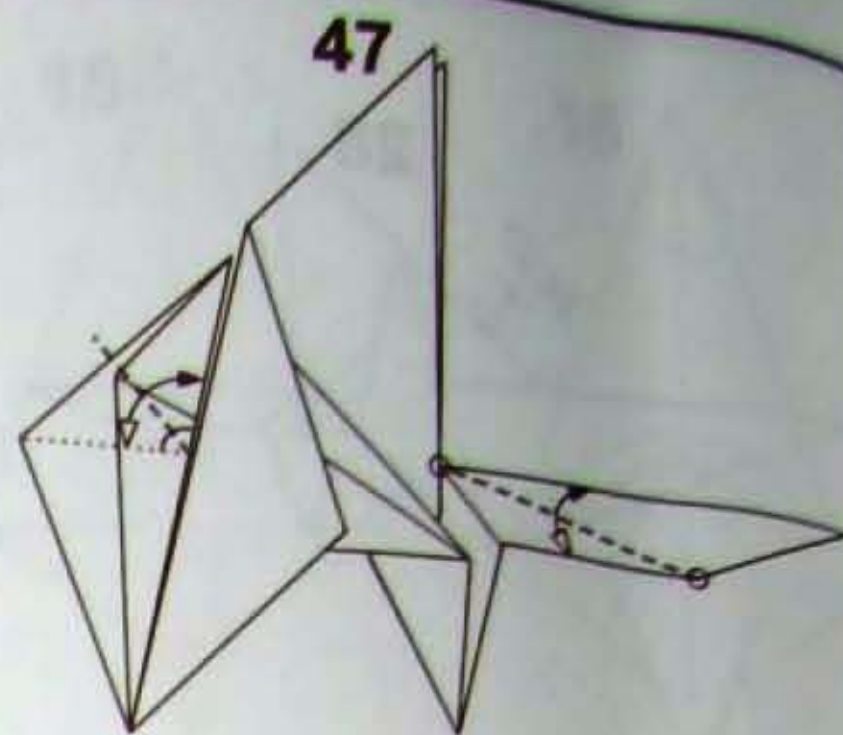

47

Volteamos la sección marcada

Volteamos l a sección marcada

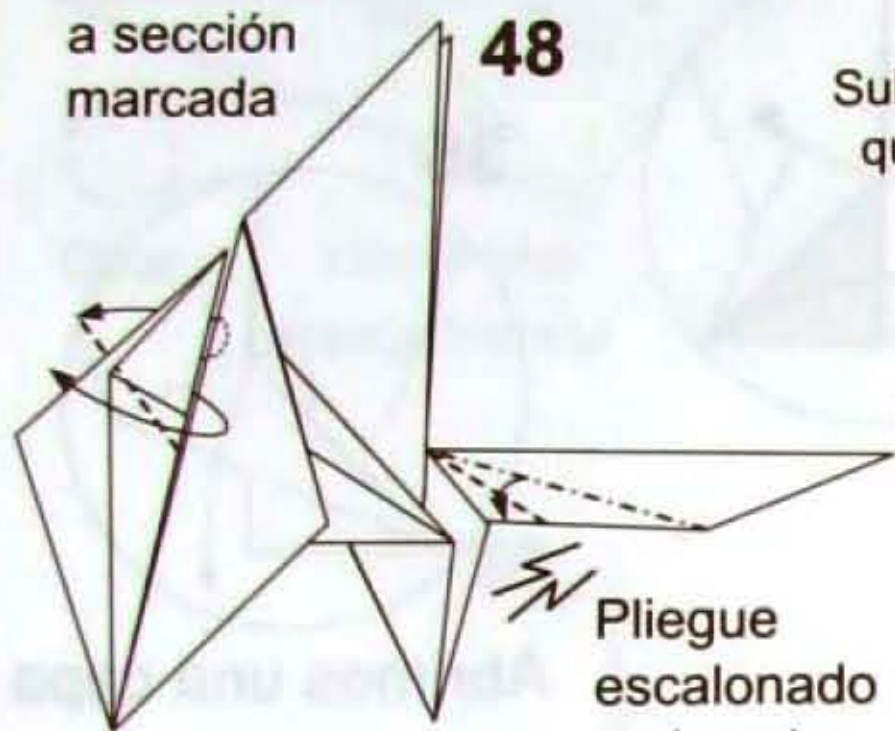

48

Subir una capa que esta por detras

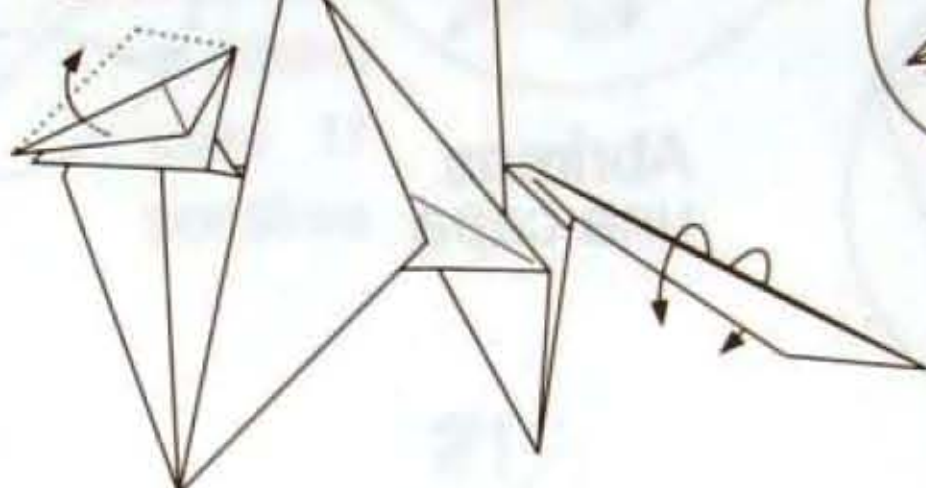

49

Voltear para el cambio de color en la cola

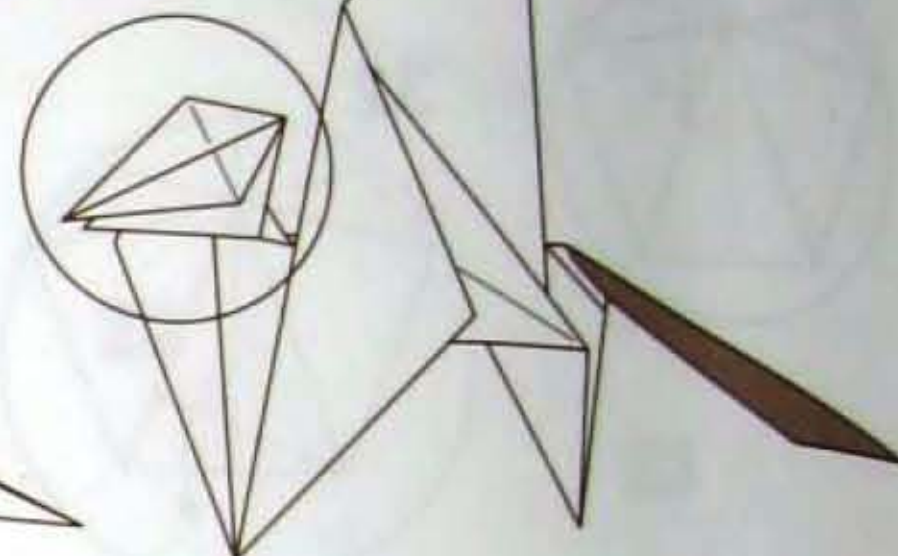

50

Pliegue escalonado en la cola

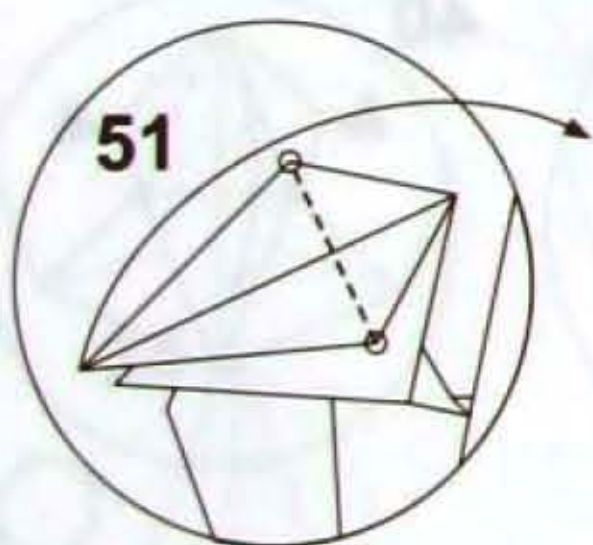

51

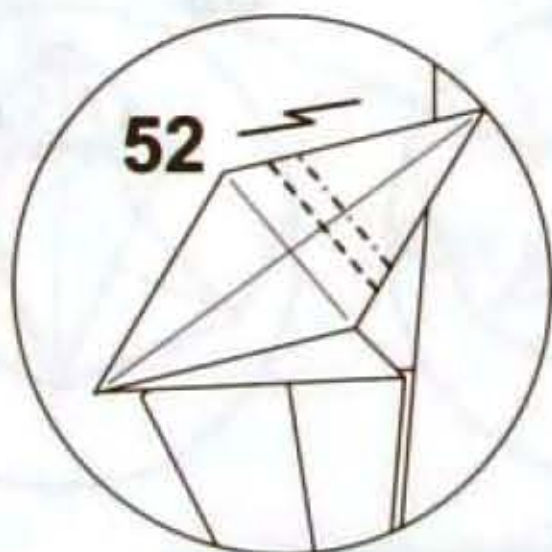

52

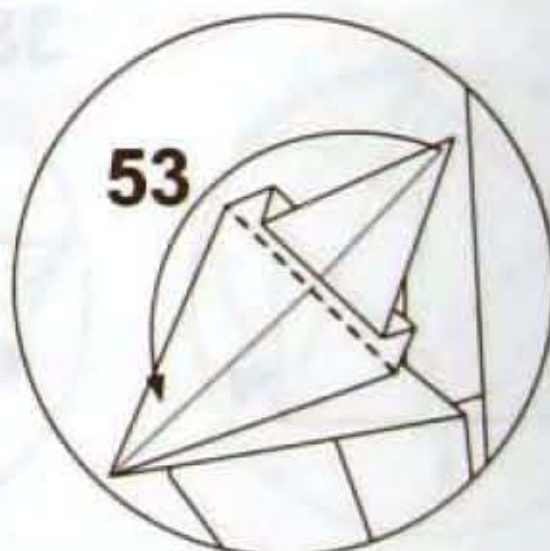

53



54

Hacer un pliegue oreja de conejo

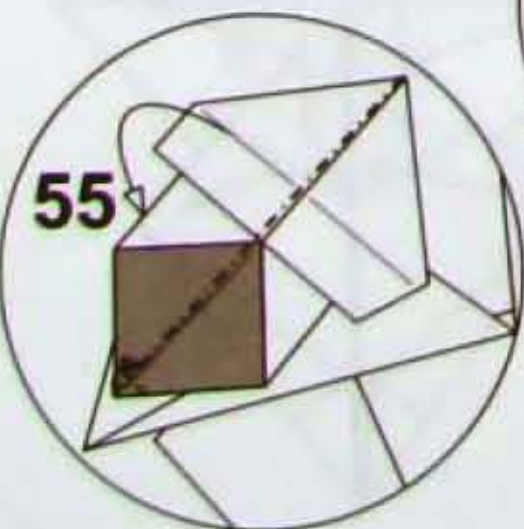

55

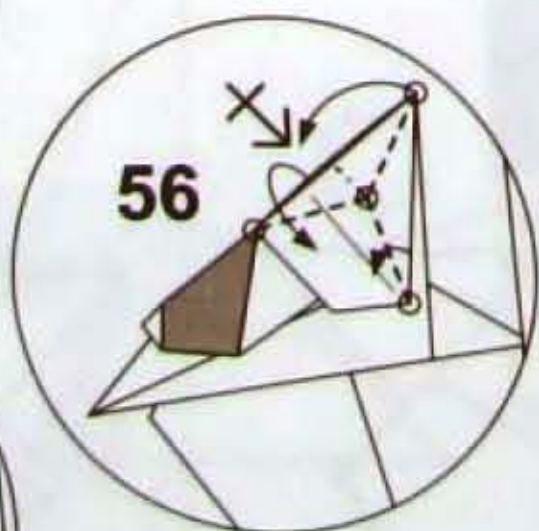

56



57

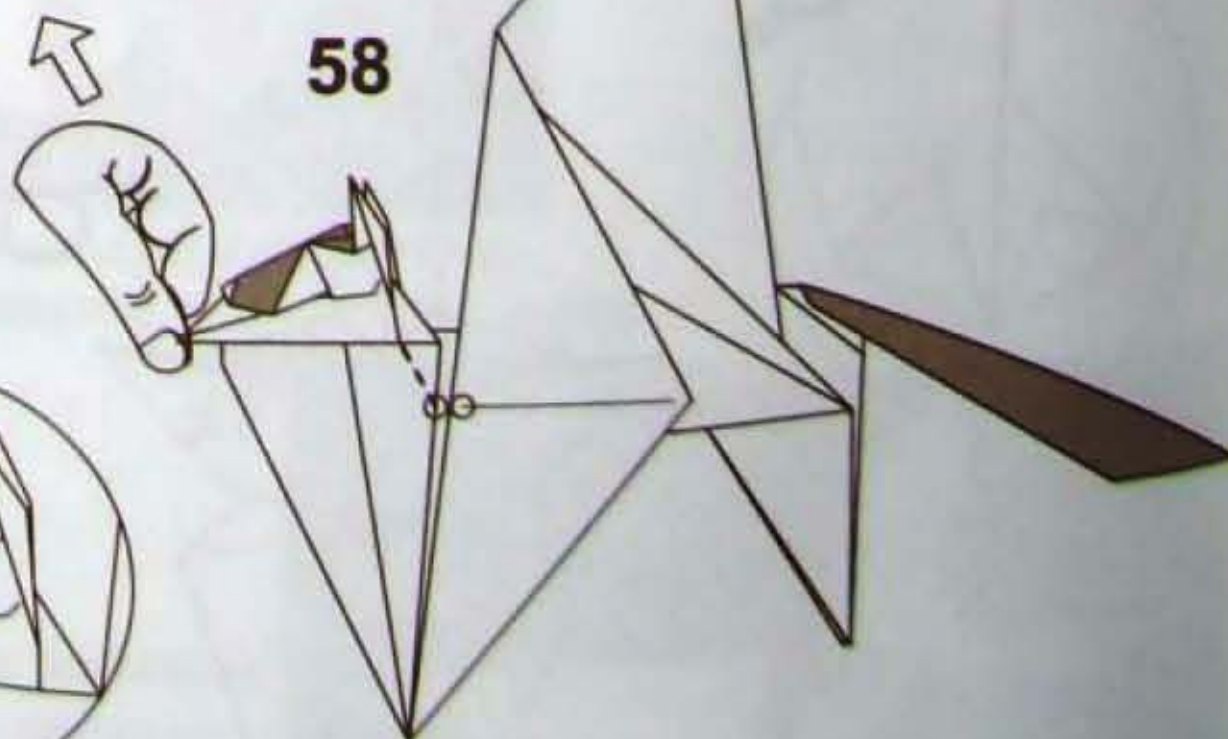

58

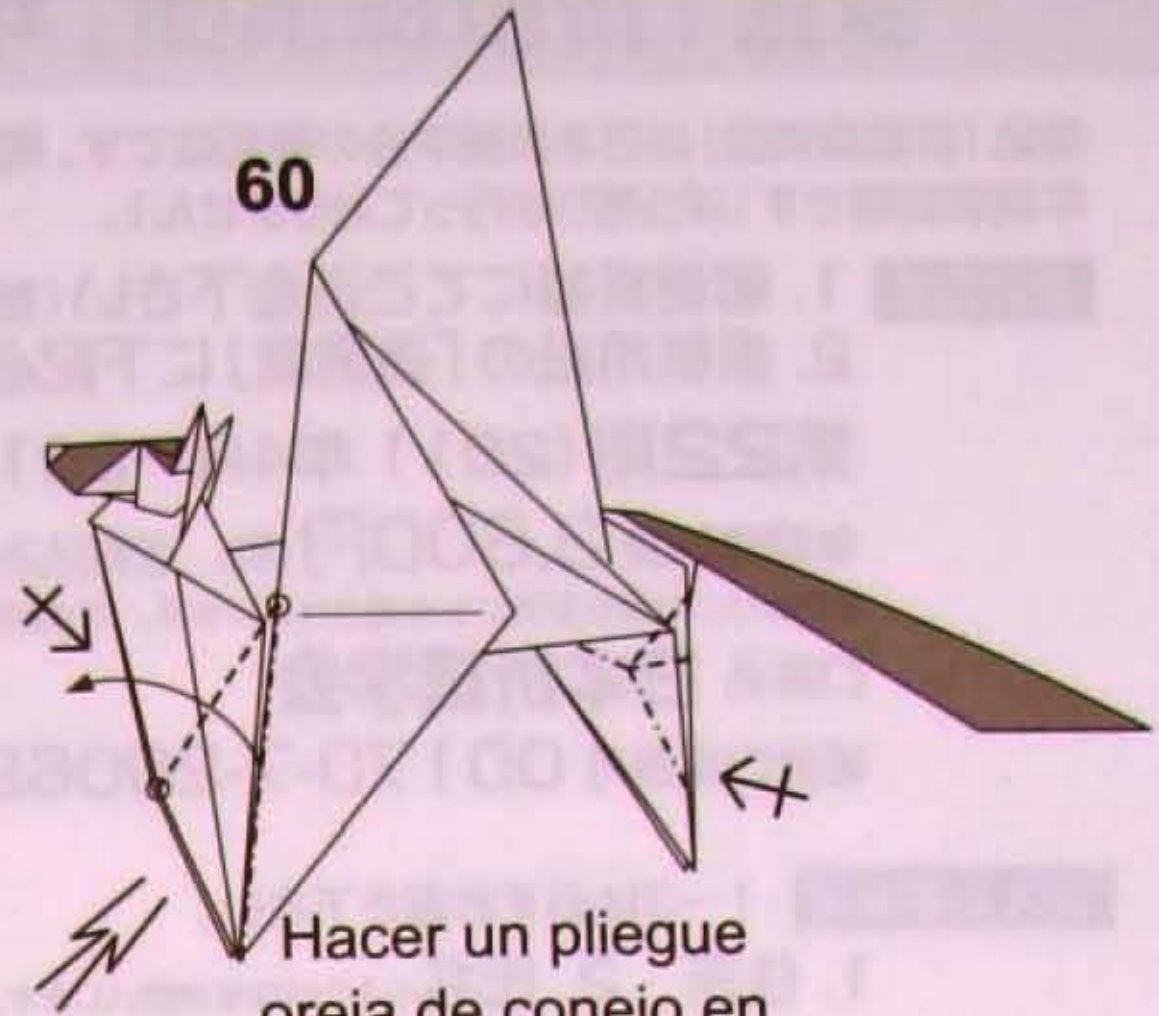
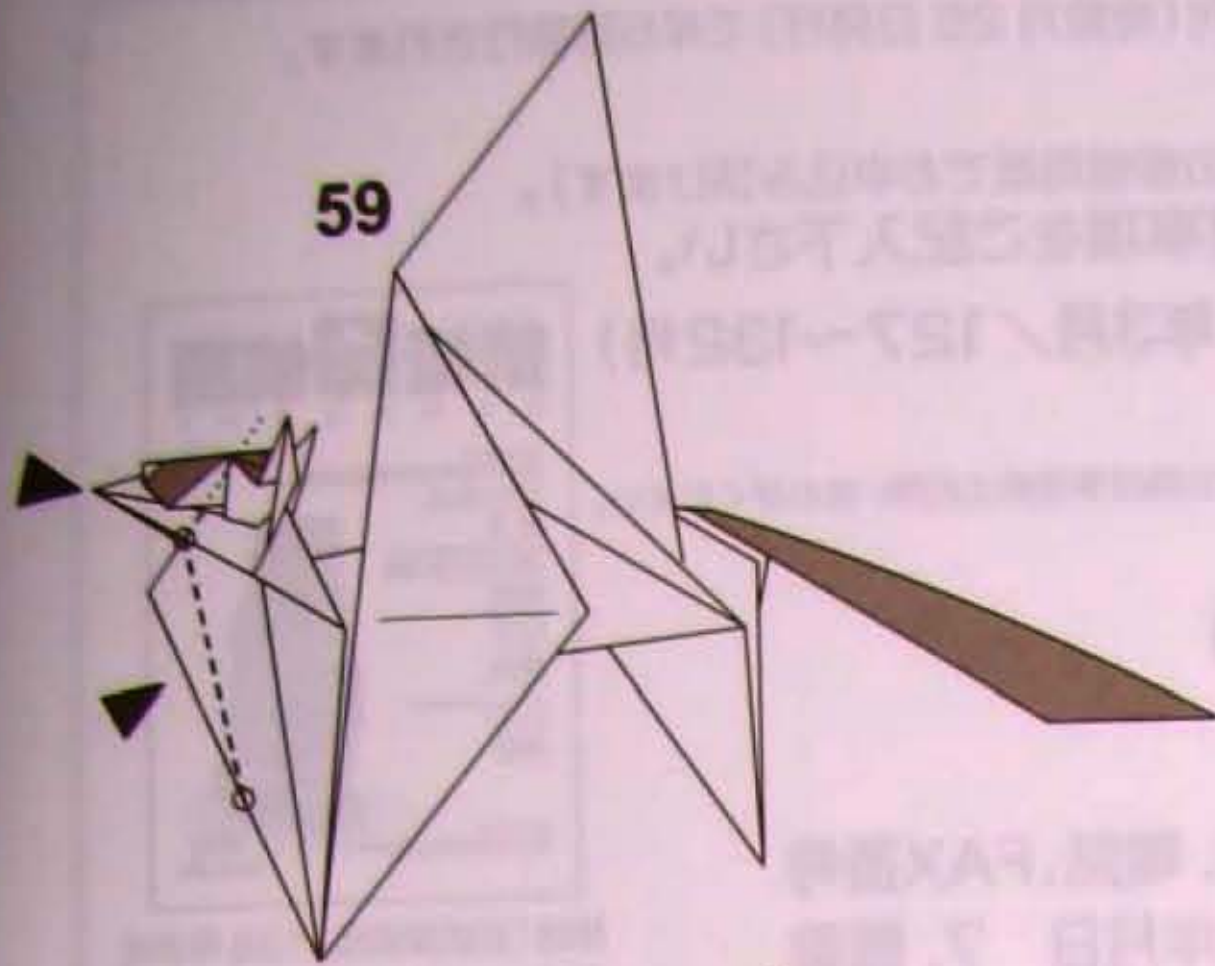

Hacer un pliegue oreja de conejo en las patas traseras

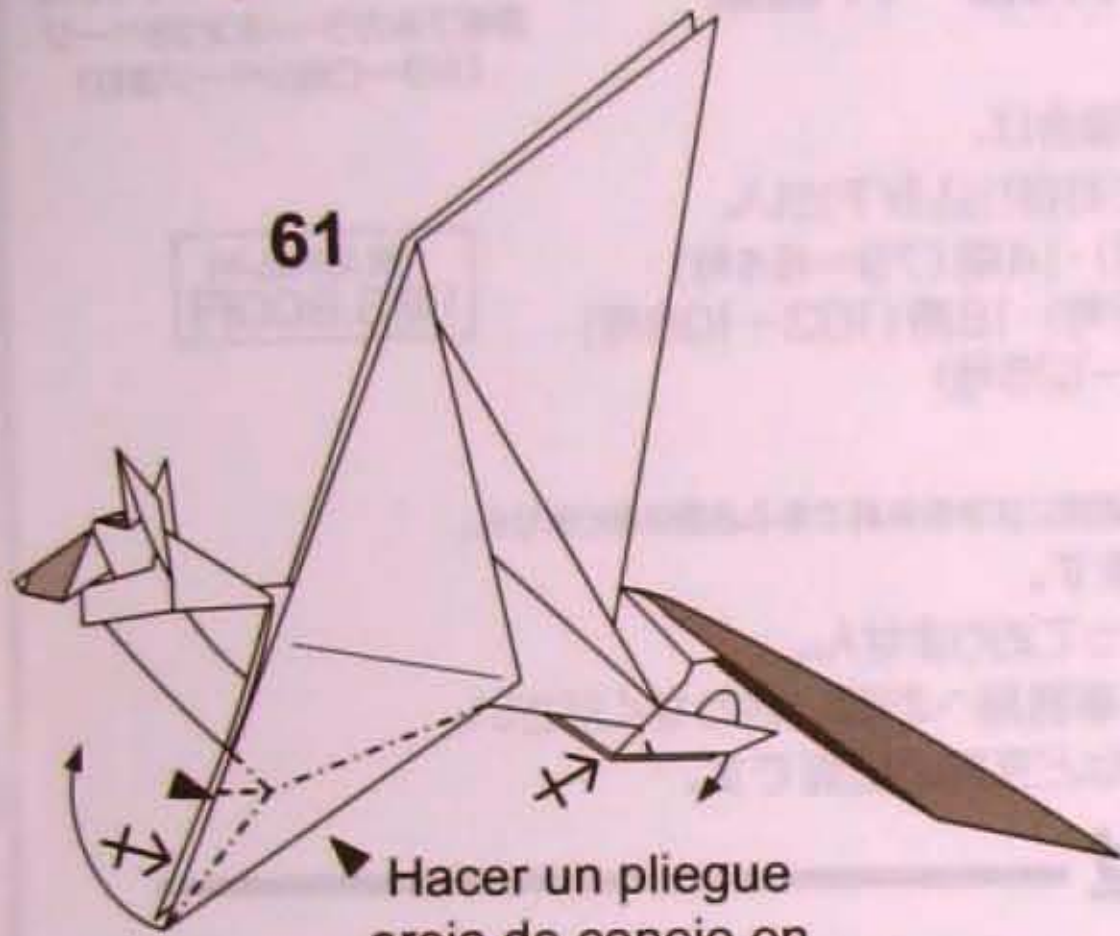

Hacer un pliegue oreja de conejo en las patas delanteras

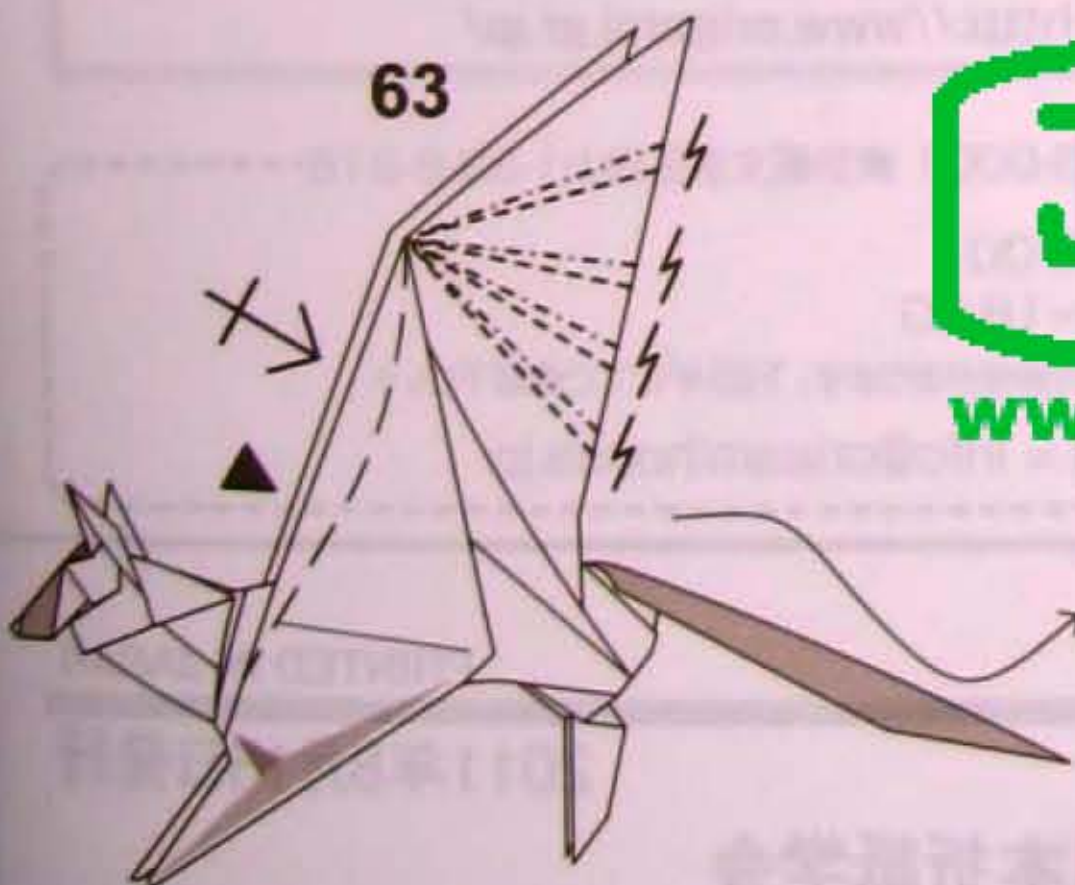
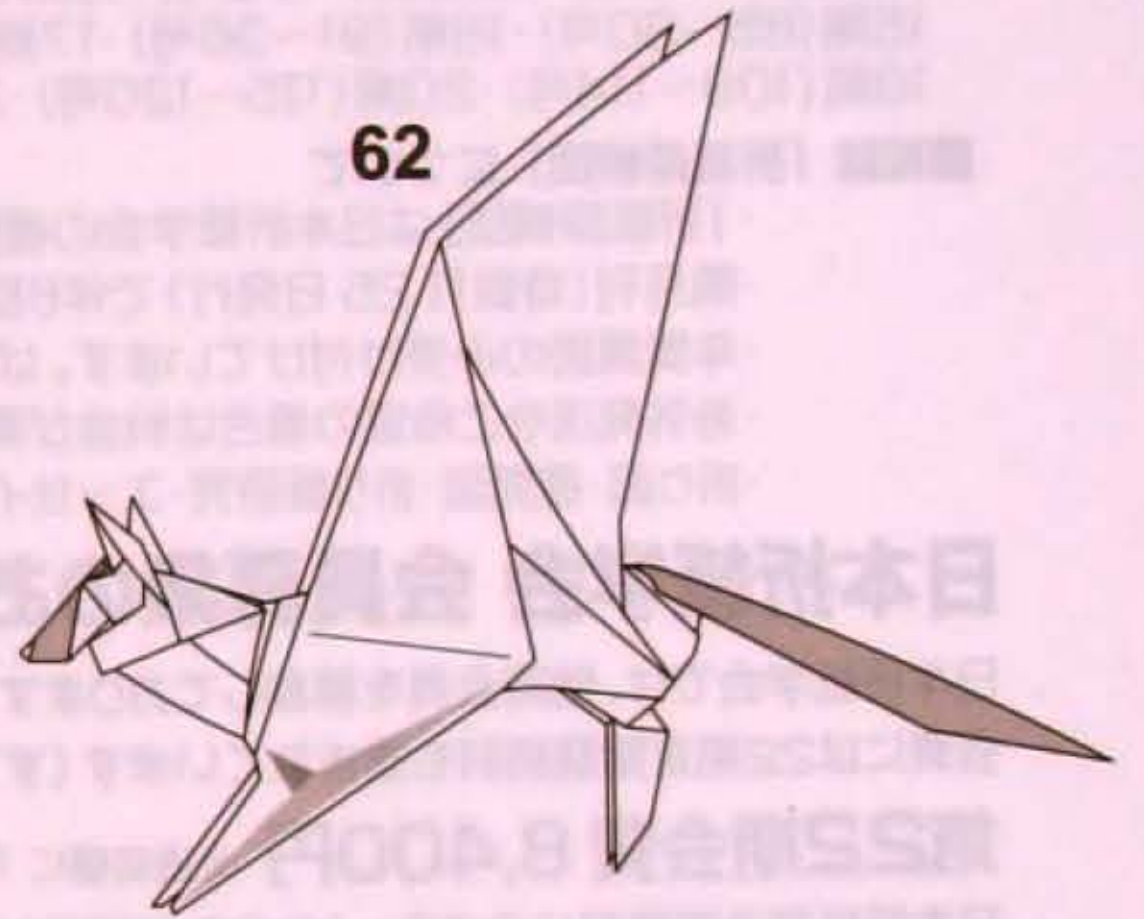

Dar forma de alas al lobo de forma escalonado, no solo las alas si no también la cola como se muestra la figura final

Japão Burajirujin

www.japaoburajirujin.blogspot.com



Fin del Modelo

雑誌『折紙探偵団』年間購読のご案内

雑誌『折紙探偵団』は日本折紙学会の機関誌です。隔月刊(奇数月25日発行)で年6回発行されます。年間購読制です(ばら売りは行っておりません)。

- 申込方法**
1. 郵便振替にてご送金下さい(普通の振替用紙でお申し込み頂けます)。
 2. 振替用紙の「通信欄」に下記必要事項をご記入下さい。

第22期(2011年4月~2012年3月/127~132号)

年間購読費 **3,800円**(税、送料込み)

期変わりに料金に変更になる場合があります。2012年4月以降は事務局にお問い合わせください。

口座名 **日本折紙学会**

振替口座番号 **00170-7-260699**



雑誌『折紙探偵団』128号表紙
表紙フルカラー/本文38ページ
(カラー口絵2ページ含む)

記入必要事項 1~3は必ずお書き下さい。

1. 住所
2. 氏名 ※ふりがなをお願いします。
3. 電話、FAX番号
4. E-Mailアドレス
5. 性別
6. 生年月日
7. 職業

■バックナンバー購入について

現在11期~21期を取り扱っております。購入ご希望の場合は、「通信欄」のところに希望する期を明記の上、相当金額をお振り込み下さい。

11期(61~66号)・12期(67~72号)・13期(73~78号)・14期(79~84号)・
15期(85~90号)・16期(91~96号)・17期(97~102号)・18期(103~108号)・
19期(109~114号)・20期(115~120号)・21期(121~126号)

■雑誌『折紙探偵団』について

- ・『折紙探偵団』は日本折紙学会の機関誌です。購読には学会会員である必要はありません。
- ・隔月刊(奇数月25日発行)で年6回発行されます。
- ・年間購読のみ受け付けています。ばら売りは行っておりません。
- ・海外発送をご希望の場合は料金が異なります。事務局へお問い合わせください。
- ・折り図・展開図・折り紙研究・エッセイ・最新情報など充実の誌面です。

(税、送料込み)
1期3,800円

日本折紙学会 会員募集のお知らせ

日本折紙学会では、随時会員を募集しております。申込方法は定期購読と同じです。

会費には22期定期購読料も含まれています(すでに22期を購読されている方は4,600円となります)。

第22期会費 8,400円 ※通信欄に「第22期会費」と明記してください

日本折紙学会事務局(10:00~18:00 日祝休) 〒113-0001 東京都文京区白山 1-33-8-216
Phone/Fax 03-5684-6080 日本折紙学会ホームページ <http://www.origami.gr.jp/>

ギャラリーおりがみはうすのご案内 〒113-0001 東京都文京区白山1-33-8-216

- 1989年にオープンした、日本最初の折り紙作品専門ギャラリー。公開時間は右記の通りです。
- 営業日/月曜~金曜 12:00~15:00
/土曜・日曜・祭日 10:00~18:00
定休日/なし(公開時間に変更される可能性があります。下記HPにてご確認ください)

ホームページ = <http://www.origamihouse.jp/> e-mail = info@origamihouse.jp

第17回 折紙探偵団コンベンション折り図集

PRINTED IN JAPAN

2011年8月13日発行

著者/日本折紙学会

発行人/西川誠司

編集人/山口 真

編集スタッフ/神谷哲史・勝田恭平

デザイン/おりがみはうす

発売元/おりがみはうす

発行所/日本折紙学会

113-0001

東京都文京区白山 1-33-8-216 (ギャラリーおりがみはうす内)

Phone & Fax 03-5684-6080 (10:00~18:00/日・祭日休)

E-mail = webman@origami.gr.jp

Web Site = <http://www.origami.gr.jp/>

■Origami Tanteidan Convention Book vol.17 / Published on 13, August 2011 by Japan Origami Academic Society, 1-33-8-216 Hakusan Bunkyo-ku
113-0001 Tokyo JAPAN / Publisher : Nishikawa Seiji / Editor in Chief : Yamaguchi Makoto / Editorial Design : OrigamiHouse

ORIGAMI TANTEIDAN
折紙探偵団
MAGAZINE
17th CONVENTION 2011

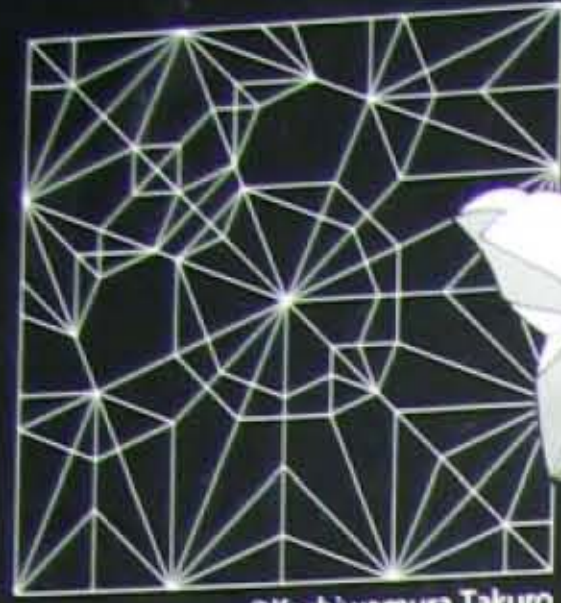

©Kashiwamura Takuro

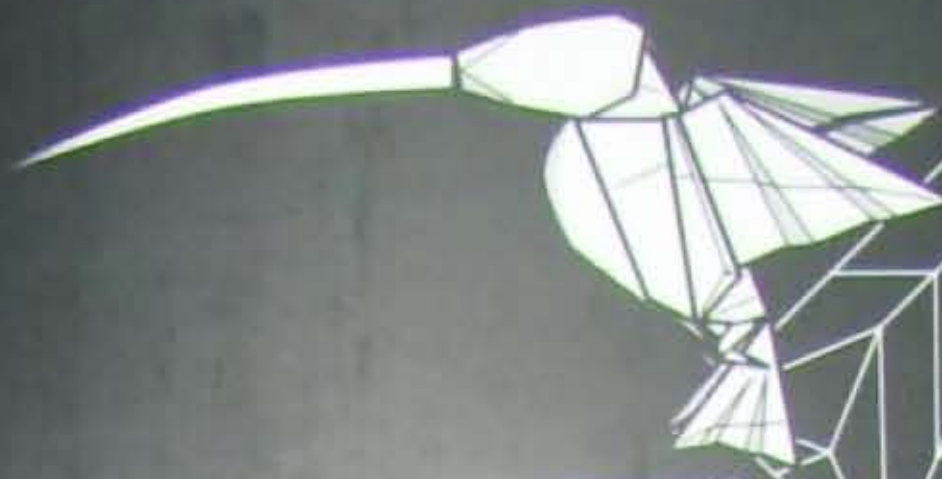
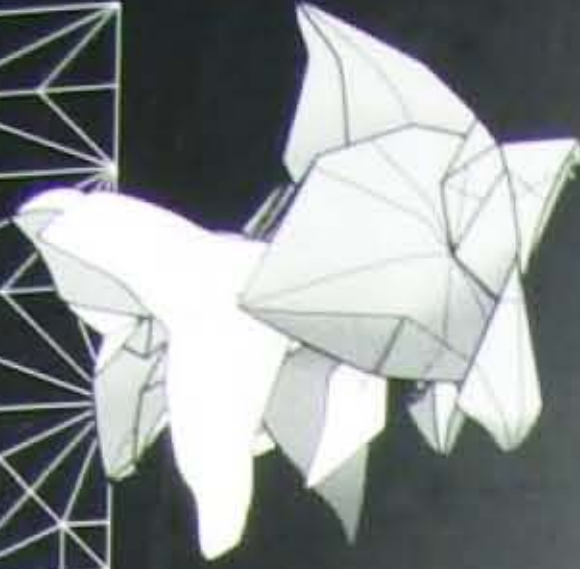

©Ryan Welsh

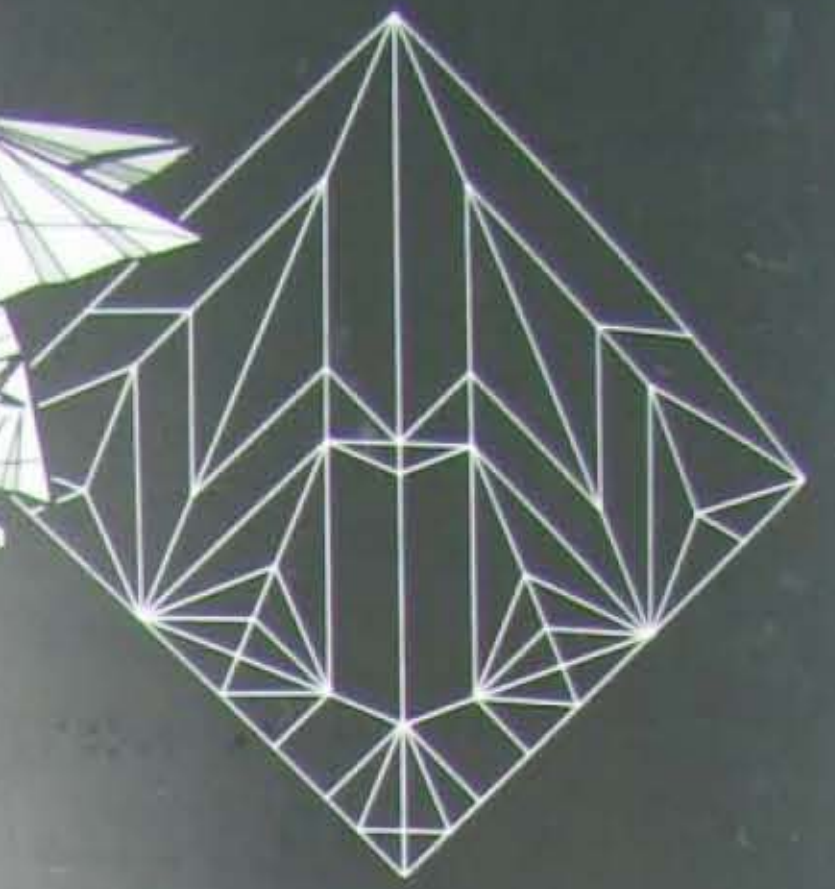

Japão Burajirujin

www.japaoburajirujin.blogspot.com

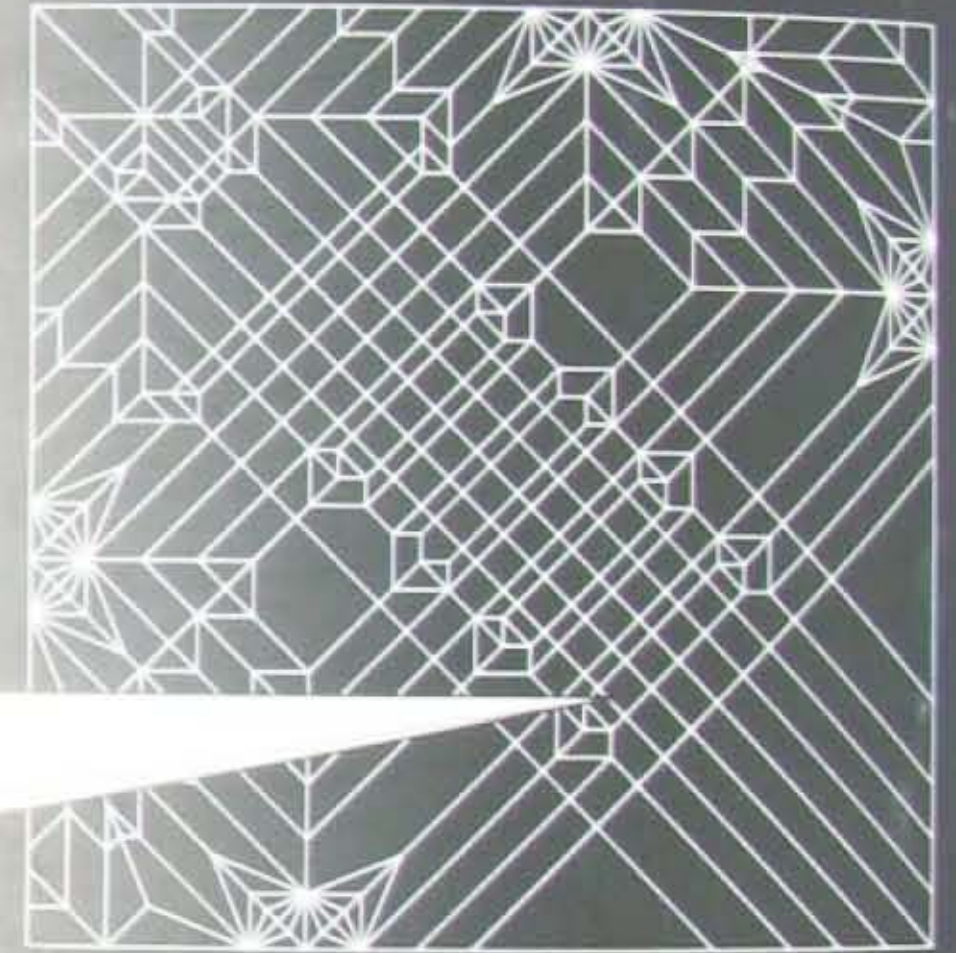
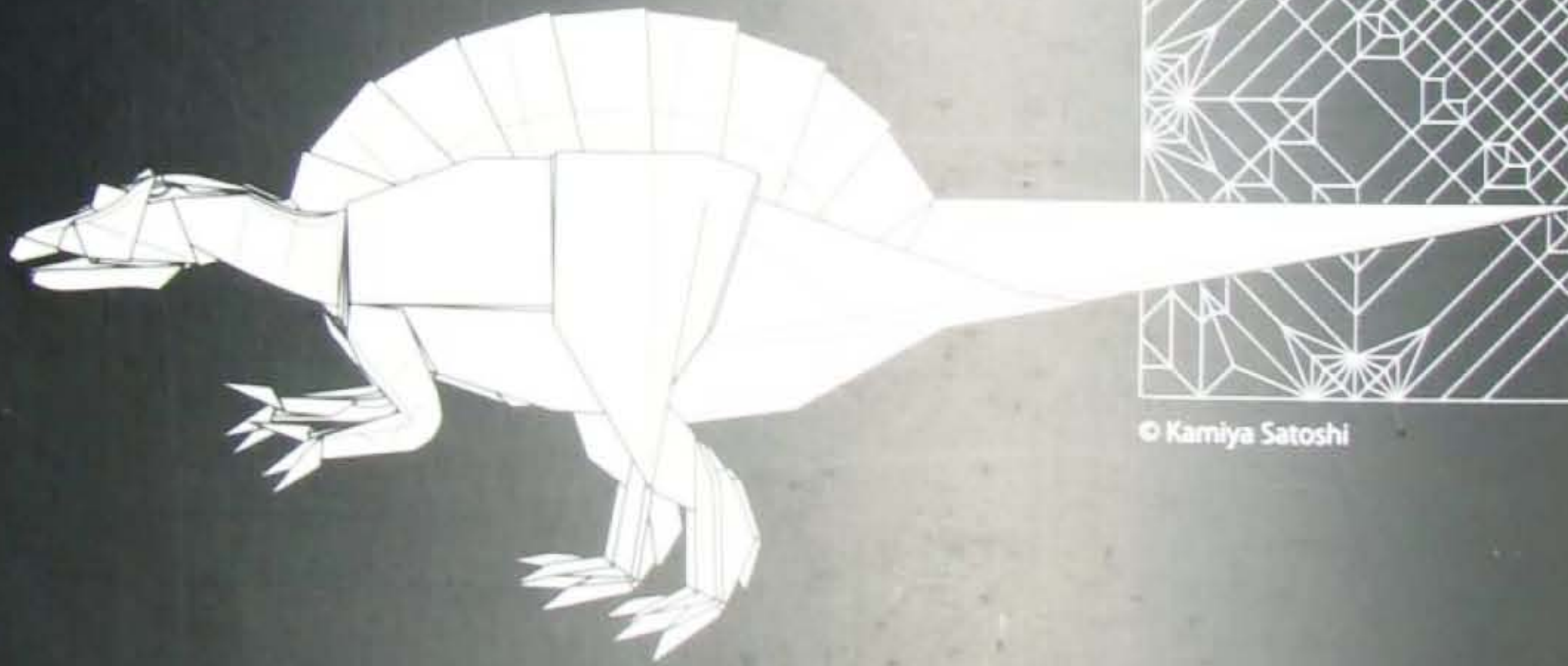

© Kamiya Satoshi

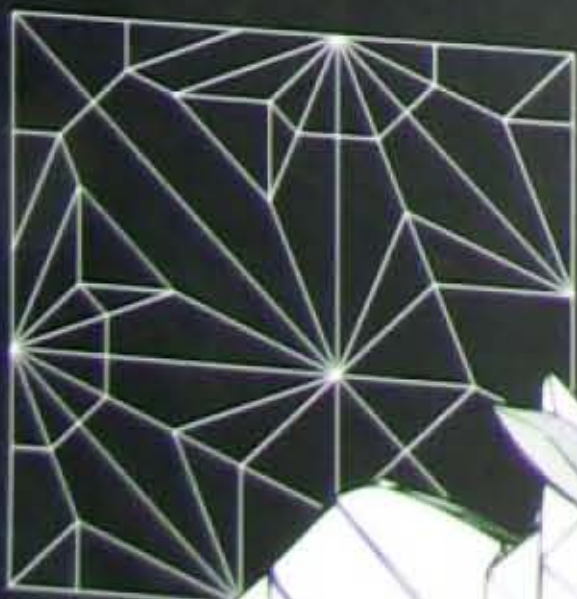

©Hagiwara Gen

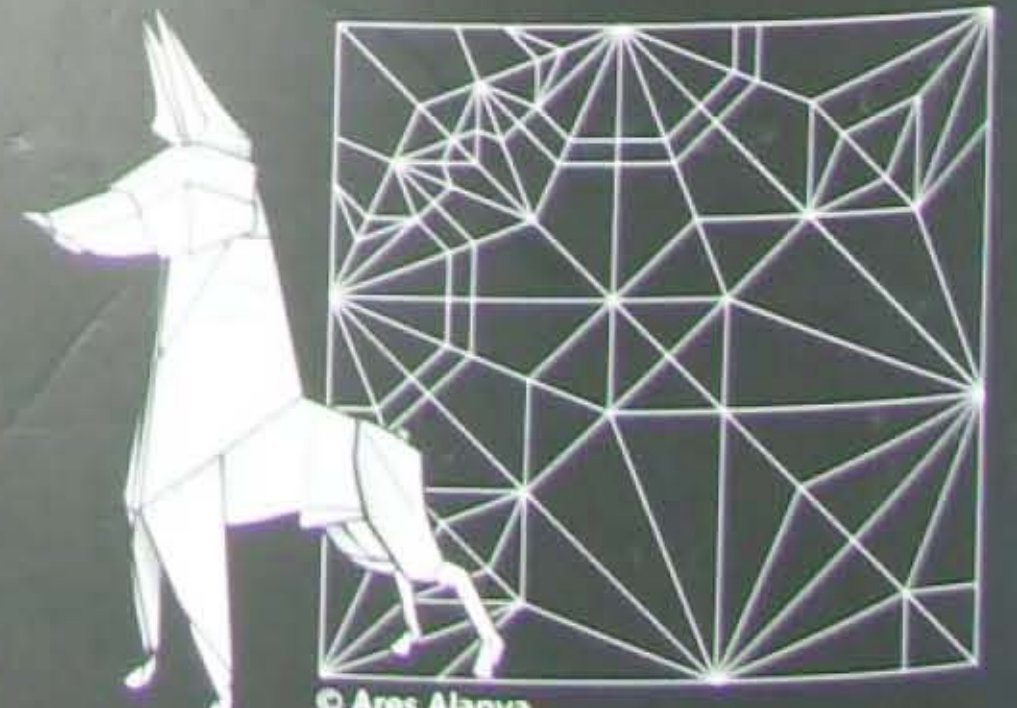

© Ares Alanya



定価 2,000円