

ORIGAMI TANTEIDAN 16th CONVENTION

第16回

折紙探偵団  
コンベンション

Japão Burajirujin

[www.japaoburajirujin.blogspot.com](http://www.japaoburajirujin.blogspot.com)

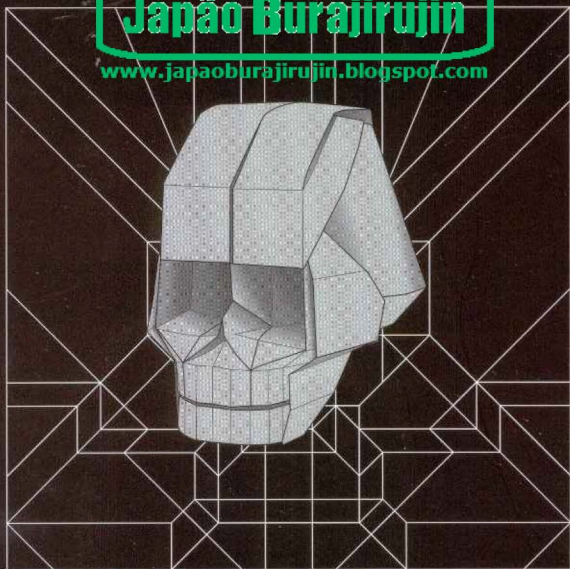

© Hojo Takashi

折り図集

Vol.16

発行・日本折紙学会

16th Origami Tanteidan Convention

第16回  
折紙探偵団  
コンベンション

**Japão Burajirujin**

[www.japaoburajirujin.blogspot.com](http://www.japaoburajirujin.blogspot.com)

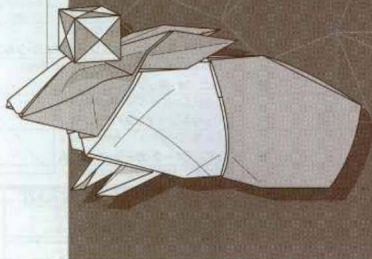

©Komatsu Hideo

折り図集

Vol. 16

発行・日本折紙学会



## CONTENTS

折り図記号 Symbols for Folding	3	デュアロ/川村みゆき DUALO / Kawamura Miyuki	12
基本形・沈め折り Preliminary Bases and Sink	4	卍キューブ/尾川 知 卍 Cube / Ogawa Tomo	13
<b>国内編: Models by Japanese Folders</b>		Ghost Cube ~ 曇める立方体 Skeleton / 齋 誠志 Ghost Cube / Kasumi Seishi	15
はこぞう/木村良寿 Cube-Eleph / Kimura Yoshihisa	6	<b>海外編: Models by Foreign Folders</b>	
ふた/小松英夫 Fig / Komatsu Hideo	7	虎の子供/ビクトリア・セーロワ The Tiger cub, version2 / Victoria Serova	14
トナカイ/中井 努 Reindeer / Nakai Tsutomu	10	マレーバク/クエンティン・トロリッ Malay Tapir / Quentin Trollip	15
うさぎ/中川幸治 Rabbit / Nakagawa Kouji	14	マッド・カウ/フェルナンド・ヒルガド Mad Cow / Fernando Gilgado	16
リス/萩原 元 Squirrel / Hagiwara Gen	19	馬/ニコラ・ガハルド・エンリケス Caballo / Nicolas Gajardo Henriquez	18
仔猫/勝田恭平 Kitten / Katsuta Kyohei	24	マンモス/パヴェル・ニクルシン Mammoth / Pavel Nikulshin	19
ツシマヤマネコ/津田良夫 Tushima Cat / Tsuda Yoshio	30	ニワトリ/アンドリュウ・ニーホール Chicken / Andrew Neehall	20
シカ/西川誠司 Deer / Nishikawa Seiji	36	白鳥/ホアン・ティン・クエット Swan / Hoang Tien Quyét	21
うさぎ 2 / 小松英夫 Rabbit 2 / Komatsu Hideo	42	コモリグモ/ブライアン・チャン Wolf Spider / Brian Chan	22
クマ/福田 亨 Bear / Fukuda Toru	49	アレクサンダースワローテイル/マイケル・G・ラフォーース Alexander Aztec Swallowtail / Michael G. LaFosse	23
ふくろう/津田良夫 Owl ver.2 / Tsuda Yoshio	60	カタツムリ/グエン・フン・クオン Snail / Nguyen Hung Cuong	24
小鳥/宮島 登 Little Bird / Miyajima Noboru	63	ヘラクレスオオカブトムシ/マヌエル・シルゴ Hercules Giant Beetle / Manuel Sirgo	25
カブトムシ/川村みゆき Beetle / Kawamura Miyuki	68	カニ・オ・ギョクフ Small Crab / Oh, kyu-seok	26
トカゲ/山本大雅 Lizard / Yamamoto Taiga	71	リュウキン/アレク・アランヤ Fantail Goldfish / Ares Alanya	27
ペテラノドン/川畑文昭 Pteranodon / Kawahata Fumiaki	76	バラ マーク・カーシェンバウム Rose / Marc Kirschenbaum	28
アカウミガメ/神谷哲史 Loggerhead sea turtle / Kamiya Satoshi	84	ウイングハート/ホアン・ティン・クエット Wing-heart / Hoang Tien Quyét	29
クローントルーパー(ヘルメット)/森末 圭 Clone Trooper (Helmet) / Morisue Kei	99	フェアリー/ジェイソン・ク Fairy / Jason Ku	30
ガイコツくん4号/北條高史 Skull (with 3-D eye sockets) / Hojyo Takashi	102	フォッカー DR1 "レッドバロン"/アレクサンドロ・ペバー TRIPLANO FOKKER DR1 "Red Baron" / Alessandro Beber	31
人の形/藤倉敦夫 Human Figure / Fujikura Atsuo	108	5 x 5 チェスボード1/ジョン・モントロール 5 x 5 Chess Board 1 / John Montroll	32
おひな様/浜田 勇 Hina Doll / Hamada Isamu	110	5 x 5 チェスボード2/ジョン・モントロール 5 x 5 Chess Board 2 / John Montroll	33
あやめ/前川 淳 Iris / Maekawa Jun	112	アダガ/アイサ・クライン Adaga / Isa Klein	34
ヘリコプター/武井純二 Helicopter / Takei Junji	116	クロエの星/ビル・レイエス Chloe's Star / Bill Reyes	35
サザエキューブ/川崎敏和 A turban shell cube / Kawasaki Toshikazu	119		

## 折り図記号 Symbols for Folding

### 折り線の種類 Types of crease lines

#### 谷折り線 Valley fold



谷折り  
Valley fold



#### 山折り線 Mountain fold



#### 山折り Mountain fold



### 折り方の技法 Basic Folding Skills

#### 中わり折り Inside-reverse fold

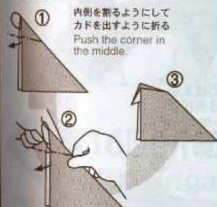

内側を翻るようにしてカドを出すように折る  
Push the corner in the middle.

#### かぶせ折り Outside-reverse fold

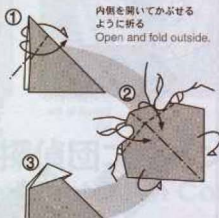

内側を開いてかぶせるように折る  
Open and fold outside.

#### 内側をひろげてつぶすように折る Squash fold

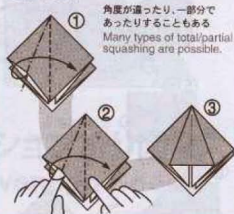

角度が違ったり、一部分であったりすることもある  
Many types of total/partial squashing are possible.

### いろいろな記号 Symbols

#### 折り筋をつける Making a crease line



一度折ってから戻して折り筋をつける  
Fold and mark a crease line, then unfold.

#### 裏返す Turn paper over

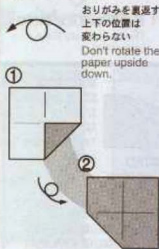

おりがみを裏返す上下の位置は変わらない  
Don't rotate the paper upside down.

#### 段折り Pleat fold

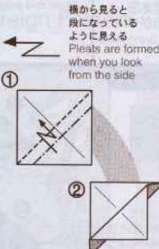

横から見ると段になっているように見える  
Pleats are formed when you look from the side

#### 下の部分を出すように折る Release bottom flap when making a fold

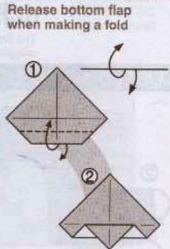

#### 次の図が大きくなる A magnified view



#### 仮想線・透視線 A hidden line



#### 押し・つぶす Push paper in



#### 引き出す Pull out



#### ひろげる Open up



#### ○と○を合わせて折る Match circled points



#### 巻くように折る Roll the flap by repeated folds

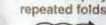

#### 注意するところ Marked points



#### 次の図の見え位置が変わる Paper position changes (rotation)

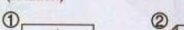

視点が大きく変わる場合この記号の位置から見る  
The viewpoint shifts to this position.



#### 等分記号 Division

##### 長さの等分 Dividing the length



数字で表す場合もある  
The ratio is often represented with numbers.

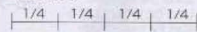

##### 角度の等分 Dividing the angle



1つの図で2種類の等分を表す場合



# 基本形 / 沈め折り Preliminary Bases and Sink

## 基本形 Preliminary bases

### 風船基本形 Water Bomb Base

① 半分を折る  
Fold in half.

② 半分を折る  
Fold in half again.

③

④

⑤ 反対側に折る  
Swivel to the left.

⑥ 内側をひろげて つぶすように折る  
Open and squash.

⑦ 風船基本形 できあがり  
The Water Bomb Base completed.

## 正方形基本形と鶴の基本形 Preliminary Base / Bird Base

① 三角に折る  
Fold corner to corner.

② 三角を折る  
Fold in half.

③ 内側をひろげて つぶすように折る  
Open and squash.

④

⑤ 反対側に折る  
Swivel to the left.

⑥ 内側をひろげて つぶすように折る  
Open and squash.

⑦ 正方形基本形 できあがり  
The Preliminary Base completed.

⑧ 線を中心に合わせて 折り筋をつける  
Fold the lower edges to the center diagonal.

⑨ 内側をひろげて つぶすように折る  
Open, swivel up and squash.

⑩ 反対側も ⑧～⑩と同じ  
Repeat ⑧～⑩ on the back.

⑪ 鶴の基本形 できあがり  
The Bird Base completed.

## 沈め折り Open sink / Closed sink

① カドを斜めに折る  
Fold down.

② カドを内側に折る  
Inside reverse fold.

③ 沈め折りをする部分に しっかりと折り筋をつける  
Mark the crease line to use for sink.

④ Open sink (オープン・シンク)  
つけた折り筋を使って 沈めるように折る  
Push the arrowed corner inside ...

⑤ 途中の角 全体をひろげてから 押し込むように折る  
After opening the corner lightly, push in without overlapping layers.

⑥ できあがり  
Open sink completed.

⑥ 紙のひだが開いた (closed) かたちになっている  
The layers are locked.

⑤ 途中の角 紙の重なりを開かないまま押し込むように折る  
Push in with layers overlapped to each other.

⑥ 紙のひだが開いた (open) かたちになっている  
The layers can be reopened.

⑥ できあがり  
Closed sink completed.

ひだの形によってはclosed sink しかできない場合もあります  
Certain complexes of layers allows only for closed sink.

① カドを斜めに折る  
Fold down.

② 沈め折りをする部分に しっかりと折り筋をつける  
Mark the crease line to use for sink.

③ つけた折り筋を 使って沈めるように折る  
Push in the corner.

④ できあがり  
The closed sink completed.

# Japão Burajirujin

[www.japaoburajirujin.blogspot.com](http://www.japaoburajirujin.blogspot.com)

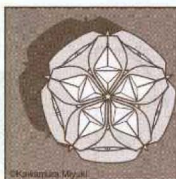
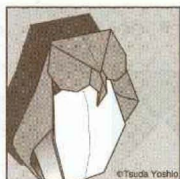

## 第16回折紙探偵団コンベンション折り図集 16th Origami Tanteidan Convention Book

国内編 / Models by Japanese Folders P.6

海外編 / Models by Foreign Folders P.130

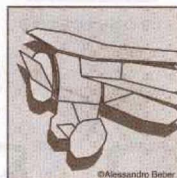



# はこぞう Cube-Eleph

2008.07.15 創作 Designed

2010.06.22 作図 Drawn

2008年に大量に作った「はこ」シリーズの一つです。  
当初は頭を別の紙で折った二枚組でしたが、一枚でも出来そうなので作ってみました。こちらの方がまとまりが良くなりました。

## 木村良寿

Kimura Yoshihisa

08年東京コンベンション  
09年名古屋コンベンションにて講習済

(1) 折りすじをつける

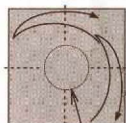

ただし中央部には  
すじをつけないように

(2)

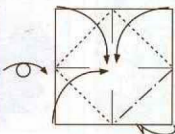

ざぶとん折り  
一ヶ所だけ裏側に

(3) この一枚だけもどす

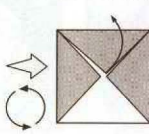

(4)

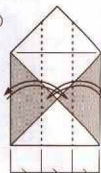

1/3の折りすじをつける

(5)

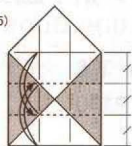

1/3の折りすじをつける

(6)

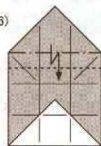

段折り

(7) (4)(5)でつけた  
折りすじで直角に折る

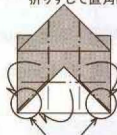

ここはつまむように折る

(8)



こちらから見る

(9)



片方のかどを  
もう一方に入れる

(10)



こちらから見る



(11)

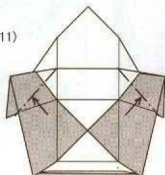

ここに折りすじをつけることにより

(12)

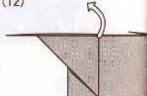

頭を引き上げる

(13)

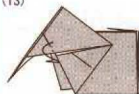

前足にそってに折りすじをつけ

(14)

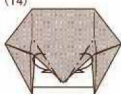

鼻をほそく折る

(15) 耳を直角に折る



鼻を下に下げる

(16) 尾を後ろに折る

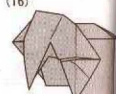

# ぶた

創作・折り図：小松英夫

Pig by Komatsu Hideo

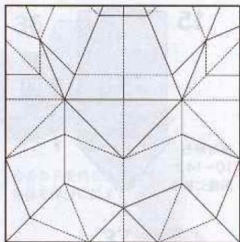
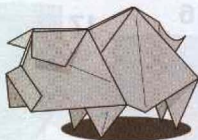

折りのおもしろさを優先した結果、あえて誤差の出か  
ない折り筋のつけ方をしています。ですので特に  
12ではびったりとフチを合わせて折ってください。  
28できれいな扇形が現れたら“成功”です。

## Japão Burajirujin

[www.japaoburajirujin.blogspot.com](http://www.japaoburajirujin.blogspot.com)

1

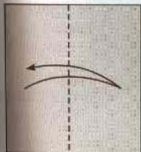

折り筋を  
つける

2

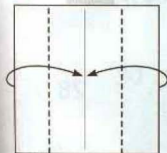

フチを折り筋に  
合わせて折る

3



フチを合わせて  
折り筋をつける

4



つけた折り筋で  
カドを中割り折り

5



10



○のところから  
フチを合わせて折る



6



手前のカドを  
上に折り返す

12

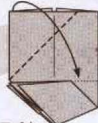

フチを  
合わせるように  
カドを折る

13



フチを  
合わせて折る

9



カドを  
下に戻す

8



フチを折り筋に  
合わせて  
折り筋をつける

7



15

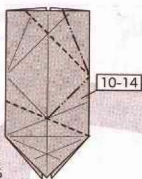

反対側も  
10~14と  
同様に折る

16



ついている折り筋で  
○がくぼむように折る

17



(途中の図)  
平らに折りたたむ

18

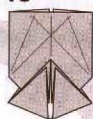

19

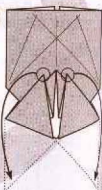

2つのカドを  
下げるようにひら

14



グリラのできあがり (嘘)  
しっかりと  
折り筋をつけてから  
10の形まで戻す

20

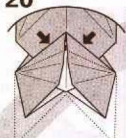

(途中の図1)  
上のカドを  
ついている折り筋で  
つまむように折る

22



カドを  
反対側に  
折り返す

21

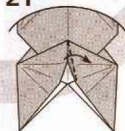

(途中の図2)  
あまったカドを  
平らにつぶす

23



カドを  
内側に  
隠すように折る

28

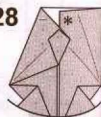

\*の紙を手前に出す

## Japão Burajirujin

[www.japaoburajirujin.blogspot.com](http://www.japaoburajirujin.blogspot.com)

24

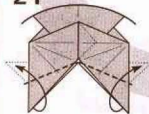

折り返したフチが  
水平になるように  
カドを折る

25

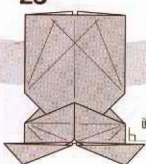

直角

26

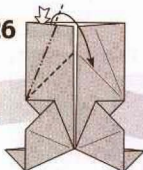

ついている折り筋で  
内側をひろげて  
つぶすように折る

27



○を結ぶ線で折る

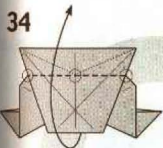

○を通る線で  
上に折り返す

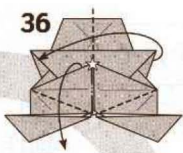
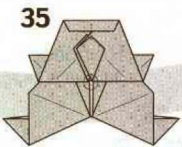

☆のカドを持ち上げながら  
全体を半分にする

**Japão Burajirujin**  
www.japaoburajirujin.blogspot.com

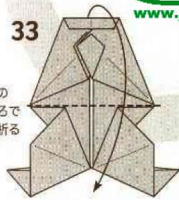

カドの  
ところで  
下に折る

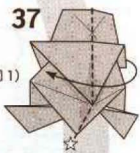
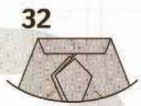

(途中の図1)

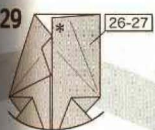

右側も 26~27 と  
同様に折る

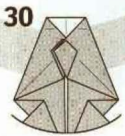

左右についている  
折り筋のところを折る  
(裏白が見えなくなる)



(途中の図2)  
重なっている部分を折らずに  
外へ出すようにする

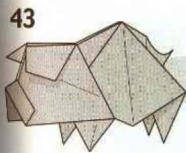
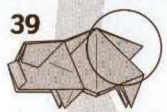

できあがり

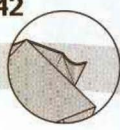

カドを円錐状に  
カールさせる



○を目安に折る



## トナカイ

Reindeer  
Model & Diagrams by Tsutomu Nakai

作/図 中井 努  
創作 2010年 5月  
作図 2010年 5月

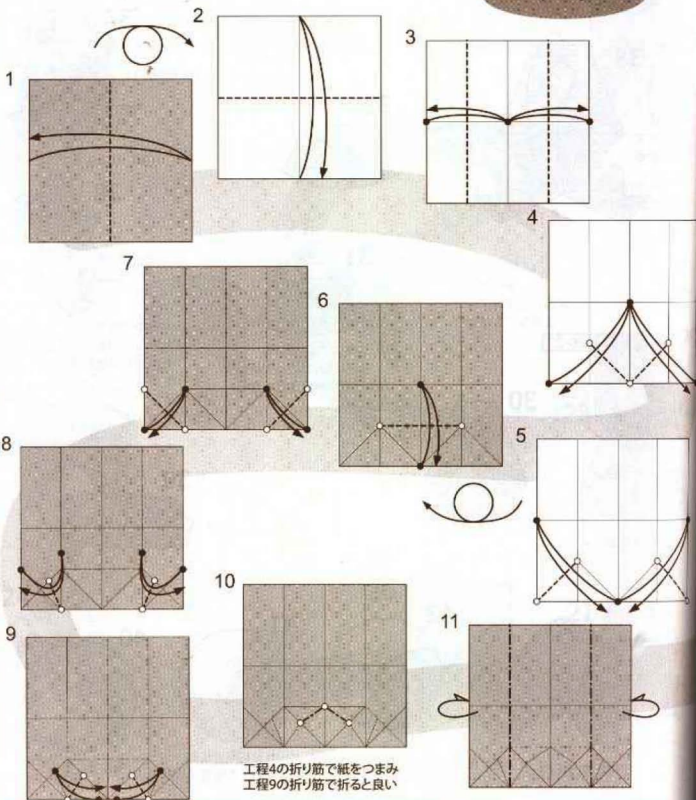

工程4の折り筋で紙をつまみ  
工程9の折り筋で折ると良い

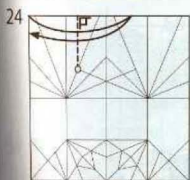

○印を通り、紙の縁に垂直な折り筋をつける

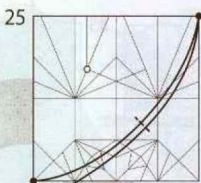

●印を合わせるように折り、図の辺りにだけ折り筋をつける

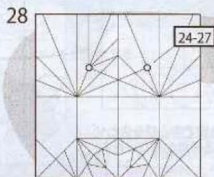

反対側も工程24-27と同様に折る



●印の間の折り筋を○印まで延長する

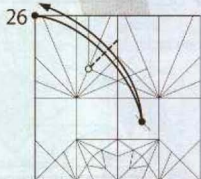

●印を合わせ、○印と中心線との間に折り筋をつける

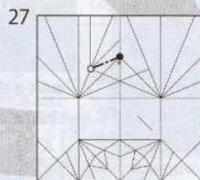

○印と●印との間に山折りの折り筋をつける

**Japão Burajirujin**  
www.japaoburajirujin.blogspot.com



全て広げる



2層までめて折る

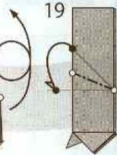

16

反対側も工程16と同様に折る

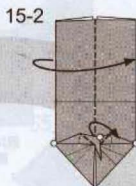

次に工程10の折り筋を利用して中割り折りのようにして畳む

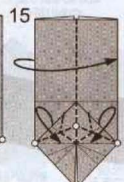
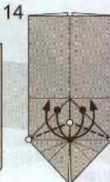

図の折り筋で畳む (途中図15-1,15-2参照)



まず工程14の折り筋を利用し、

トナカイ / 中井 努 (埼玉県)

29

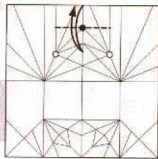

●印を通る線で中心線を合わせ  
○印を通る垂線の間だけ折る

30

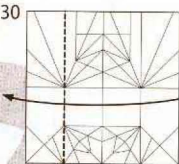

35

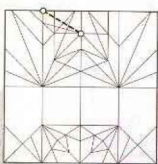

○印を通る線で折り筋をつける

32



工程30の状態に戻す

31

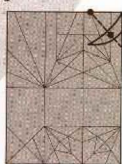

●印を通る線で折る

34

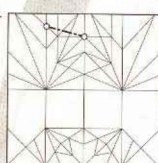

○印を通る線で折り筋をつける

36

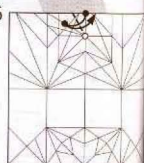

○印を通る線で角を等分

33

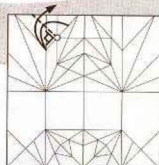

37

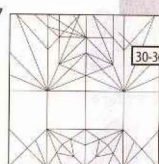

30-36

反対側も工程30-36と同様に折る

41



向こう側も同様

41



既にある折り筋で  
開いてつぶす

40



既にある折り筋で  
中割り折り

39



38

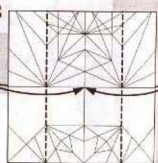

43

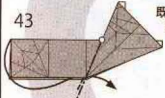

紙の縁の折り筋で中割り折り

44



既についている折り筋で  
沈め折り (OPEN SINK)

45



右手で☆印の所をつまみ、  
左手で左側の縁の○印部分を  
紙面鉛直方向に開きながら  
既についている線でたたむ

46

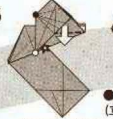

新しい折り筋を  
付けないように  
内側の紙を引き出す  
(立体的な工程が続く)

47



●印を結ぶ谷線を折る  
(立体的な工程が続く)

48

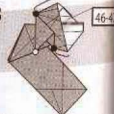

●印から紙の縁までの部分が  
平面におさまらないまま  
裏側も工程46-47と同様に折る  
(立体的な工程が続く)

46-47



65 半分の幅で段折り

66 中割り折り

67 ○印と●印を結ぶ線をつまむようにして奥の紙の線に合う所まで引き寄せる

68 ○印をとる線の所でひらく

69 既についている折り筋で工程13-15と同様に折る

70 視点変更

71 既についている○印をとる線で内側に折る

72 既についている線で折る

73 内側に折ってすぐ後ろに入れる

74 工程74の☆印を通る線と●印を通る線で引き寄せる

75 ●印をつまみ左右に広げる

76 ●印を結ぶ線で折る

77 工程76で広げた紙を戻す

78 ツノを立体化する

79 反対側も工程75-78と同様(透視修了)

80

81 できあがり

64 開く(視点変更)

63 拡大修了

62 反対側も工程59-61と同様

61 線に合わせて内側へ折る

60 線に合わせて内側へ折る

59 工程53の角度だけ●印を通る線で引き寄せる

58 内側へ入れる

57 反対側も工程56と同様

56 OPEN SINK

55 元に戻す

54 ●印を通る線で、半分の角度で山折り

53 ●印を通る線で、半分の角度の折り筋をつける

52 部分拡大

51 山谷を入れかえすぐ内側へ入れる

50 開いてつぶす

49 ●印から紙の線までの部分は新しい折り筋をつけて平面になるようにたたむ

立体的なツノのトナカイを目標に制作した作品です。ツノの枝分かれが少ない、面白いデザインになりました。作品名は「ナカイトナカイ」というのが何度も頭を過りましたが、オーソドックスに「トナカイ」としました。



## うさぎ

Rabbit

### 中川 幸治

Kouji Nakagawa

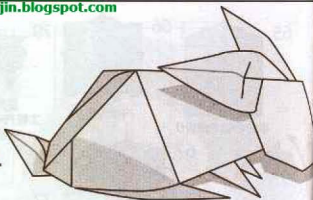

創作: 2009年 4月

作図: 2010年 1月

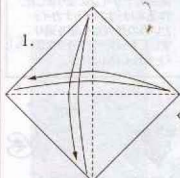

1. 対角線に折り筋を付ける。

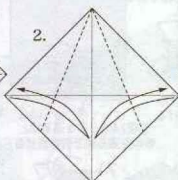

2. 辺を中心線に合わせて折り筋を付ける。

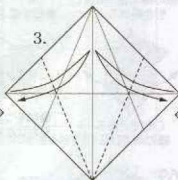

3. 辺を中心線に合わせて折り筋を付ける。

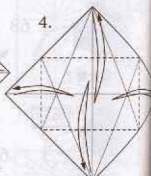

4. 折り筋を付ける。

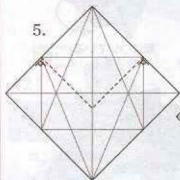

5. 辺に対して垂直に折り筋を付ける。

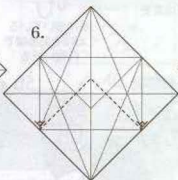

6. 辺に対して垂直に折り筋を付ける。

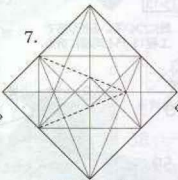

7. 折り筋を付ける。

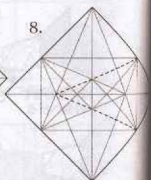

8. 折り筋を付ける。

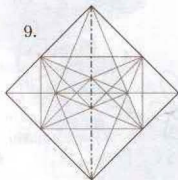

9. 中心で半分に折る。

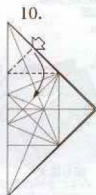

10. 開いて潰す。

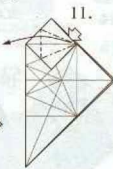

11. 開いて潰す。

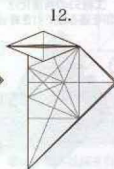

12. 10.まで戻す。



13. 下側も10~12と同じように折る。

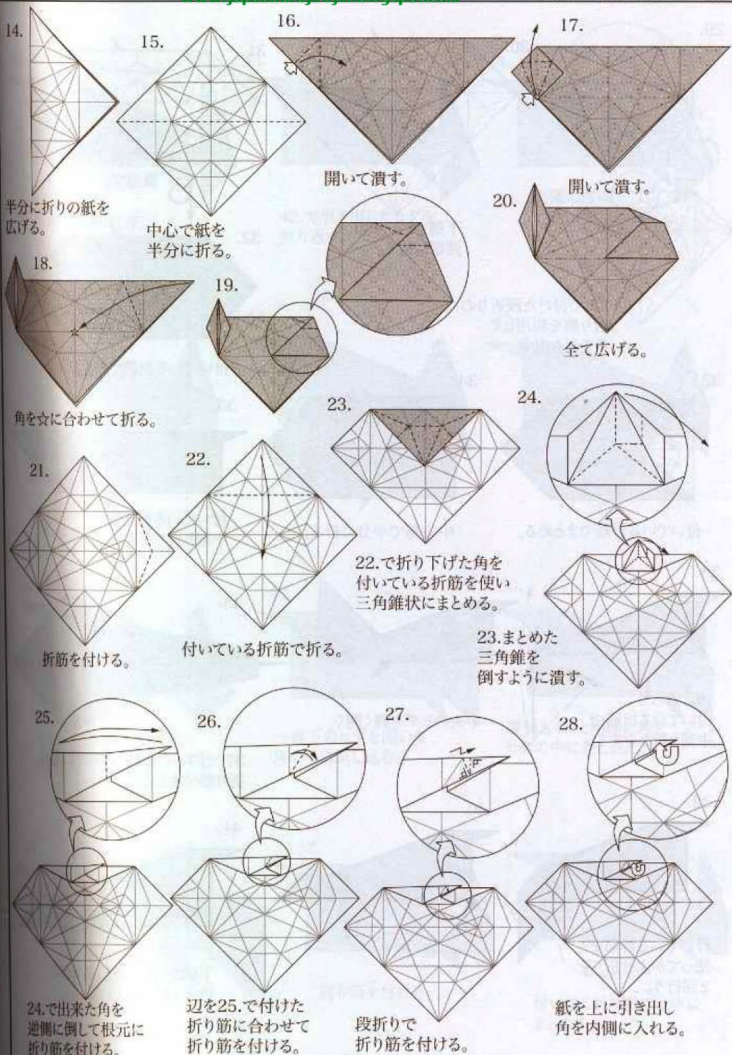

29.

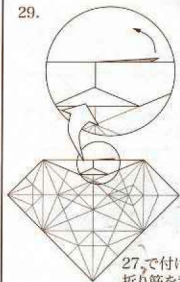

27.で付けた段折りの折り筋を利用して角を引き出す。

30.

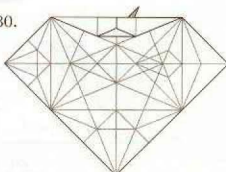

下側も22.~30.と同様に折る。

31.

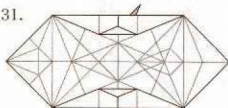

裏返す。

32.



付いている折筋で折る。

33.

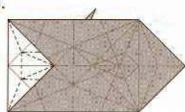

付いている折筋でまとめる。

34.



中心線で半分に折る。

35.



付いている折り筋で中割り折りをする。

36.

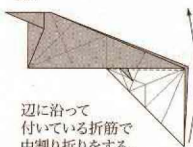

辺に沿って付いている折筋で中割り折りをする。

37.

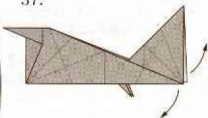

中央のヒダを軽く開く。

38.

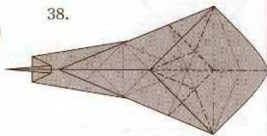

37.で開いたヒダに付いている折り筋でまとめる。

39.

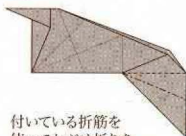

付いている折筋を使ってかぶせ折りを2回行う。

40.

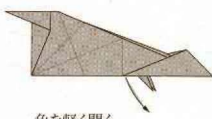

角を軽く開く。

41.

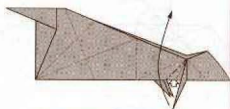

下側からヒダを開きながら角を上引き上げる。

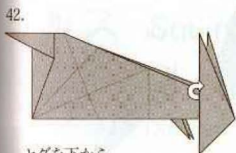

ヒダを下から  
上側に引き出します。

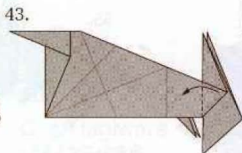

42.で引き出したヒダを  
折り返す。

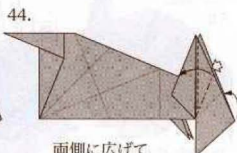

両側に広げて  
ヒダを段状にたたむ。

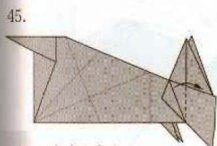

44.で出来た角を  
反対側に折り返す。

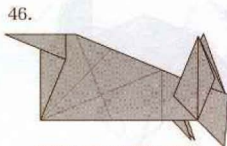

裏側も45.と同様に角を  
折り返す。

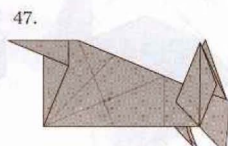

44.の状態まで戻す。

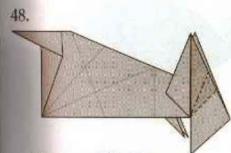

付いている折筋を使って  
段状に沈め折りをを行う。

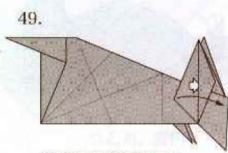

一番下のヒダを開いて  
角を中に差し込む。



裏側も49.と同様に角を  
ヒダの中に差し込む。



角を内側に  
折り込む。

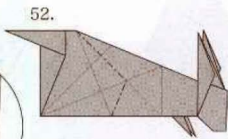

折り筋を付ける。

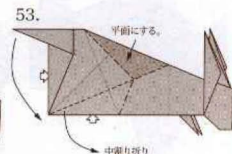

付いている折り筋で立体に  
まとめる。



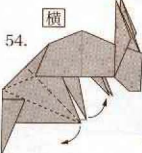

54.

角を軽く広げて沈めるように段折りをする。

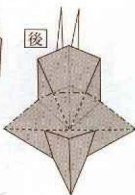

55.

角をかぶせるように折り上げる。

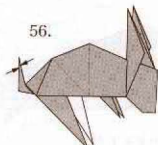

56.

ヒダを潰すようにして平らにする。

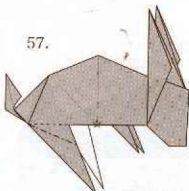

57.

辺が☆に接するように段折りをする。

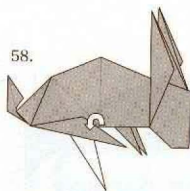

58.

57.で段折りして出来た角を隙間に差し込む。

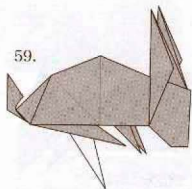

59.

反対側も57～58と同じ。

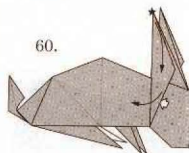

60.

ヒダを広げると同時に★の角を垂直に立てる。

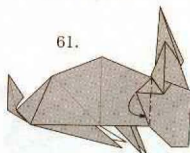

61.

付いている折筋を内側に折込む。

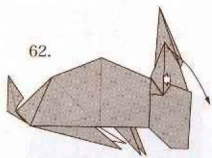

62.

60.で垂直に立てた角を開いて潰す。

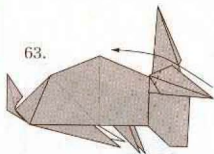

63.

ウサギの耳状に立体的に形を整える。

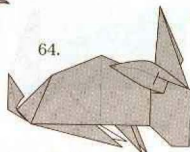

64.

反対側も63.と同様に折り耳を仕上げる。

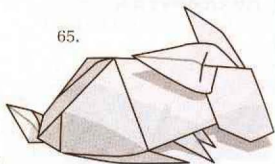

65.

出来上がり。

## リス Squirrel

創作・作図 萩原 元  
Design & Diagram Gen Hagiwara

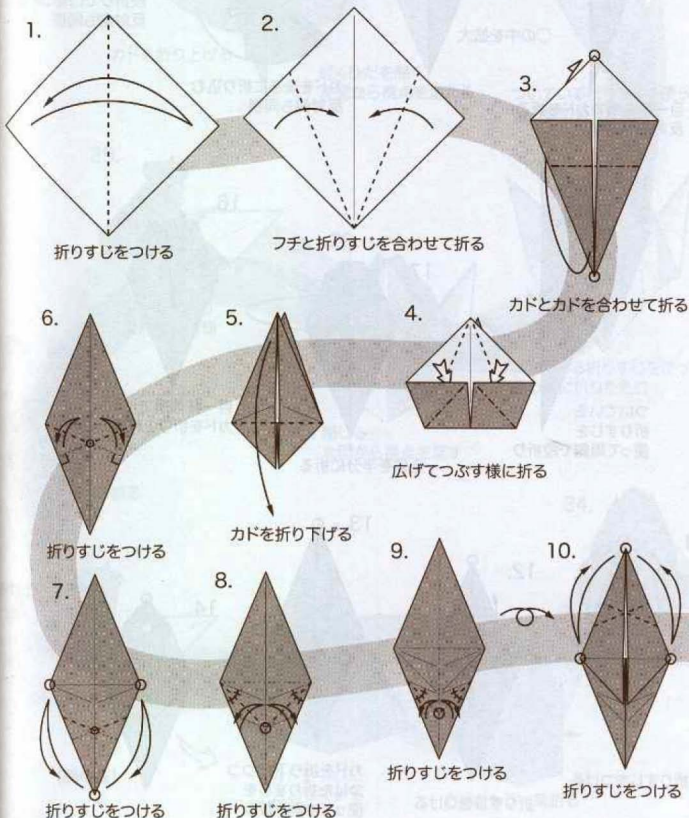
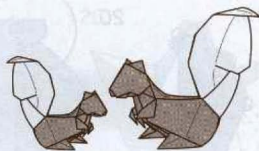

19.

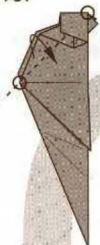

目一杯の所でカドを折る  
反対側も同様

20.



○の中を拡大

21.

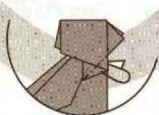

カドを後ろに折り込む  
反対側も同様

22.

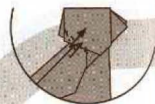

段折りで口をつくる  
反対側も同様

18.



ついている  
折りすじを  
使って両側で段折り

17.

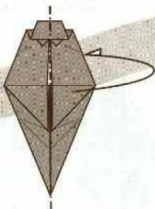

全体を半分に折る

16.

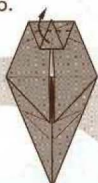

目一杯の所で  
カドを折り上げる

15.



カドを折り上げ

11.

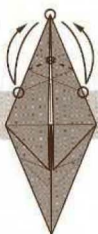

折りすじをつける

12.



折りすじをつける

13.

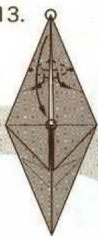

カドを折り下げつ  
つけた折りすじを  
使って中割り折り

14.

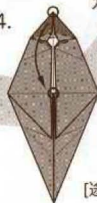

[途中図]

23.



全体図に戻る

24.



カドを折り上げる

25.

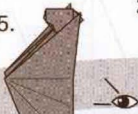

軽くひだを開く  
次図から視点を変える

26.

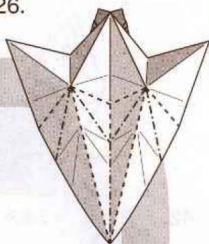

ついている折りすじを使って  
図の様に折りたたむ

29.

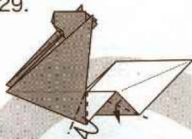

引き寄せ折り  
反対側も同様

28.

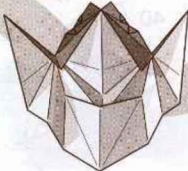

閉じる  
次図から視点に戻す

27.

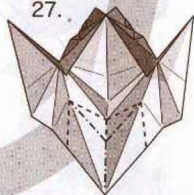

ついている折りすじを使って  
図の様に折りたたむ

30.

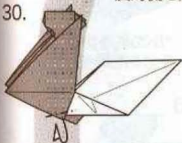

カドをうしろに折る  
反対側も同様

31.

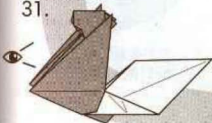

次図から視点を変える

32.

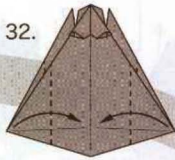

カドを中心に  
合わせて折る

33.

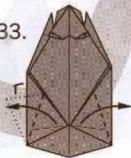

カドをもう一度折る

34.

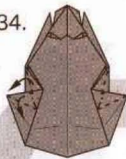

引き寄せ折り



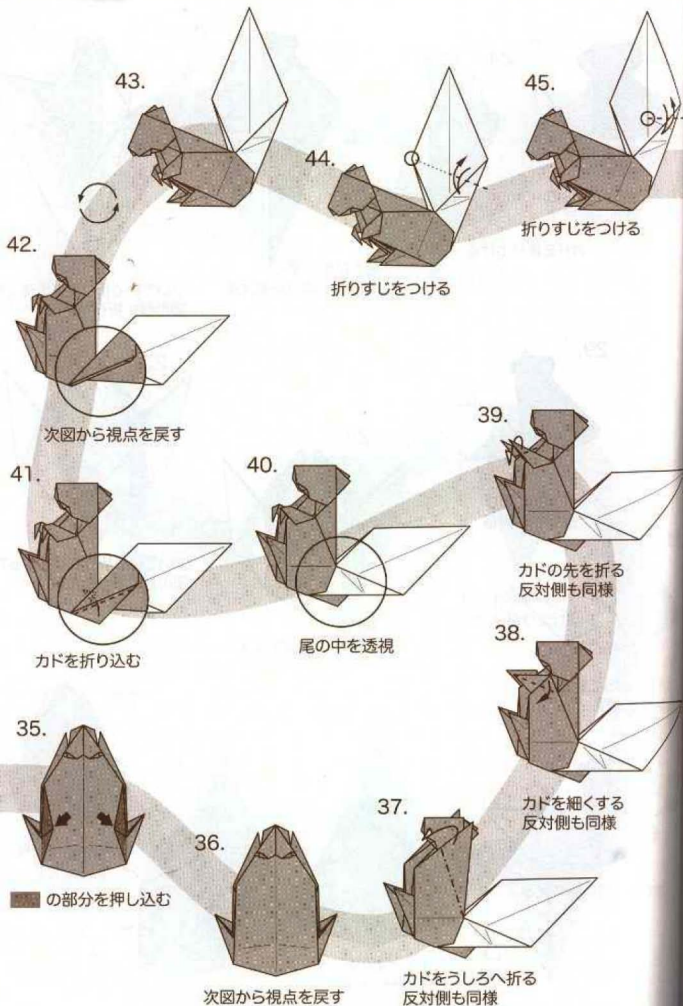

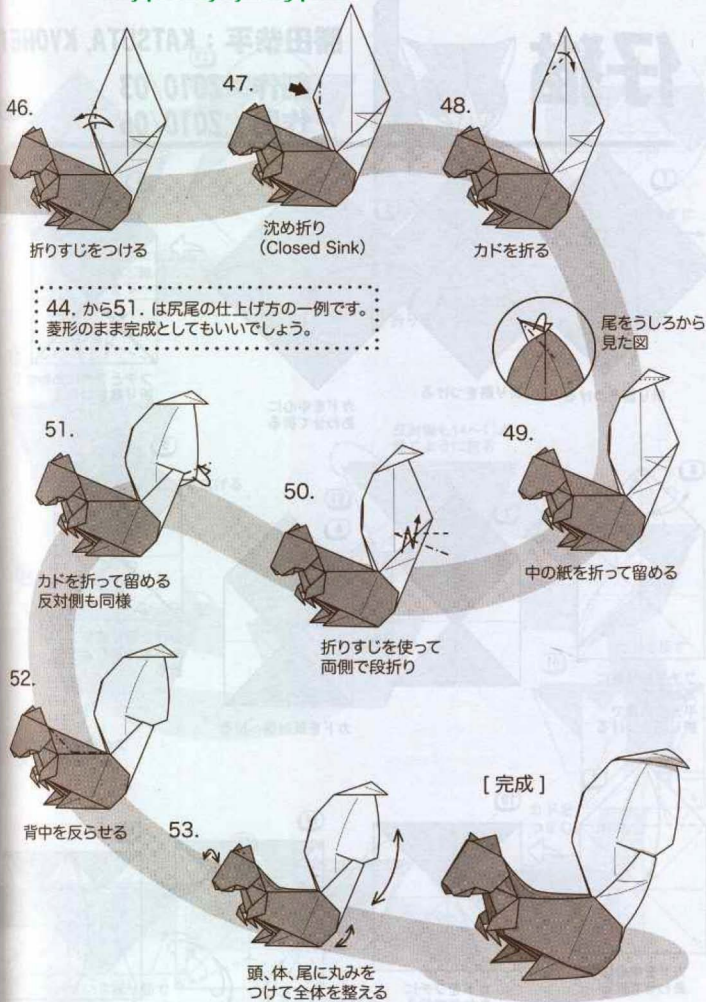

46.  
折りすじをつける

47.  
沈め折り  
(Closed Sink)

48.  
カドを折る

44. から51. は尻尾の仕上げ方の一例です。  
菱形のまま完成としてもいいでしょう。

尾をうしろから  
見た図

51.  
カドを折って留める  
反対側も同様

50.  
折りすじを使って  
両側で段折り

49.  
中の紙を折って留める

52.  
背中を反らせる

53.  
頭、体、尾に丸みを  
つけて全体を整える

[完成]

## 仔猫

勝田恭平 : KATSUTA, KYOHEI

創作 : 2010/03

作図 : 2010/06

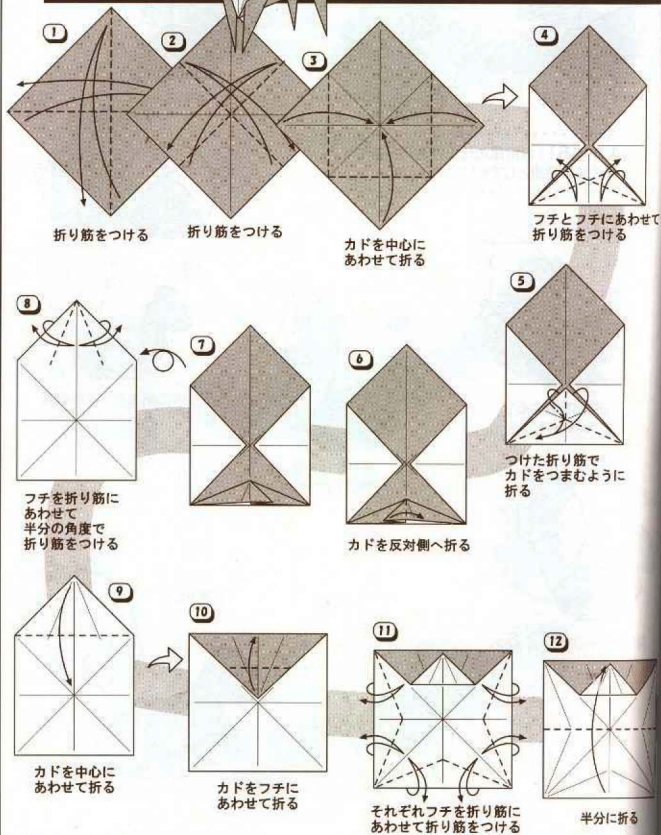

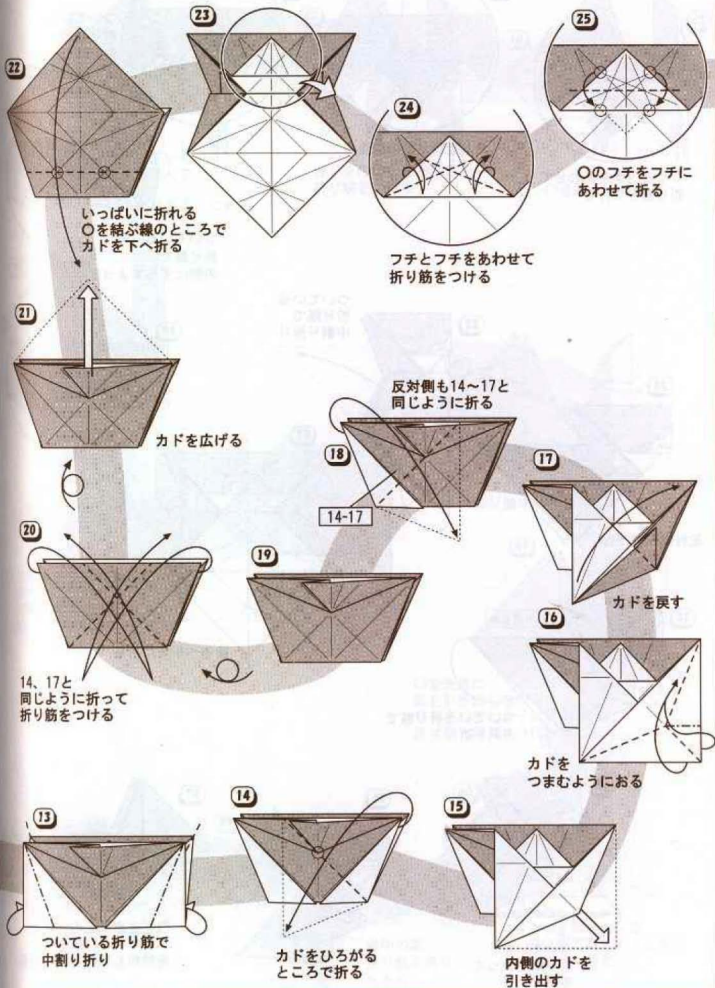



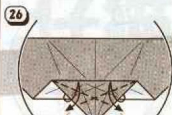

フチとフチをあわせて  
折り筋をつける

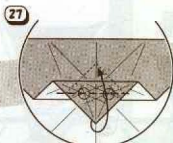

カドを折り筋の交点の  
ところで折る

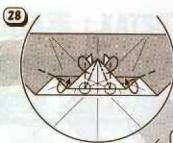

ついている  
折り筋で  
内側に  
ずらすように折る



ついている  
折り筋で  
内側にずらすように折る

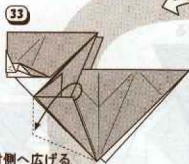

反対側へ広げる

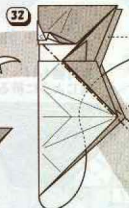

ついている  
折り筋で  
中割り折り

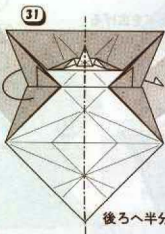

後ろへ半分折る

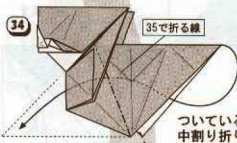

35で折る線

ついている折り筋で  
中割り折り

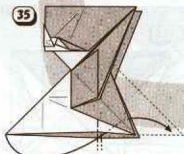

ついている  
折り筋を使って  
中割り折り

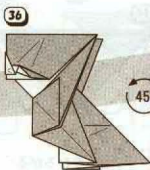

45°

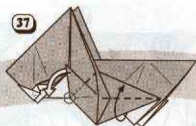

○を支点に上の一枚を  
ずらすように折る  
反対側も同じように折る

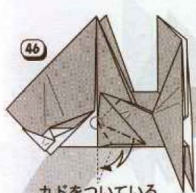

46

カドをついている  
折り筋でつまんで  
○を支点に  
フチにあわせるように折る

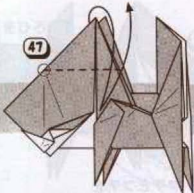

47

カドを○のところから  
折り筋をつける

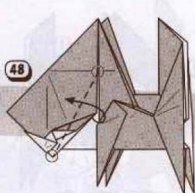

48

○を結ぶ線で折る

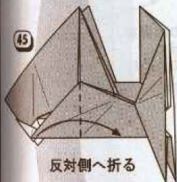

45

反対側へ折る



44

フチとフチをあわせて  
折り筋をつける  
以降49まで反対側も  
同じように折る

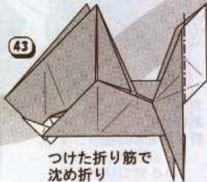

43

つけた折り筋で  
沈め折り

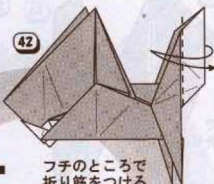

42

フチのところで  
折り筋をつける

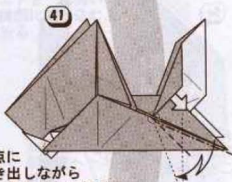

41

○を支点に  
紙を引き出しながら  
カドをつまむように折る  
反対側も同じように折る

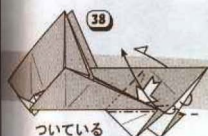

38

ついている  
折り筋で  
かぶせ折りのように折る

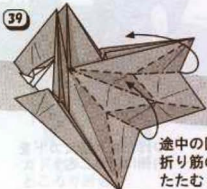

39

途中の図  
折り筋の通りに  
たたむ

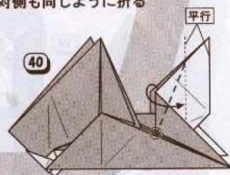

40

○のところから  
カドを斜めに折る  
反対側も同じように折る  
角度は次図で

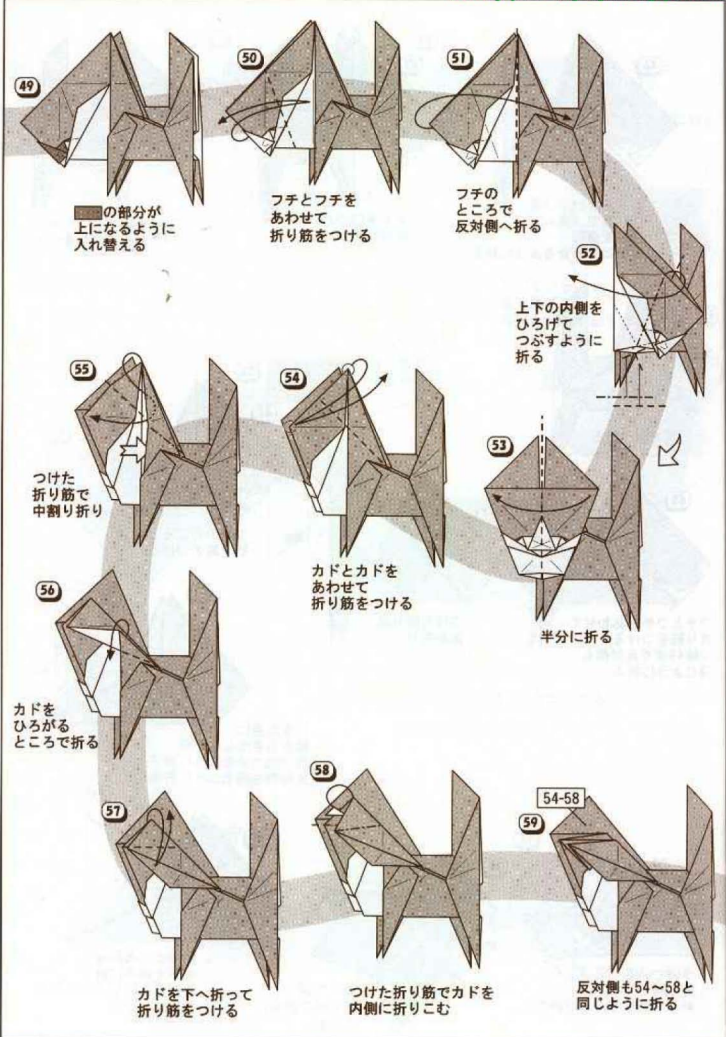

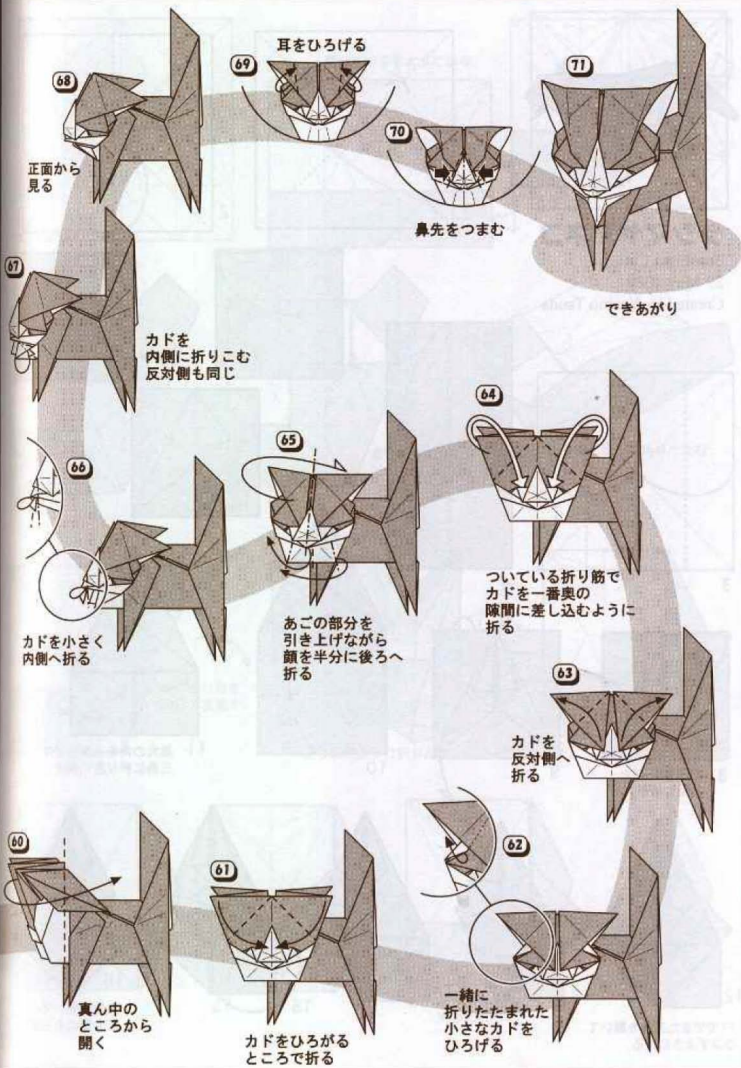

68

正面から見る

69

耳をひろげる

70

鼻先をつまむ

71

できあがり

67

カドを内側に折りこむ  
反対側も同じ

66

カドを小さく内側へ折る

65

あごの部分を  
引き上げながら  
顔を半分に後ろへ  
折る

64

ついている折り筋で  
カドを一番奥の  
隙間に差し込むように  
折る

63

カドを反対側へ折る

60

真ん中の  
ところから  
開く

61

カドをひろがる  
ところで折る

62

一緒に  
折りたたまれた  
小さなカドを  
ひろげる



ツシマヤマネコ / 津田良夫 (東京都)

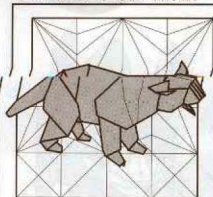

## ツシマヤマネコ

Tsushima Cat

29 May 2010

Created by Yoship Tsuda

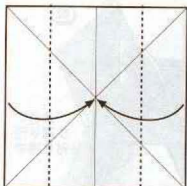
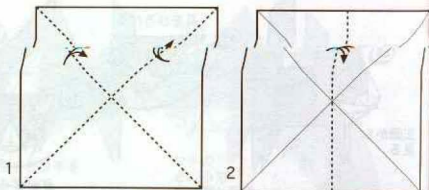

3

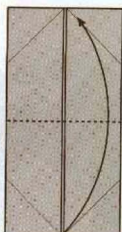

4

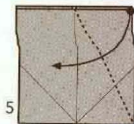

5



7

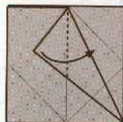

6

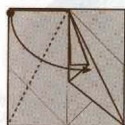

8 左側も5~7と同様に折る。

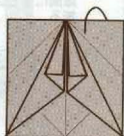

9

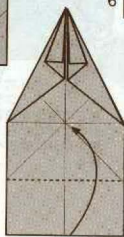

10

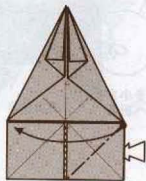

11 黒丸の角をとがらせて三角に折り左に倒す。

11

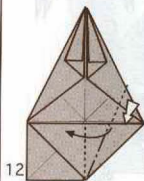

12

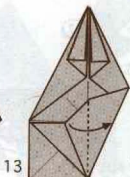

13

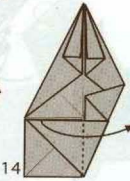

14

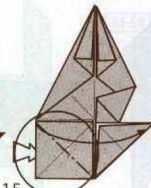

15

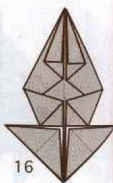

16

全体を開いて正方形にもどす。

11でできた三角を開いてつぶすように折る。

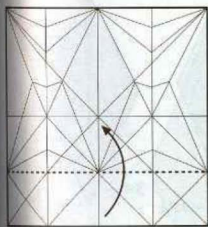

17

開いてつぶすように折る。

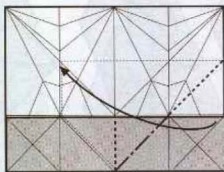

18

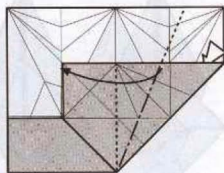

19

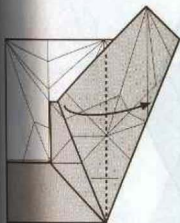

20

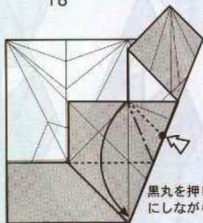

21

黒丸を押し込むようにしながら下に折る。

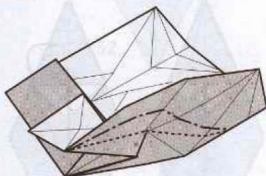

22. 折り線に沿って折りたたむ。



23

少し折り目を開いて裏返す。

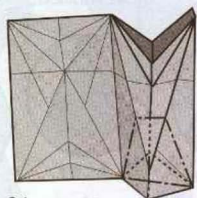

24 折り線のように折りたたむ。

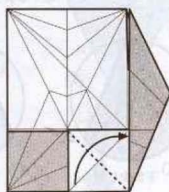

25

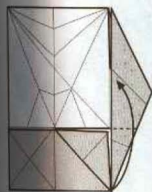

26

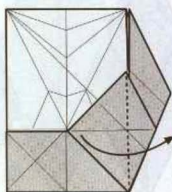

27

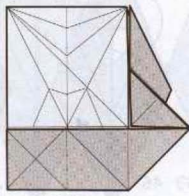

28 左半分も18~27と同様に折る。

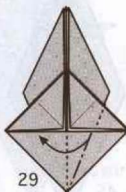

29

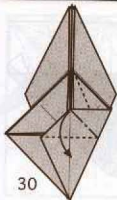

30

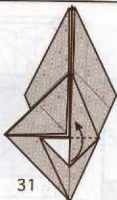

31

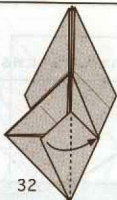

32

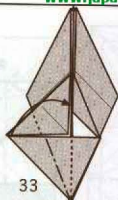

33

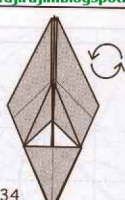

34

反対側も 29~.32 と  
同様に折る.

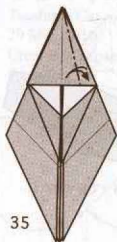

35

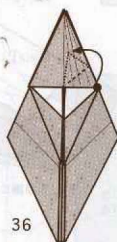

36

●が角の 1/4 線上  
にくるように折る.

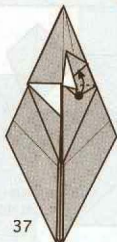

37

黒丸を押し込むように  
白三角を折りたむ.

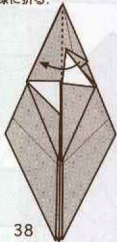

38

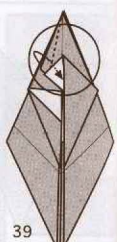

39

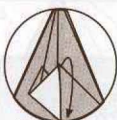

40 下に少し開く.



41 開いてつぶす.

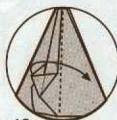

42 右に倒す.

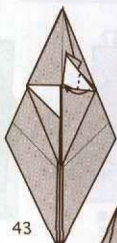

43

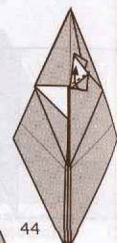

44

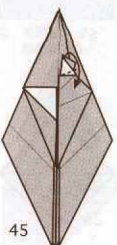

45

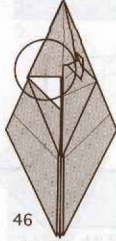

46

左の耳も 35~45  
と同様に折る.

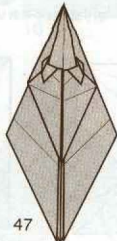

47

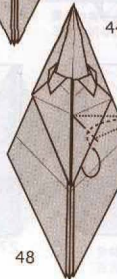

48

中わり折り

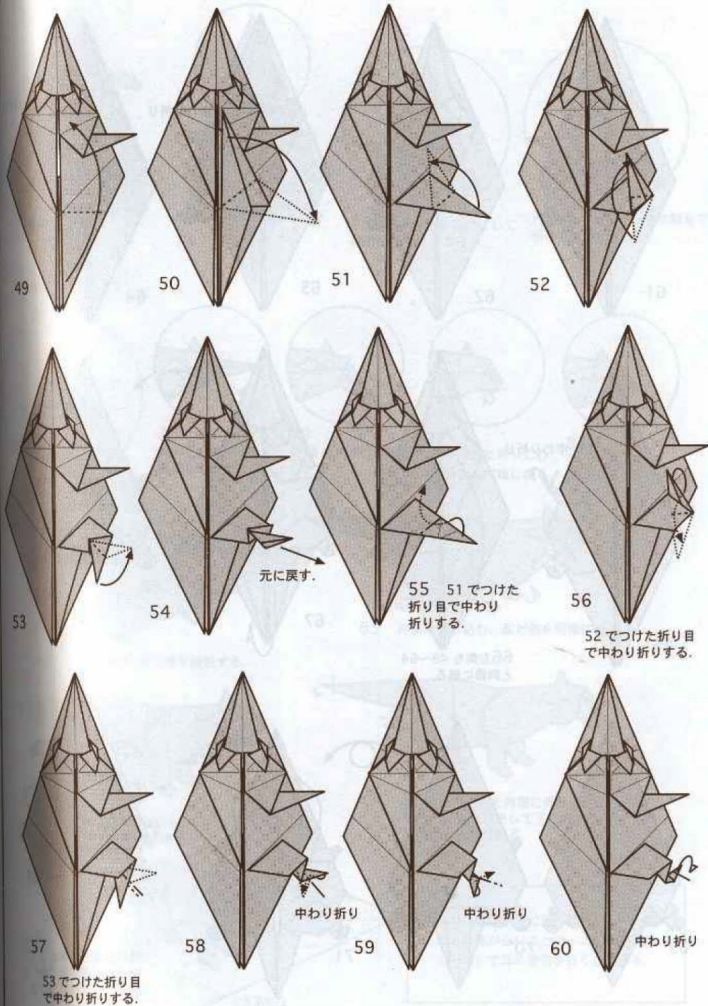



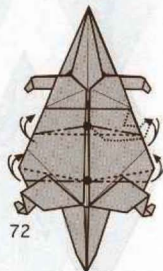
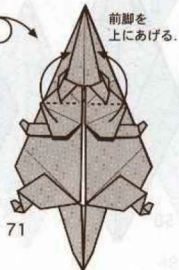
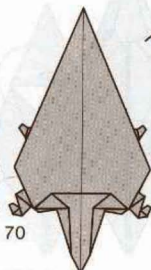
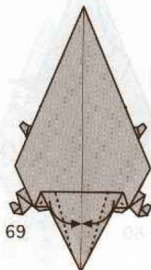
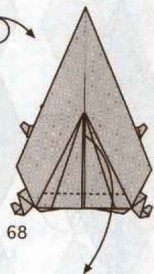
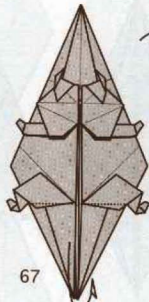
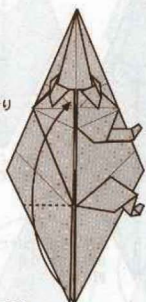
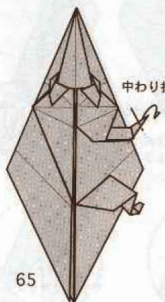
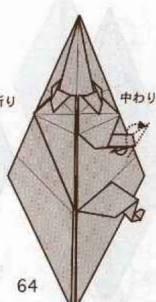
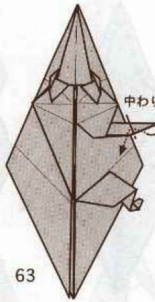
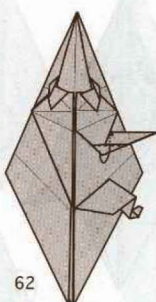
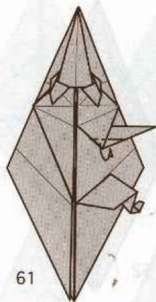

脚の位置を基準にして  
折り始める場所(●)を  
決め、折り目をつける。

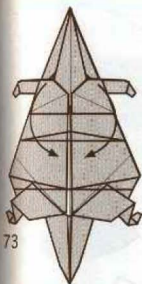

73

前脚を基にもどす。

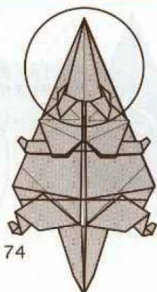

74

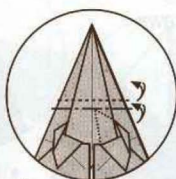

75 耳の大きさを基準にして頭部の折り目をつける。

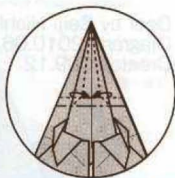

76 段折りしながら中央線まで引き寄せ折りする。



77 頭頂が裂けないように注意して頭部をカールする。

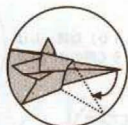

78 斜め下に向くように角度をつけて折る。



79 先端を内側に折り込む。



80

角を内側に折りこむ。反対側も同様に折る。



81

78 で折り込んだ先端部分を折り出して下顎を作る。

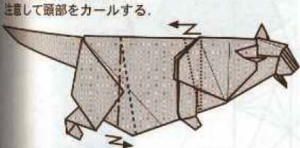

82 72 でつけた折り目で段折する。



83 内側に折り込む。反対側も同様に折る。

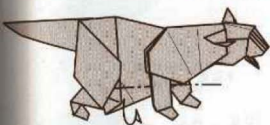

84 内側に折り込む。反対側も同様に折る。

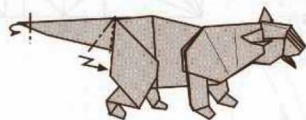

85 内尾の先端を内側に折り込む。尾の付け根を段折して下に向ける。反対側も同様に折る。

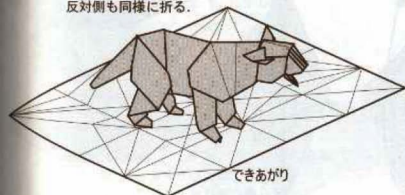

できあがり

ツシヤマネコの重要な特徴の一つは耳の裏側が白いことで、この作品では、35~46 で耳の裏側を白くしている。

シカ / 西川誠司 (東京都)

シカ 創作・作図 西川 誠司

Deer by Seiji Nishikawa  
Diagram: 2010.06.  
Create: 2009.12.

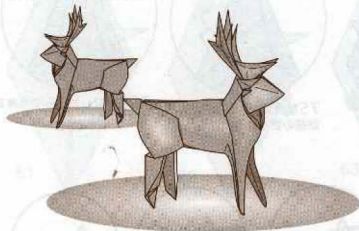

11) 角を  
折り下げる

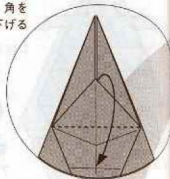

10) 以降、しば  
らく円の中の作業

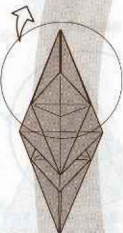

9) 裏返す

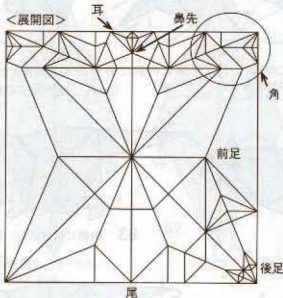

1) ツルの  
基本型から  
始めます



2) 一カ所  
つぶします

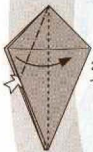

3) 裏返す



4) 反対側も  
つぶします



5) 二つのカドを  
折り上げる



6) 四つのカドを  
横に折り変える

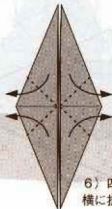

8) 折り線に  
従って内側の  
辺からカドを  
作る

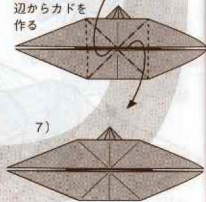

7)



© SEIJI NISHIKAWA

It is prohibited hard to improve the diagram on the web without permission.

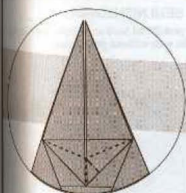
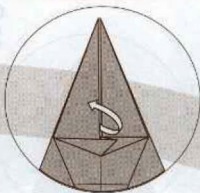
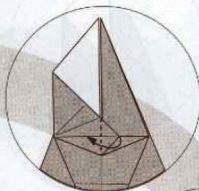
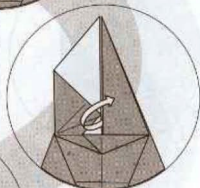
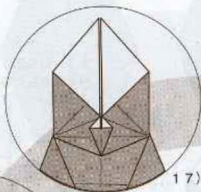
12) 山谷線に従って  
つまみ折り13) 内側から引き  
出すように14) 小さな角を  
反対側へ倒す15) 内側から  
引き出しように

17)

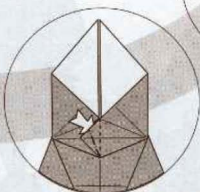
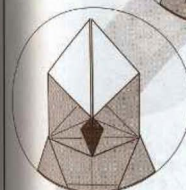
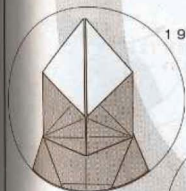
16) 小さな袋を  
つぶす18) 着色部分を  
内側へ折り変える

19) 裏返す

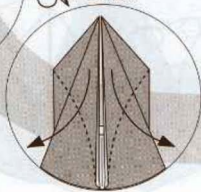
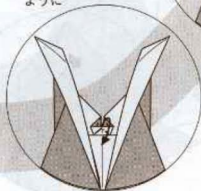
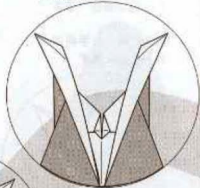
20) 手前の紙を  
内側が見えるよう  
に少し開く21) 引き寄せる  
ように22) 小さなカドを  
下に仕舞う



© SEIJI NISHIKAWA

It is prohibited hard to improve the diagram on the web without permission.

31) 30で引き出したカドを上  
に折り上げる

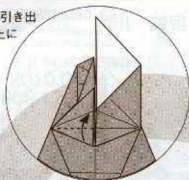

32) 反対側も  
25-31と同様に

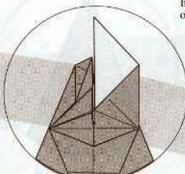

33) 谷線をしっかり  
折りすじを付ける

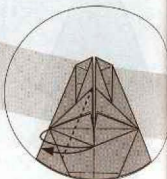

30) 上のカドを  
細く折る  
白矢印に従って  
内側のカドを  
手前に引き出す

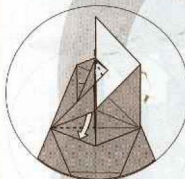

27) 白矢印に  
指を入れ広げる  
ように

28)

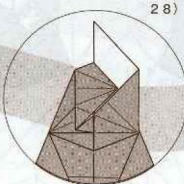
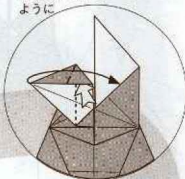

29) 矢印のカドの動きに  
注意して山谷線に従ってま  
とめる

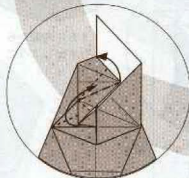

23) 開いた手前の  
カドを元に戻す

26) 白矢印に  
指を入れ広げる  
ように

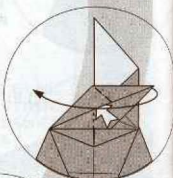

24) 裏返す

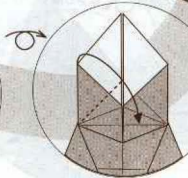
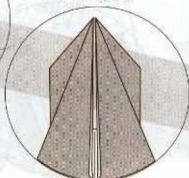
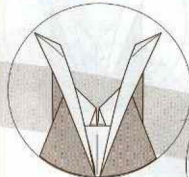

25) カド全体を  
手前に折り下げる

© SEIJI NISHIKAWA

It is prohibited hard to improve the diagram on the web without permission.

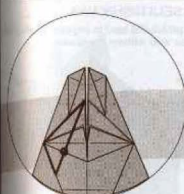

34) 太線で囲んだ部分を  
沈め折り  
○の部分は closed sink  
他は open sink

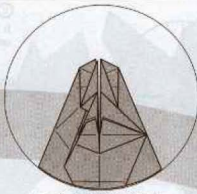

35) 反対側も 34 と  
同様に

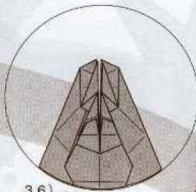

36)

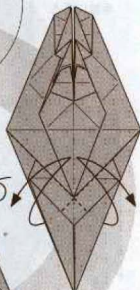

37) 手前の  
線に沿って、  
折りすじをつ  
ける



40) 山線で  
後ろにしっかり  
折り込む

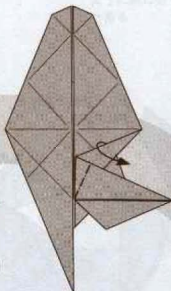

39) 手前の山線を  
折りながら後ろの部  
分を折り下げる

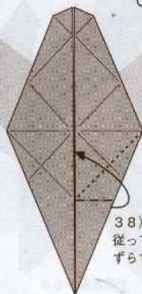

38) 山谷線に  
従ってカドを  
ずらすように

41) 小さなカドを  
後ろに折り込む  
谷線で折りすじを  
つける

42) 反対側も  
38 - 41 と同  
様に

43) 裏返す

44) 41 でつけた  
折りすじに向かって  
カドを折る

45) 谷線に従って

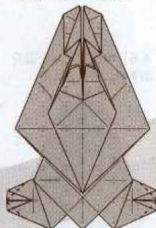
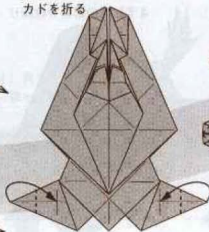
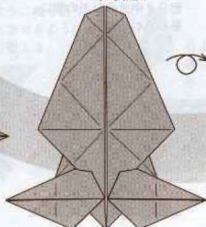

© SEIJI NISHIKAWA

It is prohibited hard to improve the design on the web without permission.

5 4) 耳を  
手前に折る



5 5) 角の先を後ろに  
倒すように山谷線に従  
って折る

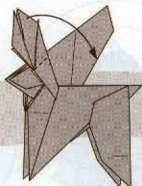

5 6) 山谷線に従って  
段折り

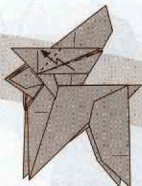

5 3) 山線で折った  
部分を後ろのひだに  
差し込む



5 2) 谷線で全体を  
手前に折る

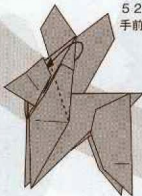

5 1) 角のカドを山線  
に従って後ろに折る



5 0) 全体を中央で半分  
に折り、山谷線に従ってま  
とめる

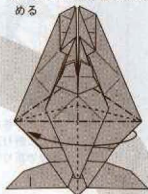

4 6) 矢印で示した辺の  
山を谷に折りがえる

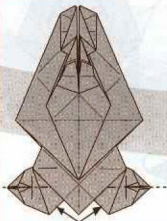

4 7) 尾の部分を段折り

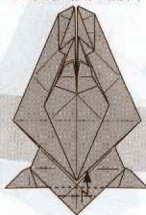

4 8) 図の要領で折った  
部分を中央のひだの間に  
差し込む

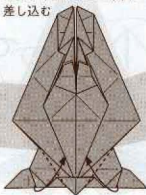

4 9)

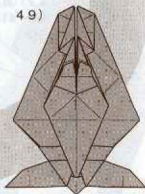

© SEIJI NISHIKAWA

It is prohibited hard to improve the diagram on the web without permission.

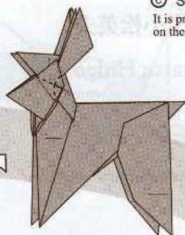
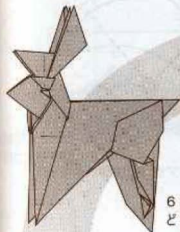
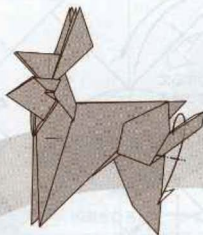
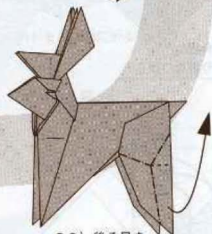
57) 耳のカードを上  
折り上げる58) 反対側も  
51-57と同様に59) 耳をつまむ  
ように前に折りま  
とめる59) 耳を後ろへ  
引き上げる62) 反対側も  
どのように61) 足先を下へ  
折り下げる60) 後ろ足を  
つまむように細くする63) 前足を2本同時  
につまむように細く折り、  
胸を膨らませるように  
立体的に整える64) 角を山谷  
線に従って整え  
る

できあがり



## うさぎ 2 🐾 小松英夫

"Rabbit 2" by Komatsu Hideo

頭に物をのせた写真で有名な、

「うさぎのウーロン」をモデルに創作しました。

参考 URL 「うさぎのページ」:

<http://www.fsinet.or.jp/~sokaisha/rabbit/rabbit.htm>

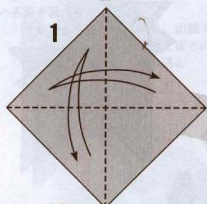
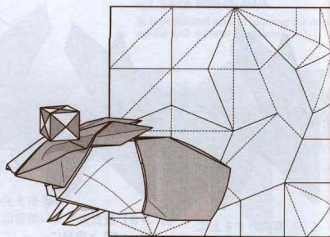

1  
対角線に  
折り筋をつける



2  
辺の中心に  
印をつける

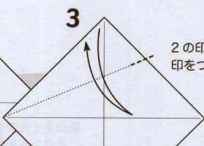

3  
2の印の対辺に  
印をつける

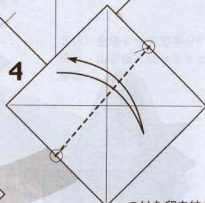

4  
つけた印を結んで  
折り筋をつける

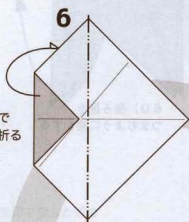

5  
対角線で  
後ろへ折る

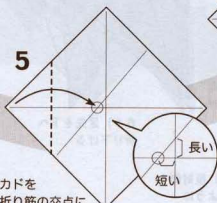

6  
カドを  
折り筋の交点に  
合わせて折る

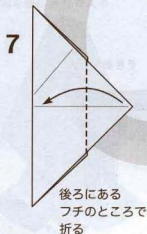

7  
後ろにある  
フチのところで  
折る

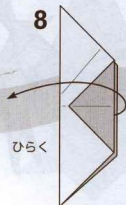

8  
ひらく

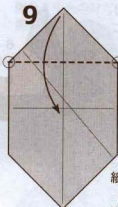

9  
紙の向き  
(折り筋の位置)に  
注意してカドを折る



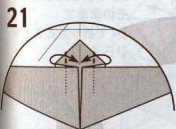

21 ついている折り筋でカドを谷折り (フチの下で折る)

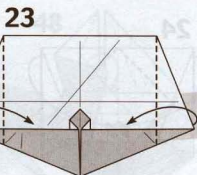
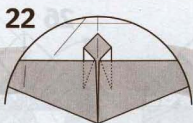

23 ついている折り筋で折る

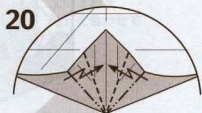

20 山谷を逆にして折りたたむ

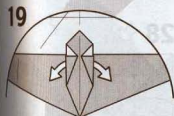

19 ひらく

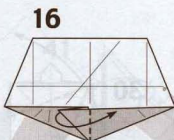

16 カドを反対側に折る

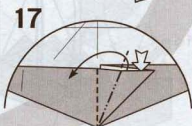

17 内側をひろげてつぶす

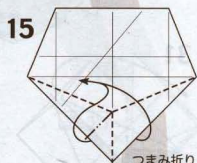

15 つまみ折り

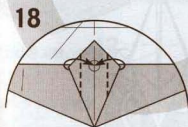

18 カドを折り筋に合わせて折る

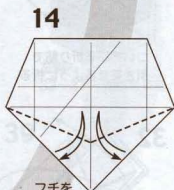

14 フチを折り筋に合わせて折り筋をつける

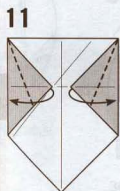

11 フチを合わせて折る

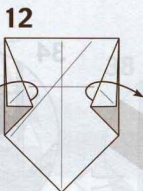

12 ひらく

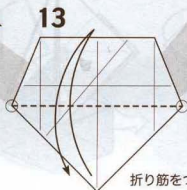

13 折り筋をつける

24

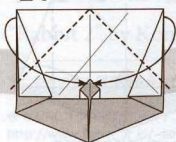

フチを中心線に  
合わせて折る

25

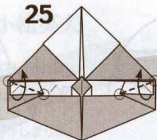

ひっかかるところで  
折るとフチがそろろう

26

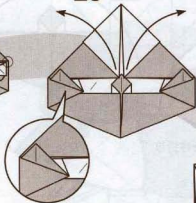

25で折ったところは  
そのまま  
24で折ったところを  
ひらく

27

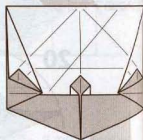

30



後ろにある  
フチに沿って折る

29



ついている折り筋で  
下に折る

28

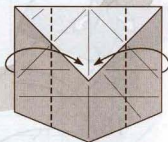

フチを中心線に  
合わせて折る

31

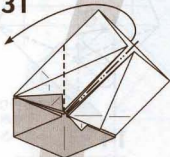

ついている折り筋で  
引き寄せるように折る

32

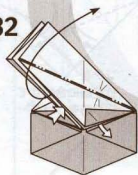

紙の重なりを外して  
上のカドをひらくように  
折たたむ

33

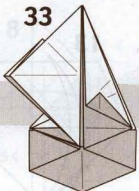

34



○のカドが中心線にのるように  
ずらして折る

35



内側の紙を引き出す



46



上の1枚を  
カドを合わせて  
折る

47

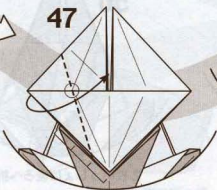

○を通る線で斜めに折る

48

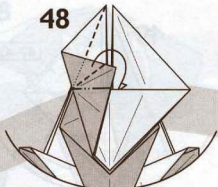

フチのところ  
で内側に折り込む

45



44

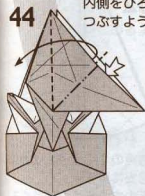

内側をひろげて  
つぶすように折る

41

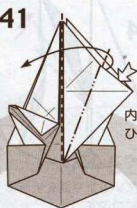

内側を  
ひろげてつぶす

42



花弁折り

40

32-37



左側も  
32~37と同様に折る

43



重なっている紙を  
はがして  
折りたたみ直す

36



カドの先を  
少し残して折る

37



36と同じくらいの  
幅ですらすらように折る

38



39

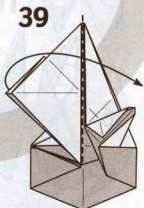

折り返す



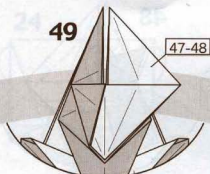

49  
右側も 47~48 と  
同様に折る

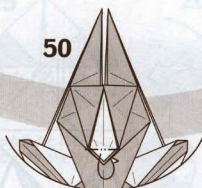

50  
2枚いっしょに後ろへ折る

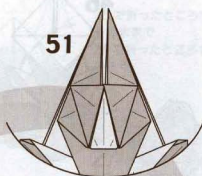

51

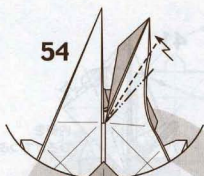

54

ついている折り筋を使って  
平らにつぶす

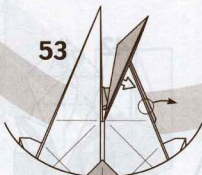

53

白い層 2枚を持って引き出す

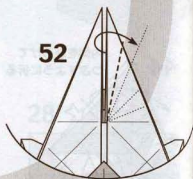

52

直角の 1/8 くらい  
の角度を目安に折る  
下の方の紙が  
つれてくる  
部分は  
つぶす

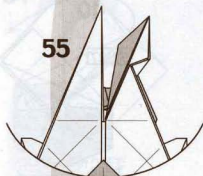

55



56

後ろにかぶせるように  
折り変える



57

(途中の図)  
カドの根元まで  
きちんと折る



58

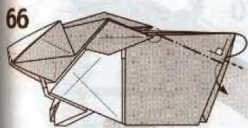

中割り折り



胴体に  
十分な丸みをつける

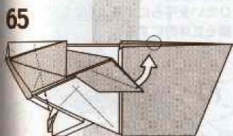

耳のカドが  
背中の線にのるようにずらす



内側で折って  
留める

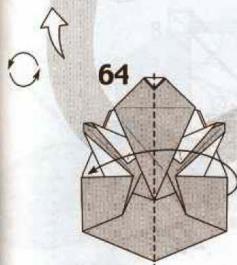

64

半分に折る



63

頭部を後ろに折り返す

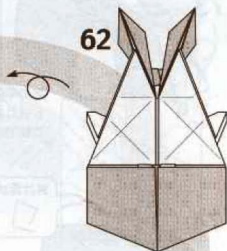

62



左側も 52~58 と同様に折る

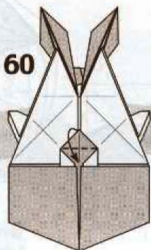

60

カドを結ぶ線  
で折る



61

奥のすき間に  
差し込んで留める

69



胴体の断面イメージ

70

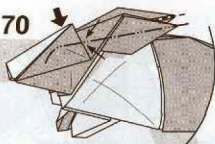

耳のつけ根をつまんで半分に山折りする  
これを両耳で行い  
ひたいを平らにするようにして  
顔を立体的にする

72 71を斜め前から  
見たところ

ひたいを平らにする  
台形を意識

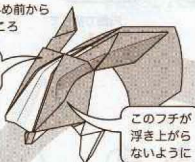

このフチが  
浮き上がら  
ないように

71

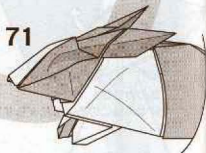

73



耳の下側の層だけ  
谷折りに変えて  
立体的にする

77

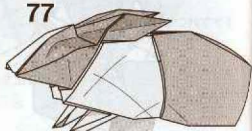

できあがり

74



耳は筒状になる

75



足を立体的に  
半分に折る  
体の内側で  
つれたようになっていい  
向こう側も同じ

76

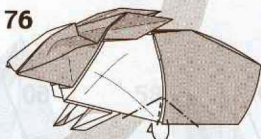

体の脇を少しへこませるようにして  
形を整えて仕上げる  
向こう側も同じ

■立体的な仕上げについては  
<http://origami.gr.jp/~komatsu/gallery/rabbit2.htm>  
で公開している完成写真も参考にしてください。



## クマ Bear

福田 亨 Fukuda Toru

制作: 2010/1/24 作図: 2010/3/28

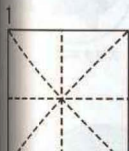
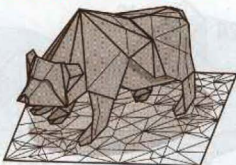

折り筋をつける

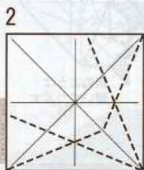

折り筋をつける

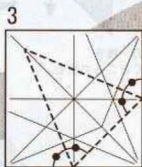

折り筋をつける

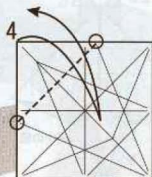

○を結ぶ線で  
折り筋をつける

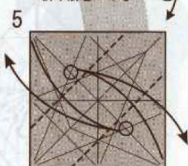

カドを○にあわせて  
折り筋をつける

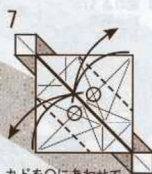

カドを○にあわせて  
折り筋をつける

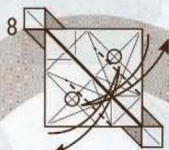

カドを○にあわせて  
折り筋をつける  
(斜めの折り筋の  
交点までつける)



開く



○を通る線で  
折り筋をつける

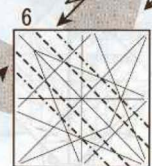

つけた折り筋を  
使って段折り

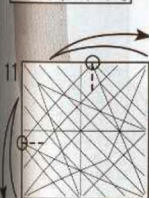

○の位置から  
図のように  
折り筋をつける

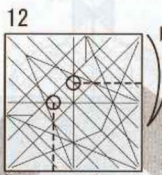

○の位置から  
折り筋をつける

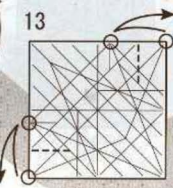

○と○をあわせて  
図の位置だけ  
折り筋をつける

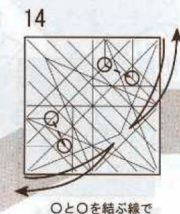

○と○を結ぶ線で  
折り筋をつける



15 図の位置だけ折り筋をつける (○の線と折り筋をあわせて折ると折りやすい)

16 ○の位置から折り筋をつける

17 ○と○を結ぶ線で折り筋をつける

18 カドを○にあわせて折印をつける

19 カドを印にあわせて折る

20 つまみ折り

21 段折り

22

23 中割り折り (完璧には折れず立体な状態になる)

24 図のように折り筋でたたむ。

25 途中の図

26 上の一枚を開くところで折る

27 図のように開いてつぶす

28

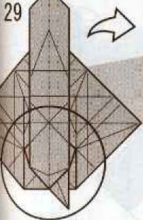
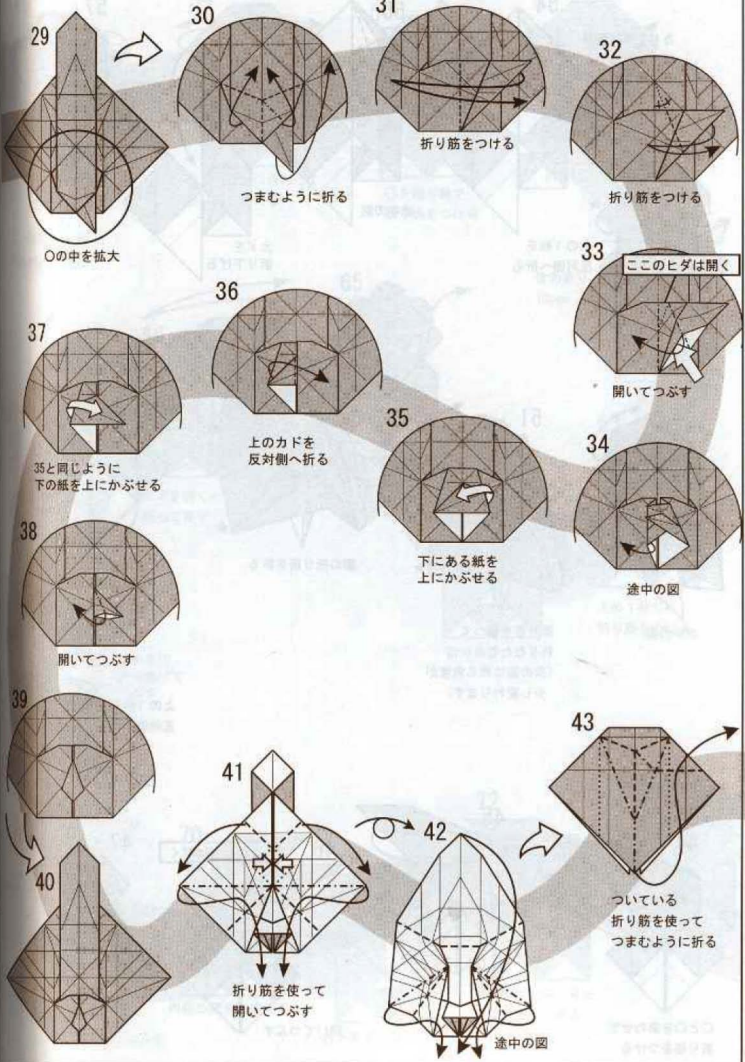

○の中を拡大



つまむように折る

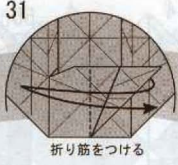

折り筋をつける



折り筋をつける



このヒダは開く

開いてつぶす

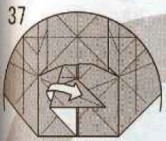

35と同じように  
下の紙を上にかぶせる



上のカドを  
反対側へ折る

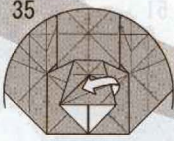

下にある紙を  
上にかぶせる

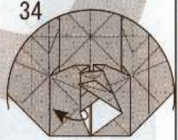

途中の図

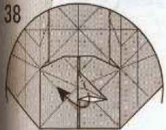

開いてつぶす

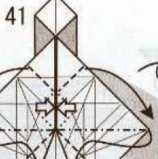
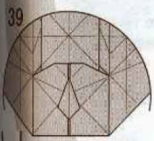

折り筋を使って  
開いてつぶす



途中の図

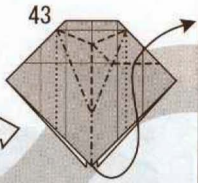

ついている  
折り筋を使って  
つまむように折る

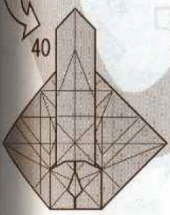

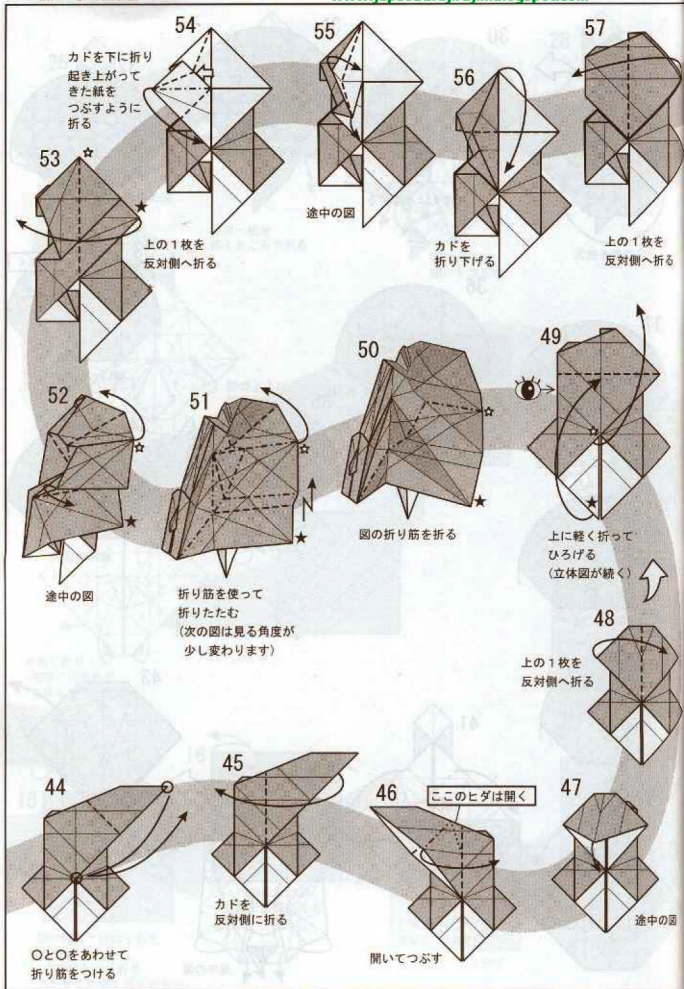





58  
反対側も47~56と  
同じように折る

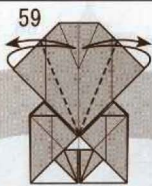

59  
縁を折り筋に合わせて  
折り筋をつける

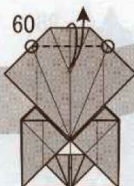

60  
○を結ぶ縁で  
折り筋をつける

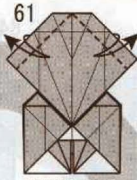

61  
折り筋をつける

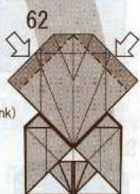

62  
沈め折り  
(Open sink)



66  
カドを開くところで  
折って戻す

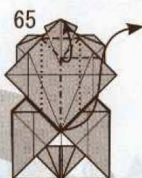

65  
つけた折り筋を使って  
折りたたむ

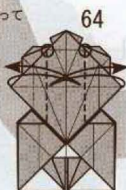

64  
折り筋をつける



63  
上の1枚だけ  
折り筋をつける



67  
すきまを軽くひろげる



68  
縁を上  
に折りあげて  
つぶす



69  
上の1枚を開くところで  
下に折り下げ

起き上がってきた紙をつぶす



70  
内側の紙を引き出す



71  
カドを反対側へ折る



72  
反対側も65~70と  
同じように折る



73  
開いてつぶす



87



カドを反対側に折る

88

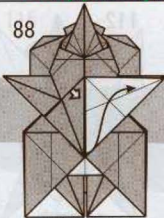

反対側も84~87と  
同じように折る

89

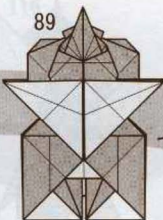

90

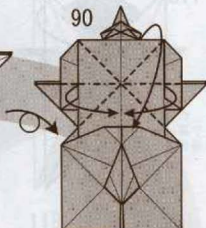

中割り折りをするように  
線を下に折り下げて  
起き上がってきた紙をつぶす

94



93



線と線をあわせるように  
中割り折り

92



カドを中心にあわせて折り  
起き上がってきた紙をつぶす

91

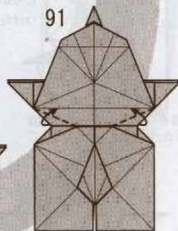

線を折り筋にあわせて折る

95

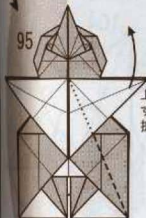

上の1枚を  
ずらすように  
折る

96



ついている折り筋を使って  
中割り折り

97

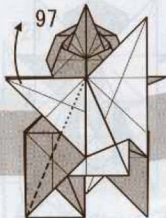

反対側も95~96と  
同じように折る

98

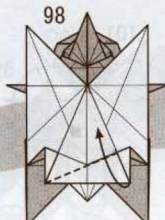

カドを開くところで折り上げ  
起き上がってきた紙をつぶす

99

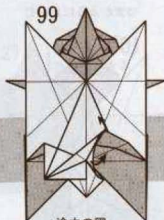

途中の図

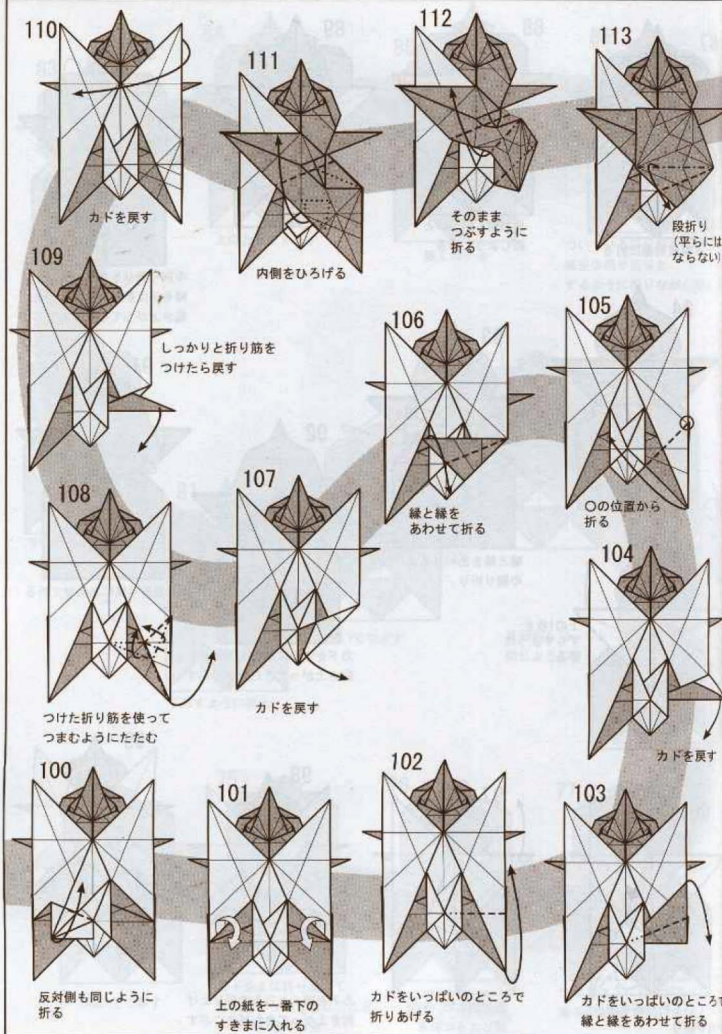

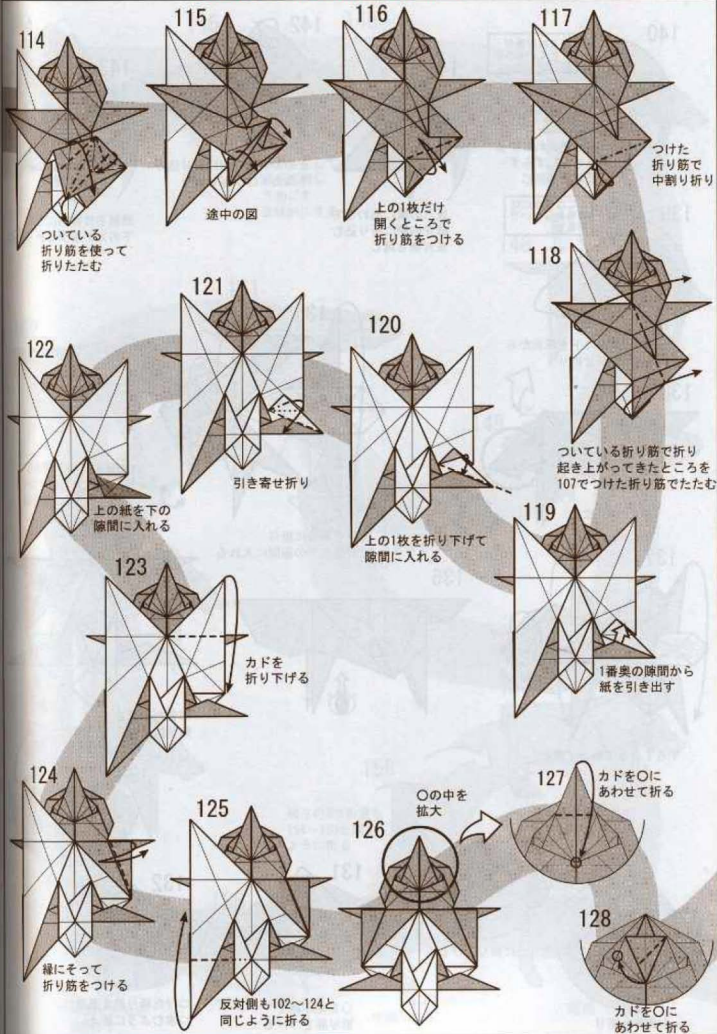



140



ここに段差が  
できているのが  
正しい

折り込まれている  
紙を少しずらす  
反対側も同じ

139



ここには完全に  
開ききらないで  
折る

上のカドを根元から  
かぶせ折り

138



拡大

137

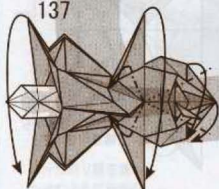

ずらすように折って畳む

141

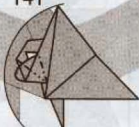

後ろの縁にあわせて  
縁を内側に折り込む  
反対側も同じ

142

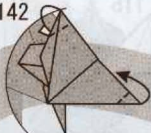

上のカドは内側に折り込み  
下のカドはかぶせ折り

143



頭部を立体的にして  
下のカドを少し折り込む

135

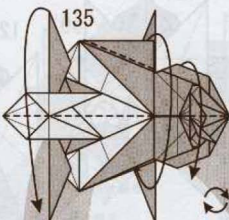

全体を半分に折り  
上の縁を下の間隙に入れる

134

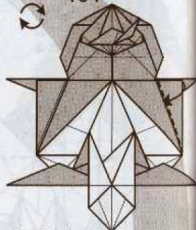

右側だけ縁を  
隙間に入れる

136



133

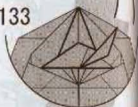

130



上に折り上げる

131

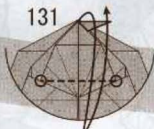

○を結ぶ線で  
折り筋をつける

132



つけた折り筋を基準に  
つまむように折る

129



引き寄せ折り





下あごの位置を調整する



紙をつぶして目を表現し下あごを立体的にする

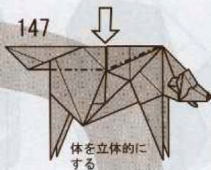

体を立体的にする

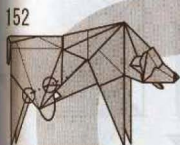

○を結ぶ線で線を2枚一緒に後ろへ折り込む反対側も同じ



緑を後ろへ折り垂直に立てる(次から視点を戻す)

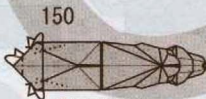

緑とカドを後ろへ折り込む

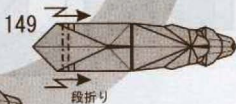

段折り

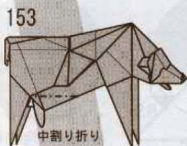

中割り折り



拡大



残りの3つの足も154~156と同じように折る

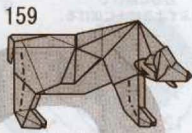

足を立体的にして耳を軽く立てる

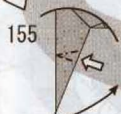

中割り折りを2回行う



1枚だけ紙を引き出す



中割り折り



完成

# ふくろう "Owl ver. 2"

20 February 2010 津田良夫 Yoshio Tsuda

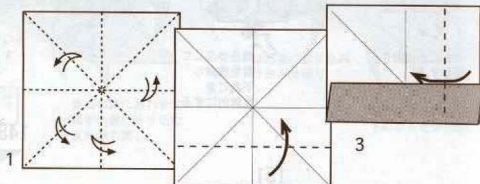

1

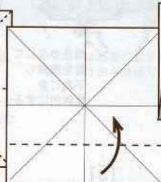

2

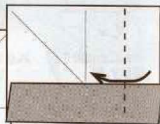

3

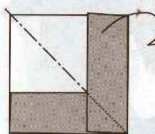

4

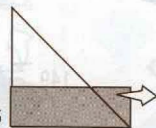

5



6

裏側も同様に折る。

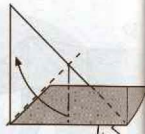

7  
開いてつぶす。

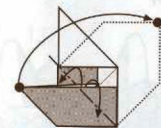

8 左右に開いて  
つぶすように上に広げる。

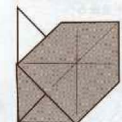

9

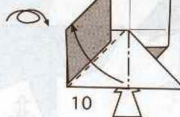

10

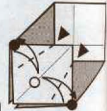

11  
折り始めの位置に  
気をつけて折り筋を  
つける。

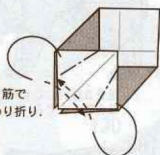

12  
折り筋で  
中わり折り。

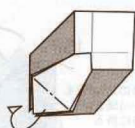

13  
(12)で折りこんだ  
角を包み込むように  
折りこむ。

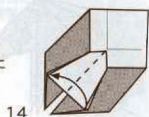

14

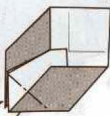

15

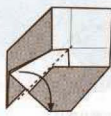

16

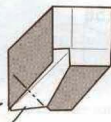

17

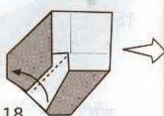

18



19 影の部分が正三角形になるように折る。

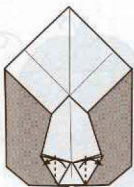

20

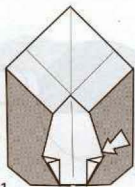

21 隙間を開いて重なっている部分はずす。

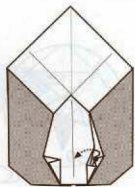

22 黒丸の角を中に折り込む。



23 巻き込むように中に折り込む。

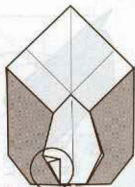

24 反対側も同様に折り込む。

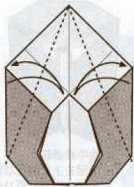

25

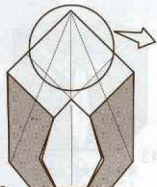

26

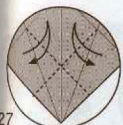

27 裏返して先端を折る。



28

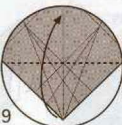

29

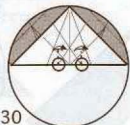

30

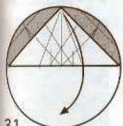

31



32

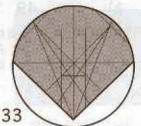

33



34 太線は山、点線は谷になるように一度に折る。

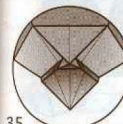

35

影の部分は内側に折り込まれる。

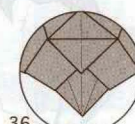

36



37



38

39

40

41

42

43

44

45

46

47

48

49

50

51

52

53

54

途中経過図。  
頭部を上を開きながら  
全体を半分折りたたむ。

手前の隙間に  
折り込む。

反対側も同様に折り込む。

隙間を広げつつ黒丸を押し  
上げて折り目をつける。

反対側も同様に折る。

内側に指を入れてお腹を  
ふくらませ、黒丸をつまむ  
ように下に折る。

黒丸を中央に合わせる  
ように折る。

顔を両脇を少し折る。

くちばしをつまむように  
折る。

形を整えてできあがり。



## 小鳥

Little Bird

作/図 宮島 登

Models & Diagrams By Noboru MIYAJIMA

創作/2009年 8月 作図/2009年10月

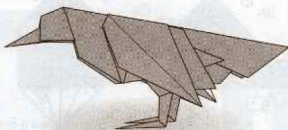

対角線で折り筋をつける

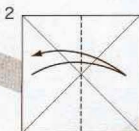

フチを合わせて  
折り筋をつける

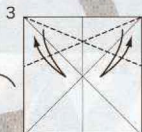

折り筋にフチを合わせて  
折り筋をつける (2箇所)

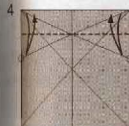

カドをOに合わせて  
折り筋をつける



カドをOに合わせて折る



フチを合わせて折る



フチを合わせて  
折り筋をつける (2箇所)



内側を広げてつぶす



カドを交点に合わせて  
折り筋をつける (2箇所)



内側を広げてつぶす



内側を広げてつぶす



半分に折る

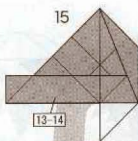

15

13-14  
左側も同様に折る  
(13-14)

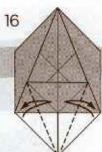

16

中心に合わせて折り筋を  
つける(2箇所)

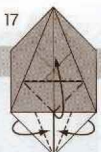

17

フチを折り上げて  
両側をたたむ

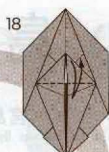

18

折り筋をつける

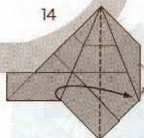

14

右側へ1枚たおす

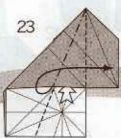

23

内側を広げてつぶす

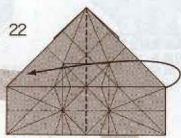

22

左側へ1枚たおす



19

12の状態まで戻す

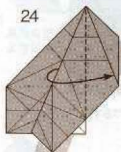

24

右側へ1枚たおす



20

重なっている部分を広げる

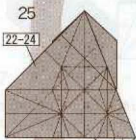

25

22-24

左側も同様に折る  
(22-24)



21

内側を広げてつぶす

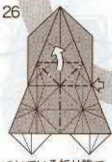

26

ついている折り筋で、  
中心を引き上げるよう  
に折る

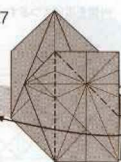

27

内側を広げてつぶす

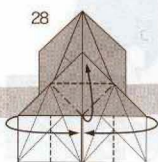

28

フチを折り上げて  
両側をたたむ



29

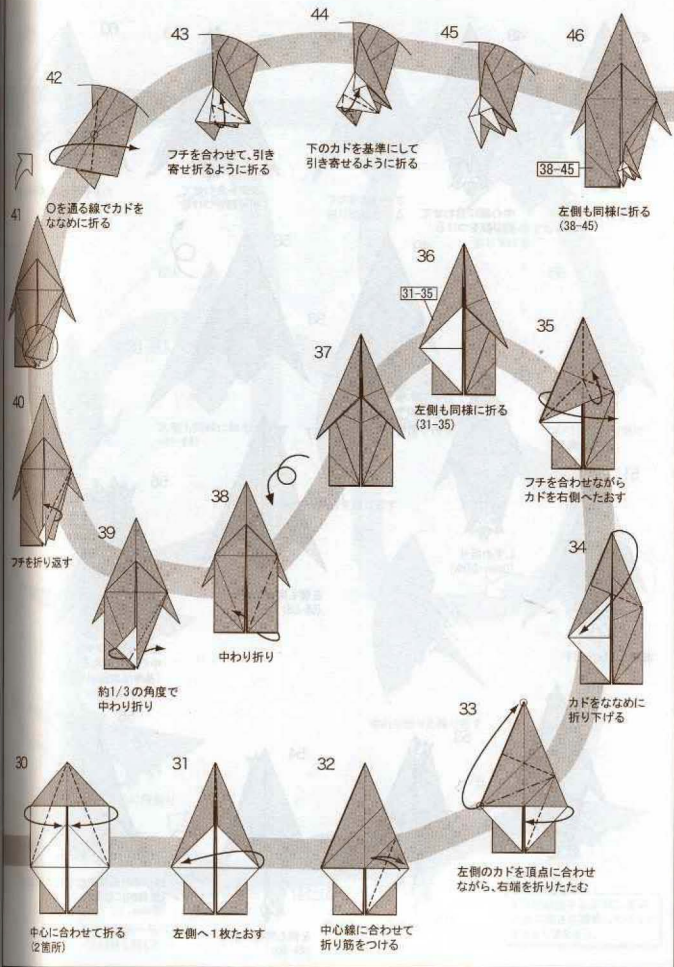

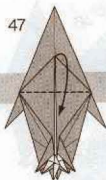

47 カドを折り下げる

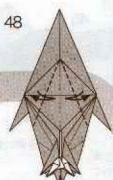

48 中心線に合わせて  
折り筋をつける

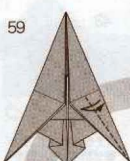

59 フチを合わせて  
折り筋をつける

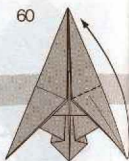

60 カドを折り上げる

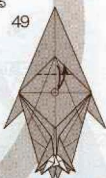

49 カドを○に合わせて  
折り筋をつける

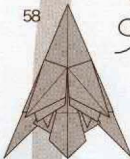

58



50 しずめ折り  
(Open Sink)

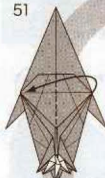

51 左側へ1枚たおす

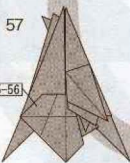

57 左側も同様に折る  
(55-56)

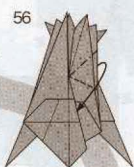

56 段折りしてフチを  
中心線で揃える  
(基準は次回参照)

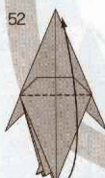

52 カドを折り上げる

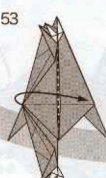

53 右側へたおす

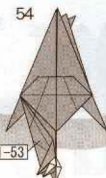

54 左側も同様に折る  
(48-50)

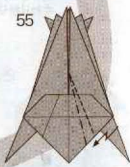

55 約1/3の角度でななめに段折り  
(立体的になる)



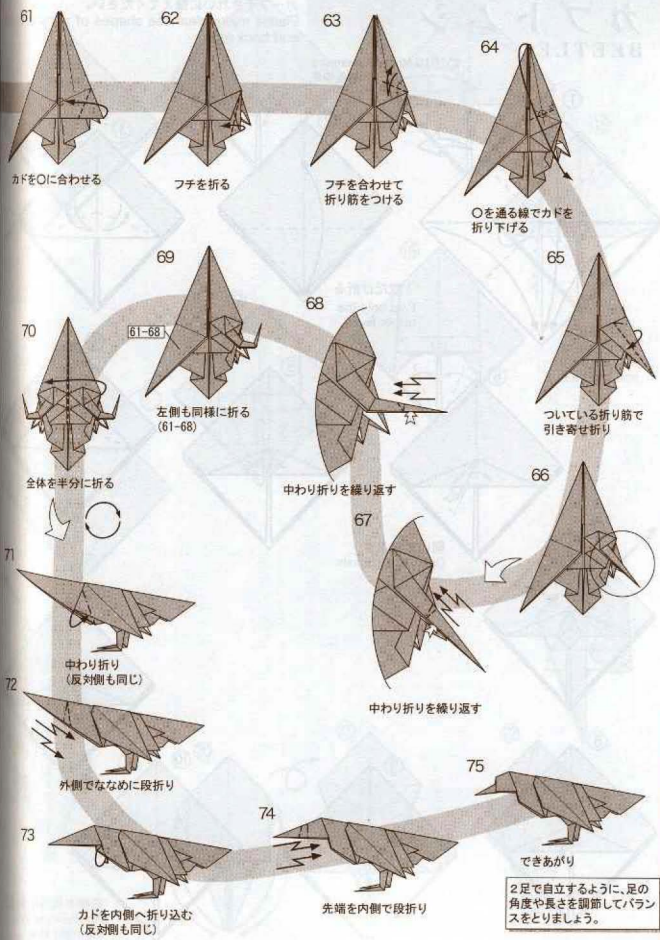

2足で自立するように、足の角度や長さを調節してバランスをとりましょう。

カブトムシ / 川村みゆき (佐賀県)

Design : 20090815

## カブトムシ BEETLE

©2010 Miyuki Kawamura  
川村みゆき

背中の丸みと、腹側から見た後ろ足の付け根のカーブをきれいに整えてください。  
Please make clear the shapes of curved back and back legs.

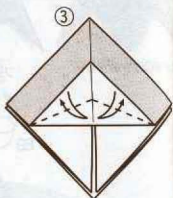
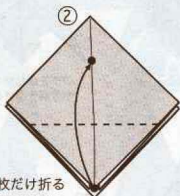
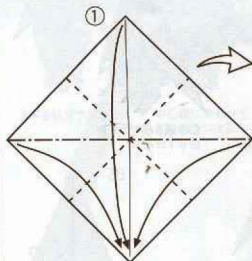

1枚だけ折る  
Fold only the  
upper layer.

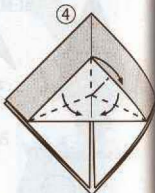
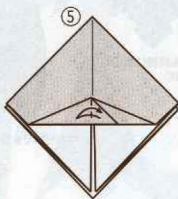
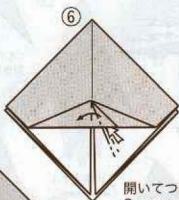

開いてつぶす  
Open and squash.

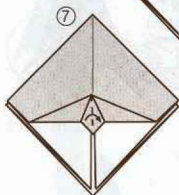

## Japão Burajirujin

www.japaoburajirujin.blogspot.com

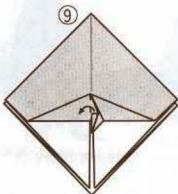
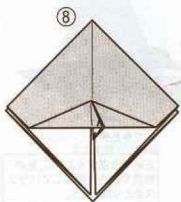
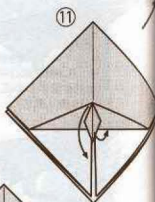

右側も同様に折る  
Do the same on the  
right side.

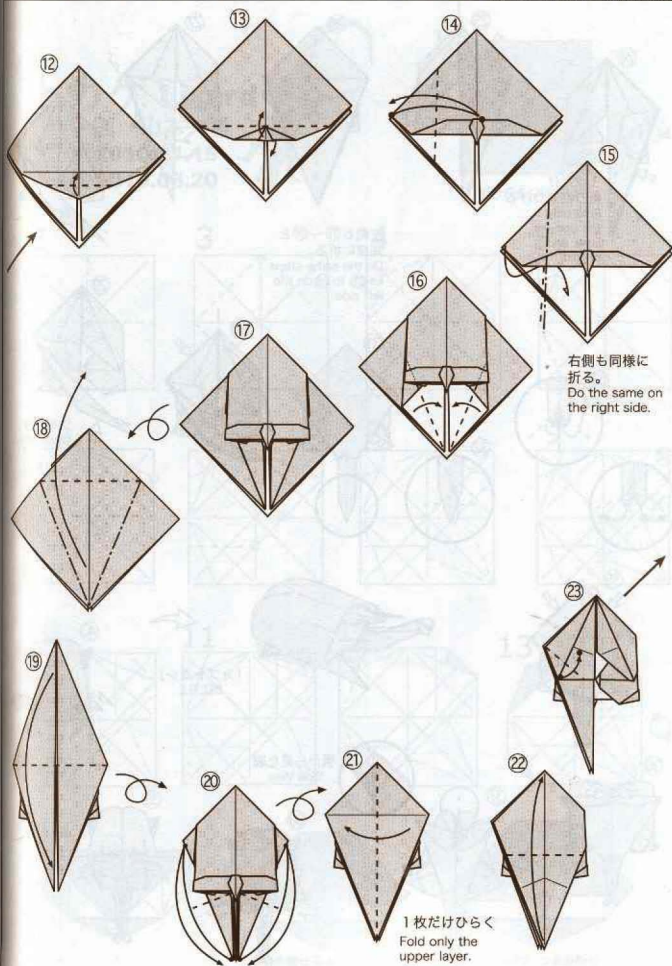

根の  
ack

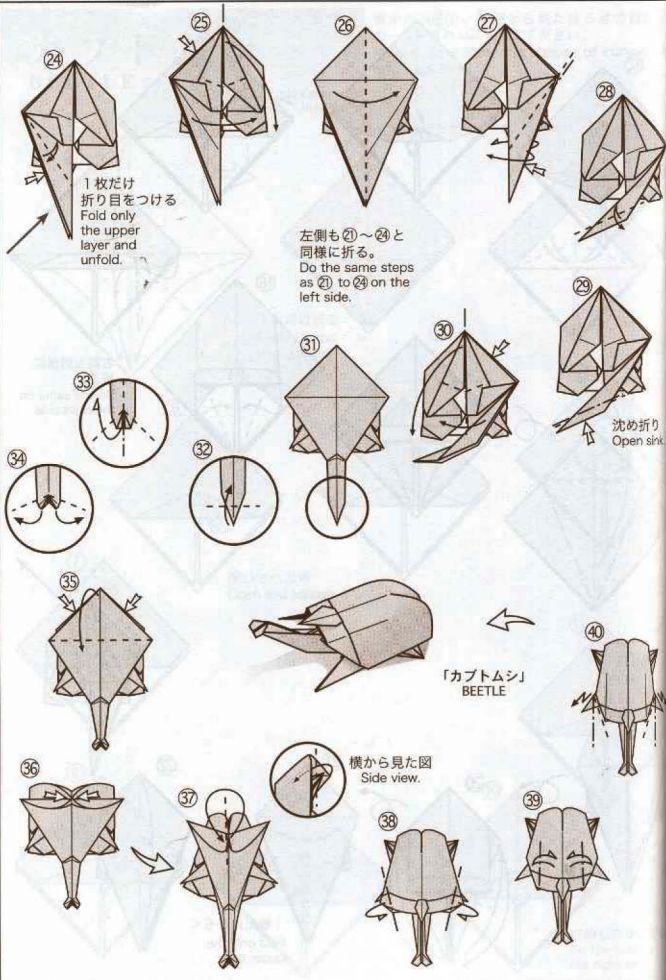

1枚だけ  
折り目をつける  
Fold only  
the upper  
layer and  
unfold.

左側も⑳～㉔と  
同様に折る。  
Do the same steps  
as ㉑ to ㉔ on the  
left side.

沈め折り  
Open sink

横から見た図  
Side view.

「カブトムシ」  
BEETLE



## トカゲ Lizard

作・図 山本大雅

作 2010.01.15

図 2010.06.20



折り筋をつけていく

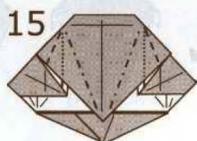
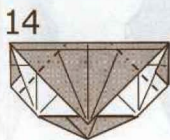
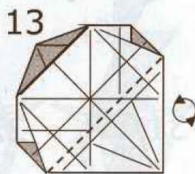
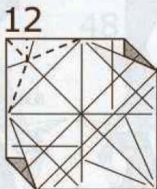
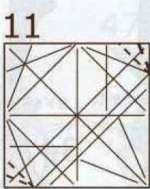
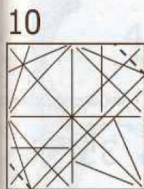
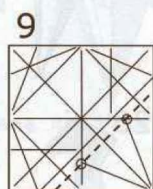
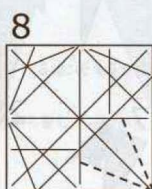
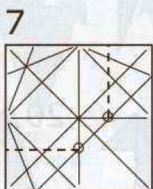
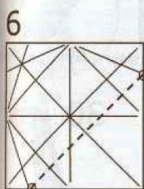
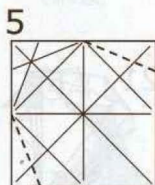
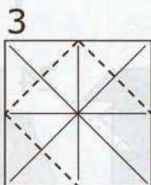
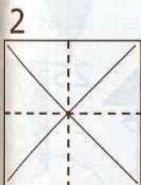

引き寄せるように折る

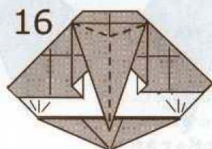

立体的につまみ折り

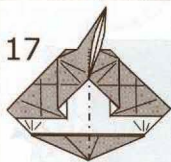

17

後ろへ半分に

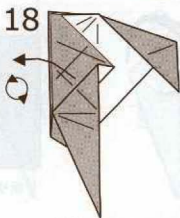

18

立体的に開く

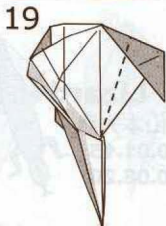

19



20

まとめて中割り折

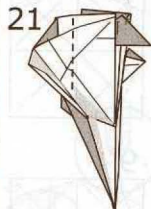

21

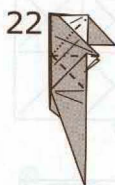

22

引き寄せるように折る

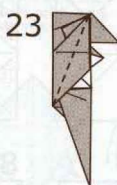

23



24

沈め折り (open sink) 反対も 24 まで折



25

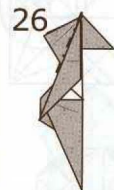

26



27

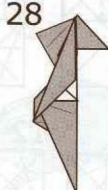

28

反対も 28 まで折る

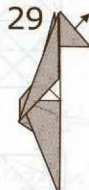

29

カドを引き出す

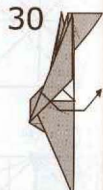

30

中心のヒダで立体的に折

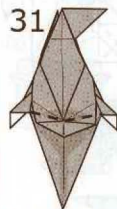

31

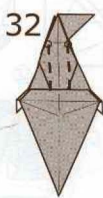

32

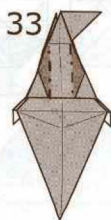

33

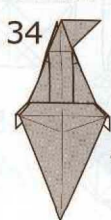

34

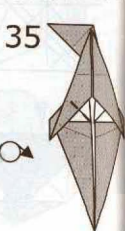

35

起き上がったカドをつぶすように折る

沈め折り (open sink)

36

37 引き寄せ折り

38 戻す

39 折り目を逆にして折り込む

40 戻す

41 1.2の順に折り筋をつける

42 中割り折りしながら畳む

43 カドのところから折る

44 反対も44まで折る

45

46

47 フチに合わせて折り筋をつける

48

49 フチに合わせて折り筋をつける

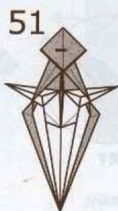
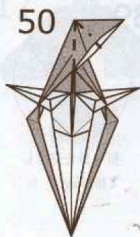

印をつける

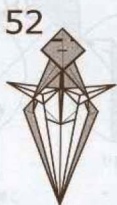

つけた印に合わせて折る



立体的に開く



〇と〇を結ぶ線で折る



ついている線を使っ  
て折り畳む



反対側も 56 まで折る

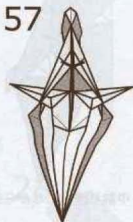

後ろのフチに合わせて折る

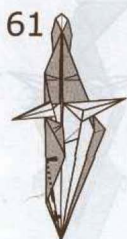
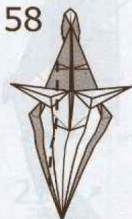

引き寄せ折り

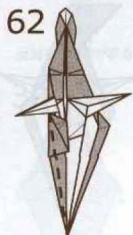

細くするように折る

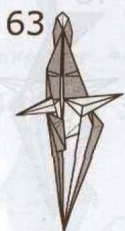

反対側も 63 まで折る





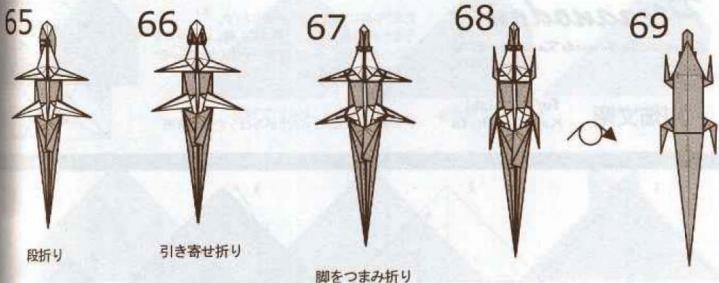

段折り

引き寄せ折り

脚をつまみ折り

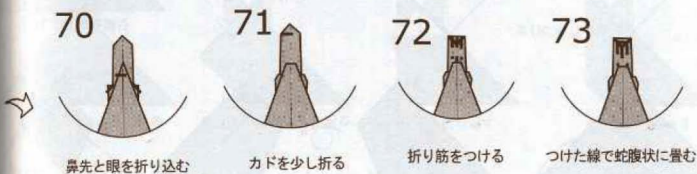

70

鼻先と眼を折り込む

71

カドを少し折る

72

折り筋をつける

73

つけた線で蛇腹状に畳む

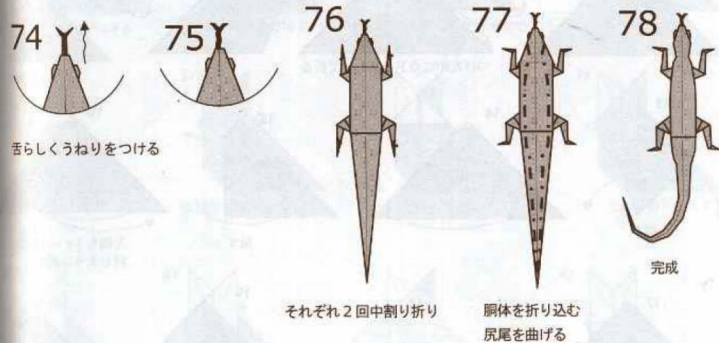

74

舌らしくうねりをつける

75

76

それぞれ2回中割り折り

77

胴体を折り込む  
尻尾を曲げる

78

完成

## Pteranodon

Copyright By Fumiaki Kawahata 2010  
Create 2008

川畑文昭



約20年前に創作したもののリメイク。\*1  
今昔の作品を見ると、ずいぶん難しい折り方をして  
いると思う。すこしは折りやすくなっている  
のではないかなと思う。

\*1「空想おりがみ」(おりがみはうす刊) 参照

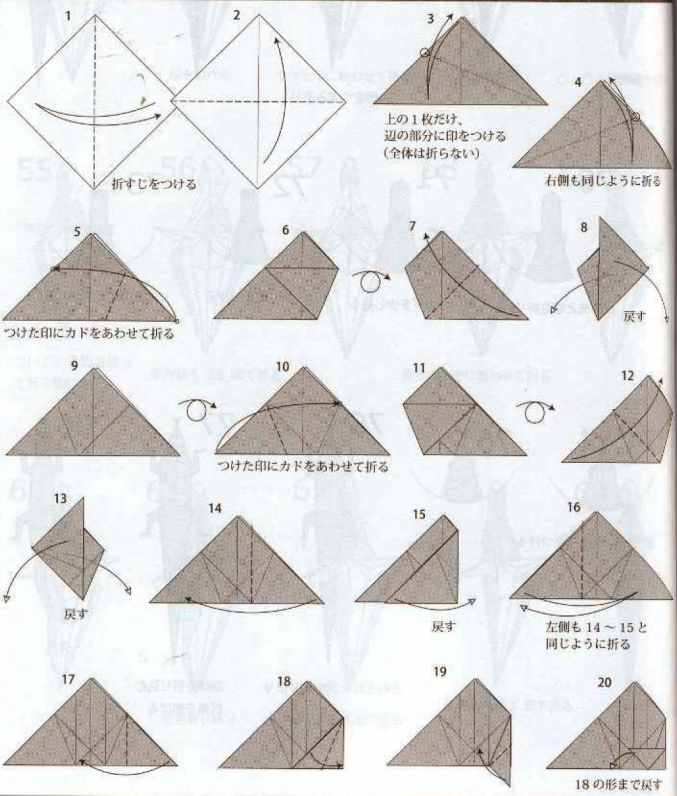
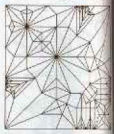

折すじをつける

上の1枚だけ、  
辺の部分に印をつける  
(全体は折らない)

右側も同じように折る

つけた印にカドをあわせて折る

戻す

つけた印にカドをあわせて折る

戻す

戻す

左側も14~15と  
同じように折る

18の形まで戻す

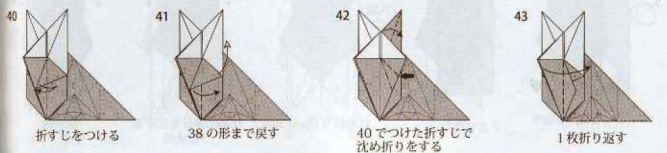
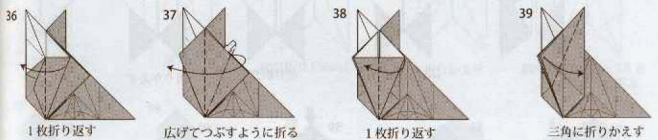
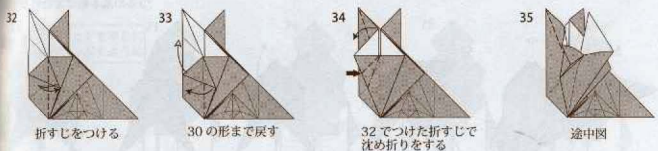
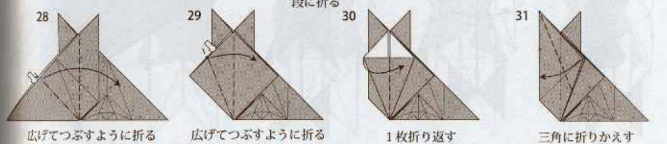
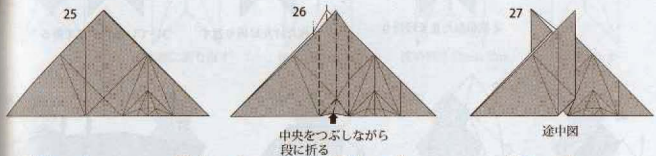
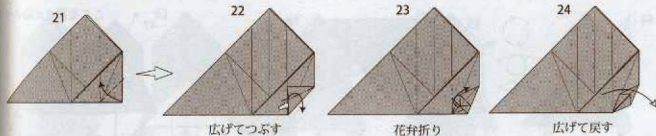

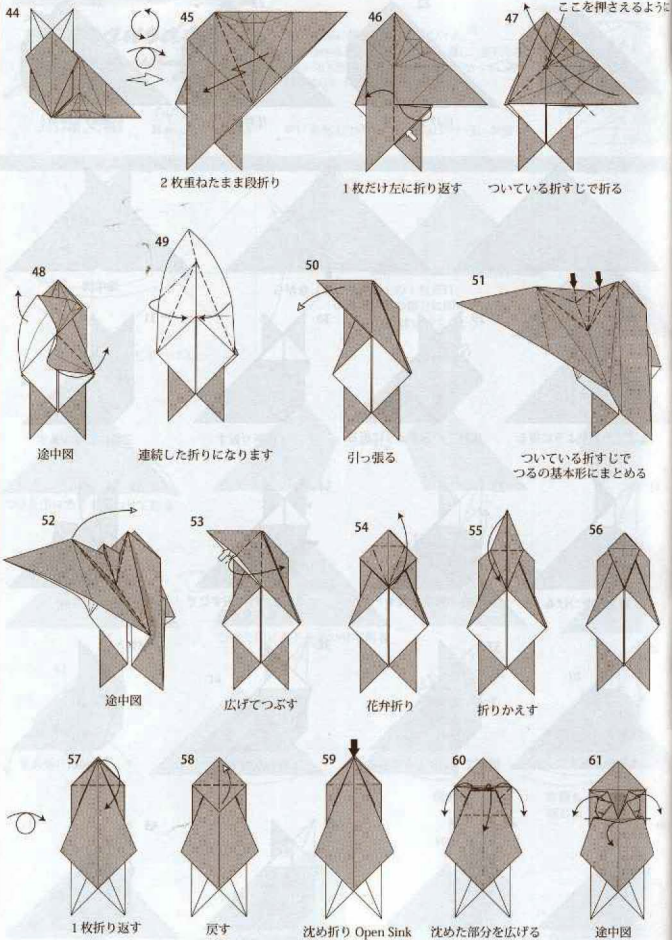



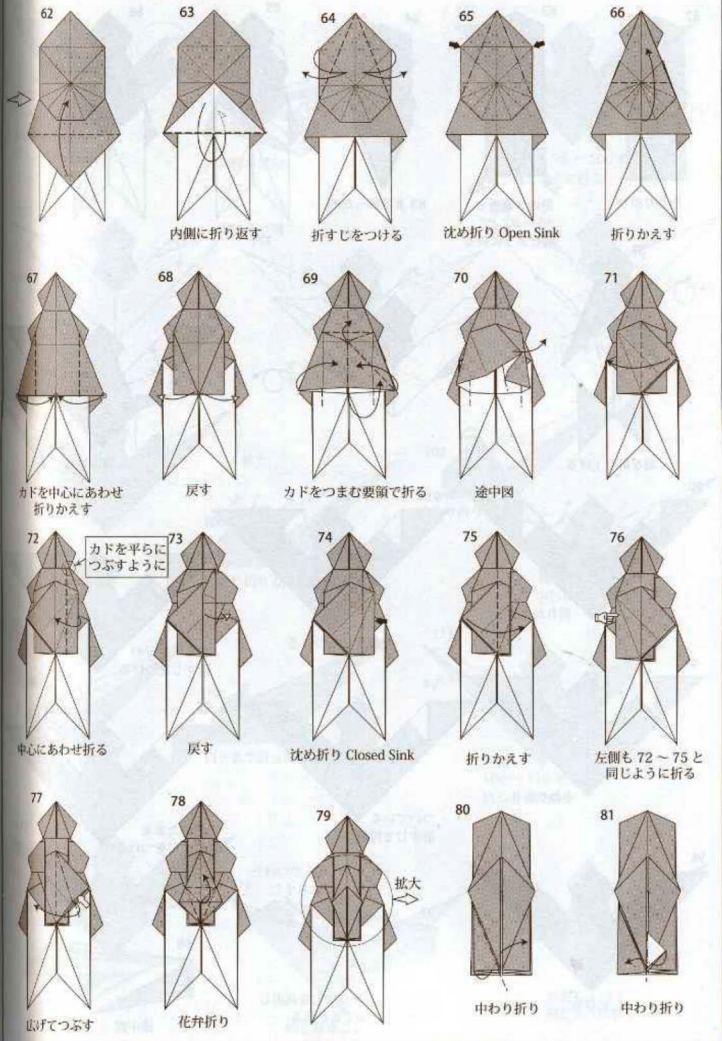



82 中わり折り



83 他の3箇所も  
80~82と  
同じように折る



84 83まで折った形

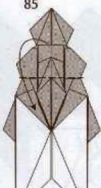

85 折りかえす

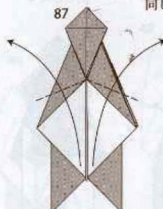
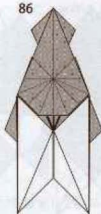

87 羽を折り上げる

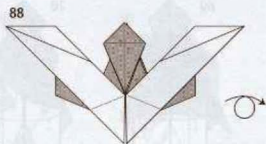

88

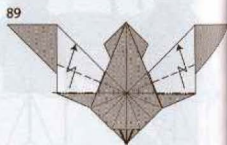

89 段折り

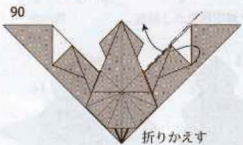

90 折りかえす

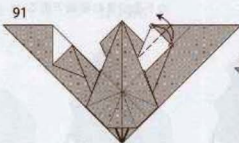

91 折すじをつける

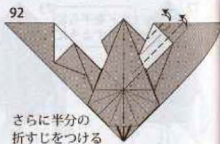

92 さらに半分の  
折すじをつける

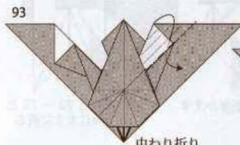

93 中わり折り

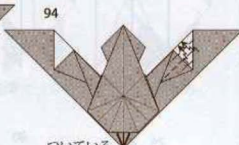

94 ついている  
折すじで段折り

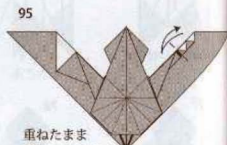

95 重ねたまま  
折すじをつける

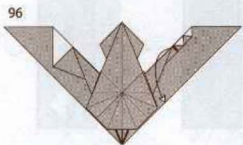

96 広げる

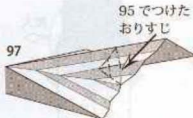

97 95でつけた  
おりすじ  
95でつけたおりすじを利用し  
蛇腹折の要領でまとめる



98 途中図

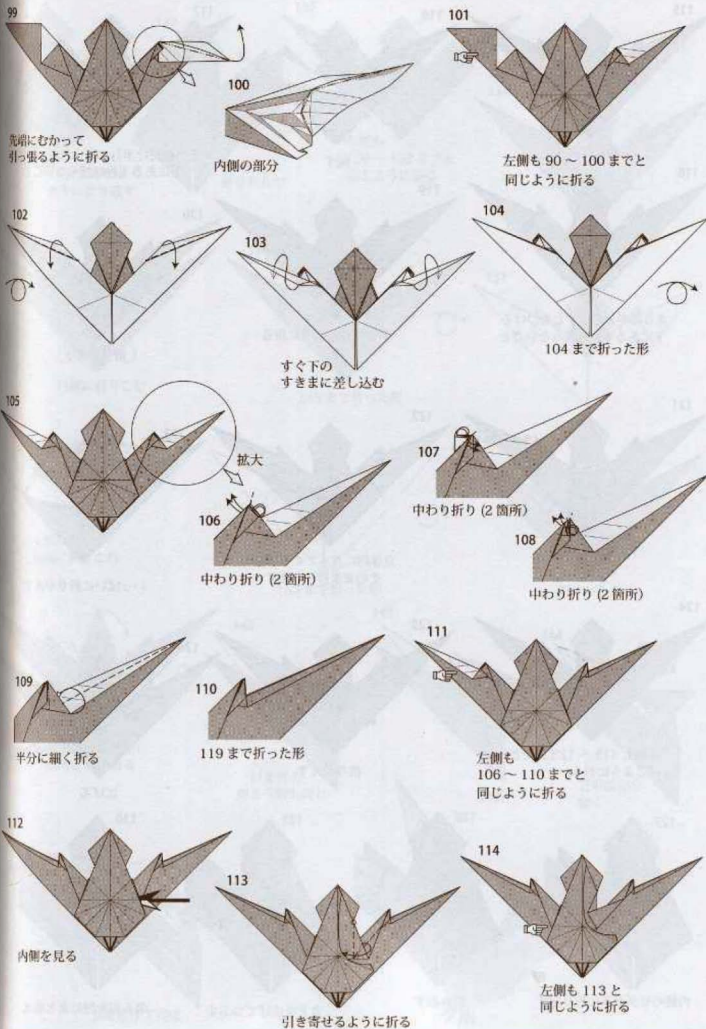

99  
 先端に向かって  
 引っ張るように折る

100  
 内側の部分

101  
 左側も90~100までと  
 同じように折る

102

103  
 すぐ下の  
 すきまに差し込む

104  
 104まで折った形

105  
 拡大  
 106  
 中わり折り(2箇所)

107  
 中わり折り(2箇所)  
 108  
 中わり折り(2箇所)

109  
 半分に細く折る

110  
 119まで折った形

111  
 左側も  
 106~110までと  
 同じように折る

112  
 内側を見る

113  
 引き寄せるように折る

114  
 左側も113と  
 同じように折る

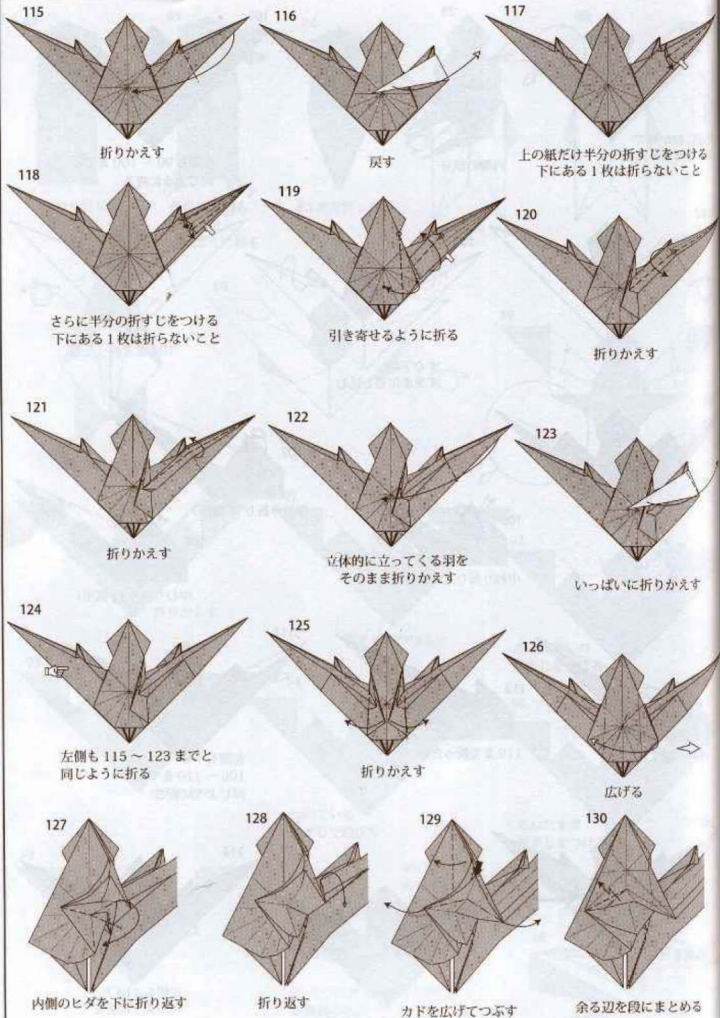



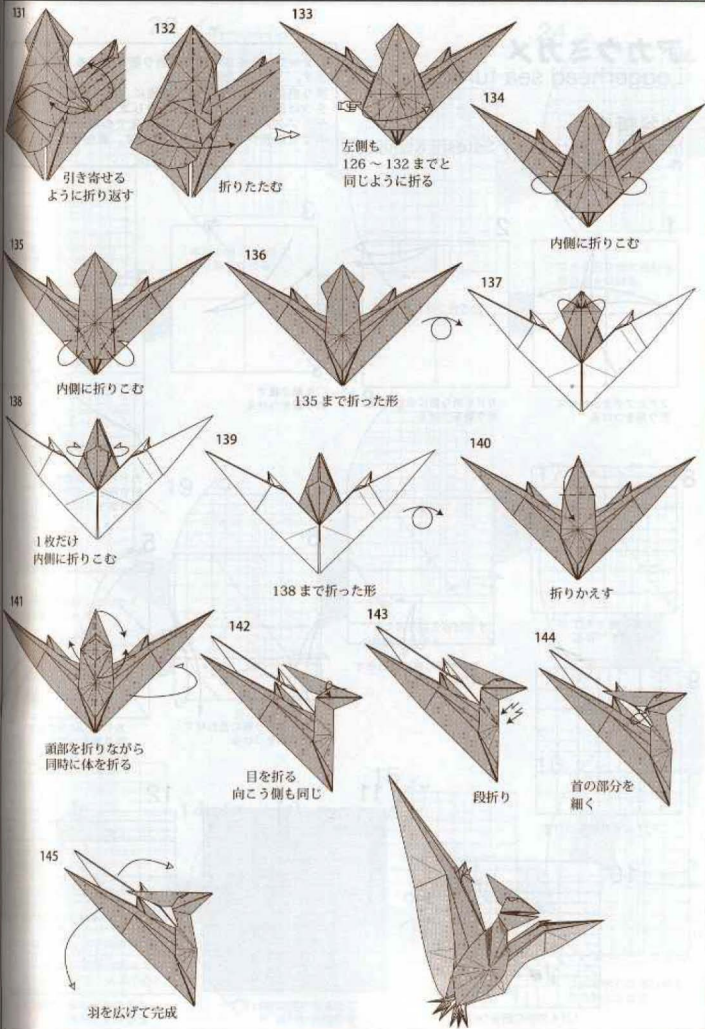

## アカウミガメ Loggerhead sea turtle

神谷哲史  
Model & Diagrams by Satoshi Kamiya  
作 2002/05/21

ステップ 40 くらいまで、折り筋をつける工程が続きます。

折り筋は一本ずつ丁寧に正確に、また絶対に折り筋をつけ間違わないように注意しましょう。特に、ステップ 29 の繰り返しは、これまでの神谷の折り図の中でも最悪クラスの繰り返しです。覚悟して下さい。

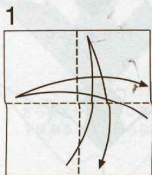

フチとフチを合わせて折り筋をつける

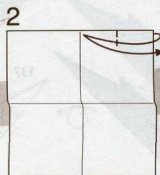

カドを折り筋に合わせて折り筋をつける

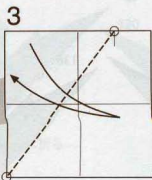

○を結ぶ線で折り筋をつける

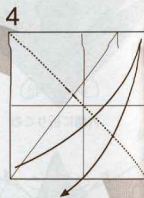

カドとカドを合わせて折り筋との交点に折り筋をつける

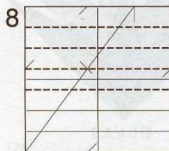

同様の幅で1/7の折り筋をつける

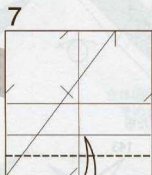

フチを折り筋に合わせて折り筋をつける

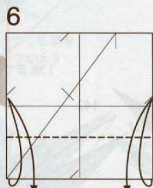

カドを折り筋に合わせて折り筋をつける

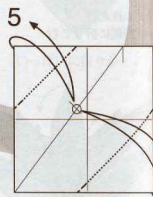

カドを○に合わせて折り筋をつける



1/7の折り筋をつける



1/14の折り筋をつける

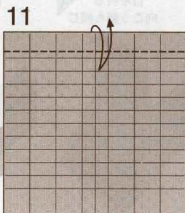

フチを折り筋に合わせて折り筋をつける



さらに半分の幅 (3/56) で折り筋をつける

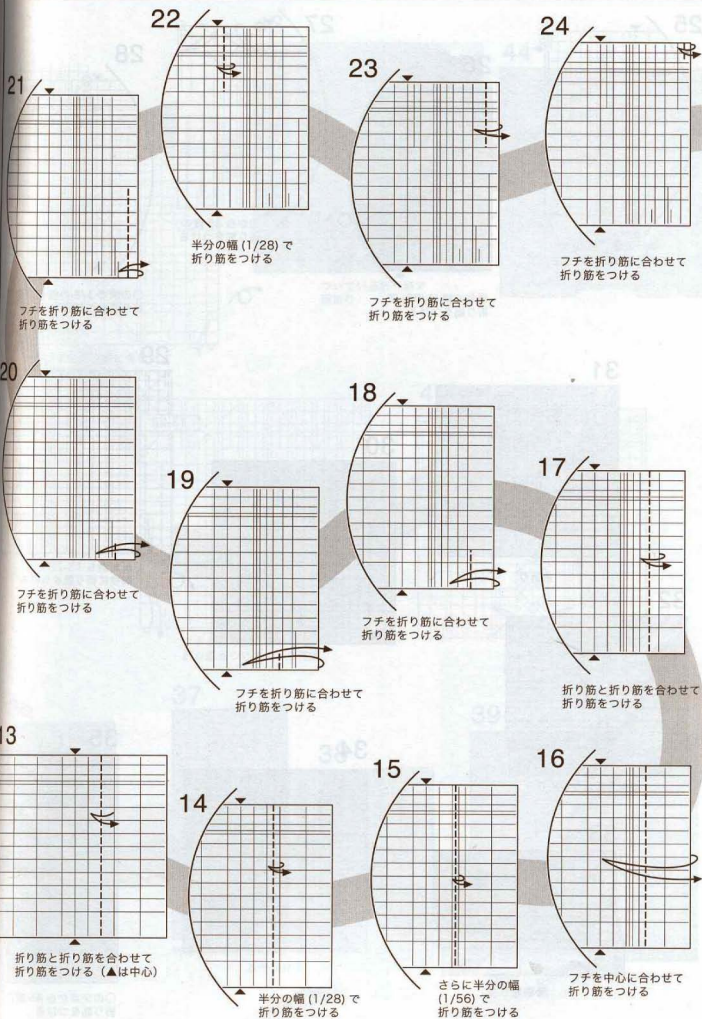



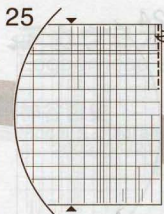

25 半分の幅 (1/56) で  
折り筋をつける

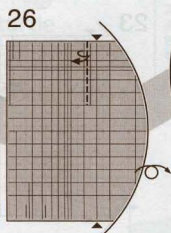

26 半分の幅 (1/56) で  
折り筋をつける

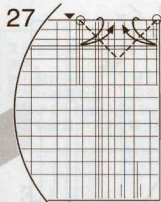

27 ○から 45 度の  
折り筋をつける

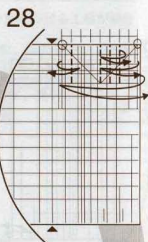

28 ○の間の 1/8 の幅 (3/56) で  
折り筋をつける

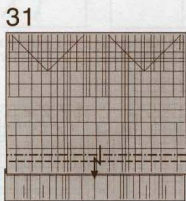

31 段折り

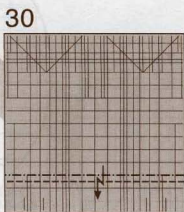

30 段折り



29 反対側も 13-28 と  
同様に折り筋をつける

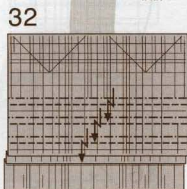

32 段折り段折り段折り

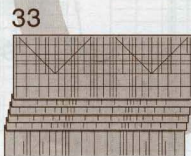

33 戻す

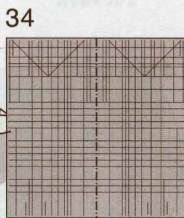

34 半分に折る



35 ○の交点から 45 度の  
折り筋をつける



42

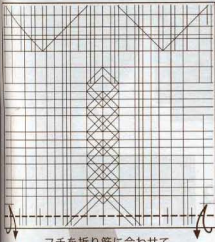

フチを折り筋に合わせて  
折り筋をつける

43

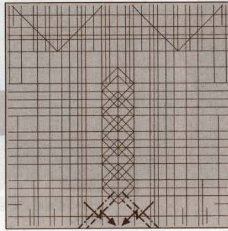

ついている折り筋で  
段折り

44

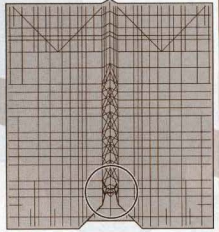

ついている折り筋で  
段折り

41

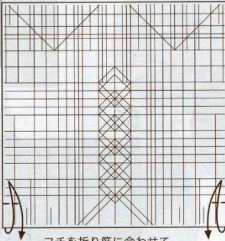

フチを折り筋に合わせて  
折り筋をつける

40

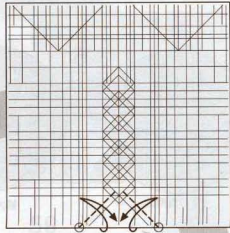

○から45度の  
折り筋をつける

36



○の交点から45度の  
折り筋をつける

37

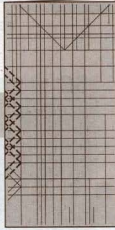

同様に折り筋をつける

38



戻す

39

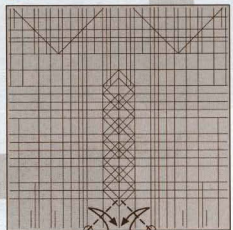

ついている折り筋を伸ばすようにして  
折り筋をつける

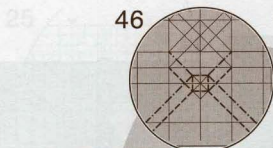

46の展開図

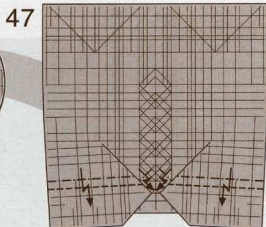

47の展開図

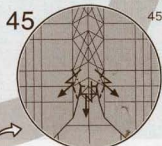
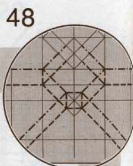

ついている折り筋を使って  
つぶすように折って  
ひだの向きを変える

ヒダの向きを変えるように  
段折り

49

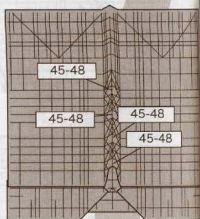

残りの箇所も 45-48 と  
同じように折る

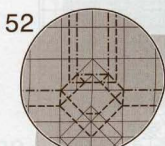

52の展開図

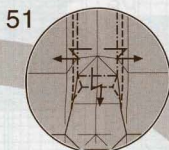

拡大図

50

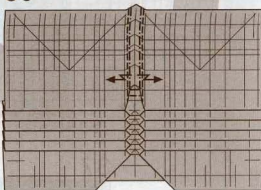

平らに折り畳む

53

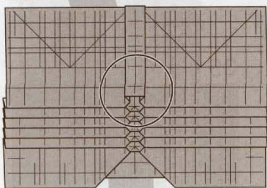

54



内側の部分を  
後ろから  
押し出すように  
しずめ折り (Unsink)

55

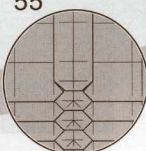

56

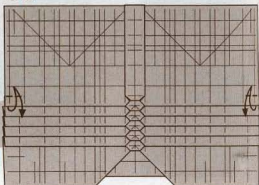

フチを折り筋に合わせて  
折り筋をつける

65

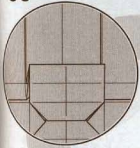

66

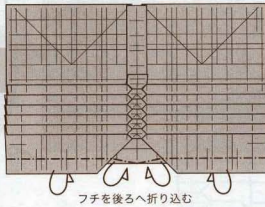

フチを後ろへ折り込む

67

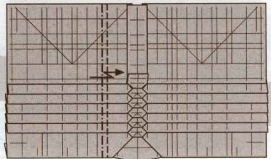

段折り

64

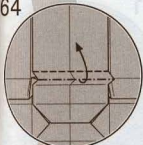

平らに折り畳む

61

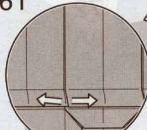

ヒダを広げる

60

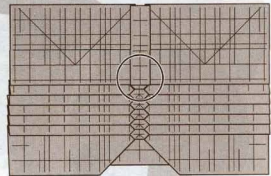

63

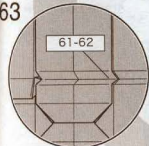

反対側も 61-62 と  
同様に折る

62

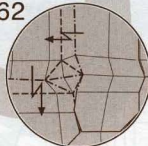

ヒダを引き出して  
反対側に折り畳む

59

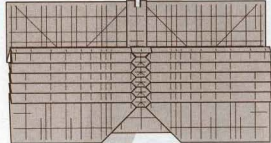

ヒダを広げる

57

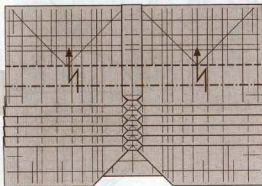

段折り

58

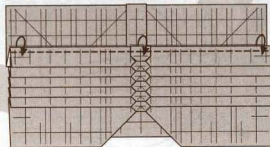

フチを折り筋に  
合わせて折る



68

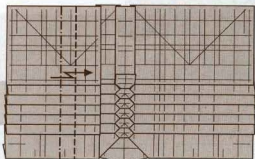

段折り

69

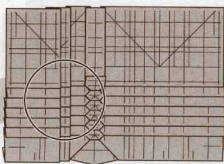

70

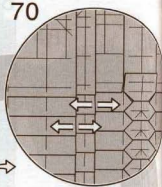

ヒダを軽く開く

73

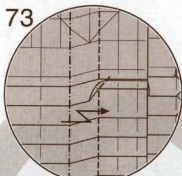

平らに折り畳む

72

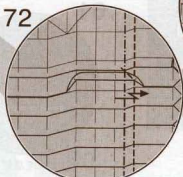

平らに折り畳む

71

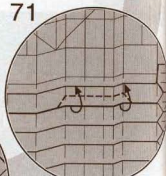

フチとフチを合わせて  
引き寄せるように折る

74

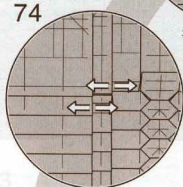

ヒダを軽く開いて  
折ったフチを戻す

77

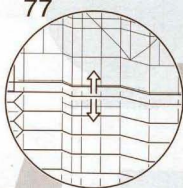

ヒダを広げる

78

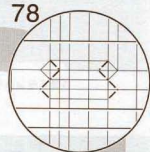

図のように折り筋をつける

75

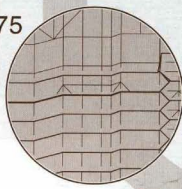

76

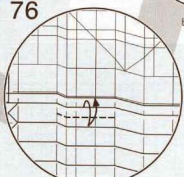

フチとフチを合わせて  
折り筋をつける

79

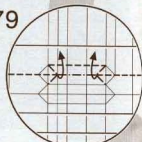

つけた折り筋を使って  
ヒダを作るように  
押し出す





半マスずらして  
80と同じように  
折り畳む

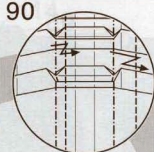

平らに折り畳む

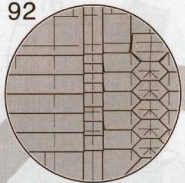
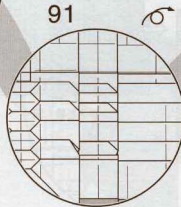

反対側も 67-91 と  
同様に折る

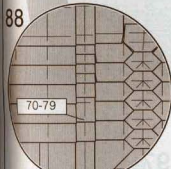

次のヒダも 70-79 までと  
同様に折る

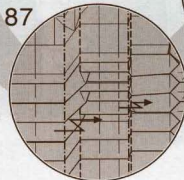

平らに折り畳む

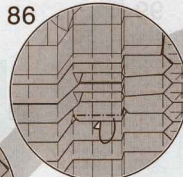

フチを後ろへ折り込む

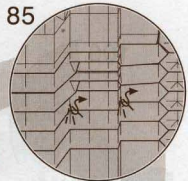

中割り折り

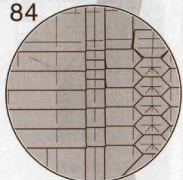

ヒダを軽く開く

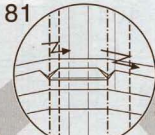

平らに折り畳む

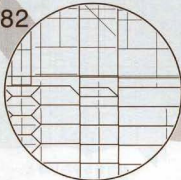

ついている折り筋を使って  
中心と左右にヒダを  
作るように折る

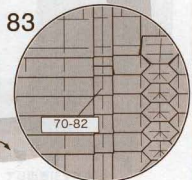

次のヒダも 70-82 と  
同様に折る

93

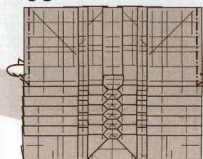

ついている折り跡で  
フチを後ろへ折り込む

94

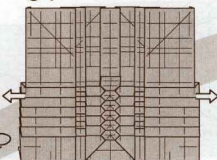

ヒダを軽く開く

95

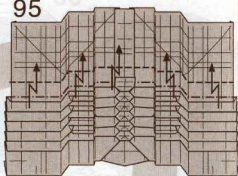

段折り

96

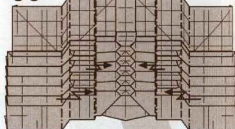

平らに折り畳む

100



同じようにして  
ヒダを合わせて  
ずらすように  
段折りで折り畳む

99



引き寄せるように  
段折りで折り畳む

98



フチを後ろへ折り込む

97

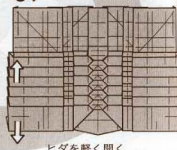

ヒダを軽く開く

101

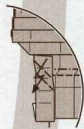

平らに折り畳む

102

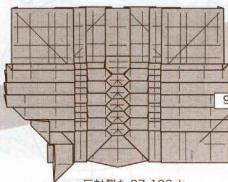

反対側も 97-103 と  
同様に折る

97-103

フチを後ろへ折る

103

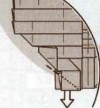

カドを引き出して  
つまむように折る

104

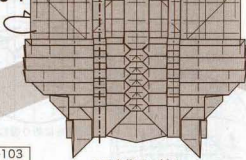

113

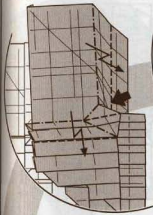

そのまま上の部分を  
3/5の幅の蛇腹状になるように  
折り畳む

114

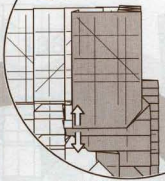

ヒダを軽く開く

116

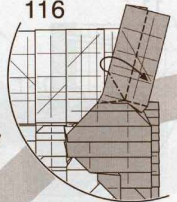

フチとフチを合わせて  
平らに折り畳む

115

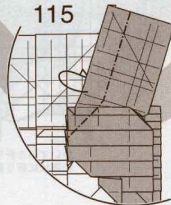

フチを後ろへ折る

112

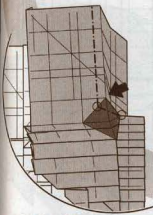

○を結ぶ線で  
つまむように折り筋をつける

111



109でつけた折り筋の部分  
平らにする

110

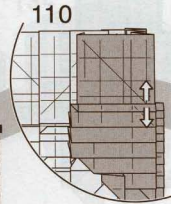

ヒダを広げる

109



斜めに折り筋をつける

106

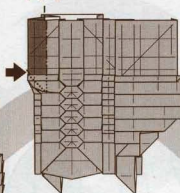

フチを押し込むように  
しずめ折り

105

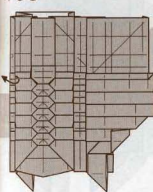

フチを軽く広げる

107

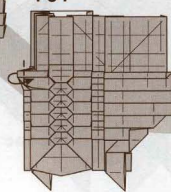

フチを戻す

108

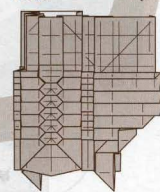

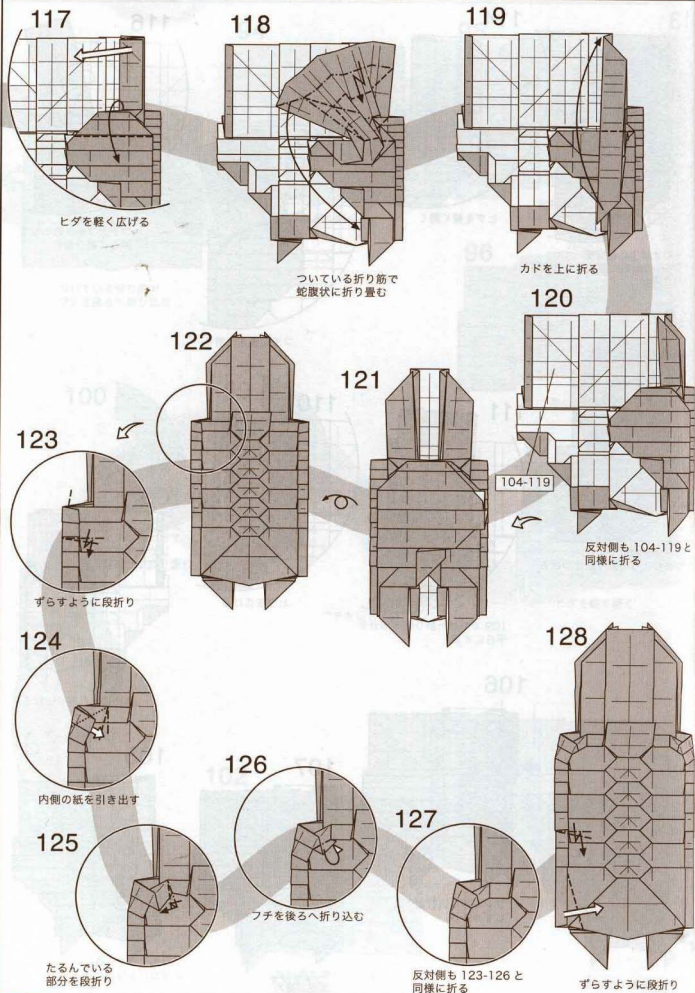



137

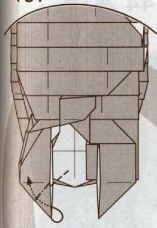

カドを内側へ  
折り込むように中割り折り

138

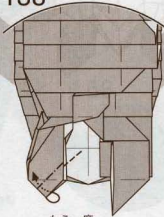

もう一度  
中割り折り

139

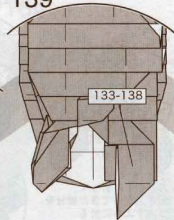

反対側も 133-138 と  
同様に折る

140

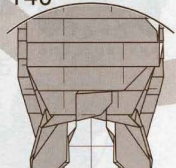

内側の部分を透視

136

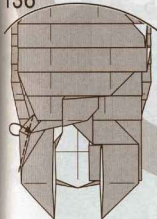

カドを隙間へ折り込む

135

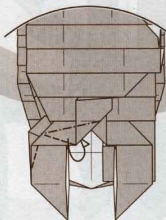

カドを後ろへ折り込む

134

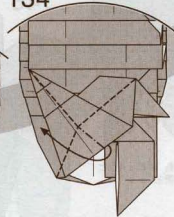

カドを引き寄せて  
つまむように折る

133

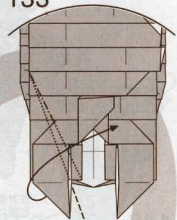

中割り折りのように  
折って広げる

130

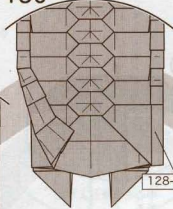

反対側も 128-129 と  
同様に折る

129

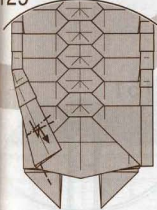

ずらすように段折り

131

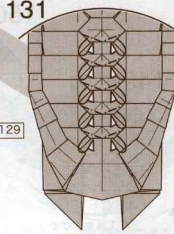

カドを後ろへ折り込む

132

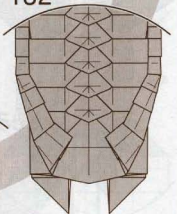

141

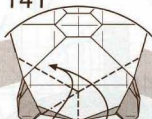

カドをつまむように折る

142

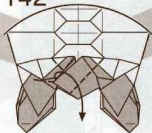

カドを下に折って  
起き上がった部分を  
つぶすように折る

143

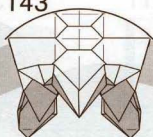

144

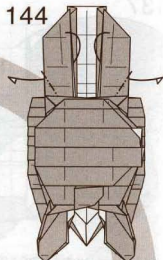

カドを斜めに折る

147

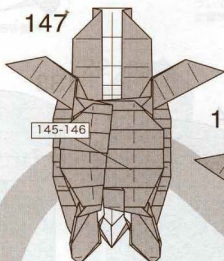

145-146

反対側も 145-146 と  
同様に折る

146

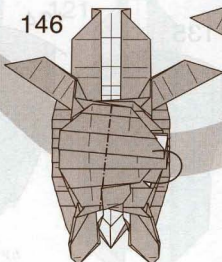

斜めに内側へ折り込む

145

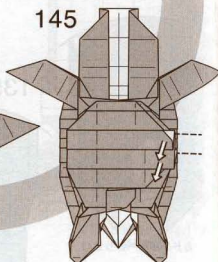

ヒダをずらすように折る

148

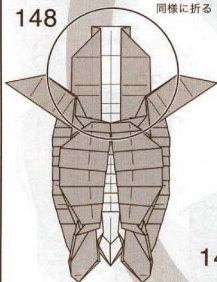

150

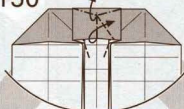

中心をつまむように  
折る

149

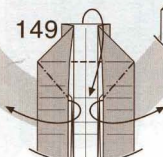

上の1枚を広げて  
つぶすように折る

151

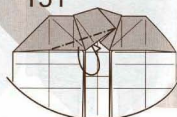

カドを内側へ折り込む

Japão Burajirujin  
www.japoburajirujin.blogspot.com

162

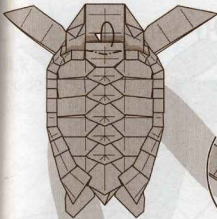

フチを内側に折り込む



161



ヒダをずらして  
形を調整する

160

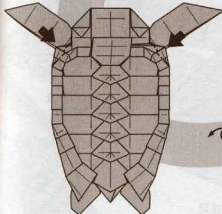

甲羅を立体的にする

163



首を細くするように  
折りながら段折り

164

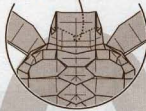

後ろのカドを引き出す

165

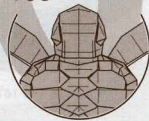

166



カドをつまむように折る

158



157



カドを後ろへ折る

159

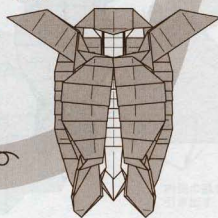

156

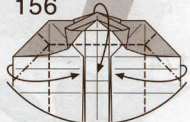

それぞれフチを折って  
カドの部分をつまむように折る

152

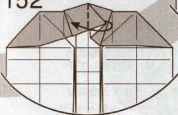

カドを反対側に折る

153

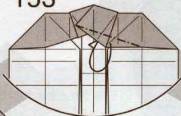

カドを内側へ折り込む

154

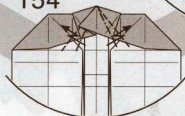

中心線を合わせて  
両側で段折り

155



カドを上へ折る

アカウミガメ / 神谷哲史 (東京都)

167



内側のカドを下へ折る

168

166-167



反対側も 166-167 と同様に折る

169



170

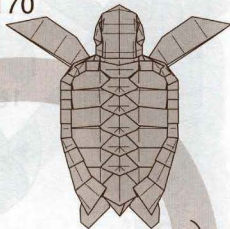

173

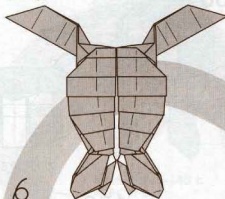

172

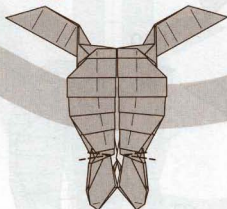

段折り

171

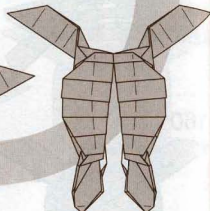

腹の甲羅のフチを適当に合わせる

174

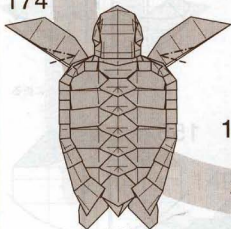

段折り

175

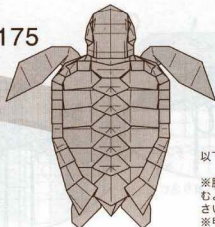

完成

以下好きなように仕上げる。

※腹の部分は、折り込んだ部分を巻き込むように折って留めたり、糊付けして下さい。

※甲羅のぐらゐり折りは、立体化と合わせて調整します。



# クローントルーパー (ヘルメット)

## Clone Trooper (Helmet)

森末 圭

model:2009/7/20 diagram:2010/6/15

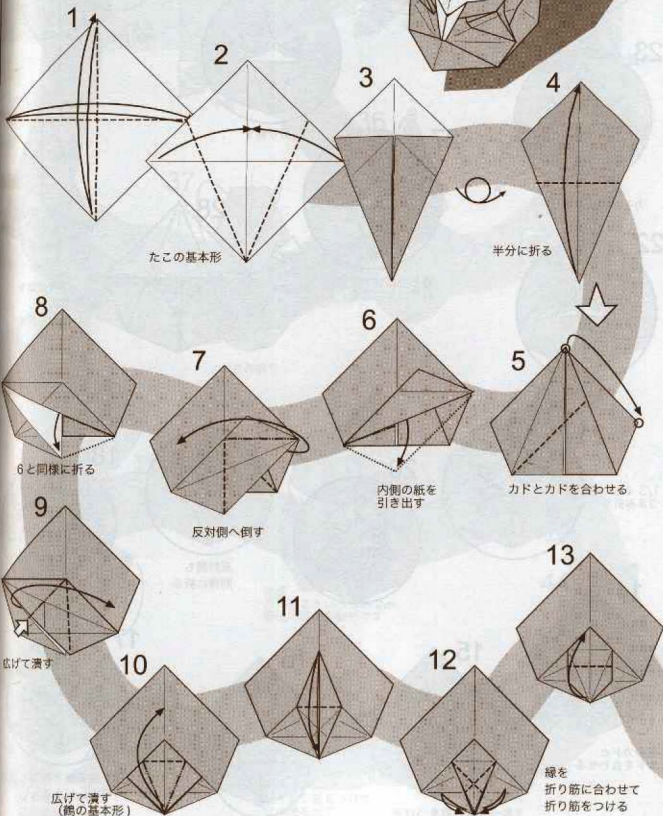
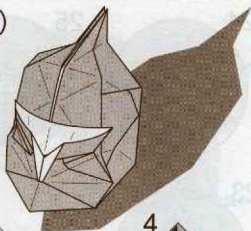

クローントルーパー (ヘルメット) / 森末 圭 (東京都)

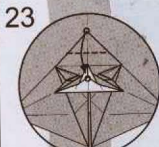
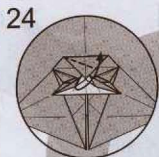

カドと印を合わせる

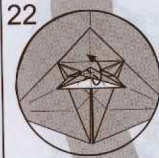

つまみ折り



1/3 くらいを  
つまみ折り

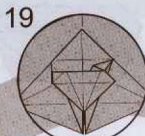

反対側も  
同様に折る



中割り折り

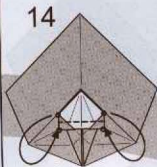

印のカドと  
カドを合わせる

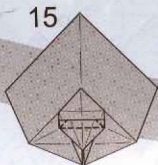

折り筋をつける

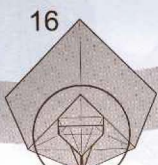

印を通る筋で仲割り折り  
(平らにはならない)

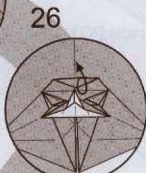
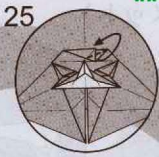

折り倒す



縁を合わせて垂直に  
折り筋をつける

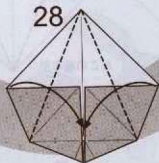

大きく  
半分に折る



後ろの紙を  
前に出し  
ながら折る

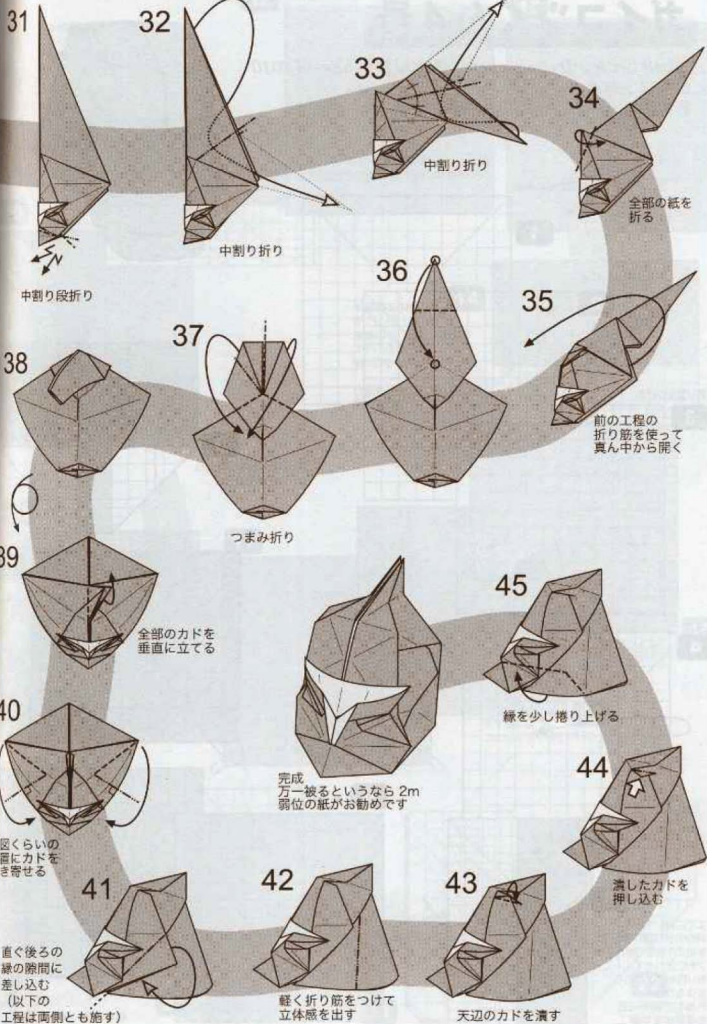



# ガイコツくん4号

"Skull (with 3-D eye sockets)" ©HOJYO Takashi 2010

創作・図: 北條高史

創作2010/02/21 作図2010/06/20

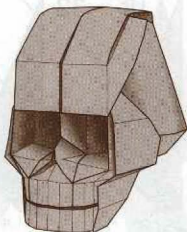

12等分の記線から始める  
両面の色が同じ紙を使用する  
図では理解の便のため表裏を色分けしてある

折り目をつける

1

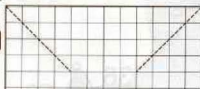

折り目をつける

2



折り目をつける

3

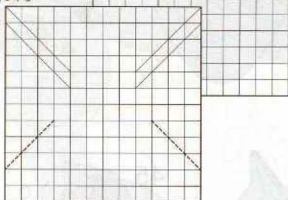

4

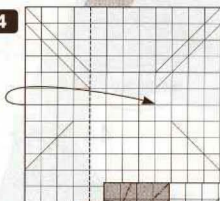

5

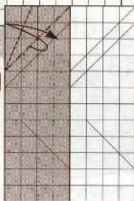

すでに付いている斜めの折り目の部分で手前の1枚をつまんでフチに合わせて折り目をつけたのち全体をひらく  
右側も工程4~5と同様に加工する

6

折り目をつける

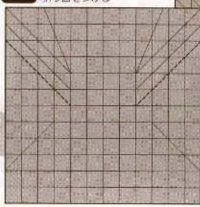

9

折り目をついたら全体をひらく

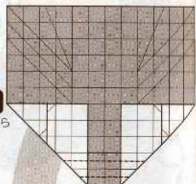

8

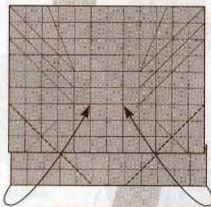

7

幅を半分にするように身折り



**12** 折り目をつける

手前側の1枚のみ  
すでに付いている  
垂直の折り目をつまんで  
フチに合わせて折り目をつける

左側も同様に加工したのち  
全体をひらく

**11****10****13****14**

手前側の1枚のみ  
すでに付いている  
垂直の折り目をつまんで  
フチに合わせて  
折り目をつける

右側も同様に加工したのち  
全体をひらく

**18****17****15**

点を結ぶように  
つまんで折り目をつける

**16**

点を結ぶように  
つまんで折り目をつける

**19**

フチの部分に少しだけ  
折り目をつける

**20**

点を結ぶように  
つまんで折り目をつける

**21****22**

折り目をつけたのち  
工程21まで戻す

8

7

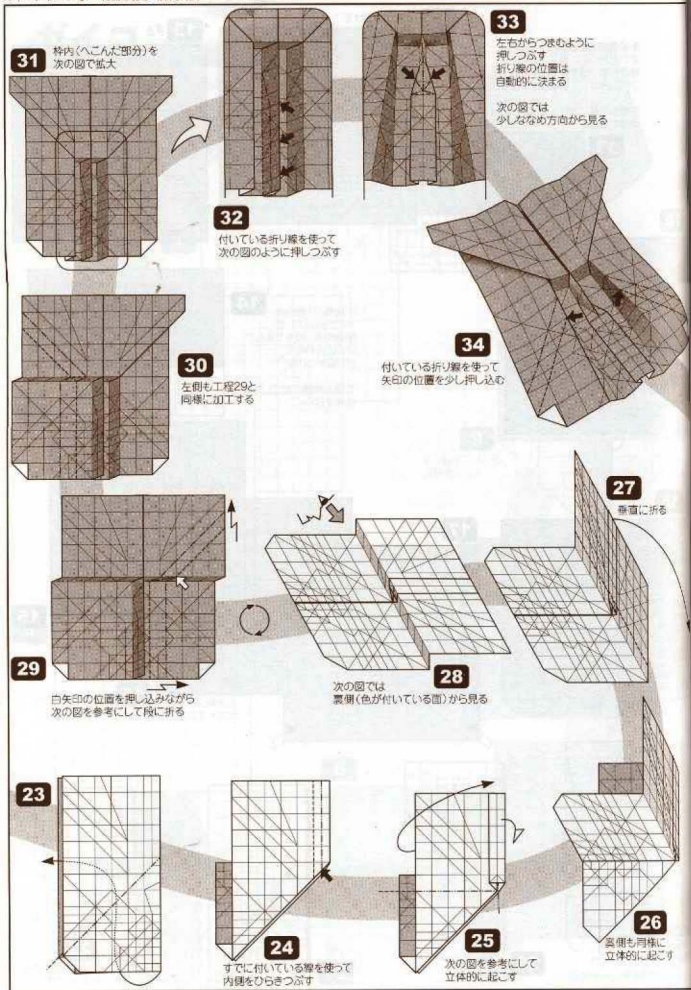

**31** 枠内(へこんだ部分)を次の図で拡大

**33** 左右からつまむように押しつぶす  
折り線の位置は自動的に決まる  
次の図では少しなめ方向から見る

**32** 付いている折り線を使って次の図のように押しつぶす

**30** 左側も工程29と同様に加工する

**34** 付いている折り線を使って矢印の位置を少し押し込む

**29** 白矢印の位置を押し込みながら次の図を参考にして段に折る

**28** 次の図では裏側(色が付いている面)から見る

**27** 裏面に折る

**23**

**24** すでに付いている線を使って内側をひらきつづす

**25** 次の図を参考にして立体的に起こす

**26** 裏側も同様立体的に起こす

工程33~34の加工を復活させながら  
全体を中央に寄せ集める

35

折り内側に押し込み  
工程33の加工が一部戻ってしまいが  
次の工程で全体を直すので  
多少戻しなくても良い

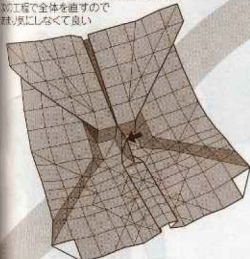

36

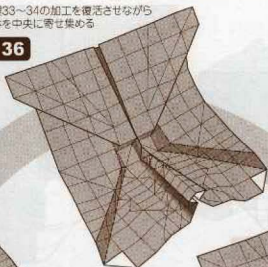

矢印の起点部分を  
左右に引いて広げながら  
谷折り線の部分を  
少し押し込む

次の図を参考にして  
縫穴のような形に決める

37

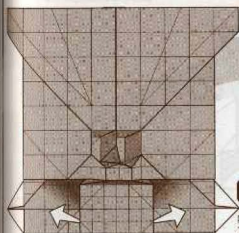
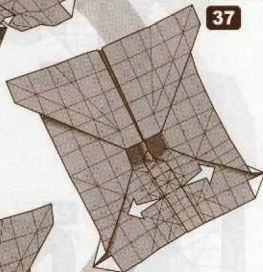

39

内側の紙を引き出して  
次の図のような形にする



38

段折りを連続させながら  
まとめる

41

次の図で  
枠内を拡大

次の図のように  
押しあわせる

40

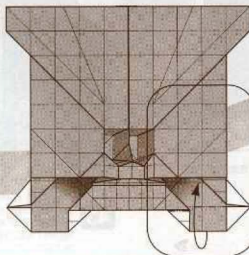
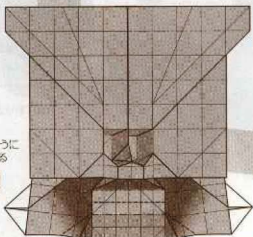

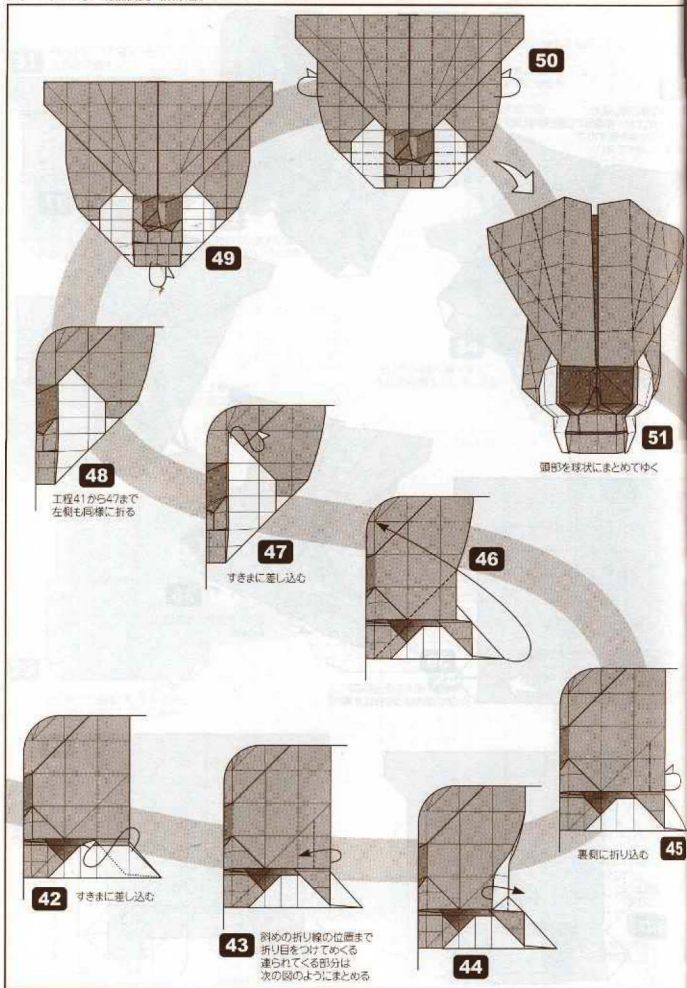



前面の山折り線は  
工程52の折り線の交点を結んで  
つまむようにして付ける

53



54

裏側へ折り込む



52

折り線どうしを合わせて  
角度を半分にするように折る



55

鼻骨の先端を  
沈め込む

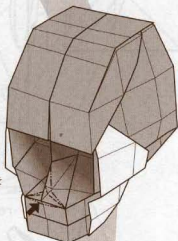

56

すでに付いている線を延長して  
つまんで折り目をつける

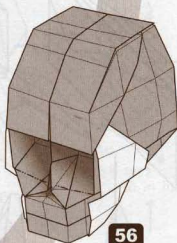

58

完成

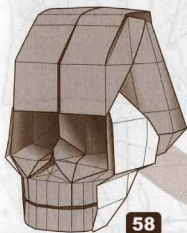

57

半分の幅につまんで  
歯の折り目をつける

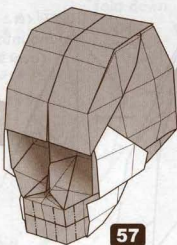

45

## 人の形 Human Figure

藤倉 敦夫 Atsuo Fujikura

紙裏から見る Back side

1 折り筋をつける crease

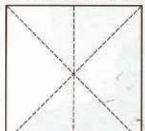

2 折りポイントを出します point for fold

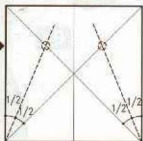

3 山折りと谷折りで折り筋をつけます crease  
4 裏返して折り線の通りに畳みます pattern at fold

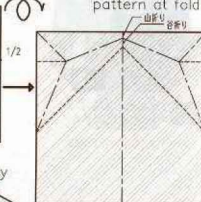
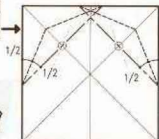

7 中割り折り reverse fold

8 少し拡大表示

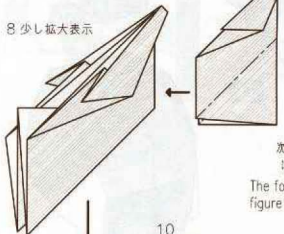

6 途中の図 way

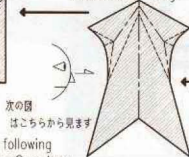

次の図はこちらから見ます  
The following figure sees here

5 途中の図 way



10

11 山折り (向こう側も同じ) mountain fold (over there)

12

9

沈め折り open Sink

谷折りで折りあげます valley fold

中割り折り reverse fold



## 26 完成 complete

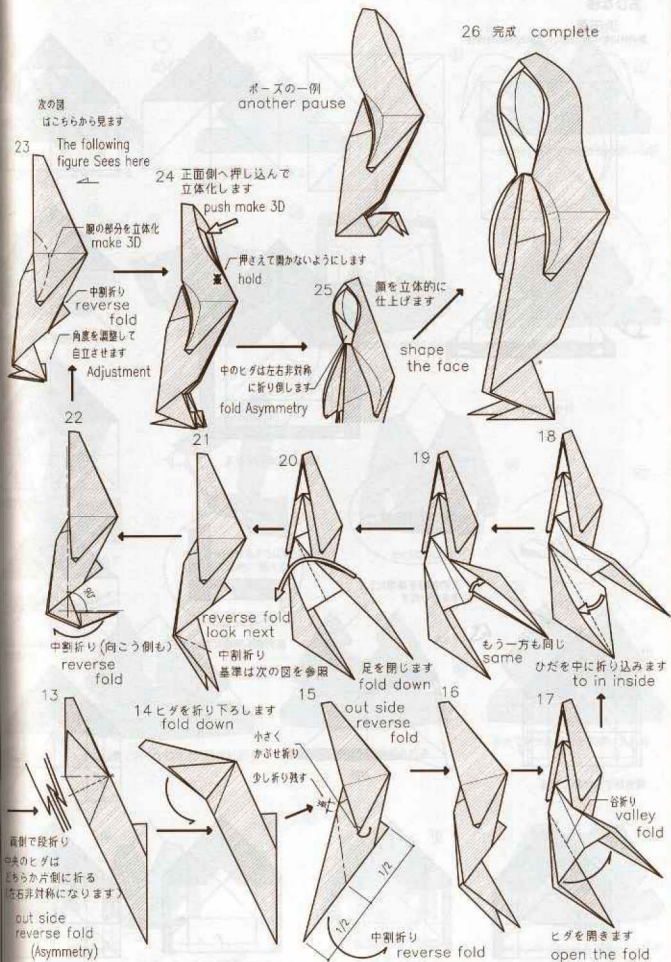

おひな様 / 浜田 勇 (長崎県)

## おひな様

浜田勇  
創作H18年01月05日 作図H22年05月18日

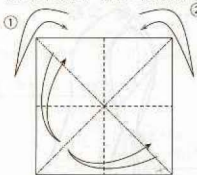

折って戻す

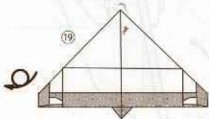

ひっくり返す

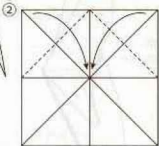

谷折

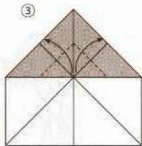

谷折

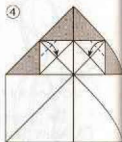

谷折

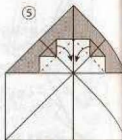

谷折

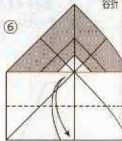

折って戻す

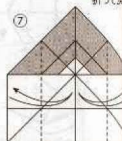

折って戻す

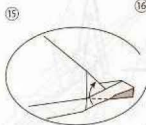

谷折



⑧の折線を基準にして  
手を折りだす

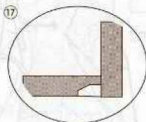

反対側も同様に折る

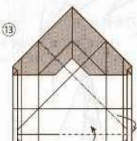

複合折で立体的に折る

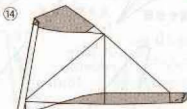

谷折

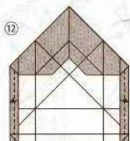

谷折

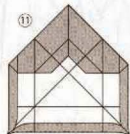

⑩まで戻す

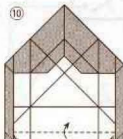

左右の端を注意して立体的に折る

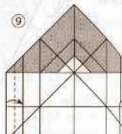

谷折

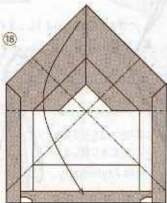

風船の基本形に折る



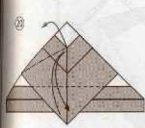

折って戻し、立体的に折る

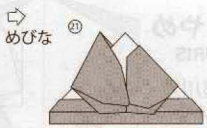

めびな

反対側も折る

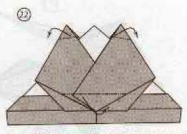

裏側についている折目に従い山折

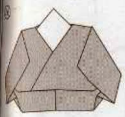

内の内側を拡大して見る、



途中図

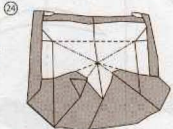

折目に従い本体をくるむように折る

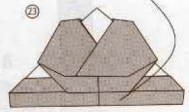

裏側の部分を開く

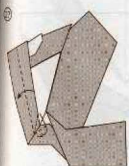

立体的に複合折

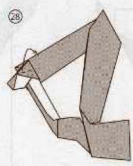

手首を細くなるように折り26の状態西立体的に整える



めびな出来上がり

おびな

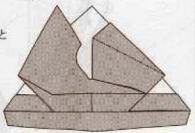

⑥まではめびなと同じ折り

下側は⑥で折った線まで立体的に折る

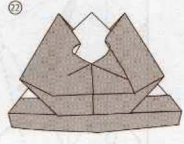

反対側も同様に折り前袋を作る

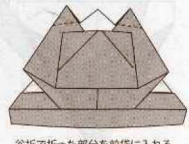

谷折で折った部分を前袋に入れる

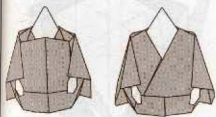

出来上がり

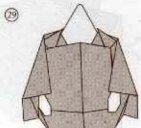

おびな出来上がり

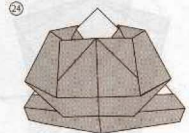

めびなの ②④ からと同じように折る

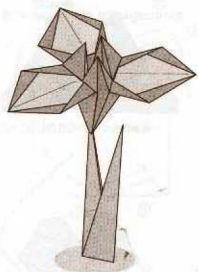

**あやめ**  
**IRIS**  
前川 淳  
2010 MAEKAWA

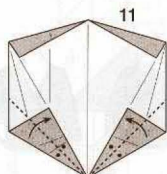
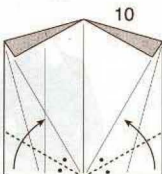
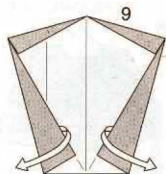
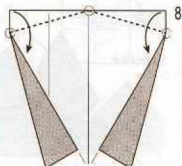
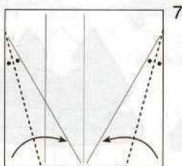
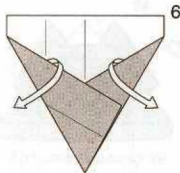
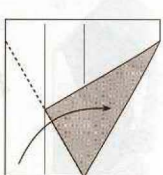
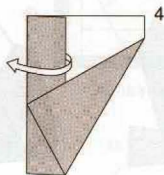
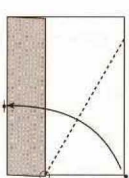
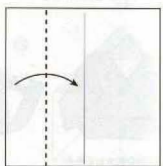
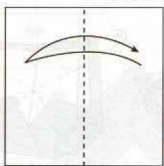
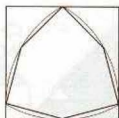

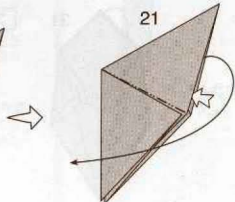
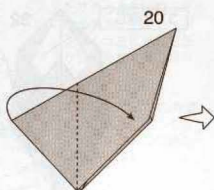
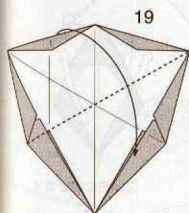
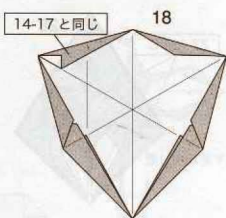
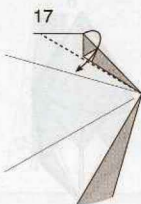
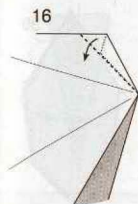
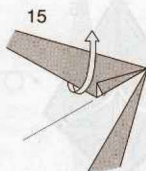
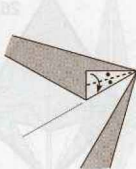
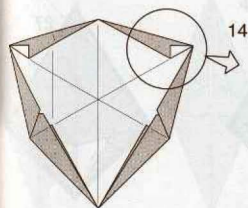
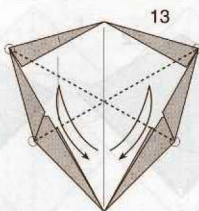
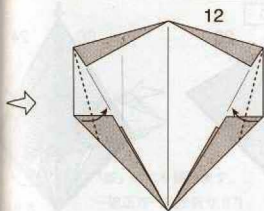

あやめ/前川 淳 (東京都)

22

22と同じ

23

24

花弁折り。

25

もどします。

26

27

28

27と同じ

29

30

31

31と同じ

32

33

立体的に広げます。



24

弁折り。



「底」に穴を開けます。  
一破正方一枚形折り (!?)

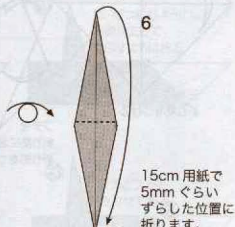
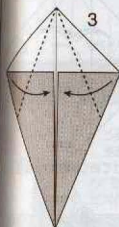
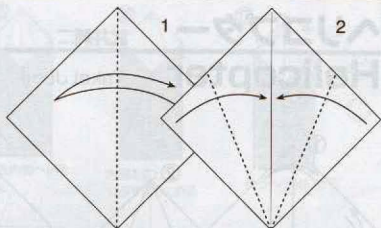

15cm用紙で  
5mmぐらい  
ずらした位置に  
折ります。

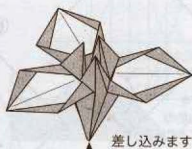
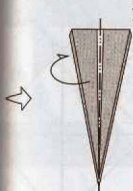

差し込みます。

自立するようにしてください。

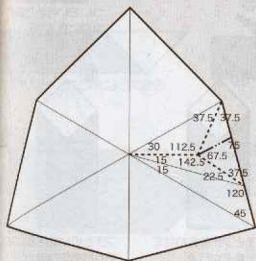

工程 29 でカドがびったり合うようになっていますが、正しくは左に示した折り目の角度でそうなります。

工程 25 で、この角度に近い折り目をつくっていますが、この折りは近似です。

# ヘリコプター Helicopter

武井純二  
Takei Junji

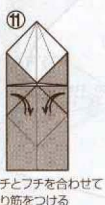
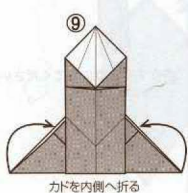
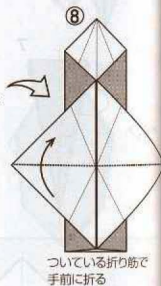
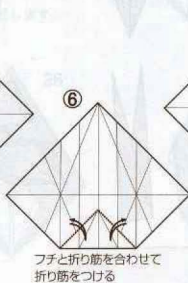
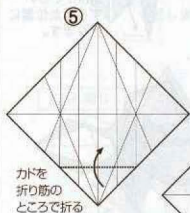
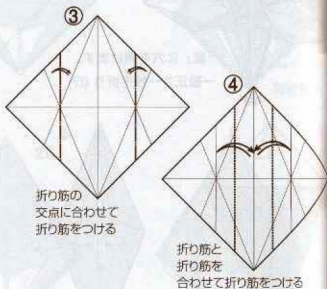
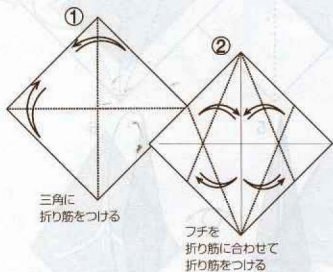



図のように  
折り筋をつける



ついている折り筋で  
内側を広げて  
つぶすように折る



カドを内側へ折る



内側を広げて  
つぶすように折る



後ろへ半分折る



カドを  
手前へ折る



カドとカドを合わせて  
折り筋をつける

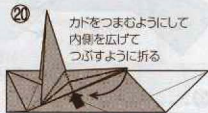

カドをつまむようにして  
内側を広げて  
つぶすように折る



カドを  
反対側へ折る



カドをつまむようにして  
ついている折り筋に  
合わせて  
折る



フチとフチを  
合わせて折る



内側を広げて  
つぶすように  
折る



カドを反対側へ折る



カドをつまむようにして  
ついている折り筋に  
合わせて折る



反対側も18~26と同じように折る



開く



折り筋をつける



つけた折り筋が  
1/3の位置になるように折る



32の形になるように  
図の折り線で折りたたむ



図のように  
カドが紙の半分  
の位置に  
なるようにする

ヘリコプター / 武井純二 (北海道)

**33** フチとフチを合せて折る

**34** かぶせ折り

**35** カドを内側へ折る

**36** 中わり折り

**37** 中わり折り

**38** カドを内側へ折る

**39** カドを後ろへ折る

**40** カドをななめに折る

**41** カドを内側へ折る

**42** カドを内側へ折る

**43** カドの中心まで折りすらす

**44** カドを内側へ折る

**45** 開く

**46** カドを折り筋から半分のところで折る

**47** フチを折り筋から半分のところで折る

**48** 反対側も45~47と同じように折る

**49** 折ったフチを下へ折る

**50** できあがり



# サザエキューブ 作・作図 川崎敏和

著「究極の夢折り紙」掲載のうず組みは汎用性が高く、  
本で紹介した22.5°以外に45°でもできます。

A turban shell cube by Toshikazu Kawasaki

パーツを12個折る

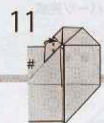
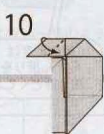
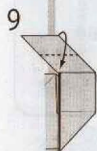
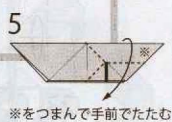
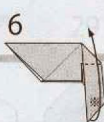
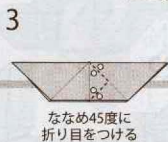
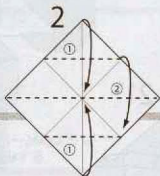
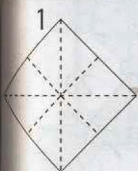
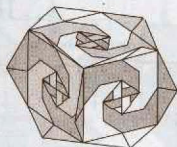

濃い部分は  
工程23の  
説明で  
使う

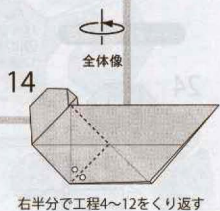
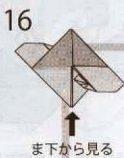

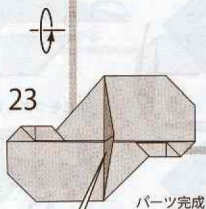
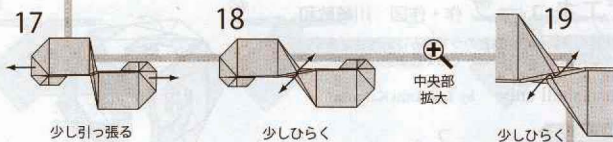

濃い三角は  
工程16の濃い部分で  
まっすぐ立ってる

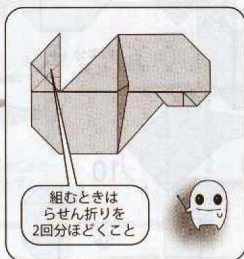

パーツを12個組む

パーツが立方体の  
辺になるように  
12個をうず組みします。

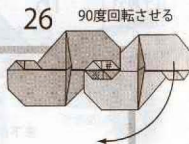
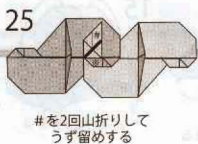
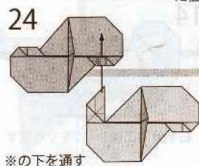

27

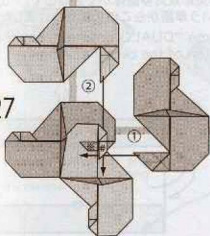

番号順に工程24~26のように  
うず組みする

28

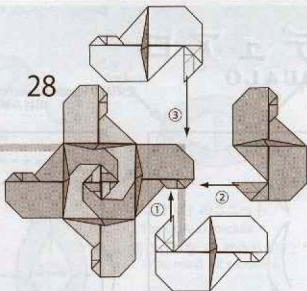

番号順にうず組みする

29のうず組みのために  
ほどいてね



30

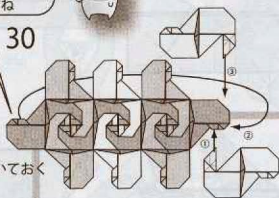

ほどいておく

番号順に工程24~26のように組む

29

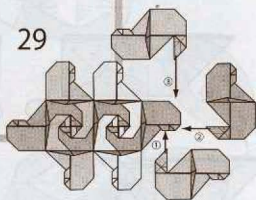

番号順にうず組みする

31

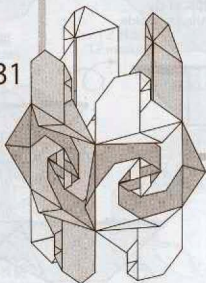

上下でうず組みして蓋と底を作る

32

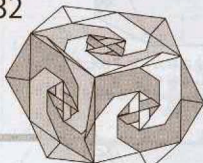

完成

30個のパーツで20面体にする  
と芙蓉やオクラの花(クリーム色)  
のイメージになる。



デュアロ/川村みゆき (佐賀県)

Design : 20100113

# デュアロ DUALO

©2010 Miyuki Kawamura  
川村みゆき

立体の中央に双対多面体ができるので、「双対(対)」という単語からこの名前をつけました。  
The name "DUALO" came from the dual polyhedron of the center of model.

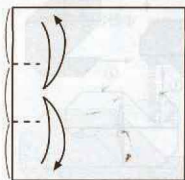

① 長方形用紙でも可能。  
Rectangle paper is also available

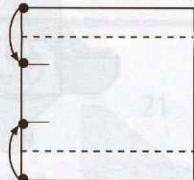

②

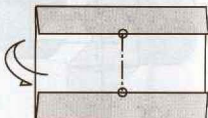

③

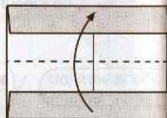

④



⑤



⑥

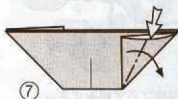

⑦ 開いてつぶす  
Open and squash.



⑧

⑧ もう一方側も同様に折る。  
Do the same on the other side.

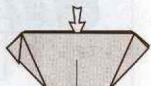

⑨ 少し開く。  
Open a bit.



⑩ 中にある小さなカドは2枚とも右側に倒しておく。  
Fold the two small flaps down to the right side.



⑪



⑫



⑬



⑭ カドを中へ入れる。  
Tuck the flap inside.



⑮





⑩  
下から折り目を押し上げて凹ませる。  
Push the bottom up, and bend the module along the crease line.



⑪  
横から見た図  
Side view.

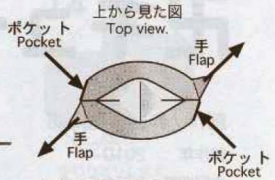

「デュアロ」のユニット  
The DUALO module  
同じものを 12 枚作ります。  
You need 12 modules.

組み方 / Assembly

⑫  
それぞれ差し込む。  
Tuck the flaps into the pockets.



⑬  
手をポケットに差し込む  
Tuck the flap into the pocket.

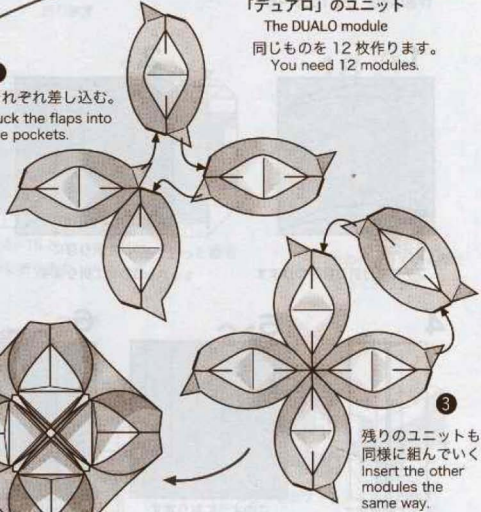

⑭  
残りのユニットも同様に組んでいく。  
Insert the other modules the same way.

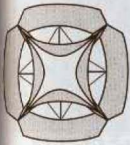

12 枚組  
12 modules



12 枚組  
12 modules

「デュアロ」  
DUALO

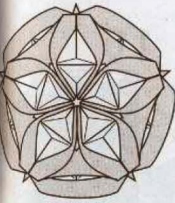

30 枚組  
30 modules



30 枚組  
30 modules

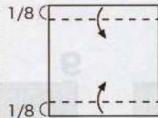

フチを折る幅を変えたり、長方形用紙を使うことで 6 枚組も可能です。

You can make six modules models by changing the width in the step 2 and/or using rectangular paper.

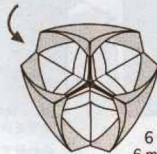

6 枚組  
6 modules

# 卍キューブ (卍 cube)

創作 / 作図 尾川知

創作年 2010

作図期間 2010.5~6

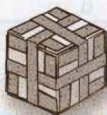

1

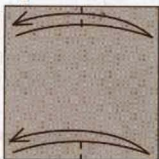

半分に折り  
フチにだけ折り目をつけます

2

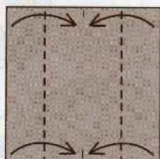

つけた折り目に  
合わせて折ります

3



3等分する折り目を  
すべての層につけます

4

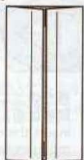

すべて開きます

5



このようになります

6

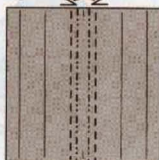

ついている  
折り目を真ん中に  
合わせて段折りします

7



もとにもどします

8

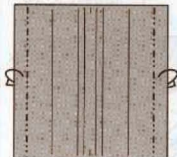

9



フチを折り目に  
合わせて折ります

10

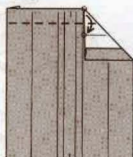

〇と〇を合わせて  
折ります

11

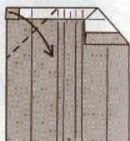

フチを折り目に  
合わせて折ります

12

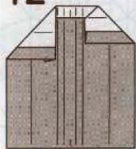

下側も 9~11 と  
同じように折ります

13

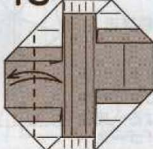

フチを折り目に合わせて  
折ります

14

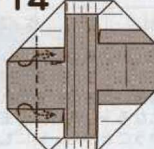

中わり折りします

15

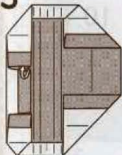

ヒダをすきまに  
さしこみます

16

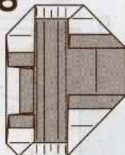

右側も 14~15 と  
同じように折ります

17

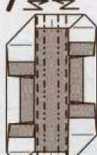

6で折った線  
折ります

18



色のかわっている線に  
そって折ります

19



色のかわっている線に  
そって折り目をつけます

20



つぎ手  
ポケット  
同じものを6つ  
つくります

21

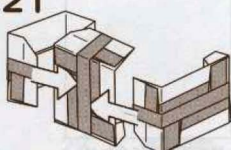

つぎ手をポケットにさしこみます

22

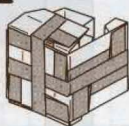

以下、同様に 6つを組み合せます



一面を正面から  
見たところ

23

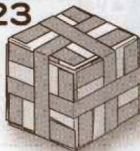

できあがり



# Ghost Cube ~ 畳める立方体 Skeleton

By Kasumi

作 / 2009.5 霞誠志

~ [Ghost Cube] の名の由来 ~

立方体のスケルトンが消えたり現れたりすることに加え、四角い立方体が畳まれて平らになった時に五角形になる ~ 四(死)が五(後)になる ~ 死後の世界ということから、いにしゑより「ゴーストキューブ」と呼ばれていた・・・はずだあ~! という作者の熱望=妄想から名付けられました。

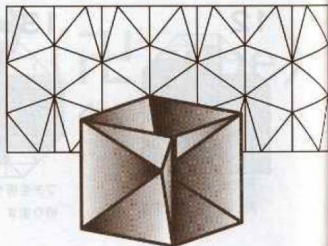

1 / 8 の位置に折り筋を付ける

1. 付ける

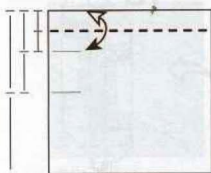

2.

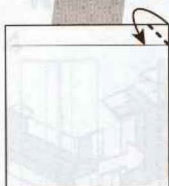

縁を折り筋に合わせて折る

3.

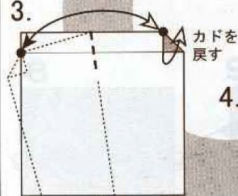

●印を合わせて折り筋を付ける

4.

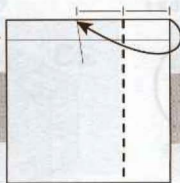

カドを折り筋に合わせて折る

9.

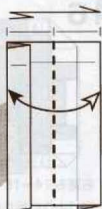

半分に折って折り筋を付ける

10.



[8]の状態に戻す

8.



反対側へ折る

7.



縁を合わせて折る

6.

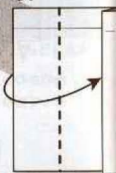

縁を合わせて折る (位置に注意)

5.

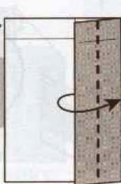

縁を合わせて折る





12. 折り筋を付けたら全て開く

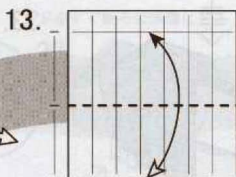

13. 縁を折り筋に合わせて折り筋を付ける

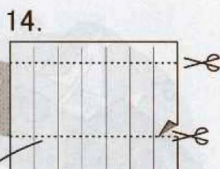

<<図の位置で切る>>

切り離した長方形を使用します。  
(この作品には  $13/3\sqrt{2} : 7$  の比率の用紙が必要になります。しかしここでは、簡単に正方形から2枚分の用紙を取り出せるように近似値を使っています)



11. 反対側も [8~9] と同じように折る



16. 縁を合わせて折り筋を付ける



15. 縁を折り筋に合わせて折る

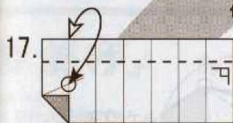

17. 丸印の交点に縁を合わせて折り筋を付ける



18. 反対側も [15~17] と同じように折って折り筋を付ける

まとめて折ると紙の重なりで、ずれ易いので出来れば1ヶ所毎に折り筋を付けて下さい。

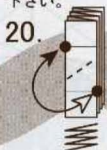

20. ●印を合わせて折り筋を付ける

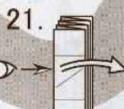

21. 軽く開く



22. [20]で付けた折り筋を全て山折りに折り変えて各々のカドをかぶせ折り&中割折りしながら閉じる

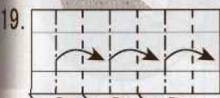

19. ジャバラに折ってまとめる

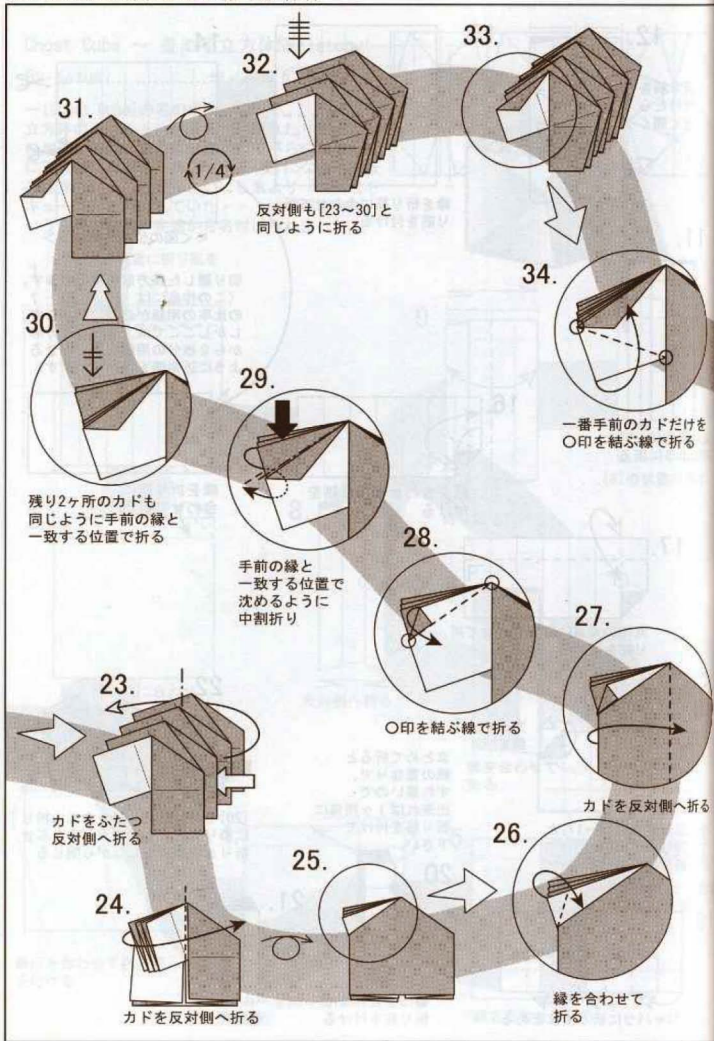

36.

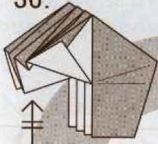

残り2ヶ所も同じようにして、  
それぞれカドを隙間に差し込む

カドをすぐ後ろの隙間に折る

37.



反対側も [34~37] と  
同じように折る

38.



カド交差させるように  
引き寄せて立体化する

35.

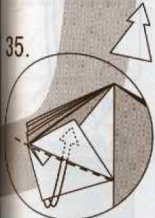

小さいカドを巻き込  
みながら隙間に差し  
込んで開きを止める

39.

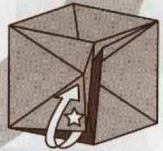

濃い色の部分を下から  
引き出して☆印のカド  
の上にかぶせる

40.

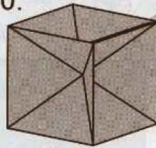

完成

## 『招まけ』 By Kasumi

Ghost Cube II  
~ 平行六面体のスケルトン ~

Ghost Cubeの平行六面体バージョンです。こちらはまだ、折り  
手順がありません。展開図を載せておきますので参考にして  
下さい。

< (用紙の縦横比) 3.228 : 7 >

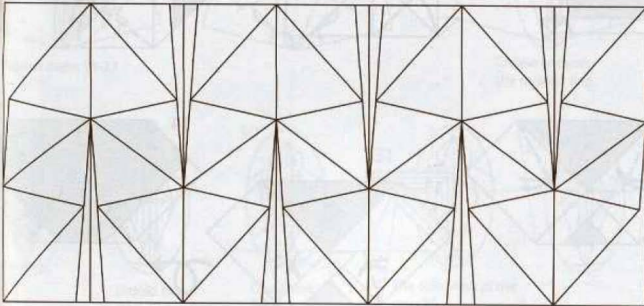
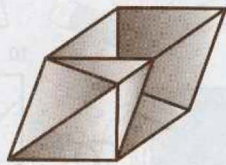

**The Tiger cub, version 2**  
 (April 2010)

Victoria Serova (Russia)  
[Http://vs-origami.narod.ru](http://vs-origami.narod.ru)

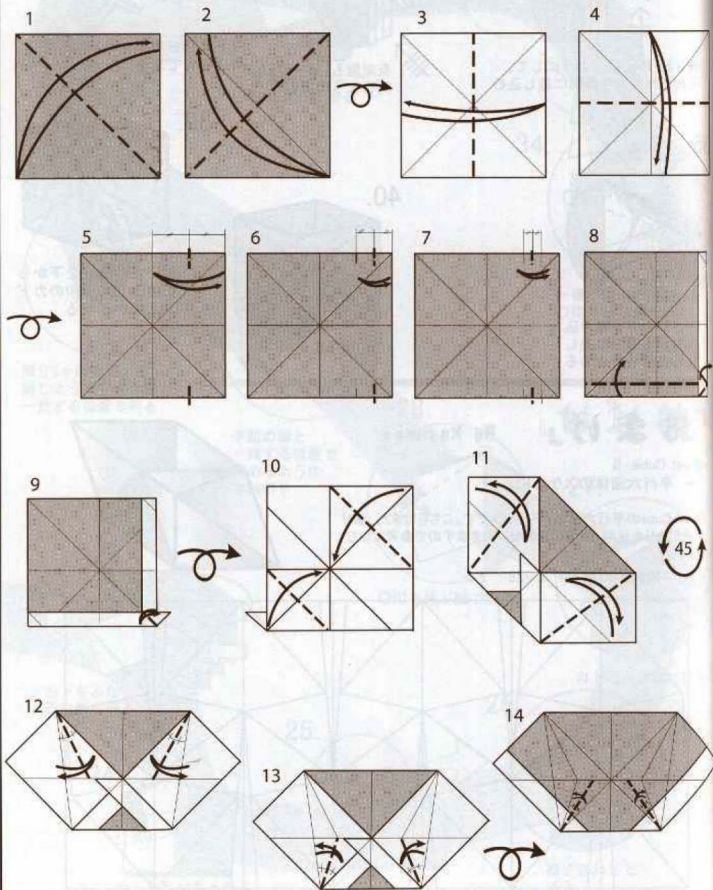



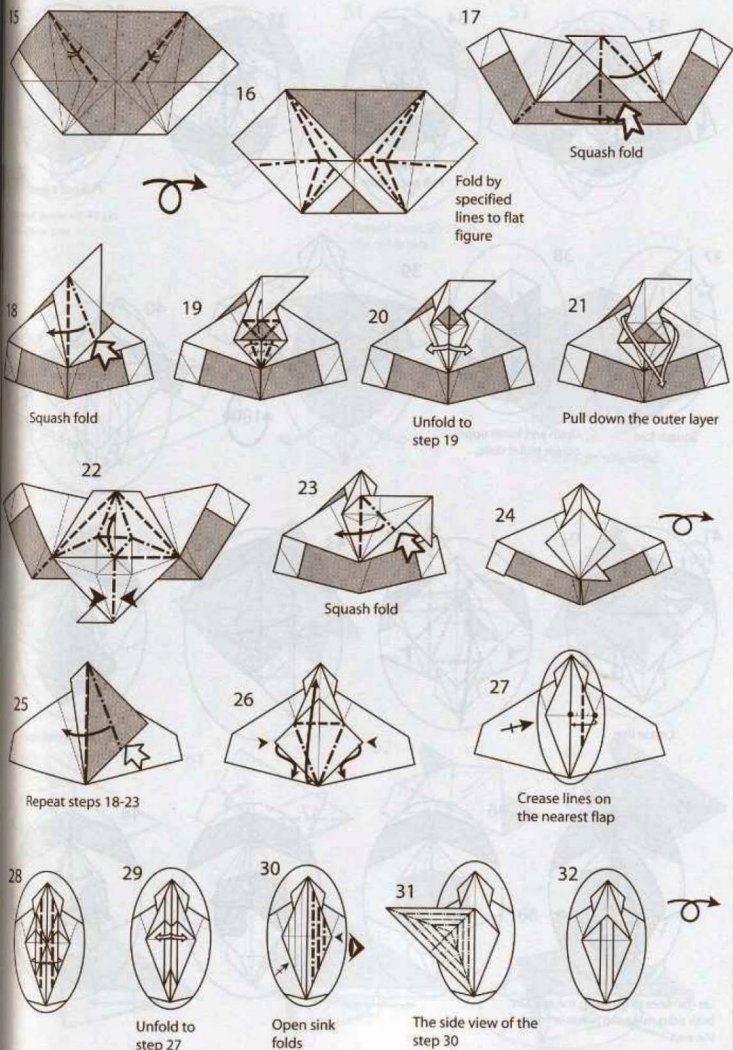

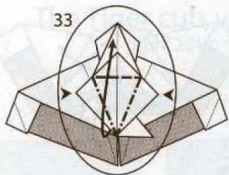

33



34

Pull out a layer



35



36

Pull out a layer



37

Squash fold



38

Open and lower upper corner to flat state.

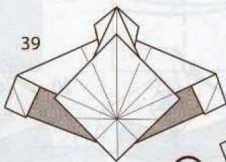

39

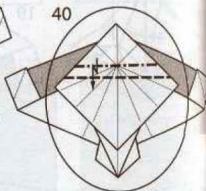

40

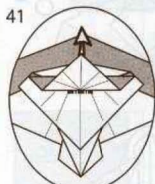

41

Crease line

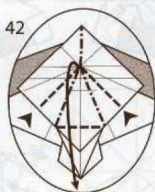

42

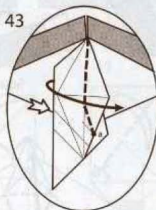

43



44

Pleat as was created on step 40

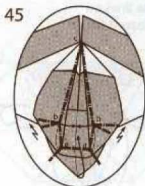

45

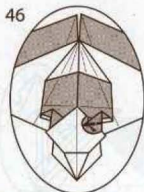

46

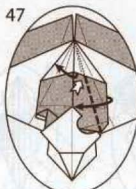

47

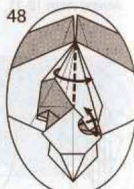

48

Let (bc) lines to go along the axis. On both sides make the pleats to form the ears

**Japão Burajirujin**

[www.japaoburajirujin.blogspot.com](http://www.japaoburajirujin.blogspot.com)

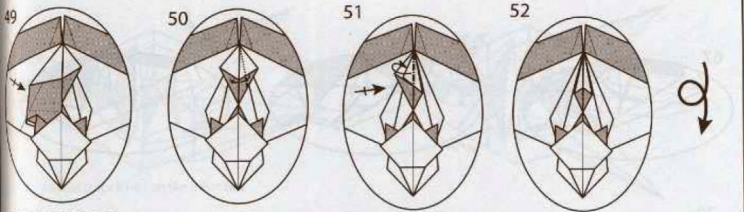

Repeat steps 46-48 on the other side

Repeat steps 50-51 on the other side

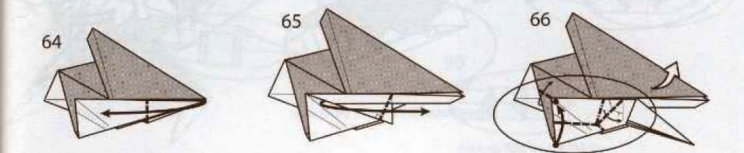
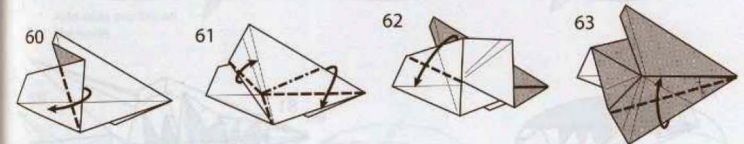
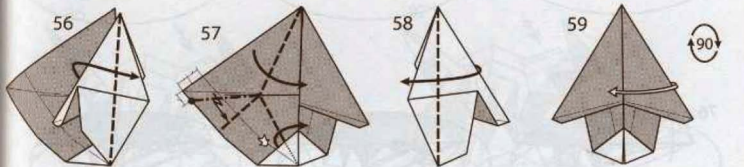
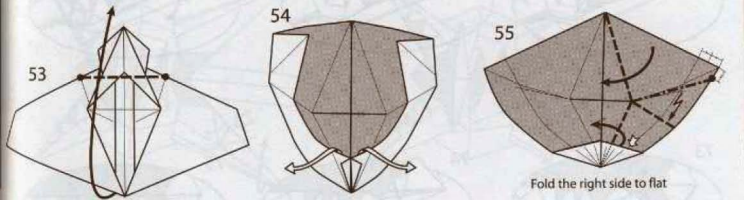



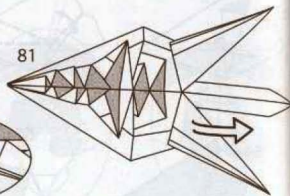
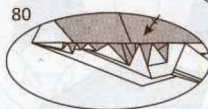
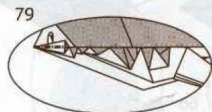
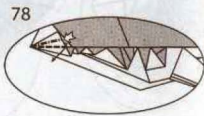
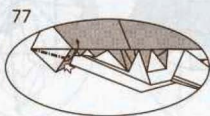
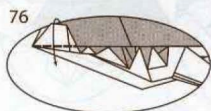
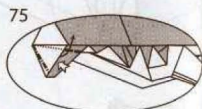
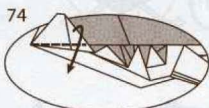
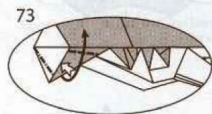
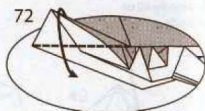
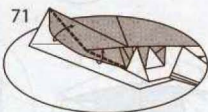
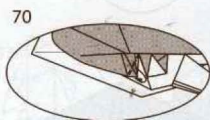
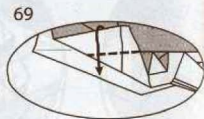
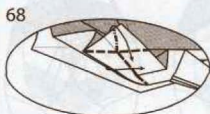
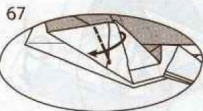

Repeat steps 59-79 on the other side



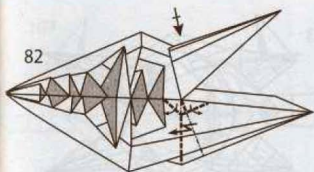

82

Repeat steps 81-82 on the other side

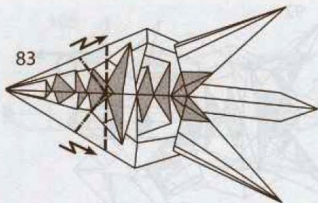

83

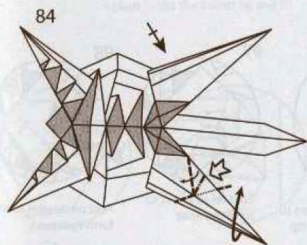

84

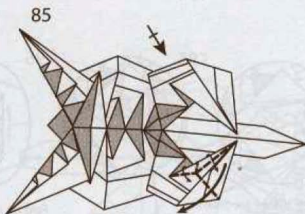

85

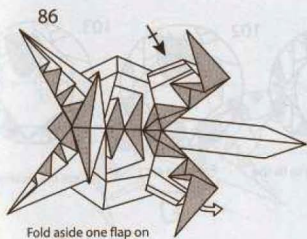

86

Fold aside one flap on the inside

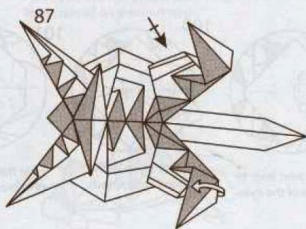

87

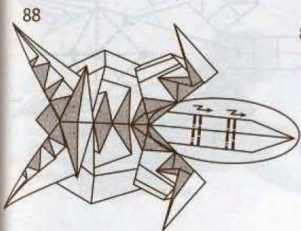

88



89

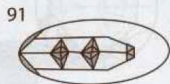

91

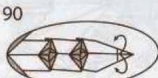

90

Reverse fold on the tail tip

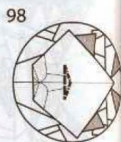
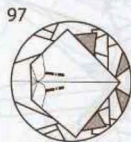
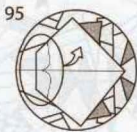
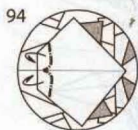
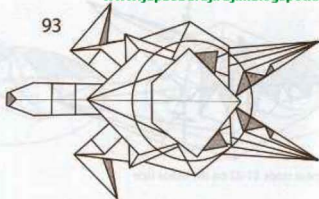
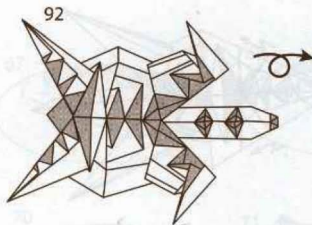

In the steps 94-101 we are creating the lines needed to form the face. Though here all is showed on the flatness, really each fold is voluminous. Don't flatten the figure!

Fold on all layers to form the nose tip

Fold on all layers to form the nose

Fold on nearest layer to form eyebrows

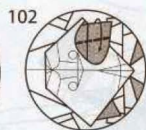
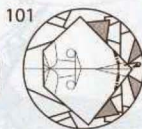
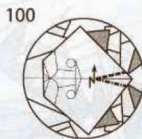
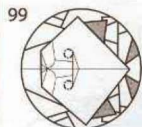

Fold on nearest layer to form pupils of the eyes

Pleat to make the head voluminous

Hide the corner to fix the previous fold.

Form the ear

Form the second ear

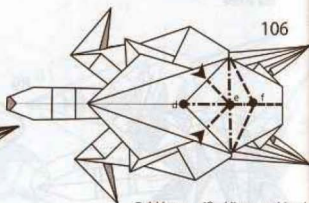
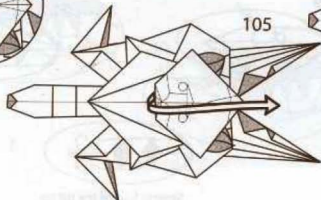
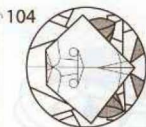

Fold by specified lines pushing the layer from behind through the aperture of the head

107

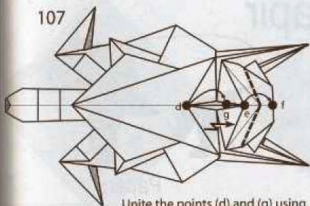

Unite the points (d) and (g) using a pleat. Unite the points (e) and (f)

108

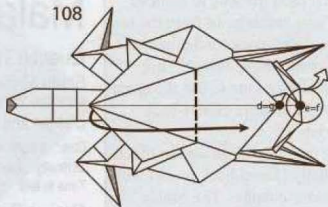

109



110



Spread the triangle to form the lower jaw

111

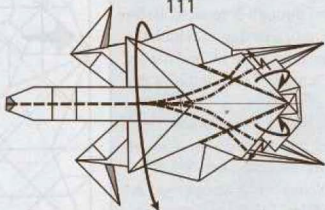

Fold by axis forming the chest. Finally form the head with the lines creased on previous steps.

112

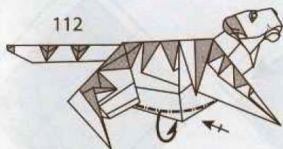

Form the feet making them thicker. Give the pose to the cub.





I first used the way to achieve the ears coming out from the top of a closed-back model in a previous Rhino design. This then allowed me to use the same method in more closed-back models.

The next challenge was to make a totally closed-back model with a colour-change. The Malay Tapir was very suitable for this challenge, and by adding a strip-graft this was possible. I went through 3 versions before getting to a design of which the proportions were ok and the cp was "clean." I then left it at that.

Then later, I was contacted by a folder who is also a member of the Malaysian Nature Society ([www.mns.my](http://www.mns.my)), whose logo is the Malay Tapir. He wanted to make an origami Malay Tapir for his society's 70th anniversary. I felt too ashamed to send him diagrams for my initial attempt at the Malay Tapir, because the folding sequence was not very good and there were some tricky unorthodox folds. So I set off on making a more "user-friendly" model.

I used many parts of the first version and then came up with this current version, which in my eyes is a better design and has a fun folding sequence too. The CP is also a lot cleaner than the first attempts.

Most papers will work well, but wet-folding to make the curved hind legs will give the best result.

## Malay Tapir

Quentin Trollip

South Africa / Canada

[www.liveorigami.com](http://www.liveorigami.com)

Design and diagram info:

Date: 8 April 2010

Difficulty: High Intermediate

Time to fold: 1 Hour



Paper:

Single Uncut Square

Size: 35 cm

Color: White / Black

Type: Kami

Foil

Wet-Fold

Good

Good

Best

Crease Pattern:

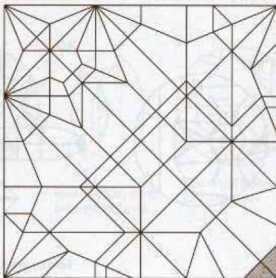

Ratio: 0.47 Length

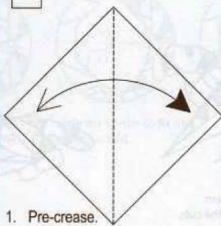

1. Pre-crease.

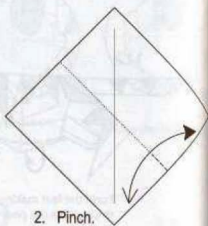

2. Pinch.

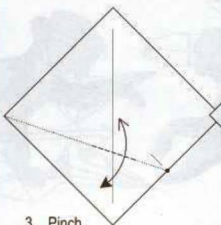

3. Pinch.

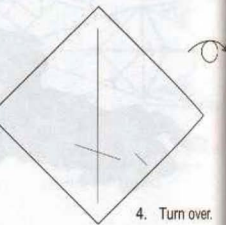

4. Turn over.



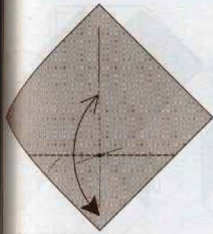

5. Valley-fold and unfold.

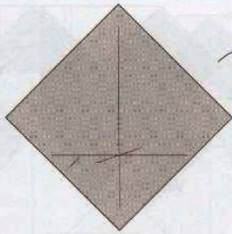

6. Turn over.

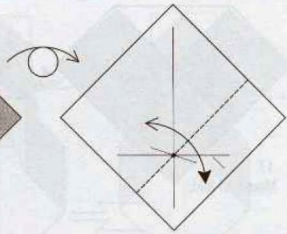

7. Valley-fold and unfold.

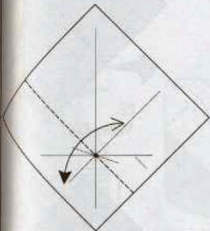

8. Valley-fold and unfold.

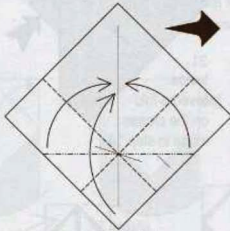

9. Preliminary-fold.  
Enlarge.

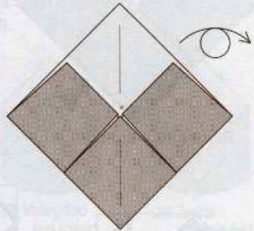

10. Turn over.

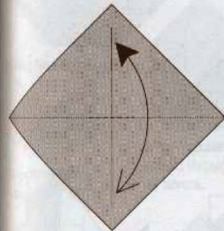

11. Pinch.

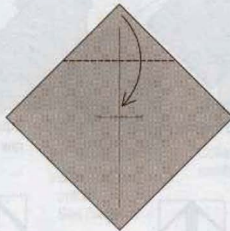

12. Valley-fold.

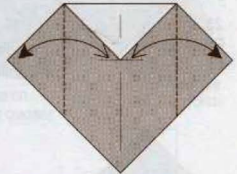

13. Valley-folds and unfold.

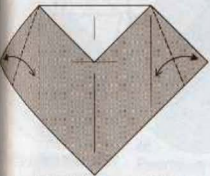

14. Valley-folds and unfold.

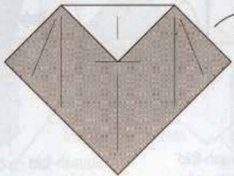

15. Turn over.

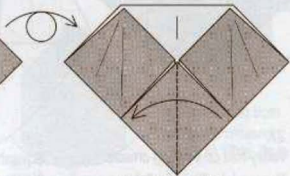

16. Valley-fold.

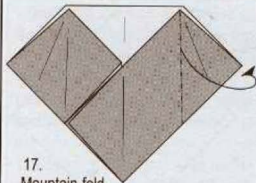

17. Mountain-fold.

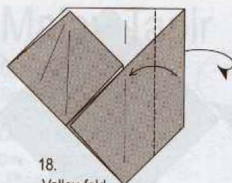

18. Valley-fold.



19. Unfold.

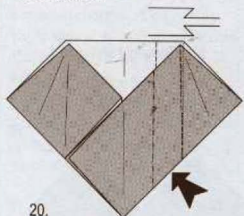

20. Reverse-fold in and out.

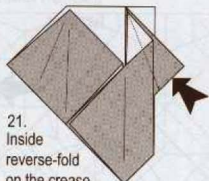

21. Inside reverse-fold on the crease made in step 14.

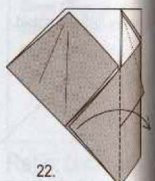

22. Valley-fold.

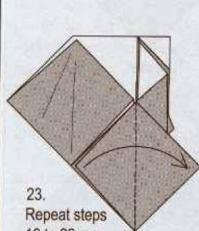

23. Repeat steps 16 to 22 on the left.



24. The result. Unfold the raw corner.

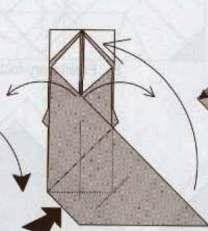

25. Squash-fold the raw corner up.

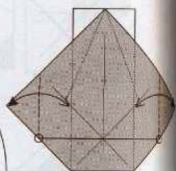

26. Valley-folds and unfold.

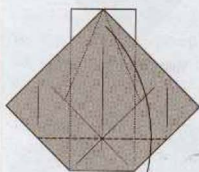

27. Valley-fold on existing crease. The model will not lie flat.

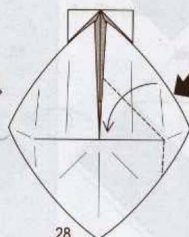

28. Squash-fold the raw edge.

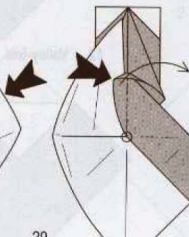

29. Squash-fold. The point will then lie flat.

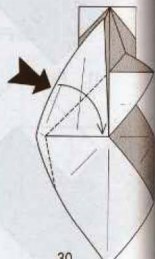

30. Repeat steps 28 to 29 on the left.

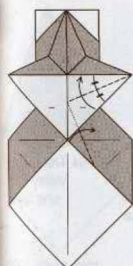

31. Swivel-fold.

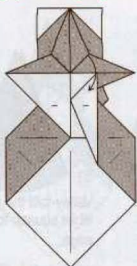

32. Valley-fold.

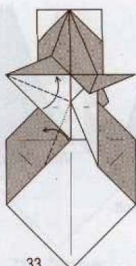

33. Repeat steps 31 to 32 on the left.

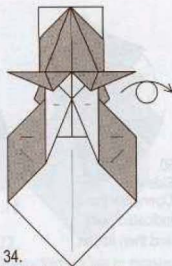

34. Like this. Turn over.



35. Enlarge.

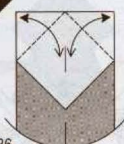

36. Valley-folds and unfold.

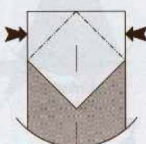

37. Inside reverse-folds.

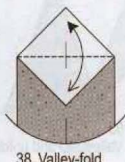

38. Valley-fold and unfold.

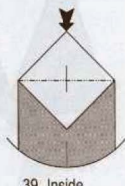

39. Inside reverse-fold.



40. Valley-fold the raw corner up.

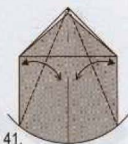

41. Valley-folds and unfold through all layers.

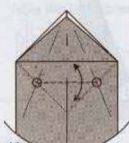

42. Valley-fold and unfold. See markers.

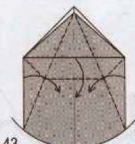

43. Collapse on existing creases.

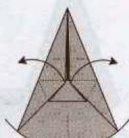

44. Unfolds.



45. Pull out the raw edge and hidden corner.

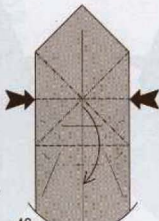

46. Preliminary Fold on the existing creases.

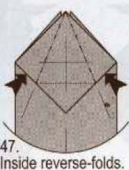

47. Inside reverse-folds.

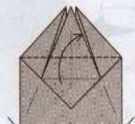

48. Lift the point slightly.

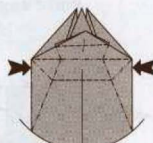

49. Open-sink on both sides on creases made in steps 41 to 43.



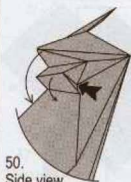

50. Side view.  
Open-sink the indicated point and then flatten.

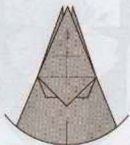

51. The result.

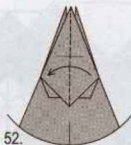

52. Valley-fold one layer.

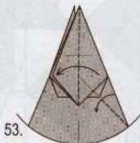

53. Valley-fold the next layer, while squashing the edge.



54. The result.  
Valley-fold one layer.

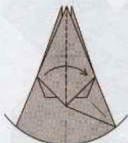

55. Repeat steps 52 to 54 on the left.

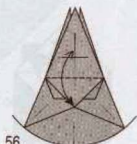

56. Valley-fold and unfold.

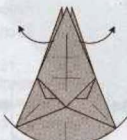

57. Unfold the raw edges.

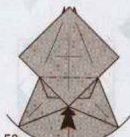

58. Closed-sink the triangle.

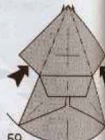

59. Inside reverse-fold.

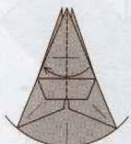

60. Valley-fold.

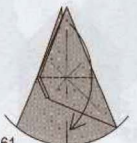

61. The result.  
Valley-fold the point down.

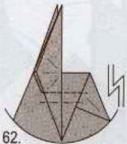

62. Pleat-fold the point.

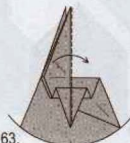

63. Valley-fold one layer to the right.

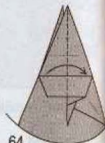

64. Repeat steps 60 to 63 on the left.

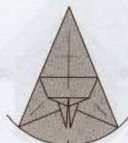

65. The result.  
Scale change.

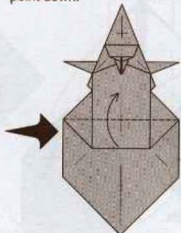

66. Valley-fold.



67. Closed-sink.

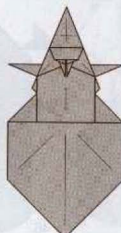

68. Turn over.



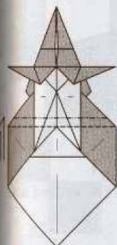

69. Pleat -fold.

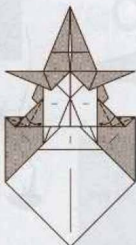

70. Swivel-folds.

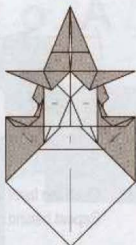

71. Turn over.

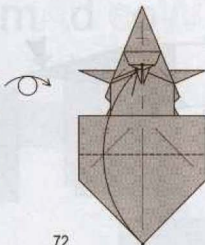

72. Valley-fold marker to marker.

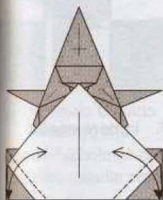

73. Valley-folds and unfold.

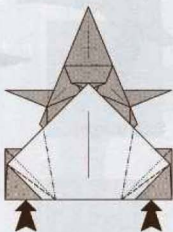

74. Inside reverse-folds.  
Note the references.

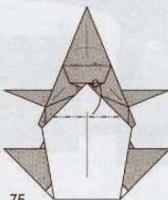

75. Mountain-fold the raw corner.

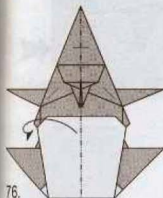

76. Mountain-fold in half.  
Rotate.

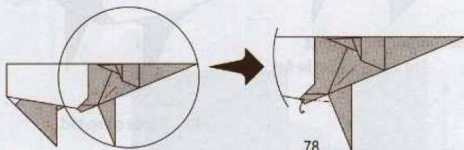

77. Enlarge.

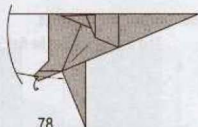

78. Mountain-fold.  
Repeat behind.

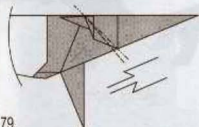

79. Make a small crimp-fold to rotate the head down slightly.

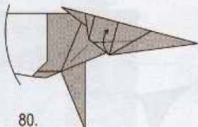

80. Valley-fold the trapped layer.  
Repeat behind.

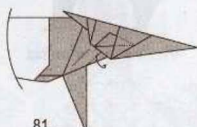

81. Mountain-fold.  
Repeat behind.

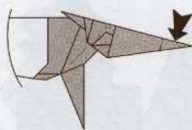

82. Inside reverse-fold.

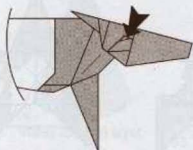

83. Open the layer to shape the eye.  
Repeat behind.

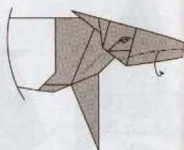

84. Round the head and nose.

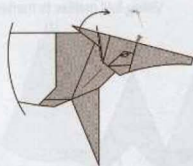

85. Shape the ears.

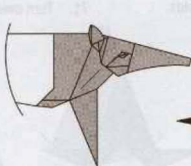

86. Scale change.

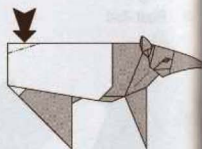

87. Inside reverse-fold.

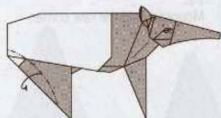

88. Shape the hind legs.  
The model will not lie flat.

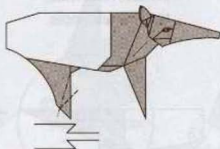

89. Inside crimp-fold.

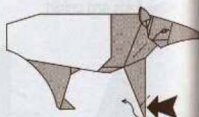

90. Inside reverse-fold.

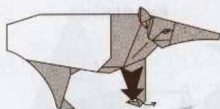

91. Inside reverse-fold.



92. Shape the body 3D.



Malay Tapir.

# vaCa LoCA (mAd coW)



© Fernando Gilgado  
 (Spain) 2009  
 elfernan3@hotmail.com  
 gilgado.pajarita.org

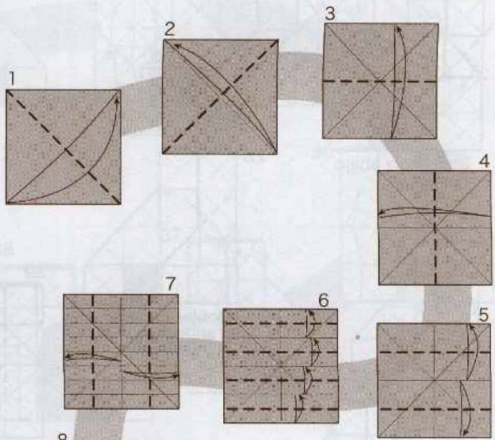

**Japão Burajirujin**  
[www.japaoburajirujin.blogspot.com](http://www.japaoburajirujin.blogspot.com)

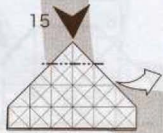
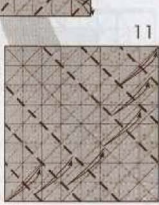
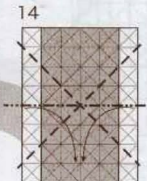
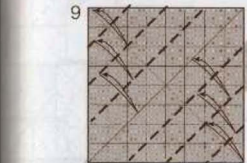

Hundir

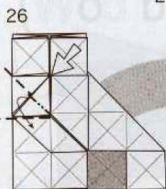

26  
Tirar hacia abajo  
y aplastar

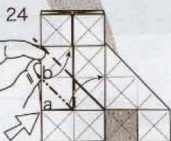
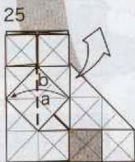
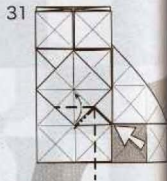
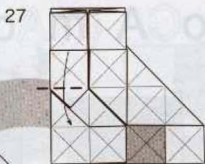

24  
Aplastar la esquina "a"

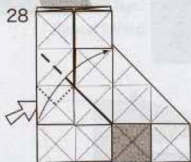

28  
Doblar en valle  
y aplastar por  
el interior

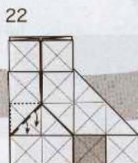
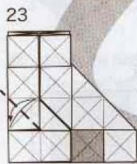
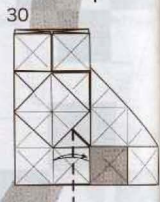
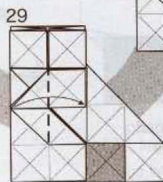

22  
Sacar el papel  
del interior

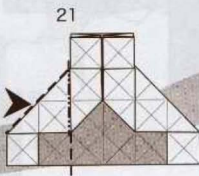

20  
Levantarse aplastando  
las esquinas interiores

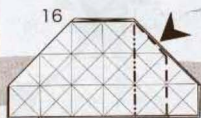

16  
Pliegue hundido  
escalonado



17  
Pliegue hundido  
escalonado

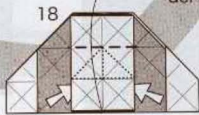

18  
Levantarse aplastando  
las esquinas  
interiores

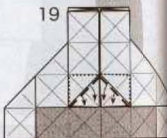

19  
Sacar el papel  
del interior



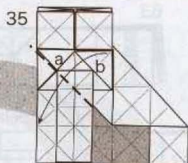
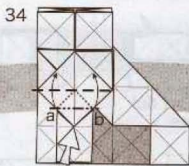
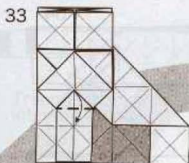

Sacar el papel del interior y plegar simétricamente

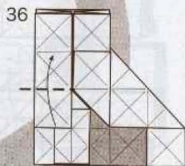
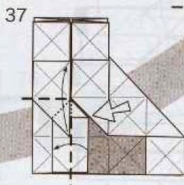
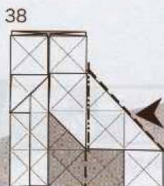

Sacar el papel del interior

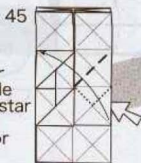
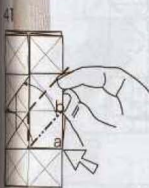

Doblar en valle y aplastar por el interior



Tirar hacia abajo y aplastar



Sacar el papel del interior y plegar simétricamente



## Japão Burajirujin

[www.japaoburajirujin.blogspot.com](http://www.japaoburajirujin.blogspot.com)

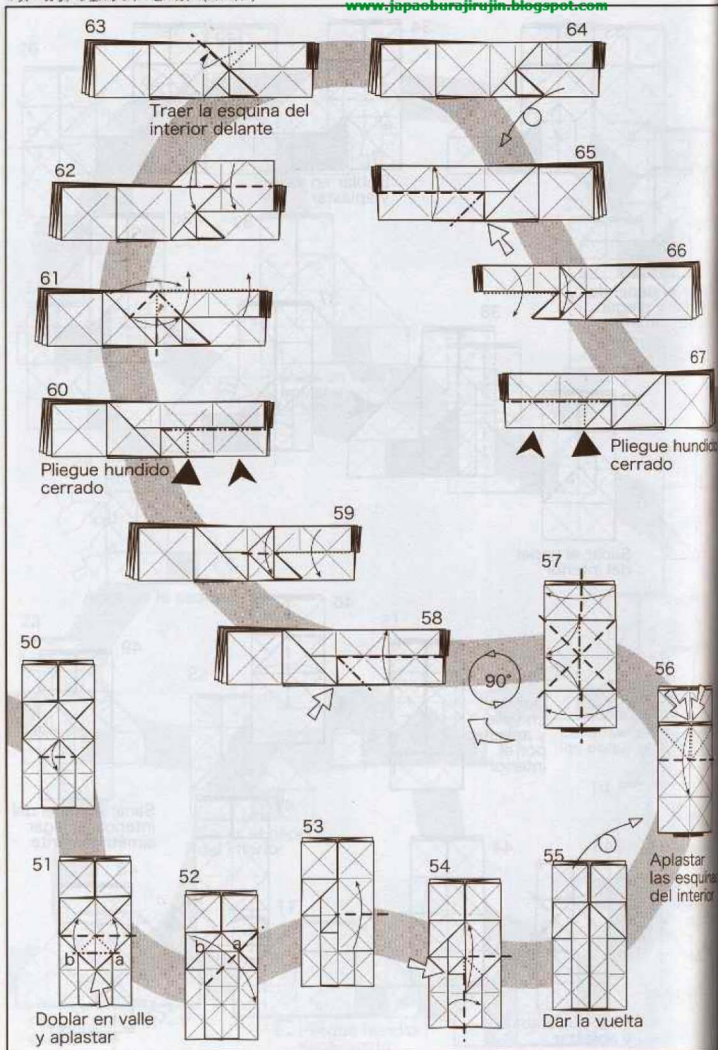

70

Traer la esquina del interior delante

71

69

72

68

73

74

75

Dar la vuelta

76

85

Repetir detrás

77

84

Repetir detrás

78

83

79

80

81

Vista interior

Pliegue escalonado en la punta interior

82

Repetir el paso 81 en la otra punta con un ángulo diferente



マッド・カウ/フェルナンド・ヒルガド (スペイン)

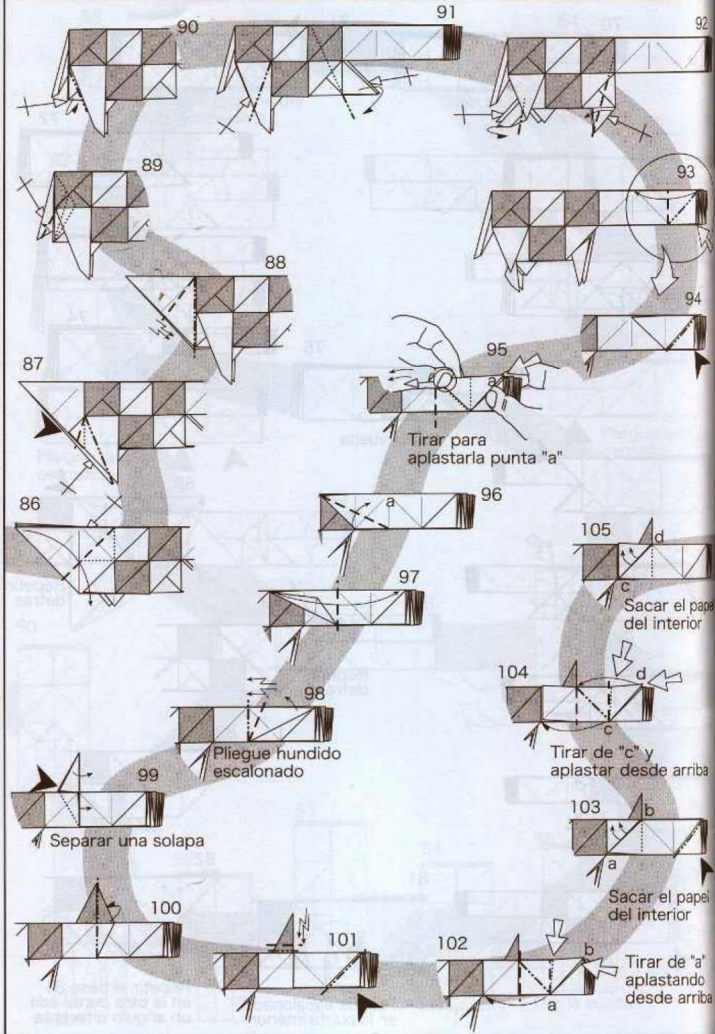



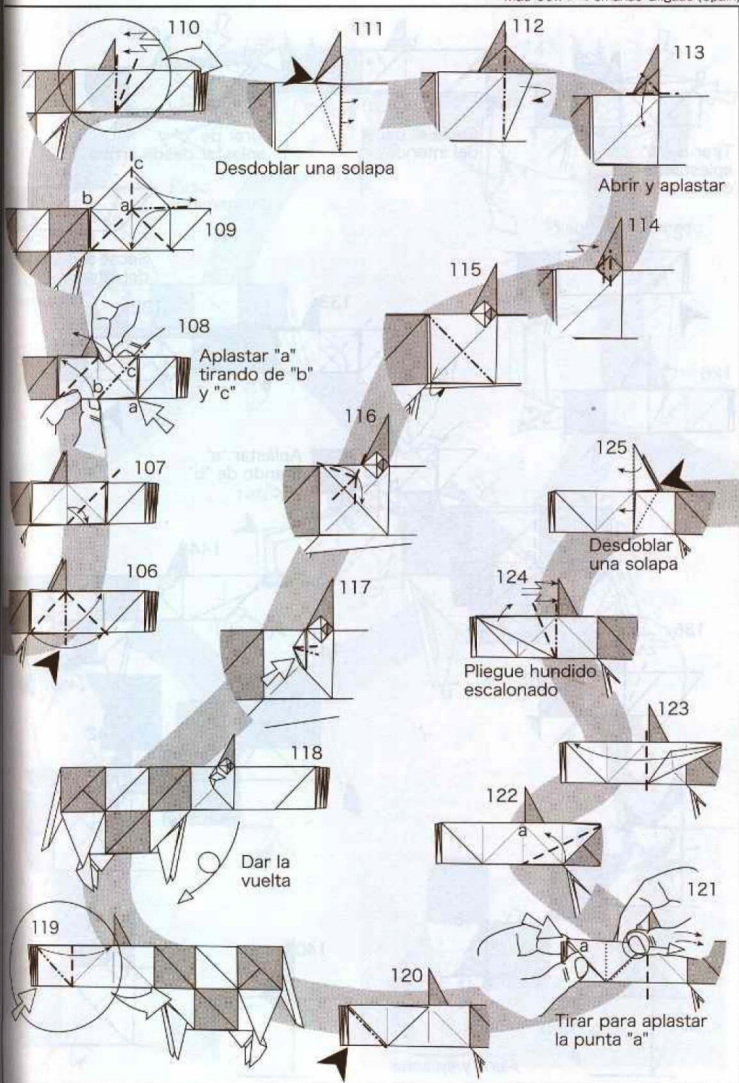

マッド・カウ/フェルナンド・ヒルガド (スペイン)

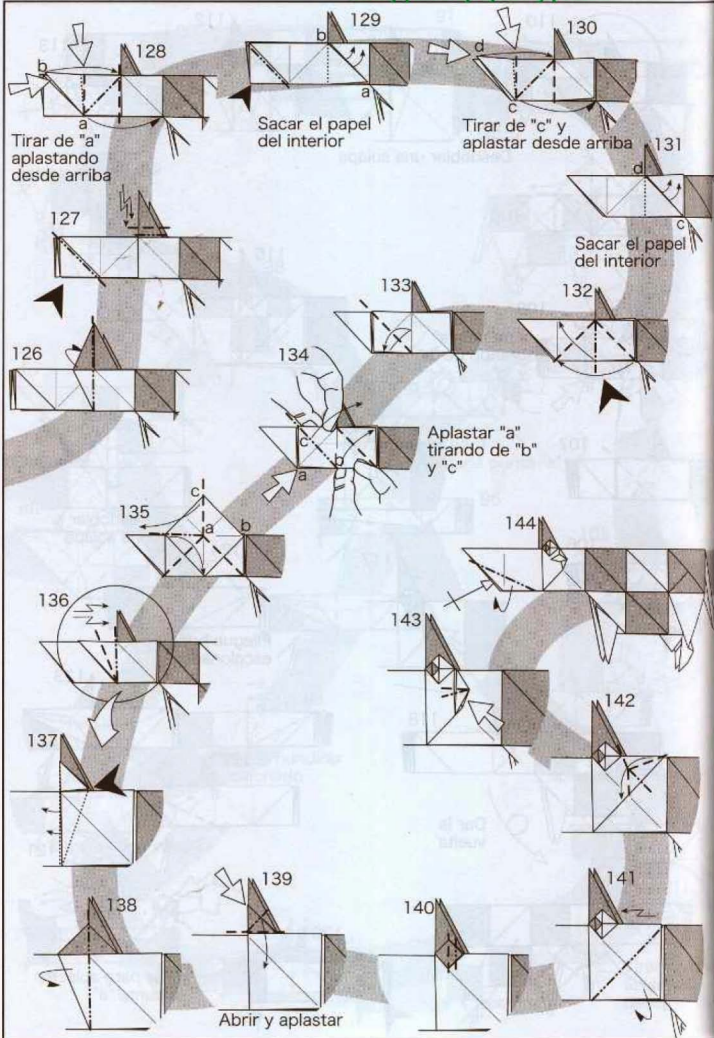

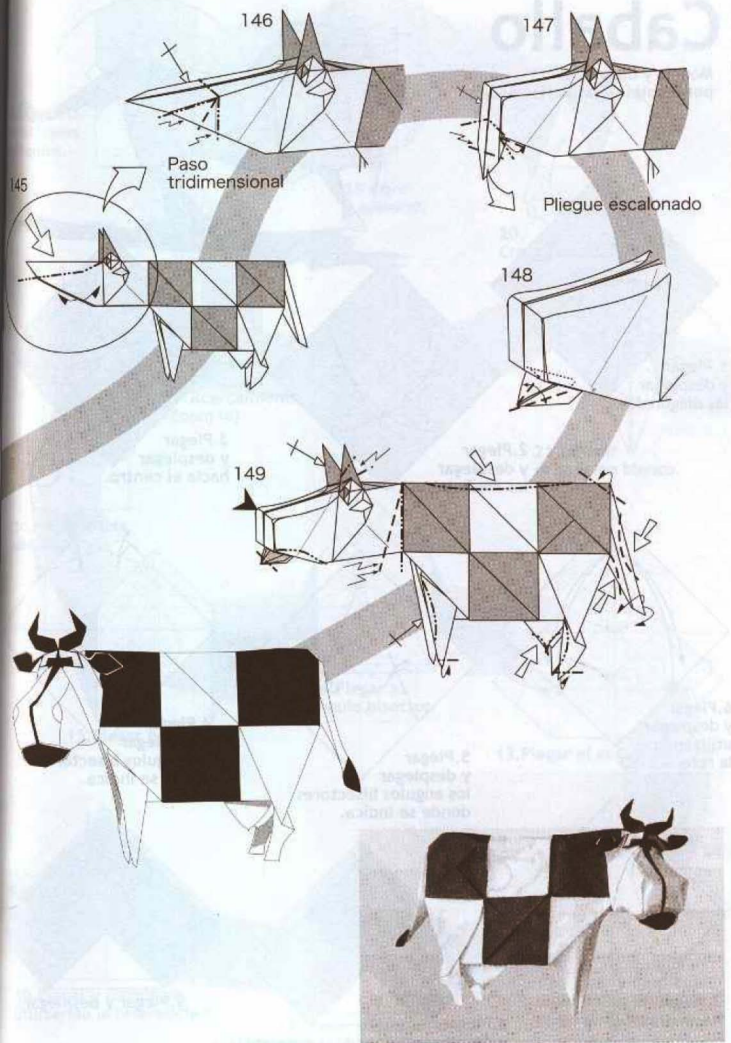

# Caballo

Modelo y diagramas  
por Nicolás Gajardo Henríquez

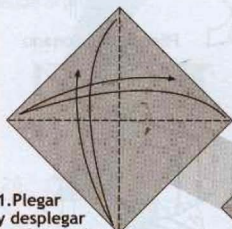

1. Plegar y desplegar las diagonales.

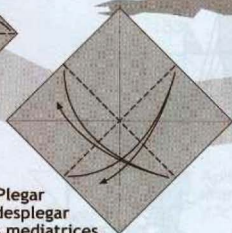

2. Plegar y desplegar las mediatrices.



3. Plegar y desplegar hacia el centro.

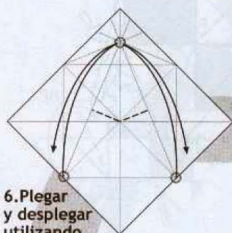

4. Plegar y desplegar utilizando la referencia ○

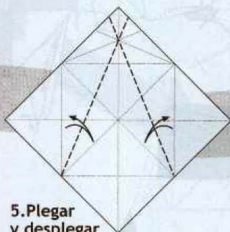

5. Plegar y desplegar los ángulos bisectores donde se indica.

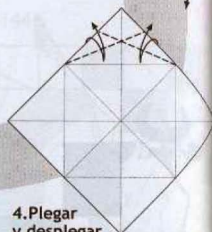

6. Plegar y desplegar los ángulos bisectores donde se indica.



7. Plegar hacia atrás.

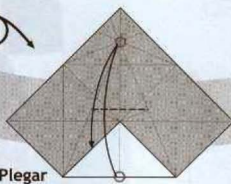

8. Plegar y desplegar utilizando la referencia ○

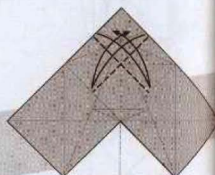

9. Plegar y desplegar



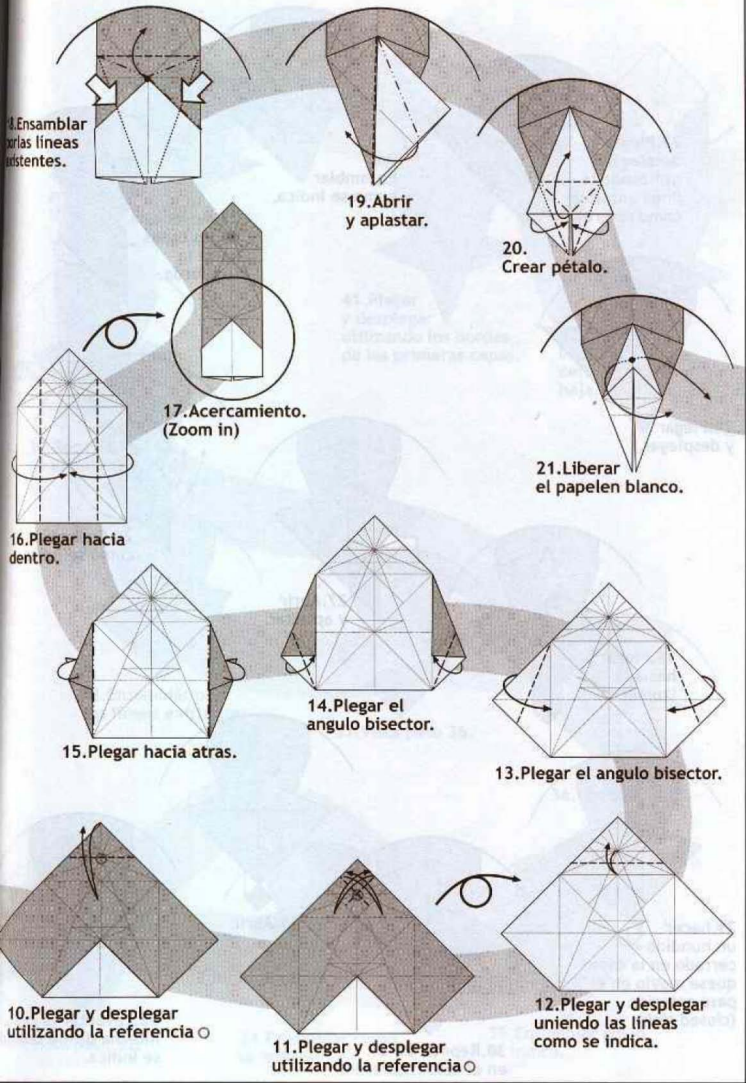

18. Ensamblar por las líneas restantes.

19. Abrir y aplastar.

20. Crear pétalo.

17. Acercamiento. (Zoom in)

21. Liberar el papelen blanco.

16. Plegar hacia dentro.

14. Plegar el angulo bisector.

15. Plegar hacia atras.

13. Plegar el angulo bisector.

10. Plegar y desplegar utilizando la referencia ○

11. Plegar y desplegar utilizando la referencia ○

12. Plegar y desplegar uniendo las líneas como se indica.

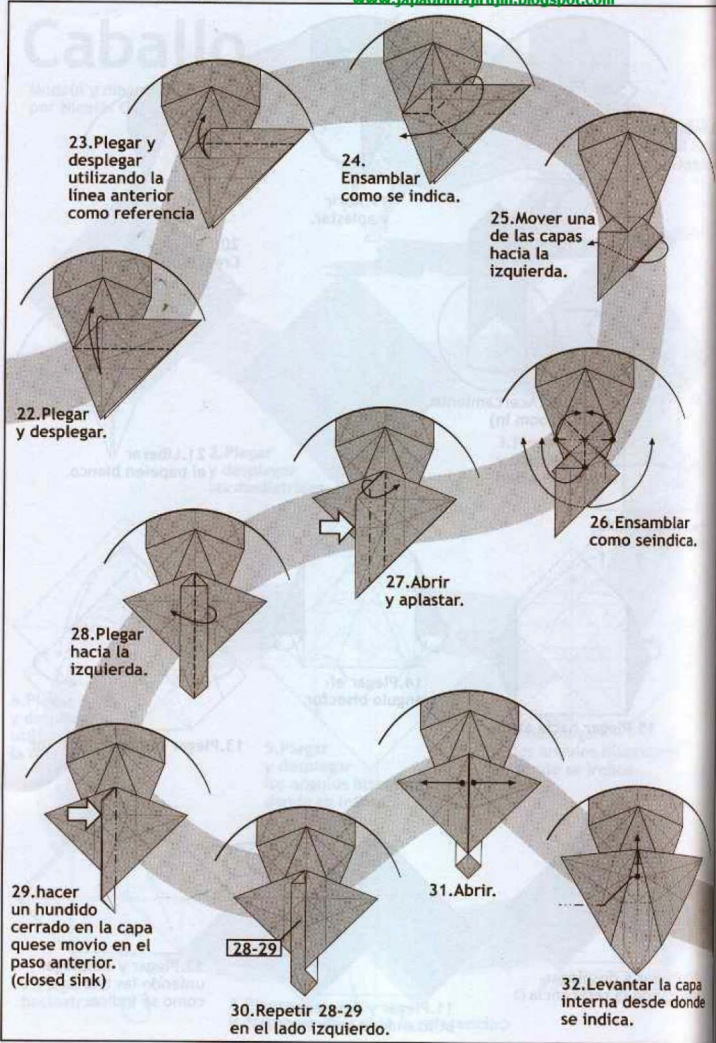

23. Plegar y desplegar utilizando la línea anterior como referencia

24. Ensamblar como se indica.

25. Mover una de las capas hacia la izquierda.

22. Plegar y desplegar.

26. Ensamblar como se indica.

27. Abrir y aplastar.

28. Plegar hacia la izquierda.

29. hacer un hundido cerrado en la capa que se movió en el paso anterior. (closed sink)

28-29

30. Repetir 28-29 en el lado izquierdo.

31. Abrir.

32. Levantar la capa interna desde donde se indica.

40. Fin acercamiento.  
(Zoom out)

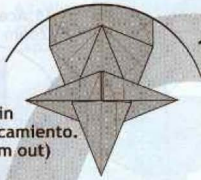

41. Plegar y desplegar utilizando los bordes de las primeras capas.

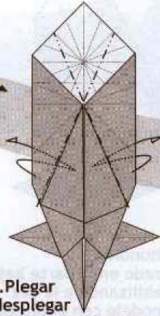

42. hacer un hundido cerrado en la parte baja.

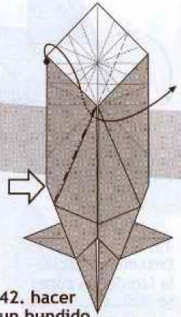

35-38

39. Repetir 35-38 en el lado izquierdo.

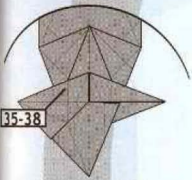

38. Ensamblar por las líneas existentes.

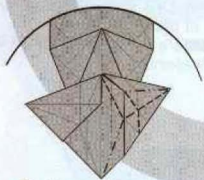

37. Vista paso 36.

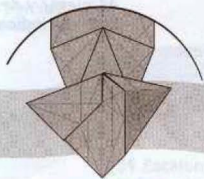

36. desplegar 35.

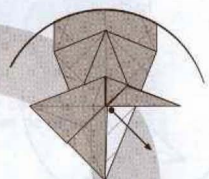

34. Ensamblar como se indica.

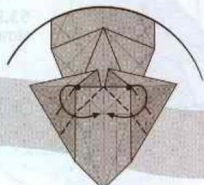

35. Ensamblar como se indica.

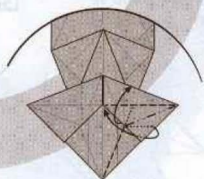

33. Vista paso 32.

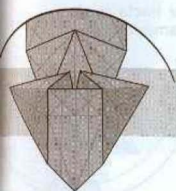



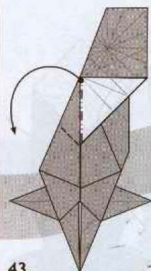

43. Ensamblar hacia la izquierda como se indica.

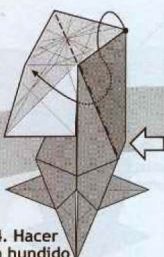

44. Hacer un hundido cerrado en la parte baja estabilizando a la vez el modelo con el pliegue superior.

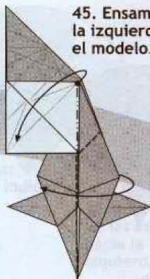

45. Ensamblar hacia la izquierda y cerrar el modelo.

46. Acercamiento. (Zoom in)

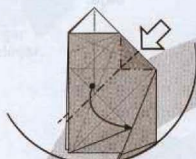
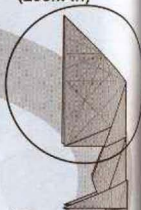

49. Hundir y mover las capas simétricamente hacia atrás.

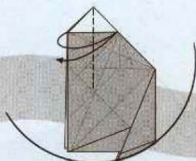

48. plegar y desplegar como se indica.

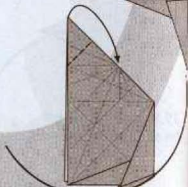

47. Plegar hacia atrás.

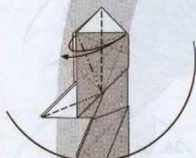

50. Esamblar y desarmar como se indica.

52. Repetir 50-51 atrás.

50-51



51. Ensamblar como se indica.

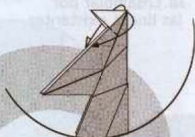

53. Plegar hacia abajo simétricamente.

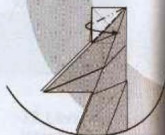

54. Abrir y aplastar.



63. Mirar entre las capas

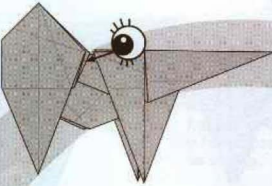

62. Plegar hacia arriba.



64. Aplastar levantando la parte en 

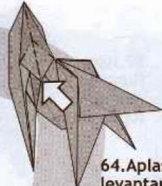

65. Cerrar.

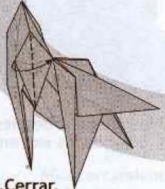

61. Liberar el papel bajo la capa superior y plegar los por sus líneas existentes.



59. Escalonar como se indica a través de todas las capas.

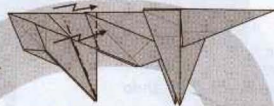

60. Plegar hacia la izquierda.

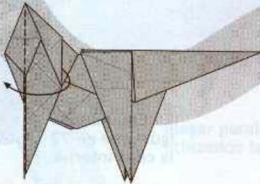

58. Plegar hacia la izquierda.

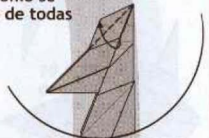

55. Liberar el papel en blanco.

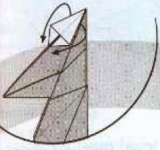

56. Crear pétalo.

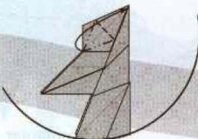

57. Plegar Hacia abajo.

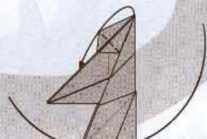

67. Hacer  
Hundido  
abierto.  
(open sink)

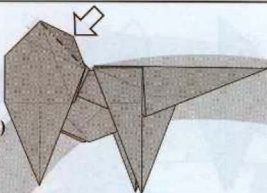

68. Plegar hacia la  
derecha y repetir  
60-68 atras.



66. Plegar y desplegar  
uniendo los extremos.

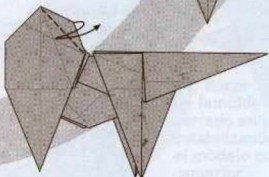

69. Abrir la  
parte baja.



70. Plegar  
y desplegar.



71. Plegar  
y desplegar  
paralelo al borde utilizando  
la referencia ○

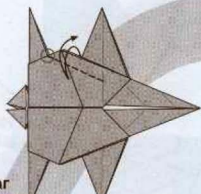

75. Ensamblar  
igual que en 72  
la capa interna.

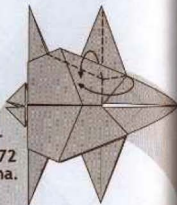

72. Ensamblar  
como se indica.

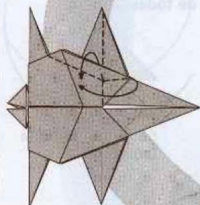

73. Vista  
72. Desplegar.

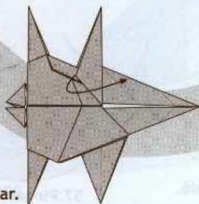

74. Ensamblar al igual que  
en 72, pero solo la capa  
mas externa.

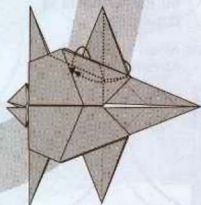

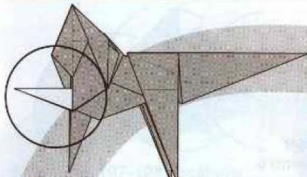

83. Acercamiento.  
(Zoom in)



84. Plegar hacia dentro y fuera como se indica.

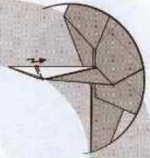

85. Escalonar.

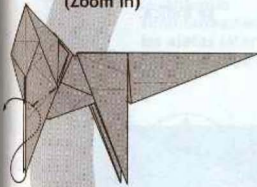

82. Plegar hacia dentro y fuera.

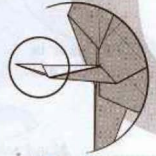

86. Acercamiento (zoom in)

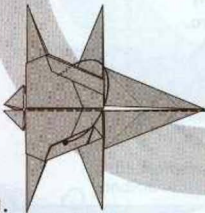

81. Cerrar el modelo introduciendo la aleta formada en 80 dentro del bolsillo.

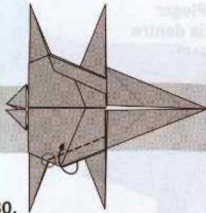

80. Plegar paralelo al lado utilizando la referencia

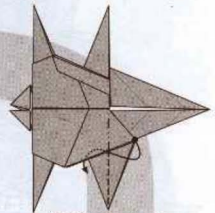

79. Plegar hacia dentro y fuera.

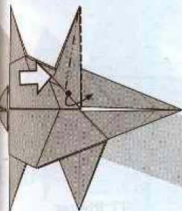

76. Mover la capa hacia la derecha aplastando para no alterar los demás pliegues.

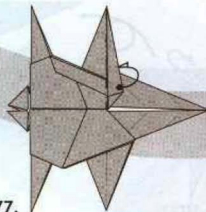

77. Plegar hacia atras.

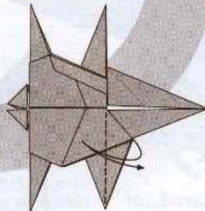

78. Plegar y desplegar.

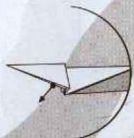

87. Liberar la primera capa.

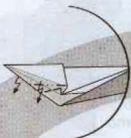

88. Escalonar simétrico.



89. Plegar hacia dentro. Fin acercamiento. (Zoom out)



90. Moldear como se indica.

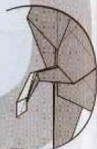

91. Fin acercamiento. (Zoom out)

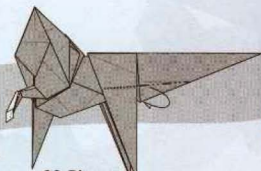

92. Plegar hacia dentro.

93. Plegar hacia dentro y fuera.

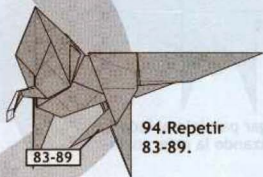

94. Repetir 83-89.

83-89



95. Moldear como se indica.



96. Plegar hacia atrás. Voltear modelo.

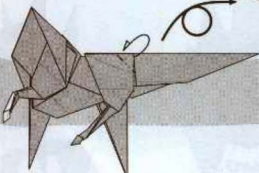

97. Plegar hacia dentro.

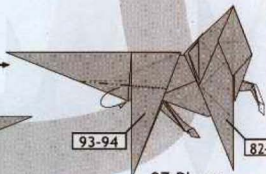

93-94

82-89





107-108. Escalonar arriba hacia atras, levantando simultaneamente las aletas laterales. Extrar la capa interna.

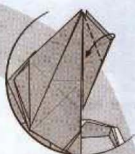

109. Doblar el ángulo bisector.

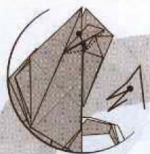

111. Extraer la capa interna y doblarla por sus líneas existentes.

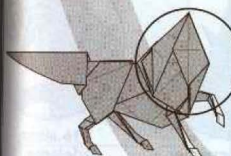

106. Acercamiento. (Zoom in)



110. Doblar hacia adelante.

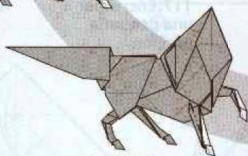

105. Moldear como se indica.

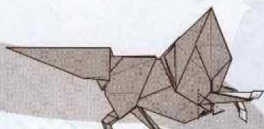

104. Escalonar hacia atras.

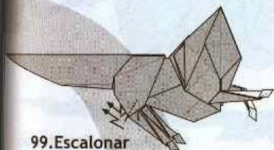

99. Escalonar hacia atras.

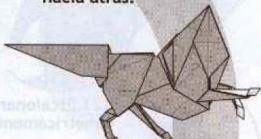

103. Vista 102.

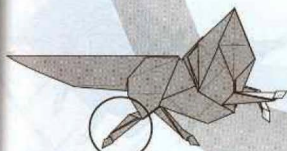

100. Acercamiento. (Zoom in)



101. Escalonar simétricamente como se indica. Fin acercamiento. (Zoom out)

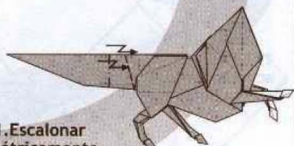

102. Escalonar.

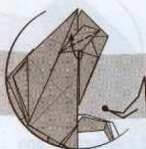

112. Plegar hacia arriba.

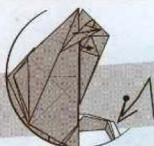

113. Plegar hacia dentro y fuera.

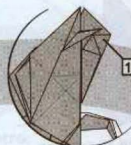

114. Repetir 109-113 atras.



115. Abrir y levantar.



119. Moldear como se indica.

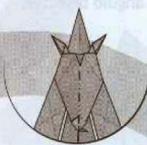

118. Crear una pequeña cavidad.

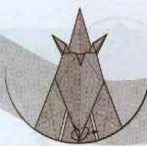

117. Encrespar una pequeña porción.

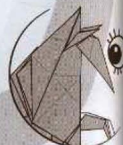

116. Mirar adelante.



120. Plegar hacia dentro y fuera.



121. Escalonar simetricamente.



122. Fin acercamiento (Zoom out)

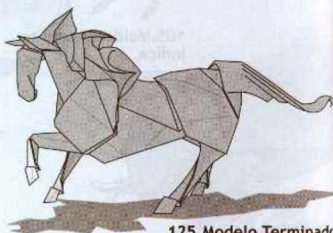

125. Modelo Terminado.

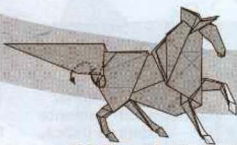

123. Plegar hacia dentro y fuera adelante y atras.

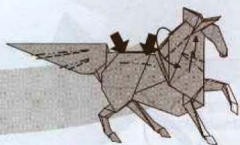

124. Escalonar en el frente. Moldear como se indica.

# Mammoth

Model & diagram © Pavel Nikulshin

Paper : Bicolor

Size of square : 70 cm

Density of paper : 60g/m<sup>2</sup>

Email npvru@mail.ru

If you wish to receive good result, I recommend to you to fold this model two times that is better for to feel.



1.

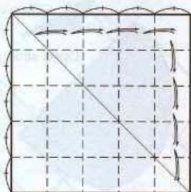

2.

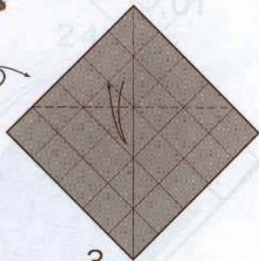

3.

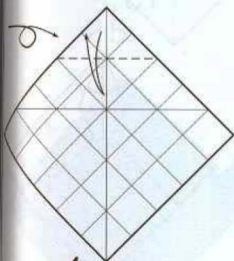

4.

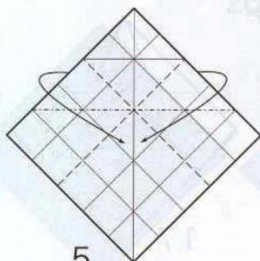

5.

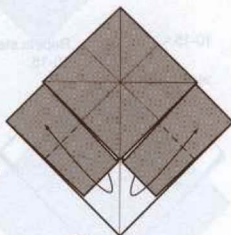

6.

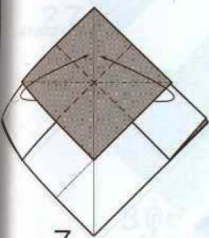

7.

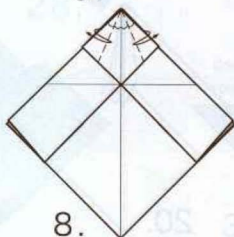

8.

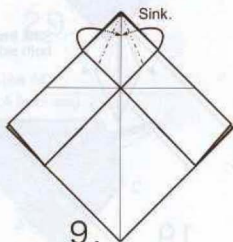

9.



マンモス/バヴェル・ニクルシ (ロシア)

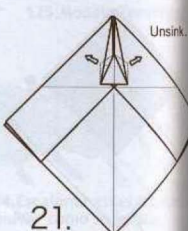
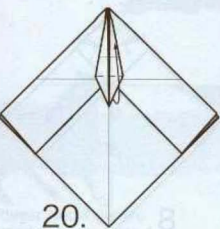
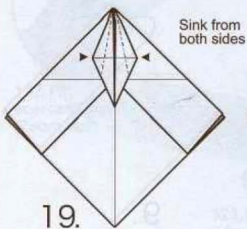
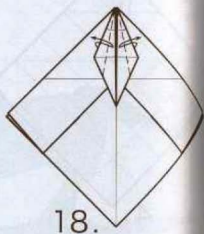
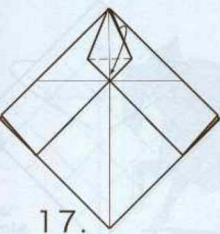
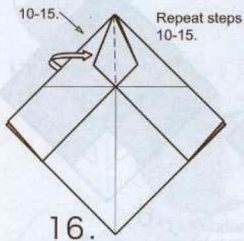
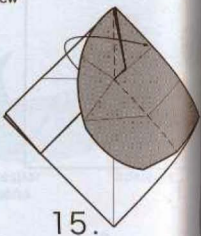
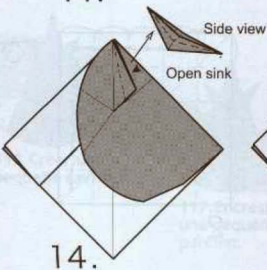
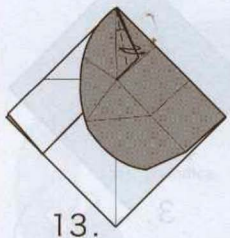
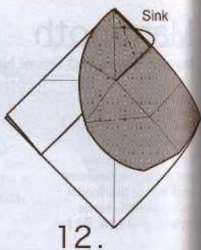
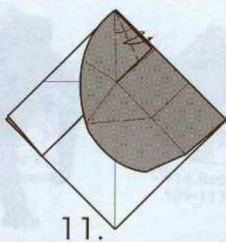
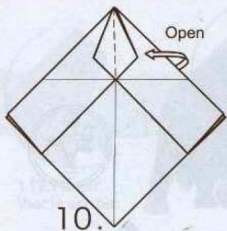



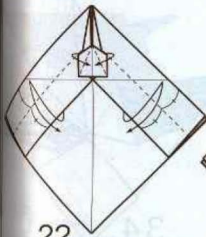

22.

Fold and unfold one layer.

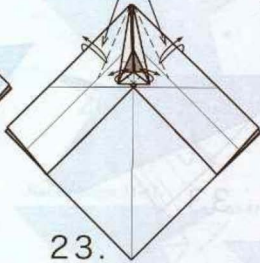

23.

Fold and unfold one layer.

Sink corners.

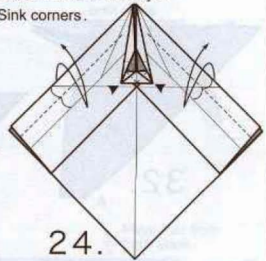

24.

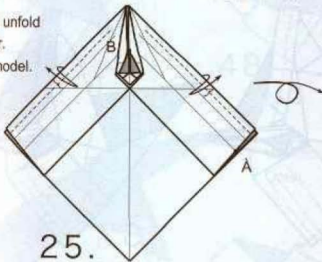
Fold and unfold  
the layer.  
Rotate model.

25.



26.

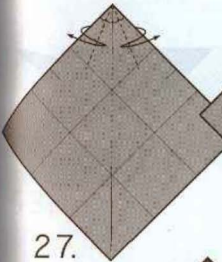

27.

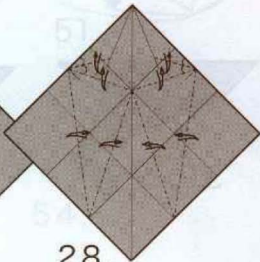

28.

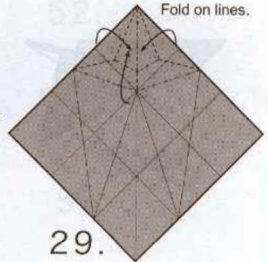

29.

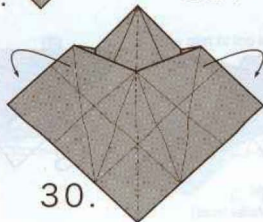

30.

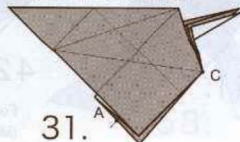
Create line AC  
(point A from step 25).

31.

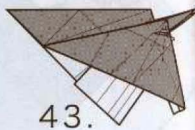
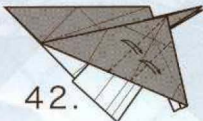
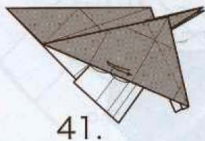
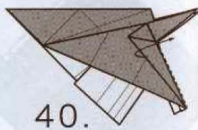
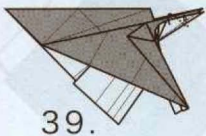
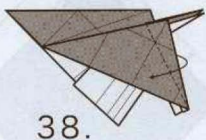
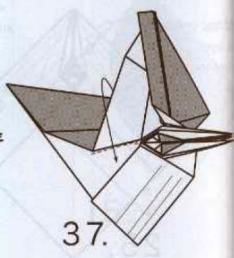
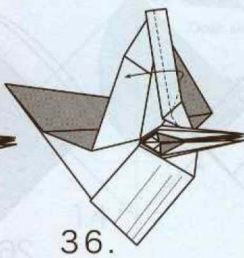
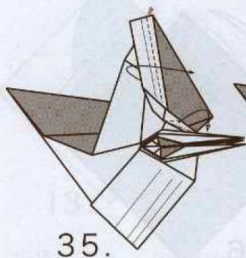
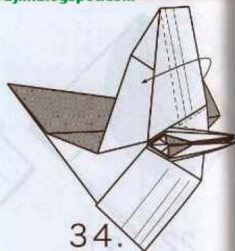
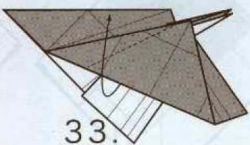
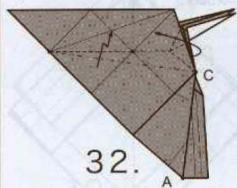

Fold and unfold  
(Make two parallel lines)

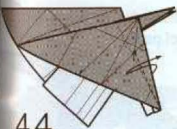

44.

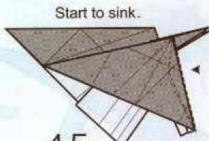

45.

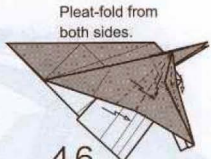

46.

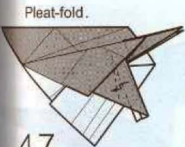

47.

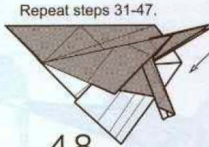

48.

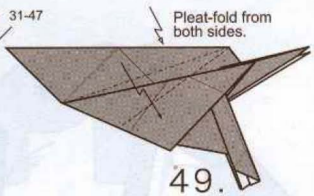

49.

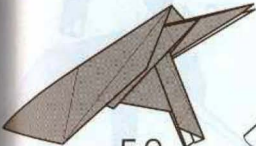

50.

View from other side  
Open.

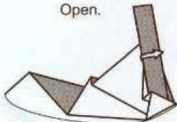

51.

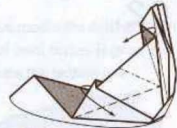

52.

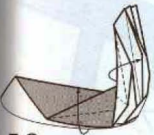

53.

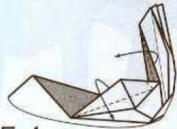

54.

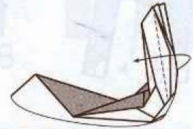

55.



56.

The part of top layer not show.  
Pleat-fold.



57.

Unsink.

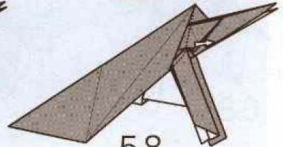

58.

Repeat steps 51-58.

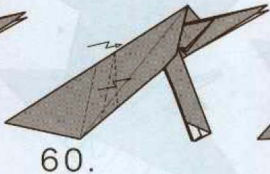
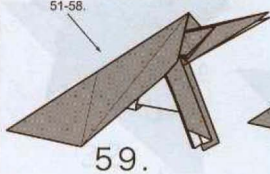

Pleat-fold all layers of paper

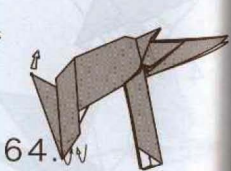
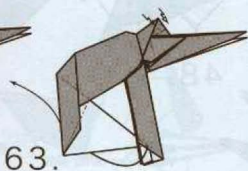
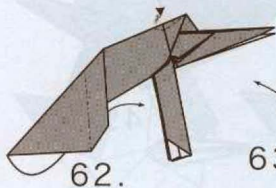
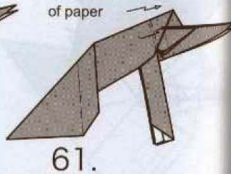

To pull from point.

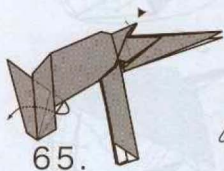

Steps 67-76 to do simultaneously from both sides.

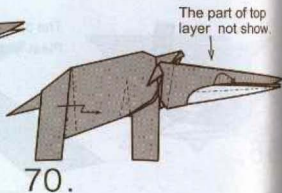
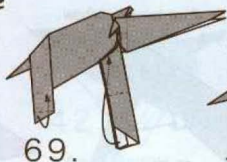
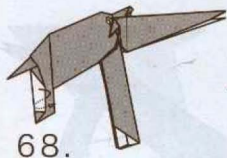
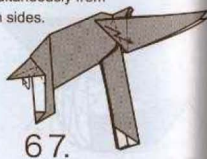



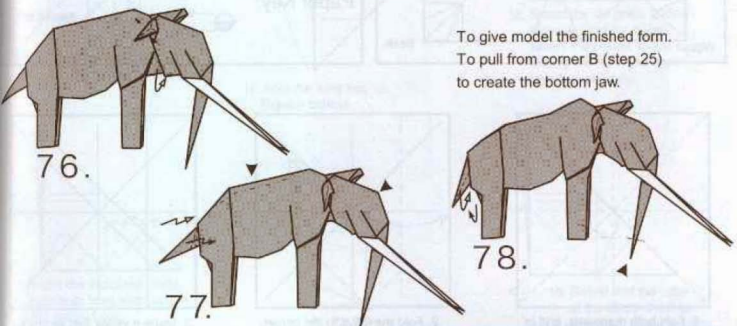
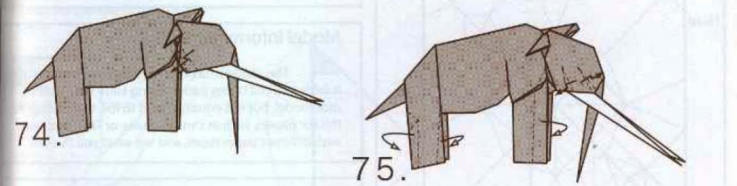
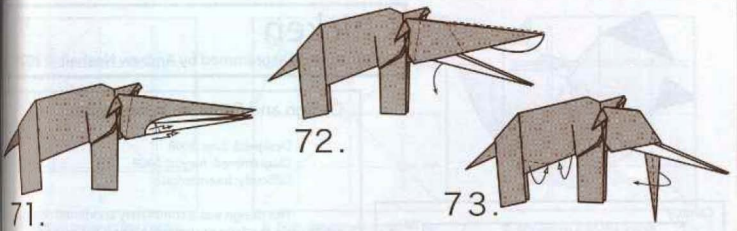

To give model the finished form.  
To pull from corner B (step 25)  
to create the bottom jaw.

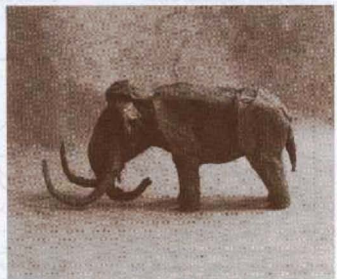
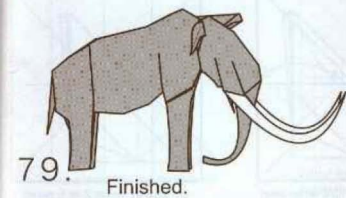

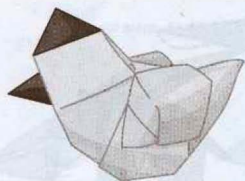

## Chicken

Designed and Diagrammed by Andrew Neehall, © 2009

### Design and Diagram Information:

Designed: June 2008  
 Diagrammed: August 2009  
 Difficulty: Intermediate

This design was a completely accidental discovery made while teaching my parents some basic origami.

### Model information:

This chicken has very humble paper requirements: it folds well out of any paper. Using kami will result in a nice model, but it is equally suited to foil, wet folding, and thicker papers, such as canson paper, or Tant. Just play with different paper types, and see what you like best.

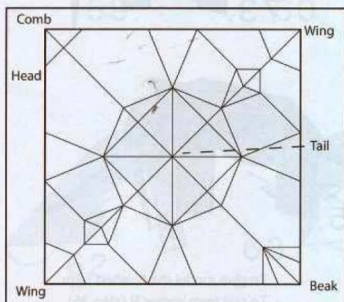

### Paper Key:

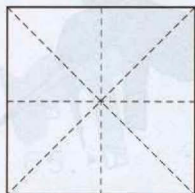
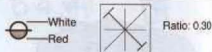

1. Fold both diagonals, and in half both ways.

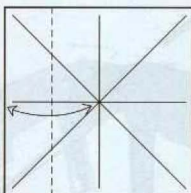

2. Fold the edge to the center. Unfold.

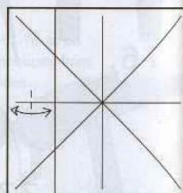

3. Make a valley fold as shown, pinching only in the center.

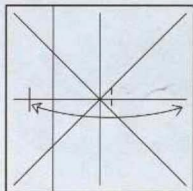

4. Fold the left edge over to the pinch made in step 3.

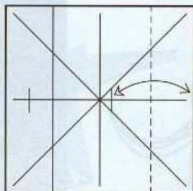

5. Valley fold the right edge over to the pinch made in step 4.

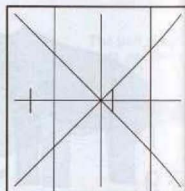

6. Repeat steps 2 to 5 on all 3 remaining sides.

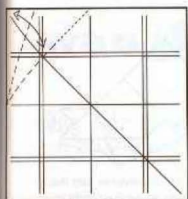

7. Fold the corner to the center, pinching only the left side. Bisect the triangle formed by this pinch.

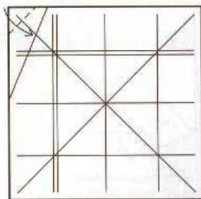

8. Fold the corner down to the bisection made in step 7.

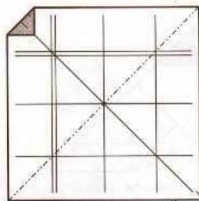

9. Mountain fold the lower flap behind.

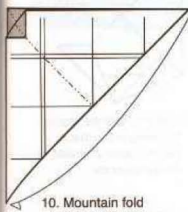

10. Mountain fold the model in half.

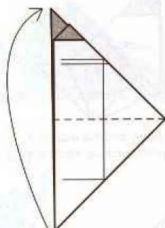

11. Fold the front flap up. Repeat behind.

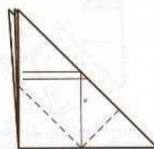

12. Bisect the tail point, folding through all of the layers. Bisect the breast, in this case folding the front and back layers separately.

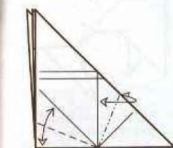

13. Bisect the indicated chest flaps both front and back with valley folds. Bisect the indicated part of the tail with a mountain fold. Unfold.

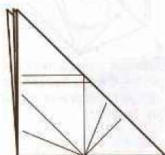

14. Like this.

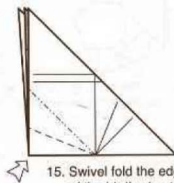

15. Swivel fold the edge of the bird's chest as indicated, along existing creases. Don't repeat behind just yet!

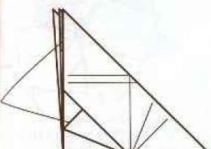

16. The exclamation mark indicate the raw edges.

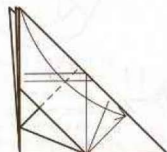

17. Valley fold the wing down, lining the trailing edge up with the bird's back.

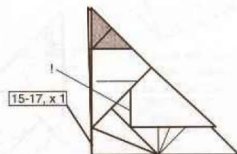

18. Note the raw edge exposed by step 17, denoted by the exclamation mark. Repeat steps 15-17 on the other side.

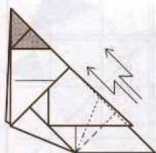

19. Crimp the tail in on the indicated folds.

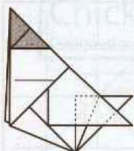

20. Note the arrangement of the inner layers.

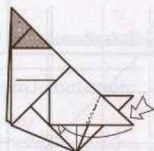

21. Inside reverse fold the wing tips to be flush with the tail. Don't repeat behind yet.

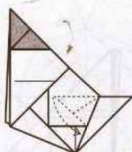

22. Bisect the hidden layers in the wing with a valley fold.

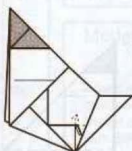

23. Valley fold the exposed point back up into the wing.

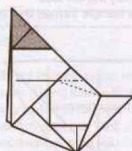

24. Reverse fold the top of the wing to narrow it, paying close attention to the references.

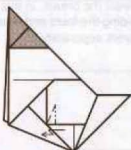

25. Crimp the wing, to round it and make it 3 dimensional.

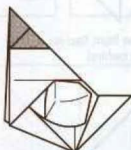

26. Lock the wing by mountain folding the tiny flap behind the wing which was created by the pleat.

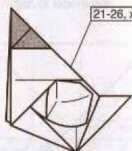

27. Repeat steps 21-26 on the opposite side.

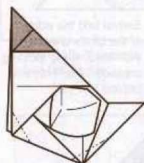

28. Shape the body with mountain folds. Repeat behind as well.

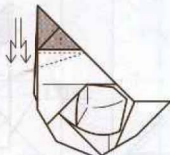

29. Crimp the beak downwards.

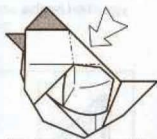

30. This is the result of step 29. Adjust as you like to get the expression you want. Push the back in on the indicated creases; the model will not remain flat, but will curve slightly on both sides.

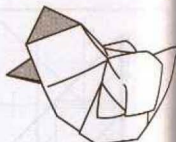

31. The finished chicken.



# Swan / Thiên nga

Hoàng Tiến Quyết  
March 2009 - June 2010

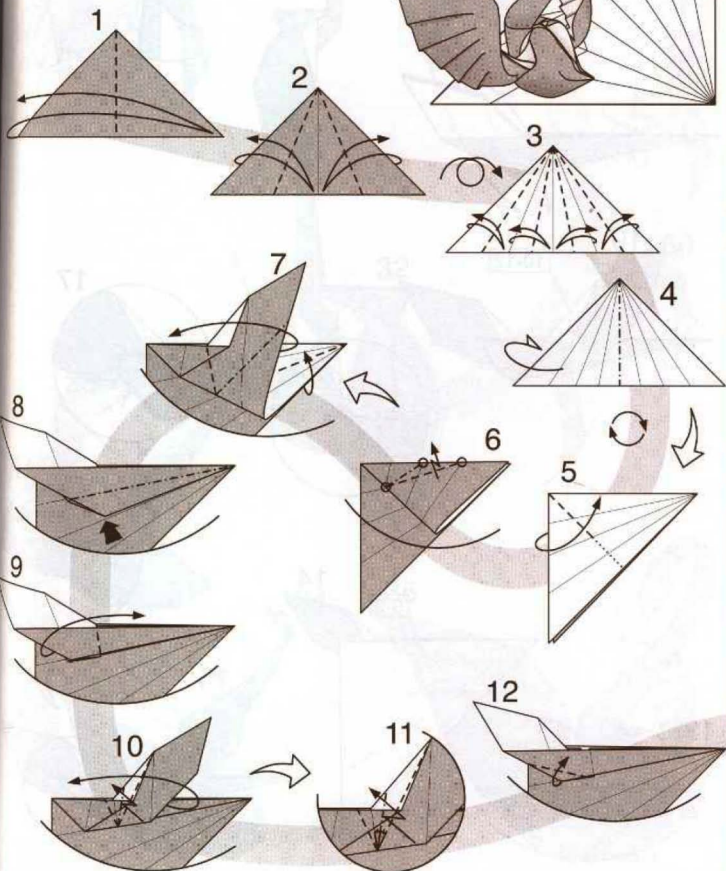
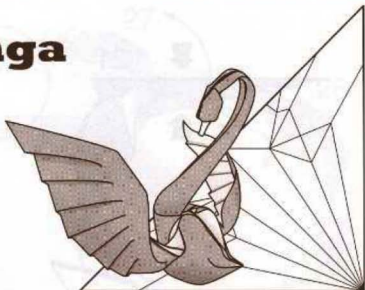

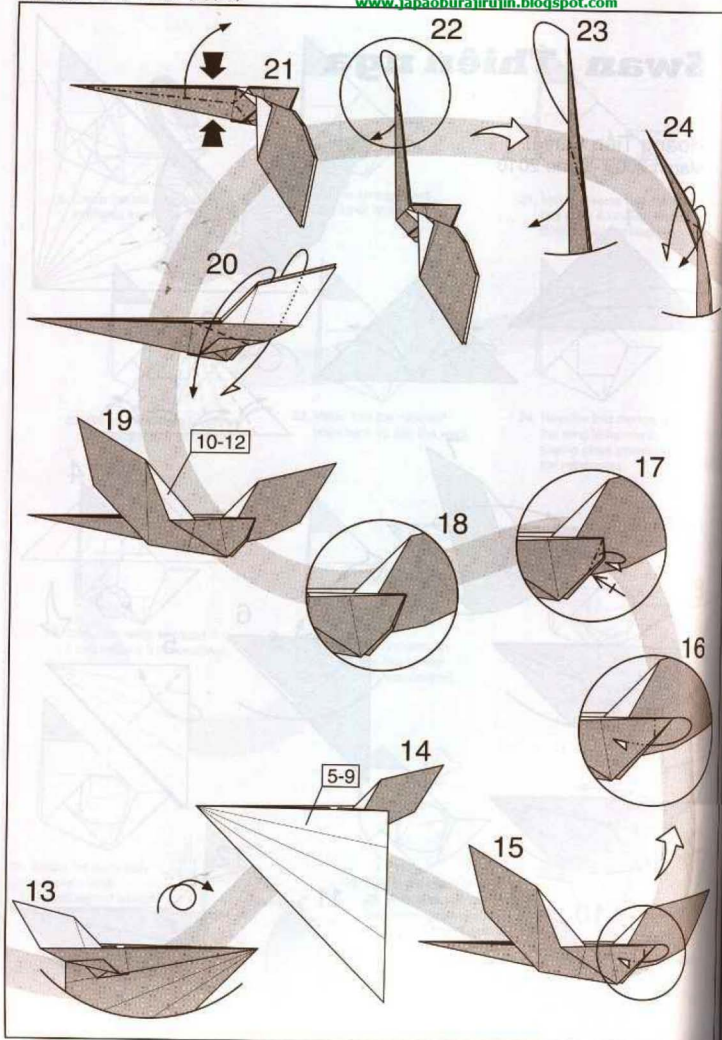

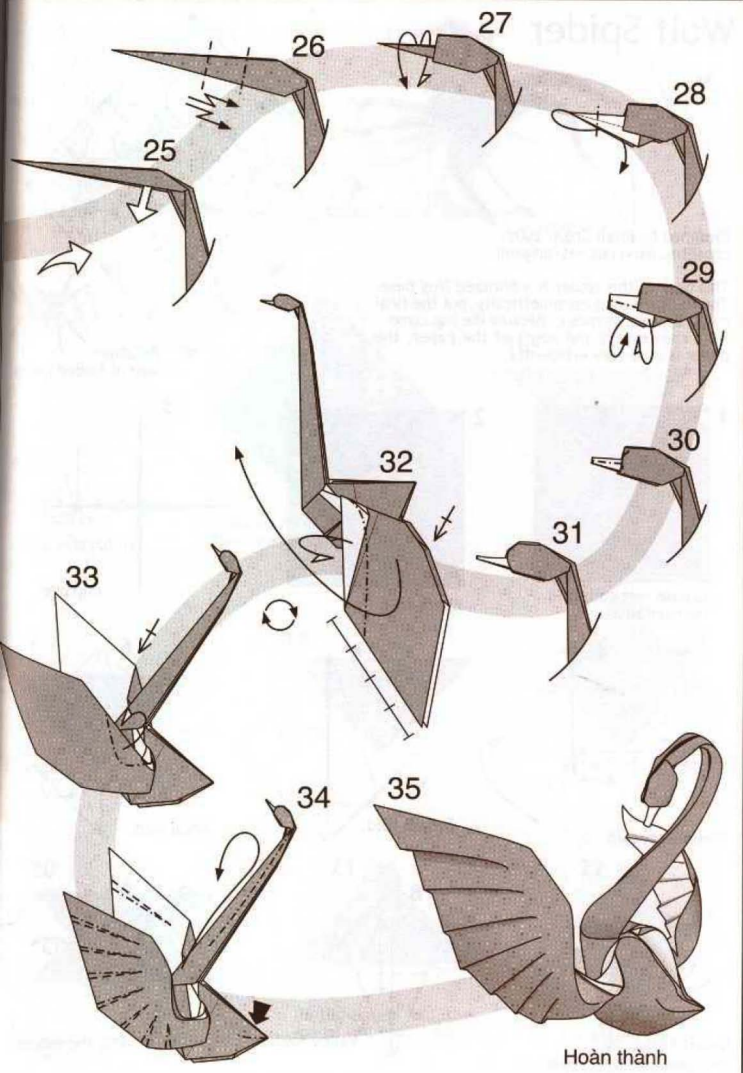

Hoàn thành

## Wolf Spider

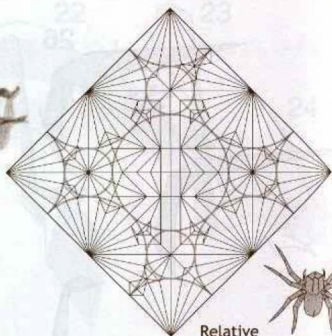
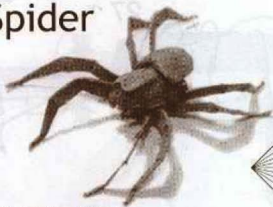

Relative size of folded model.

Designed by Brian Chan, 2009.  
chosetec.darkclan.net/origami

This base of this spider is a blintzed frog base. The flaps are used asymmetrically, but the final model appears symmetric. Because the legs come from the corners and edges of the paper, the paper is used very efficiently.

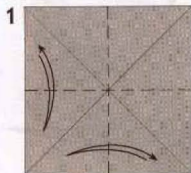

1 Crease vertically and horizontally.

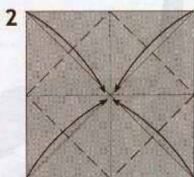

2 Blintz-fold.

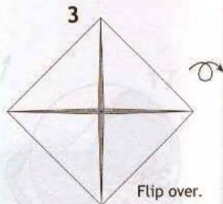

3 Flip over.

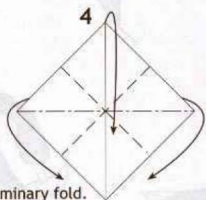

4 Preliminary fold.

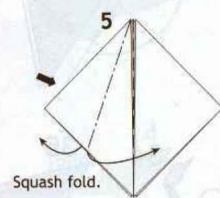

5 Squash fold.

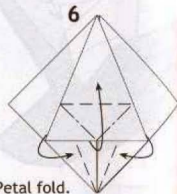

6 Petal fold.

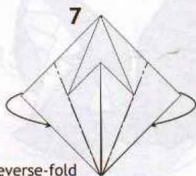

7 Reverse-fold the sides into the center.

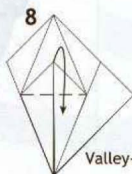

8 Valley-fold.

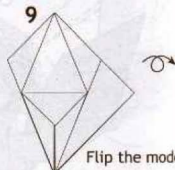

9 Flip the model.



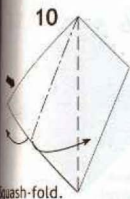

10

Squash-fold.



11

Petal-fold.

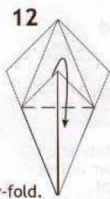

12

Valley-fold.

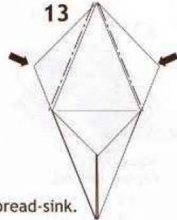

13

Spread-sink.

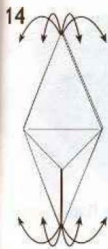

14

Unfold everything.

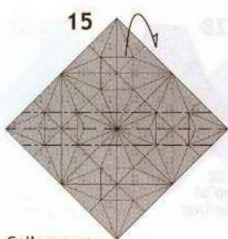

15

Collapse on the creases shown.

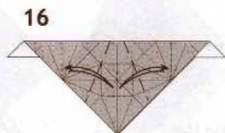

16

Precrease.

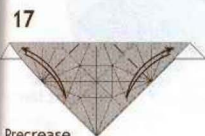

17

Precrease.

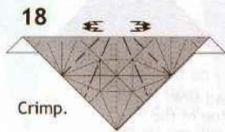

18

Crimp.

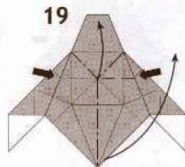

19

Petal-fold, repeat behind.

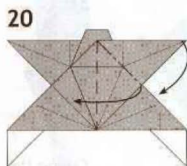

20

Squash-fold, repeat behind.

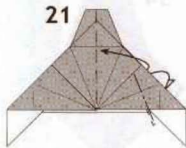

21

Partial squash fold, the model will not lie flat.

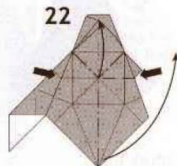

22

Petal-fold, repeat behind.

23

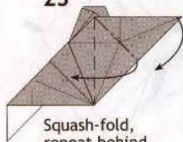

Squash-fold,  
repeat behind.

24

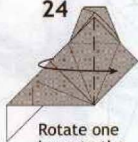

Rotate one  
layer to the  
right.

25

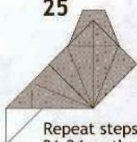

Repeat steps  
21-24 on the  
left.

26

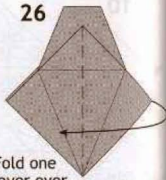

Fold one  
layer over.

27

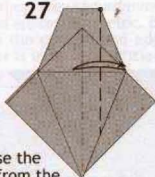

Crease the  
flap from the  
top corner.

28

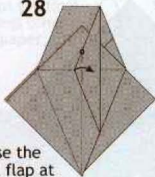

Crease the  
small flap at  
the centerline.

29

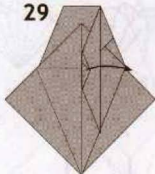

Unfold the flap.

30

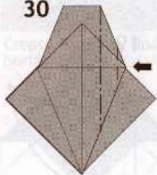

Open-sink in and out.

31

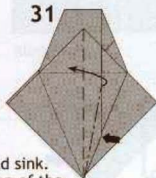

Spread sink.  
the top of the  
flap will not lie flat.

32

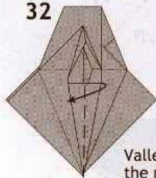

Valley-fold  
the next layer.

33

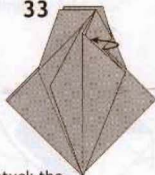

Untuck the  
small flap from behind.

34

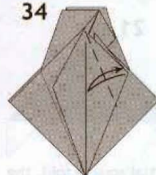

Crease the bisector.

35



Open-sink.

36



Crease the  
bisector.

37



Open-sink.

38

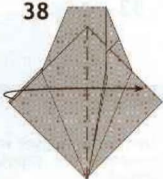

Valley-fold one flap.

39

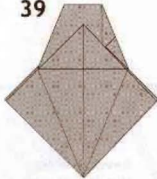

Repeat steps 26-38 three more times.

40

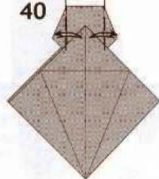

Crease along the vertical edge.

41

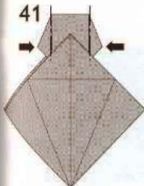

Open-sink.

42

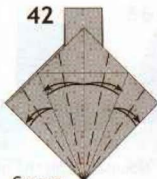

Crease the bisectors.

43

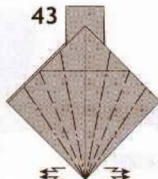

Crimp in and out.

44

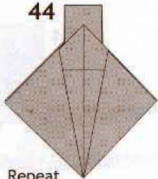

Repeat steps 42-43 on the sides and back.

45



Precrease the bisectors.

46



Open sink.

47



Repeat on the sides and back.

48



Fold one layer to the left.

49



Flip the model.



50



Fold one layer to the left. Note that this is not the mirror image of step 48.

51

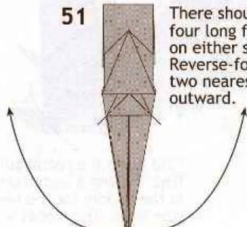

There should be four long flaps on either side. Reverse-fold the two nearest flaps outward.

52

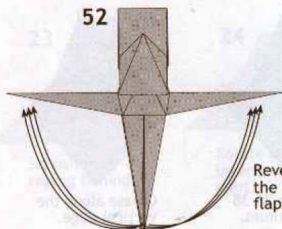

Reverse-fold the remaining flaps.

53

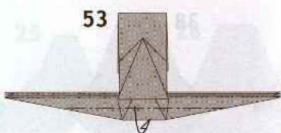

Thin the first layer with a mountain-fold, repeat behind.

54

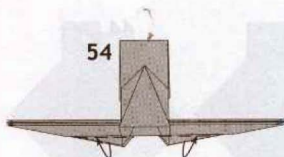

Valley-fold to thin the legs.

55

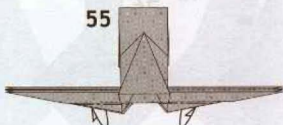

Mountain-fold the next layer.

56

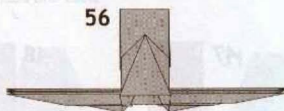

Thin the remaining legs.

57

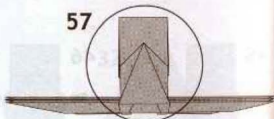

Detail of body.

58

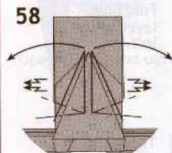

Pull out the two hidden flaps, using crimps.

59

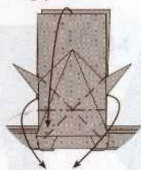

Fold down the rectangular flap, making a waterbomb in the middle for the two side flaps. The model will no longer lie flat.

60

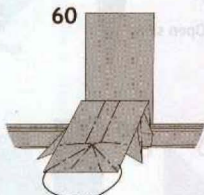

Shape the cephalothorax (head and thorax) on the creases shown.

61

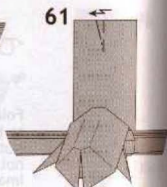

Pleat the tip of the abdomen to give it a 3D form.



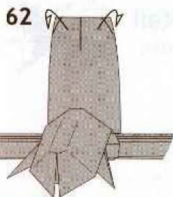

62 Round the corners of the abdomen.

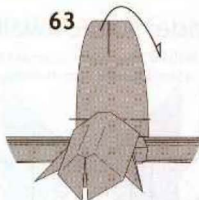

63 Mountain-fold the abdomen backward.

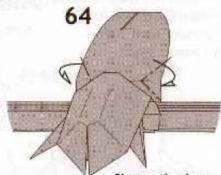

64 Shape the base of the abdomen.

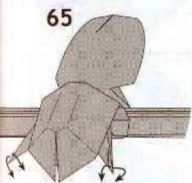

65 Pull out some paper to shape the palps (feelers).



66 Pleat the sides of the cephalothorax.

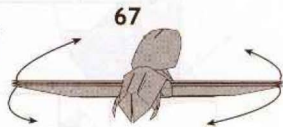

67 Spread the legs.

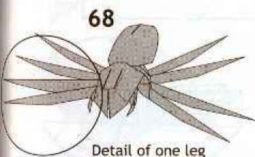

68 Detail of one leg



69 Crimp the base of the leg to angle it higher.

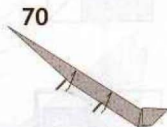

70 Bend the leg with crimps.



71 Shape the foot.

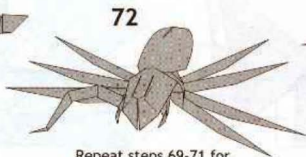

72 Repeat steps 69-71 for the remaining 7 legs.



Finished Wolf Spider.

Designed and diagramed by  
Michael G. LaFosse (USA)  
Copyright April, 2006  
Origamido, Inc.

# Alexander Aztec Swallowtail

Named for Richard Alexander, Origamido Studio (USA)  
15cm square = 11cm butterfly

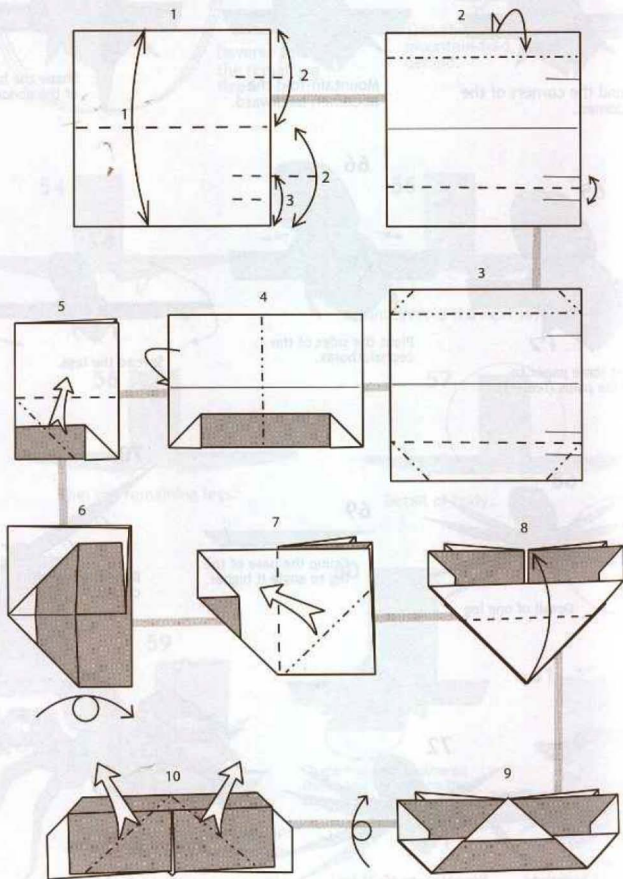

Michael G. LaFosse (USA)  
Copyright April, 2006  
Origamido, Inc.

# Alexander Aztec Swallowtail

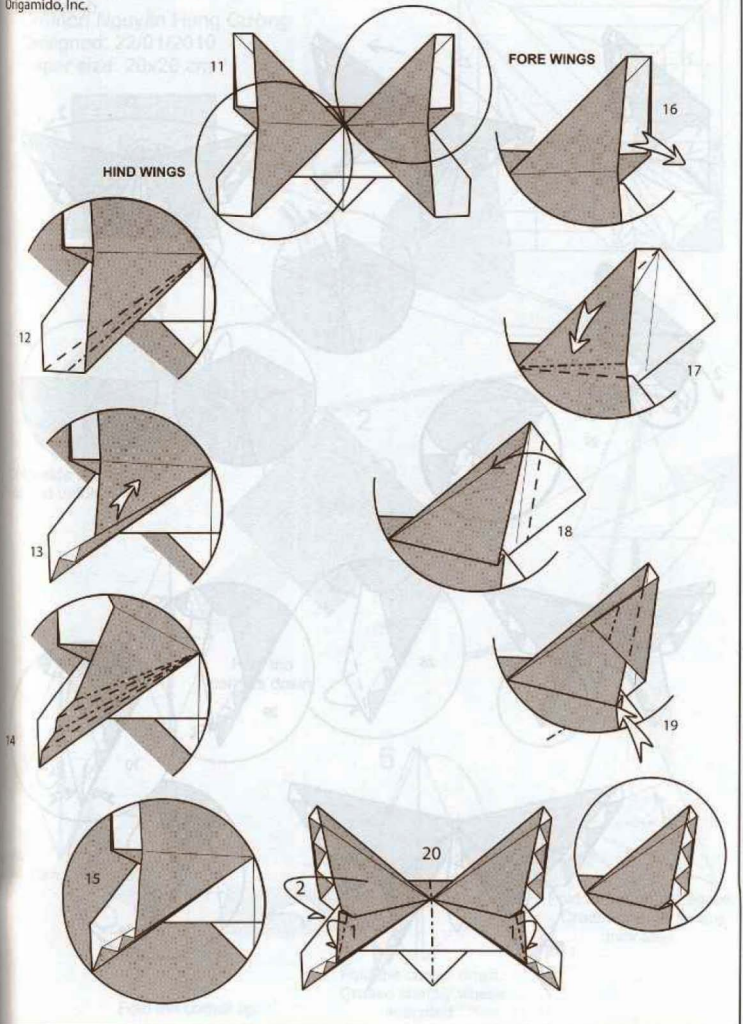

# Alexander Aztec Swallowtail

Michael G. LaFosse (USA)  
Copyright April, 2006  
Origamido, Inc.

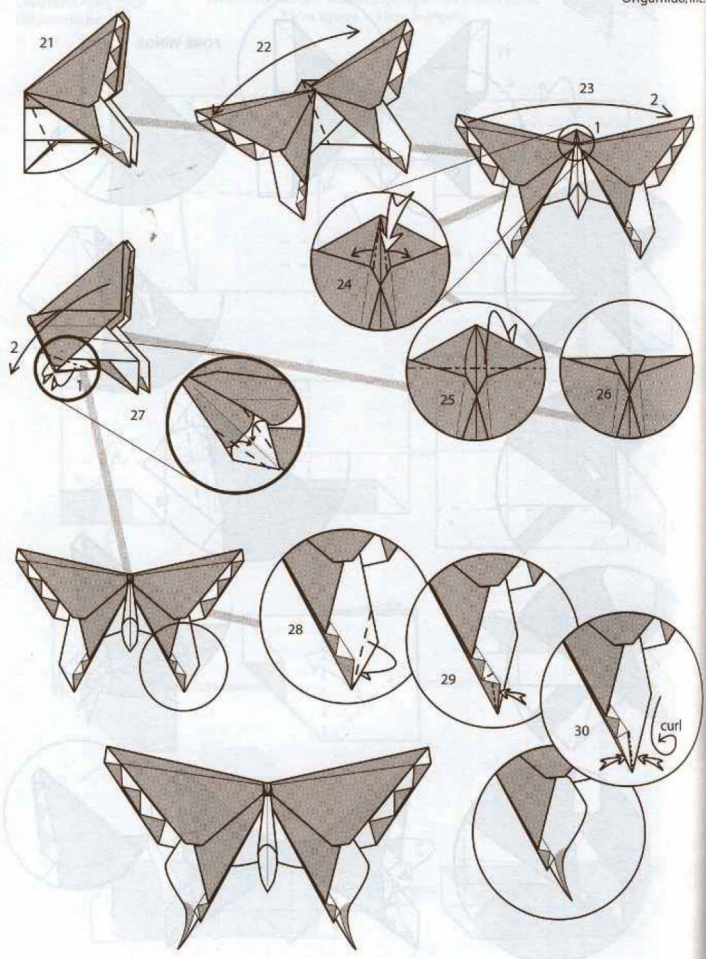



# SNAIL

Creator: Nguyễn Hùng Cường

Designed: 22/01/2010

Paper size: 20x20 cm

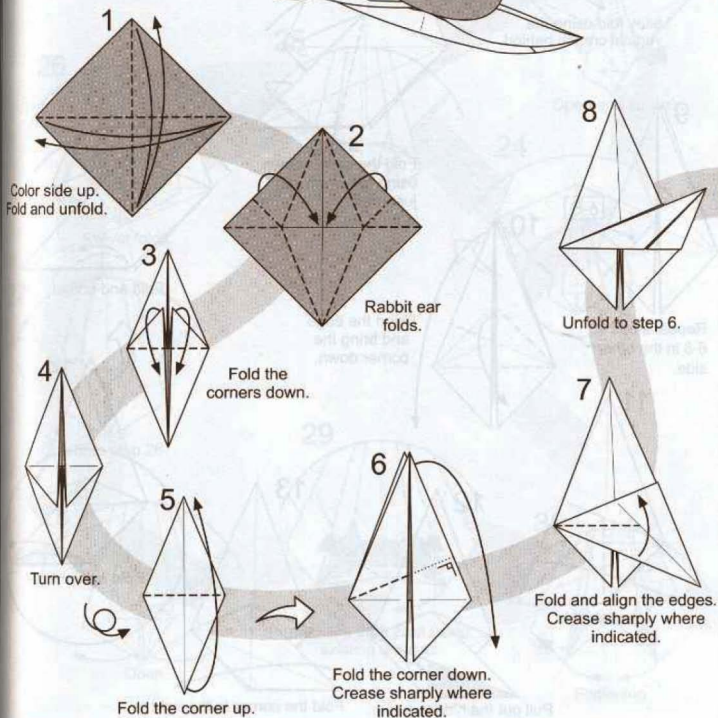
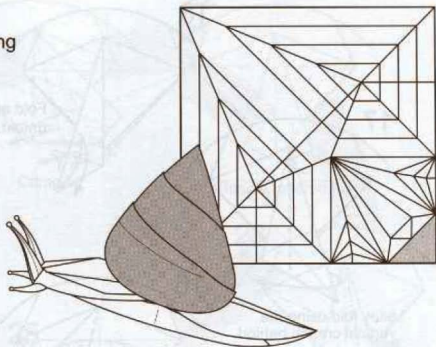

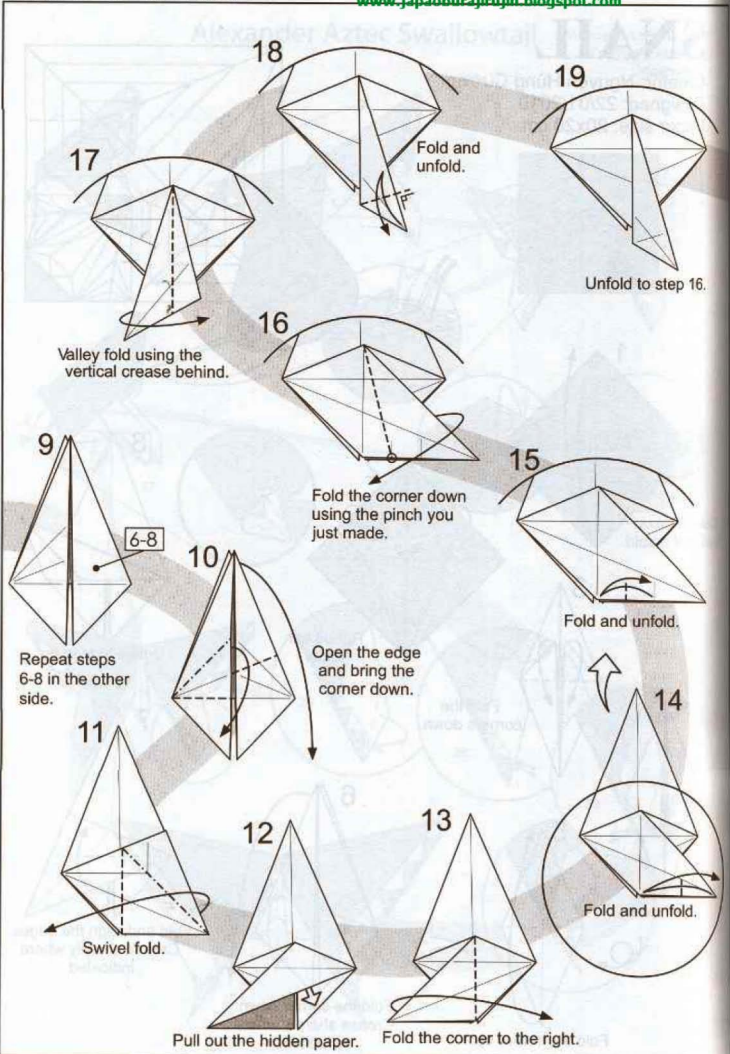

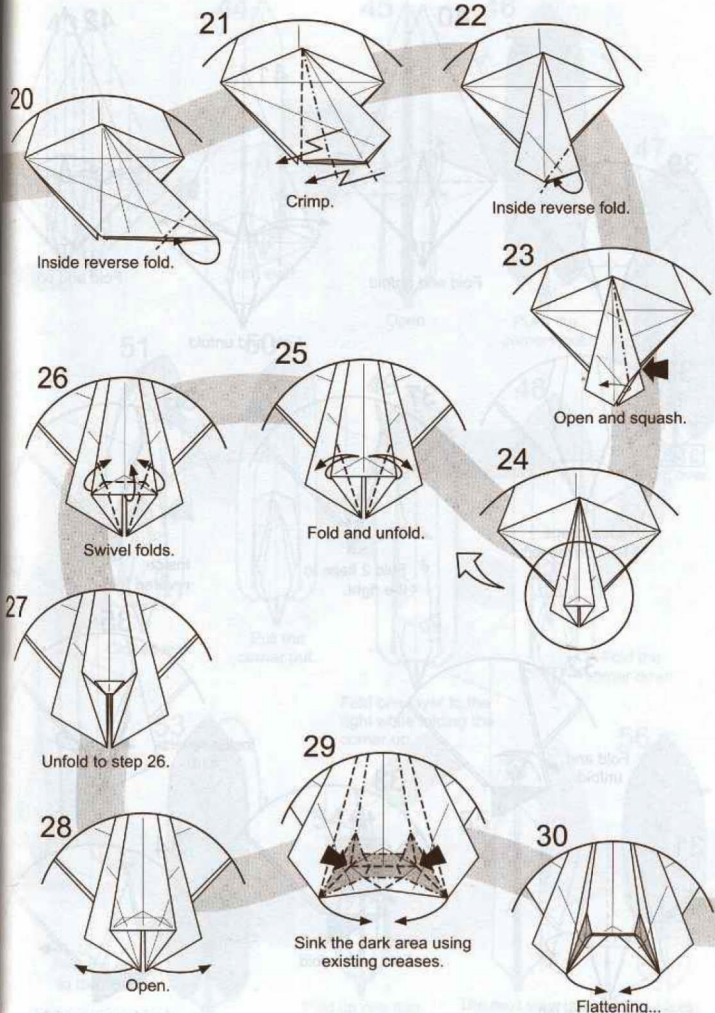

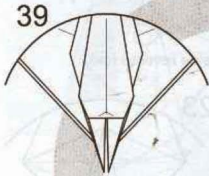

39

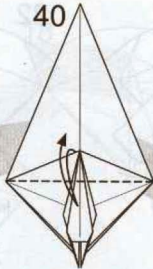

40

Fold and unfold.



41

Fold and unfold.

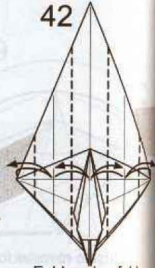

42

Fold and unfold.

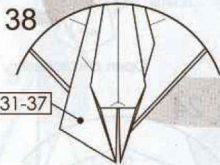

38

31-37

Repeat steps  
31-37 on the left.

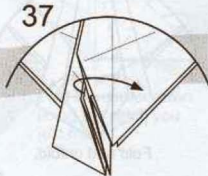

37

Fold 2 flaps to  
the right.

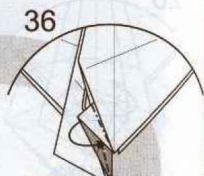

36

Inside  
reverse fold.

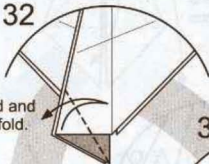

32

Fold and  
unfold.

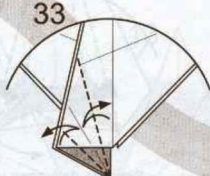

33

Fold and unfold.

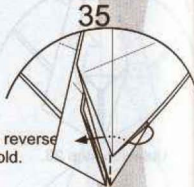

35

Inside reverse  
fold.

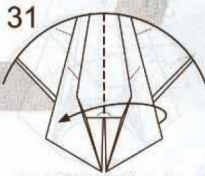

31

Fold 2 flaps to the left.

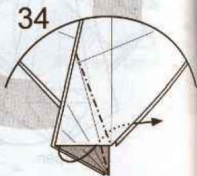

34

Inside reverse fold.



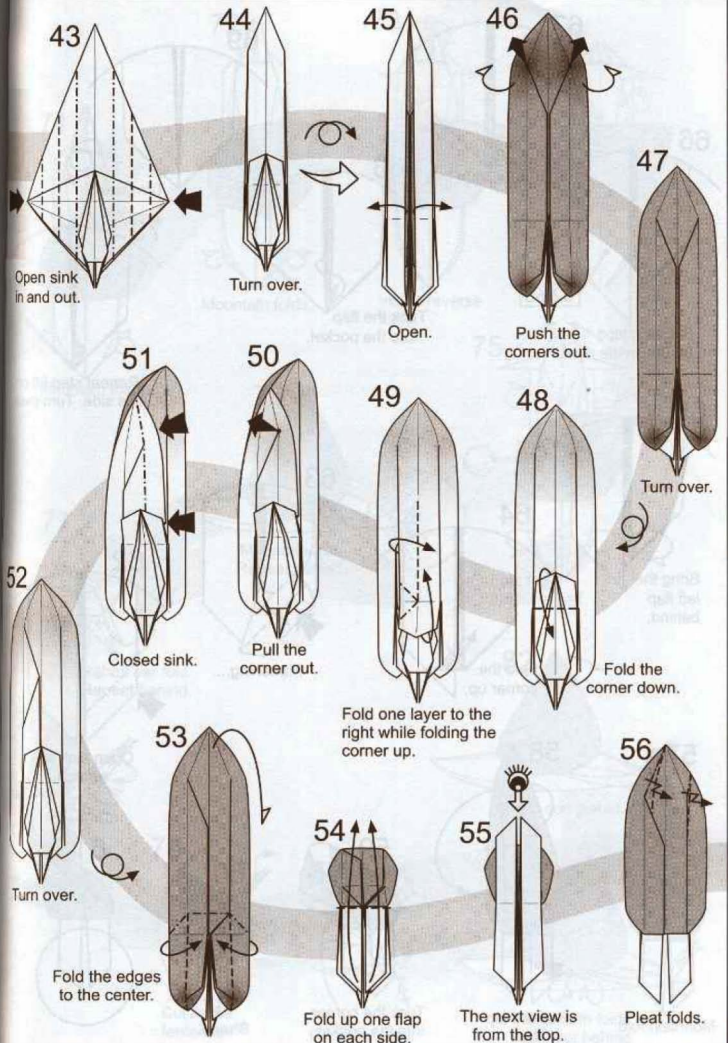

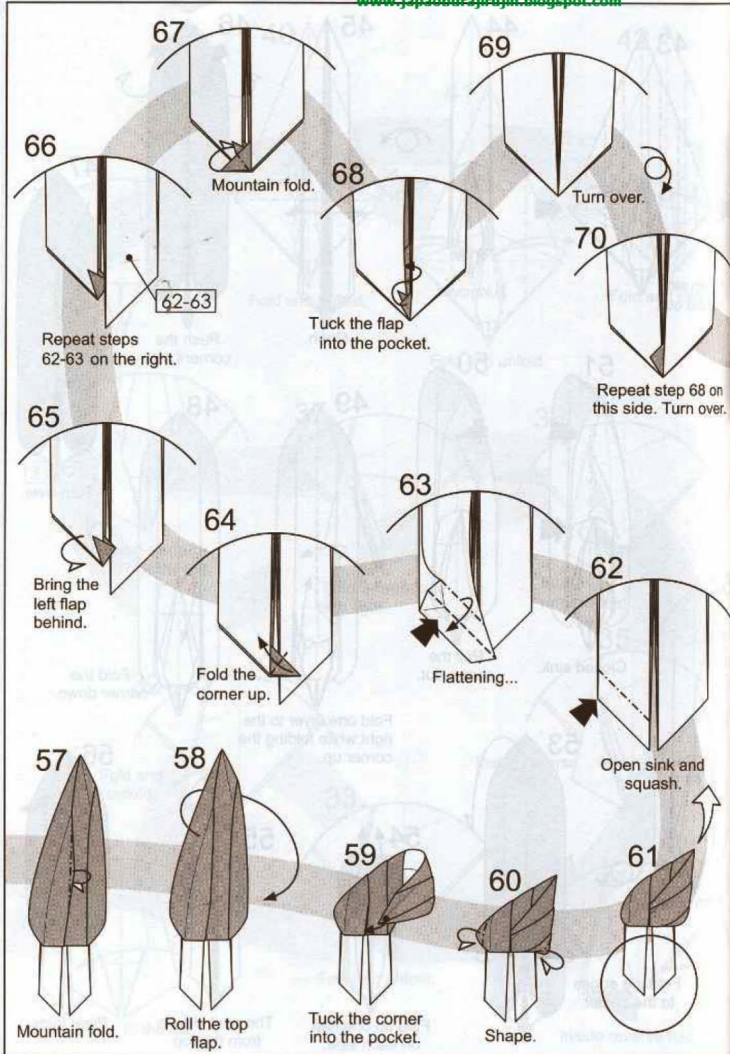

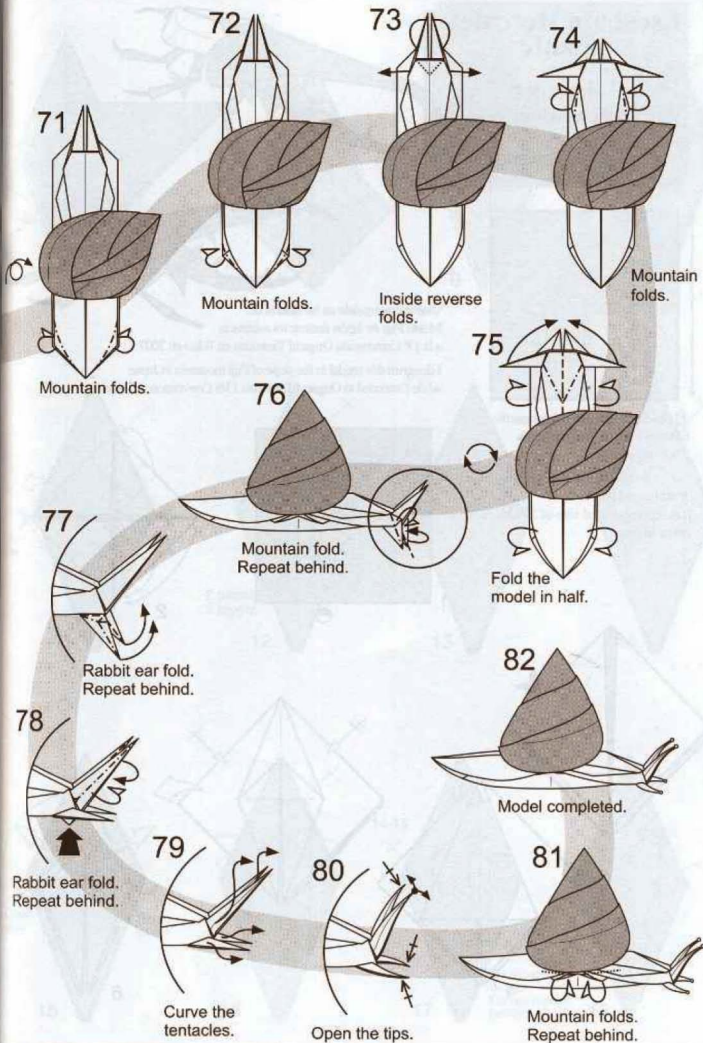

ヘラクレスオオカブト / マヌエル・シルゴ (スペイン)

# Escabajo Hercules gigante

## Hercules Giant Beetle

(c) M. Sirgo. 2007

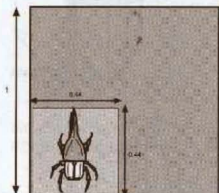
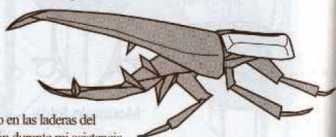
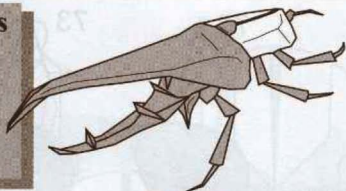

Diseñé este modelo en las laderas del Monte Fuji en Japón durante mi asistencia a la 13ª Convención Origami Tanteidan en Tokio en 2007

I designed this model in the slope of Fuji mountain in Japan while I attended to Origami Tanteidan 13th Convention in Tokyo.

El papel debe ser de bicolor, amarillo o blanco y negro. Se recomienda 25x25 cm o mayor.

Paper should be bicolor, yellow or white and black. It is recommended size of 25x25 cm or bigger.

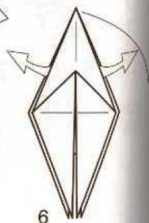
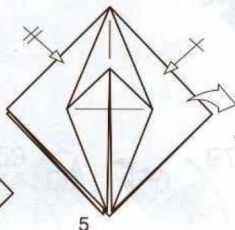
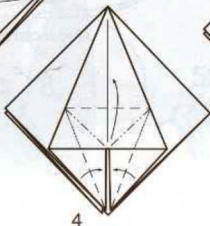
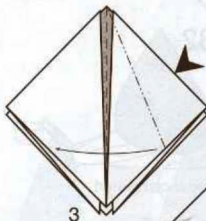
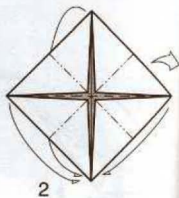
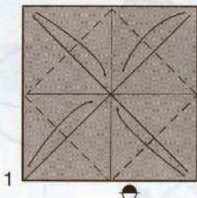



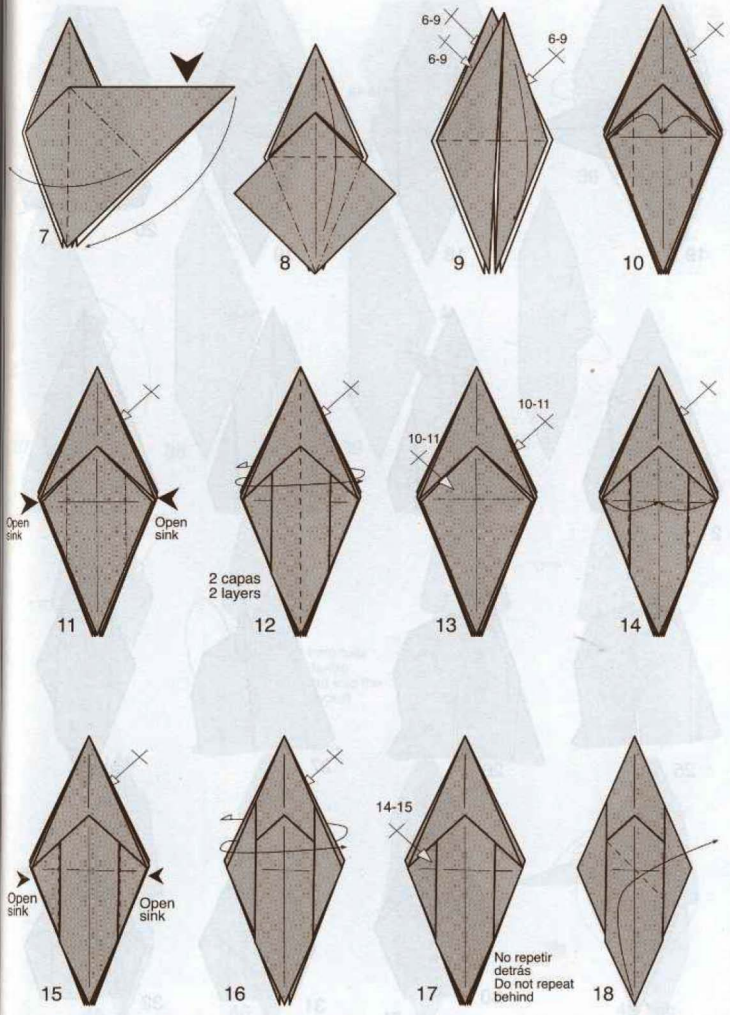

ヘラクレスオオカブト / マヌエル・シルゴ (スペイン)

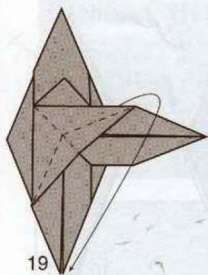

19

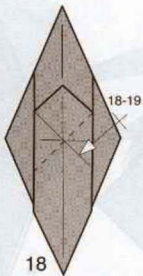

18

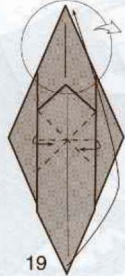

19

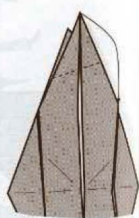

20

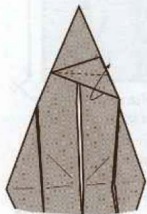

21



22

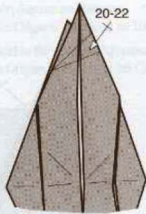

23

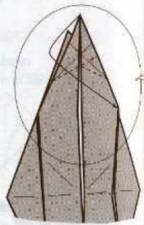

24

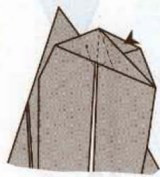

25



26

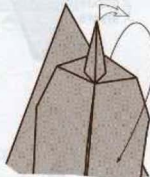

27

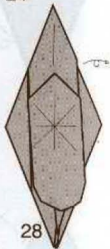

28

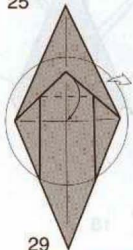

29

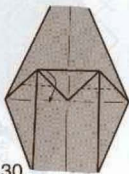

30

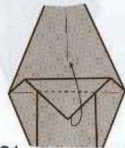

31

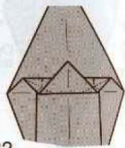

32

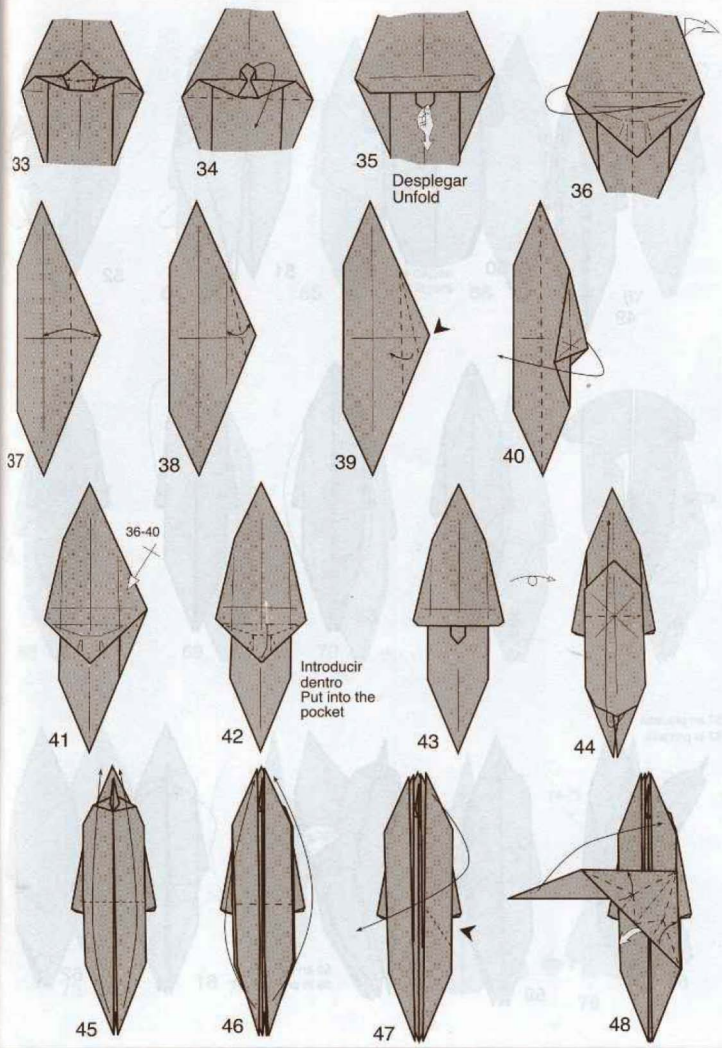

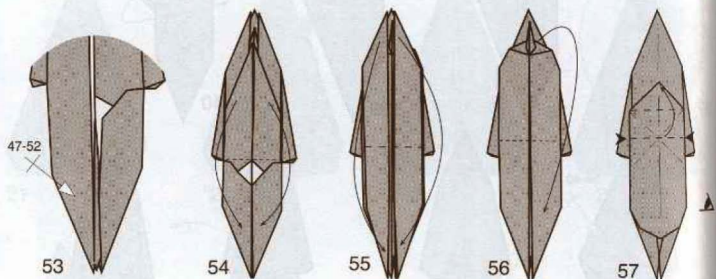
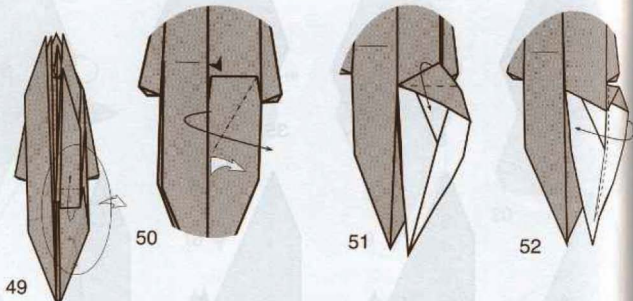

57 en proceso  
57 in process

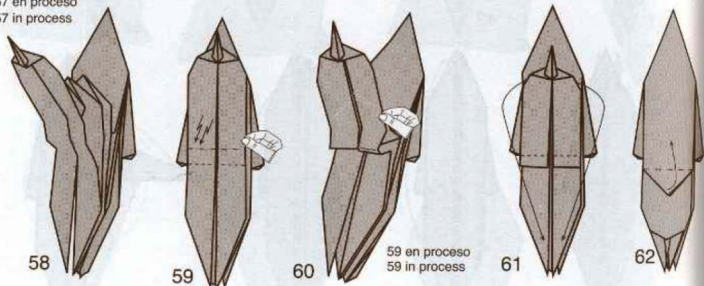



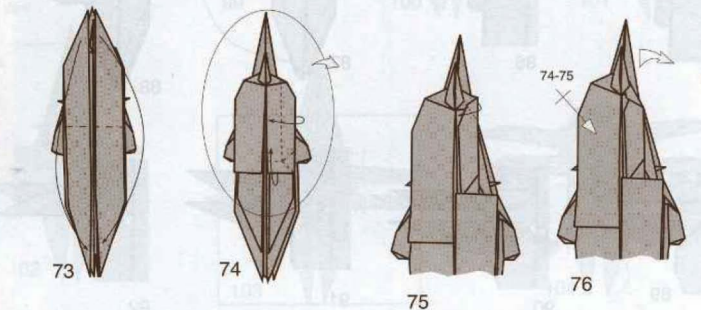
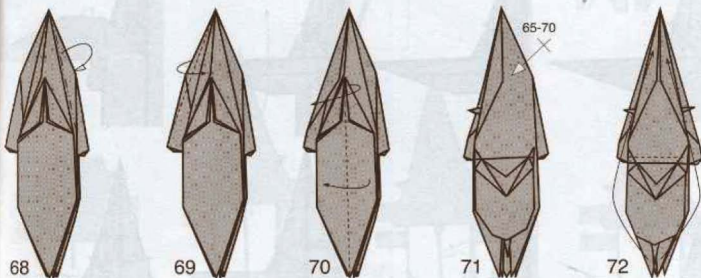
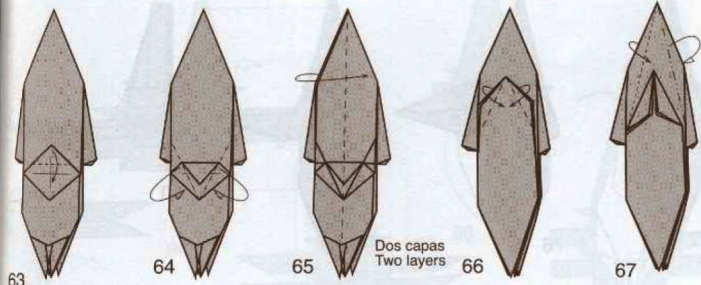

ヘラクレスオオカブト/マヌエル・シルゴ (スペイン)

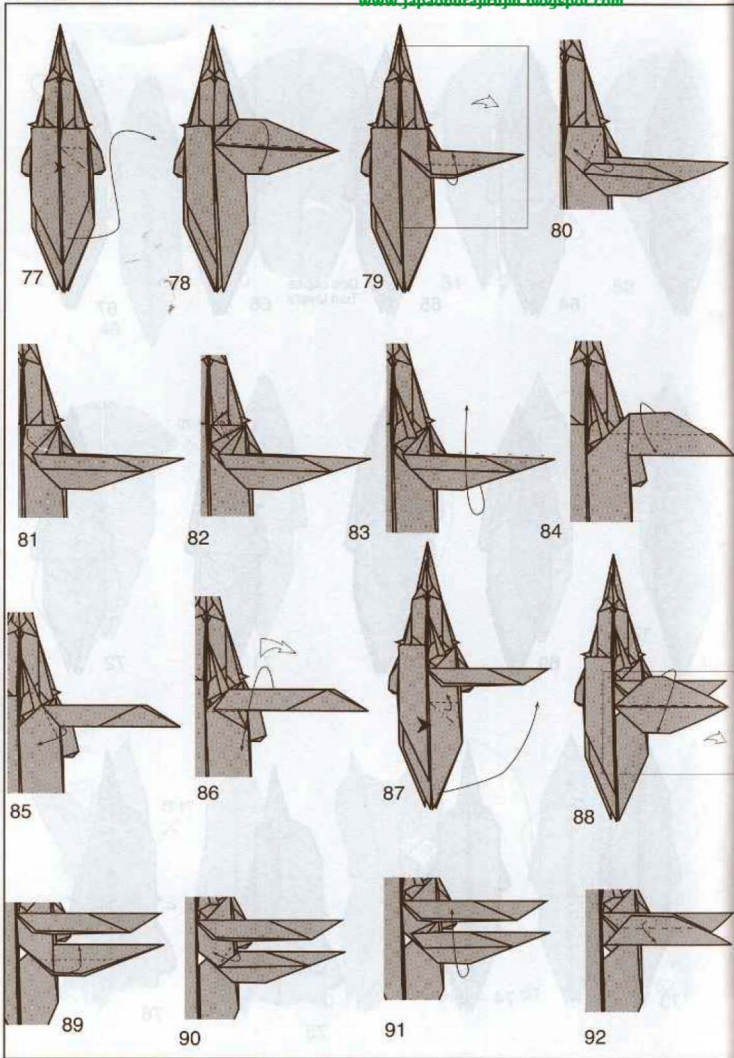

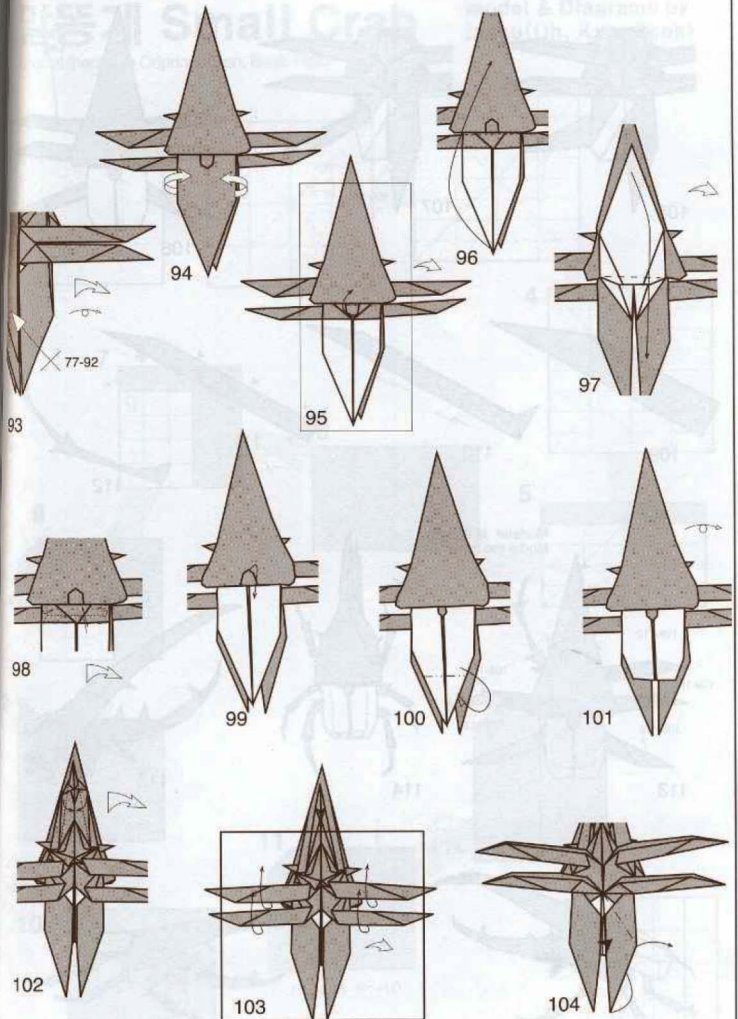

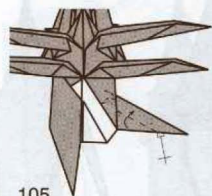

105

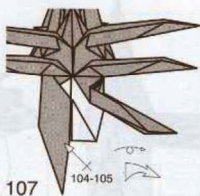

107

104-105

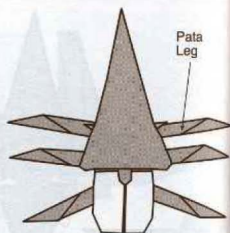

108

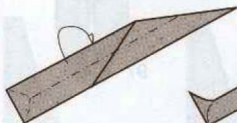

109

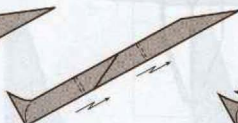

110

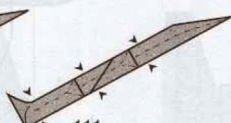

111

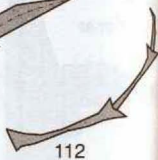

112

Modelar la cabeza  
Model the head

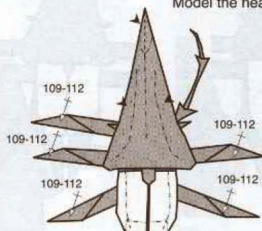

113

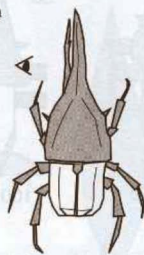

114

Detalle de la cabeza  
Detail of head



115

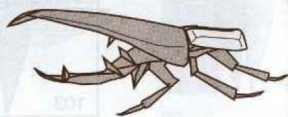
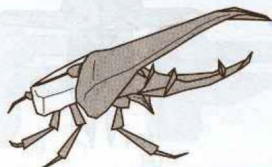



# 말똥게 Small Crab

model & Diagrams by  
jassu(Oh, Kyu-Seok)

2010. 5. 28.

Special thanks to Orinprince(Son, Baek-Rak)

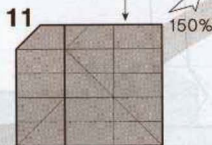
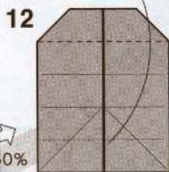
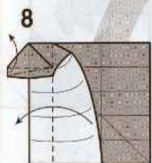
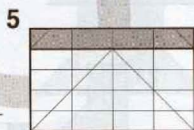
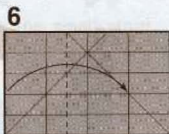
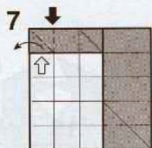
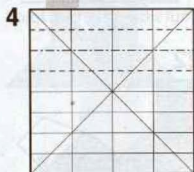
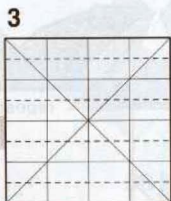
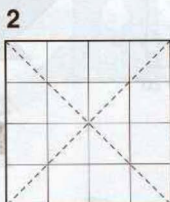

repeat 6~10

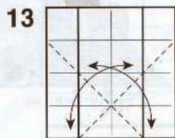

24

25

23

repeat 17~20

26

outside reverse fold

22

20

19

21

slide up

18

120%

15

(in action)

14

16

push the inner space

17

(in action)

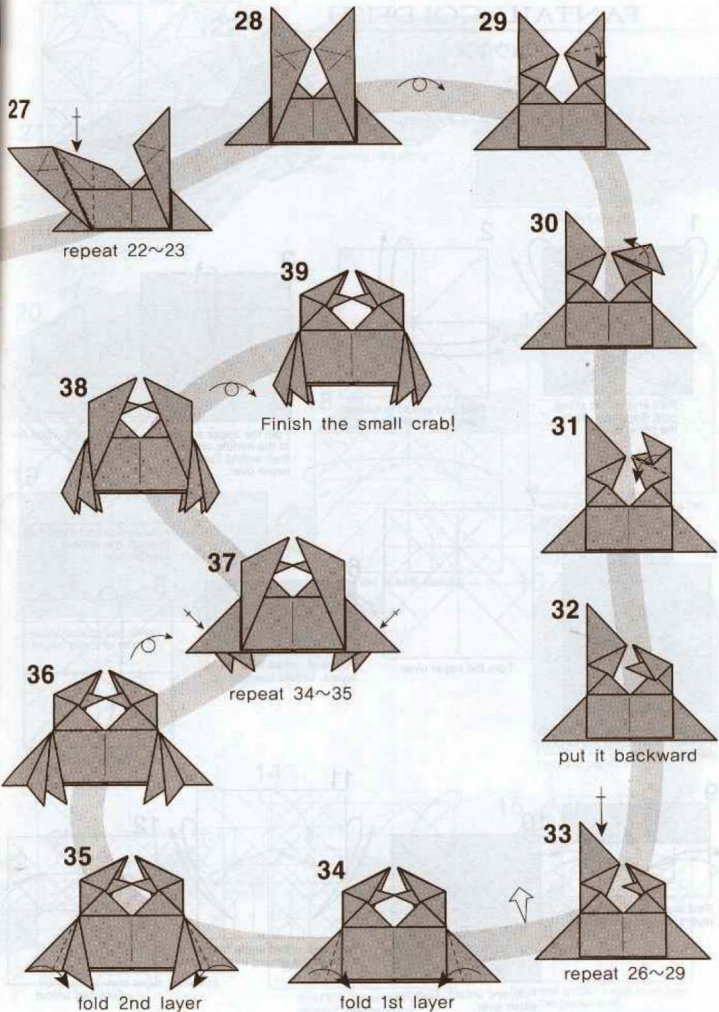

# FANTAIL GOLDFISH

## リュウキン

Model & Diagrams by Ares Alanya

M 2008 • 12 • 30x

D 2009 • 12 • 24

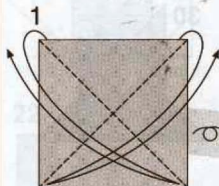
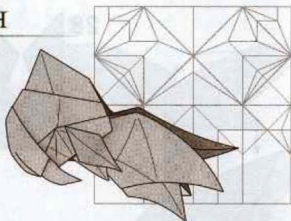

1  
Fold and unfold along both diagonals. Turn the paper over.

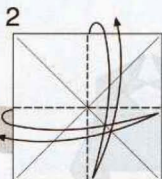

2  
Fold and unfold in halves. Turn the paper over.

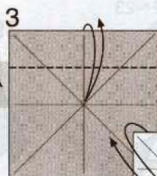

3  
Fold the upper edge to the middle crease then unfold. Turn the paper over.

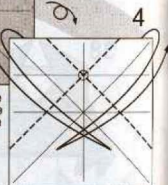

4  
Fold and unfold diagonals through the circled intersection.

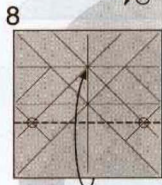

5  
Fold in half.

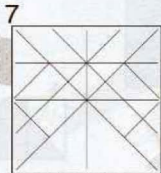

6  
Turn the paper over.



7  
Fold and unfold through all layers. Unfold everything.

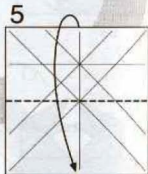

8  
Fold and unfold through all layers. Unfold everything.

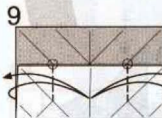

9  
Fold and unfold through all layers. Unfold everything.

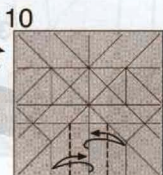

10  
Fold and unfold. Turn the paper over.

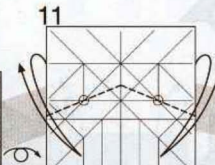

11  
Fold and unfold angle bisectors through the circled intersections

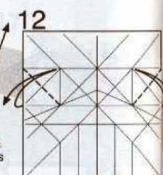

12  
Fold and unfold.



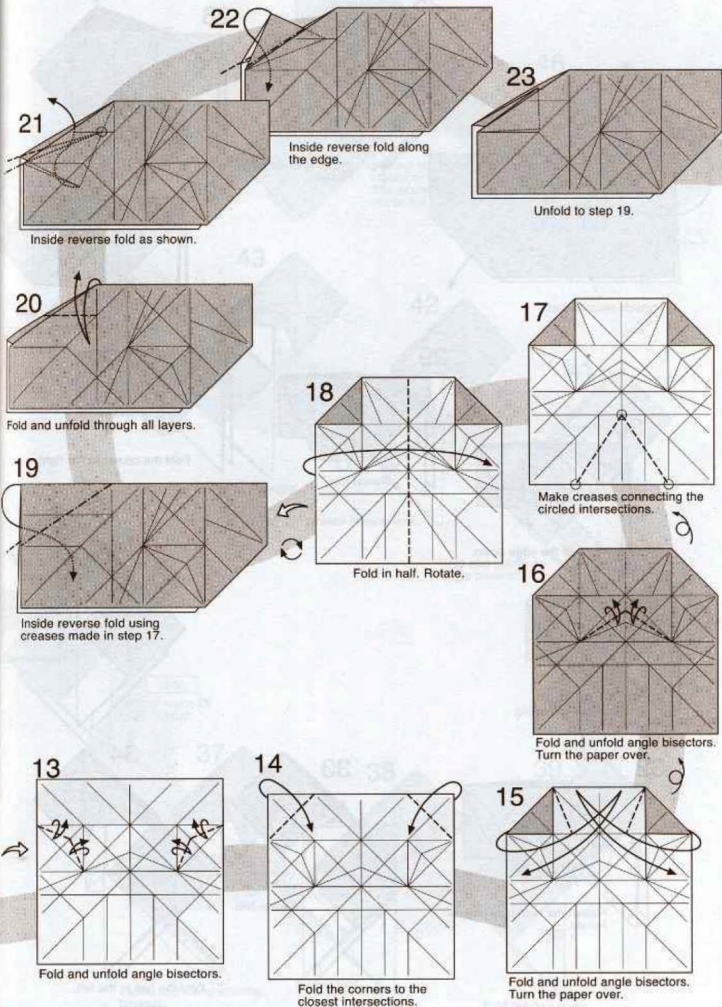

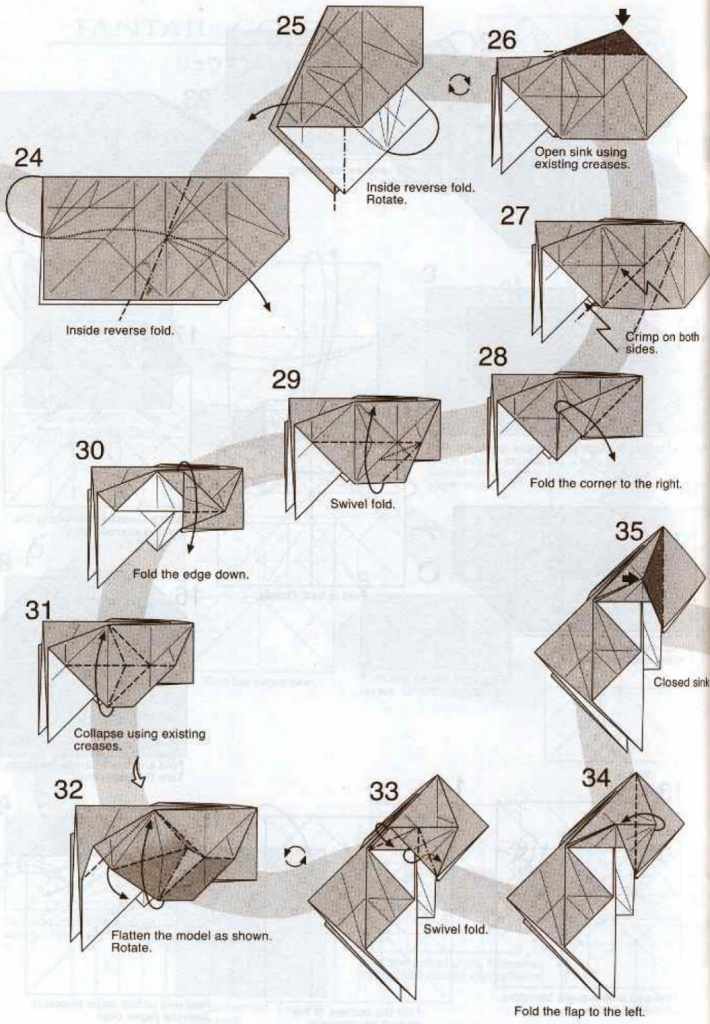

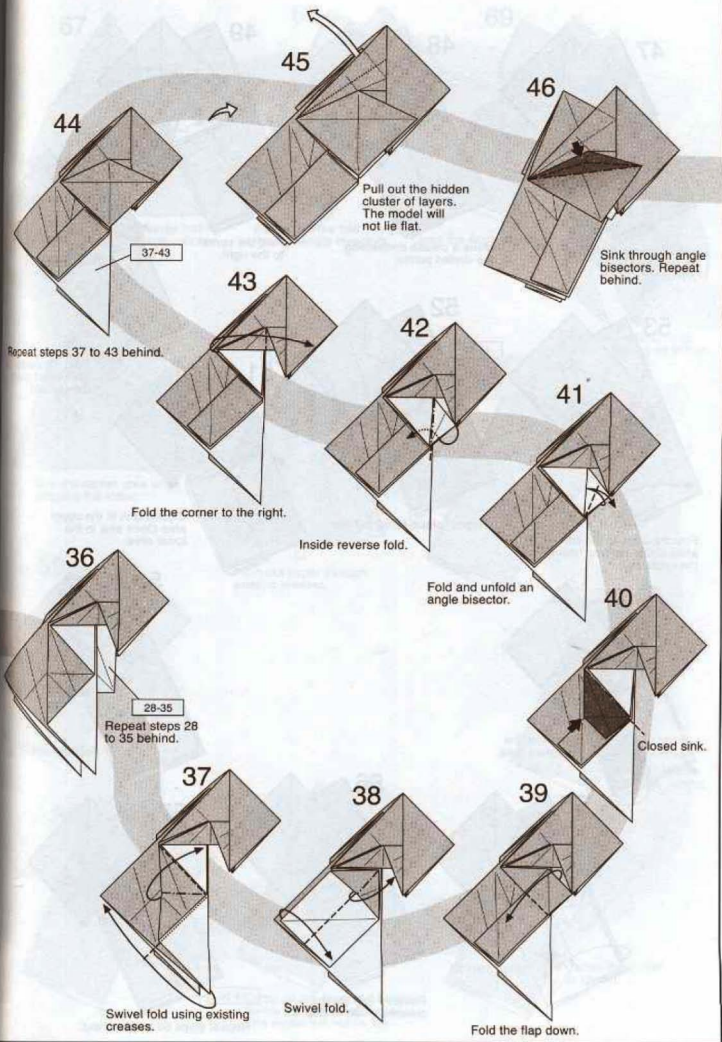

44

37-43

Repeat steps 37 to 43 behind.

45

Pull out the hidden cluster of layers. The model will not lie flat.

46

Sink through angle bisectors. Repeat behind.

43

42

Fold the corner to the right.

Inside reverse fold.

41

Fold and unfold an angle bisector.

36

28-35

Repeat steps 28 to 35 behind.

40

Closed sink.

37

38

39

Swivel fold using existing creases.

Swivel fold.

Fold the flap down.



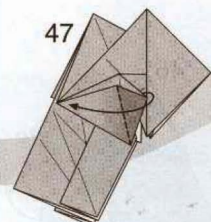

47  
Flatten the model folding the corner to the left. Repeat behind.

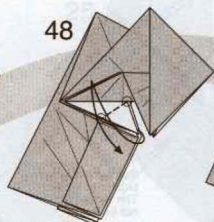

48  
Make a crease connecting the circled points.

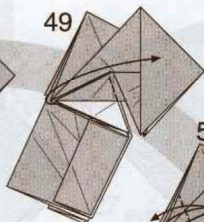

49  
Fold the corner to the right.

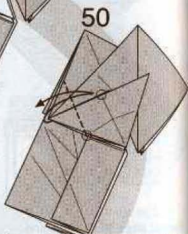

50  
Fold the corner to the circled point then unfold.

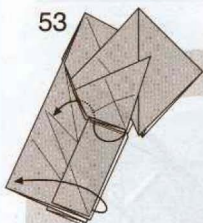

53  
Fold the edge to the left while inside reverse folding the upper part.

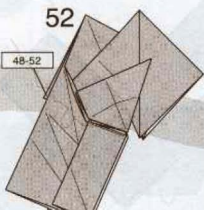

52  
Repeat steps 48-52 behind.

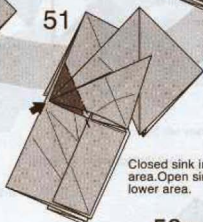

51  
Closed sink in the upper area. Open sink in the lower area.

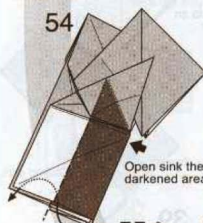

54  
Open sink the darkened area.

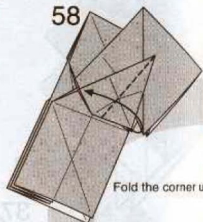

58  
Fold the corner up.

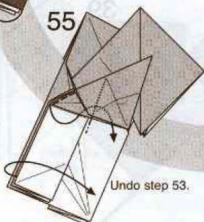

55  
Undo step 53.

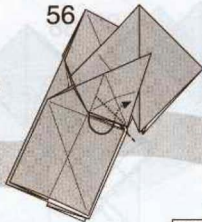

56  
Reverse fold using creases made in step 43.

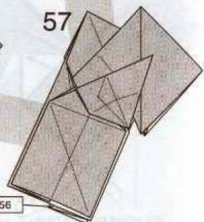

57  
Repeat steps 53 to 56 behind.



67

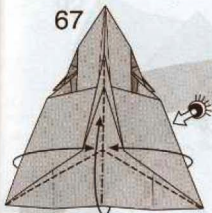

Close the model inside reverse folding the lower edge using existing creases.

68

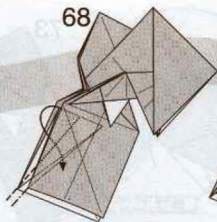

Inside reverse fold through angle bisectors.

69

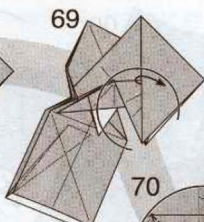

Open the edge slightly.

70

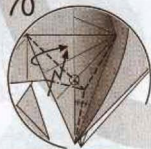

Bring the pectoral fin to the left crimping as shown.

66

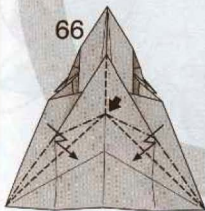

Sink the center area while crimping the sides.

65

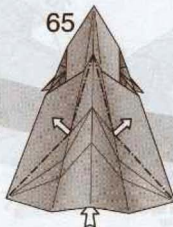

Push out paper through existing creases.

64

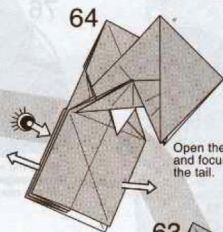

Open the layers and focus on the tail.

59

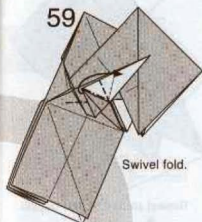

Swivel fold.

63

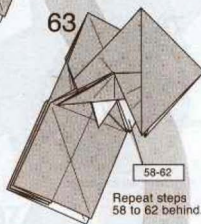

Repeat steps 58 to 62 behind.

60

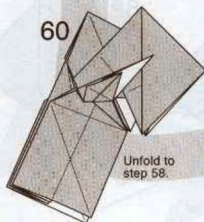

Unfold to step 58.

61

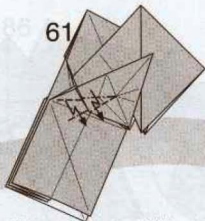

Crimp on the front and hidden layers using existing creases. The model will not lie flat.

62

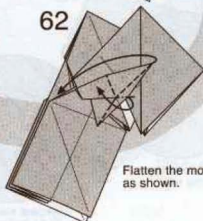

Flatten the model as shown.

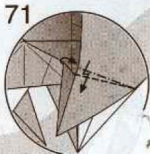

71  
Crimp as shown to flatten the model.

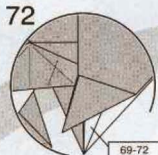

72  
Repeat steps 69 to 72 behind.

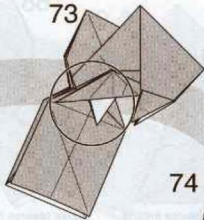

73  
Focus on the abdominal fin.



74  
Squash fold.



77  
Fold up the flap, do not crease. Notice the arrangement of layers.



76  
Wrap the near layer behind. Rearrange the layers to do the next step.

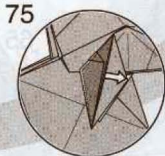

75  
Pull out a hidden layer.

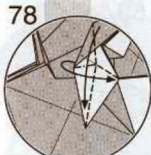

78  
Collapse as shown.

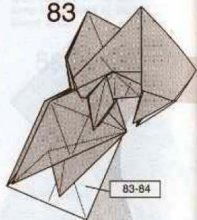

83  
Repeat steps 83 to 84 behind.



79  
Fold one layer to the left.

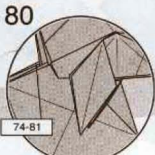

80  
Repeat steps 74 to 81 behind.

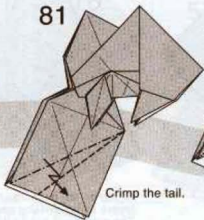

81  
Crimp the tail.

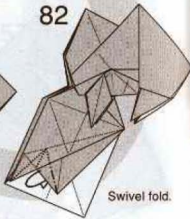

82  
Swivel fold.

92

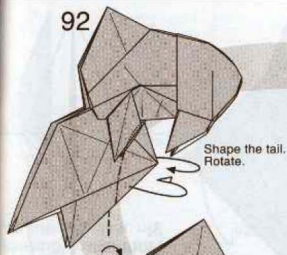

91

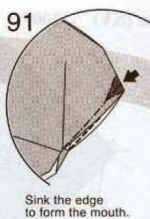

90

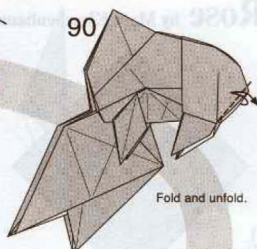

93

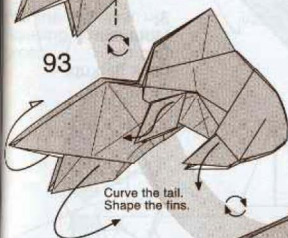

89

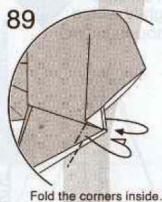

94

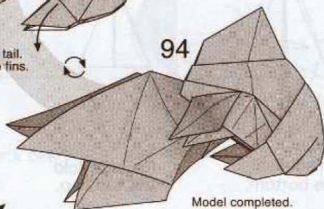

88

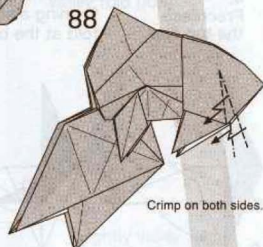

84

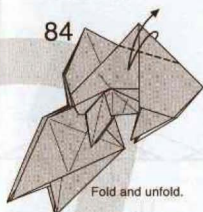

85

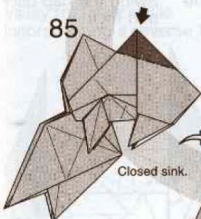

86

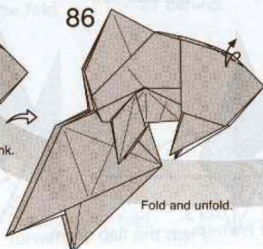

87

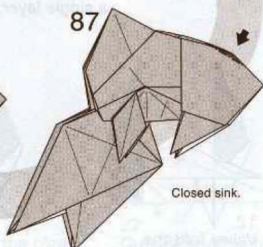



# Rose by Marc Kirschenbaum (NY) 2007

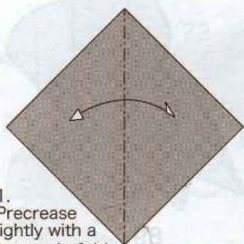

1. Precrease lightly with a mountain fold.

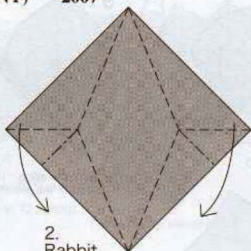

2. Rabbit ear the sides.

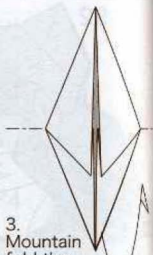

3. Mountain fold the back flap up.



4. Precrease the top flap.

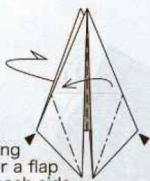

5. Swing over a flap at each side, forming a squash fold at the bottom.



6. Reverse fold the top flap.

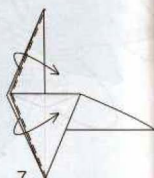

7. Wrap around a single layer.

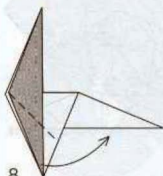

8. Valley fold up.

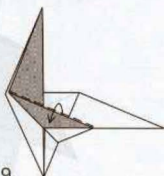

9. Wrap around a single layer.

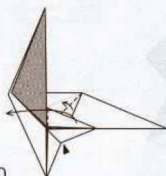

10. Swing over, squashing the side flat.

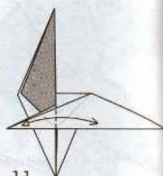

11. Swing the flap back and forth.

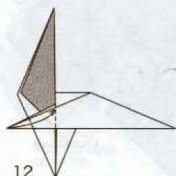

12. Valley fold the tip to the crease.

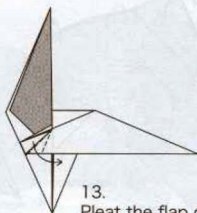

13. Pleat the flap down.

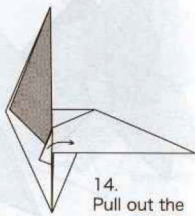

14. Pull out the top two folds.



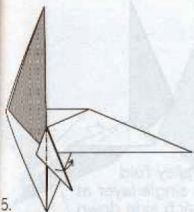

15.  
Fold the top layer up,  
releasing the trapped  
paper.

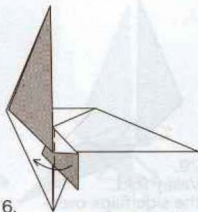

16.  
Valley fold the flap over.

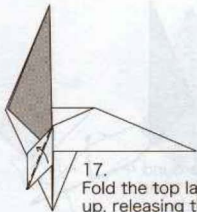

17.  
Fold the top layer  
up, releasing the  
trapped paper.

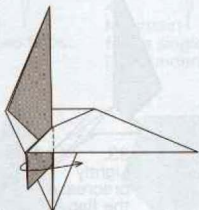

18.  
Swing the flap back over.

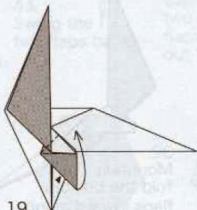

19.  
Squash fold.

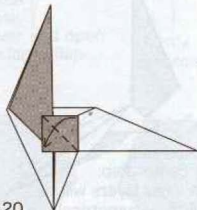

20.  
Valley fold down.

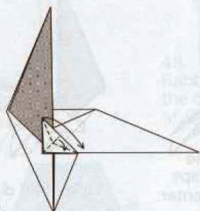

21.  
Valley fold over while  
incorporating a reverse fold.

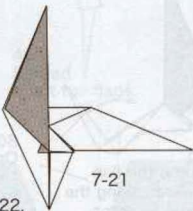

22.  
Repeat steps  
7-21 behind.

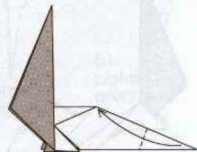

23.  
Lightly valley fold  
the flap up.

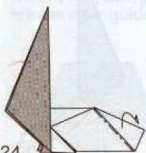

24.  
Lightly mountain  
fold behind.



25.  
Lightly valley fold  
forward.

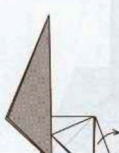

26.  
Unfold the pleat.

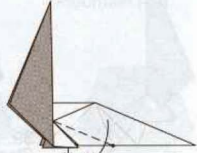

27.  
Outside reverse fold.

28. Wrap around a single layer at each side.

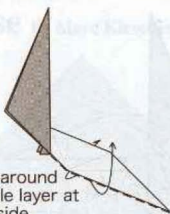

29. Valley fold the side flaps over, Repeat behind.

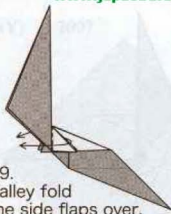

30. Valley fold a single layer at each side down.

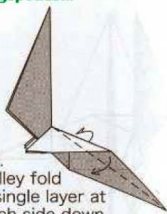

31. Closed sink the center flap. The inner layers will be slightly assymetrical.

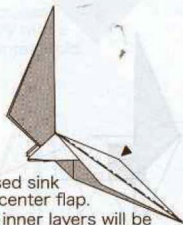

32. Mountain fold the bottom flaps inward along the angle bisector.

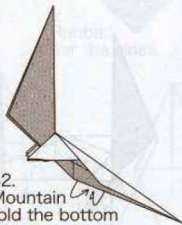

33. Lightly precrease the flap.

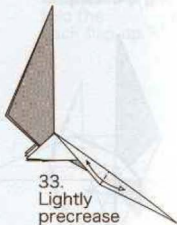

34. Reverse fold up to align with the crease.

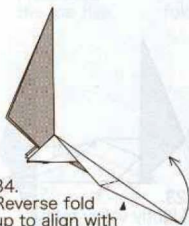

35. Crimp the flap inwards along the angle bisector.

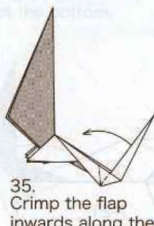

36. Open out the cluster of flaps along the center.

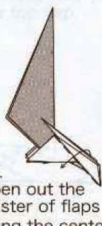

37. Valley fold down.

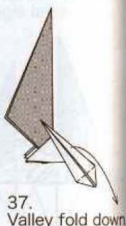

38. Unsink a single layer.

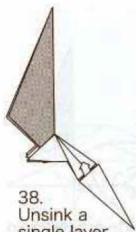

39. Close the cluster of flaps back up..

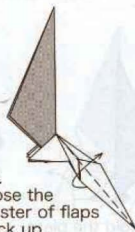

40. Pull out a single layer from the flap, allowing a tiny sink to form on the interior. Repeat behind.

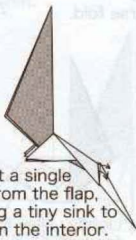

41. Crimp downwards.

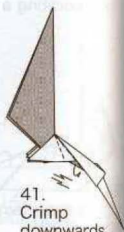



42. Swing over two flaps.



43. Mountain fold a single layer underneath.



44. Swing the two flaps back.



45. Swing the two small flaps over and open out the large flap.

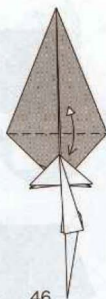

46. Lightly precrease.

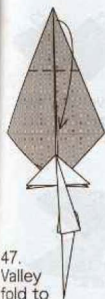

47. Valley fold to the crease.



48. Rabbit ear the clusters of flaps.

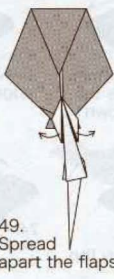

49. Spread apart the flaps.



50. Wrap around a single layer.



51. Lightly precrease.



52. Rabbit ear, using the crease as a guide.



53. Precrease.



54. Precrease again.



55. Precrease with a mountain fold.



56. Spread apart the sides, allowing a squish to form.



57. Valley fold the corner.



58. Valley fold the flap in half.



59. Reverse fold.



60. Flip the flap up.

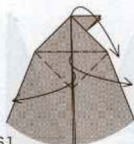

61. Squash fold the top section down.



62. Wrap a flap around at each side, tucking into the pockets.



63. Precrease with mountain folds.



64. Collapse down wards.



65. Reverse fold the center flap through.



66. Pull a single layer through at each side.

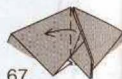

67. Pleat the center flap.



68. Swivel the layers behind.



69. Swivel at the other side, and slide the center flap down to flatten.



70. Swivel the protruding edge behind.

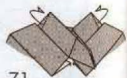

71. Swivel the side edges behind.



72. Crimp the center flap upwards.



73. Valley fold the tiny flap.



74. Mountain fold the edges behind.



75. Mountain fold the corners.

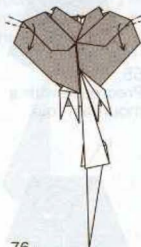

76. Pleat the sides down. The model will be slightly 3-D.

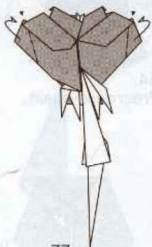

77. Swivel the sides behind.



78. Crimp the right side slightly. Fold out the petals.

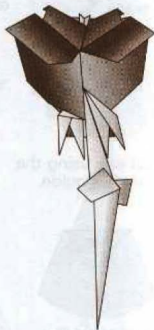

79. Completed Rose.  
© 2007 Marc Kirschenbaum



# Wing-heart

Hoàng Tiến Quyết

Model: May 2010

Diagram: June 2010

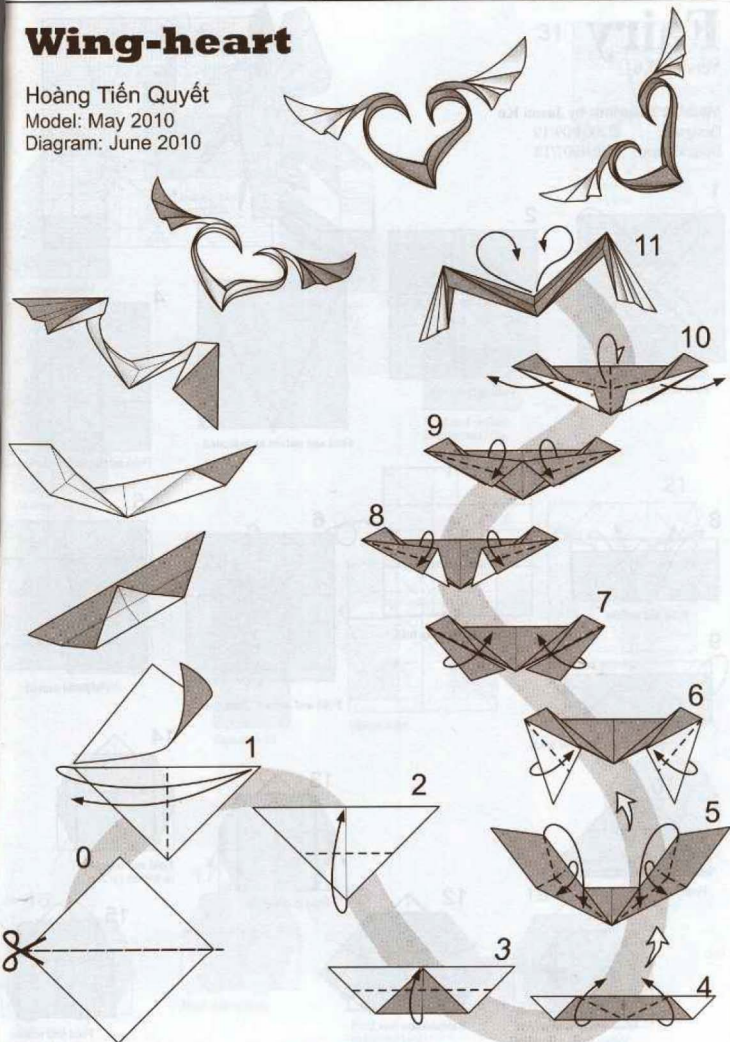

# Fairy

Version 5.6

Model & Diagrams by Jason Ku

Designed: ©2004/09/19

Diagrammed: ©2010/07/13

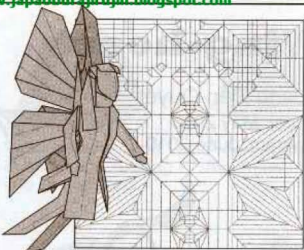

1 Start color side up. Fold and unfold.

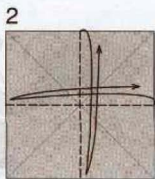

2 Fold and unfold.

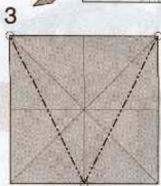

3 Fold and unfold as indicated.



4 Fold and unfold as indicated.

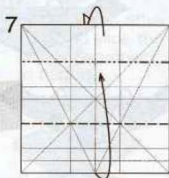

7 Valley and mountain fold.



8 Fold and unfold.

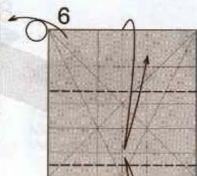

6 Fold and unfold. Turn over.

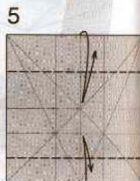

5 Fold and unfold.

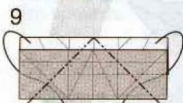

9 Reverse folds.

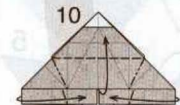

10 Petal fold.

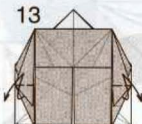

13 Fold and unfold.

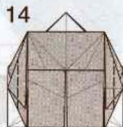

14 Fold and unfold in halves (1/2).

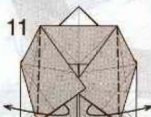

11 Valley fold.

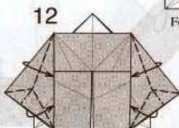

12 Rabbit-ear.

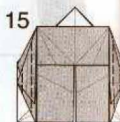

15 Fold and unfold in fourths (1/4).



Fold and unfold.

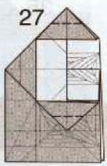

Fold and unfold in halves (1/2).

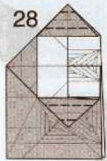

Fold and unfold in fourths (1/4).



Fold and unfold in eighths (1/8).

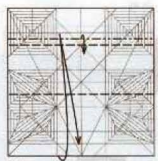

Fold and unfold. Then pleat.



Reverse folds.

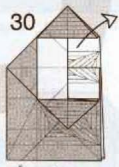

Unfold.

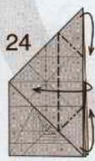

Petal fold.



Squash fold.

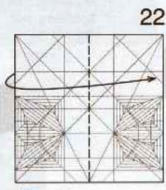

Valley fold.

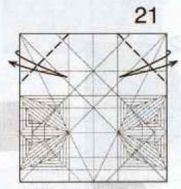

Fold and unfold.

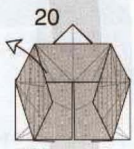

Unfold.

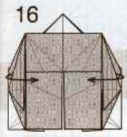

Fold over.

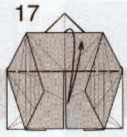

Fold and unfold.

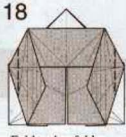

Fold and unfold in halves (1/2).

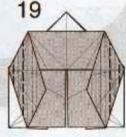

Fold and unfold in fourths (1/4).

32

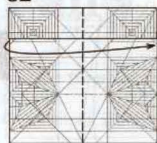

Valley fold.

33

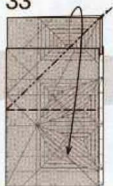

Squash fold.

34

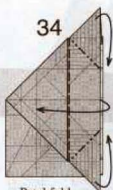

Petal fold.

35

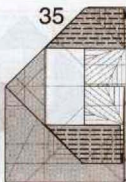

Fold and unfold  
in eighths (1/8).

41

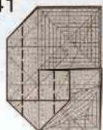

Fold and unfold  
in halves (1/2).

40



Reverse fold.

39

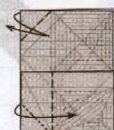

Fold and unfold.  
Squash fold.

38



Valley fold.

37

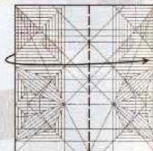

Valley fold.

42

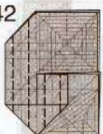

Fold and unfold  
in fourths (1/4).

Unfold.

43

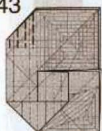

Fold and unfold  
partially in eighths (1/8).

45

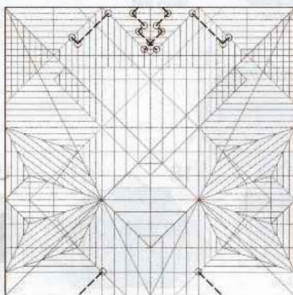

Fold and unfold as indicated.

46

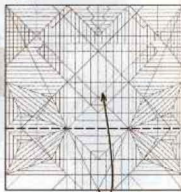

Valley fold.

44

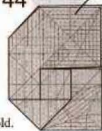

Unfold.



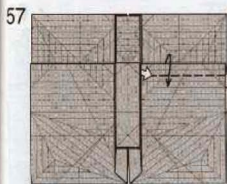

57 Valley fold while unlocking some paper.

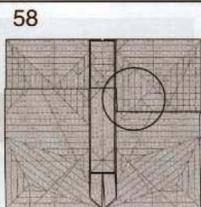

58 Cut away top layer to see below...

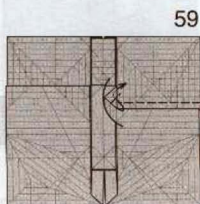

59 Reverse fold.

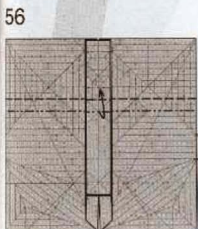

56 Pleat.

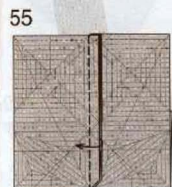

55 Valley fold.

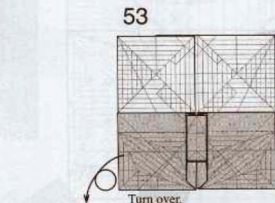

53 Turn over.

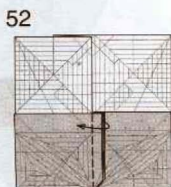

52 Valley fold.

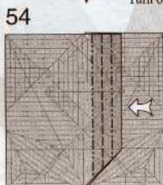

54

Open sink in and out in fourths (1/4).

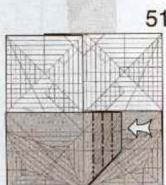

51

Open sink in and out in fourths (1/4).

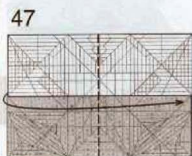

47 Valley fold.



48 Reverse fold.

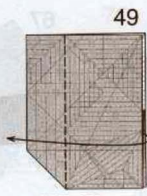

49 Valley fold.

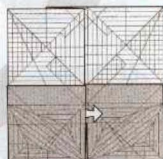

50 Pull out paper (unsink).

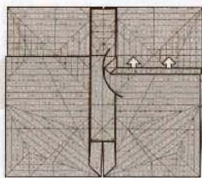

60

Pull out paper (unsink).

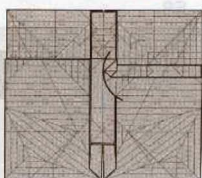

61

Return to normal view...

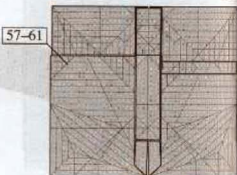

62

Repeat steps 57-61 on left.

64

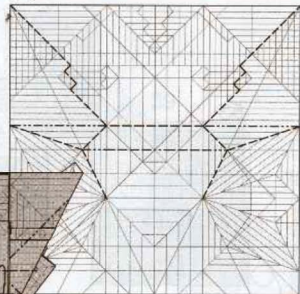

Petal and squash along existing creases.

63

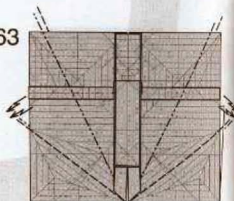

Crimp on both sides.

65

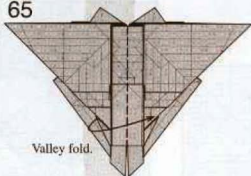

Valley fold.

69

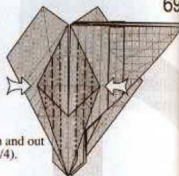

Open sink in and out in fourths (1/4).

66

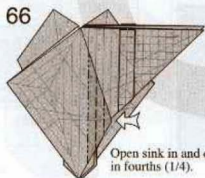

Open sink in and out in fourths (1/4).

67

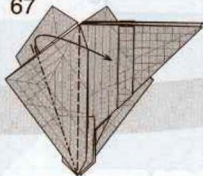

Squash fold.

68

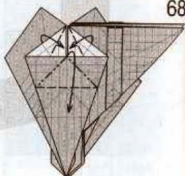

Petal fold.

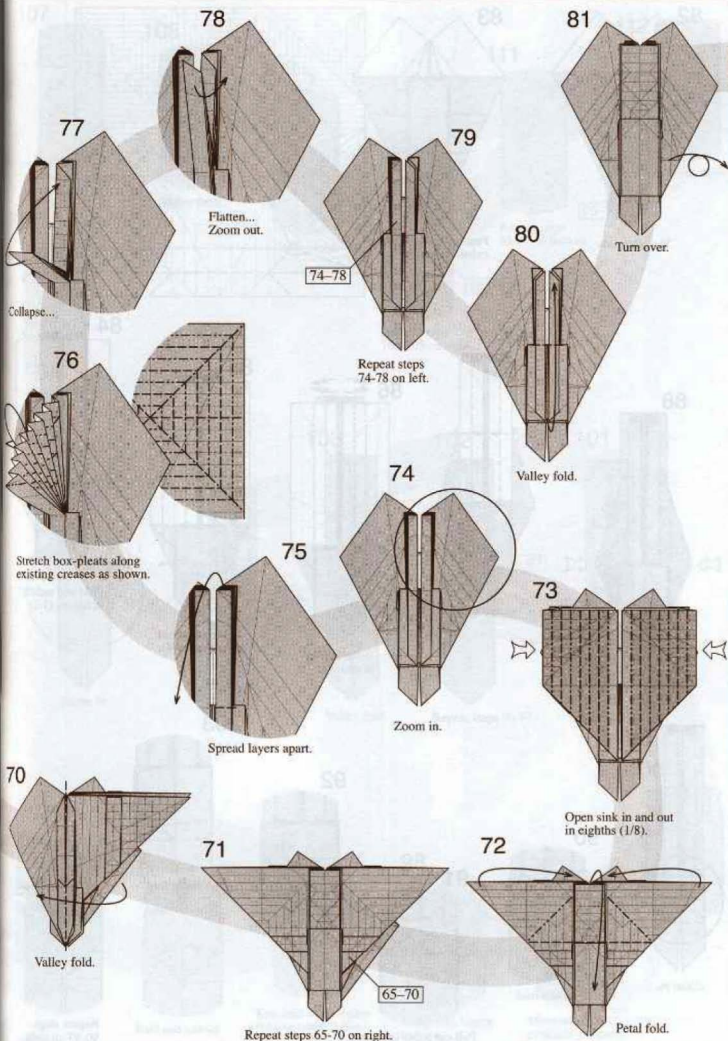

82

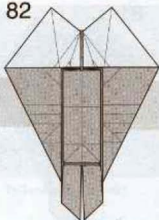

The other side...

83

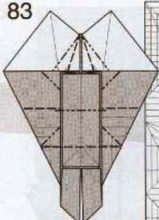

Petal and squash along existing creases.

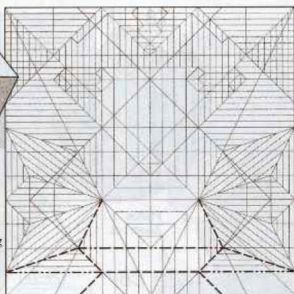

88

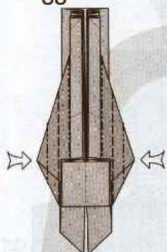

Open sink in and out in fourths (1/4).

87



Valley fold.

86



Reverse fold in and out.

85



Fold and unfold in fourths (1/4).

84



Fold and unfold in halves (1/2).

89



Zoom in.

90

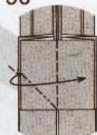

Squash fold.

91



Pull out paper (unsink).

92



Valley fold.

93



Valley fold.

94



Repeat steps 90-93 on right.

90-93



107

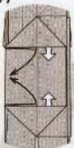

Pull out paper (unsink).

108



Valley fold.

109



Valley fold.

111



Repeat steps 95-97 on bottom.

112



Bring dark layers to front.

106



Squash fold.

110



Repeat steps 105-109 on right.

105-109

95-97

105

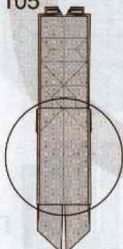

Zoom in.

104



Turn over.

103



Valley fold.

102



Repeat steps 96-97.

96-97

101



Valley fold.

95



Open sink.

96



Fold and unfold.

97



Kite fold while valley folding internal flap.

98



Bring dark layers to front.

99



Mountain fold protruding corners.

100



Zoom out.

フェアリー/ジェイソン・クー (アメリカ合衆国)

113



Zoom out.

114



Repeat steps  
101-103.  
101-103

115



Valley fold.

116

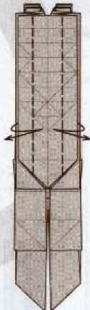

Fold and unfold.

124



Collapse as indicated  
along existing creases.

118



Valley fold.

117



Open sink.

119



Valley fold.  
Swivel fold  
at bottom.

120



Unfold but  
keep reversed triangle.

121



Closed sink.

122



Repeat steps  
119-121 on left.

123



Petal fold.  
Model will not lie flat  
Side view...

125



Open layers...

126



...and collapse as indicated along existing creases. Repeat behind.

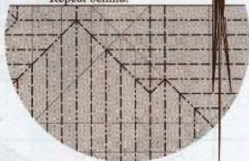

127



Top view...

128

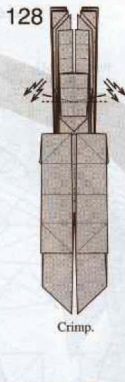

Crimp.

129

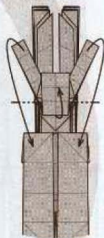

Mountain fold. Let middle flap fold up.

132

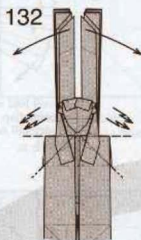

Crimp.

131

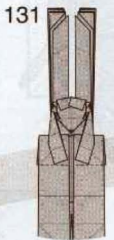

Shape face with mountain folds.

130

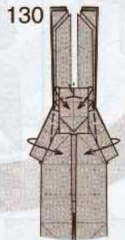

Valley fold. Rabbit ear top.

133

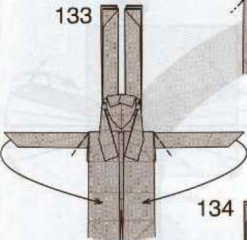

Valley fold.

134

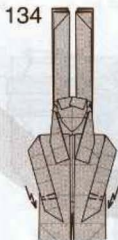

Pleat.

135

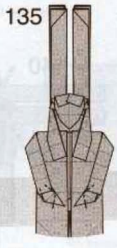

Shape hands with mountain folds.

136

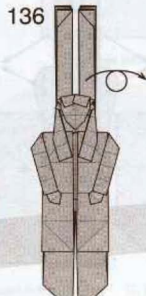

Turn over.

137

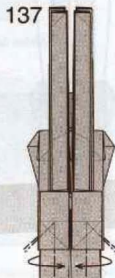

Valley fold. Swivel fold top.

フェアリー/ジェイソン・クー (アメリカ合衆国)

145



Finished.

144

Partially fold in half while shaping body and legs. Turn over.

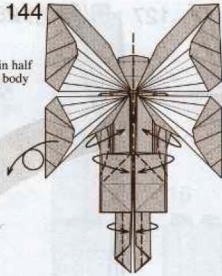

143

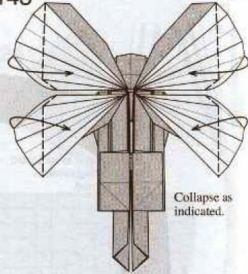

Collapse as indicated.



142

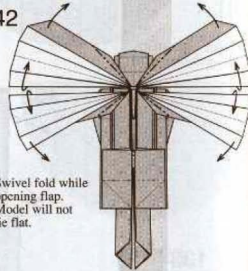

Swivel fold while opening flap. Model will not lie flat.

138



Valley fold.

139

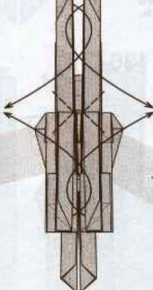

Valley fold.

140

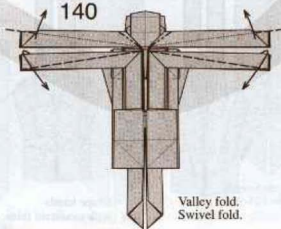

Valley fold.  
Swivel fold.

141

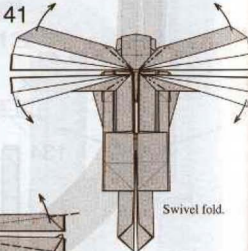

Swivel fold.



# TRIPLANO FOKKER DR1 "Red Baron" 2009 v2

Dedicated to Lorenzo Beber (26/12/1928 - 17/10/2009)

© Alessandro Beber

Design: October/November 2009

Diagrams: November/December 2009

Paper: you need a square of at least 50cm in size of thin and strong paper.

Sandwich paper (tissue + aluminium) could be a good choice. You may have better results using higher quality papers (quite thin and if necessary treated with MC) and wet-finished.

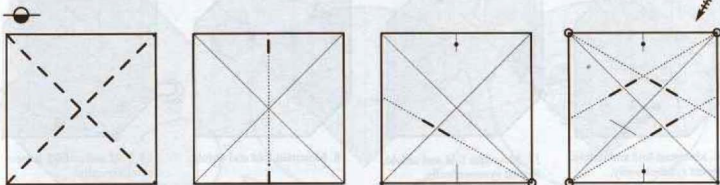
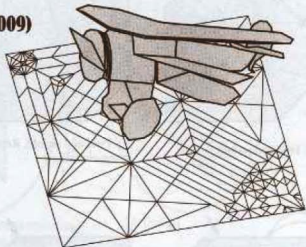

1. White side up. Fold and unfold along the diagonals.

2. Fold and unfold in half, making just a pinch at the sides.

3. 30° fold, making just a pinch on the diagonal.

4. Repeat on the other 3 corners. Then turn the paper over.

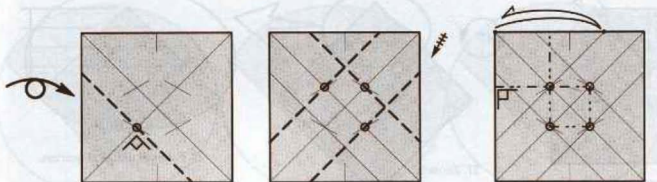

5. Fold and unfold.

6. Repeat 3 times more.

7. Mountain fold and unfold.

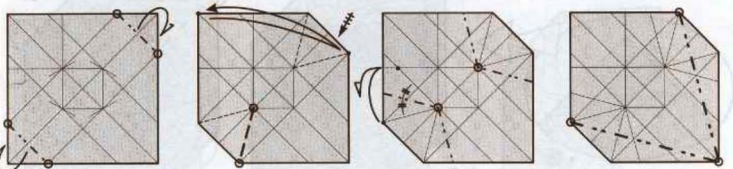

8. Mountain fold 2 corners.

9. Fold and unfold. Repeat 4 times

10. Mountain fold and unfold along angle bisectors.

11. Mountain fold and unfold.

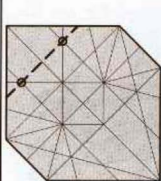

12. Fold and unfold.



13. Fold and unfold. Repeat symmetrically.

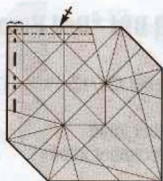

14. Mountain fold and unfold. Repeat symmetrically.

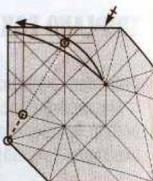

15. Fold and unfold. Repeat symmetrically.

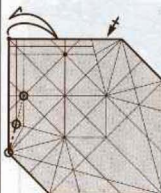

16. Mountain fold and unfold. Repeat symmetrically.



17. Mountain fold and unfold. Repeat symmetrically.

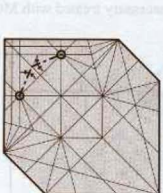

18. Mountain fold and unfold.

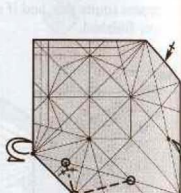

19. Fold and unfold. Repeat symmetrically.

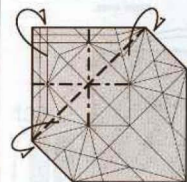

20. Collapse as a preliminary fold.

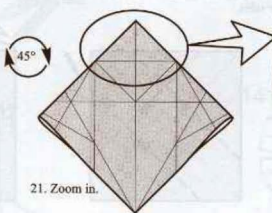

21. Zoom in.

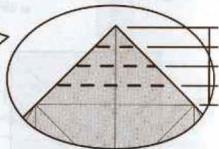

22. Fold and unfold in quarters.

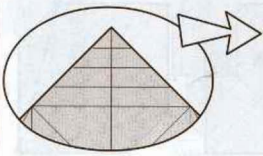

23. Unfold.

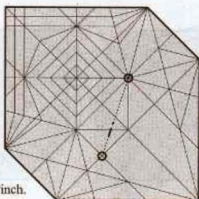

24. Pinch.

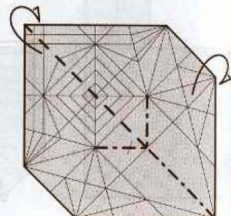

25. Collapse on the existing creases.

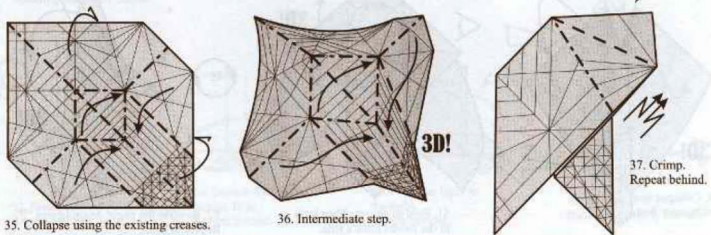
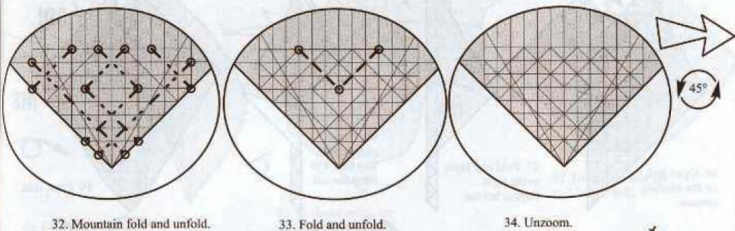
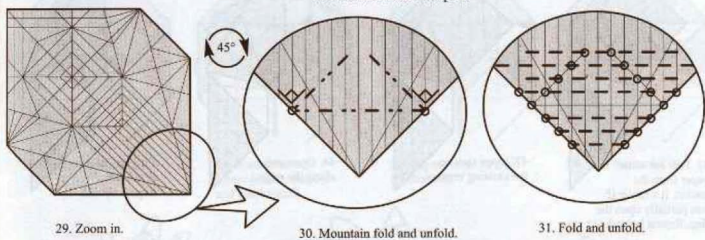
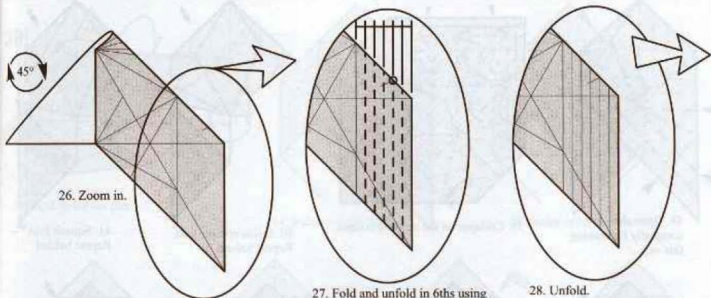



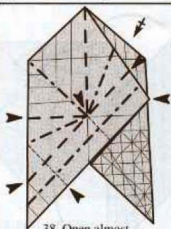

38. Open almost completely for making this step...

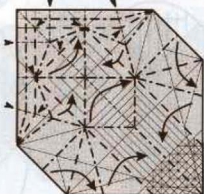

39. Collapse on the existing creases.

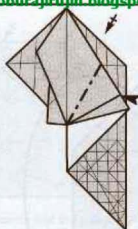

40. Inside reverse fold. Repeat behind.

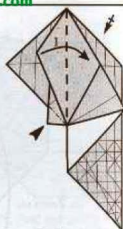

41. Squash fold. Repeat behind.

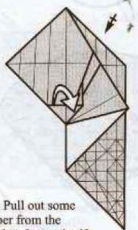

42. Pull out some paper from the pocket. It's easier if you partially open the flap. Repeat behind.

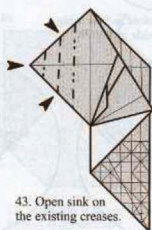

43. Open sink on the existing creases.



44. Open sink along the edge.

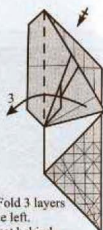

45. Fold 3 layers to the left. Repeat behind.

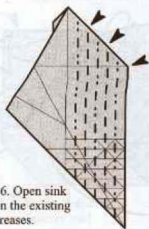

46. Open sink on the existing creases.

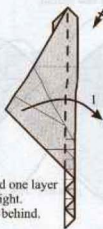

47. Fold one layer to the right. Repeat behind.



48. Open partially the flap that will form the tail.

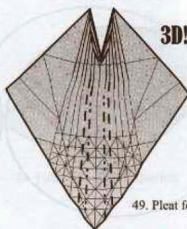

49. Pleat fold.

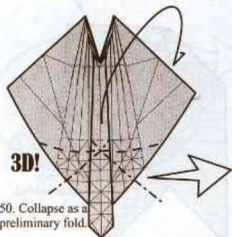

50. Collapse as a preliminary fold.

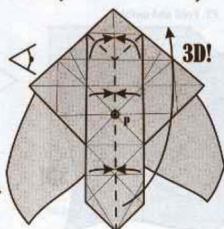

51. Fold as shown. Then look to the model from a side.

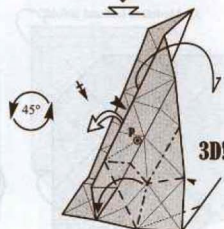

52. Reverse the paper around point "P". Repeat behind.



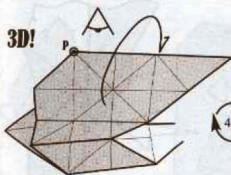

53. Fold down the flap.

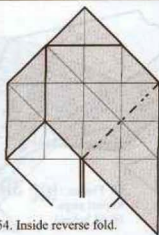

54. Inside reverse fold.

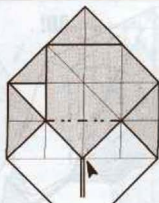

55. Inside reverse fold.

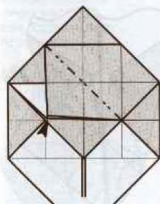

56. Open sink the flap.

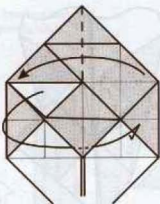

57. Book fold two layers (one in front and one behind).

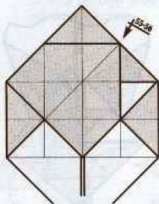

58. Repeat steps 55-56 on this side.

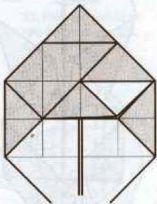

59. Turn the model over.

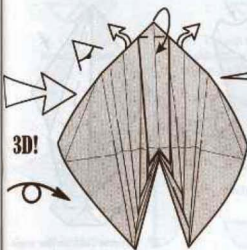

60. Fold down the tip, releasing the paper behind.

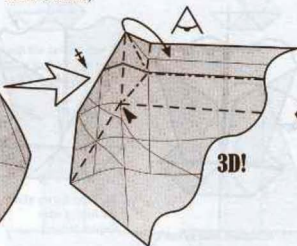

61. Collapse using the existing creases.

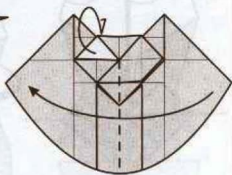

62. Hide the white tip and fold in half.

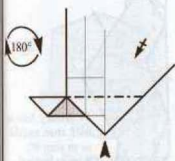

63. Inside reverse fold. Repeat behind.

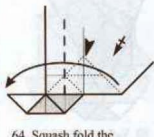

64. Squash fold the hidden flap. Repeat behind.

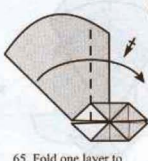

65. Fold one layer to the right. Repeat behind.

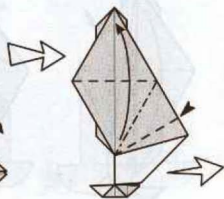

66. Squash fold. Don't flatten completely the tail.

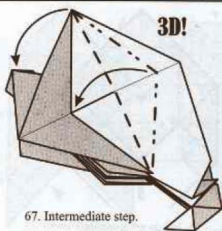

67. Intermediate step.

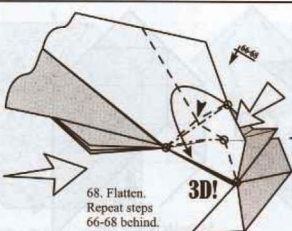

68. Flatten.  
Repeat steps  
66-68 behind.

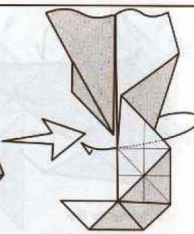

69. Open in half the tail.

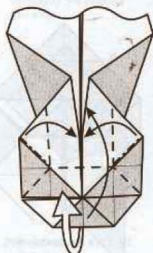

70. Collapse on existing  
creases.

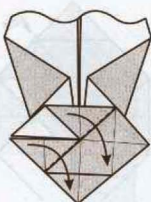

71. Fold the 2 flaps down.

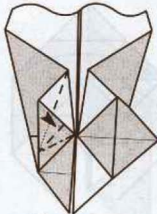

72. Reverse fold the edge.

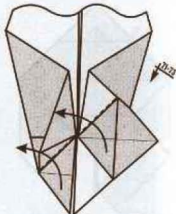

73. Fold the 2 flaps back.  
Repeat steps 71-73 on the right.

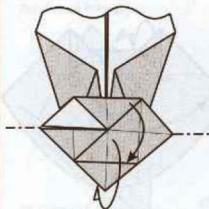

74. Mountain fold.



75. Mountain fold in half.

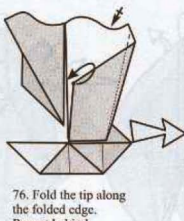

76. Fold the tip along  
the folded edge.  
Repeat behind.

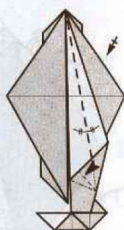

77. Reverse fold on the angle  
bisector. Repeat behind.



78. Fold one flap down.  
Repeat behind.

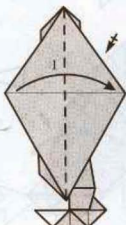

79. Fold one layer to the  
right. Repeat behind.

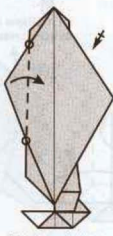

80. Valley fold along  
the folded edge.  
Repeat behind.

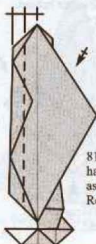

81. Valley fold in  
half, then unfold  
as in step 80.  
Repeat behind.



82. Open sink on the creases you've just done. Unfold partially for making this.

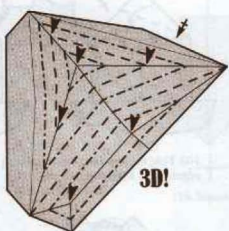

83. Intermediate step. Repeat behind.

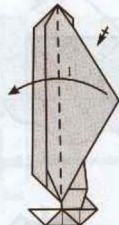

84. Fold one layer to the left. Repeat behind.

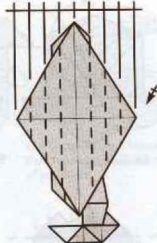

85. Fold and unfold the two layers in quarters. Repeat behind.

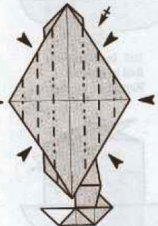

86. Open sink. Repeat behind.

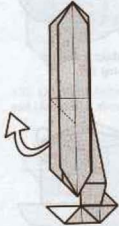

87. Put out the central flap at right angles to the folded edge making a kind of crimp.

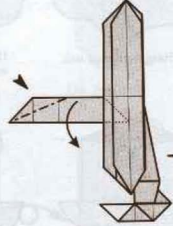

88. Spread sink.

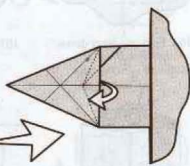

89. Pull out some trapped paper.

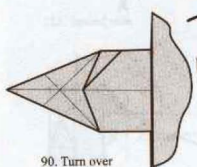

90. Turn over and rotate.

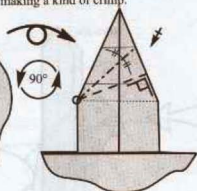

91. Fold and unfold. Repeat on the right.

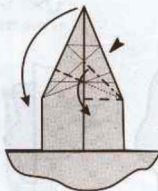

92. Squash fold.

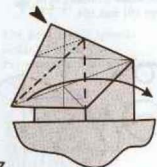

93. Squash fold.

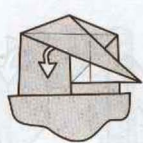

94. Pull out some paper.

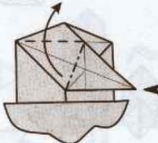

95. Squash fold.

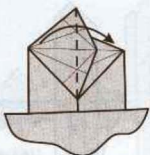

96. Fold the tip to the right.

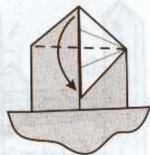

97. Fold one flap down.



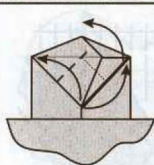

98. Fold up.

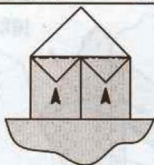

99. Inside reverse fold 2 flaps.

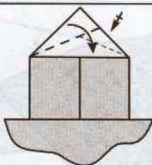

100. Fold the two raw edges to the folded edge.



101. Make it thinner.



102. Fold one layer down.

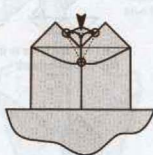

103. Triangular spread sink.

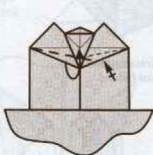

104. Make it thinner as in step 101.

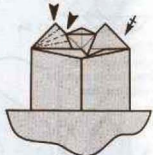

105. Inside reverse fold in quarters. Repeat on the right.

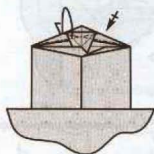

106. Make it thinner as in steps 101 and 104.

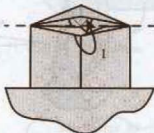

107. Fold one layer up.

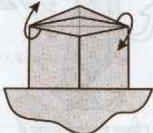

108. Rotate the propeller.

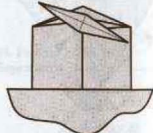

109. Turn over and rotate.

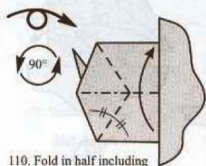

110. Fold in half including an inside reverse fold.

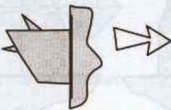

111. Unzoom.

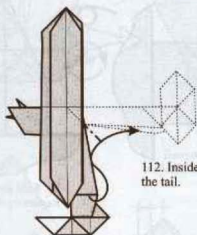

112. Inside reverse fold the tail.

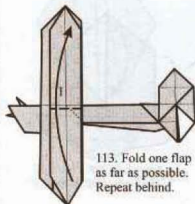

113. Fold one flap as far as possible. Repeat behind.

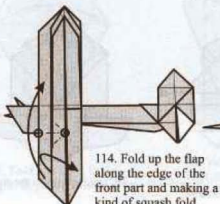

114. Fold up the flap along the edge of the front part and making a kind of squash fold.

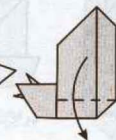

115. Fold the flap down.

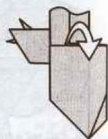

116. Unfold.





117. Collapse again changing the direction of some creases.

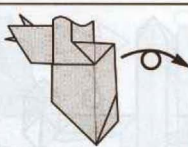

118. Like this. Now, it will be shown the back side of the flap, which will form the wheel.

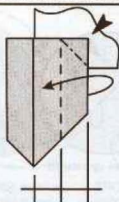

119. Squash fold.

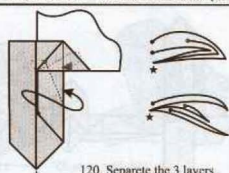

120. Separate the 3 layers. Don't change the direction of any fold.

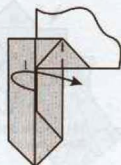

121. Fold one layer to the right.

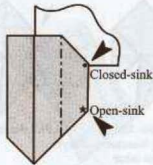

122. Open sink below \* and closed sink above. \*

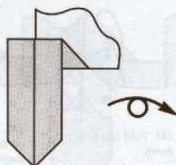

123. Turn over.

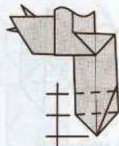

124. Fold and unfold one flap as far as possible and then in half.



125. Spread sink.

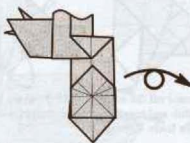

126. Turn over.

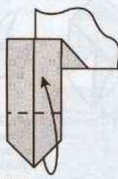

127. Fold up.

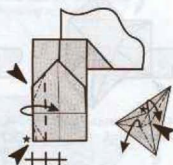

128. Fold in half, spread-sinking 2 corners. Pay attention to the lower one.

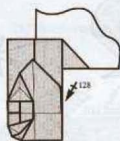

129. Repeat step 128 on the right.

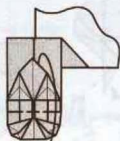

130. Fold the flap down.

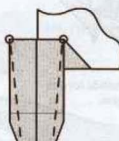

131. Make it thinner.

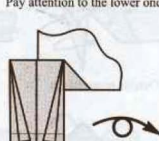

132. Turn over.



133. Bring one flap in front of the wheel.

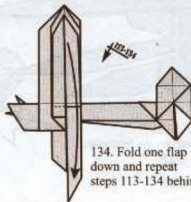

134. Fold one flap down and repeat steps 113-134 behind.

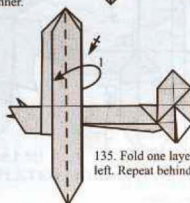

135. Fold one layer to the left. Repeat behind.

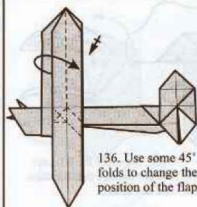

136. Use some 45° folds to change the position of the flap.

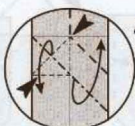

137. Close-up view of step 136.

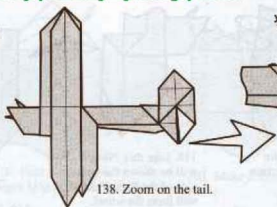

138. Zoom on the tail.

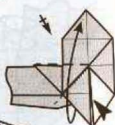

139. Squash fold. Repeat behind.

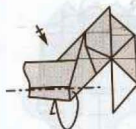

140. Mountain fold. Repeat behind.

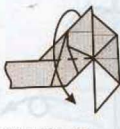

141. Fold one flap down.

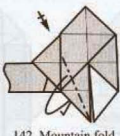

142. Mountain fold on the angle bisector. Repeat on the other side.

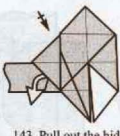

143. Pull out the hidden layer.



144. Squash fold. Repeat behind.

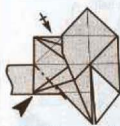

145. Inside reverse fold. Repeat behind.



146. Inside reverse fold the tip. Repeat behind.

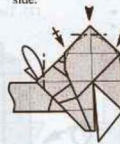

147. Round off the edges with a sink and several mountain folds. Repeat behind.

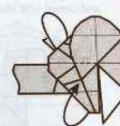

148. Fold the rudders in the correct position.

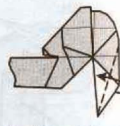

149. Valley fold on the angle bisector. Repeat behind.

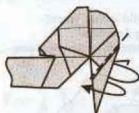

150. Outside reverse fold.

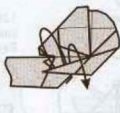

151. Outside reverse fold again.

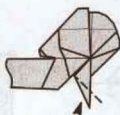

152. Inside reverse fold.

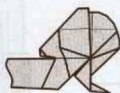

153. Completed tail.

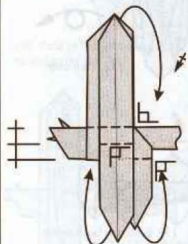

154. Fold the wings in horizontal position.

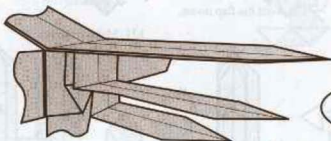

155. Like this. Zoom on the front part.



156. Open the front part, tuck the tips in the pockets and round off.

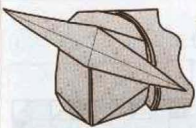

157. Like this. Now the front part is completed. Turn the model over from top to bottom.



158. Fold the flap down at right angles to the wheel. Repeat on the other wheel.



159. Valley fold the flap. There isn't a reference point. DON'T repeat on the other wheel.



160. Overlap the two flaps.

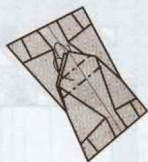

161. Lock mountain folding the 2 flaps together twice.

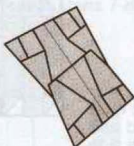

162. Like this. Turn the model over.

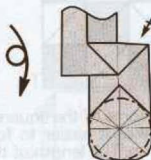

163. Round off the wheel using some mountain folds. Repeat on the other wheel.

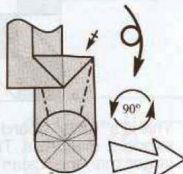

164. Shape the wheels. Then turn the model over from top to bottom.

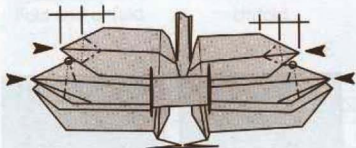

165. Inside reverse fold the tips of 4 wings.

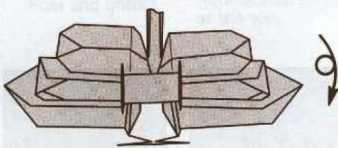

166. OK! Turn over again.

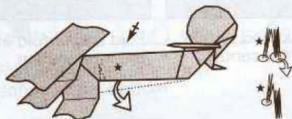

167. Pull out some layers from inside the tail making it 3D and add a small pleat fold on the external layers to round it off.

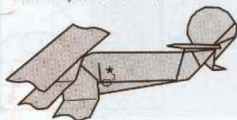

168. Like this. If desired, you can try to shape it in a different way.

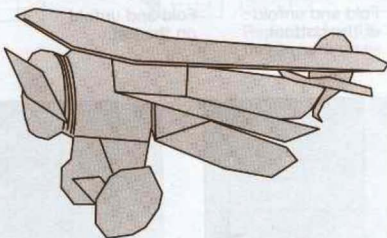

169. COMPLETED MODEL!!!



## 5 x 5 Chess Board

John Montroll

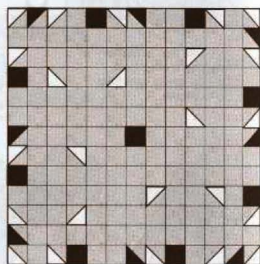

This is a "fuzzy" board since some of the squares have exposed diagonals. This makes it easier to fold and larger than the "clean" version. The length of the side of this 5 x 5 chess board is  $5/13$  that of the original square. The model uses square symmetry. The "crease pattern" shows the location of the black and white squares for the 5 x 5 board. The grey represents the hidden part. I suspect this crease pattern to be more for entertainment than analysis.

1

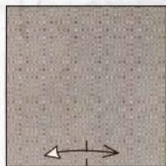

Fold and unfold  
at the bottom.

2

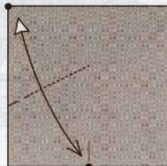

Fold and unfold  
on the left.

3

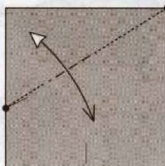

Fold and unfold  
in the center.

4

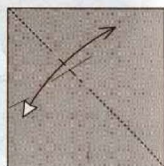

Fold and unfold  
at the intersection.

5

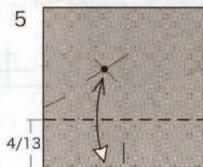

Fold and unfold.

6

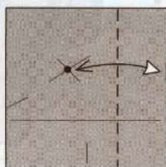

Fold and unfold.

7

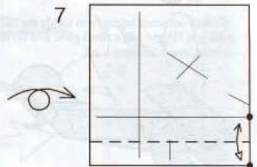

Fold and unfold.



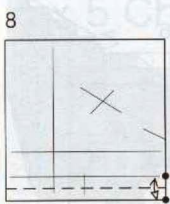

Fold and unfold.

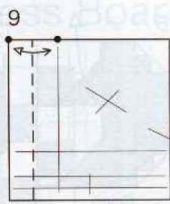

Repeat steps 7-8 on the left.

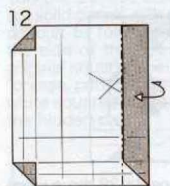
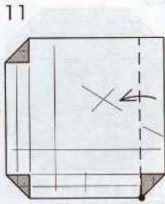
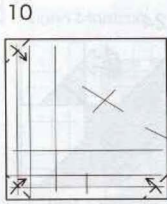

Fold and unfold.

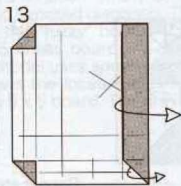

Unfold.

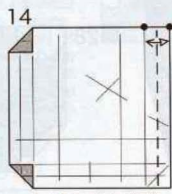

Fold and unfold.

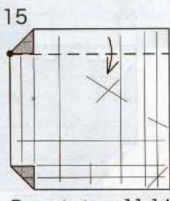

Repeat steps 11-14 at the top.

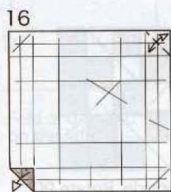

Fold and unfold at the top.  
Unfold at the bottom.

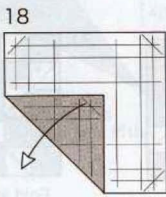
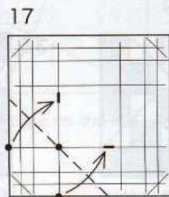

Unfold.

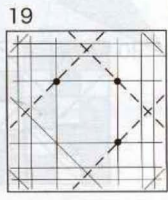

Repeat steps 17-18 three more times.

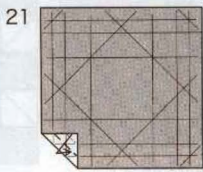
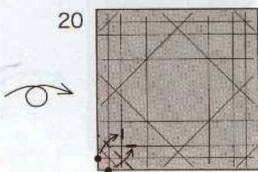

Valley-fold along the crease.

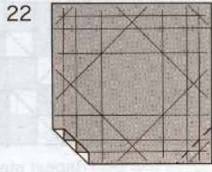

Repeat steps 20-21 three more times.

23

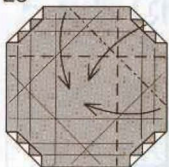

This is similar to the preliminary fold.

24

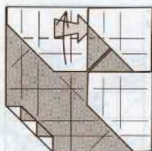

Reverse-fold.

25

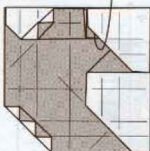

Open.

26

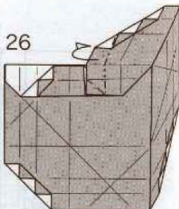

The model is 3D.

27

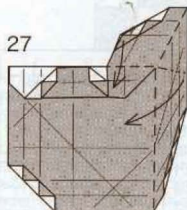

Flatten.

28

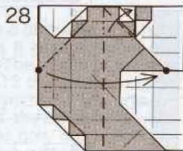

29

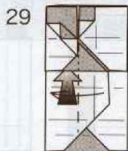

Repeat steps 24-28 three more times. You will have to be a bit creative as this goes around.

30



31

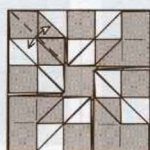

Fold and unfold.

32

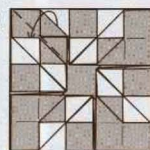

Tuck inside. Rotate 90°.

33

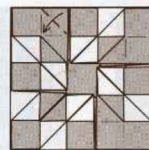

Repeat steps 30-32 three more times.

34

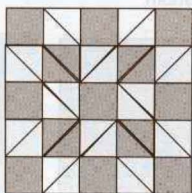

5 x 5 Chess Board

# 5 x 5 Chess Board

John Montroll

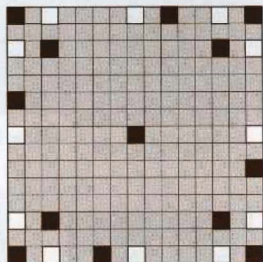

This 5 x 5 chess board is "clean" where all the squares are solid panels with no exposed diagonals. This is more difficult to fold than the "fuzzy" board. The length of the side of this 5 x 5 chess board is  $1/3$  that of the original square. The model uses square symmetry. The "crease pattern" shows the location of the black and white squares for the 5 x 5 board. The grey represents the hidden part.

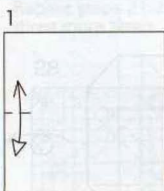

Fold and unfold  
on the left.

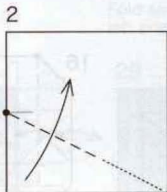

Crease on the left.

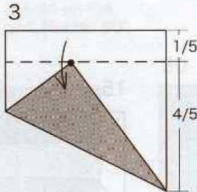

The paper is  
divided into fifths.

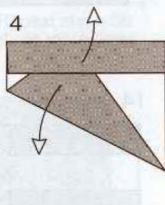

Unfold and rotate.

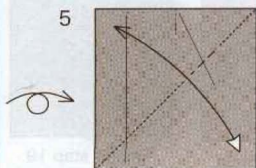

Fold and unfold  
by the intersection.

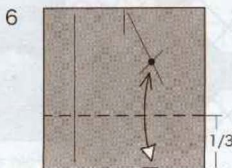

Fold and unfold.

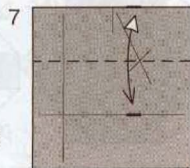

Fold and unfold.

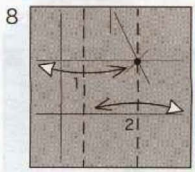

Fold and unfold.

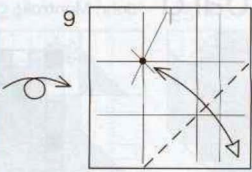

Fold and unfold.

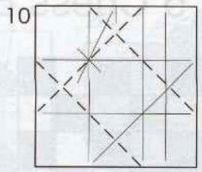

Fold and unfold three more times.

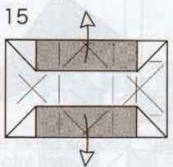
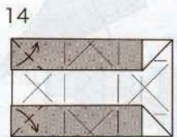
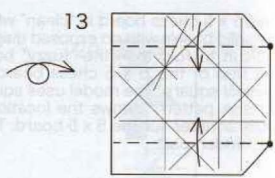
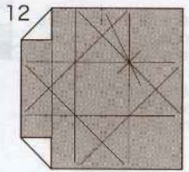
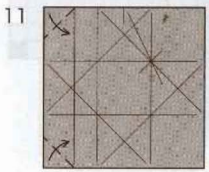

Unfold.

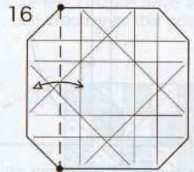

Fold and unfold.

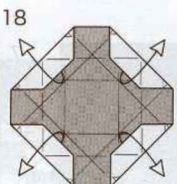
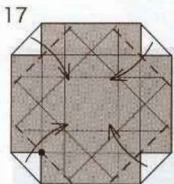

Unfold.

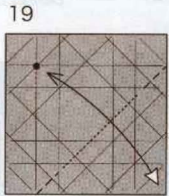

Fold and unfold.



Repeat step 19 three more times.



21

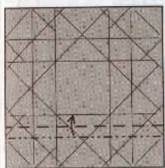

Mountain-fold along the crease.

22

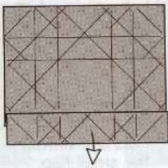

Unfold.

23

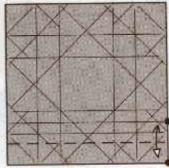

Fold and unfold.

24

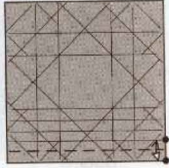

Fold and unfold.  
Rotate 90°.

25

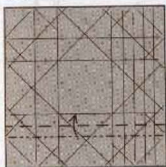

Repeat steps 21-24 three more times.

26

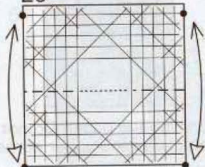

Fold and unfold on the left and right. Rotate 90°.

27

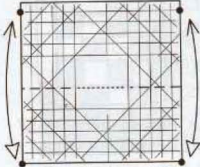

Repeat steps 26 three more times.

28

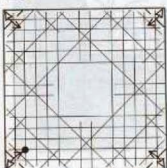

Fold and unfold.

29

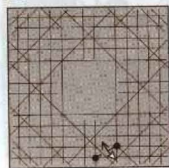

Fold and unfold.

30

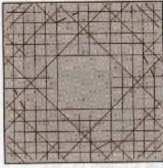

Repeat steps 29 three more times. Rotate.

31

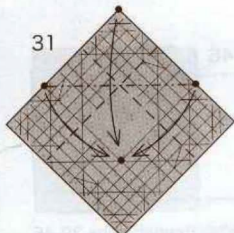

Collapse along the creases. This is similar to making a preliminary fold. The dots will meet.

32

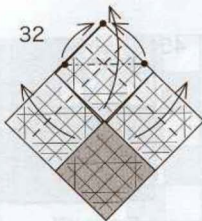

33

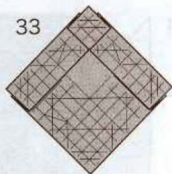

Repeat steps 31-32 three more times. You will have to unfold each unit and refold as you repeat these folds.

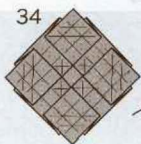

34

Rotate.

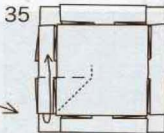

35

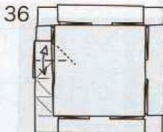

36

Fold and unfold the small flap.

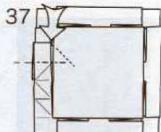

37

Sink. Do this carefully so as not to rip the paper. Rotate 90°.

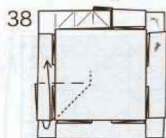

38

Repeat steps 35-37 three more times.

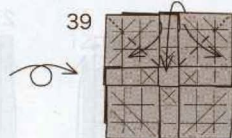

39

Spread the paper. Do not crease at the upper corners.

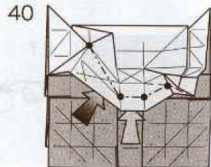

40

The model is 3D. Puff out at the dots.

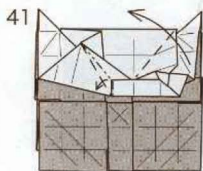

41

The model is 3D. Flatten.

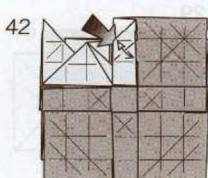

42

Fold and unfold the top layers.

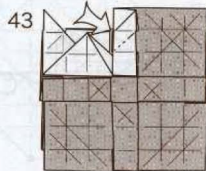

43

Push in, carefully so as not to rip the paper.

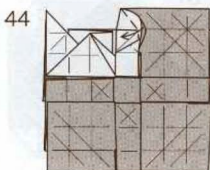

44

The model is 3D. Flatten.

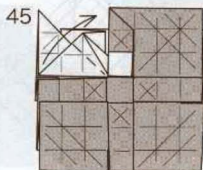

45

Rotate 90°.

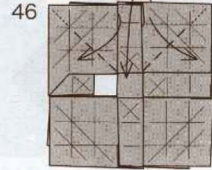

46

Repeat steps 39-45 three more times.

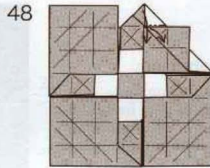
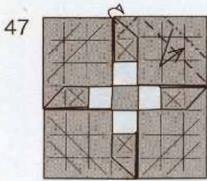

Squash-fold.

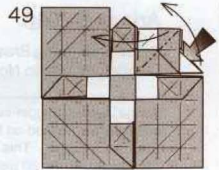

Squash-fold.

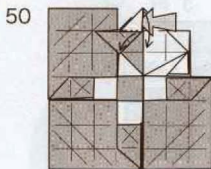

Squash-fold.

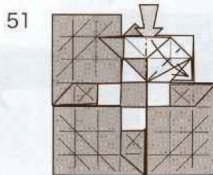

Squash-fold. Rotate 90°.

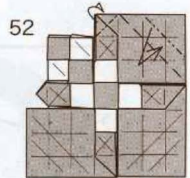

Repeat steps 47-51 three more times.

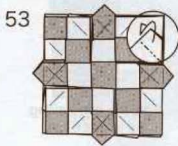

Fold the inside layers together to lock the model.

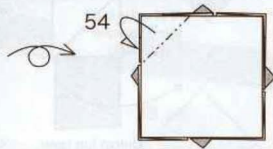

Wrap around the hidden folds, from step 53.

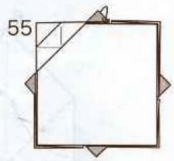

Tuck inside.

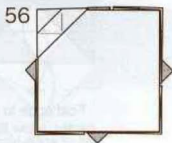

Repeat steps 53-55 three more times.

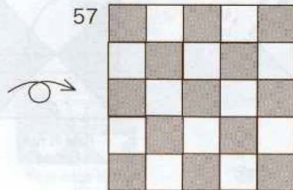

5 x 5 Chess Board

## Adaga ©2010

By Isa Klein (MG, Brasil)

Diagram by Márcio Noguchi (NY, USA)

"Adaga" means dagger in Portuguese. The name of this model is given based on the shape of the details, that looks like a dagger. This model works best with a double sided paper. Using 30 pieces of 7.5cm x 7.5cm it results in model of about 10-12 cm of diameter. Several variations are possible (presented at the end).

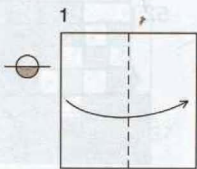

1 Start white side up. Fold in half.



2 Fold the edge along the folded edge.



3 Turn over, top to bottom.



4 Fold the edge along the folded edge.

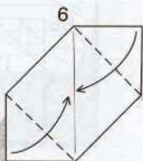

6 Fold the corners to the center.



5 Unfold top layer.



7 Rotate 45°.

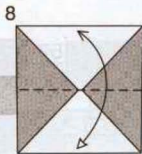

8 Fold in half. Unfold.

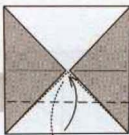

9 Fold edge to the center, allow flap to flip out.



21

Adaga unit  
complete.

20



Fold corners down.

19



Fold in half.

18



Inside reverse.

17

Fold and unfold  
angle bisector.

16

Fold edge to the  
crease (angle  
bisector).

15

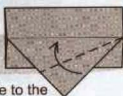
Fold edge to the  
crease (angle  
bisector).

14

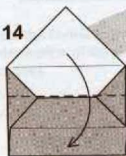
Valley fold on  
existing crease.

13

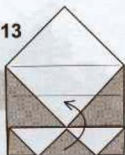
Unfold one  
layer.

12

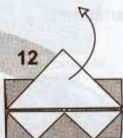
Unfold the  
top layer

10

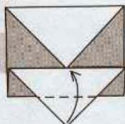
Fold edge to the  
center.

11

Fold edge to the  
center, allow flap to  
flip out.

## Assembly:

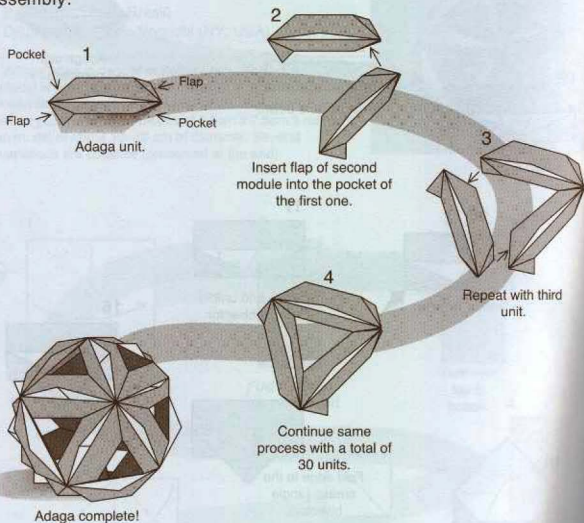

## Variations:

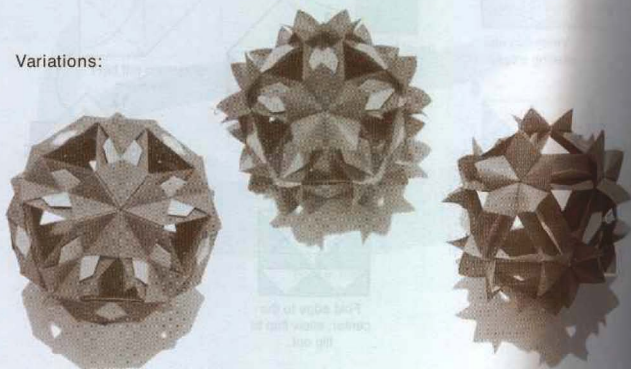

## Chloe's Star © 2008

Designed by: Bill Reyes (NJ, USA)

Diagrammed by: Márcio Noguchi (NY, USA)

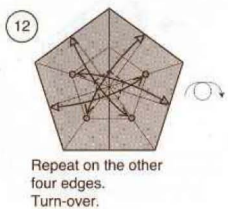
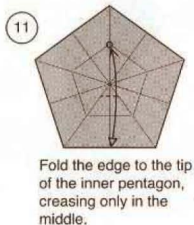
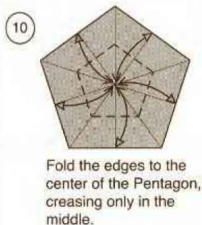
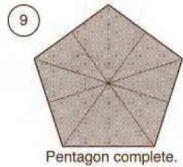
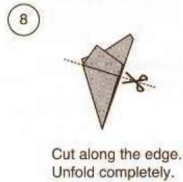
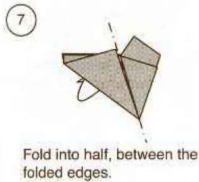
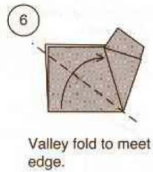
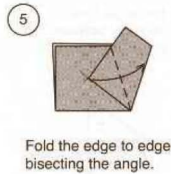
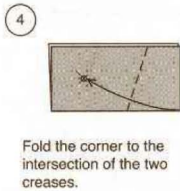
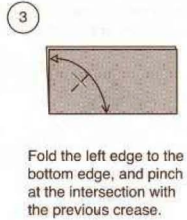
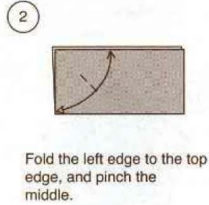
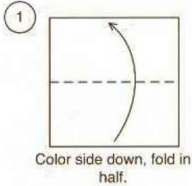
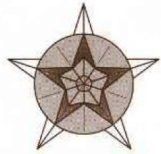

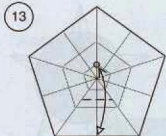

13 Fold the edge to the tip of the innermost pentagon, creasing only in the middle.

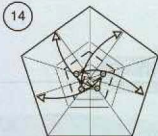

14 Repeat on the other four edges.

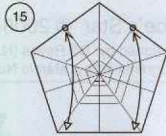

15 Fold the edge to the points indicated, creasing only in the middle.

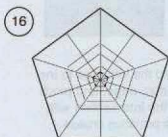

16 Repeat on the other four edges. Turn over.

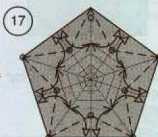

17 Fold the angle bisector, creasing only between the center line. Turn over.

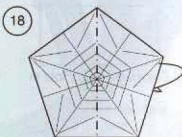

18 Mountain fold, in half.

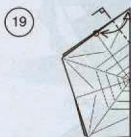

19 Fold and unfold between the mark (intersection point of the crease with the folded edge) and the edge at right angle.

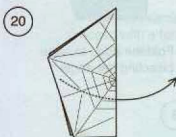

20 Unfold back to the same position of step 18.

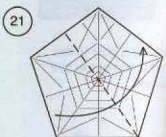

21 Fold in half, keeping the last crease exposed on the top.

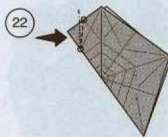

22 Reverse fold between the marks (intersection of the crease and the edge)

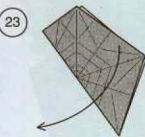

23 Unfold to the same position as of step 21.

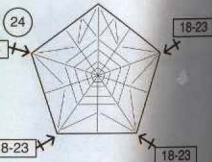

24 Repeat steps 18 to 23 on the remaining four corners.



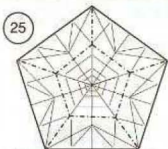

25

Start the collapse by first creating a pentagonal "table". Pinch mountain folds using existing creases.

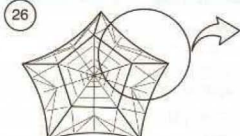

26

Collapse in progress. Model will not lie flat. Continue pinching from the outside to inside. See details on next step.

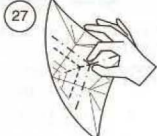

27

Pinch according to the picture.

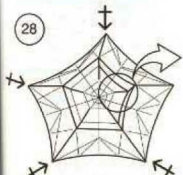

28

Repeat on the remaining four corners.

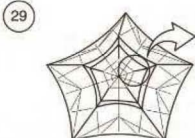

29

Continue collapsing. See next step for details.



30

Pinch according to the picture.

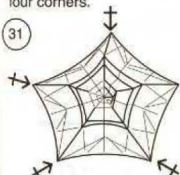

31

Repeat on the remaining four corners.

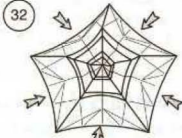

32

Complete collapse. Shape the model into a star by reinforcing the creases.

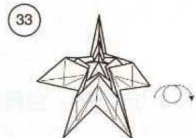

33

Turn over.

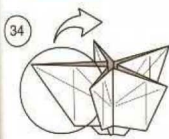

34

Magnified view of one flap.

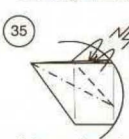

35

Crimp, using existing creases on both the front and back layers.

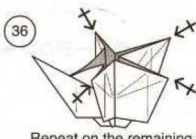

36

Repeat on the remaining four corners, making sure that you hold each crimp in place. The paper in the center will make the model become 3D.

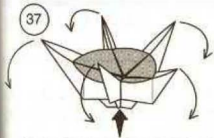

37

Carefully push the bottom, pop the model, and spread all the points to the side, exposing the inside.

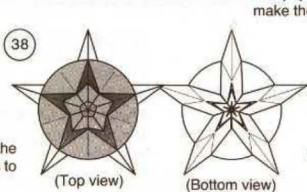

38

(Top view)

(Bottom view)

Chloe's Star complete.

# 雑誌『折紙探偵団』年間購読のご案内

雑誌『折紙探偵団』は日本折紙学会の機関誌です。隔月刊(奇数月25日発行)で年6回発行されます。年間購読制です(ばら売りは行っておりません)。

- 申込方法**
1. 郵便振替にてご送金下さい(普通の振替用紙でお申込み頂けます)。
  2. 振替用紙の「通信欄」に下記必要事項をご記入下さい。

**第21期(2010年4月～2011年3月/121～126号)**

年間購読費 **3,800円**(税、送料込み)

形変わりに料金が変更になる場合があります。2010年4月以降は事務局にお問い合わせください。

口座名 **日本折紙学会**

振替口座番号 **00170-7-260699**



雑誌『折紙探偵団』122号表紙  
表紙フルカラー/本文38ページ  
(カラー口絵2ページ含む)

**記入必要事項** 1～3は必ずお書き下さい。

1. 住所
2. 氏名 ※ふりがなをお願いします。
3. 電話、FAX番号
4. E-Mailアドレス
5. 性別
6. 生年月日
7. 職業

**■バックナンバー購入について**

現在11期～20期を取り扱っております。購入ご希望の場合は、「通信欄」のところへ希望する期を明記の上、相当金額をお振り込み下さい。

11期(61～66号)・12期(67～72号)・13期(73～78号)・14期(79～84号)・  
15期(85～90号)・16期(91～96号)・17期(97～102号)・18期(103～108号)・  
19期(109～114号)・20期(115～120号)

**■雑誌『折紙探偵団』について**

- ・『折紙探偵団』は日本折紙学会の機関誌です。購読には学会会員である必要はありません。
- ・隔月刊(奇数月25日発行)で年6回発行されます。
- ・年間購読のみ受け付けています。ばら売りは行っておりません。
- ・海外発送をご希望の場合は料金が異なります。事務局へお問い合わせください。
- ・折り図・展開図・折り紙研究・エッセイ・最新情報など充実の誌面です。

(税込送料込み)  
1期3,800円

## 日本折紙学会 会員募集のお知らせ

日本折紙学会では、随時会員を募集しております。申込方法は定期購読と同じです。

会費には21期定期購読料も含まれています(すでに21期を購読されている方は4,600円となります)。

**第21期会費 8,400円** ※通信欄に「第21期会費」と明記してください

日本折紙学会事務局(10:00～18:00 日祝休) 〒113-0001 東京都文京区白山 1-33-8-216  
Phone/Fax 03-5684-6080 日本折紙学会ホームページ <http://www.origami.gr.jp/>

## ギャラリーおりがみはうすのご案内 〒113-0001 東京都文京区白山1-33-8-216

- 1989年にオープンした、日本最初 営業日/月曜～金曜 12:00～15:00  
の折り紙作品専門ギャラリー。公開時 /土曜・日曜・祭日 10:00～18:00  
間は右記の通りです。 定休日/なし(公開時間は変更される可能性があります。下記にてご確認ください)

ホームページ = <http://www.origamihouse.jp/> e-mail = [info@origamihouse.jp](mailto:info@origamihouse.jp)

## 第16回 折紙探偵団コンベンション折り図集

PRINTED IN JAPAN

2010年8月13日発行

著者/日本折紙学会

発行人/西川誠司

編集人/山口 真

編集スタッフ/神谷哲史・勝田恭平・水野健

デザイン/おりがみはうす

発売元/おりがみはうす

発行所/日本折紙学会

113-0001

東京都文京区白山 1-33-8-216 (ギャラリーおりがみはうす内)

Phone & Fax 03-5684-6080 (10:00～18:00/日・祭日休)

E-mail = [webman@origami.gr.jp](mailto:webman@origami.gr.jp)

Web Site = <http://www.origami.gr.jp/>

■Origami Tanteidan Convention Book vol.16 / Published on 13, August 2010 by Japan Origami Academic Society, 1-33-8-216 Hakuon Bunkyo-ko  
113-0001 Tokyo JAPAN / Publisher: Nishikawa Seiji / Editor in Chief: Yamaguchi Minkoto / Editorial Design: OrigamiHouse

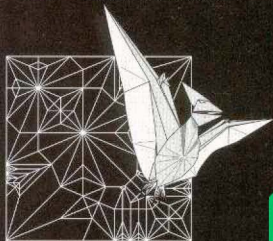

© Kawahata Fumiaki

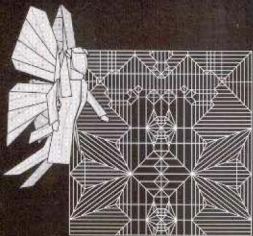

© Jason Ku

## Japão Burajirujin

[www.japaoburajirujin.blogspot.com](http://www.japaoburajirujin.blogspot.com)



© Brian Chan

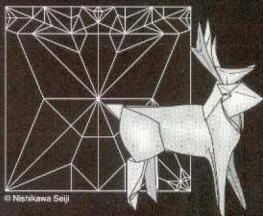

© Nishikawa Seiji

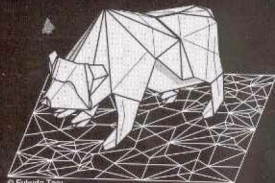

© Fukuda Toru

定価 2,000円