

ORIGAMI TANTEIDAN 14th CONVENTION

第14回
折紙探偵団
コンベンション

Japão Burajirujin

www.japaoburajirujin.blogspot.com

© Sipro Mabona

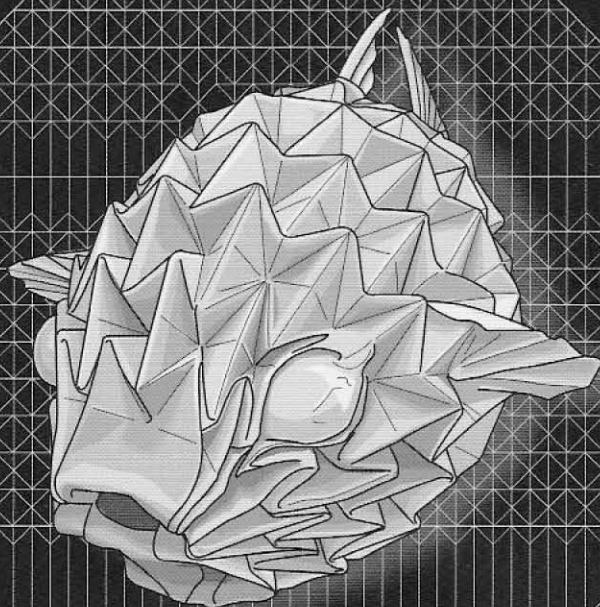

Japão Burajirujin

www.japaoburajirujin.blogspot.com

折り図集

Vol.14

発行・日本折紙学会

14th Origami Tanteidan Convention

第14回
折紙探偵団
コンベンション

Japão Burajirujin

www.japaoburajirujin.blogspot.com

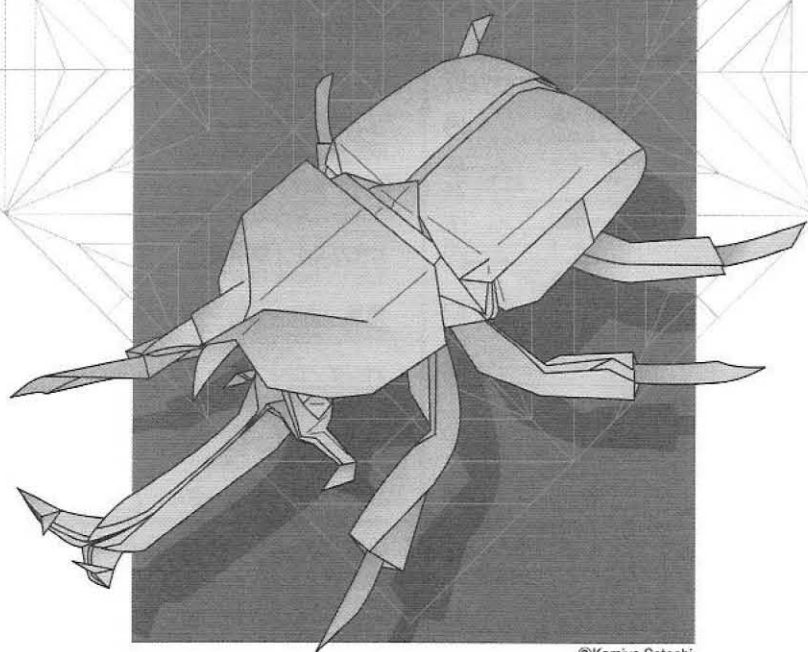

©Kamiya Satoshi

折り図集

.....
Vol.14

発行・日本折紙学会

CONTENTS

折り図記号 Symbols for Folding 3

基本形・沈め折り Preliminary Bases and Sink 4

国内編:Models by Japanese Folders

スター・チェンバー / 川村みゆき STAR CHAMBER Kawamura Miyuki	6
キューブリック / 川村みゆき CUBRICK Kawamura Miyuki	8
スターダスト・ブロック / 霞 誠志 Stardust Block Kasumi Seishi	10
花のトートバッグ / 市川 学 Tote bag of flower Ichikawa Manabu	16
六角からの花重ね / 布施知子 Hexagonal Flower Layers	19
F-22A ラプター / 青木 良 F-22A Raptor Aoki Ryo	22
フェニックス / 山下 明 Phoenix Yamashita Akira	28
サンタクロース / 照井貞一郎 Santa Claus Terui Teiichiro	29
金魚すくあ / 霞 誠志 GoldFish Type Square Kasumi Seishi	34
リス 22.5 / 前川 淳 Square Squirrel 22.5 Maekawa Jun	38
ねずみ / 中井 努 Mouse Nakai Tsutomu	42
なかよしキツネ / 津田良夫 Playing foxes Tsuda Yoshio	46
イルカ / 田中正彦 Dolphin Tanaka Masahiko	50
カンガルー / 萩原 元 Kangaroo Hagiwara Gen	54
ネコ-15° 2007 / 西川誠司 15°-Cat 2007 Nishikawa Seiji	60
狼 / 宮島 登 Wolf Miyajima Noboru	65
猫君 / 川畑文昭 CAT HERR Kawahata Fumiaki	74
アゲハチョウ / 目黒俊幸 Swallowtail Butterfly Meguro Toshiyuki	86
カブトムシ2.1 / 神谷哲史 Samurai Hermet Beetle 2.1 Kamiya Satoshi	100
ミヤマクワガタ / 北條高史 Lucanus stag beetle Hojyo Takashi	118

海外編:Models by Foreign Folders

バンブー・スター / ヘルマン・バン・グーベルジャン BAMBOO STAR Herman Van Goubergen	139
カーラー・ユニット / ヘルマン・バン・グーベルジャン CURLER UNITS Herman Van Goubergen	140
チャイ・モジュラー / ヘルマン・バン・グーベルジャン CHI MODULAR Herman Van Goubergen	142
ウォーリー・ロボット / ブライアン・チャン Wall-E robot Brian Chan	145
トランペット / オ・ギュソク Trumpet Oh, Kyu-Seok	146
ティータイム / マーク・カーシェンバウム Tee Time Marc Kirschenbaum	150
フグ / シッポ・マボナ FUGU Siphon Mabona	157
コイ / シッポ・マボナ KOI Siphon Mabona	166
イカ / アレッサンドロ・ベバー SEPIA Alessandro Beber	170
ヒキガエル / 陳漢輝 Toad Jacky Chan	174
白鳥 / ホアン・ティン・クエット Swan Hoang Tien Quyet	178
パンダ / ロマン・ディアス PANDA Roman Diaz	180
カバ / スティーブ・ケイシー Hippo Steven Casey	182
熊2 / ジャレッド・ニードル Bear 2 Jared Needle	186
馬 / クエンティン・トロリップ Horse Quentin Trollip	192
オラウータン / クエンティン・トロリップ Orang Utan Quentin Trollip	202
悪魔の面 / ロマン・ディアス Devil's Mask Roman Diaz	213
グリフォン / アンドレイ・エルマコフ Gryphon Andrey Ermakov	218
ヒッポグリフ / マヌエル・シルゴ Hippogriff Manuel Sirgo	228
ウルティモ・ドラゴン / フェルナンド・ヒルガド El ultimo dragon Fernando Gilgado	238
クワガタムシ・メス / ニコラ・ガハルド・エンリケス Lucanus Hembra Nicolas Gajardo Henriquez	247

Japão Burajirujin

www.japaoburajirujin.blogspot.com

折り図記号 Symbols for Folding

折り線の種類 Types of crease lines

谷折り線 Valley fold



谷折り
Valley fold

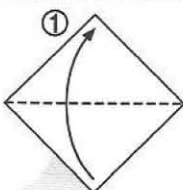

山折り線
Mountain fold



山折り
Mountain fold

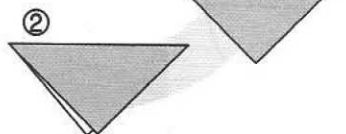

折り方の技法 Basic Folding Skills

中わり折り Inside-reverse fold

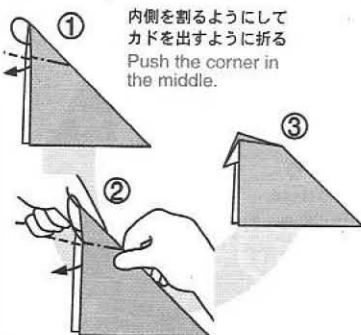

かぶせ折り Outside-reverse fold

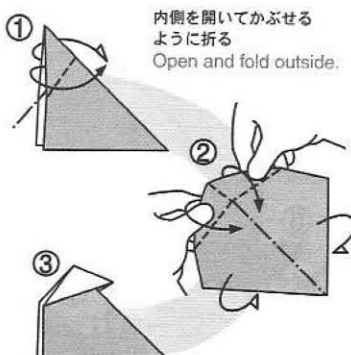

内側をひろげてつぶすように折る
Squash fold

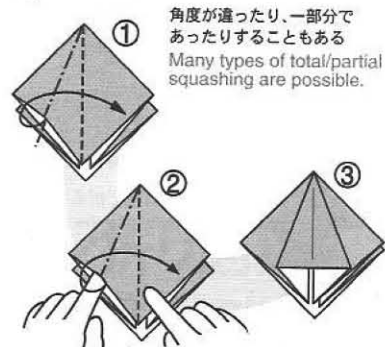

いろいろな記号 Symbols

折り筋をつける
Making a crease line

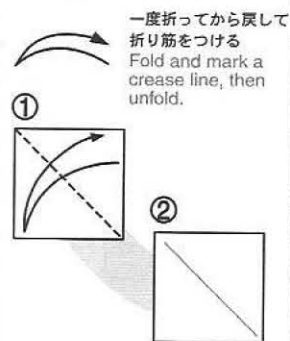

裏返す Turn paper over

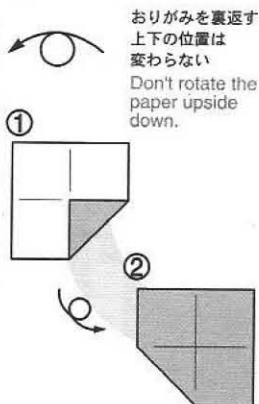

段折り Pleat fold

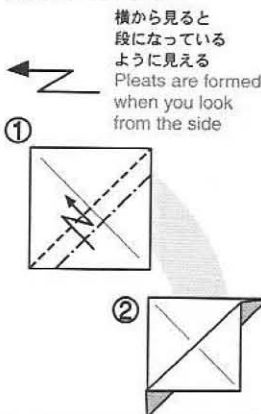

下の部分を出すように折る
Release bottom flap when making a fold

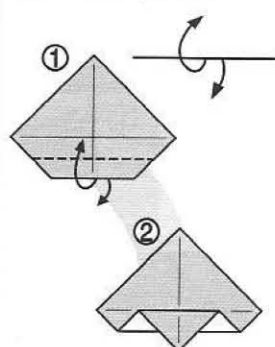

次の図が大きくなる
A magnified view

仮想線・透視線
A hidden line

押す・つぶす
Push paper in

引き出す
Pull out

ひろげる Open up

○と○を
合わせて折る
Match circled points

巻くように折る
Roll the flap by repeated folds

注意するところ
Marked points

次の図の見位置が変わる
Paper position changes (rotation)

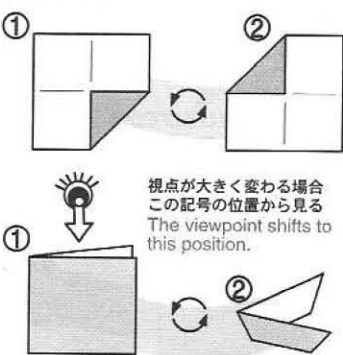

等分記号 Division

長さの等分 Dividing the length

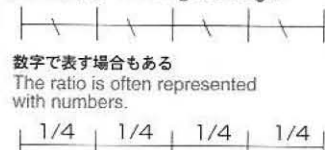

角度の等分
Dividing the angle

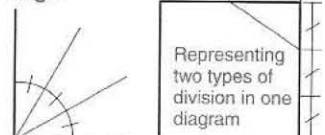

基本形 / 沈め折り Preliminary Bases and Sink

基本形 Preliminary bases

風船基本形 Water Bomb Base

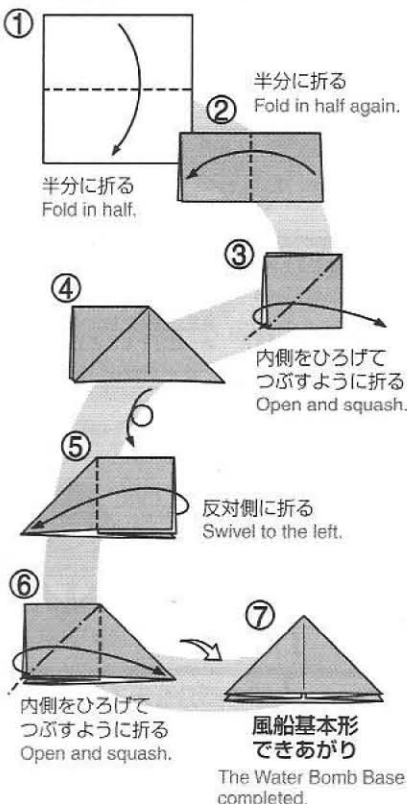

正方基本形と鶴の基本形 Preliminary Base / Bird Base

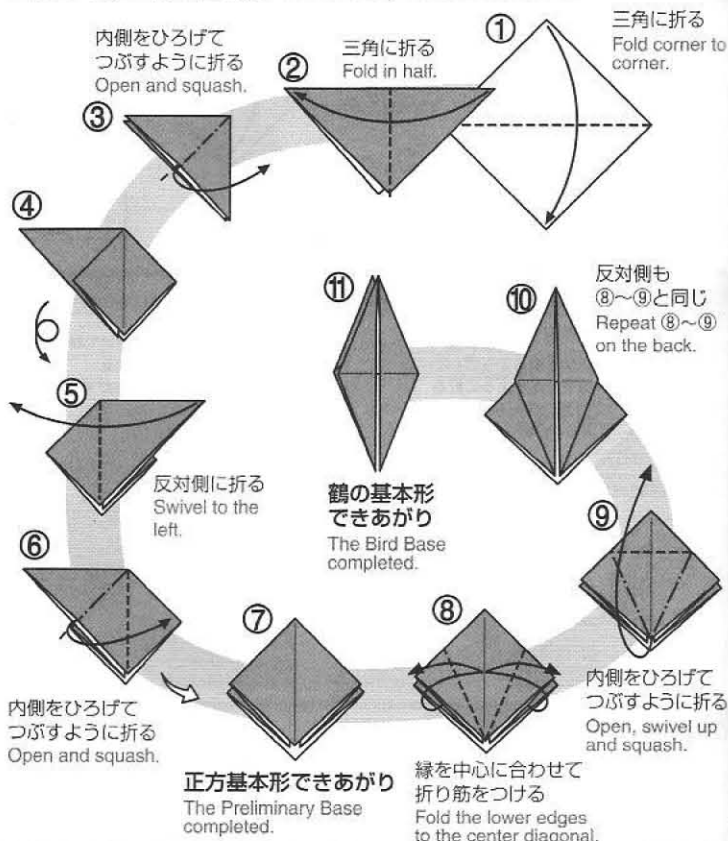

沈め折り Open sink / Closed sink

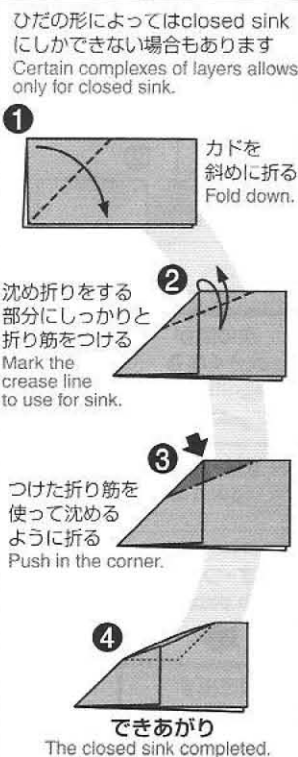
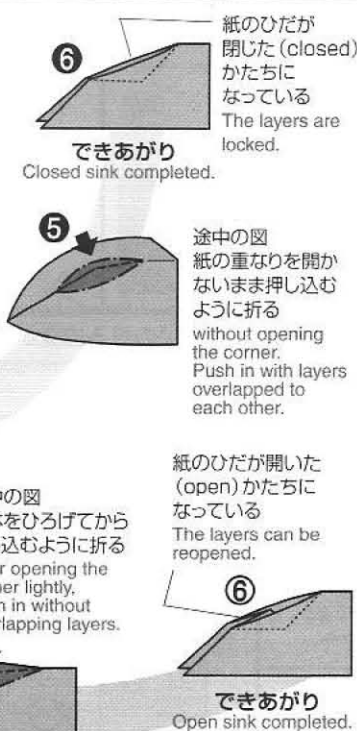
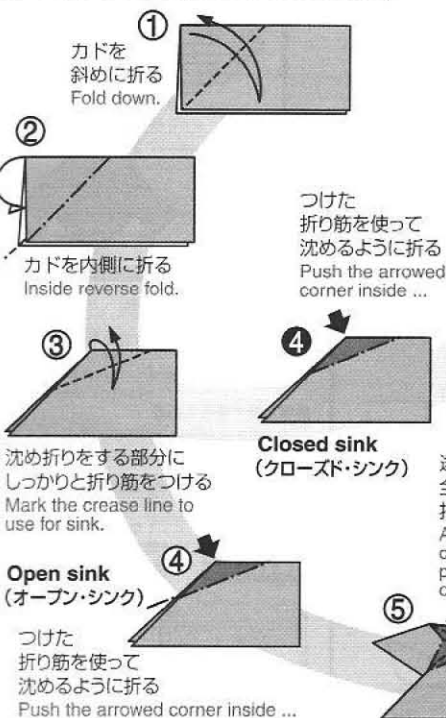

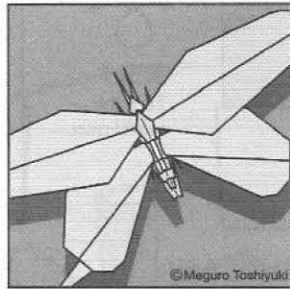
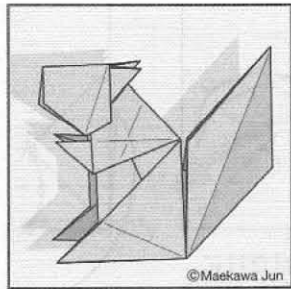

第14回折紙探偵団コンベンション折り図集 14th Origami Tanteidan Convention Book

国内編 / Models by Japanese Folders P.6

海外編 / Models by Foreign Folders P.139

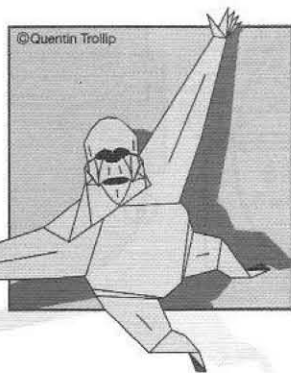
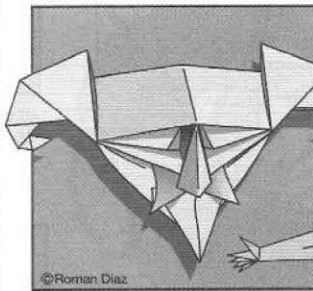
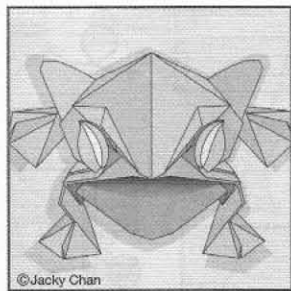

スター・チェンバー

STAR CHAMBER

© 2008 Miyuki Kawamura / 川村みゆき

円筒ケ形のカーブを綺麗につけてください。違う長さの用紙を混ぜて組むこともできます。色々試してみてください。

Make clear the curves of cylinders. You can use any length of paper in one model together.

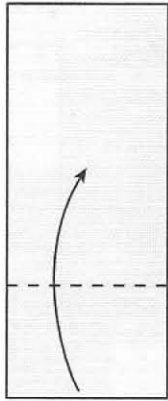

①

1 : 3/2 より長い長方形を使います。適当な位置で折り上げる。
1 : 3/2 or more long shape rectangle. Fold up on an arbitrary ratio.

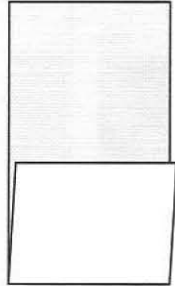

②

色のついた部分が正方形に近いと仕上がりが綺麗です。To make a good style model, make colored part a square shape.



裏返す
Turn the model over.

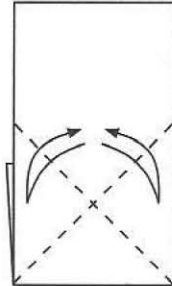

③

1枚目だけに折り目をつける。Fold only upper layer and unfold.

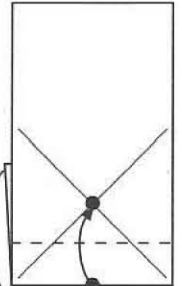

④

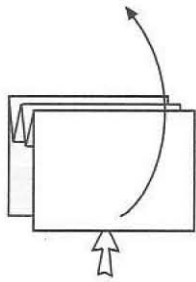

⑨

中央から開く。
Open the center.

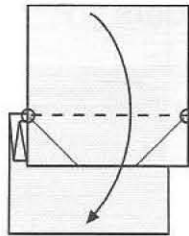

⑧

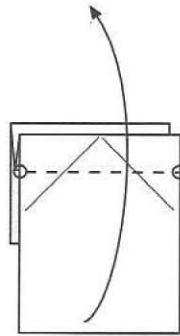

⑦

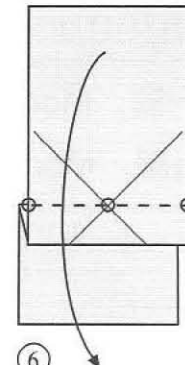

⑥

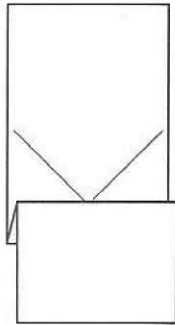

⑤

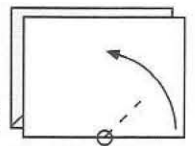

⑭

1枚目だけ折る
Fold only upper layer.

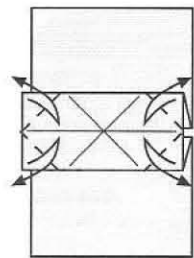

⑩

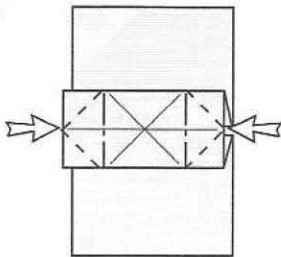

⑪

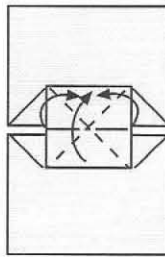

⑫

風船の基礎のようにたたむ
Make a water bomb base.

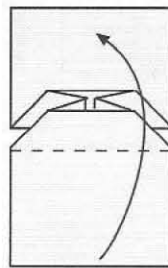

⑬

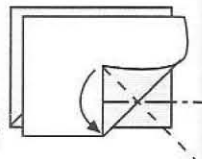

⑮

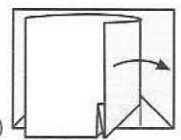

⑯

開く
Unfold

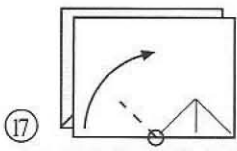

⑰ 4つの角すべてに同様に折り目をつける。
Do the same on the all corners.

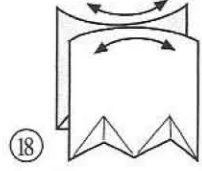

⑱ 綺麗にカーブをつける
Make clear the two curves.

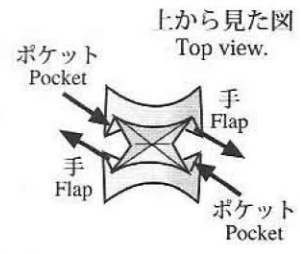

Japão Burajirujin
www.japaoburajirujin.blogspot.com

「スター・チェンバー」のユニット
The module of STAR CHAMBER
同じものを 30 枚作ります。
You need 30 modules.

組み方 / Assembly

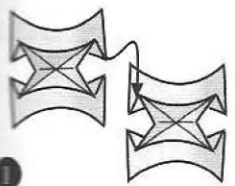

① 手をポケットに差し込む
Tuck the flap into the pocket.



12 枚組
12 modules

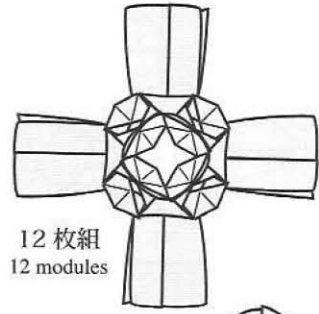

12 枚組
12 modules



④ 五角形を作る
Make a pentagon.

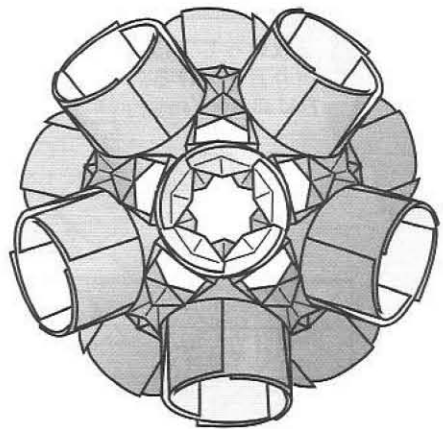

「スター・チェンバー」
STAR CHAMBER
30 枚組 / modulers

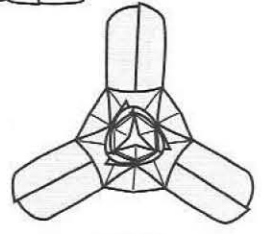

6 枚組
6 modules

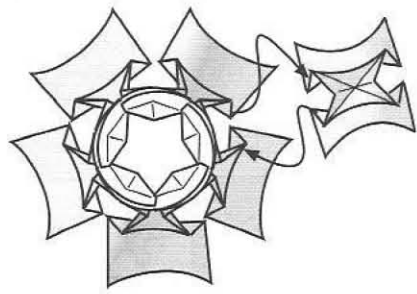

⑤ 三角形を作る。
残りのユニットも同じように組んでいく。
Make a triangle.
Insert the other modules in the same way.

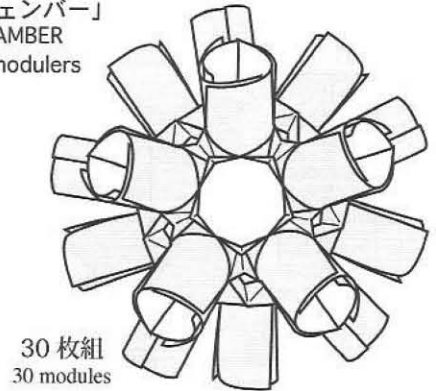

30 枚組
30 modules

キューブリック

CUBRICK

© 2008 Miyuki Kawamura / 川村みゆき

軽いですが、かなり丈夫に仕上がります。応用作品の「クオラ」はハコガメという意味です。

The model of CUBRICK is very light but pretty strong. "CUORA" means a box turtle.

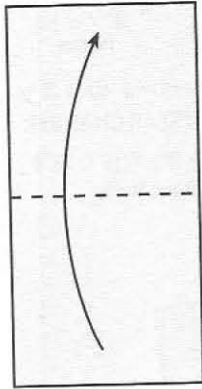

① 1 : 2 の長方形より
1:2 rectangle

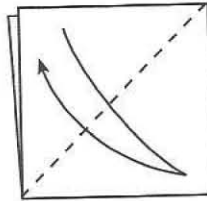

② 1枚目だけに折り目をつける。裏も同じ。
Fold only upper layer and unfold. Do the same on the opposite side.

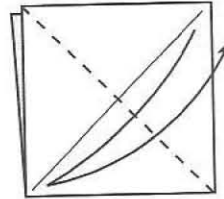

③ 1枚目だけに折り目をつける。裏も同じ。
Fold only upper layer and unfold. Do the same on the opposite side.

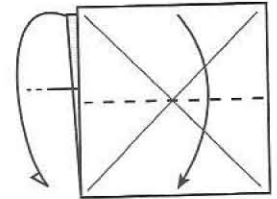

④

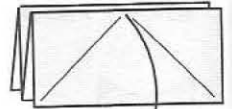

⑤ 真ん中を開く
Unfold the center.

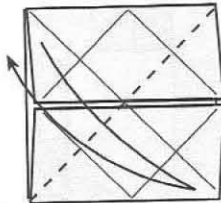

⑧ 2枚いっしょに折り目をつける。
Fold all layers and unfold.

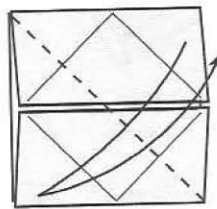

⑦ 2枚いっしょに折り目をつける。
Fold all layers and unfold.

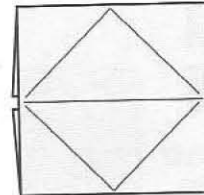

⑥ 裏返す
Turn the model over.

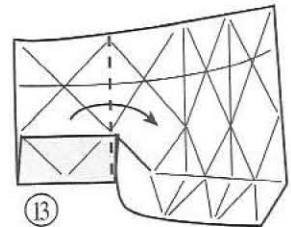

⑬

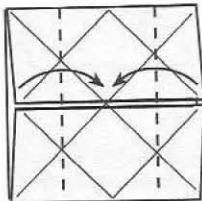

⑨

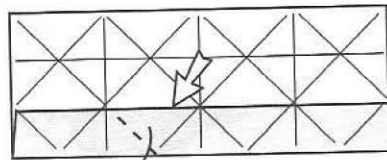

⑫ 右下を開きながら立ち上げるように折る。
Open and fold up the right side.

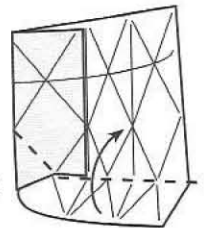

⑭

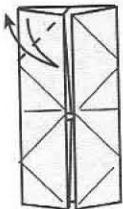

⑩ 4つの角すべてに折り目をつける。
Fold and unfold. Do the same on the all corners.

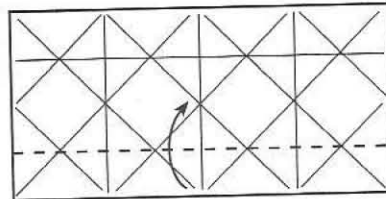

⑪ いったん開いてから折り上げる。
Open the model and fold.

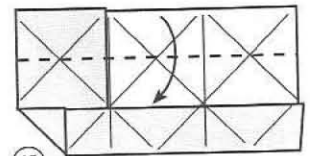

⑮

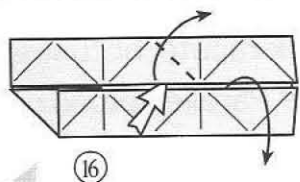

16

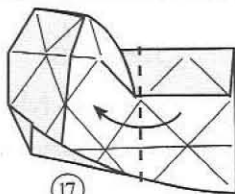

17

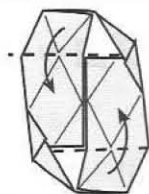

18 平らにたたむ
Make the model flat.

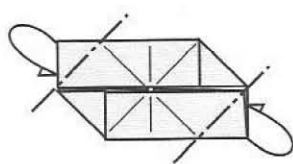

19 中割り折り
Inside revers fold.

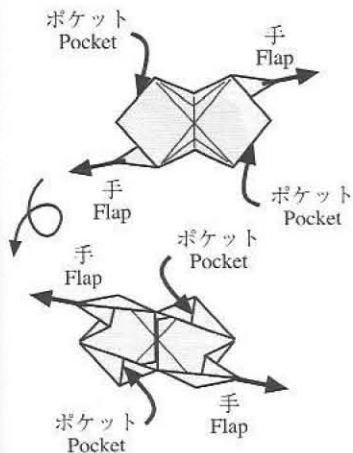

「キューブリック」のユニット
The module of CUBRICK
同じものを 30 枚作ります。
You need 30 modules.

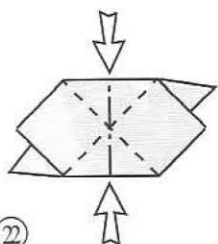

22 横腹を押して立体的にする
Push the sides and make the model 3D.

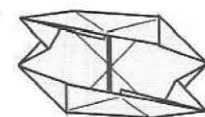

21 裏返す
Turn the model over.

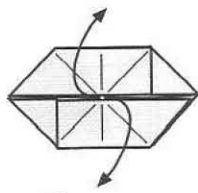

20 少し開く
Open a bit.

応用「クオラ / CUORA」

工程①と、⑦、⑧の折り目をつけない。

Don't fold the step ①, ⑦ and ⑧.

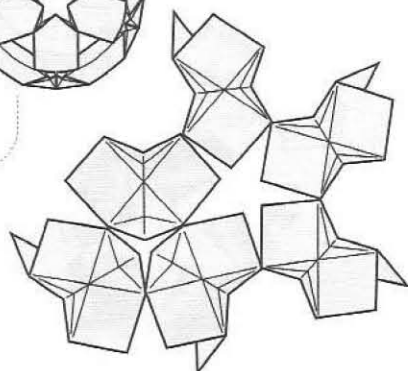
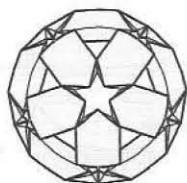

5 残りのユニットも同じように組んでいく。
Insert the other modules in the same way.

組み方 / Assembly

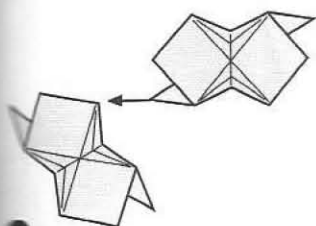

1 手をポケットに差し込む
Tuck the flap into the pocket.

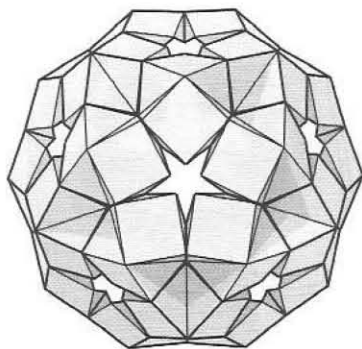

「キューブリック」
CUBRICK
30 枚組 / modulers

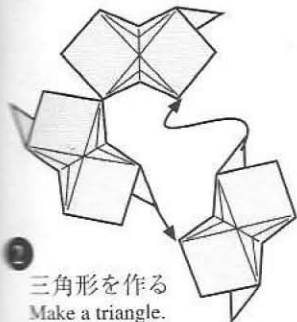

2 三角形を作る
Make a triangle.

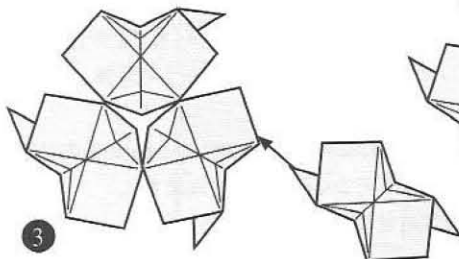

3

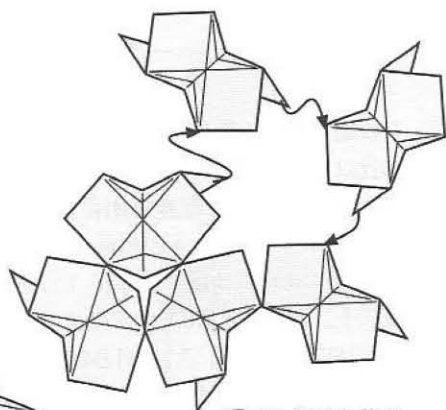

4 五角形を作る
Make a pentagon.

～スターダスト・ブロック～

Stardust Block«acute·obtuse»

『Dual Module Parallelepiped』

2007/11 作／霞誠志

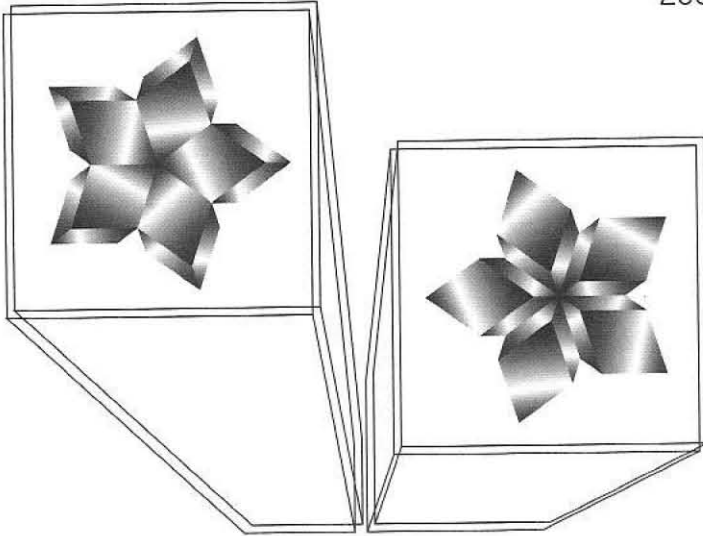

Type:acute-72

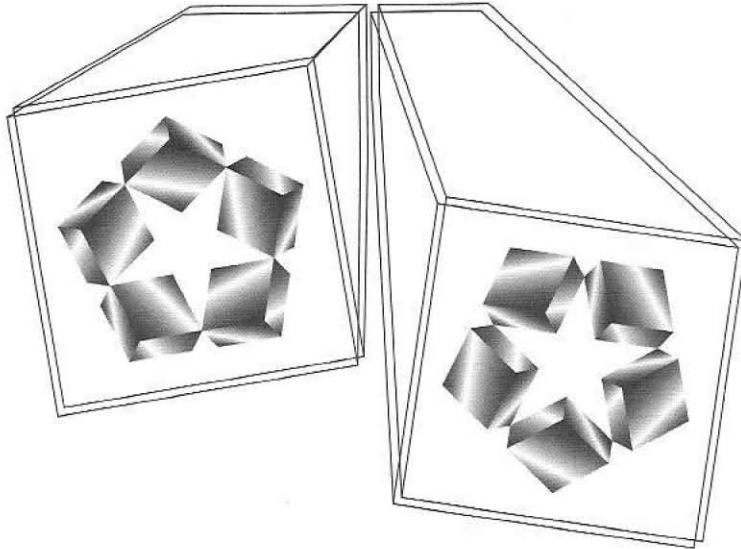
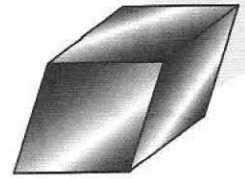

Type:obtuse-72

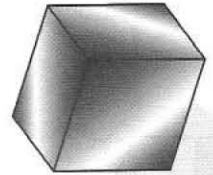

2枚組の平行六面体です。今回の作品を構成しているひし形の角度は、鋭角 72° 、鈍角 108° （短対角線：長対角線の比は $1:1.376$ ）になっていますので、5個並べると星型や五角形が出来ます。

ひし形の比率はある程度自由に選べるので別のタイプのスターダスト・ブロックをつくることも出来ます。（Type:acute-72とType:obtuse-72の展開図を応用すればつくる事が出来ますので試してみてください）

例えば、ひし形の対角線の比率が $1:\sqrt{2}$ のいわゆる白銀比の平行六面体。このタイプはobtuseを4つ組み合わせて菱形十二面体にする事が出来ます。

また、対角線の比率を $1:1.618$ の黄金比にした場合はacute·obtuseを各2個ずつ組み合わせると菱形十二面体、各5個ずつ組み合わせると菱形二十面体をつくることも出来ます。

（どうやって組み合わせたブロックを安定させるかが問題ですが・・・）

1. 折り筋を付ける

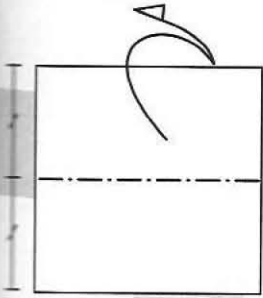

2. ●印を合わせて○印の部分にだけ折り筋を付ける

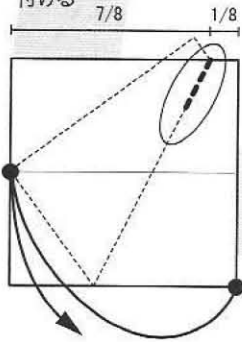

5. カドを折り筋に合わせて折る

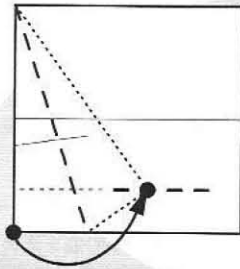

6. 半分に折る

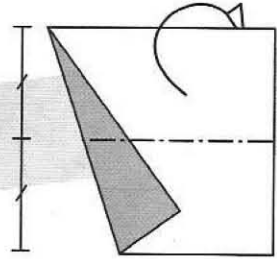

4. ●印を合わせて折り筋を付ける

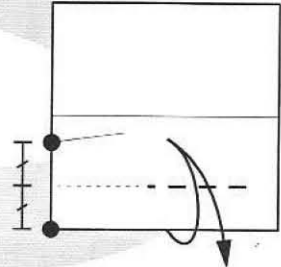

3. ●印を合わせて折り筋を付ける

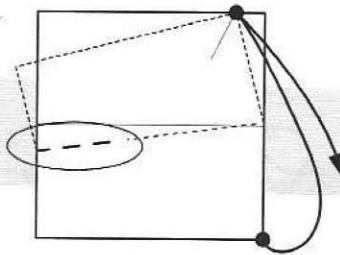

2. ○印を通る線で折る

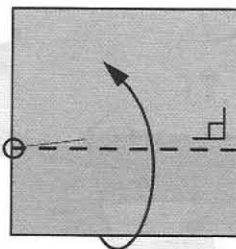

5. 手前の縁に合わせてうしろに折る

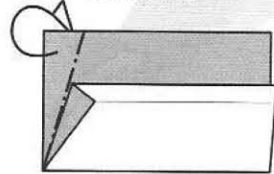

1. ●印を合わせて○印の部分にだけ折り筋を付ける

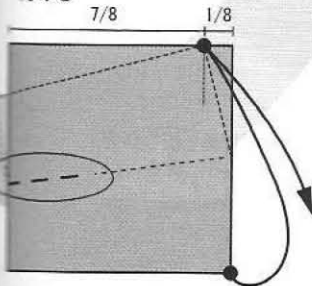

3. 紙を重ねたまま半分に折って折り筋を付ける(内側の紙がずれないように注意)

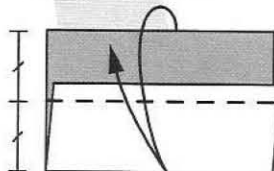

4. カドを折り筋に合わせて折る

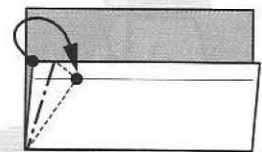

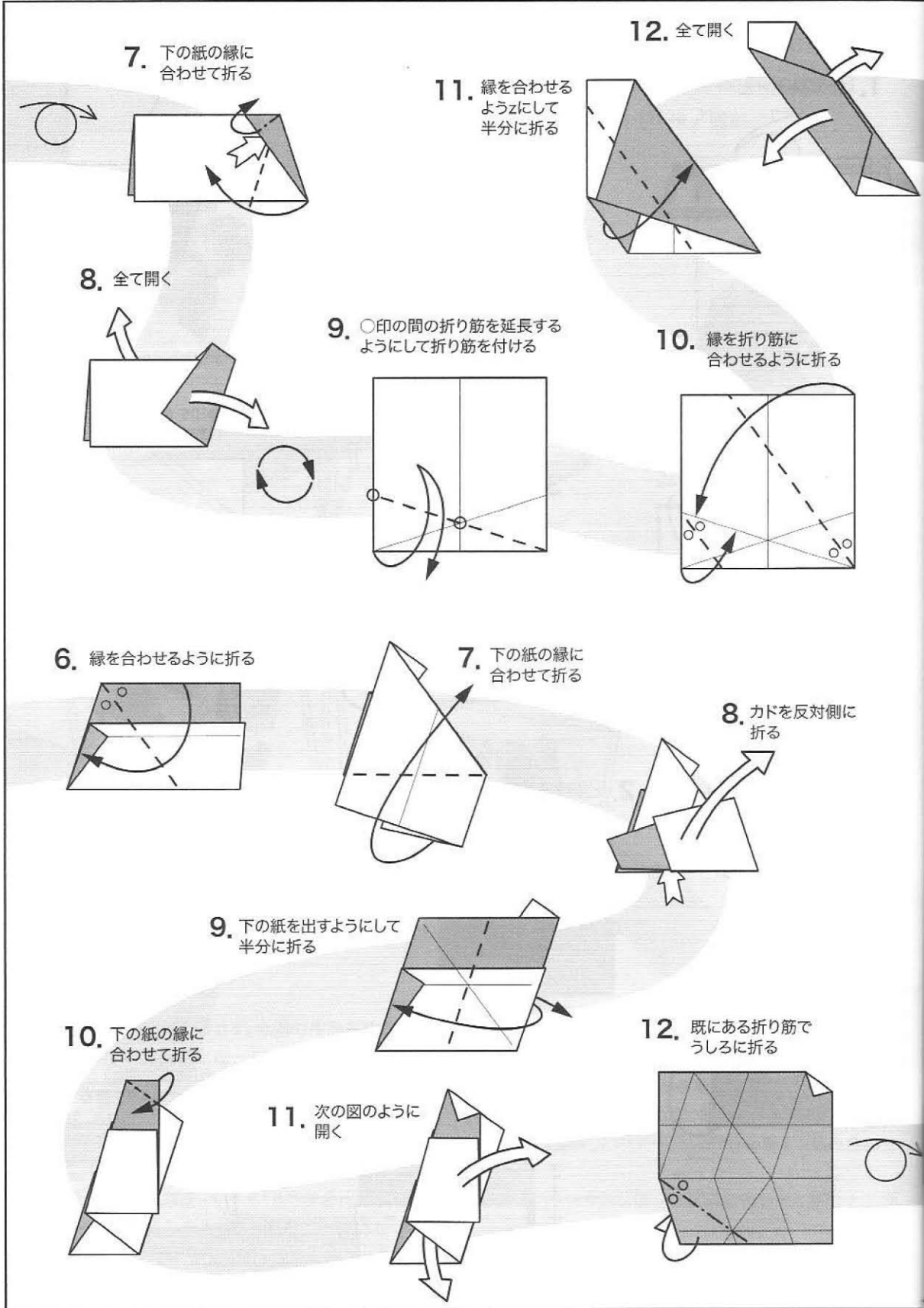

13. 反対側も「10~12」と同じように折って折り筋を付ける

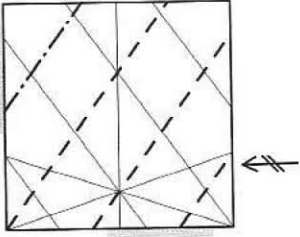

16. 反対側も「14~15」と同じように折って折り筋を付ける

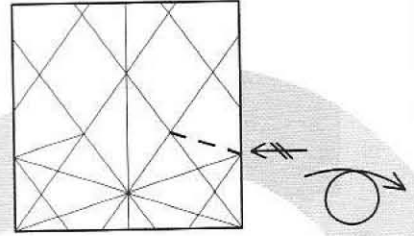

15. (既にある折り筋を利用して) 折り筋を付けたら全て開く

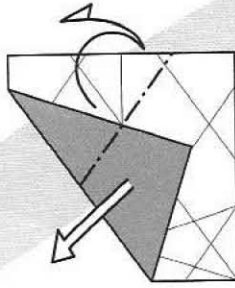

14. 既にある折り筋で折る

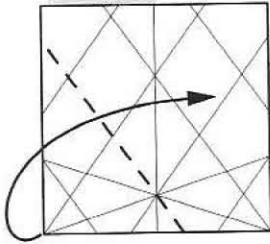

15. 既にある折り筋で折る

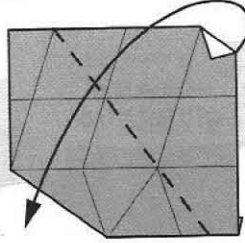

16. 下の紙の縁に合わせて (かぶせ折りのように) 折る

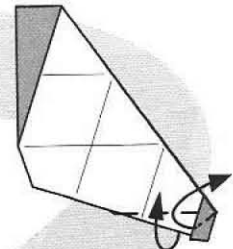

14. 既にある折り筋で折る

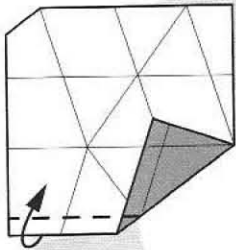

17. 次の図のように開く

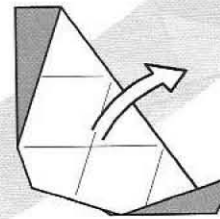

13. 下の紙を引き出す

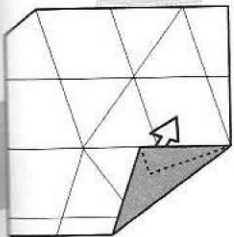

18. 既にある折り筋で折る

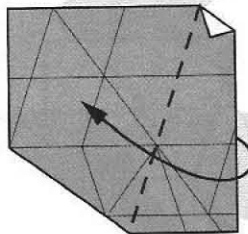

19. 既にある折り筋を使って折り筋をつける

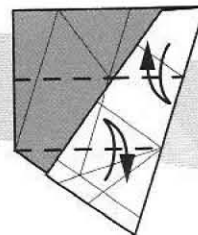

18. ○印を結ぶ線で
うしろに折る

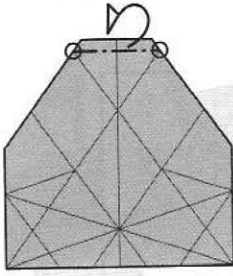

19. 左右を段折りしながら
箱型に立体化する

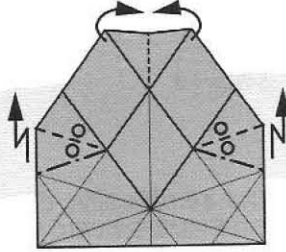

20. 途中図

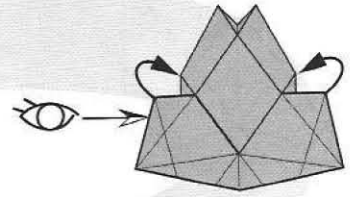

17. 既にある折り筋で
うしろに折る

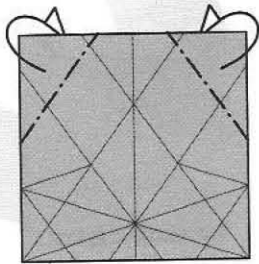

21. うしろの紙を巻き込む
ように折る
反対側も同じ

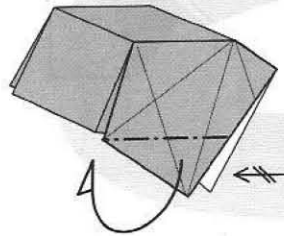

22.

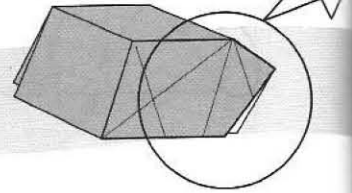

22. 半分の角度で
折り筋を付ける

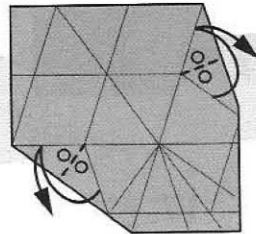

21. カドを反対側に折る

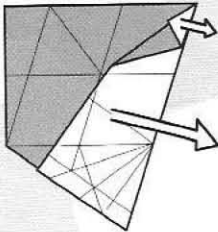

23. 両側面を少し立てて
立体化しながら段折りする

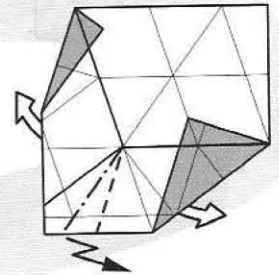

20. 縁を合わせるよう
に折る

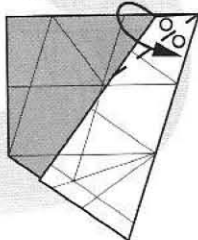

24. 既にある折り筋で
カドを内側に折る

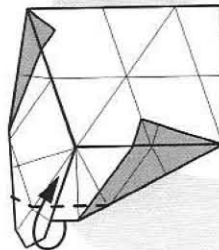

25. 既にある折り筋で
カドを内側に折る

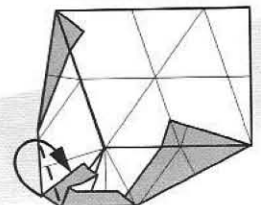

24. 中割折りでカドを内側に折る

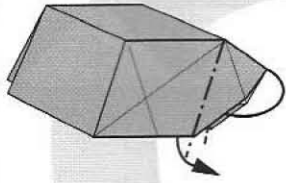

25. 同じものを二つ用意する

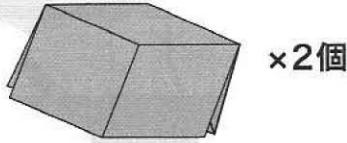

23. 半分の角度でカドをうしろに折る 反対側も同じ

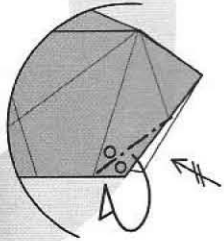

26. 互い違いに差し込んでまとめる

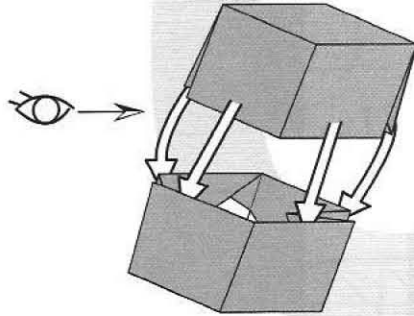

28. 完成

Type : acute-72

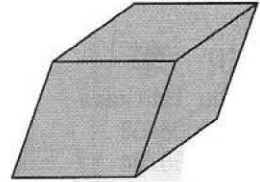

27. 途中図

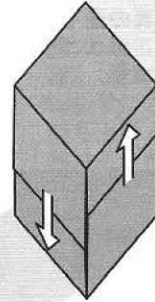

27. 谷折りした時につられて来るうしろの紙を平らにつぶす

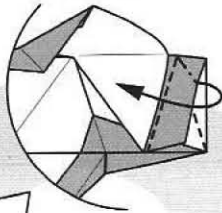

32. 完成

Type : obtuse-72

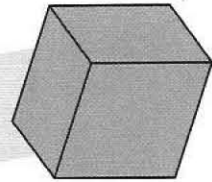

26. 段折りしながら全体を箱形に立体化する

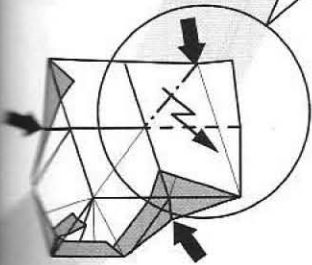

31. 途中図

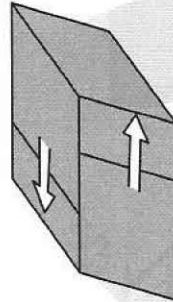

30. 互い違いに差し込んでまとめる

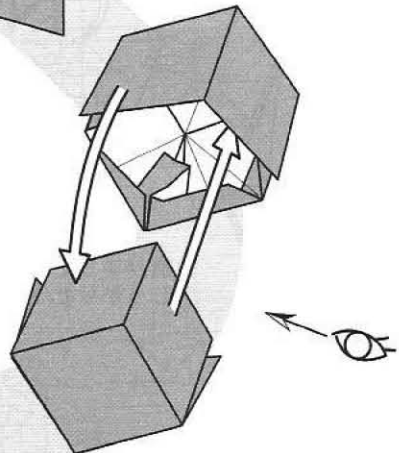

29. 同じものを二つ用意する

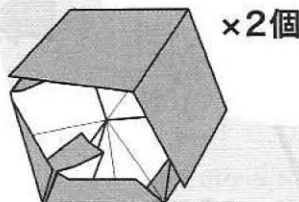

花のトートバッグ - Tote bag of flower -

市川 学

Manabu Ichikawa

創作 2008/03

作図 2008/04

写真の作品は15cmの紙を47枚使用していますが、写真の通りに組む必要はありません。このユニットで色々な組み方が出来ます。

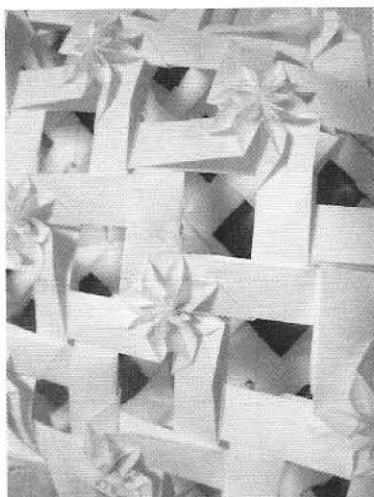
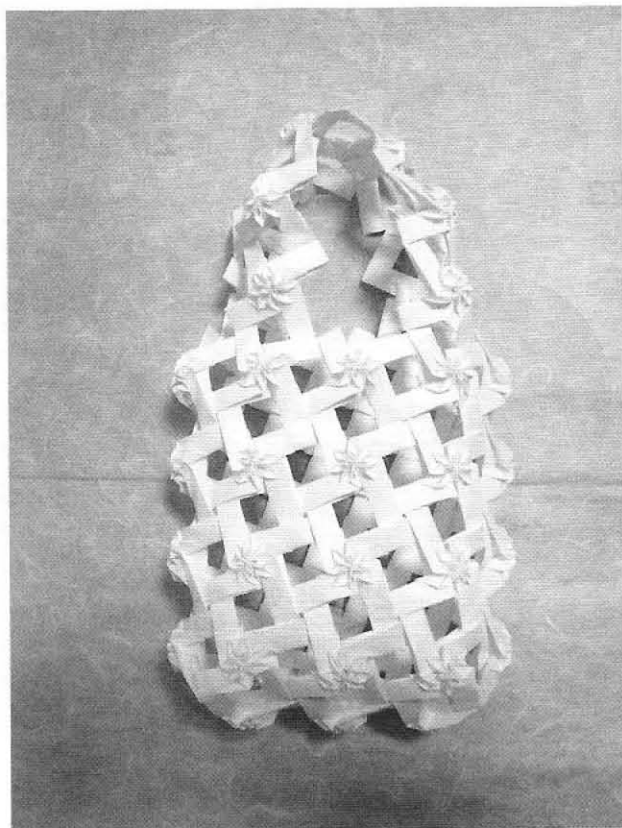

※ 鶴の基本形より

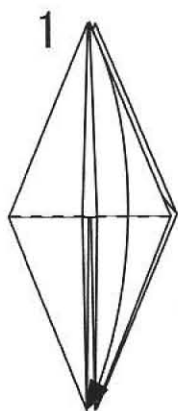

折り下げる
反対側も同様

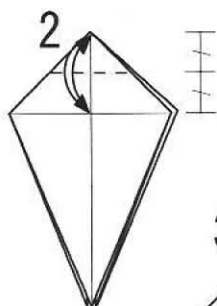

折りすじを
しっかりとつける

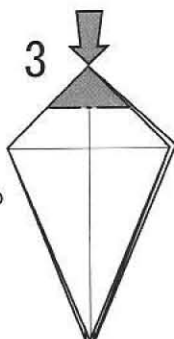

沈め折り (Open sink)

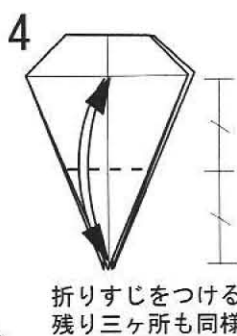

折りすじをつける
残り三ヶ所も同様

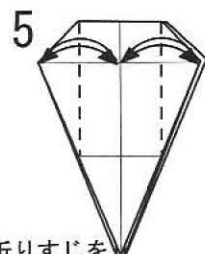

折りすじを
しっかりとつける
反対側も同様

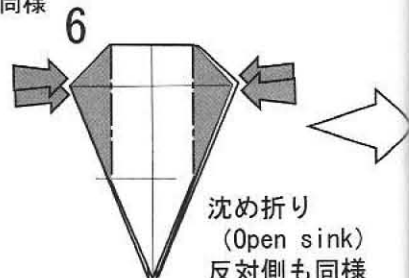

沈め折り
(Open sink)
反対側も同様

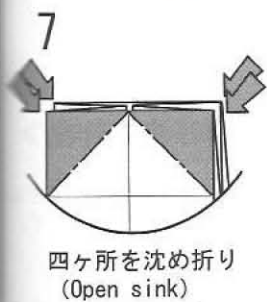

7
四ヶ所を沈め折り
(Open sink)



8
四ヶ所を沈め折り
(Open sink)

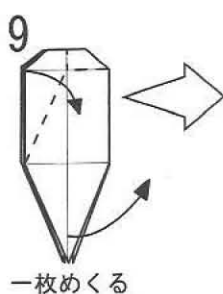

9
一枚めくる

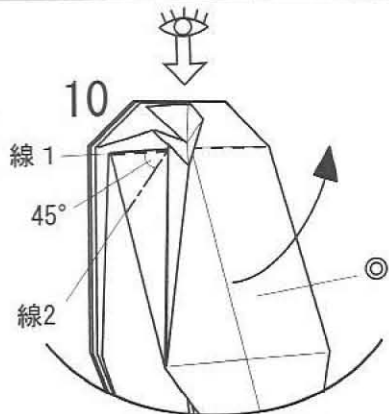

10
線1の山折りを谷折り、
線2 (線1から45度) を
山折りにし、◎を90度まで
持ち上げる
残り三ヶ所も 9, 10と同様

※ 7, 8の折りを省くと花の無い平らなユニットが出来ます。
冒頭の写真は全て花のあるユニットで組んでいます、
底になる面は平らなユニットの方が良いかもしれません。

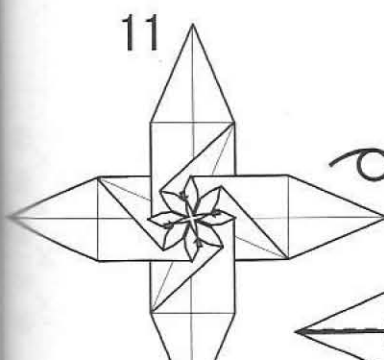

11
中央の花弁四枚、
外側の花弁八枚を
置き花の形を整える

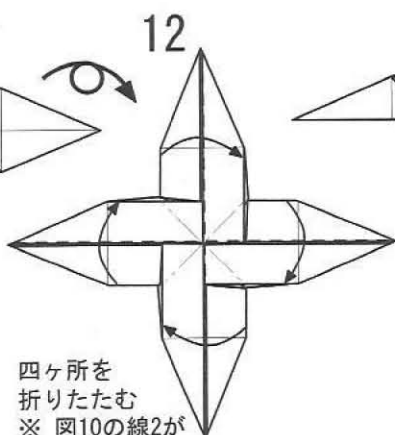

12
四ヶ所を
折りたたむ
※ 図10の線2が
山折り、線1が平らになる
(11→12で裏返しているため
10とは山、谷が逆)

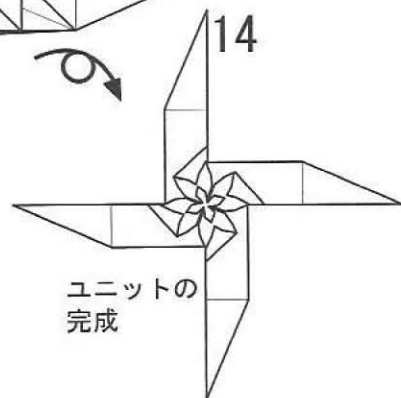
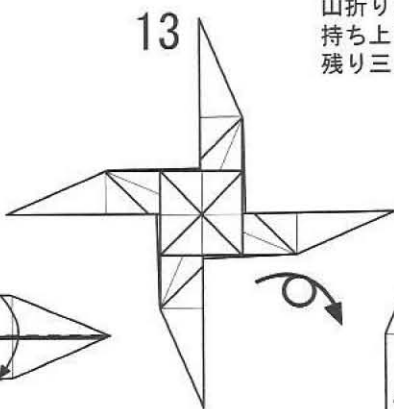

14
ユニットの
完成

組み方

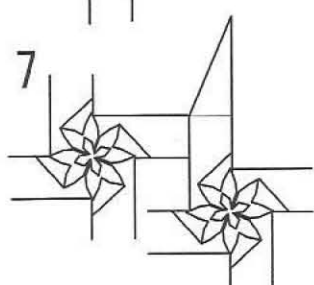
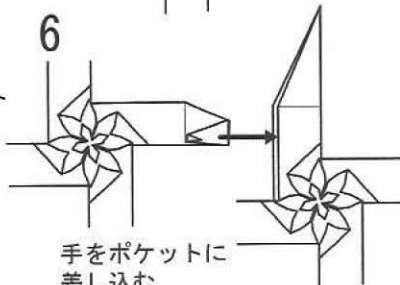
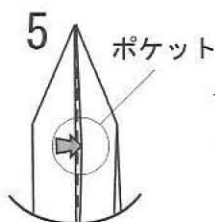
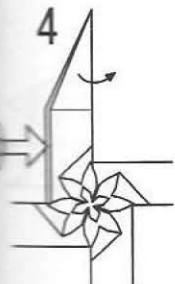
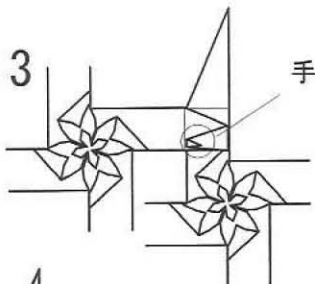
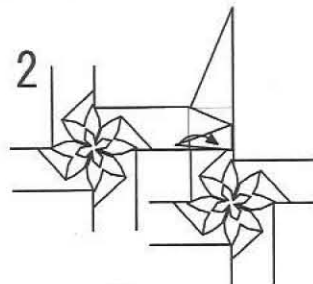
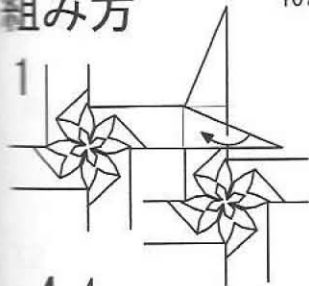

裏側から見る

手をポケットに
差し込む

四枚組み (④)

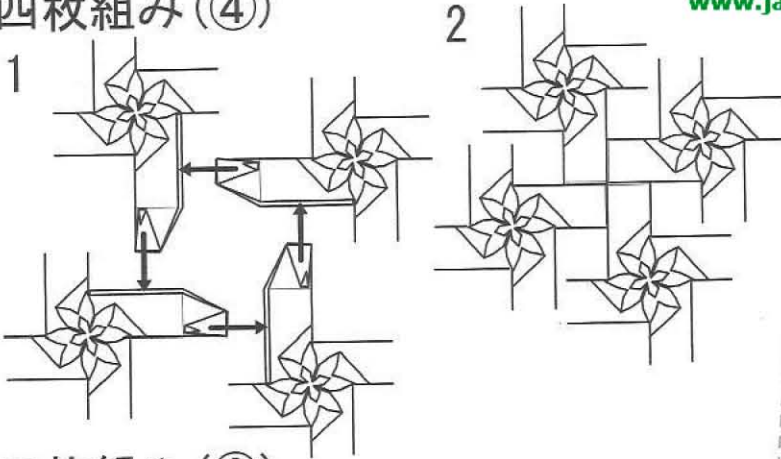

《冒頭の写真の作品》
組み方の一例です。
この通りに組む必要はありません。
×が一つのユニットになります。

三枚組み (③)

※ 冒頭の写真では
角に使用

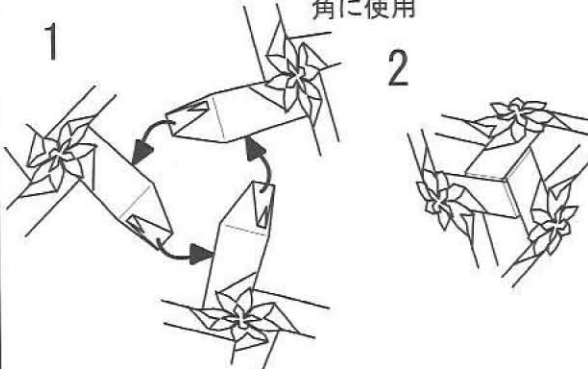

二枚組み (②)

※ 冒頭の写真では持ち手に使用

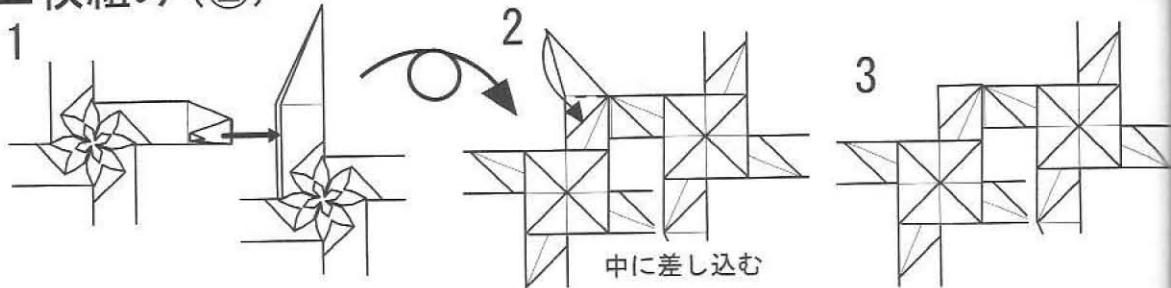

特殊三枚組み (③')

※ 冒頭の写真では入れ口-持ち手間に使用

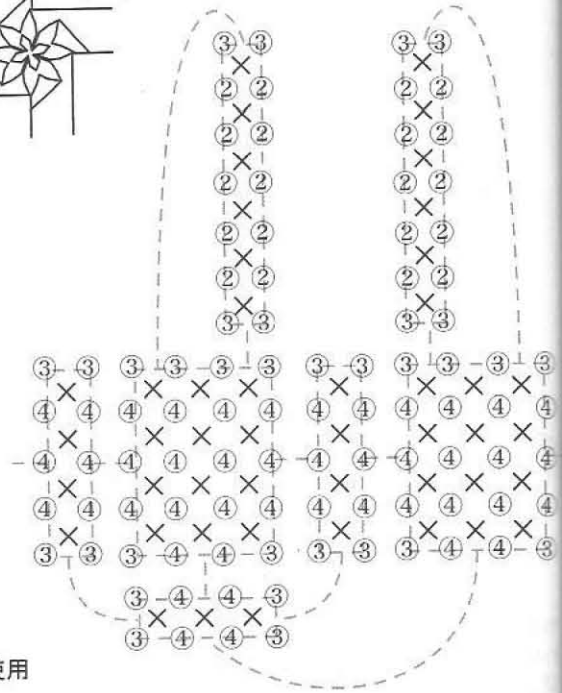
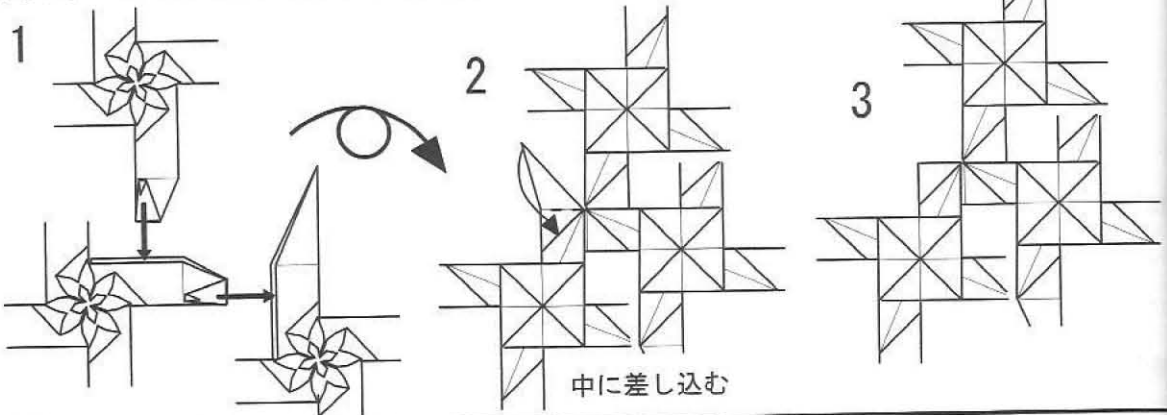

六角からの・花重ね

布施知子 / Tomoko Fuse

18cm角から切り出した六角形で練習

1~7は仕込み折り：後で役立つ折り

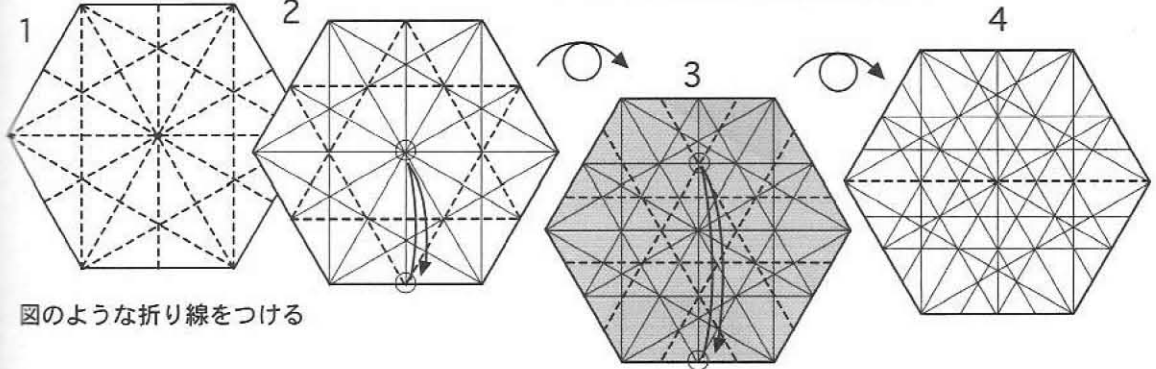

図のような折り線をつける

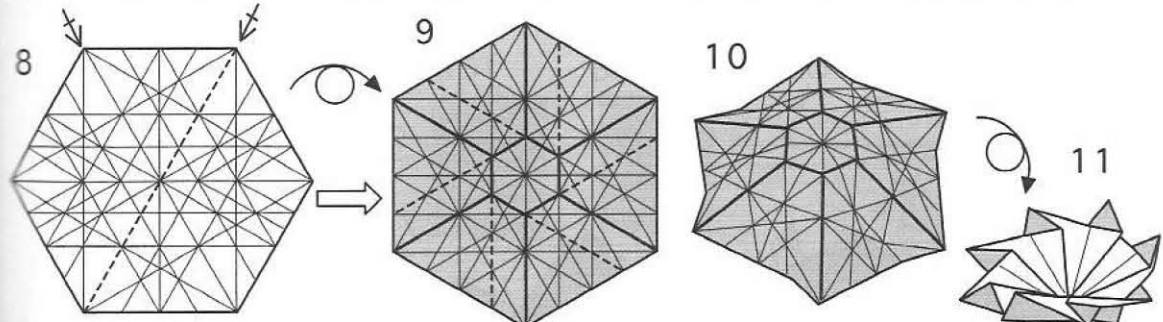
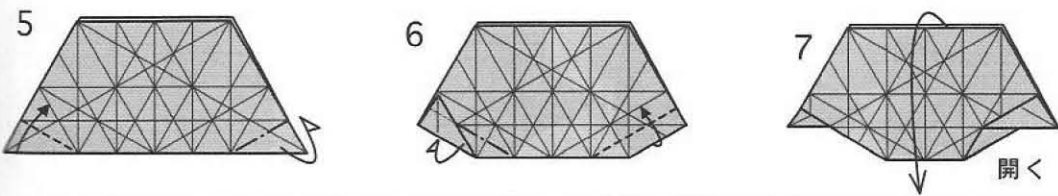

あと2か所も6~8と同じように折り線をつける

太線を山にしてつまみ、中央の六角形をテーブルのように平らにする

裏返してひだをねじって畳み、全体を平らにする

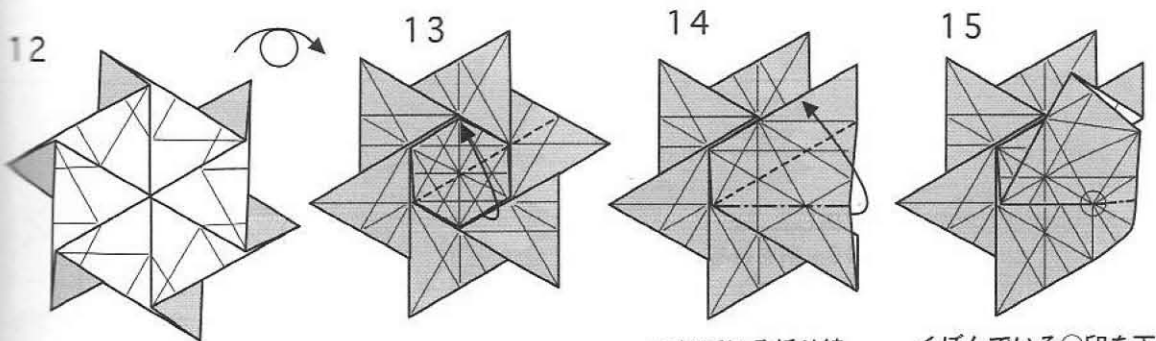

ついている折り線で開く

くぼんでいる○印を下から押して凸にする

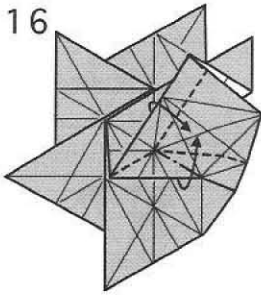

ついている折り線で2つのひだを寄せてたたむ

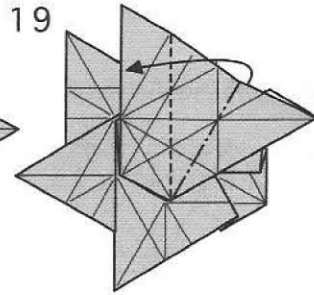
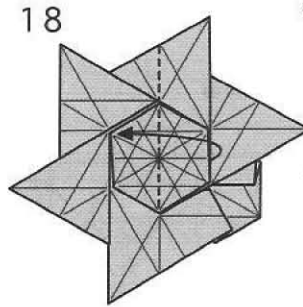
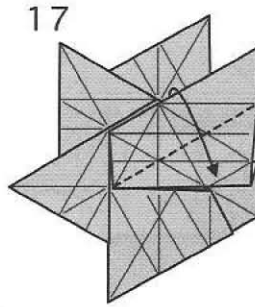

ついている折り線で開く

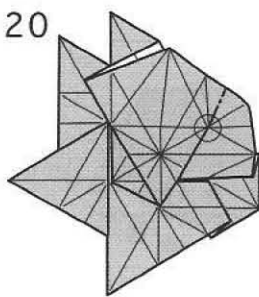

くぼんでいる○印を下から押して凸にする

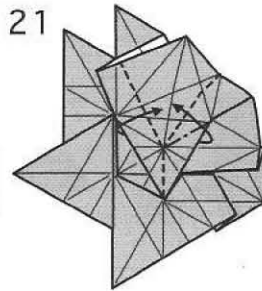

ついている折り線で2つのひだを寄せてたたむ

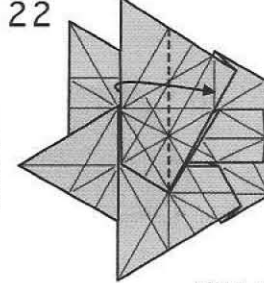

以下同じように合計6カ所を折る

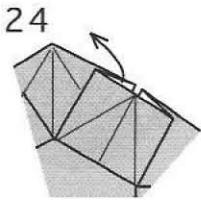
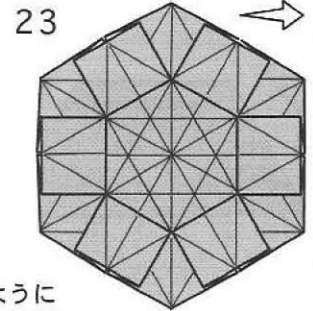

ひだを軽く開く

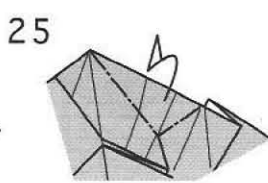

ついている折り線で折る

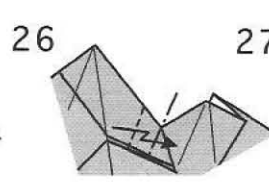

折ったら元にもどす

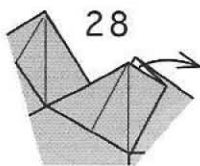
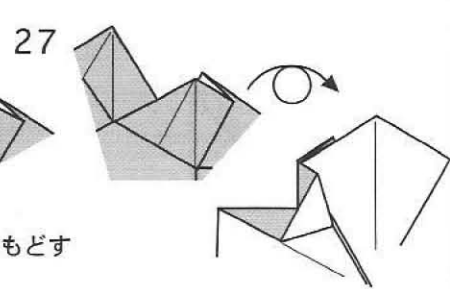

ひだを軽く開く

以下同じように合計6カ所を折る

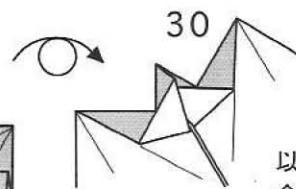
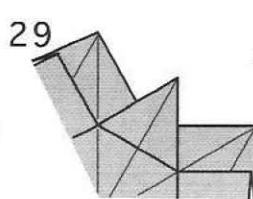

以下同じように合計6カ所を折る

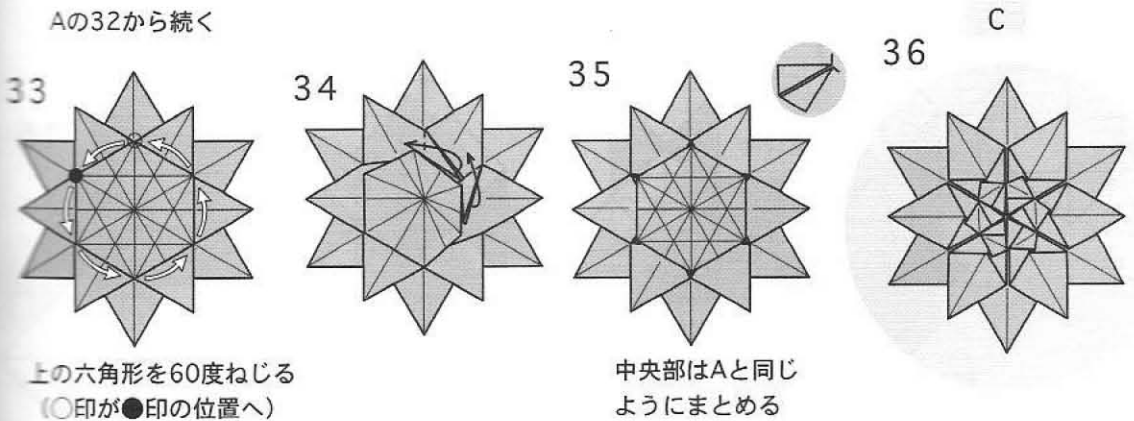
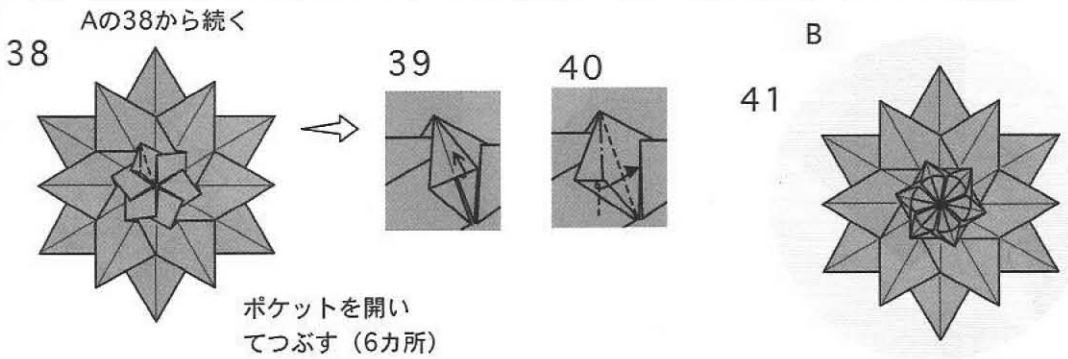
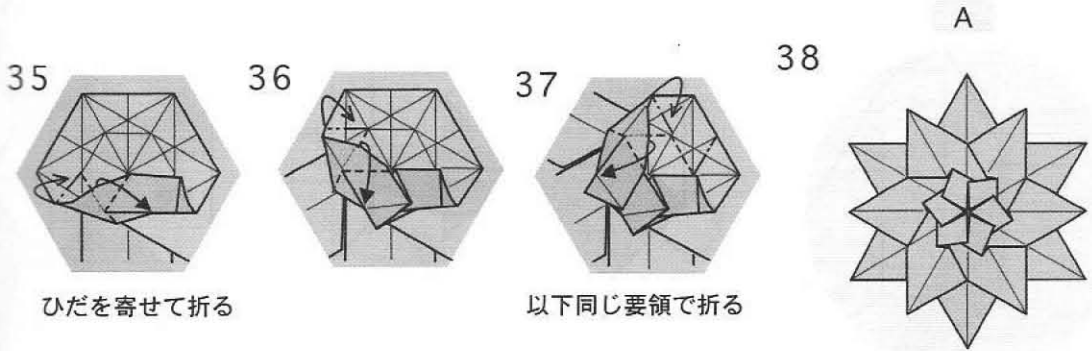
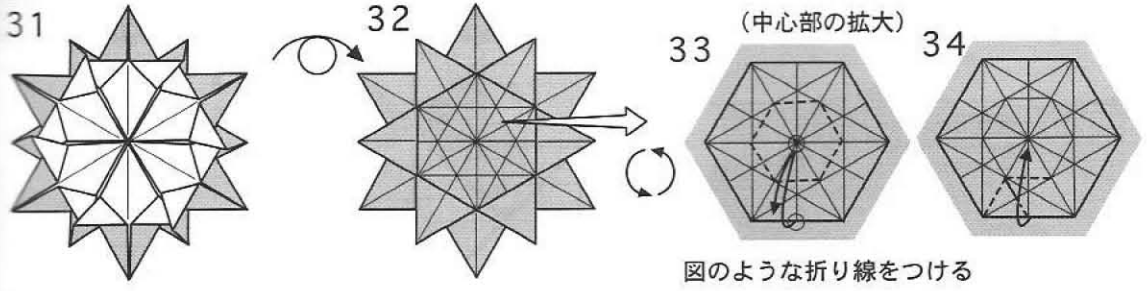

F-22A Raptor

創作 / 青木 良

試作 / 2003.1

作図 / 2008.6.30

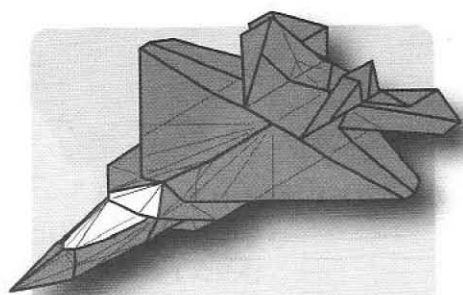

1

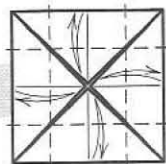

ざぶとん
基本形から
はじめます

2

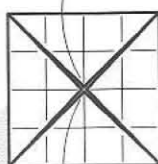

3

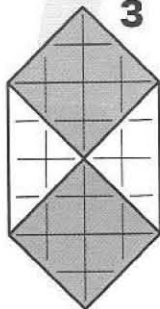

4

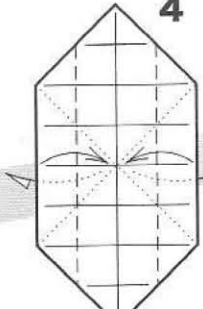

5

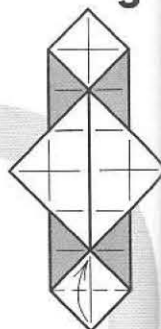

後ろの
三角を出しながら
折ります

9

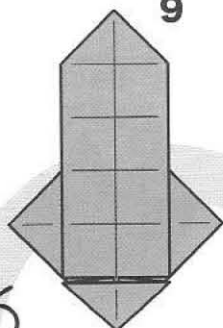

8

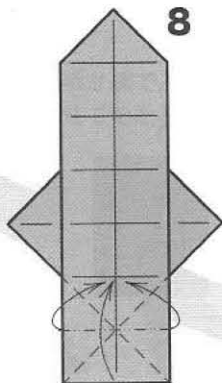

7

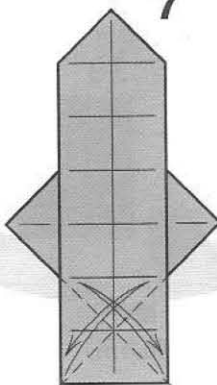

6

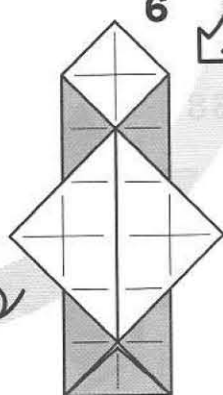

10

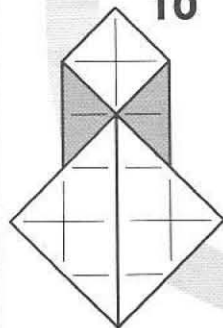

よせるように
折りたたみます

11

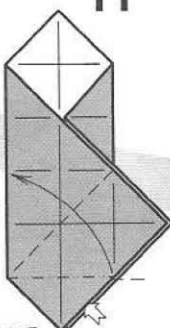

12

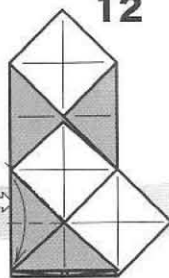

開いて
折りたたみます

13

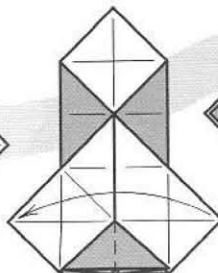

14

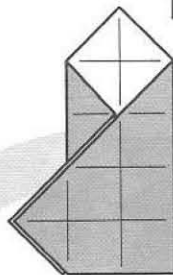

反対側も
11~13と
同じ

15

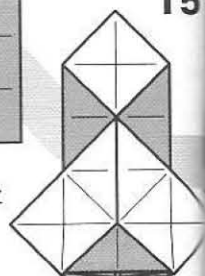

開いて
折りたたみます

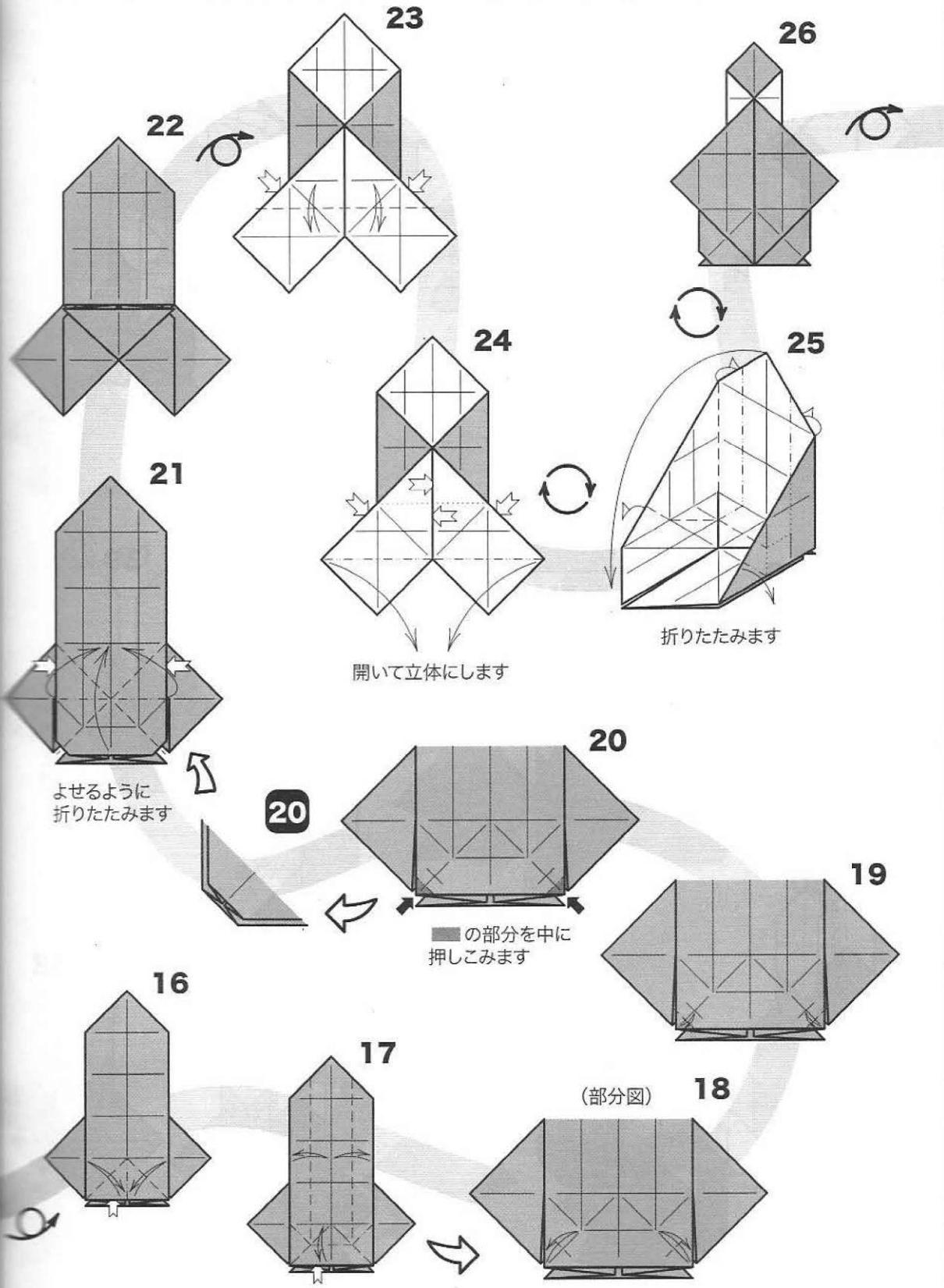

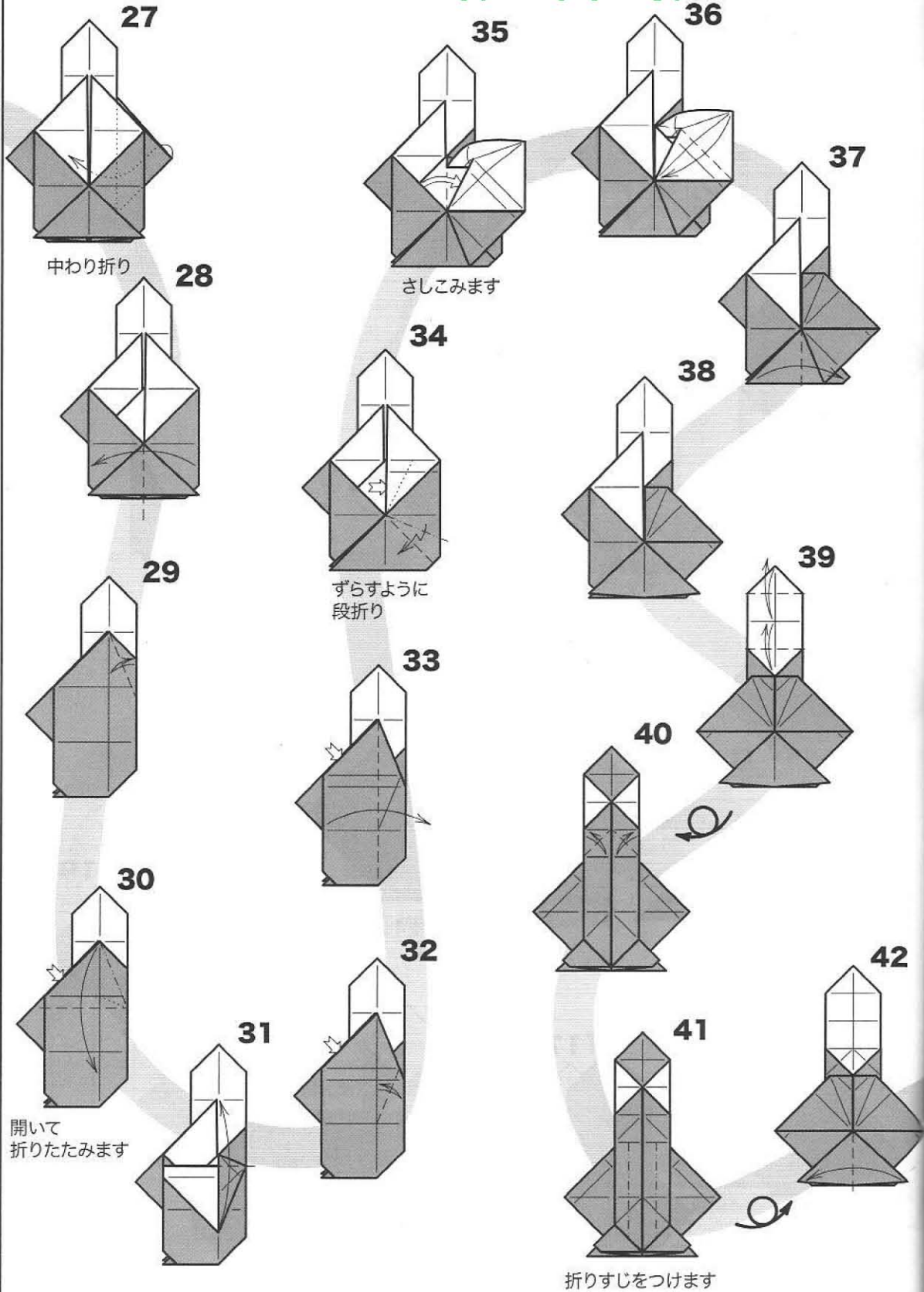

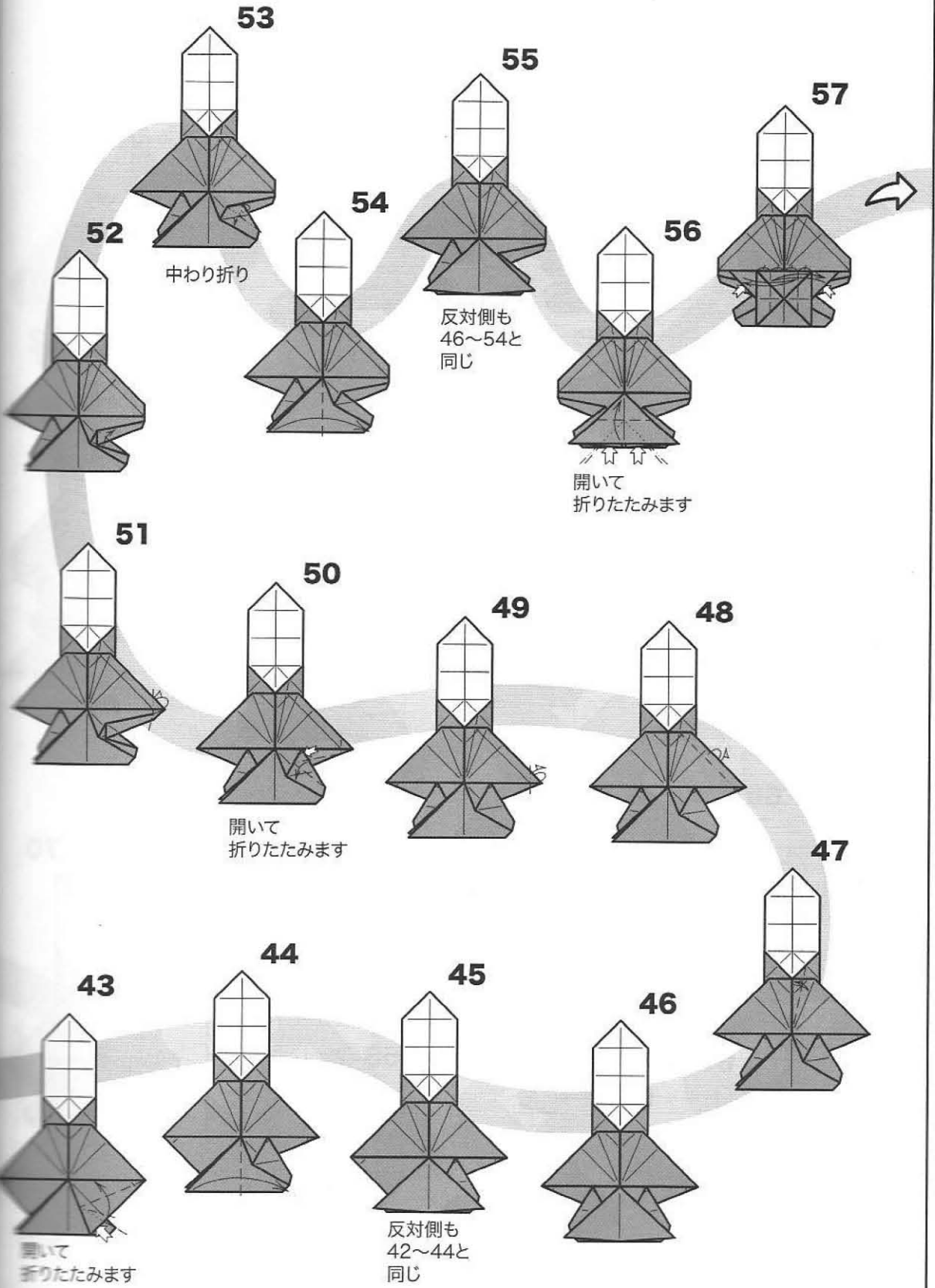

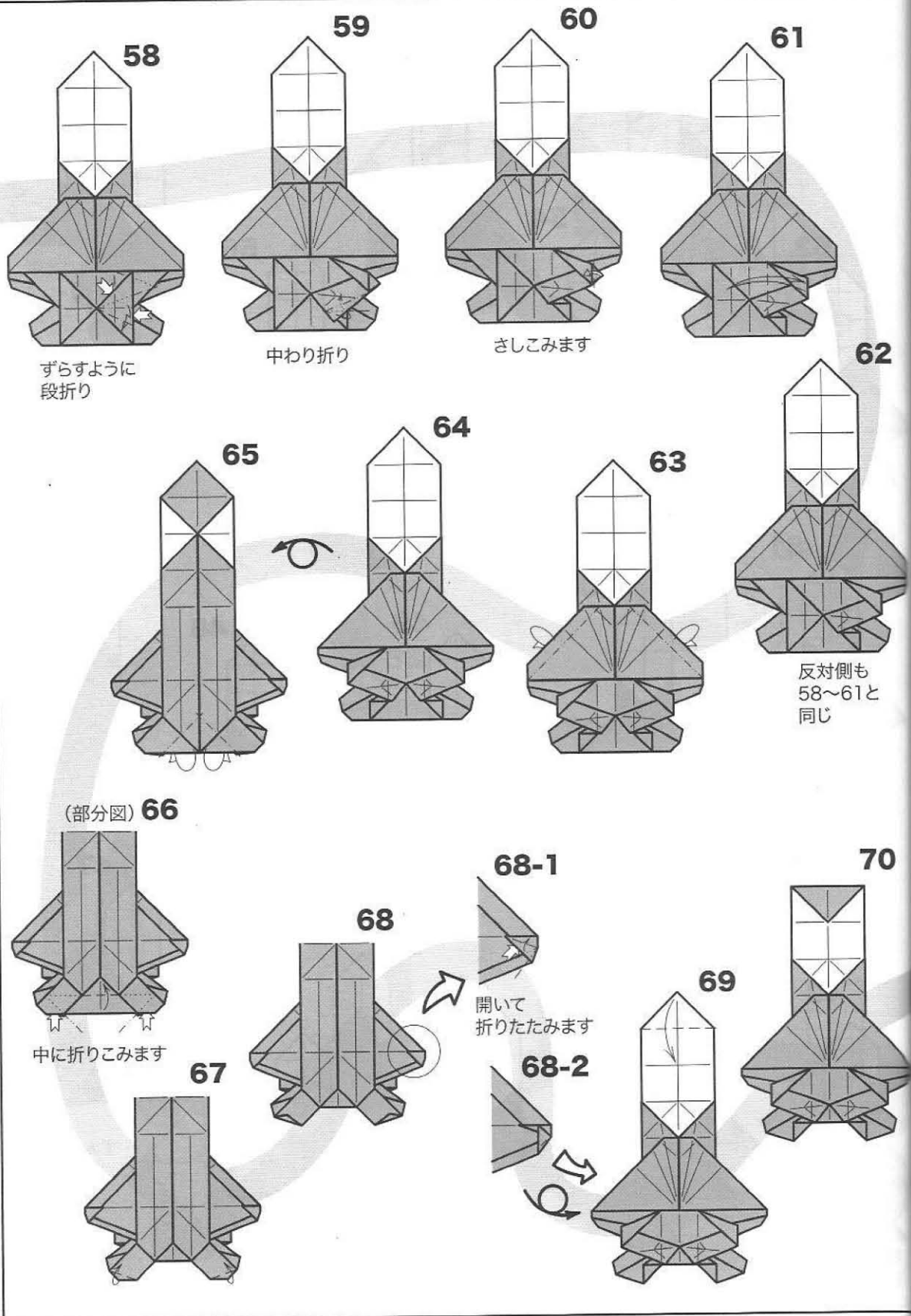

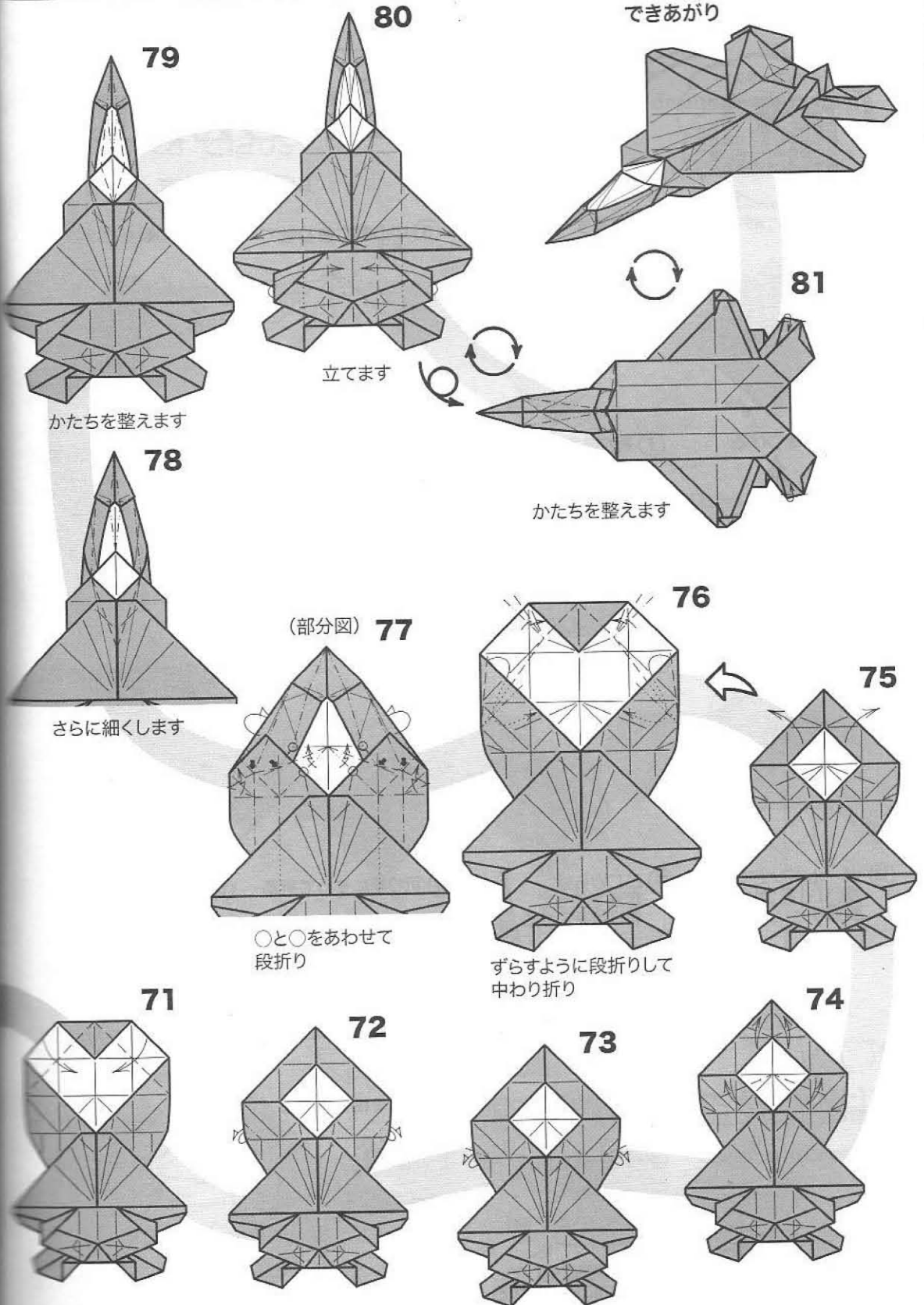

79

かたちを整えます

80

立てます

できあがり

81

かたちを整えます

78

さらに細くします

(部分図) 77

○と○をあわせて
段折り

76

ずらすように段折りして
中わり折り

75

71

72

73

74

おりがみひこうき

フェニックス PHOENIX

山下 明 創作 : 2007年9月
作図 : 2008年6月

<フェニックス>
エジプト神話の鳳鳥でアラビア砂漠に生息。五百年に一度自ら火中に入って焼かれその灰の中から若い姿で再生するといわれる。不死鳥。

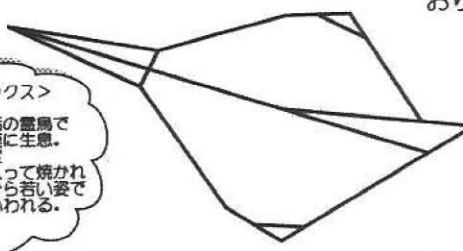

- ① 折り筋をつける。
- ② 裏返す
- ③ 中心線に合わせて折る
- ④ 折り筋をつける
- ⑤ ※ 図を拡大します
- ⑥ 折り筋をつける
- ⑦ 折り筋をつける
- ⑧ 折り筋をつける
- ⑨ ④でつけた折り筋で向こう側へ折る
- ⑩ 折り筋をつける
- ⑪ 裏返す
- ⑫ ⑧でつけた折筋で折り上げる

- ⑬ 裏返す
- ⑭ 折り筋にそって折る
- ⑮ ここからは定規を使って折り筋をつける
- ⑯ ボールペンで交点に強い「J」をつけ裏返す
- ⑰ 「J」から折り筋をつけ翼端を少し、折り上げる
- ⑱ 要所を糊付けする

※ 図は90度回転しています

(※横から見た図)

(※後ろから見た図)

翼端は翼平面に対して、30度くらいに折り上げる

※説明のため、便宜的に⑩図を用いています。

糊付けはほんの少～し。程度の大きさを十分です!

この左右の裏側を ここは左右いずれか一箇所だけでよい

サンタクロース

Santa Claus

design & diagrams:
照井貞一郎
Teiichiro Terui
2007.12.25(Tue)

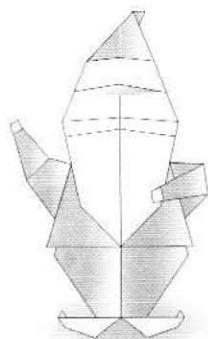

1.

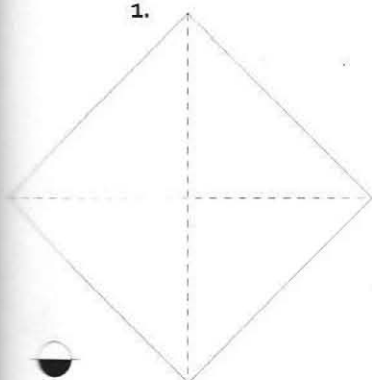

2.

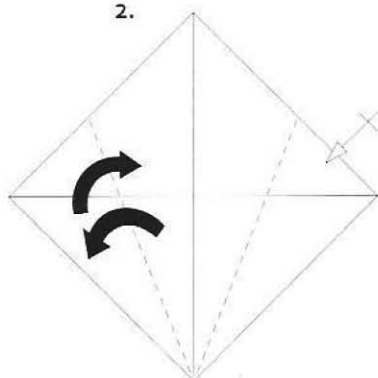

3.

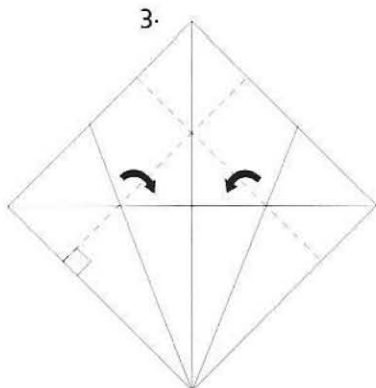

4.

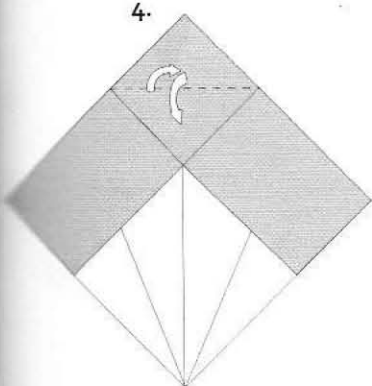

5.

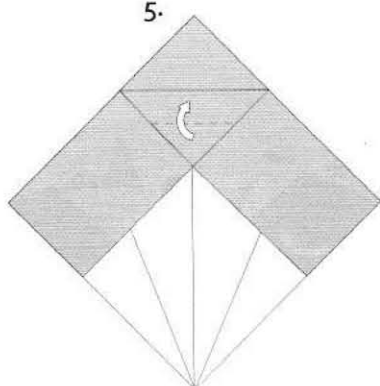

6.

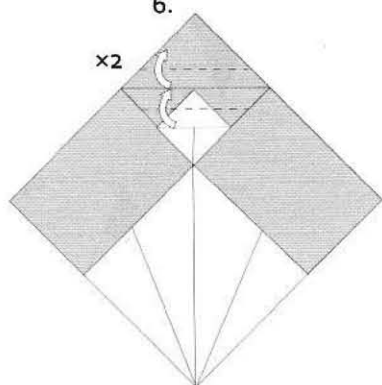

7.

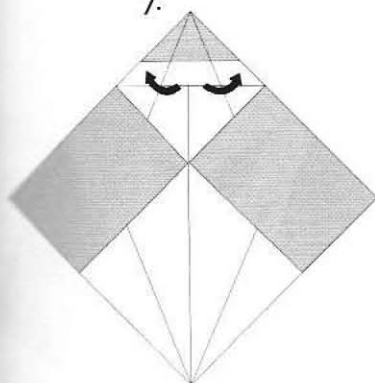

8.

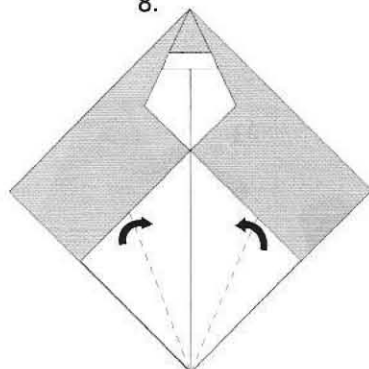

9.

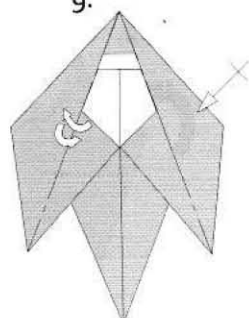

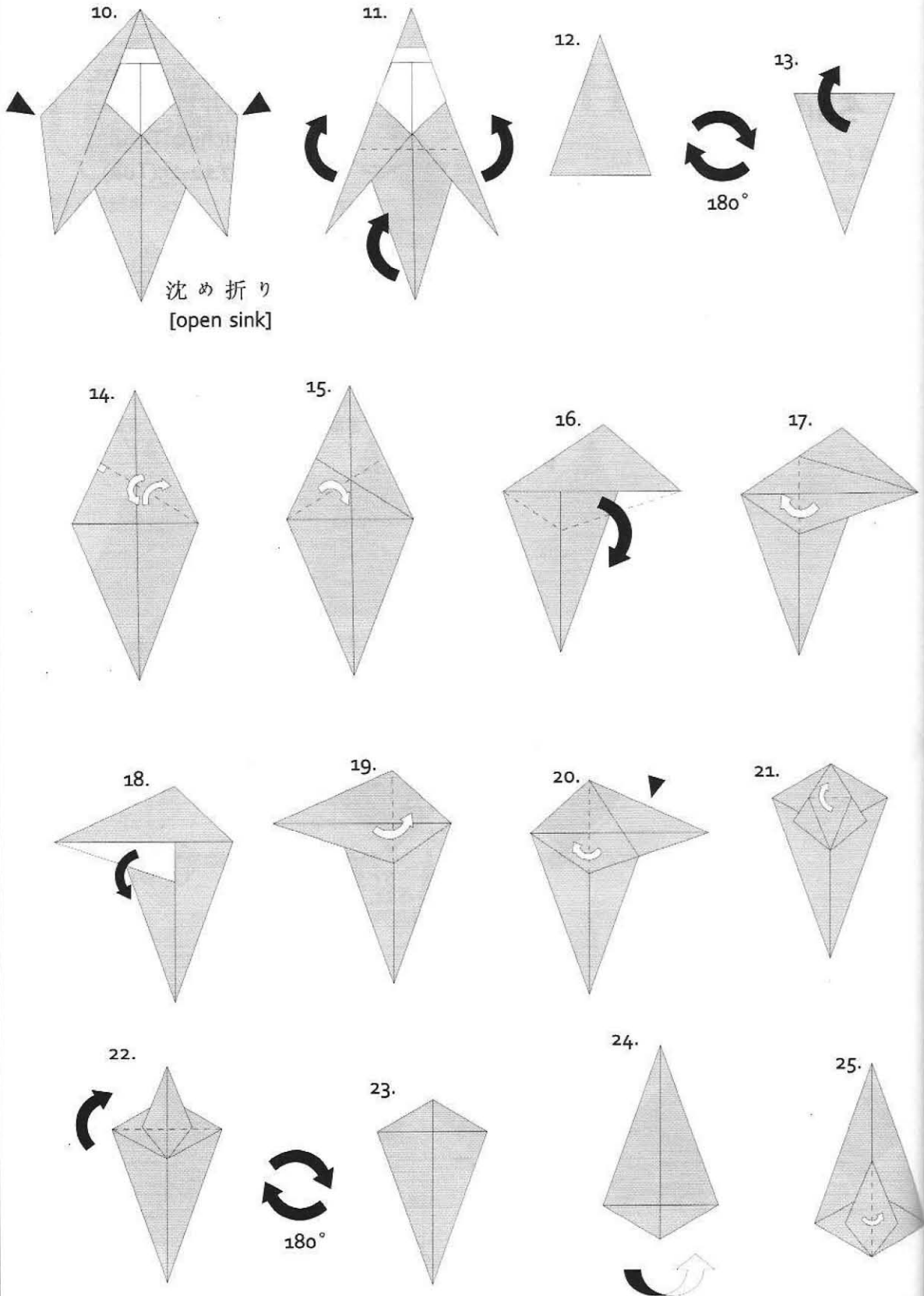

26.

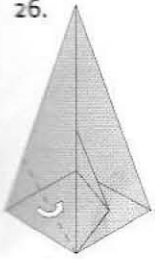

27.

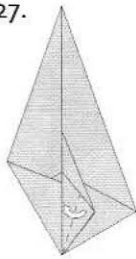

28.

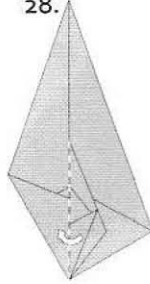

29.

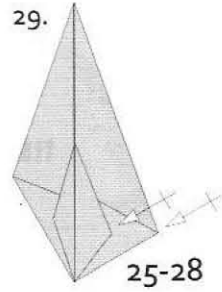

25-28

30.

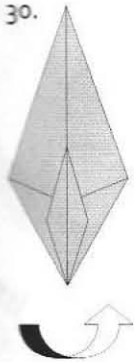

31.

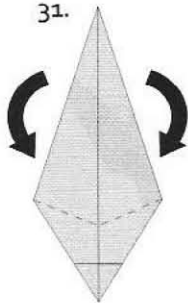

32.

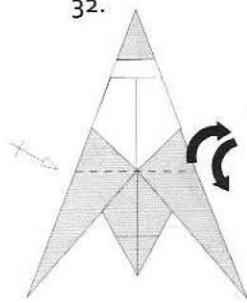

33.

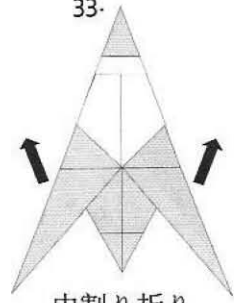

中割り折り

34.

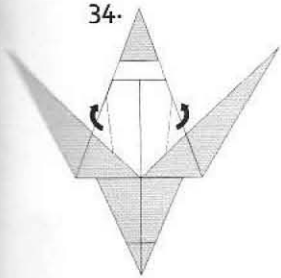

35.

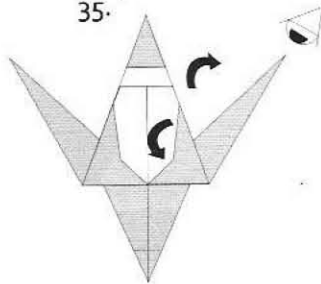

36.

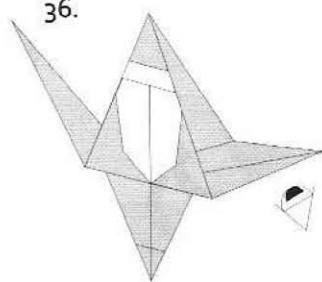

37.

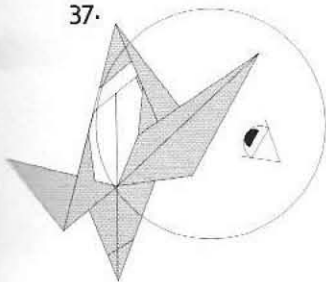

38.

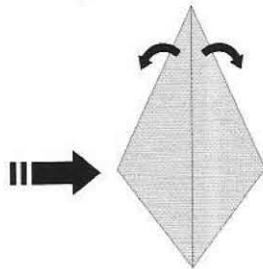

適度に少し開く

39.

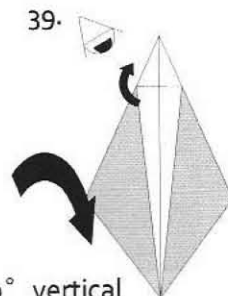

90° vertical

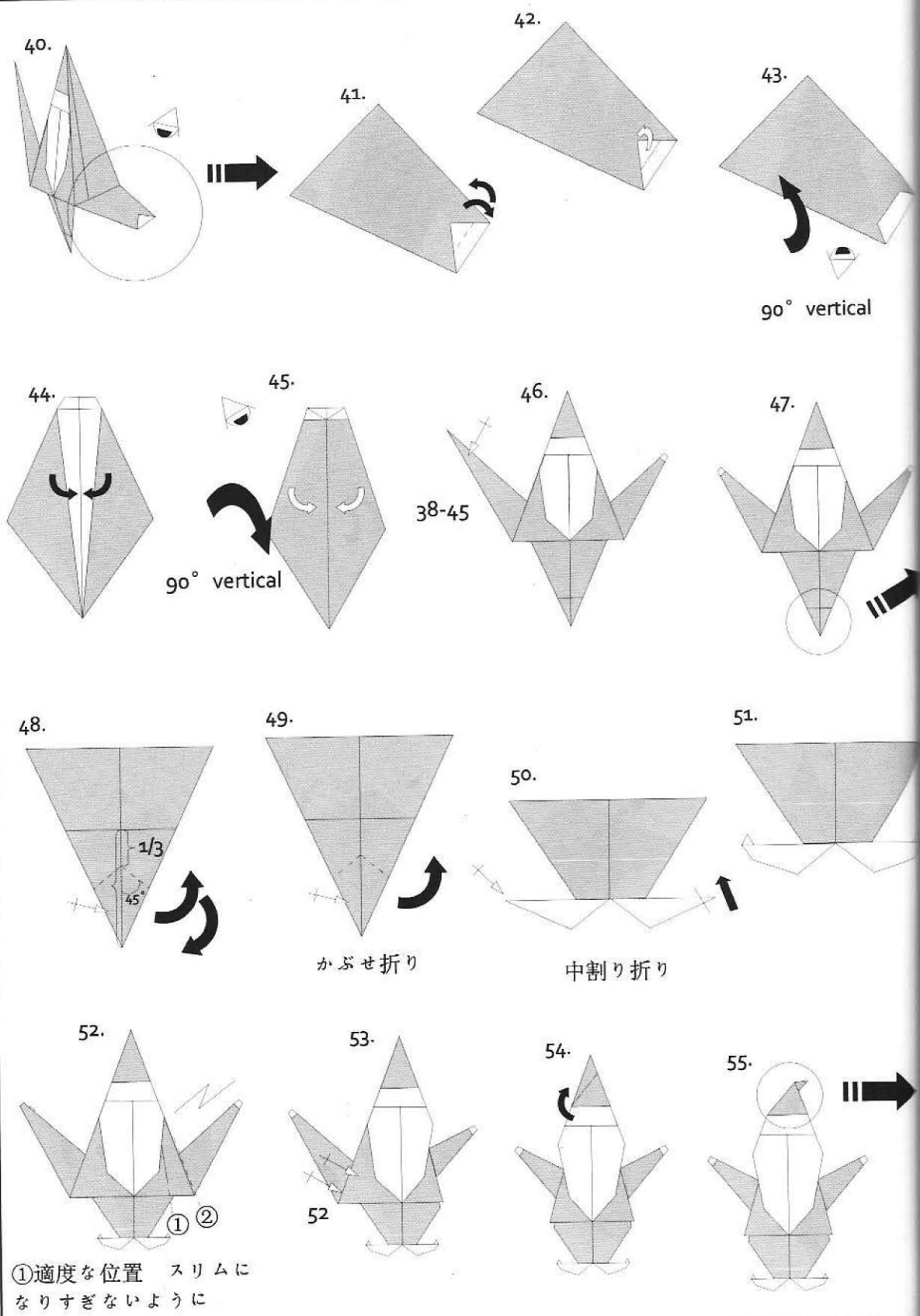

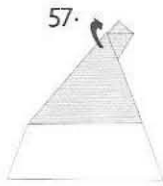

ピンセットなどで隙間に差し込む

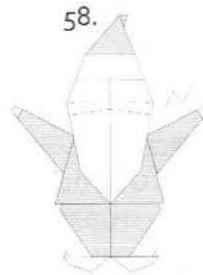

顔と髭の境界線

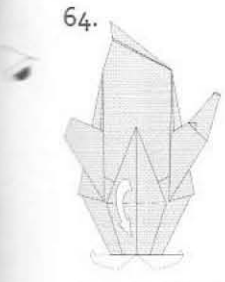
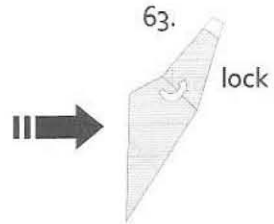
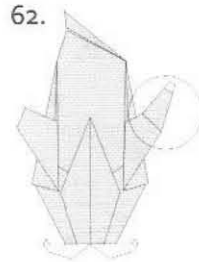
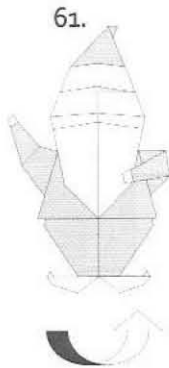
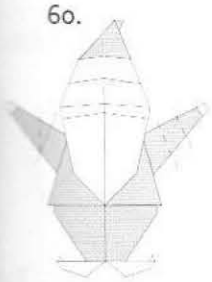
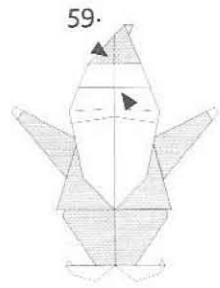

スタンドを使用する場合

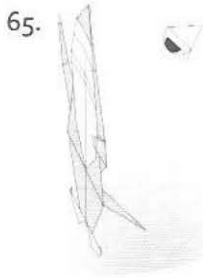

[side]

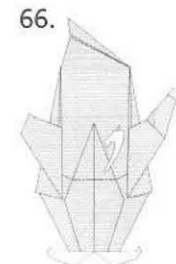

スタンドを使用しない場合

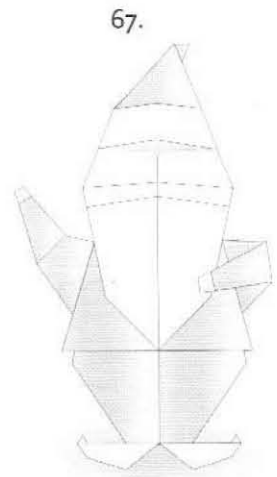

完成



(C) 2007 T1 老師

(C) 2007 T1 老師

アクセサリを持たせたり、手や腕に表情をつけた一例。

～金魚すくゑあ～

GoldFish Type Square 作／2007.6 霞誠志

この作品は第8回折紙探偵團関西コンベンションで田中将司さんと小松英夫さんが始めたハバ折りのアイデアを元にして制作したものです。むなびれの部分を目にしたり、尾の部分の沈め折りを省略することも可能です。その他にもいろいろ工夫してみてください。

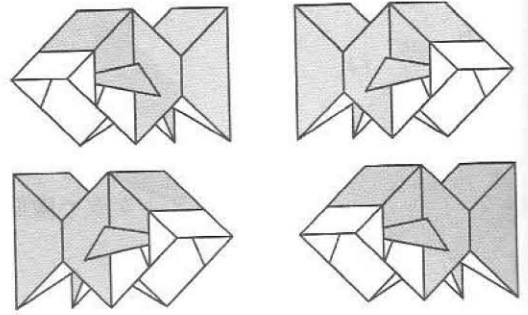

1. 折り筋を付ける

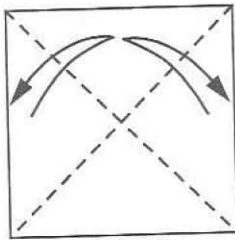

2. 折り筋を付ける

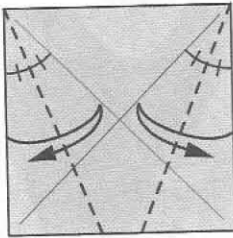

3. ○印を基点にして折り筋を付ける

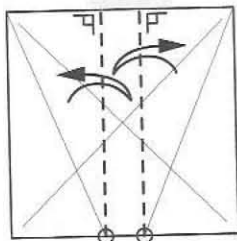

4. 縁を折り筋に合わせて折り筋を付ける

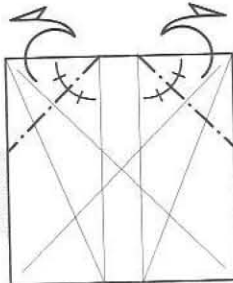

5. 折り筋を付ける

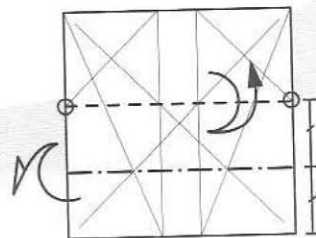

9. ●印を合わせて折り筋を付ける
反対側も「8～9」と同じようにして折り筋を付ける

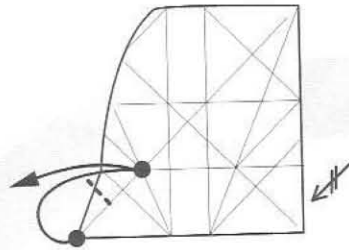

8. ○印の間だけを折る

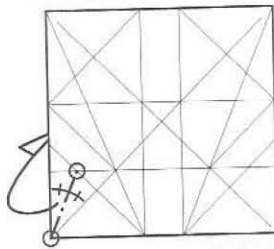

7. ○印の間に折り筋を付ける

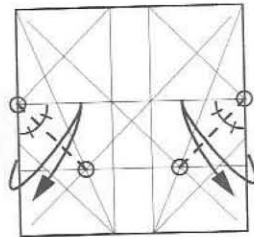

6. ●印を合わせて折り筋を付ける

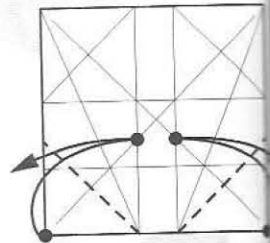

10. 図の位置にだけ折り筋を付ける

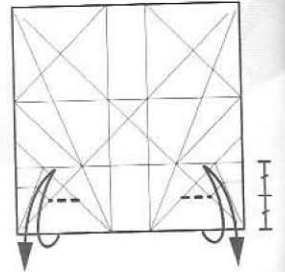

11. 図の位置にだけ折り筋を付ける

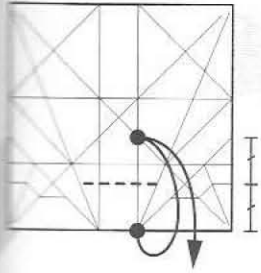

12. 既にある折り筋で折る

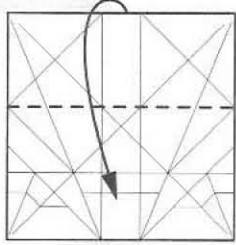

13. 既にある折り筋で折る

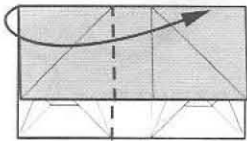

14. 線を合わせて折り筋を付ける

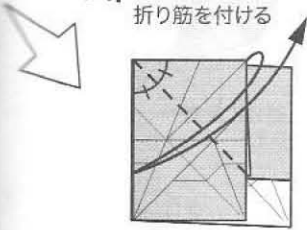

15. 「14」で付けた折り筋と縁が揃うように折る

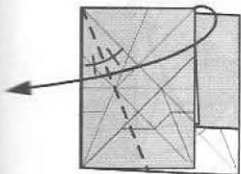

16.重なっている紙を引出して平らにするように折る

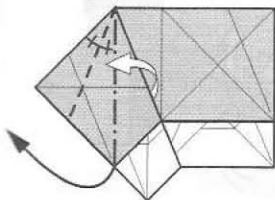

12. 既にある折り筋で折る

22. 点線の位置へ折り返す

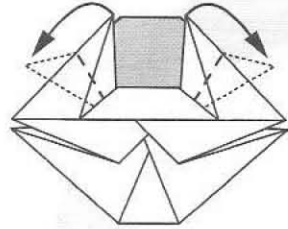

21. ○印を結ぶ線で折る

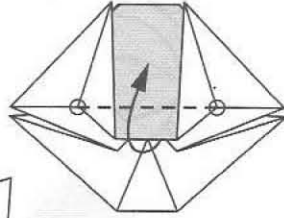

20. 反対側も「13～19」と同じように折る

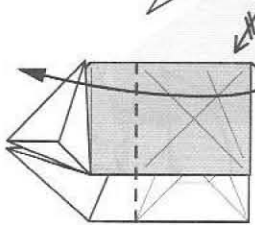

19. 中割折り

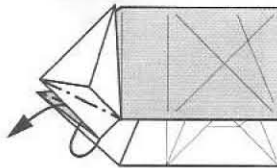

18. ●印を合わせてずらすように折る

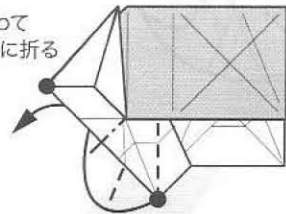

17. ●印を合わせて折る (つられて浮いてくる紙は平らにつぶす)

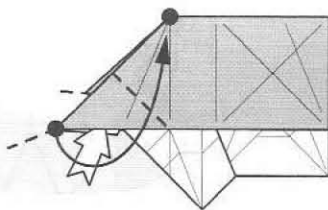

23. 上の層を少し持ち上げて
内側を見る

☆上の紙の層を
透視・・・

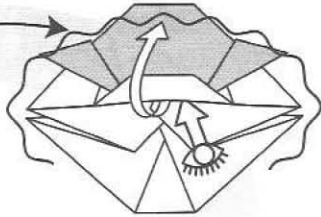

尾の部分の沈め折りを全部省略
すると俺みたいにクールな体型に
なれるぜ! ただし、上手く内側の
カドをまとめるよ。なっ!

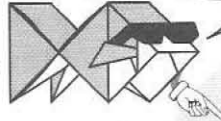

32. 完成

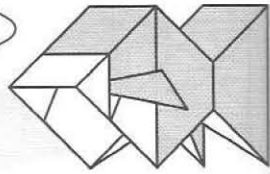

24. 沈め折り・・・
open sink

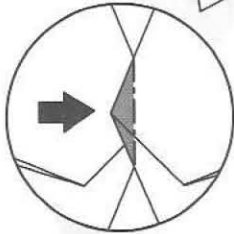

31. 尾の部分
立体的な沈め折り

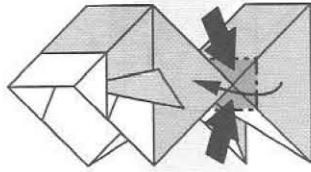

30. 尾になる部分を開いて
立体化する

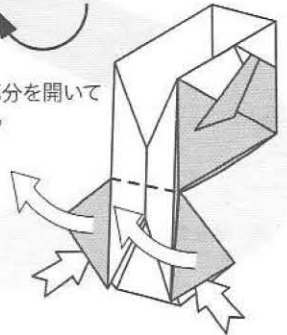

29. 沈め折りした部分に反対
側のカドを差込む

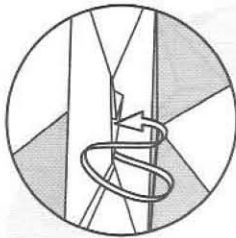

25. 沈め折りした部分に
反対側のカドを差込む

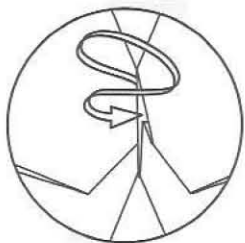

28. 沈め折り・・・
open sink

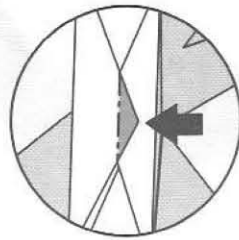

26. 中央のカドを
上にあげる

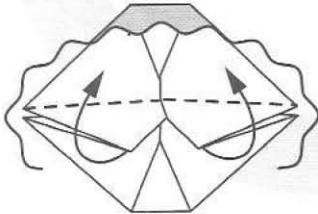

27. (左側が上になるように)
●印を合わせて互い違いに折る
体の部分は箱型になるように立体化する

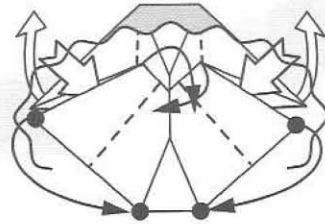

[特別付録=金魚すくいやあ~専用]

By Kasumi Seishi

[ポイ]

1. 折り筋を付ける

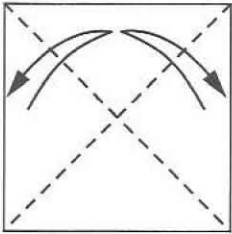

2. 縁を折り筋に合わせて折る (つられて浮いてくる紙は平らにつぶす) 反対側も同じ

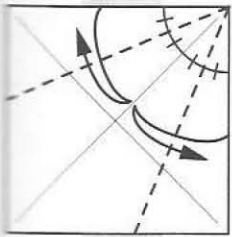

3. ○印を基点に折る

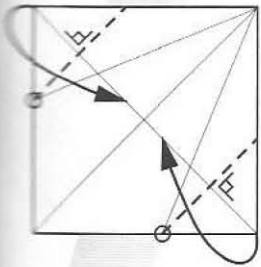

4. 印をつける

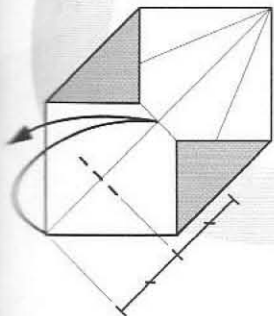

5. (既にある折り筋で)縁を折り筋に合わせて折る 反対側も同じ

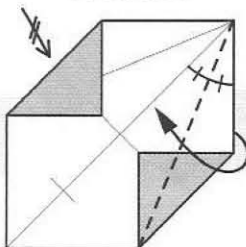

6. カドを○印に合わせて折る

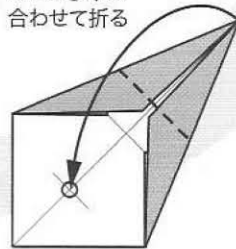

7. 1/4の位置で折る 反対側も同じ

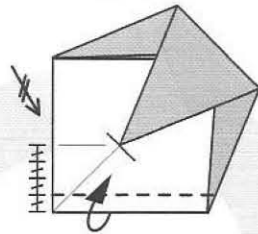

8. ○印の位置で折る

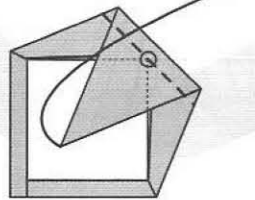

10. それぞれのカドを後ろに折って形を整える

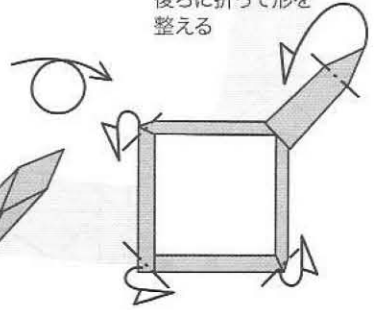

11. 「完成」

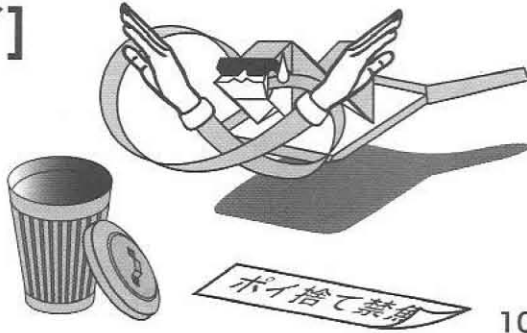
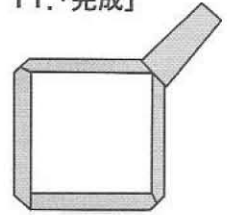

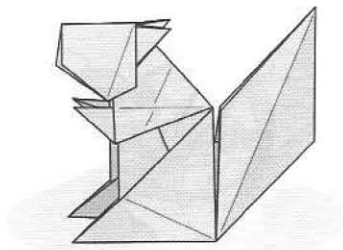

角度制限あり

Square

Squirrel

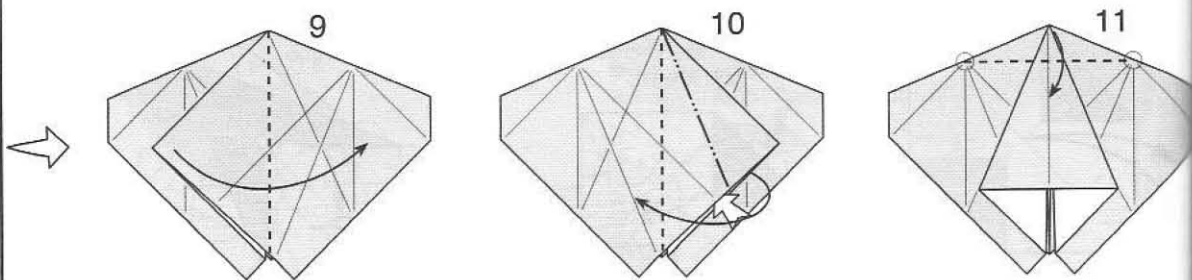
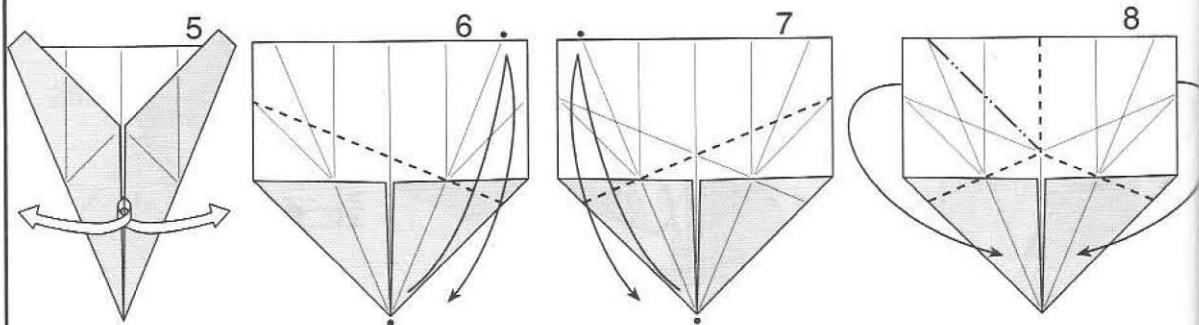
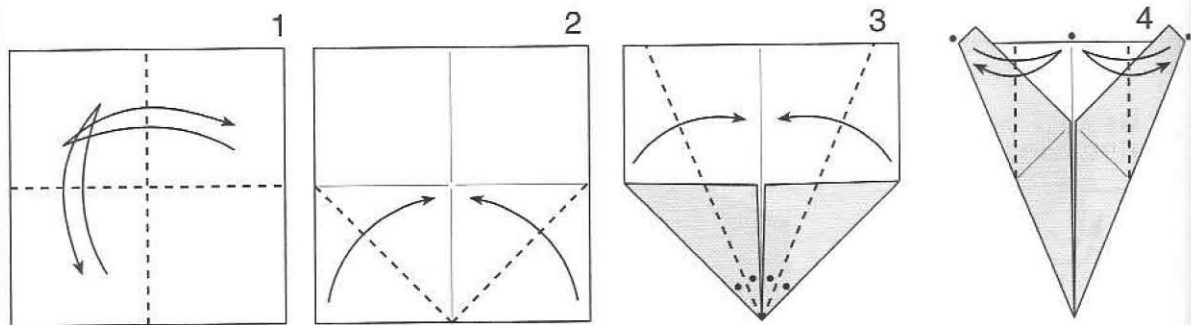

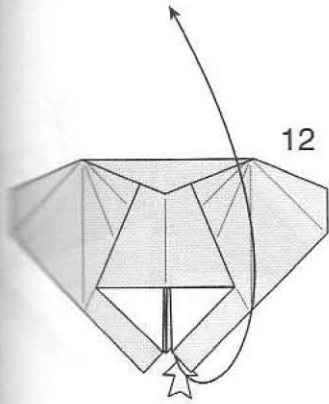

12

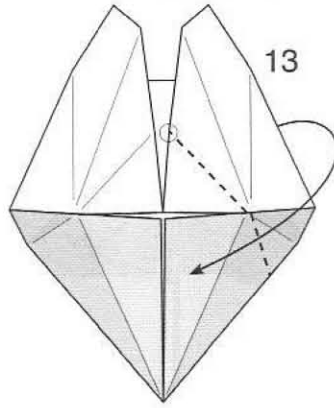

13

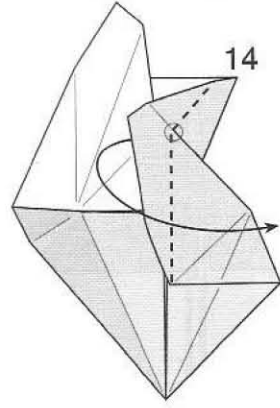

14

13-14と同じ

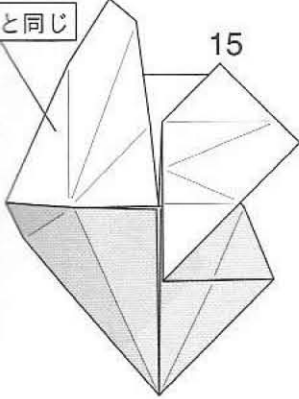

15

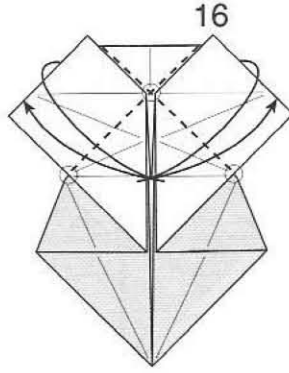

16

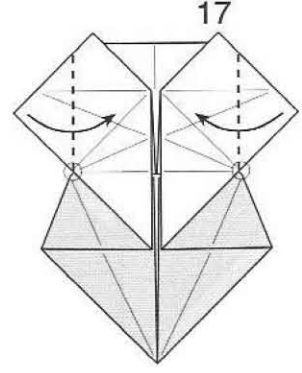

17

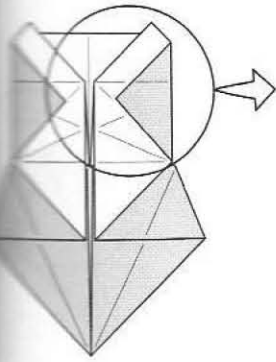

18

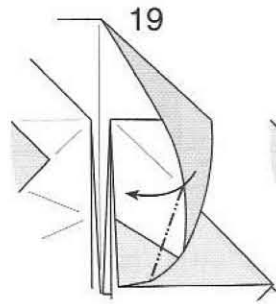
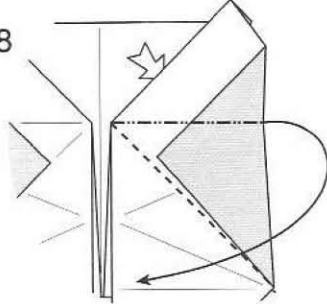

19

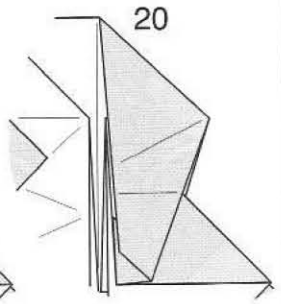

20

18-20と同じ

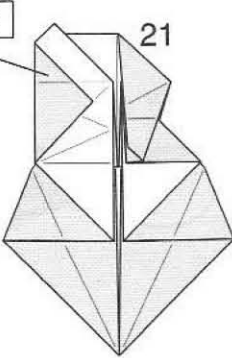

21

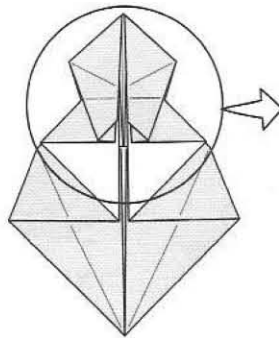

22

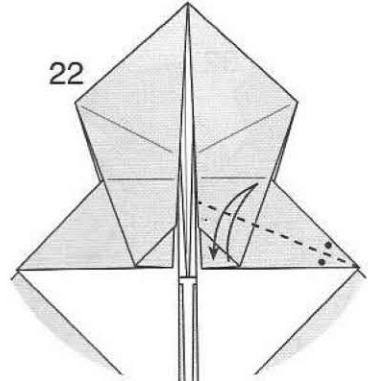

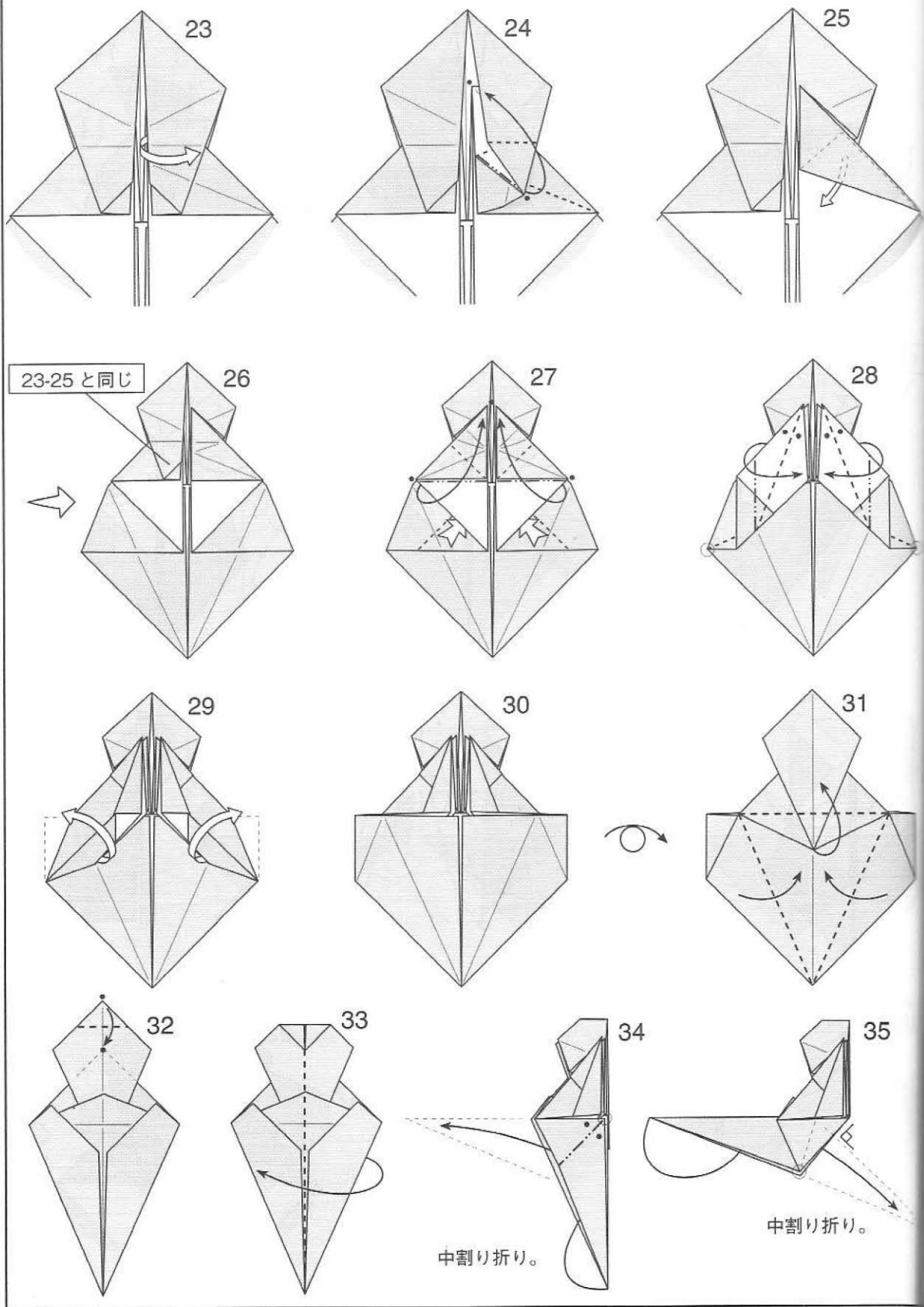

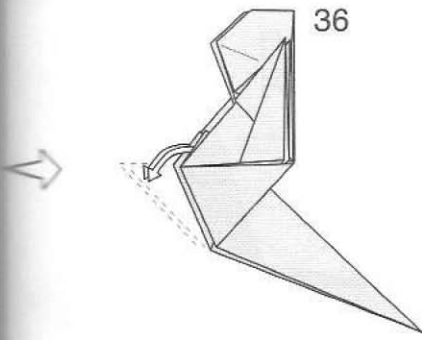

36

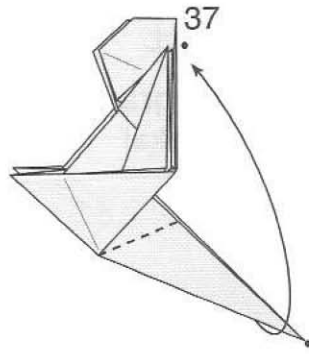

37

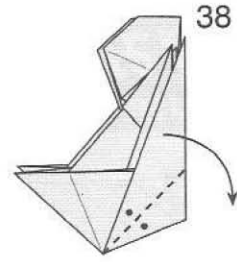

38

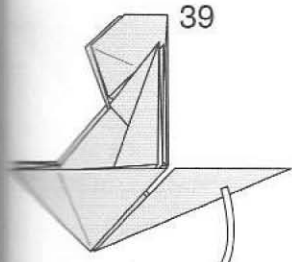

39

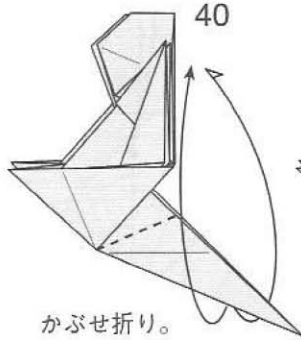

40

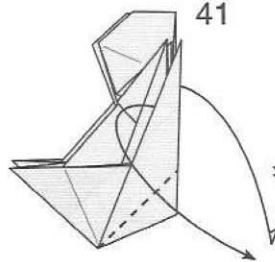

41

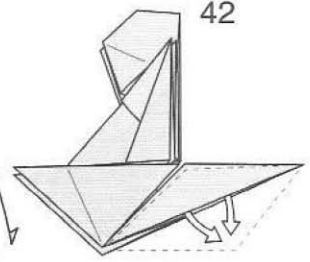

42

36まで戻します。

かぶせ折り。

かぶせ折り。

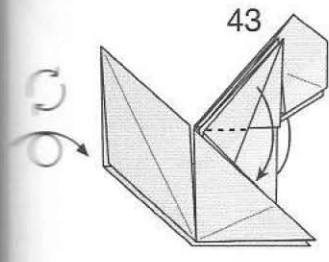

43

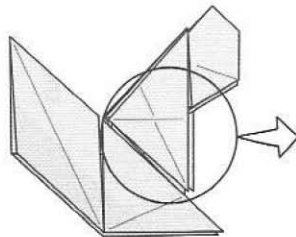

44

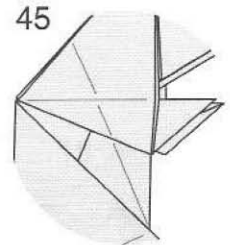

45

中割り折り。

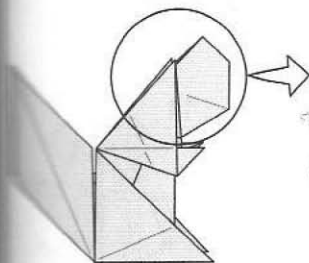

46

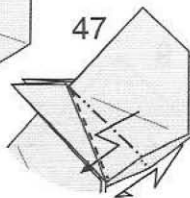

47

両側で斜めに段折り。

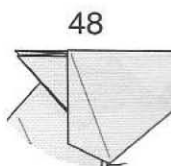

48

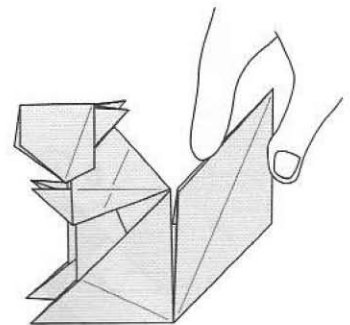

尾を軽くつまんで、少し多面体状にします。

ねずみ Mouse

作/図 中井 努
Design & Diagrams
by Tsutomu Nakai

創作 2007年12月
作図 2008年 6月

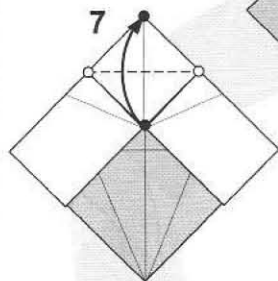
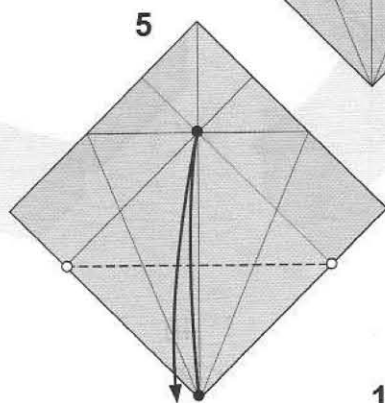
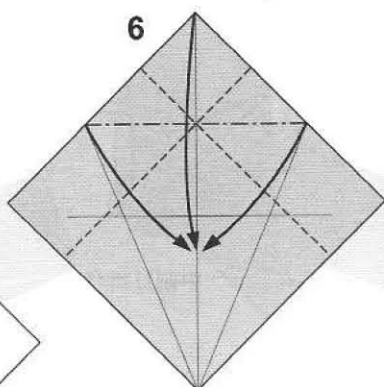
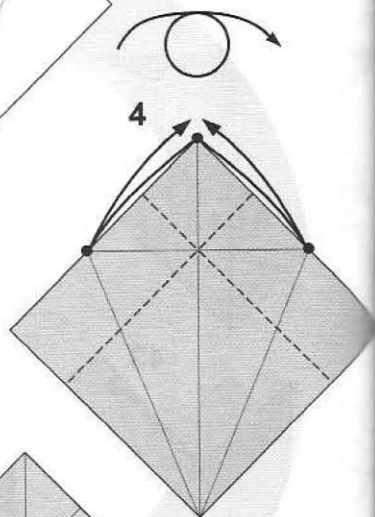
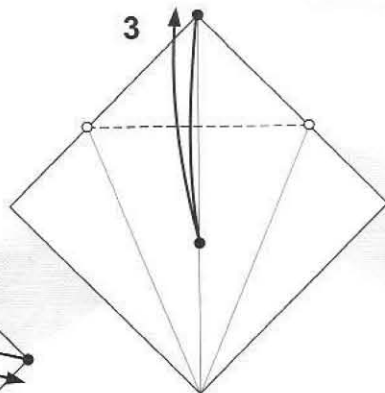
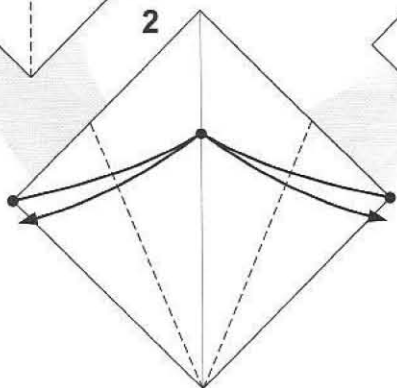
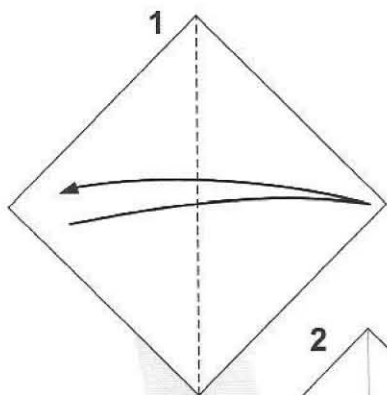

工程3-4の
折り筋でまとめる

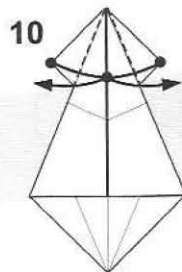
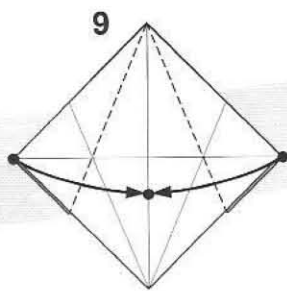
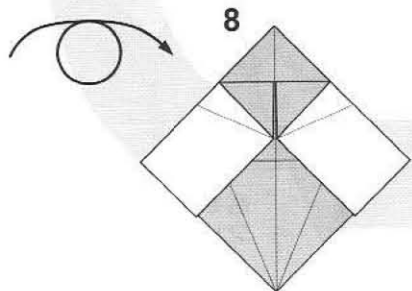

手前の線にあわせる

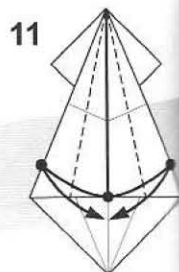

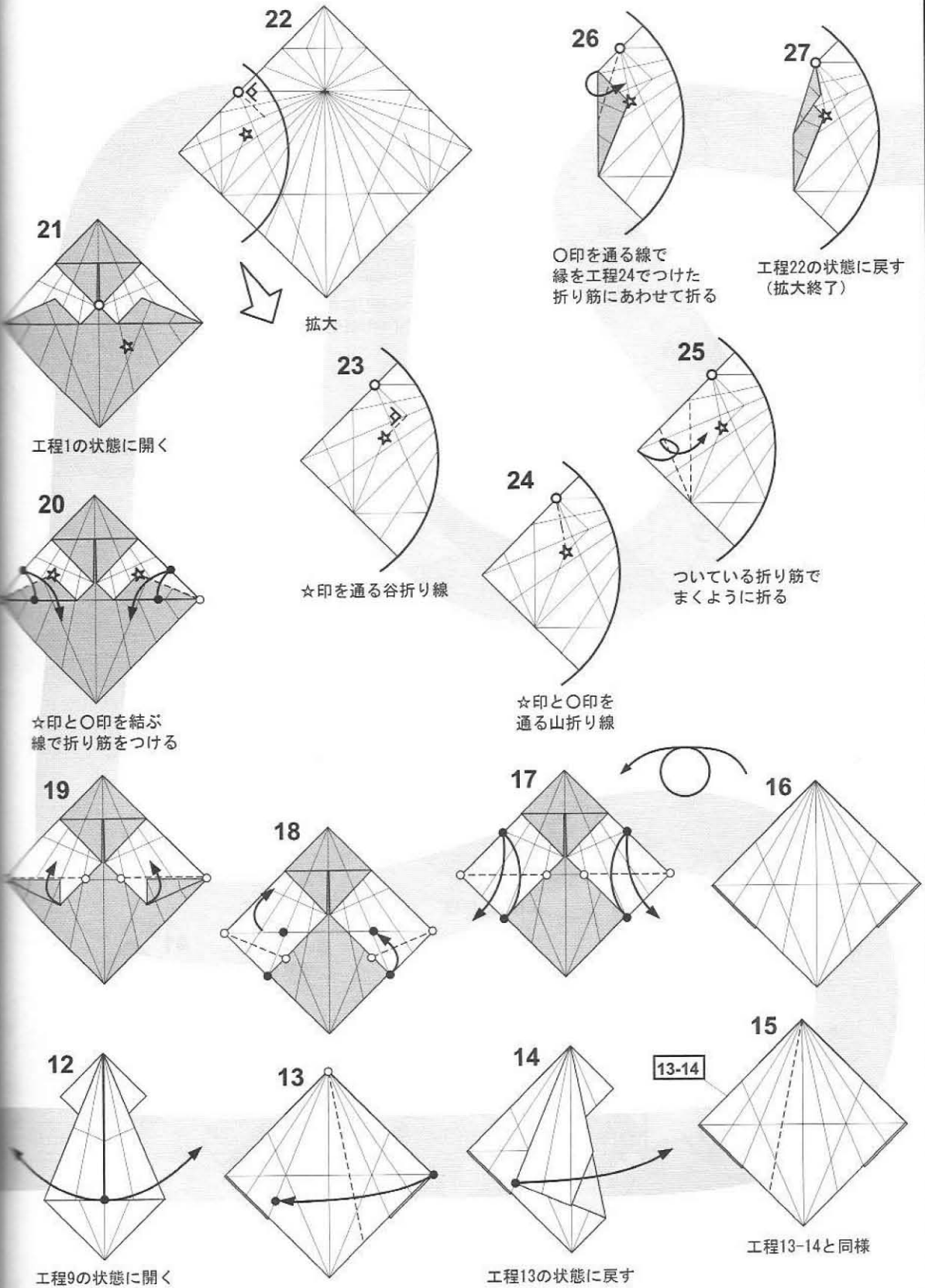

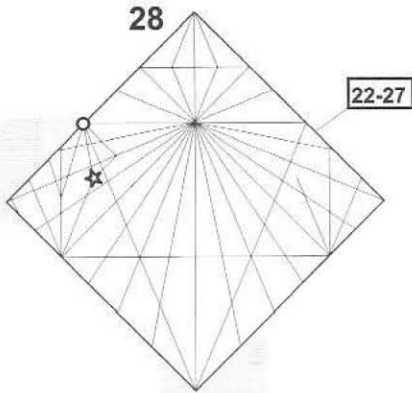

工程22-27と同様

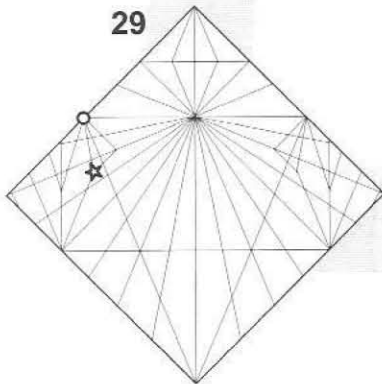

工程21の状態に戻す

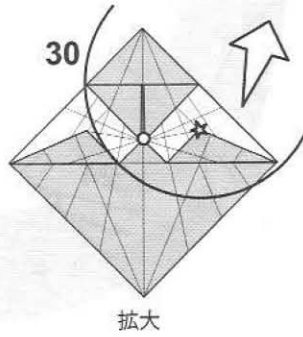

拡大

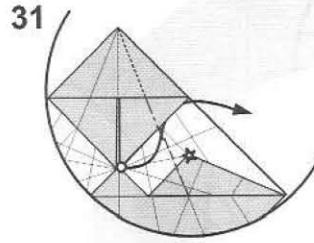

ついている折り筋を利用して中割り折り

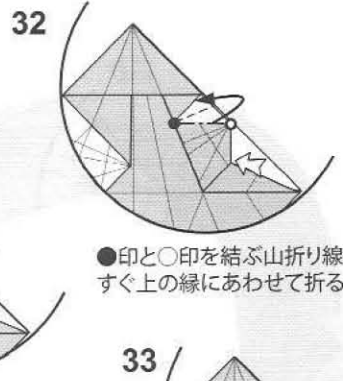

●印と○印を結ぶ山折り線をすぐ上の縁にあわせて折る

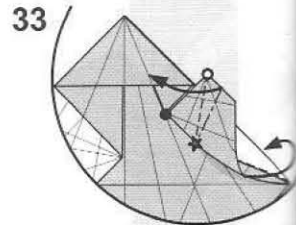

☆印と○印を結ぶ線を谷折り引き寄せて平らにまとめる

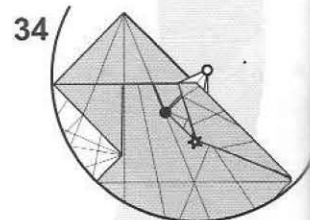

工程32の状態に戻す

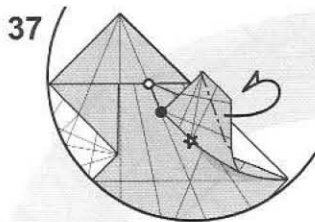

既についている線で山折り

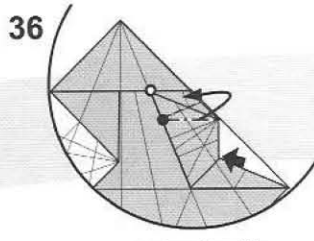

工程32と同様

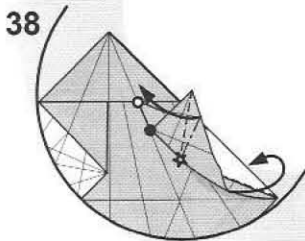
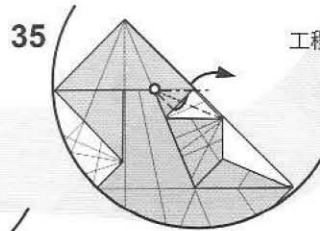

工程33と同様

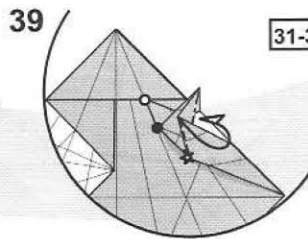

山谷を入れ替え後ろに送る

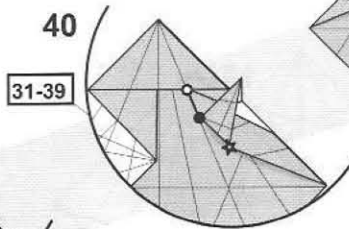

工程31-39と同様 (拡大終了)

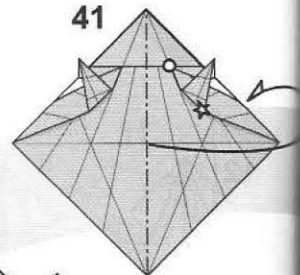

54

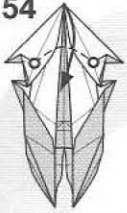

○印を結ぶ線で折り下げる
(積極的な折り筋をつけない)

55

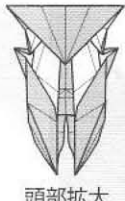

頭部拡大

62

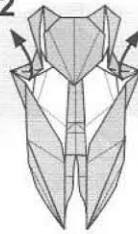

細く折る

61

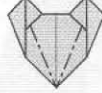

顔を細くする
(全体表示)



同時に耳がおきる

53

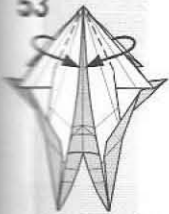

手前の層だけ
内側に折る

56



裏側の紙も
あわせて折る

60

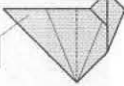

56-59

59

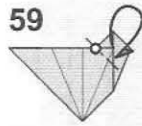

○印を通る山線で
後ろに折りこむ

63

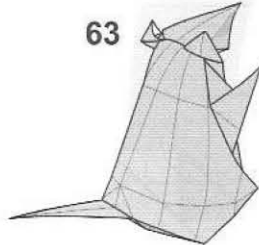

できあがり

52

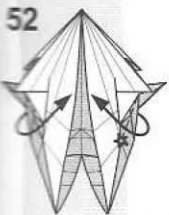

☆印を通る線で
内側に折る

57

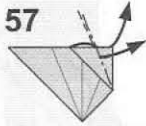

開いてつぶす

58

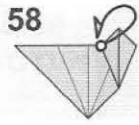

山谷を入れかえて
○印の角を後ろに
おく



尾の付け根は
こんな感じ

51

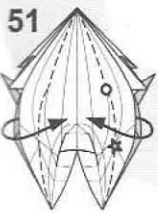

既にある折り筋で
内側に折る

50

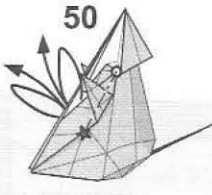

内側の1層のみ
○印と☆印の間に
新しい折り筋
(視点変更)

49

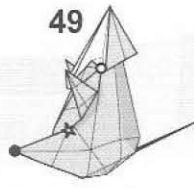

工程48に戻す

48

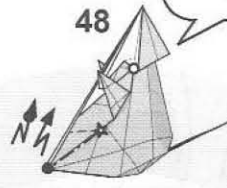

●印と☆印の間に
折り筋をつけ、
☆印が外側に凸に
なるように引寄せ
(手前・奥共に2層)

ここから
立体的な工程

47

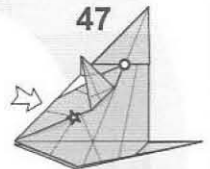

白矢印の側から見て
2層ずつに広げる

42

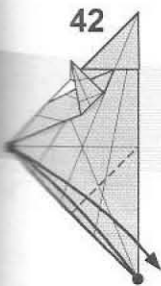

43

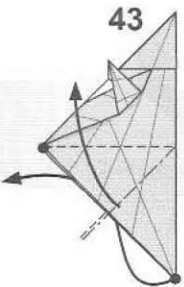

開いて潰す

44

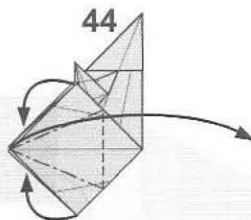

開いて潰す

45

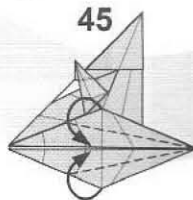

46

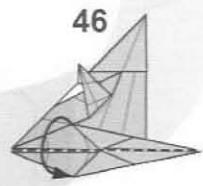

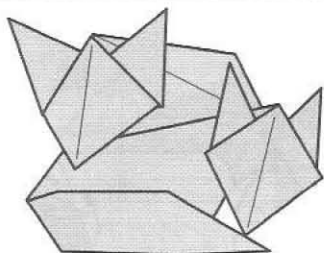

なかよしキツネ
 Playing foxes
 Yoshio Tsuda
 created December 2007

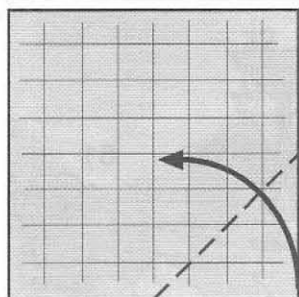

1. 縦横に8等分する。
 角を中心に合わせて折る。

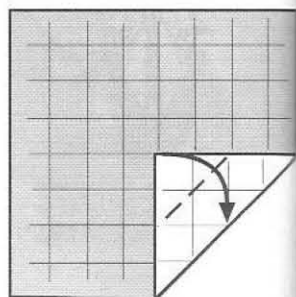

2. 折り返す。

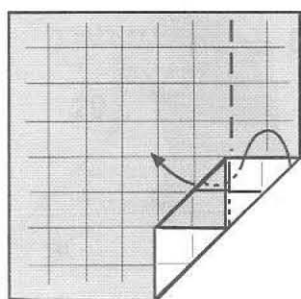

3. 折線のように中わり折りする。

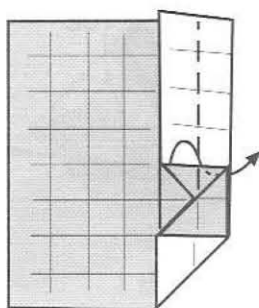

4. 中わり折りを繰り返す。

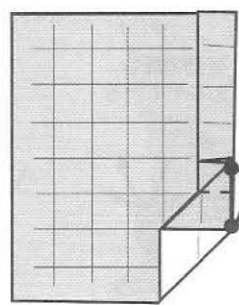

5. 角を尖らせるように
 折り下げる。

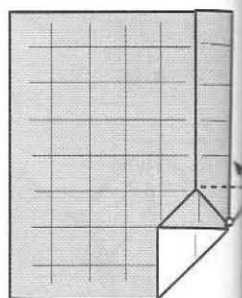

6. 角を上に戻す。

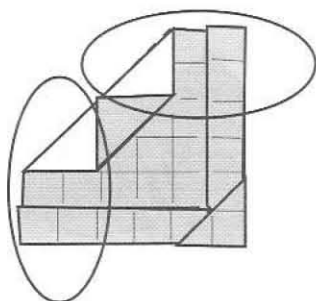

9. 丸で囲んだ部分を
 3-8と同様に折る。

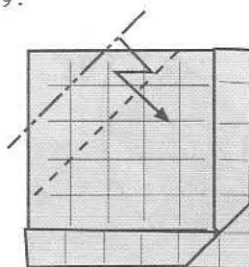

8. 段折りする。

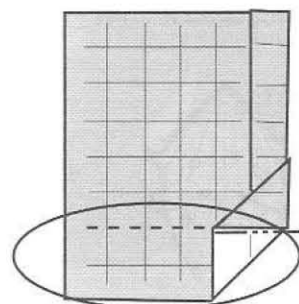

7. こちら側も 3-6と同様に折る。

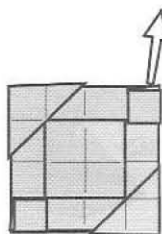

10. 角の重なりを解いて
 細長く折りたたむ。

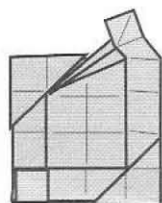

11. 途中経過

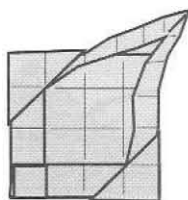

12. 途中経過

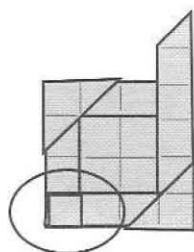

13. こちら側も同様に
 角を引き出すように
 折りたたむ。

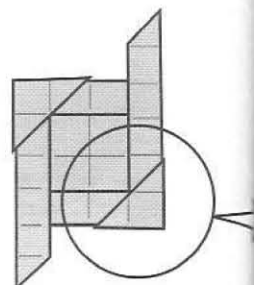

14. 頭部を折る。

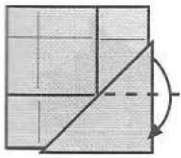

14-1. 角を折り下げる。

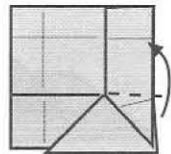

14-3. 角を折り上げる。

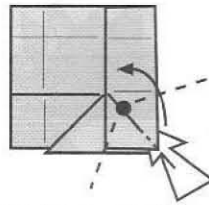

14-5I 黒丸をへこませる
ようにして中わり折りする。

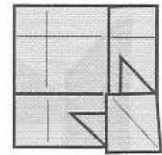

14-7.

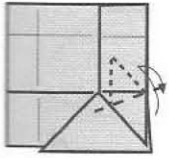

14-2 点線を目安に
折り線をつける。

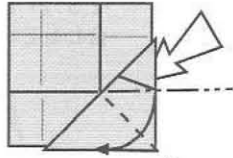

14-4. 下のポケットを開いて
角を広げ、折り下げる。

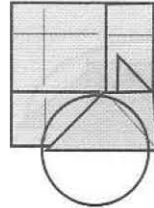

14-6. こちら側も同様に折る。

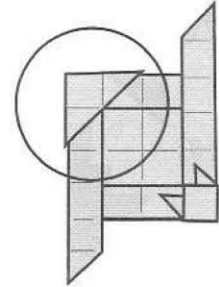

15. こちら側も 14-1 から
14-7 と同様に折る。

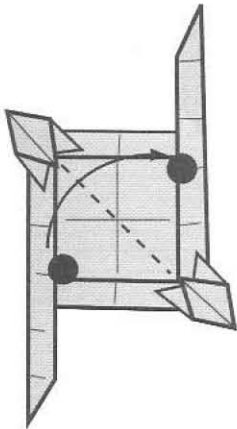

18. 黒丸を合わせるように
対角線に沿って全体を
折りたたむ。

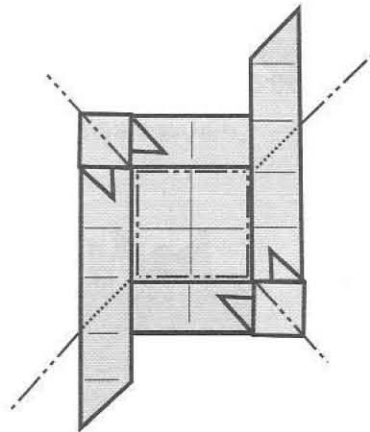

17. 折線のように折って立体にする。

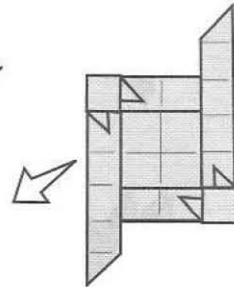

16.

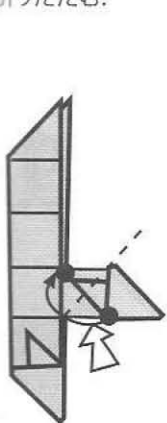

19. 一番上の隙間を開き、
黒丸を合わせて折る。

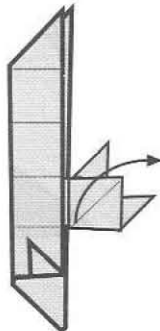

20. 上に持ち上げる。

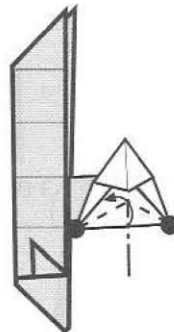

21. 中の三角の角 2カ所を
重ねたまま折線のように
半分折りたたむ。

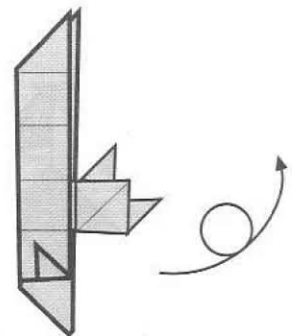

22.

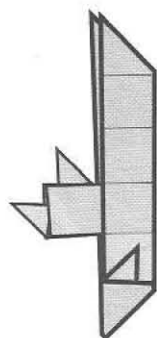

23.

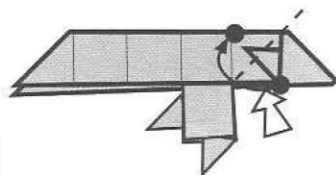

24. 19 - 22と同様に折る。

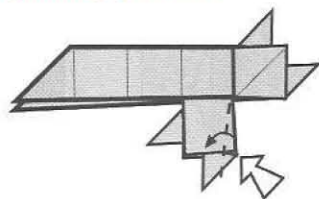

25. 21で折った内側の縁に合わせて折る。

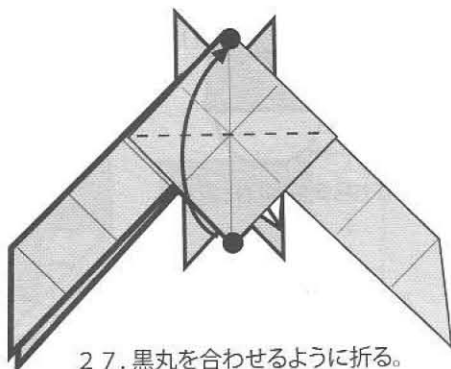

27. 黒丸を合わせるように折る。

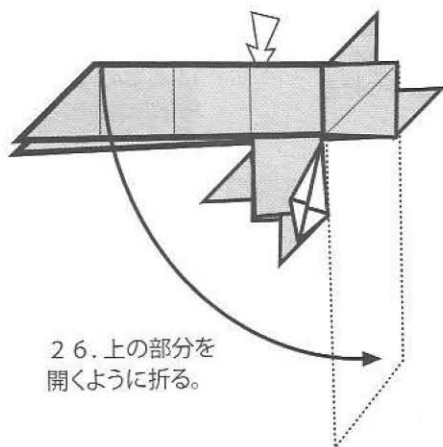

26. 上の部分を開くように折る。

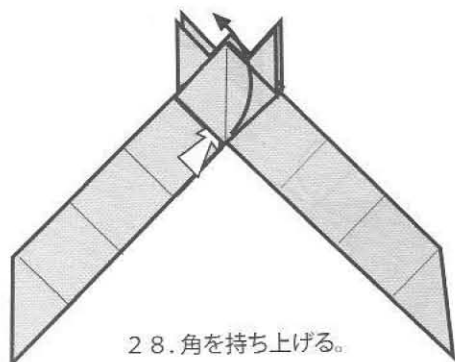

28. 角を持ち上げる。

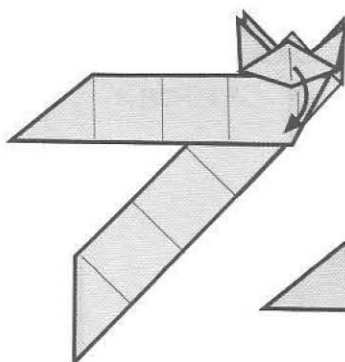

30. 角を元に戻す。

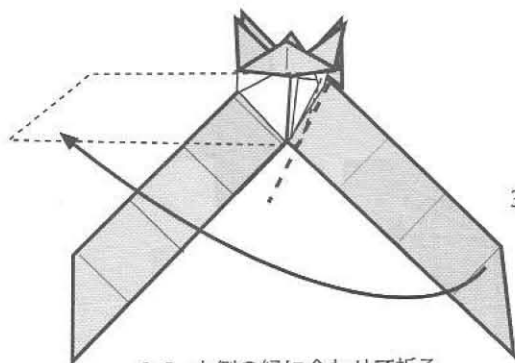

29. 内側の縁に合わせて折る。

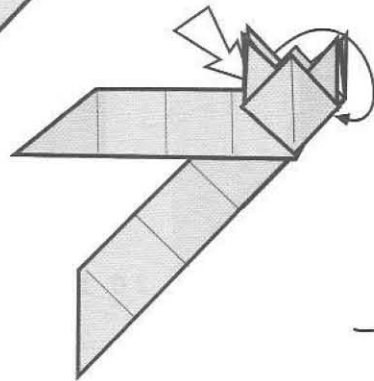

31. 裏面の頭部を次図のようにひねるようにして手前に折る。

9

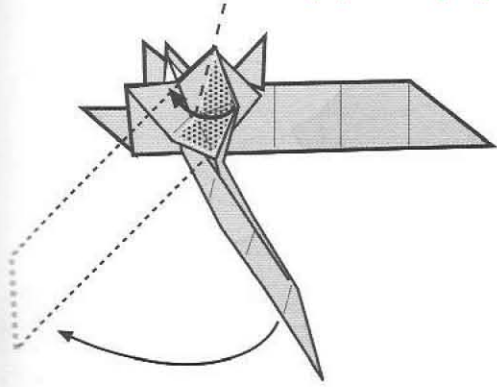

32. 網かけした部分が平らになるように開いておる。

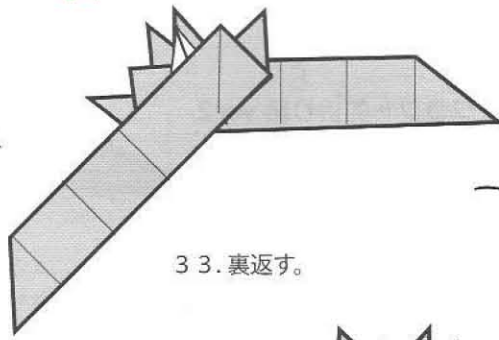

33. 裏返す。

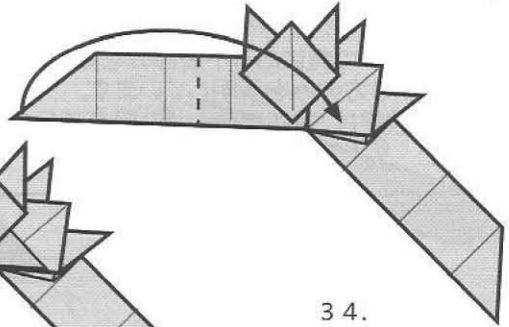

34.

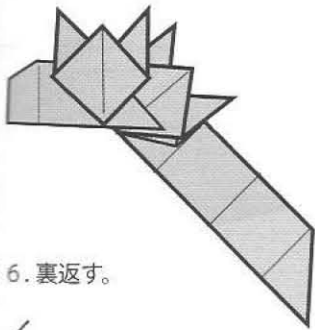

36. 裏返す。

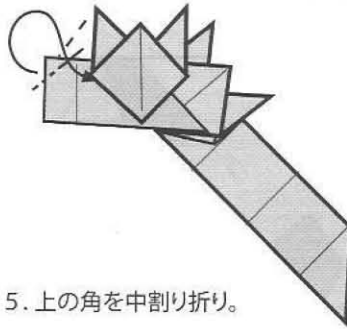

35. 上の角を中割り折り。

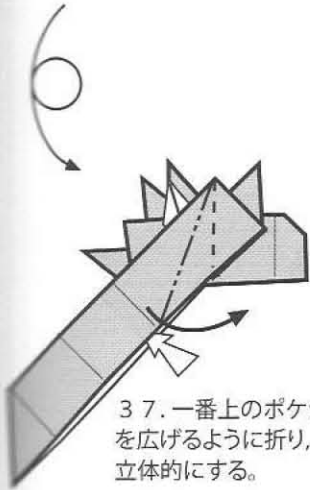

37. 一番上のポケットを広げるように折り、立体的にする。

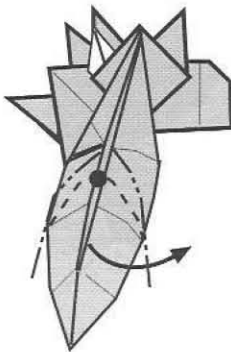

38. 折線のように黒丸の部分を内側に折り込む。

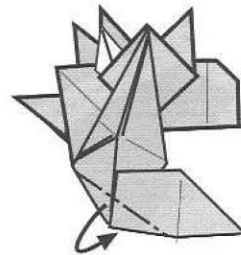

39. 全体をひねるように折る。

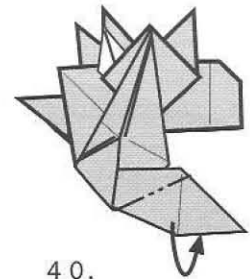

40.

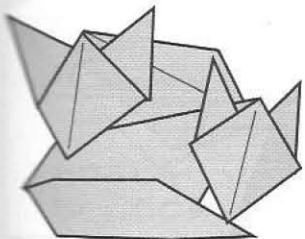

完成

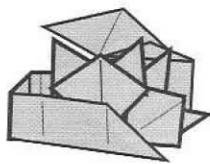

42. 形を整える。



41.

イルカ

ペーパークラフト的折り紙 ver.2

Tanaka Masahiko, 2008-06

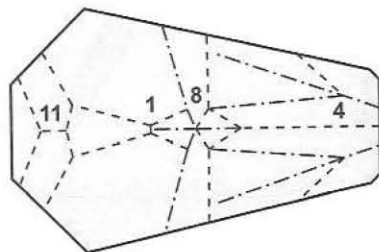
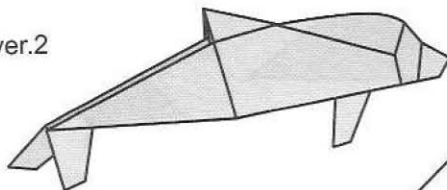

下の展開図の折り線をトレースしてから折り始めます。
用紙の4つの角にある不要部分を除いた右図の形
からの折り方のみを説明しています。
図中の数字は、対応部分の折り図の番号です。

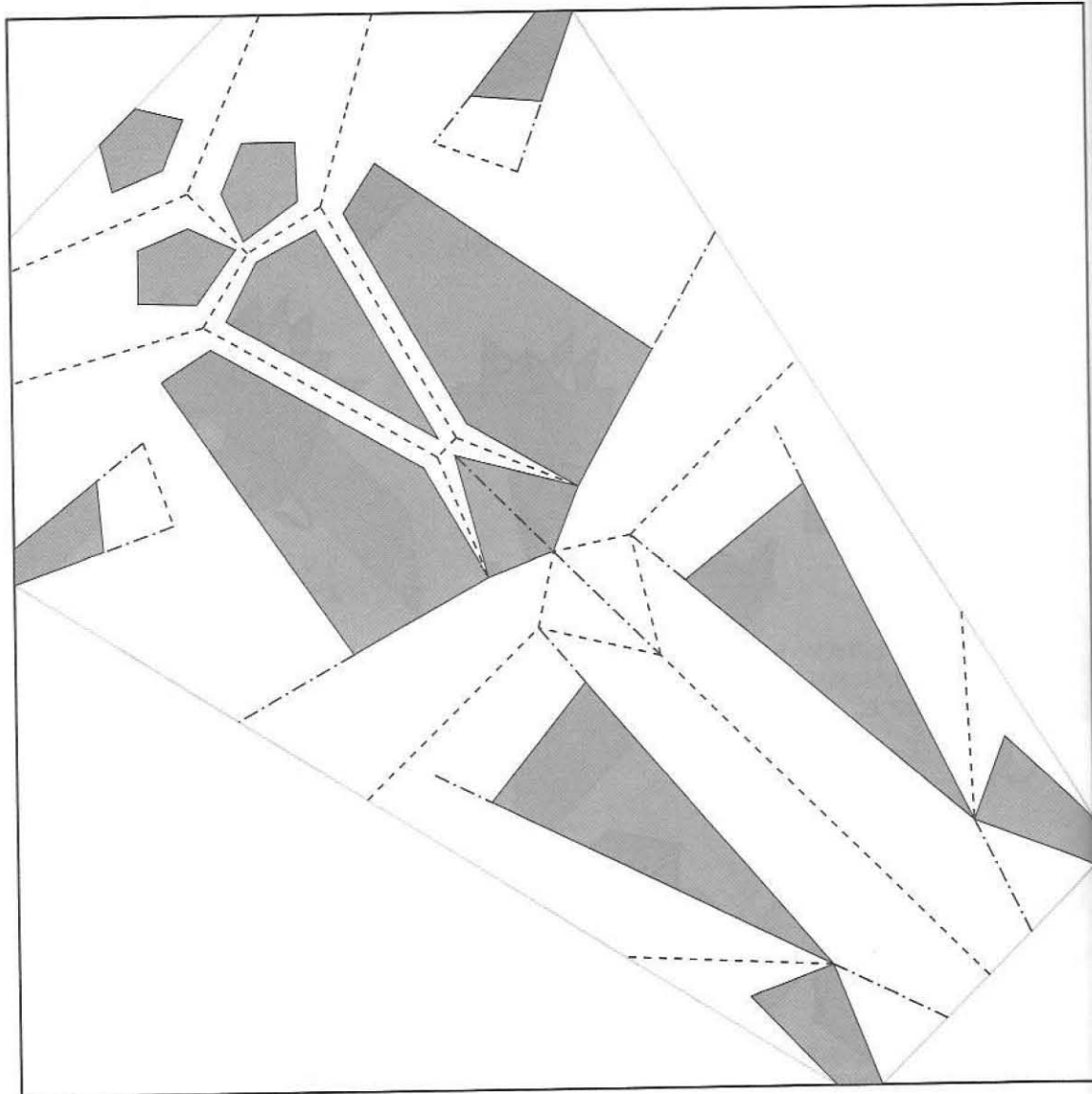

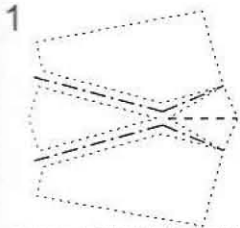

1
4本の折り線を内側から
つまむように折る

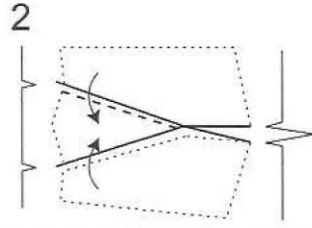

2
2つのヒダを内側にたおす

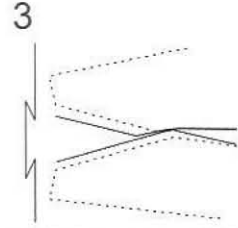

3
おりすじをしっかりつけて
もとにもどす

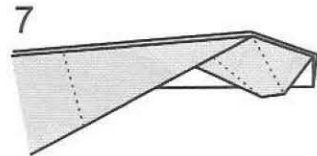
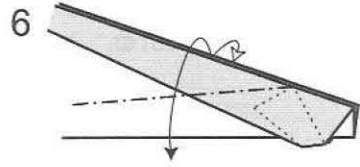
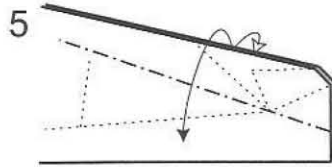
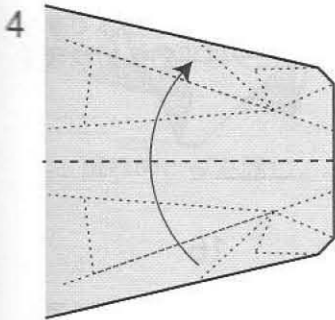

7
おりすじをしっかりつけて
もとにもどす

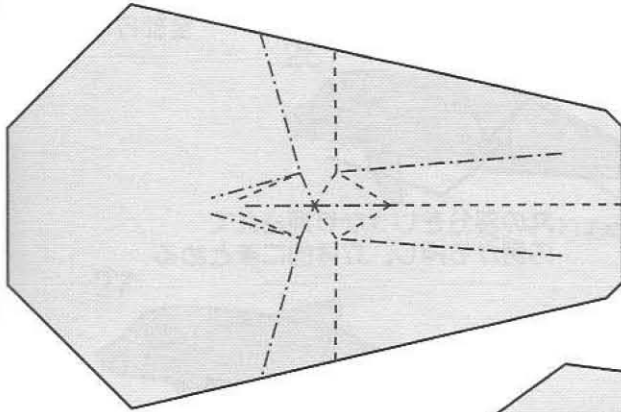

8
おりすじどおりにまとめる

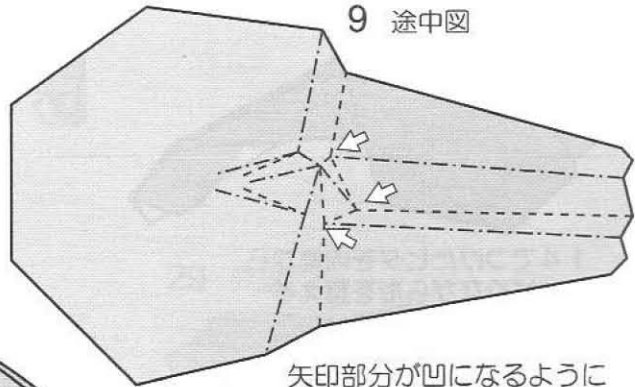

9 途中図
矢印部分が凹になるように

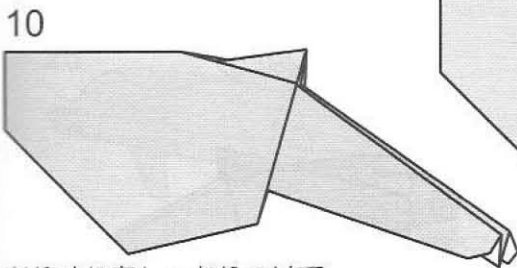

10
おりすじをしっかりつけて
もとにもどす

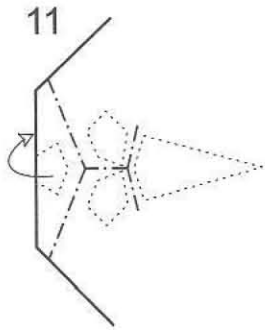

11
5本の折り線を内側から
つまむように折る

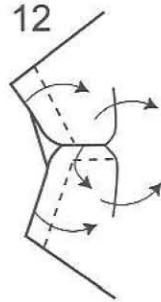

12
ひだを矢印方向にたおす



13
全体としては立体ですが
各ヒダは平らに折れます

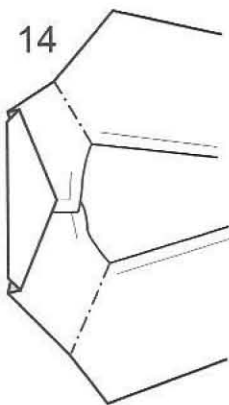

14
1でつけた折りすじと交わる点から
つまむようにヒダをつくる

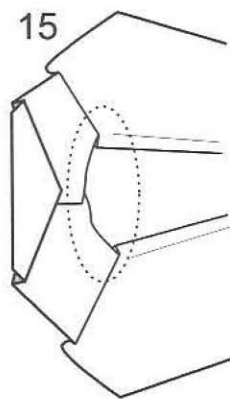

15
丸の部分をしっかり押さえて
内側から押し、立体的にまとめる

16
もどしておいた
1~10の折りを
全部行う

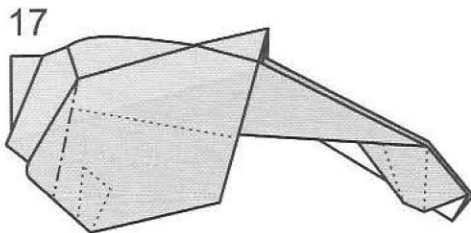

17
14でつけたヒダを内側から
ひっぱりながら形を整える

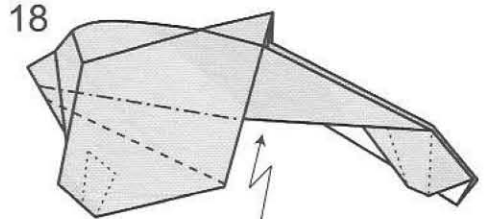

18
内側へ段折り

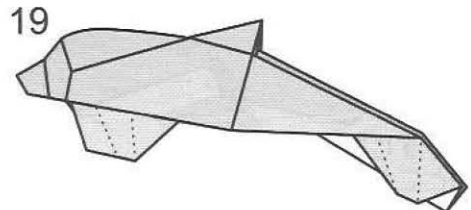

19

20 内側をみる

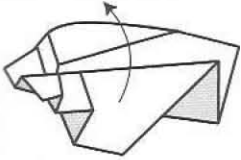

かるくもどす

21

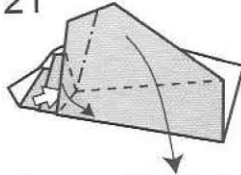

矢印のヒダを縁にあわせながら
引き寄せ折り

22

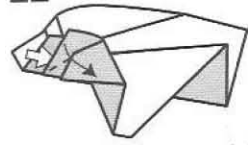

次のヒダも同様に折る

23

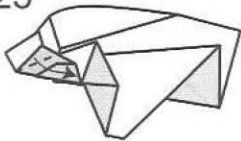

残りのヒダも同じ

24

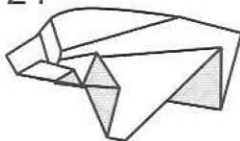

Japão Burajirujin

www.japaoburajirujin.blogspot.com

25

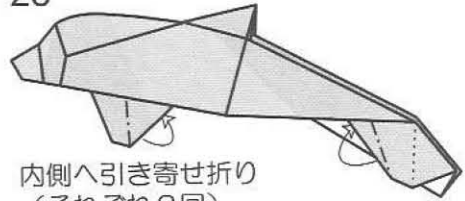

内側へ引き寄せ折り
(それぞれ2回)

26

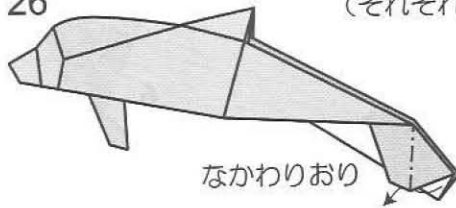

なかわりおり

27

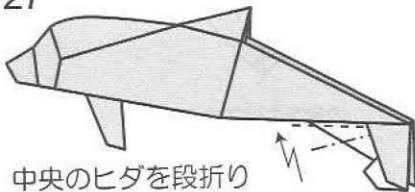

中央のヒダを段折り

28

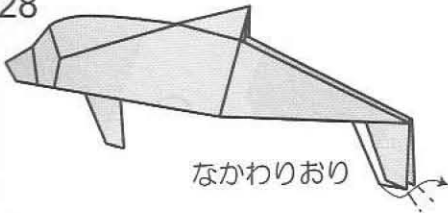

なかわりおり

29 完成

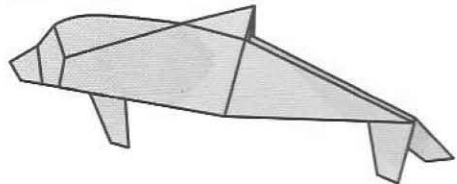

カンガルー Kangaroo

創作・作図 萩原元

Design & Diagram Gen Hagiwara

Japão Burajirujin

www.japaoburajirujin.blogspot.com

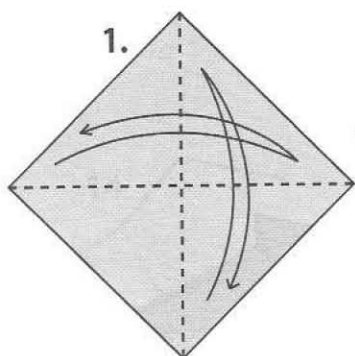
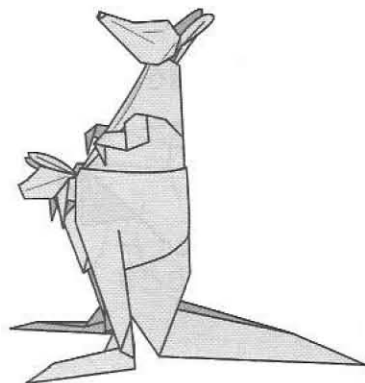

1. 折り筋を付ける

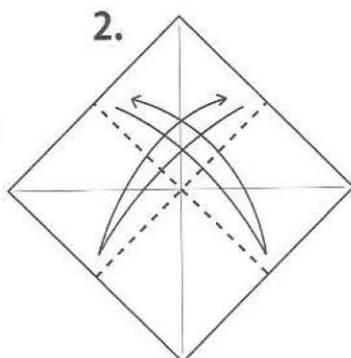

2. 折り筋を付ける

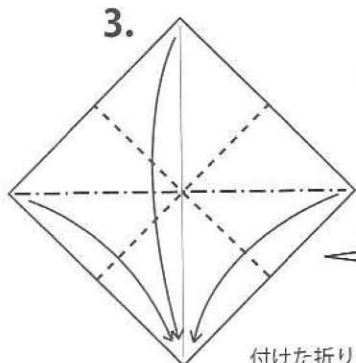

3. 付けた折り目
折り畳む

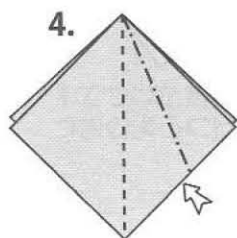

4. 内側を広げてつぶす

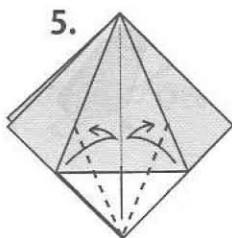

5. 縁を中心に合わせて
折り筋を付ける

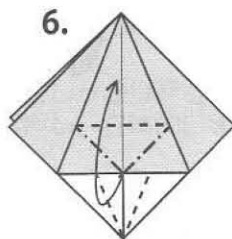

6. 内側を広げてつぶす

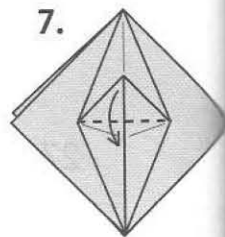

7. 折り下げる

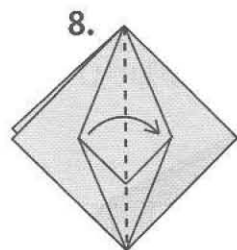

8. カドを右側に倒す

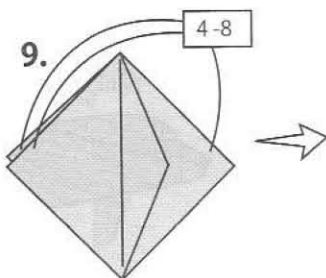

9. 残り3つも
同様に折る

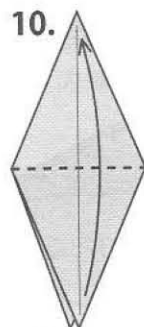

10. カドを一つ
折り上げる

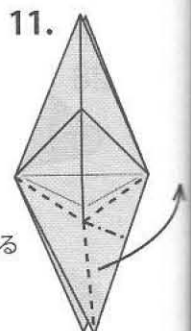

180°回転させる

11. つまみ折り

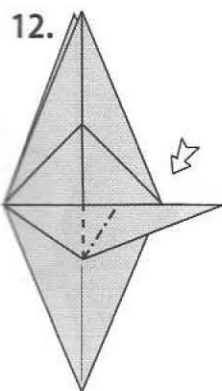

12. 内側を開いてつぶす

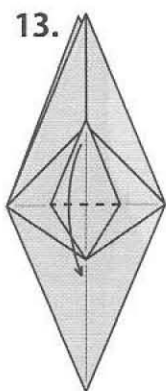

13. カドを折り下げる

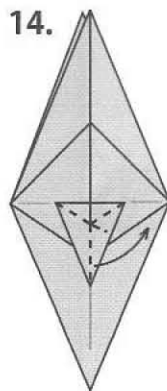

14. つまみ折り

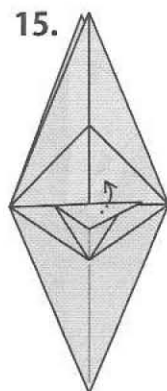

15. 紙を内側から引き出す

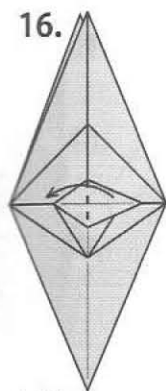

16. カドを左側に倒す

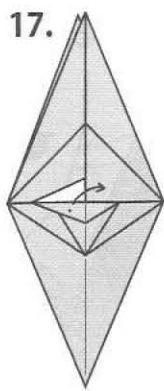

17. 紙を内側から引き出す

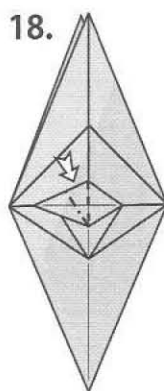

18. 内側を広げてつぶす

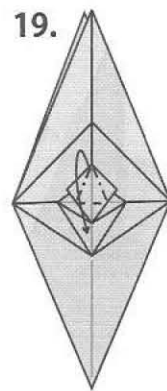

19. 開いてつぶす

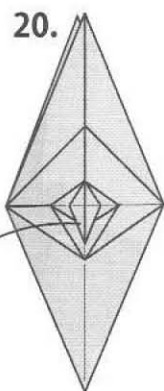

20. 14. から 17. と同様の方法でカドを折る

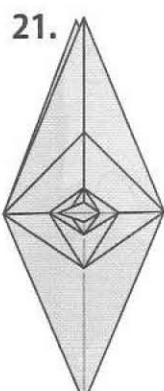

21.

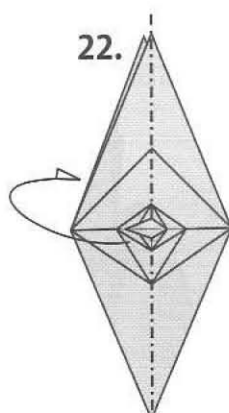

22. 全体を半分に分ける

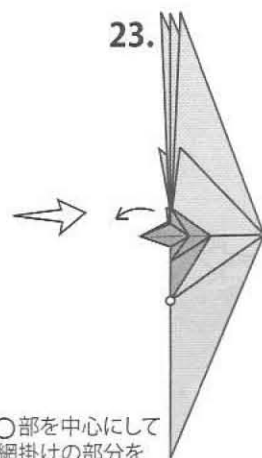

23. ○部を中心にして網掛けの部分をずらすように折る
角度は次の図を参照

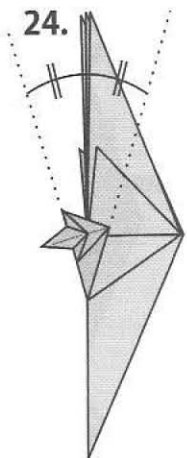

24.

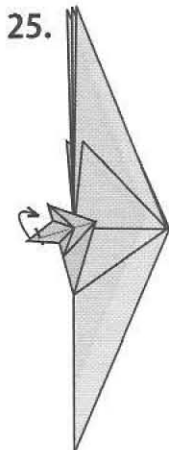

25.

中割り折り

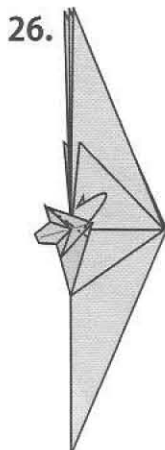

26.

カドを裏側に折る

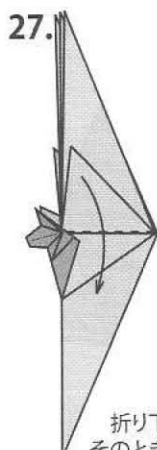

27.

折り下げる
そのとき網掛け部分の
下に入るようにする

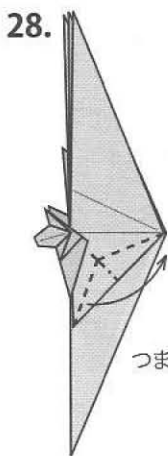

28.

つまみ折り

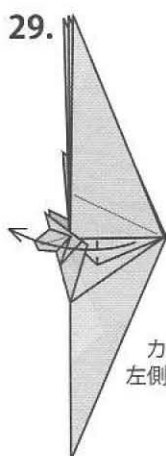

29.

カドを
左側に倒す

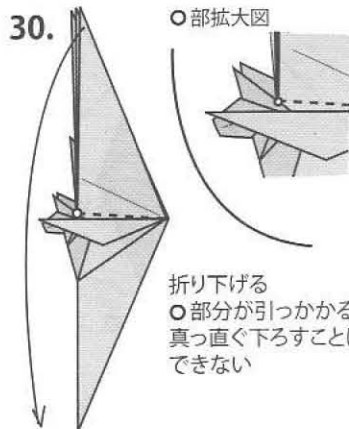

30.

○部拡大図

折り下げる
○部分が引っかかるので
真っ直ぐ下ろすことは
できない

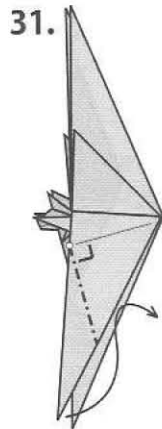

31.

中割り折り

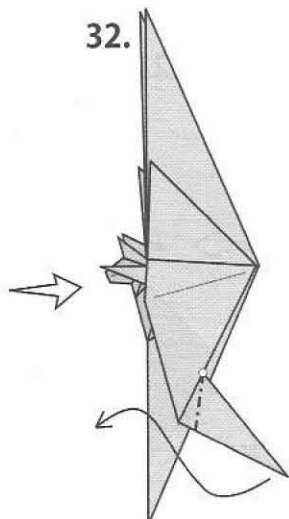

32.

中割り折り
角度は次の図を参照

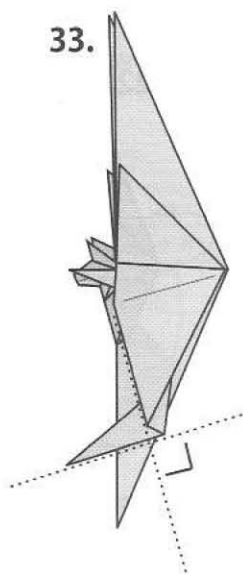

33.

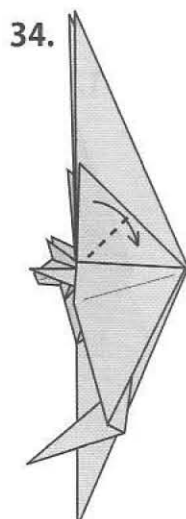

34.

カドを半分にする

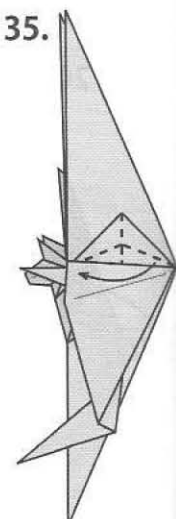

35.

折り下げた部分を
つまみ折り

36.

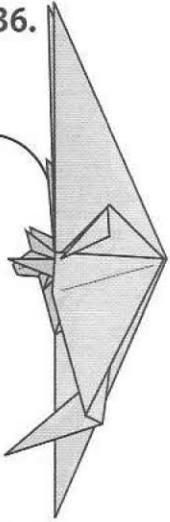

37.

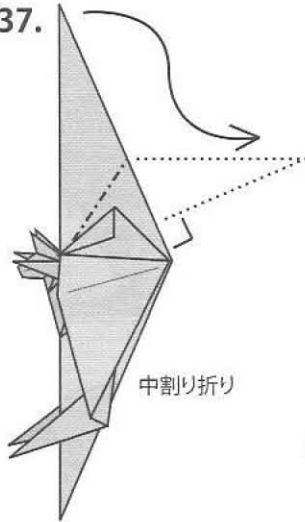

中割り折り

38.

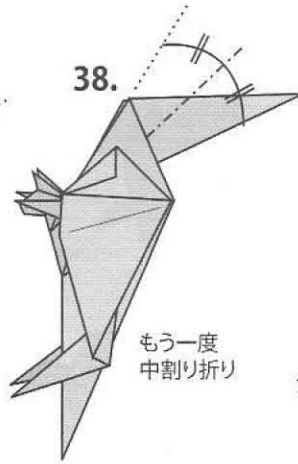

もう一度
中割り折り

39.

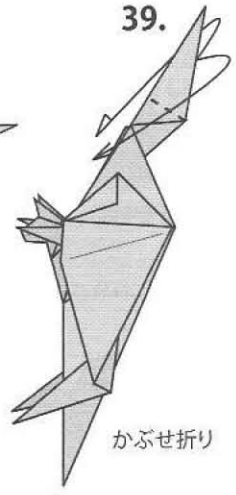

かぶせ折り

反対側も 26. から
34. と同様に折る

40.

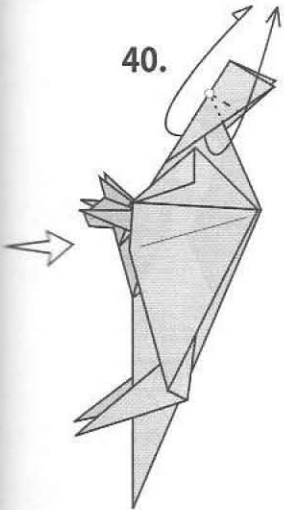

もう一度
かぶせ折り

41.

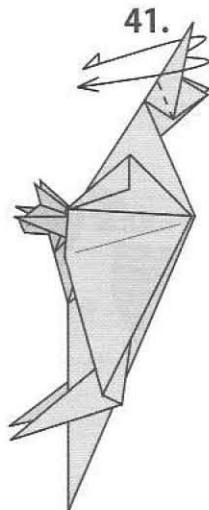

さらに
かぶせ折り

42.

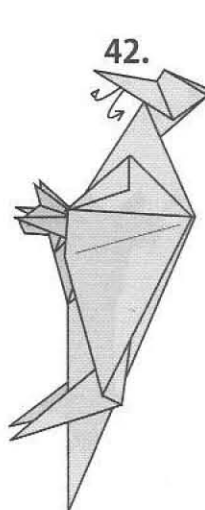

紙を内側
から引き出す

43.

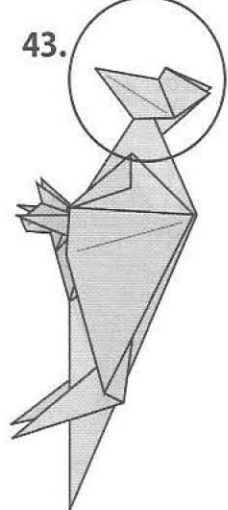

44.

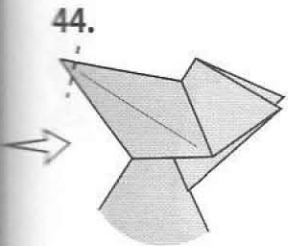

先端をかぶせ折り

45.

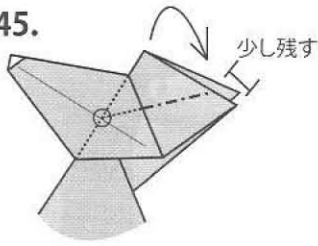

中割り折り

少し残す

46.

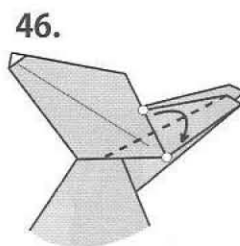

折り筋を付ける

47.

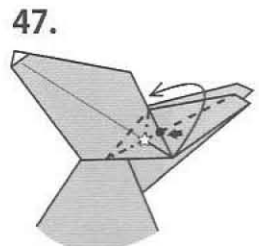

●部分を押し込みながら
折り筋を使ってたたく
☆の場所は凸になる

48.

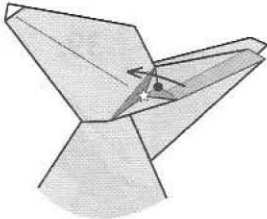

【途中図】

49.

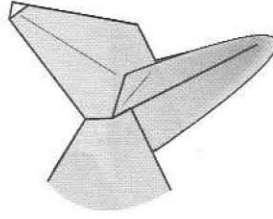

50.

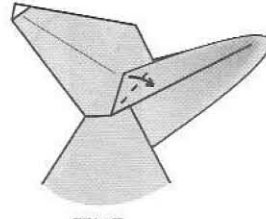

閉じる

51.

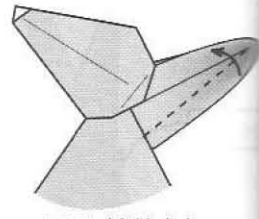

平面に折りたたむ

52.

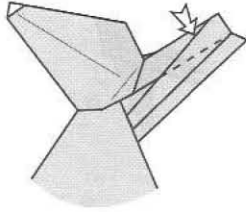

開く

53.

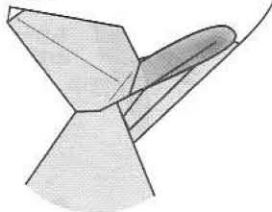

反対側も
同様に折る

54.

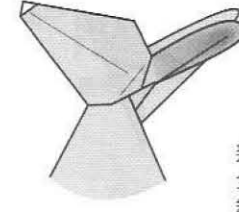

55.

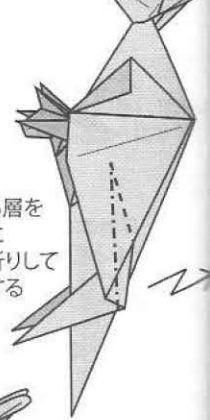

幾つかある層を
全部一緒に
斜めに段折りして
立体的にする

56.

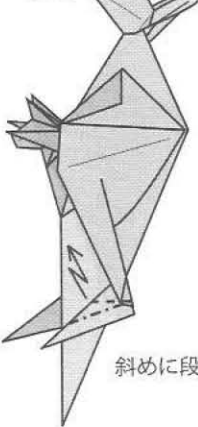

斜めに段折り

57.

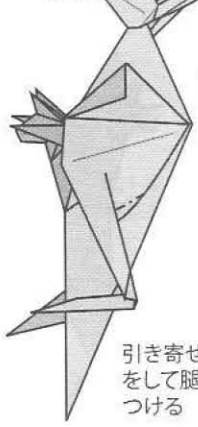

引き寄せ折り
をして腿に丸み
をつける

裏側から見た図

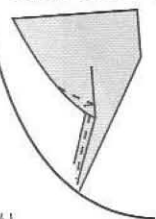

58.

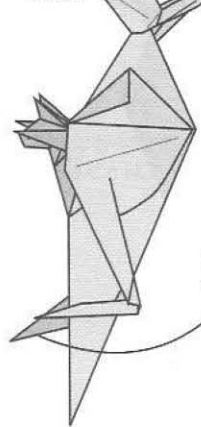

55-57

反対側も
同様に折る

59.

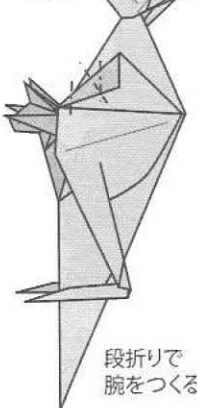

段折り
で腕をつくる

60.

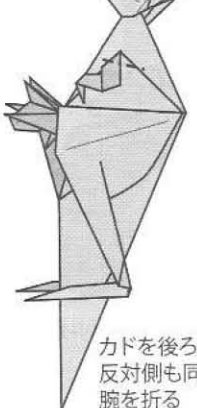

カドを後ろに折り込む
反対側も同様の手順で
腕を折る

61.



子供の腕部
をかぶせ折り
反対側も同様

62.

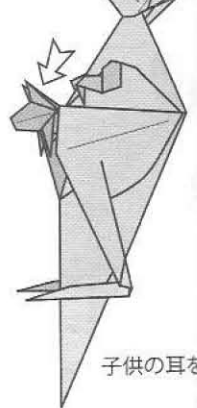

子供の耳を

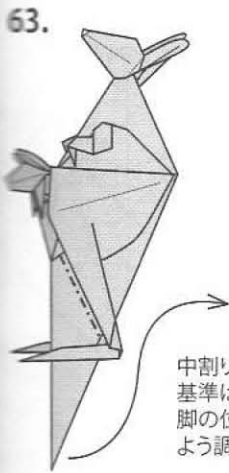

中割り折り
基準はない
脚の位置に合う
よう調節する

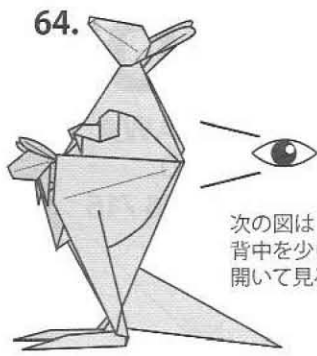

次の図は
背中を少し
開いて見る

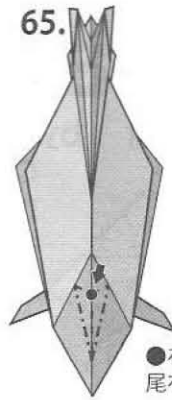

●を押し込みながら
尾を細くする

この作業は結構な力技
なので仕上がりが汚く
なりやすいです
汚くなるのが嫌な方、
尾が太いままでも構わ
ない方は飛ばしてもい
いでしょう

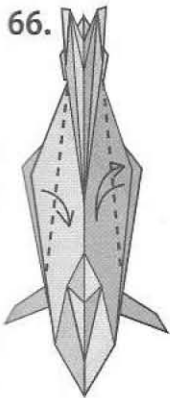

カドを内側に折る
片方は折り筋を付ける
だけで元の位置に戻す

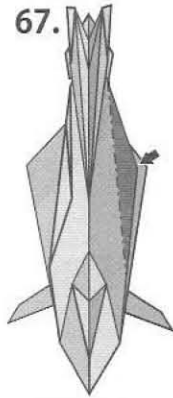

折り筋を使って
沈め折り
(open sink)

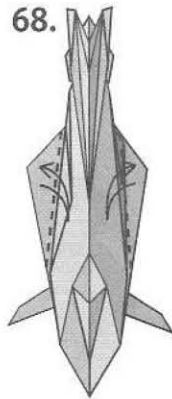

折り筋を付ける

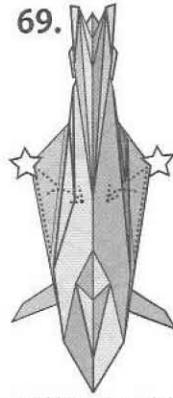

☆の付いているカドの中
にあるカドを折り込む

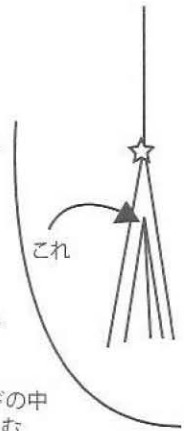

これ

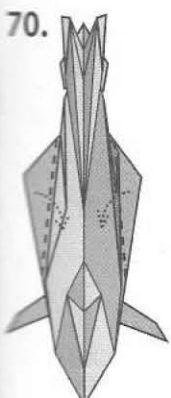

カドを手前の
隙間に入れる

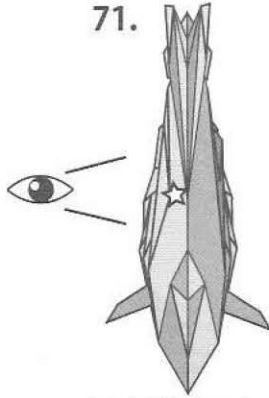

☆のカドを63.で
沈め折りした場所と
噛み合わせて背中を閉じる
次の図から側面からの
視点に戻る



顔を整える
首に丸みを
付ける

脚の形を調整する

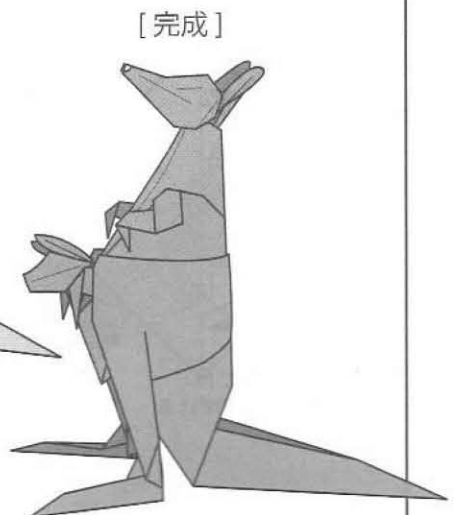

[完成]

15°-Cat 2007

by Seiji NISHIKAWA
Create 2007 /10
Diagram 2008 /06 /15



図 45 の展開図



図のように
○の交点を通る
ようにおりすじを
つける

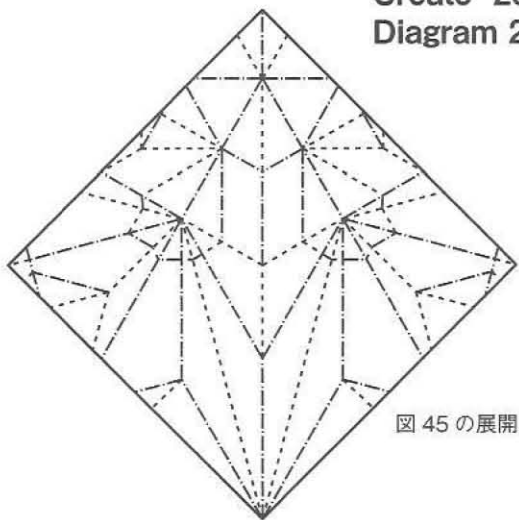
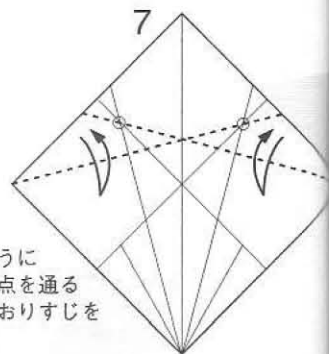
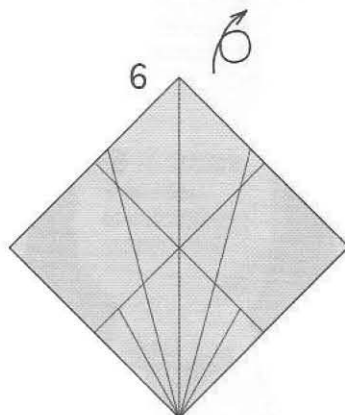

反対側も
3-4と同様に

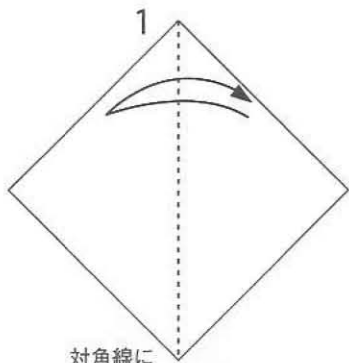
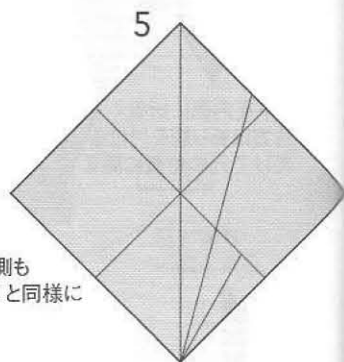

対角線に
おりすじをつける

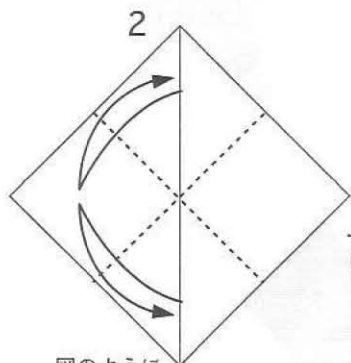

図のように
おりすじをつける

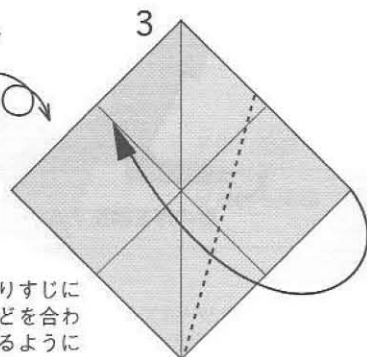

おりすじに
かどを合わ
せるように
折る

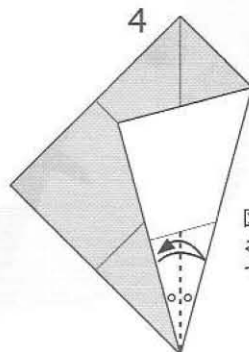

図のように
おりすじを
つける

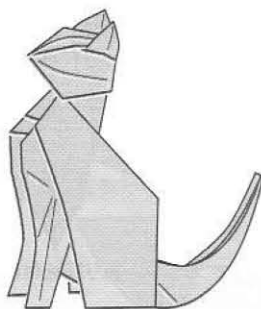

© SEIJI NISHIKAWA

It is prohibited hard to improve the diagram the web without permission.

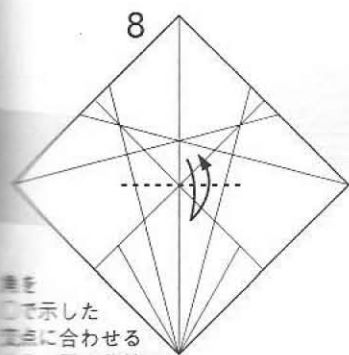

角を
○で示した
交点に合わせる
ように図の谷線の
折りすじをつける

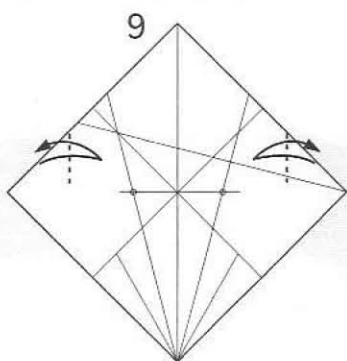

9でつけた
折りすじを
中央の対角線に
合わせるように
図の○の交点を通る
谷線の折りすじをつける。

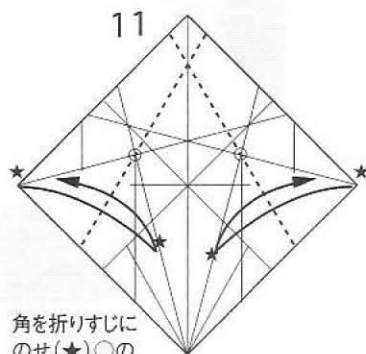
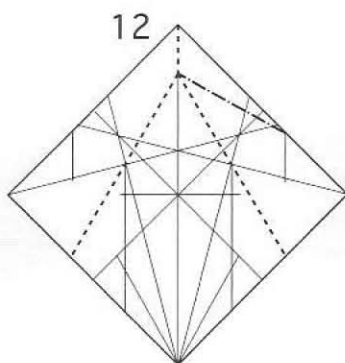
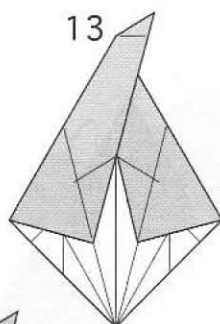
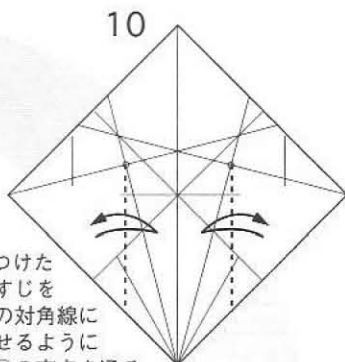

角を折りすじに
のせ(★)○の
交点を通る谷線
の折りすじをつける。

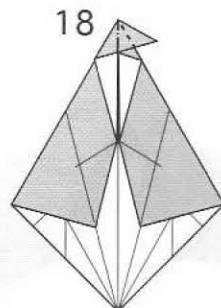
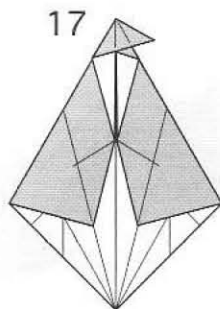
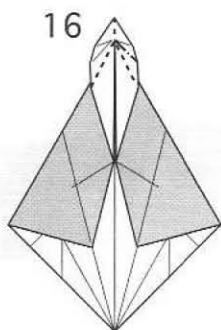
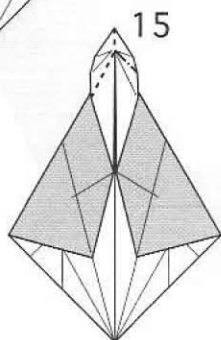
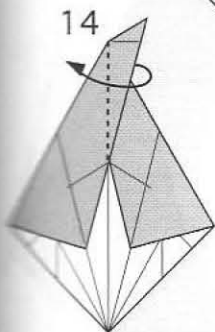

飛び出した角を
内側に入れる

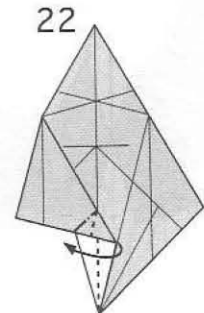
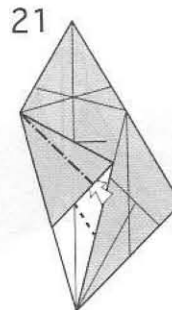
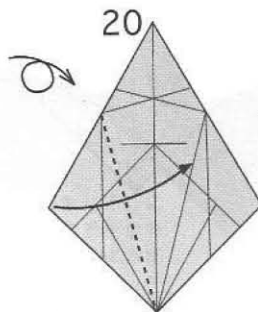
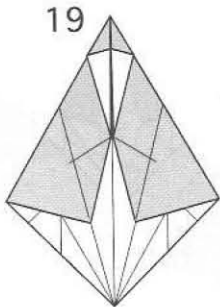
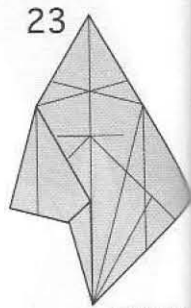
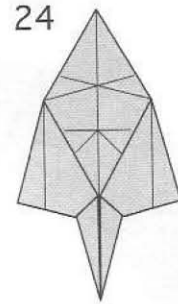
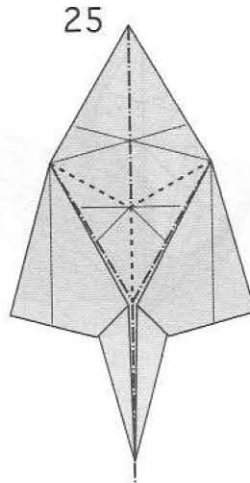
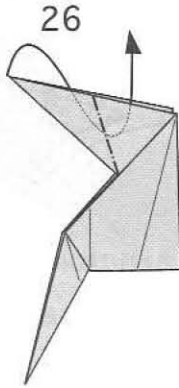
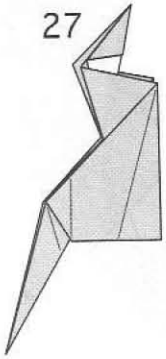
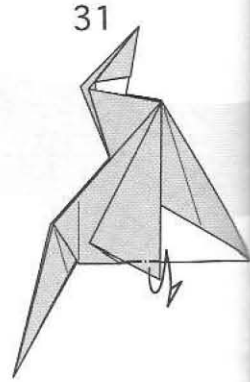
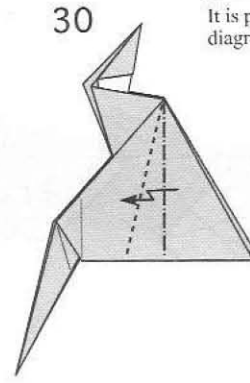
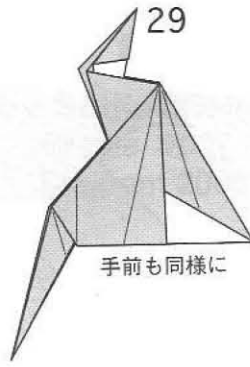
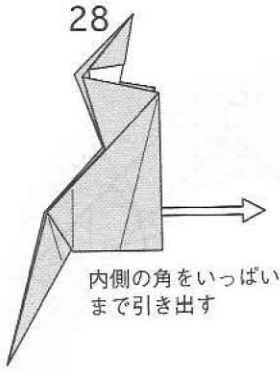

反対側も
20 - 22
同様に

© SEIJI NISHIKAWA

It is prohibited hard to improve the diagram on the web without permission.

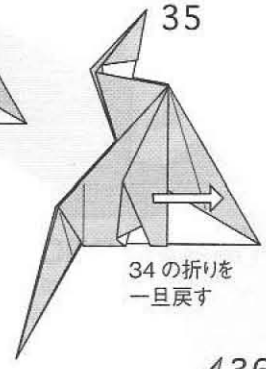
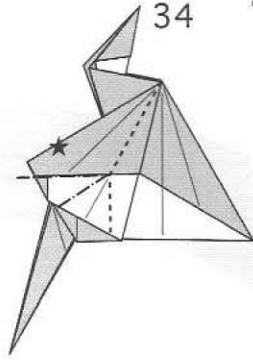
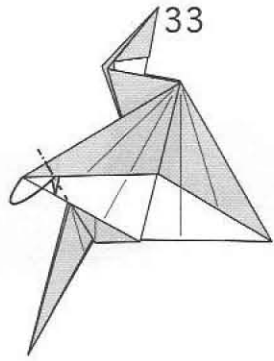
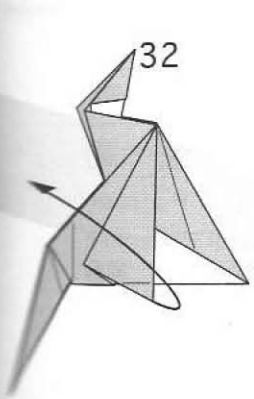

34の折りを一旦戻す

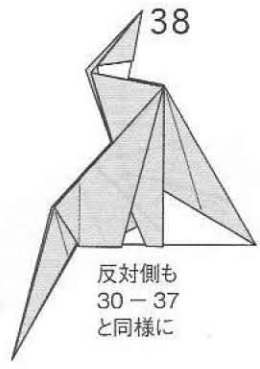
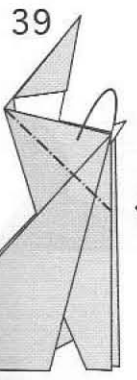
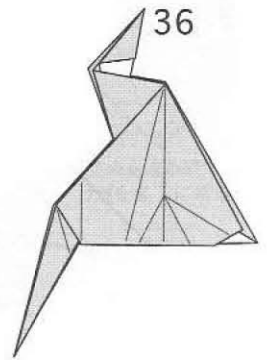

反対側も
30-37
と同様に

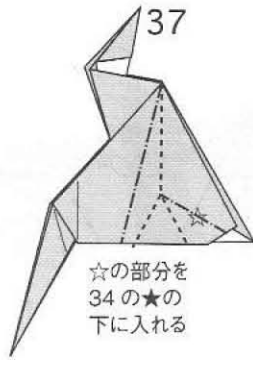

☆の部分を
34の☆の
下に入れる

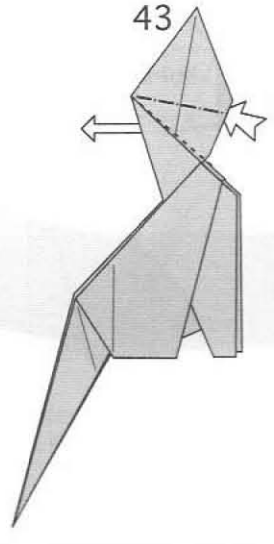
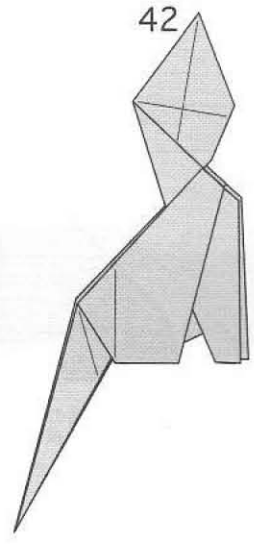
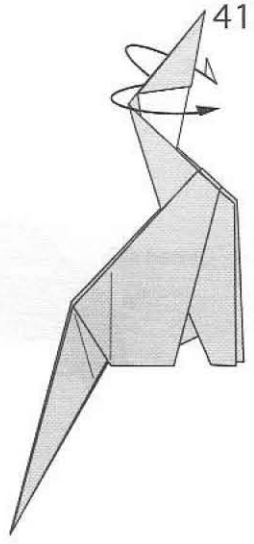
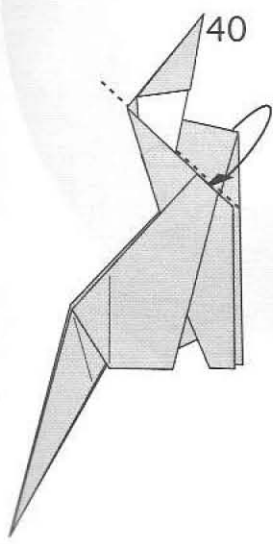

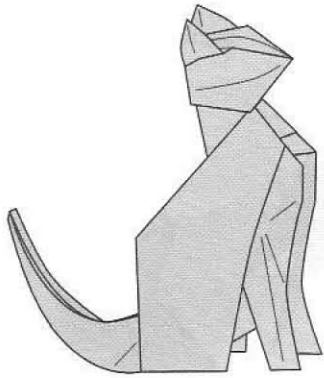

15°-Cat 2007
できあがり

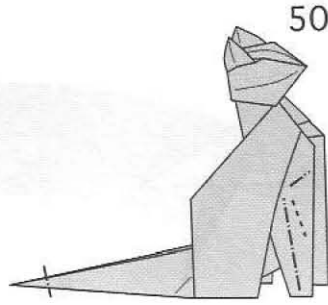

50

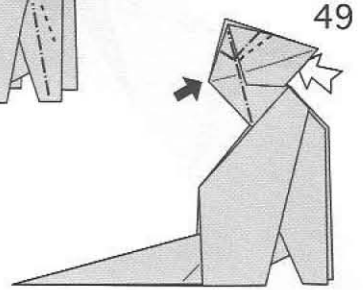

49

耳を段折りしながら
頭を下から開き、
首の後ろを押し込む

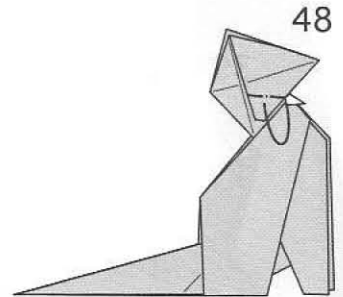
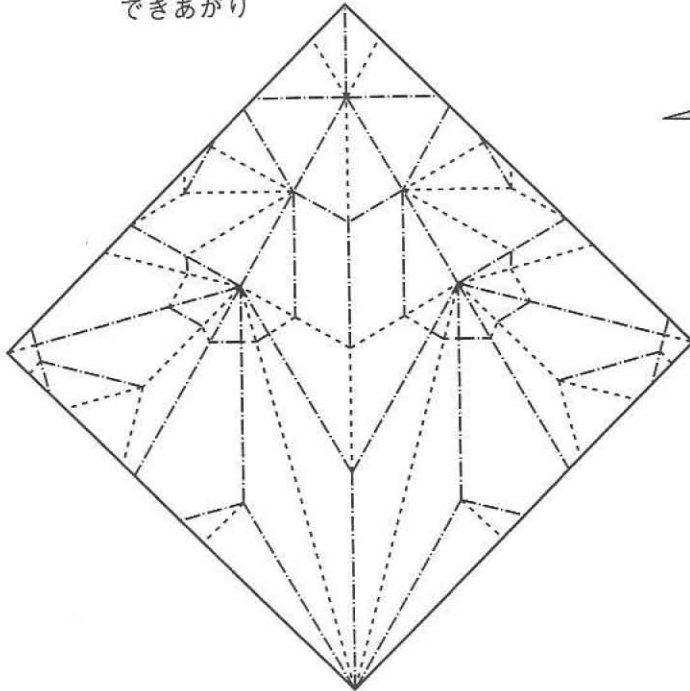

48

途中図 44

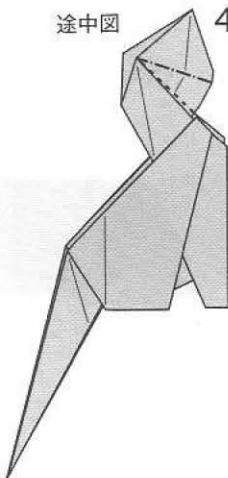

45

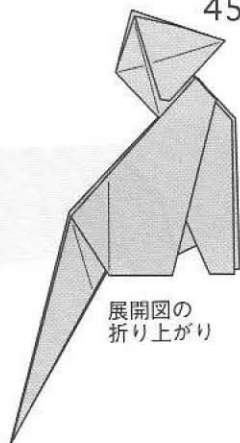

展開図の
折り上がり

46

Closed sink

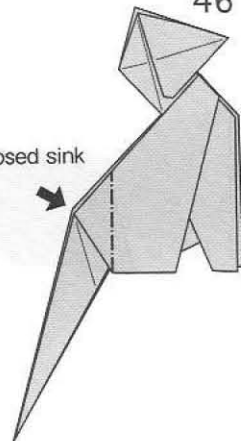

47

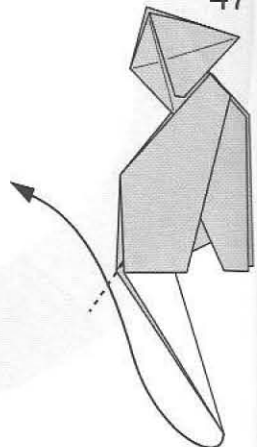

狼

Wolf

作／図 宮島 登

Models & Diagrams By Noboru MIYAJIMA

創作／2006年6月

作図／2008年6月

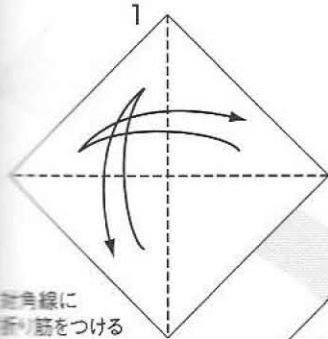
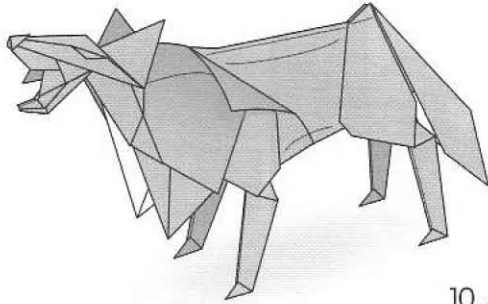

直角線に
折り筋をつける
(2箇所)

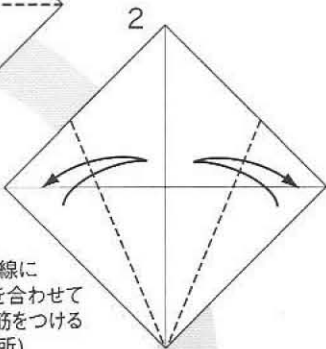

中心線に
フチを合わせて
折り筋をつける
(2箇所)

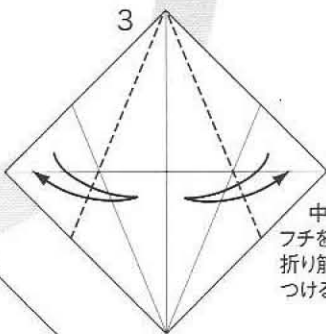

中心線に
フチを合わせて
折り筋を
つける(2箇所)

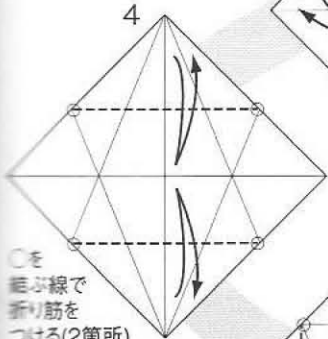

○を
結ぶ線で
折り筋を
つける(2箇所)

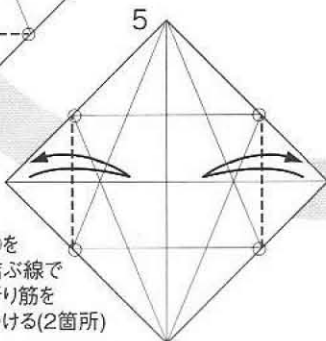

○を
結ぶ線で
折り筋を
つける(2箇所)

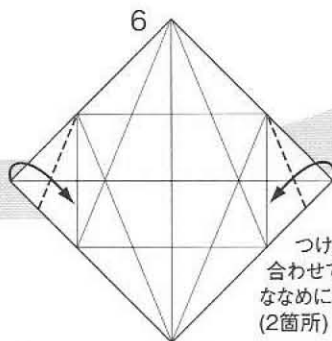

前の工程で
つけた折り筋に
合わせてフチを
ななめに折る
(2箇所)

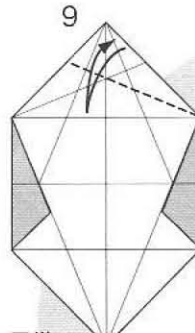

同様に
折り筋をつける

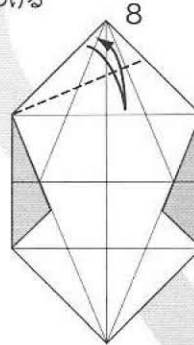

折り筋に
フチを合わせて
折り筋をつける

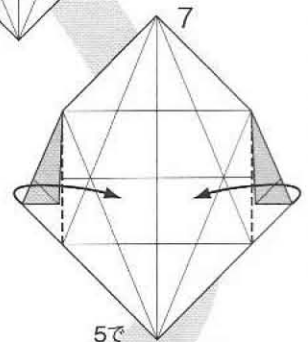

5で
つけた折り筋で
カドを折る(2箇所)

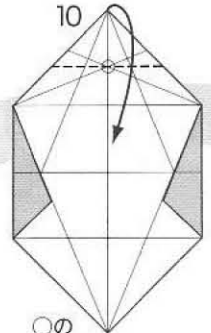

○の
交点を通る線で
カドを真下に折る

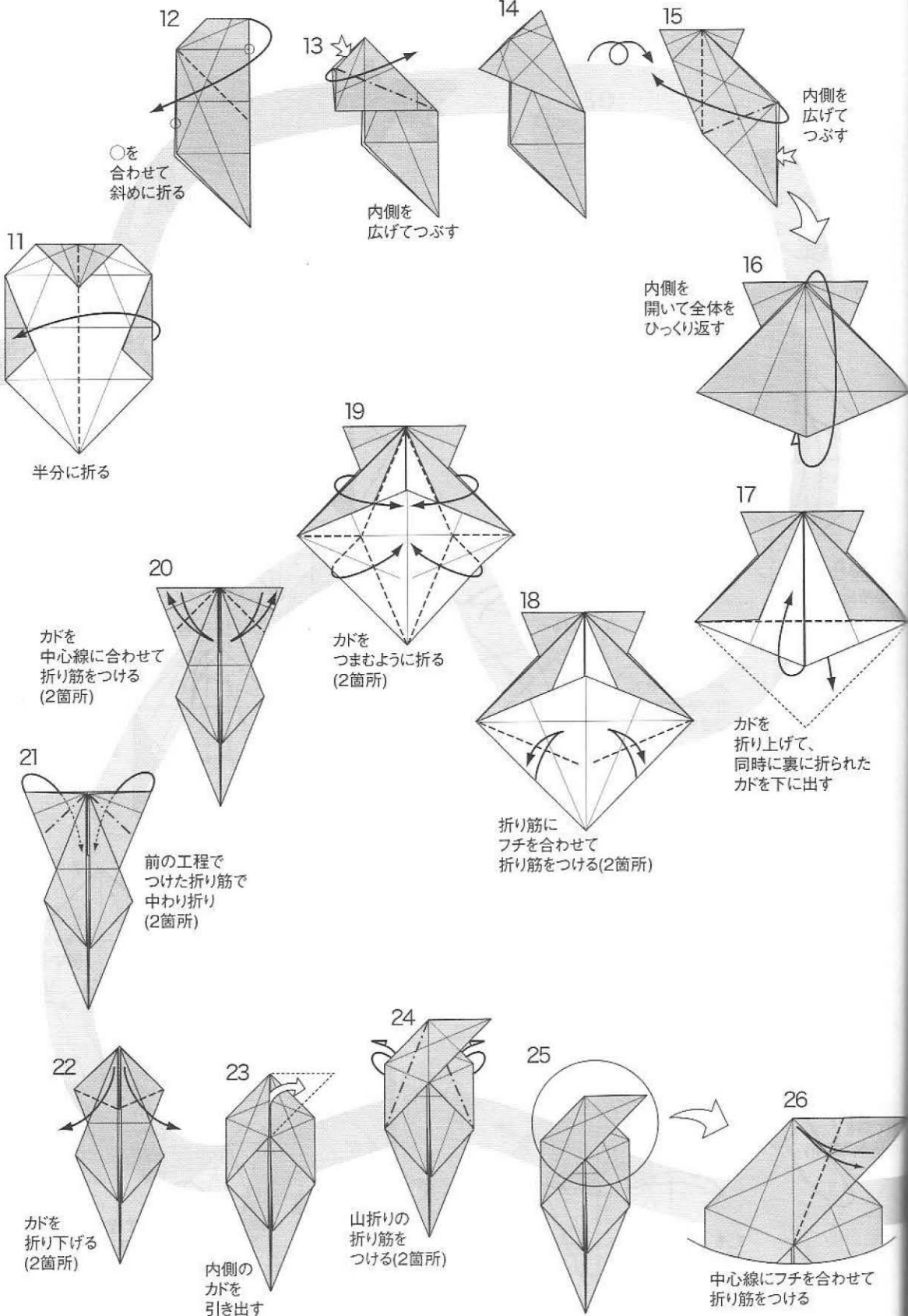

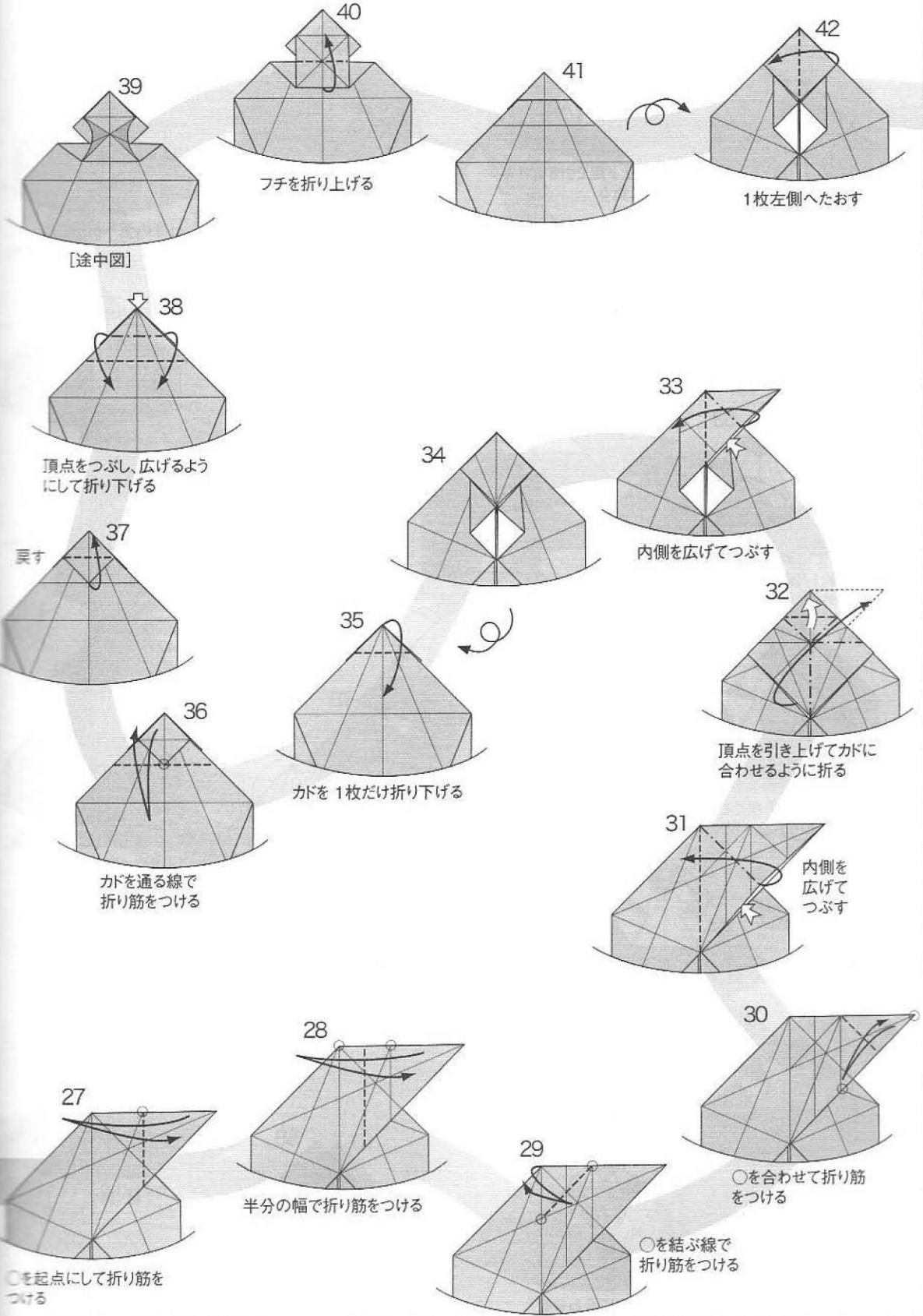

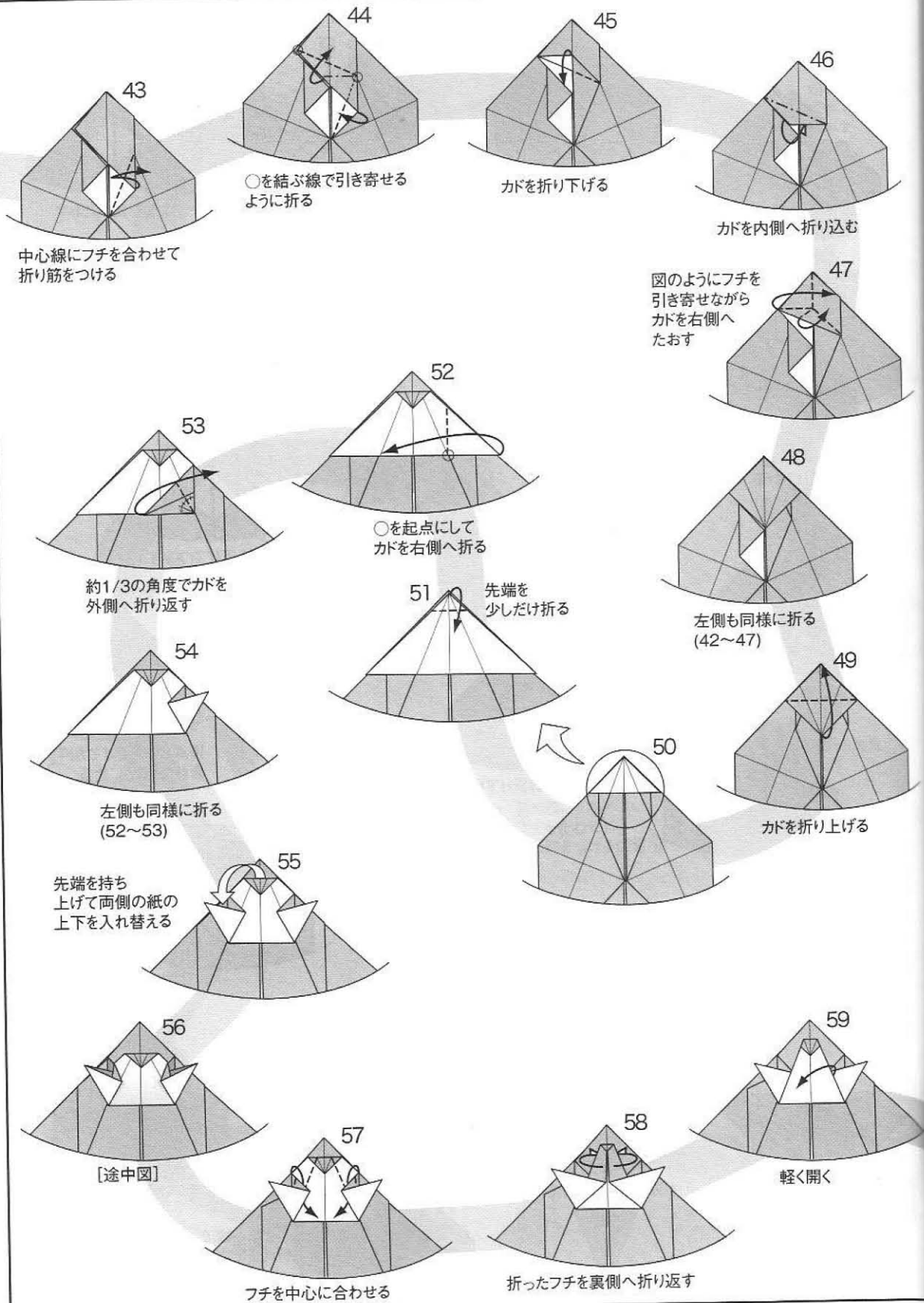

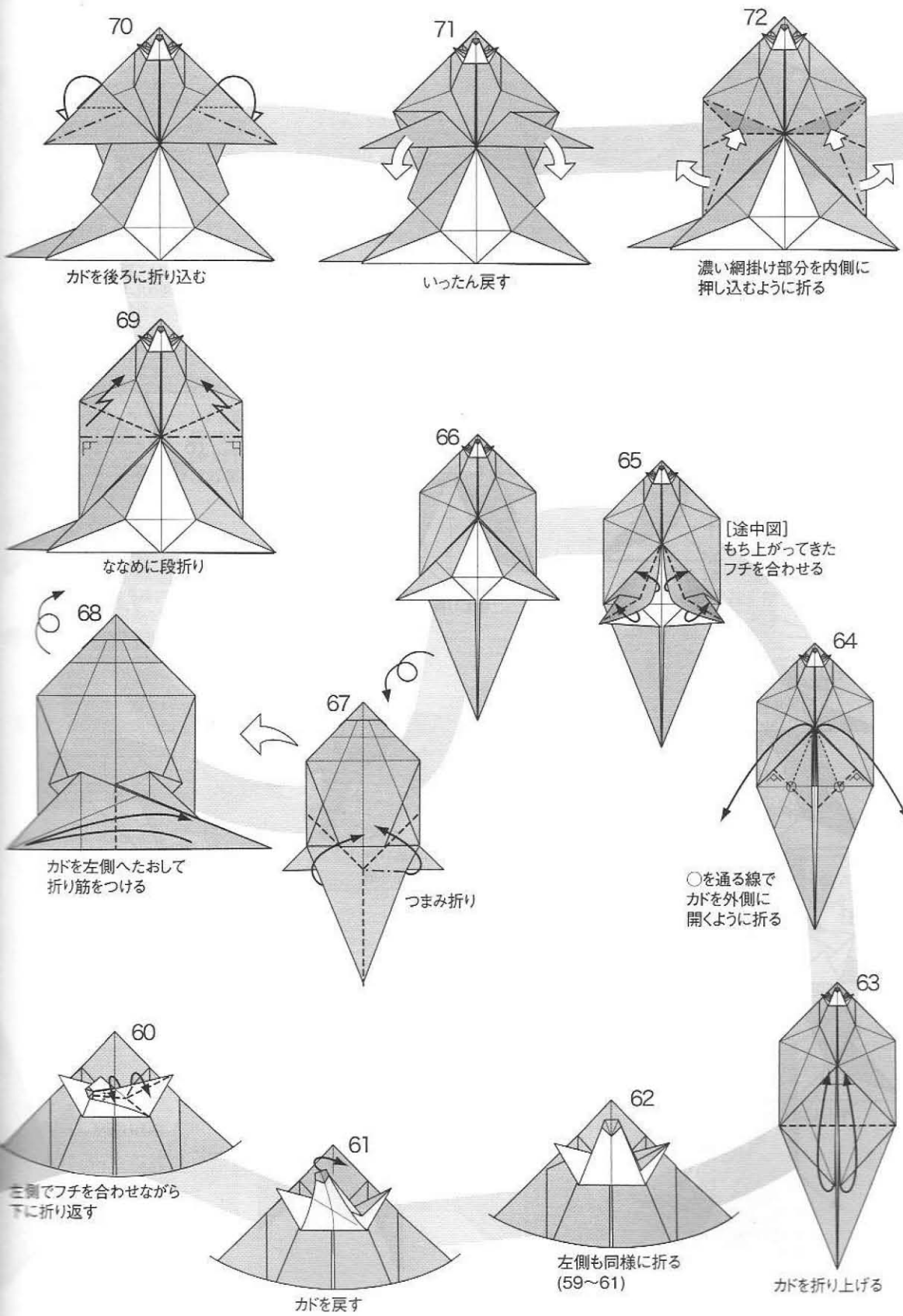

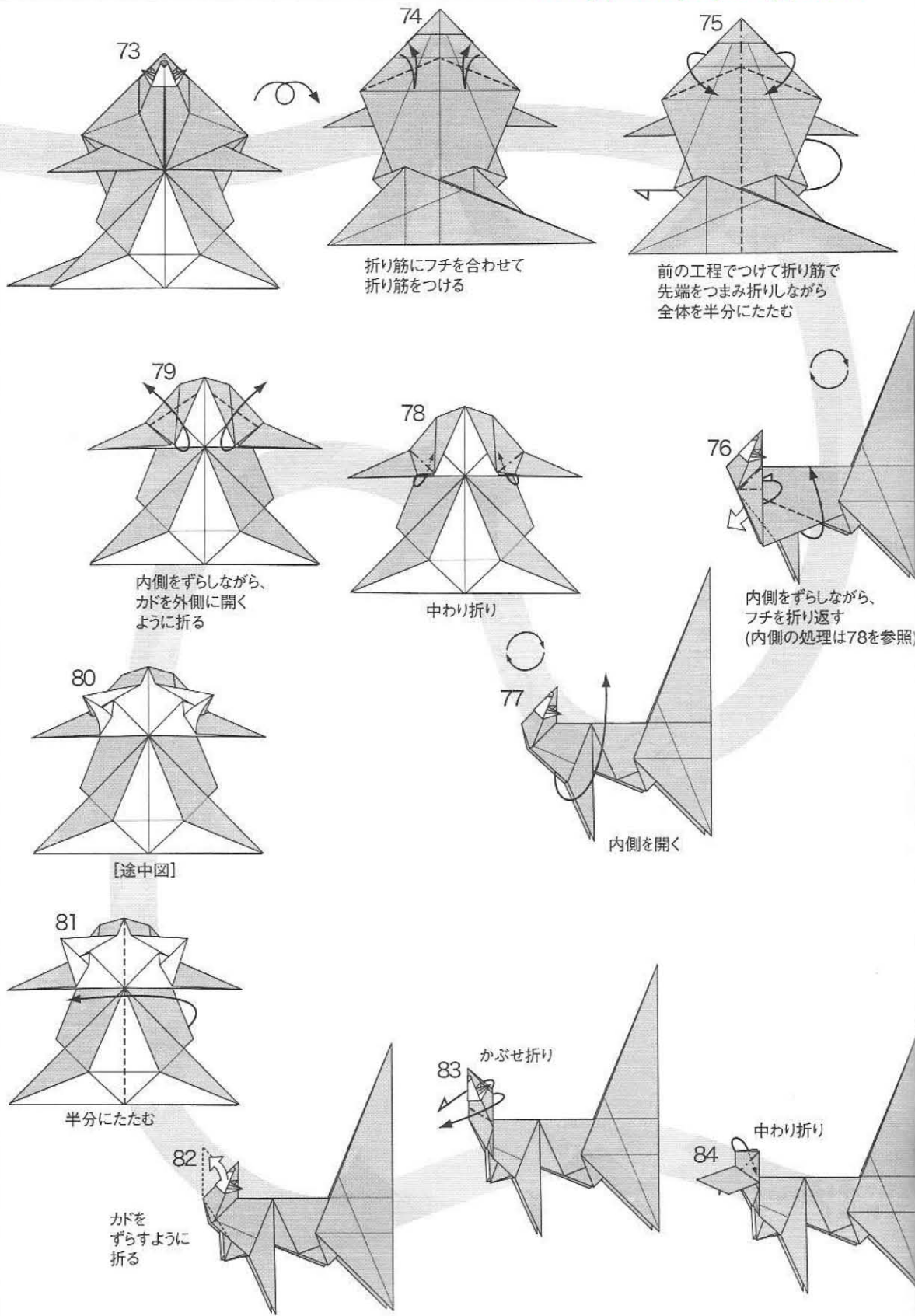

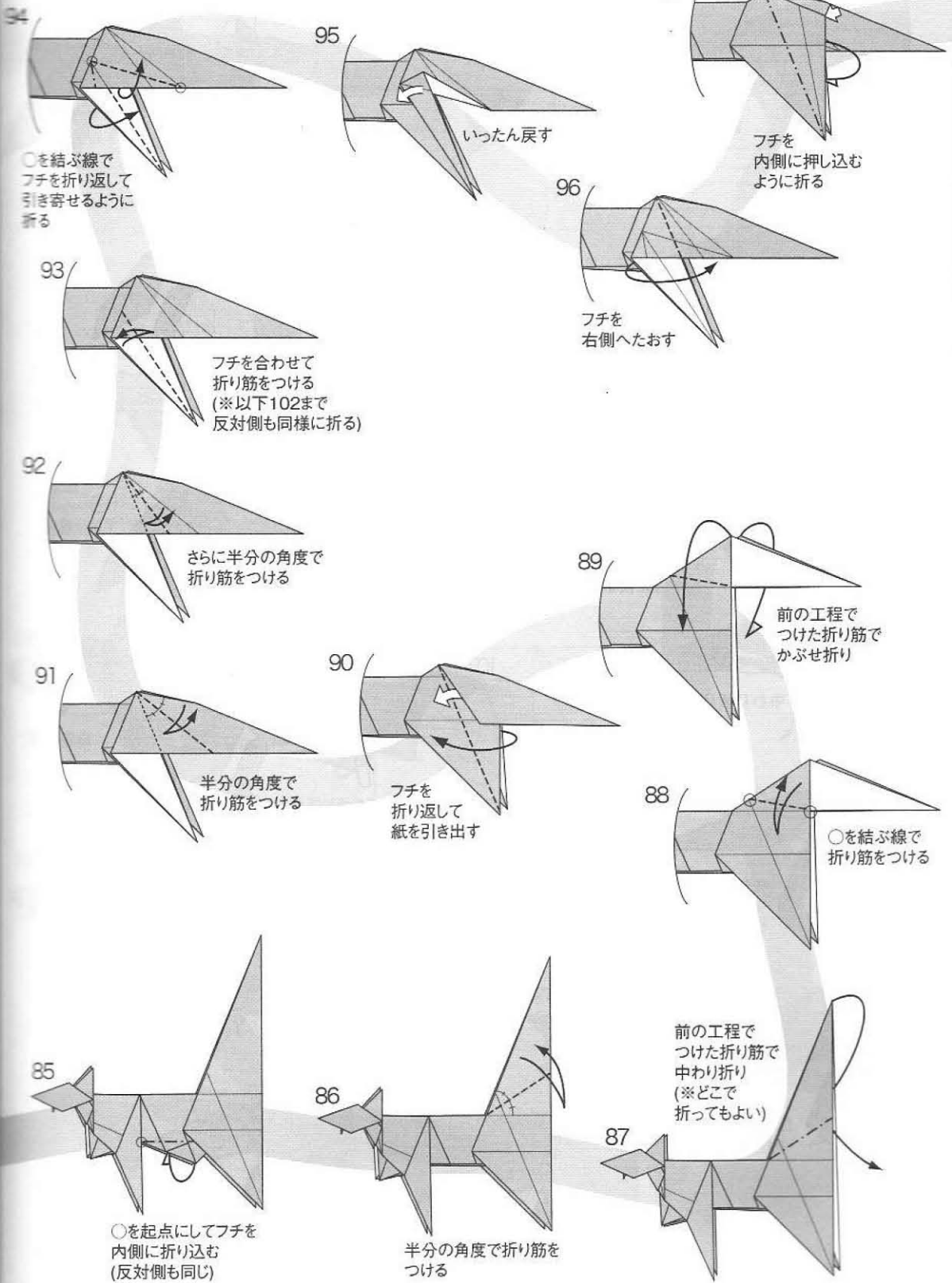

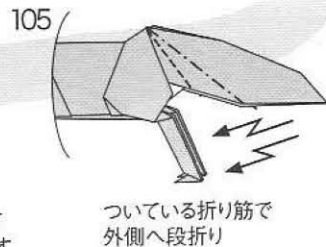
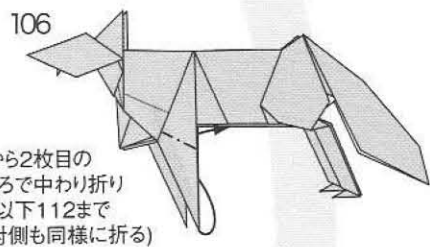
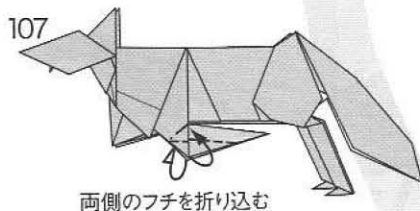
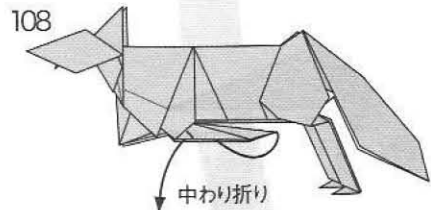
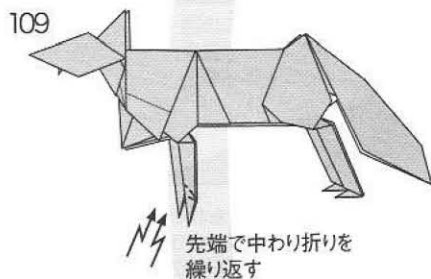
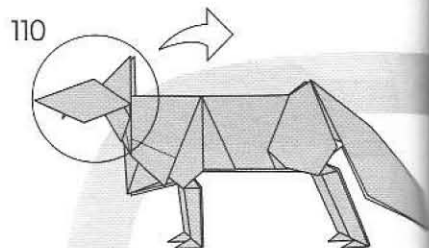
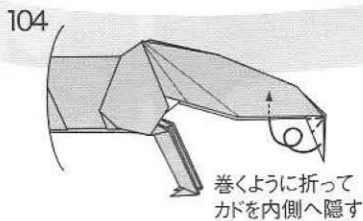
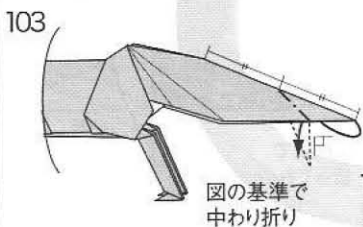
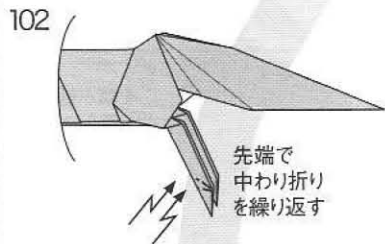
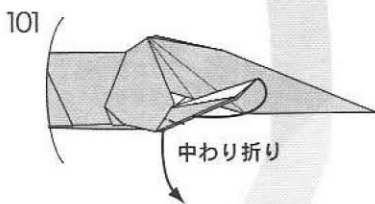
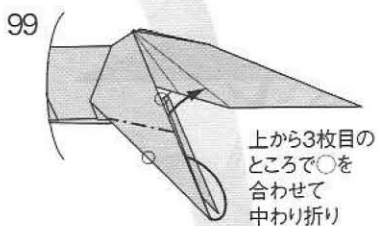
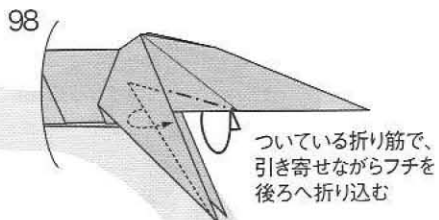

111

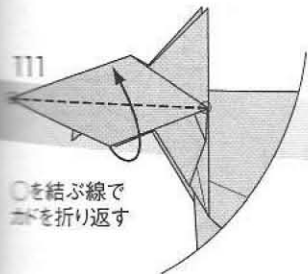

○を結ぶ線で
カドを折り返す

112

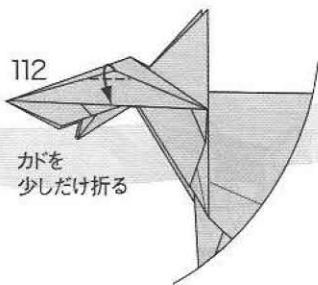

カドを
少しだけ折る

113

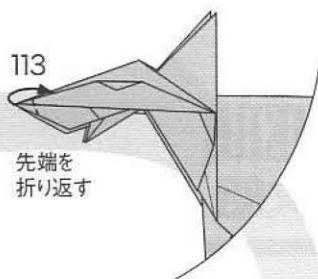

先端を
折り返す

117



先端で
中わり折りを
繰り返す

116

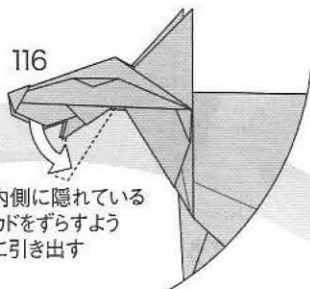

内側に隠れている
カドをずらすよう
に引き出す

114

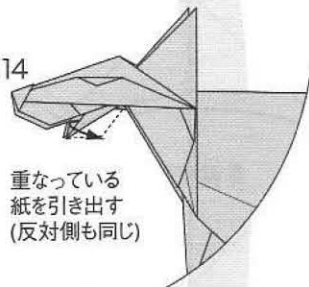

重なっている
紙を引き出す
(反対側も同じ)

115

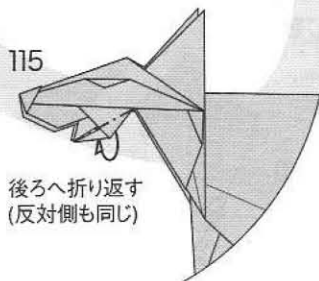

後ろへ折り返す
(反対側も同じ)

118

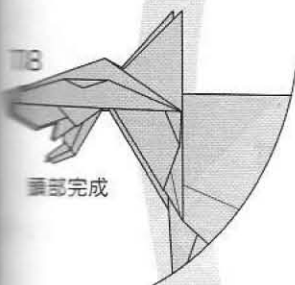

頭部完成

119

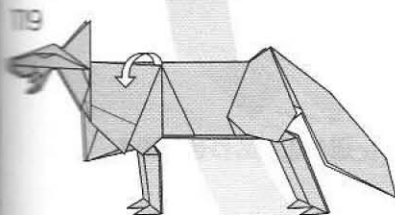

フチを巻いてカールさせる
(反対側も同じ)

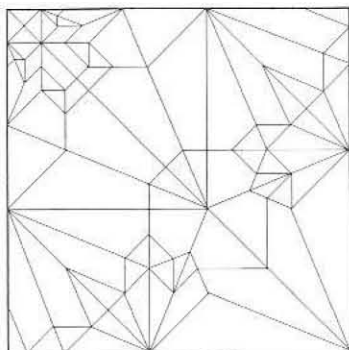

[展開図]

120

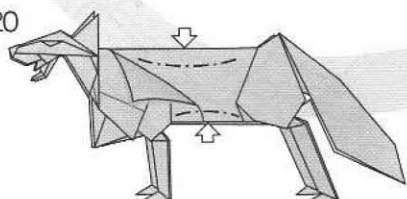

背中と腹を押し込み、
胴体に丸みをつける

121

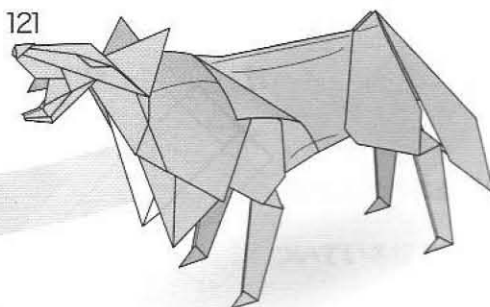

できあがり

猫君 CAT HERR 川畑文昭

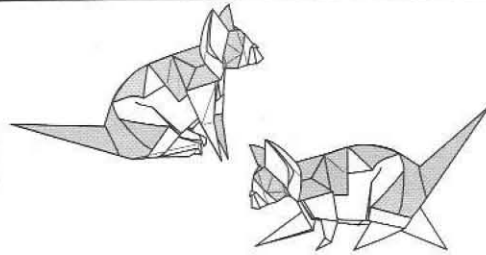

Fu
Ka  iaki
ahata

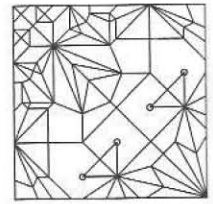

★★創作にあたって★★

私は前川淳さんの猫が好きで、本作はその技法を参考にしてます。またお尻の処理は田中将司さんと小松英夫さん合作のねずみの技法を参考にさせていただきました。感謝いたします。

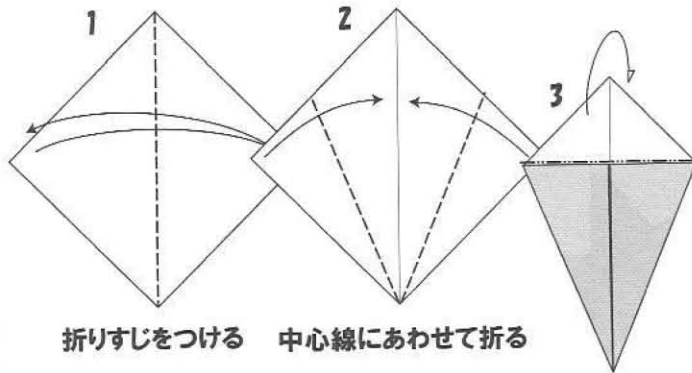

1 折りすじをつける 2 中心線にあわせて折る

3 向こう側に折る

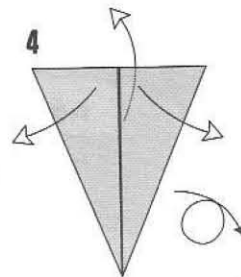

4 全部広げる

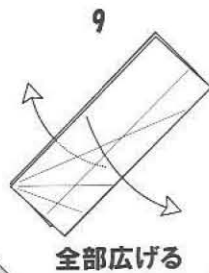
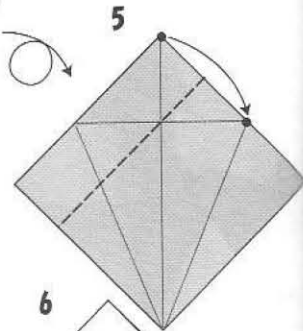

9 全部広げる

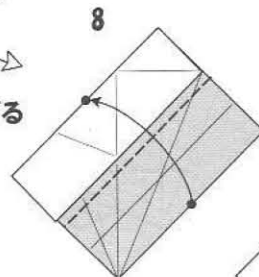

8 辺と辺をあわせて折る

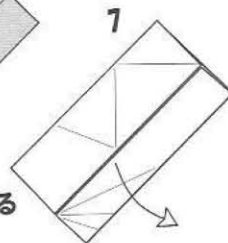

7 折ったところを広げる

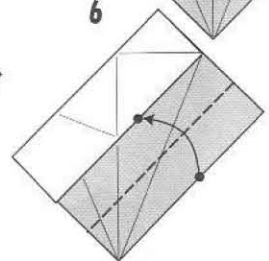

6 辺と辺をあわせて折る

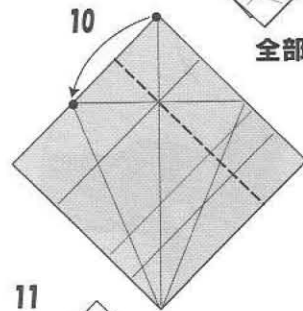

10

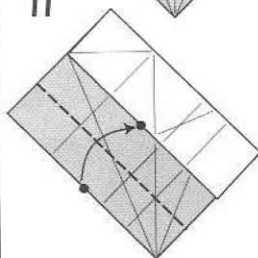

11 辺と辺をあわせて折る

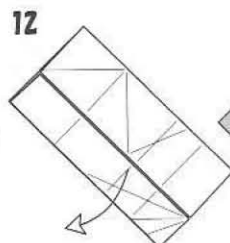

12 折ったところを広げる

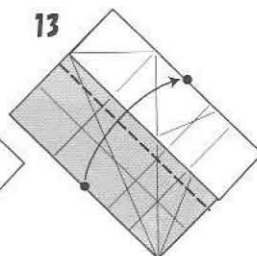

13 辺と辺をあわせて折る

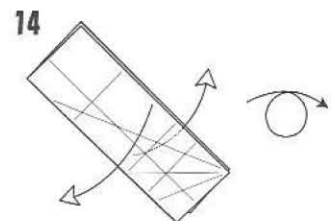

14 全部広げる

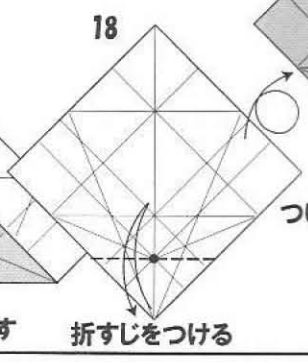
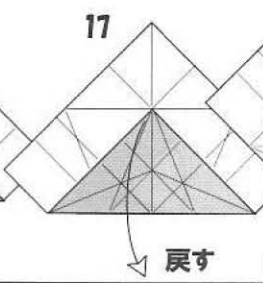
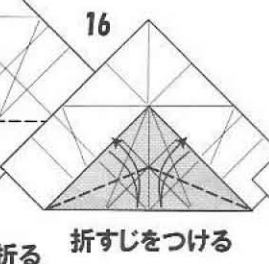
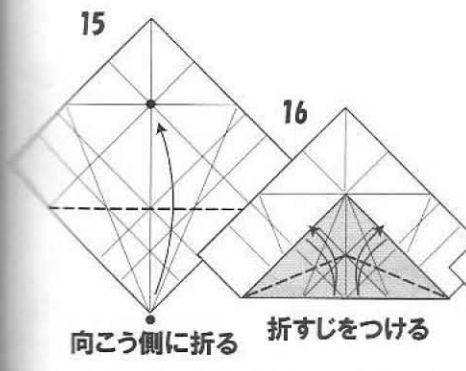
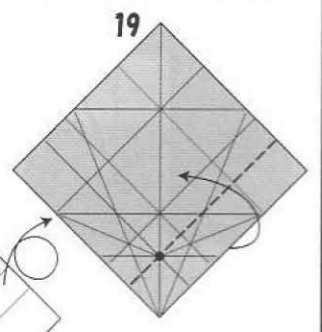
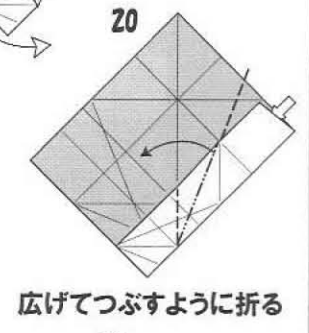
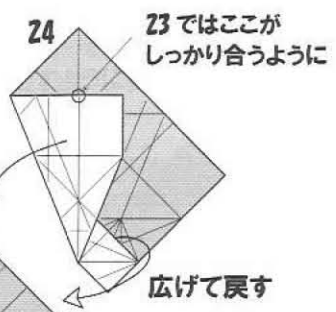
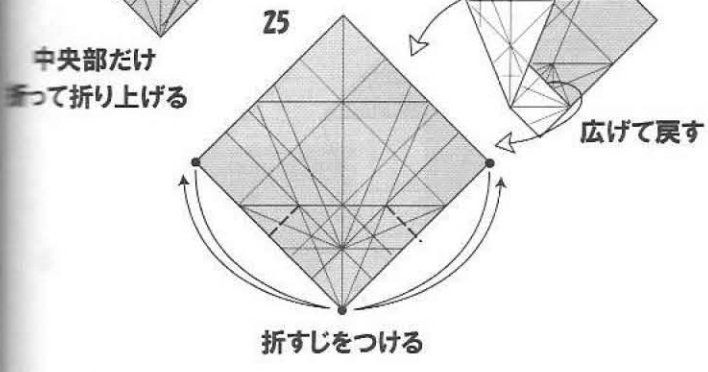
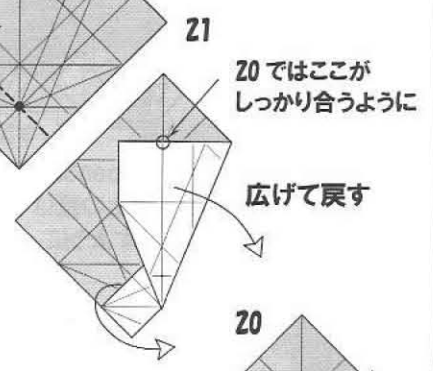
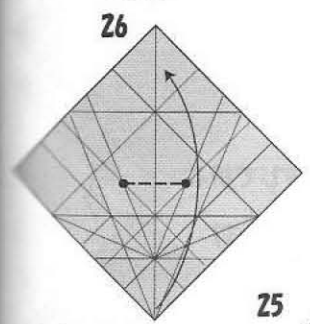
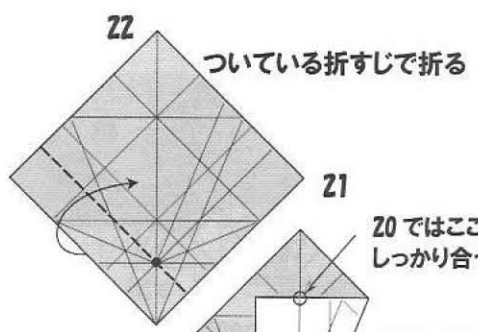
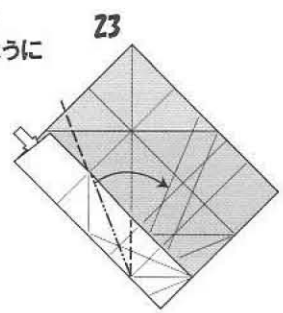
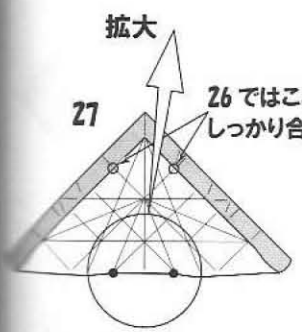
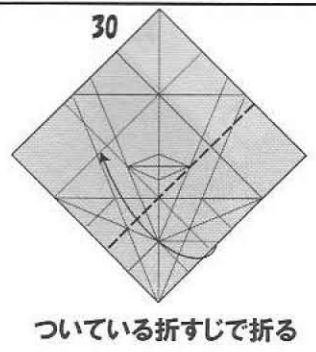
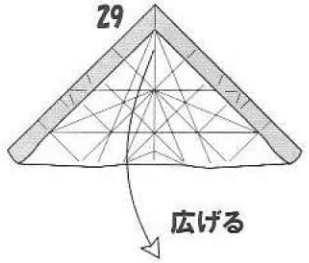
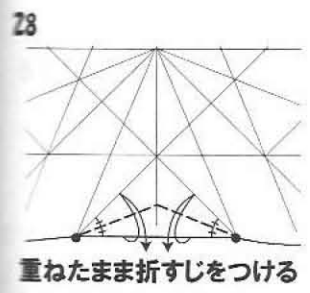

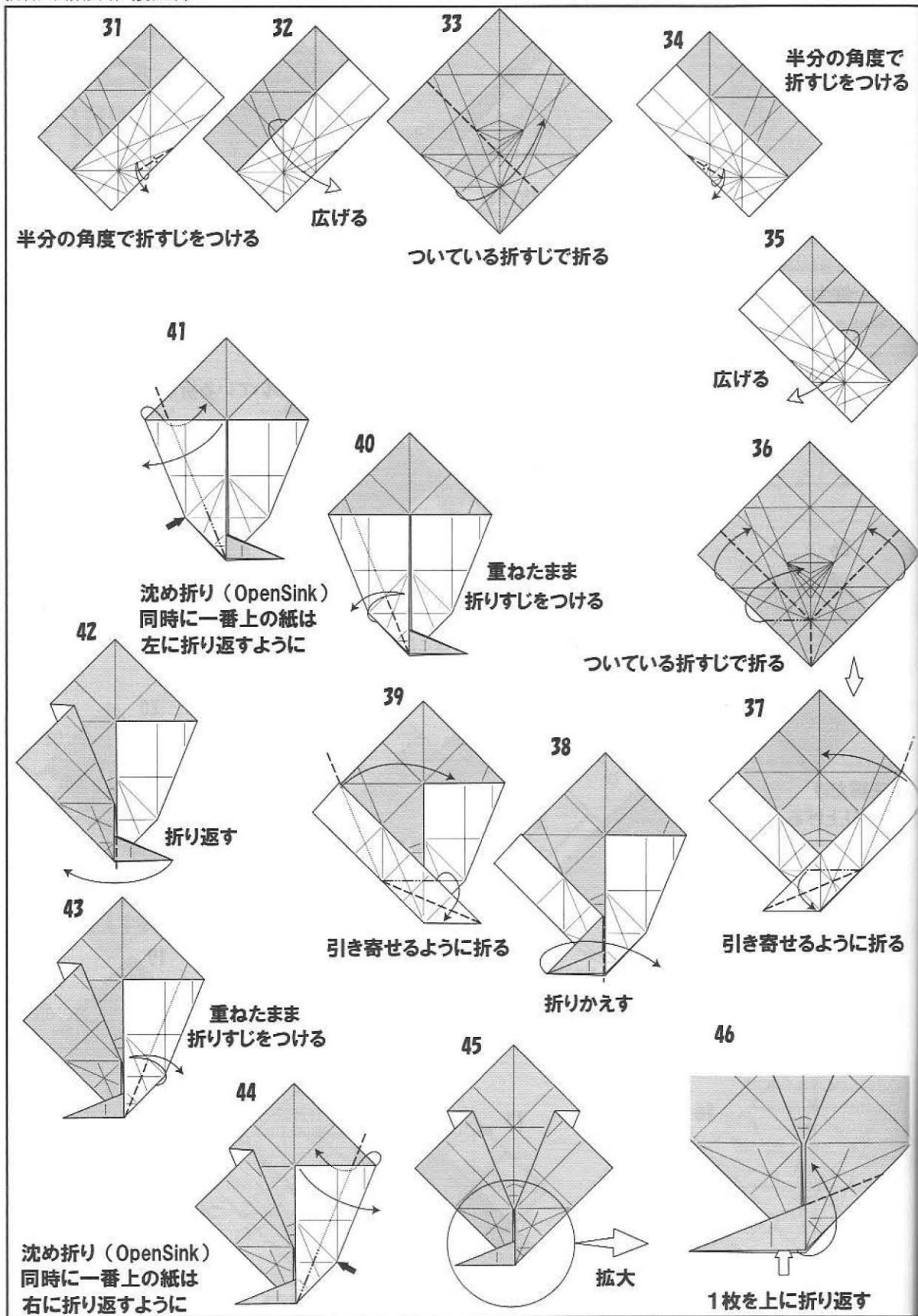

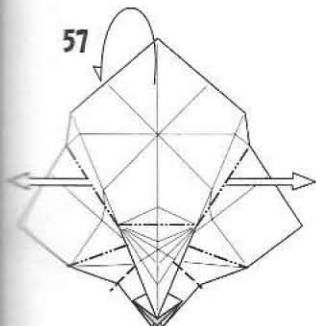

途中図
裏側から見た状態

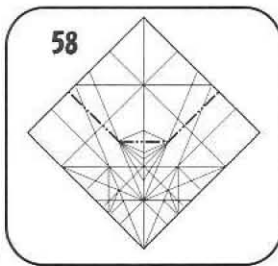

参考図
使う折すじの位置

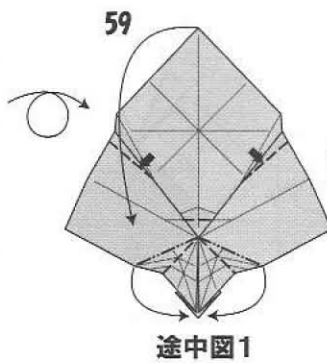

途中図1

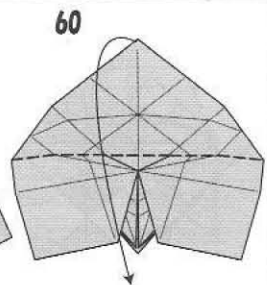

途中図2

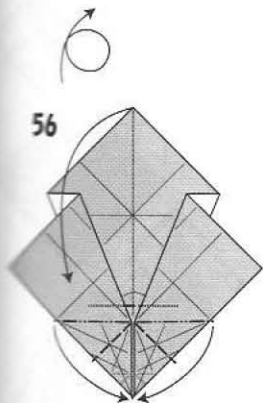

上のカドを手前に
引き起こすように
しながらまとめる

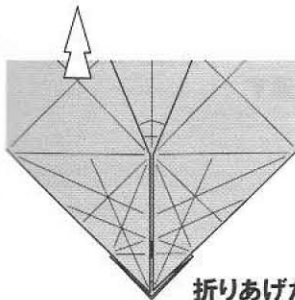

折りあげた形

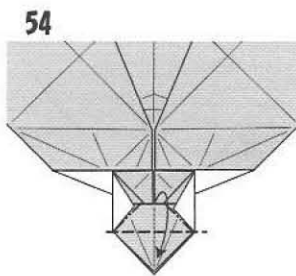

52 でつけた折すじを使って
上の1枚を下に
引き出すように折る

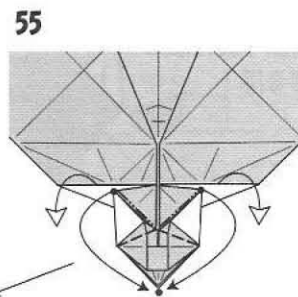

カドどうしをあわせるように折る

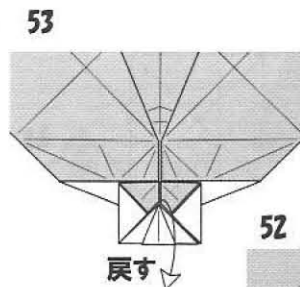

戻す

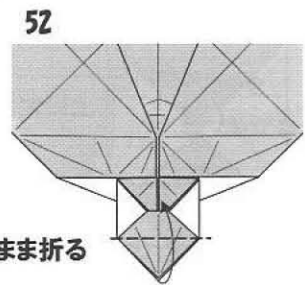

重ねたまま折る

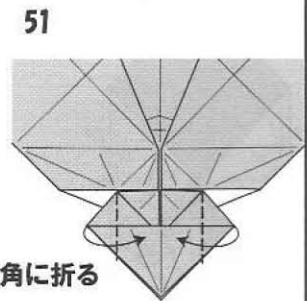

三角に折る

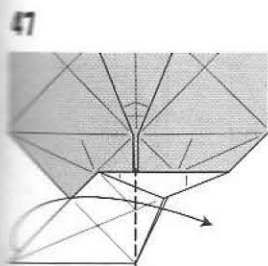

折り返す

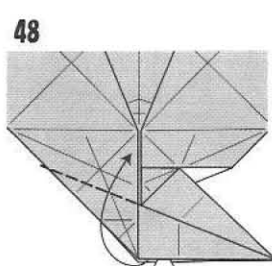

1枚を上折り返す

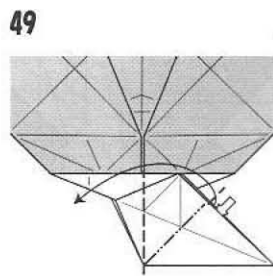

広げてつぶす

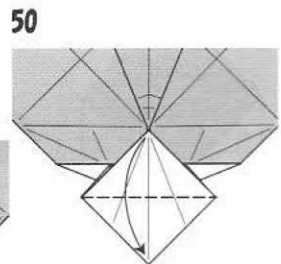

1枚を下に折り返す

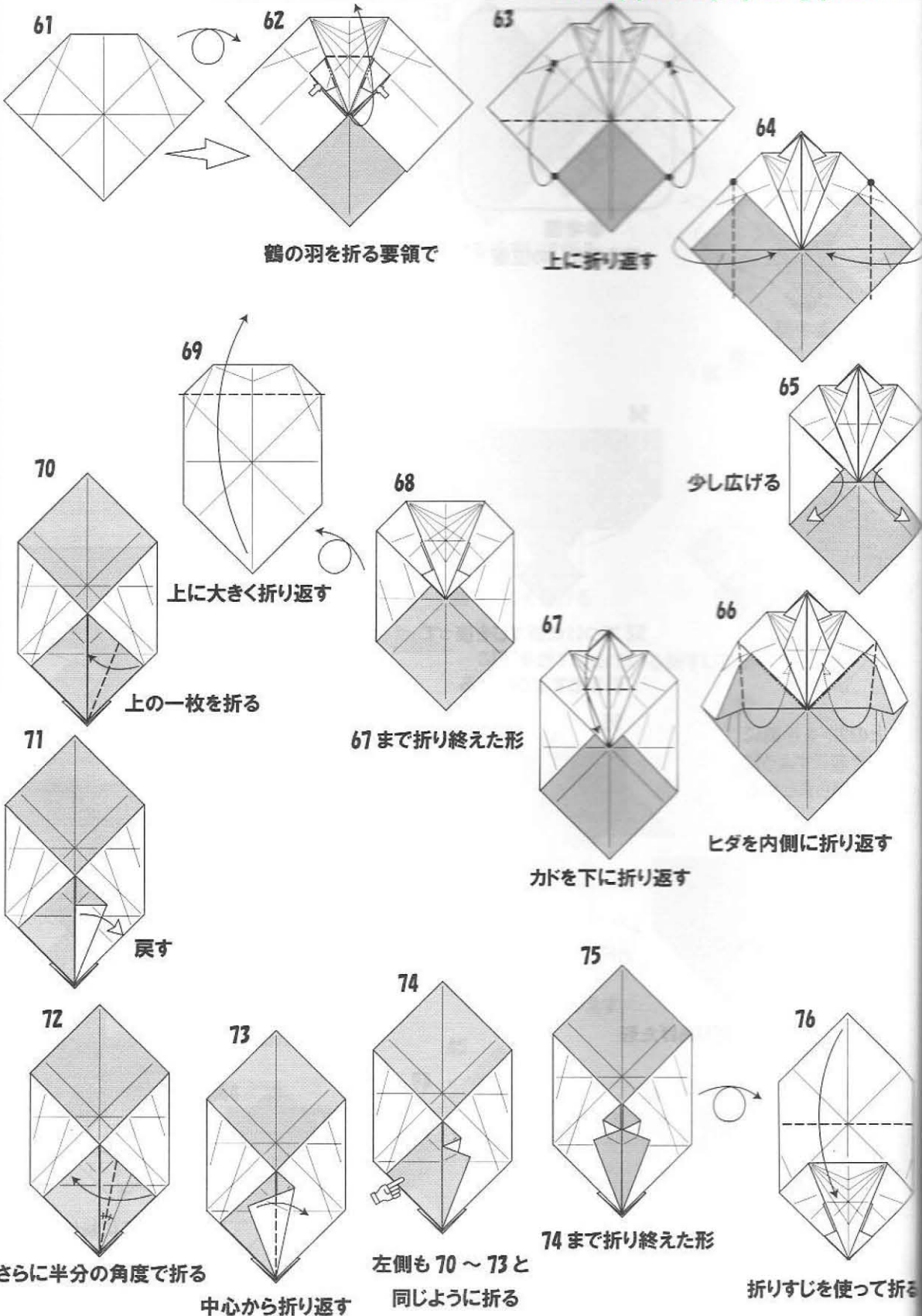

連続的な折り

耳の部分を折り返しながら
同時に中央の紙を
左右に折り返す

88

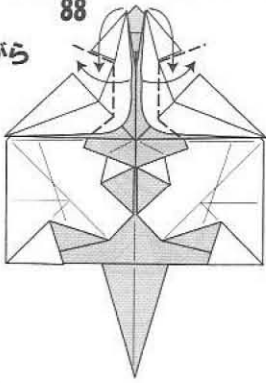

89

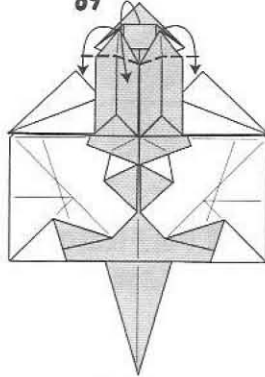

90

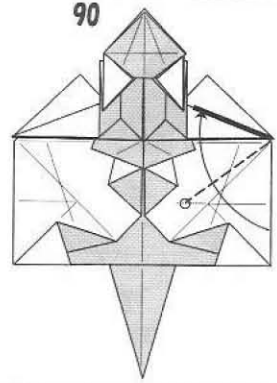

カドをあわせて折る

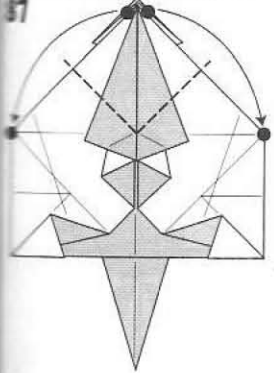

途中図

辺をあわせるように折る

83

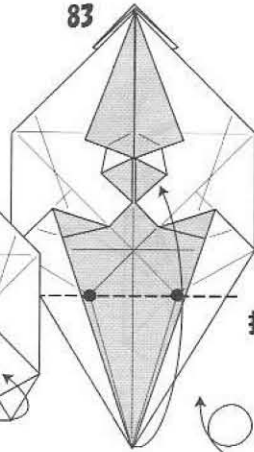

カドを
折りあげる

84

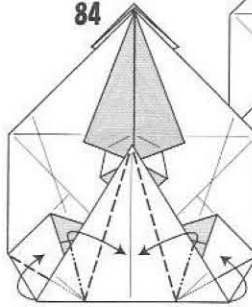

ついている
折すじをつかって
引き寄せるように折る

86

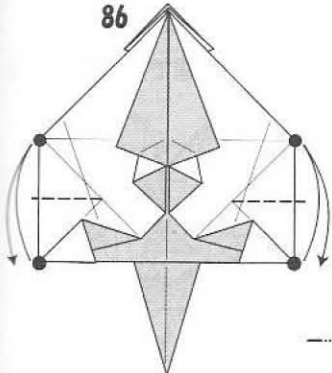

折すじをつける

85

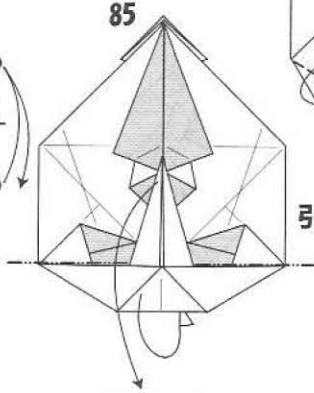

折りかえる

82

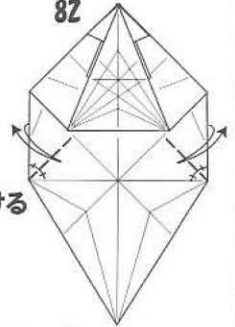

折りすじをつける

77

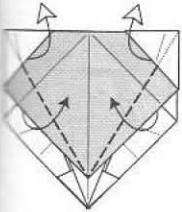

袋の部分を上
引っ張るように

78

ここは折らない

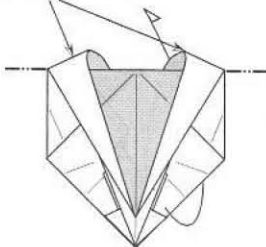

向こう側の
カドを折り返す

79

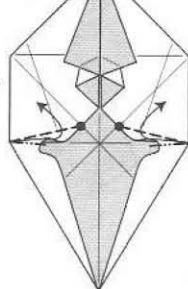

折って平らにつぶす

80

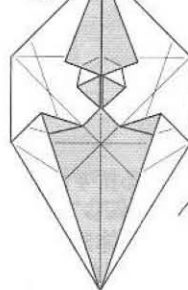

79まで折り終えた形

81

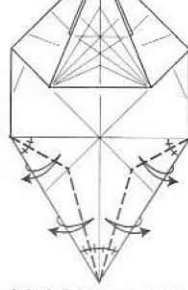

折りすじをつける

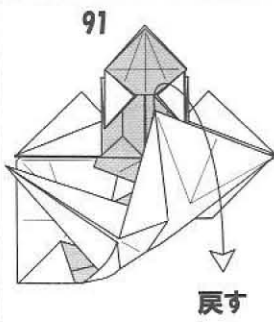

戻す

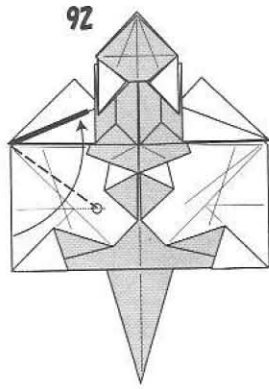

辺をあわせるように折る

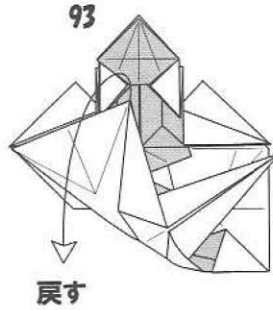

戻す

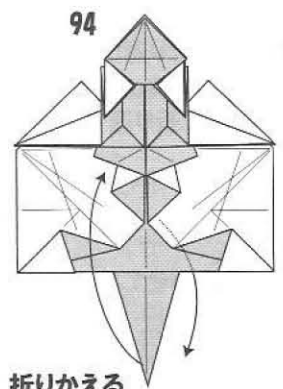

折りかえる

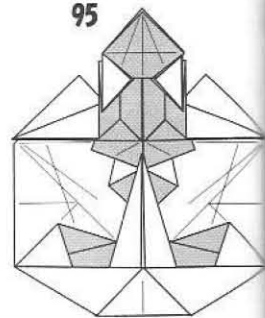

94まで折り終えた形

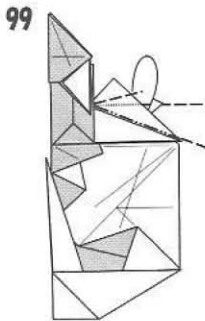

変則的中わり折り
向こう側も同じ

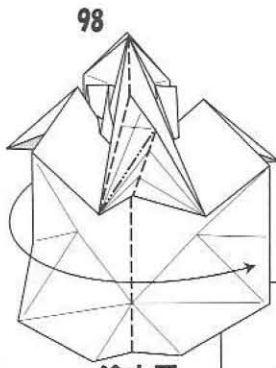

途中図

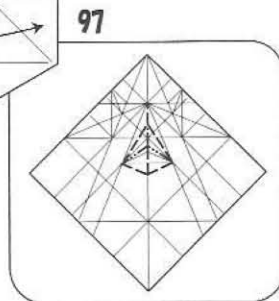

参考図
96で引き出すために
使う折すじ

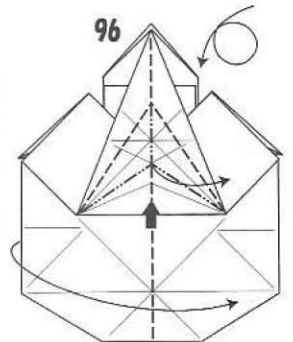

中央の部分の1枚を
ついている折すじに
そって手前に引き出しながら
全体を半分に折る

100

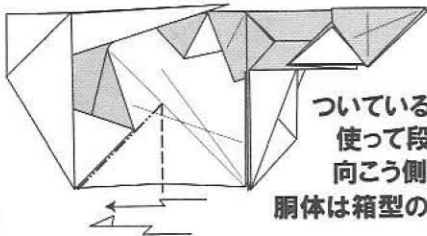

ついている折すじを
使って段に折る
向こう側も同時
胴体は箱型の立体になる

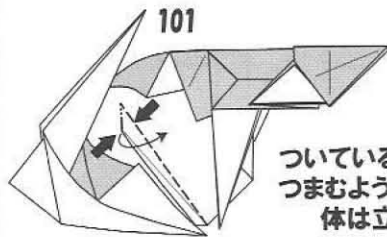

ついている折すじを使って
つまむようにして足を造形
体は立体的になる
向こう側も同時に
この時最も内側にある
紙は巻き込まないように

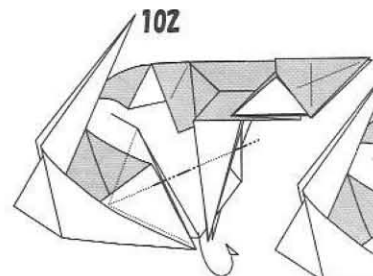

内側中央部に折り込む
向こう側も同じ

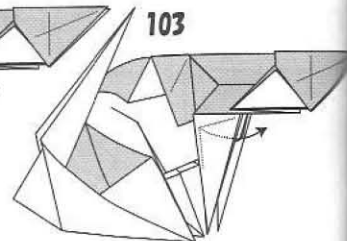

1枚引き出す
向こう側も同じ

114

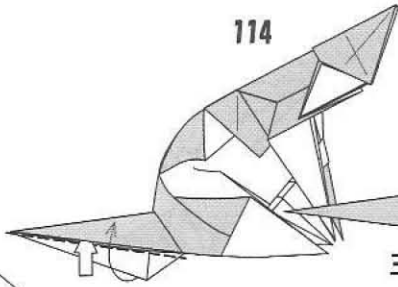

三角の部分を折り上げる
向こう側も同じ

115

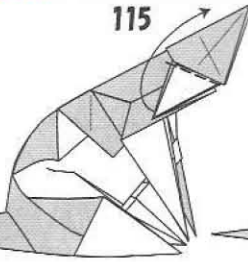

116

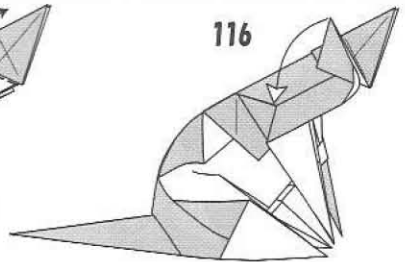

戻す
向こう側も同じ

113

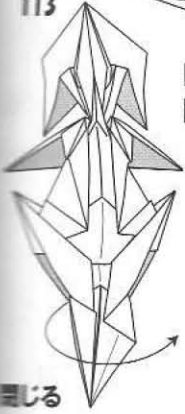

隙間に差し込んで尾を
開かないように止める

回じる

109

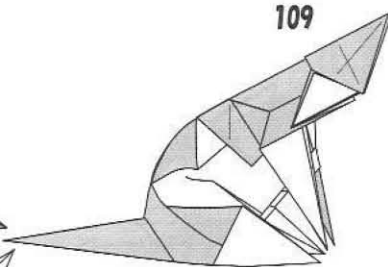

110

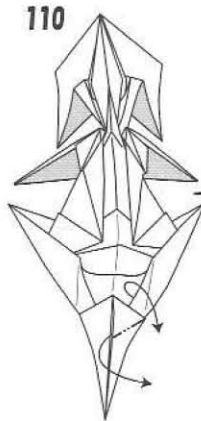

上の1枚を引き出す

↑
次のステップは
下から見る

108

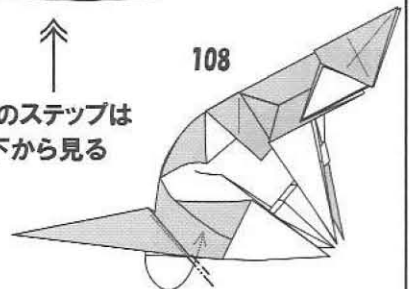

中わり折り

112

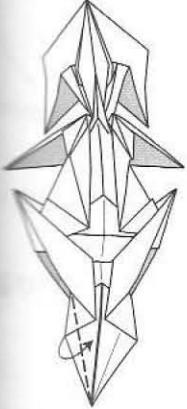

左側だけ
内側に折り込む

111

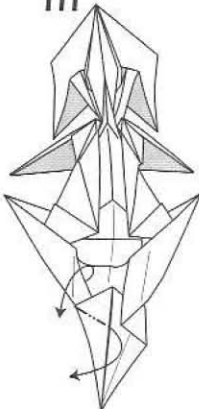

左側も同じ

107

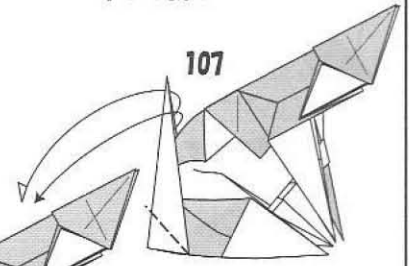

かぶせ折り

105

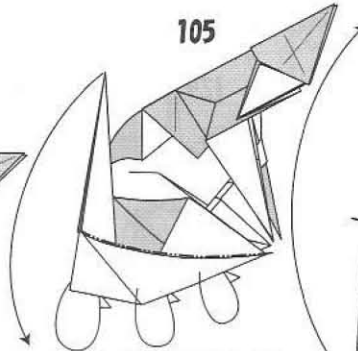

内側に折り込みながら
同時に尾を下に折り返す

106

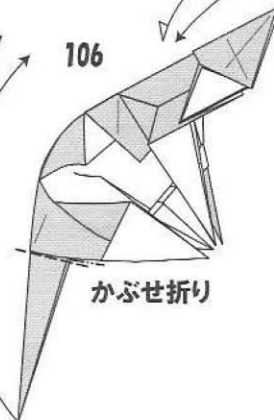

かぶせ折り

104

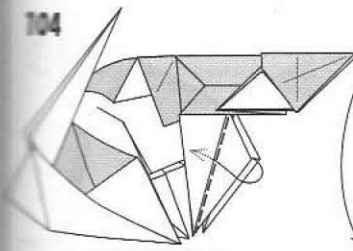

内側に折り込む
向こう側も同じ

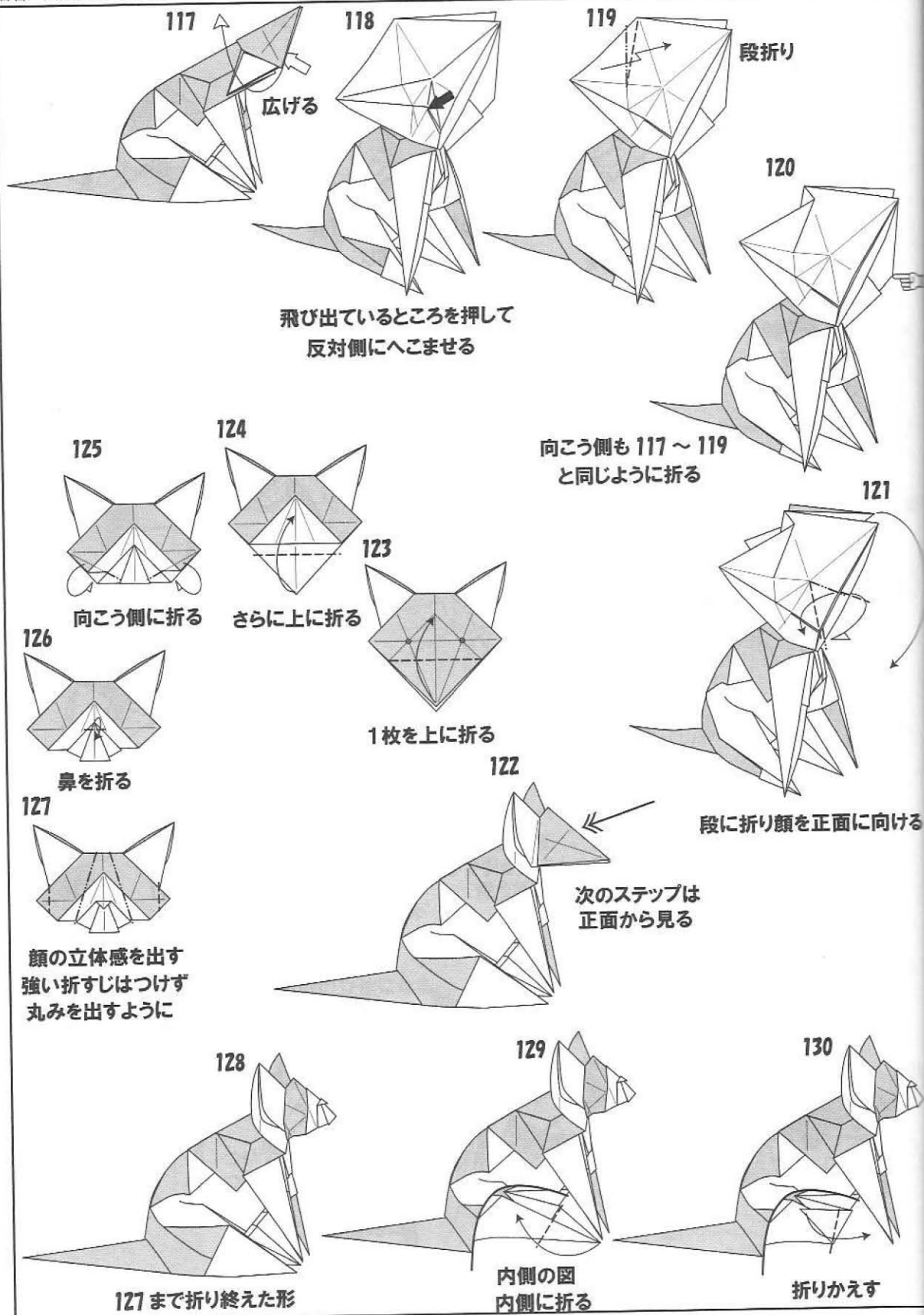

138

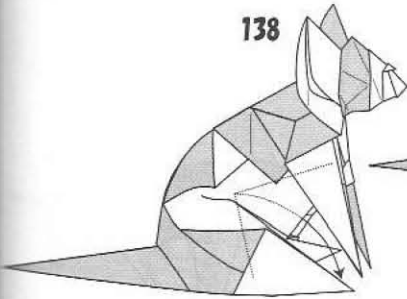

折りこんであるヒダを戻す (こちら側のみ)

139

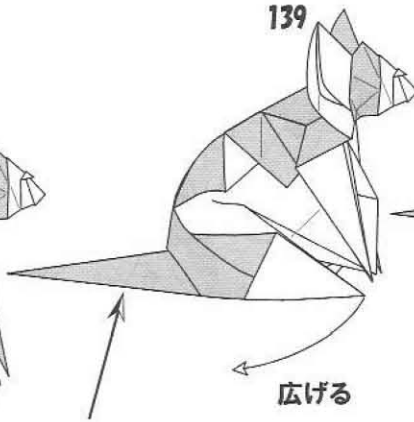

広げる

尻尾の止めが外れたときは最後にまた止め直してください

140

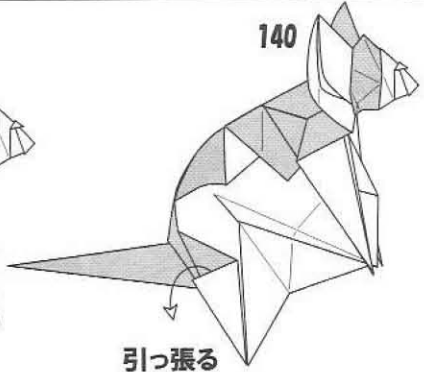

引っ張る

135

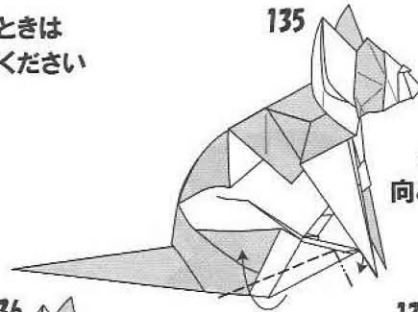

足を折る
向こう側も同じ

137

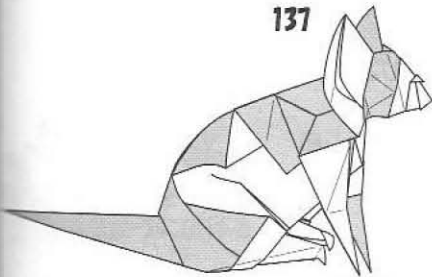

座っている姿のできあがり

136

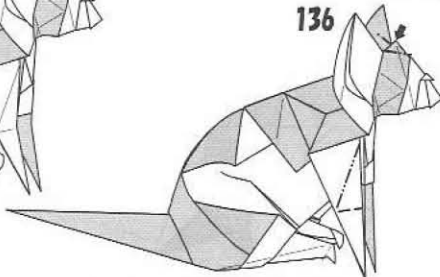

おでこの部分を押し込む
前足の形を整える

134

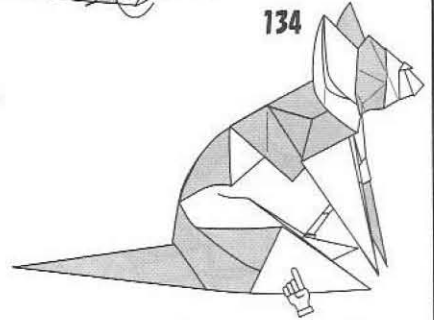

手前側も 129 ~ 132
と同じように折る

131

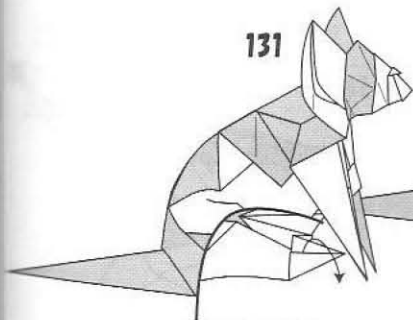

一枚を引き出す

132

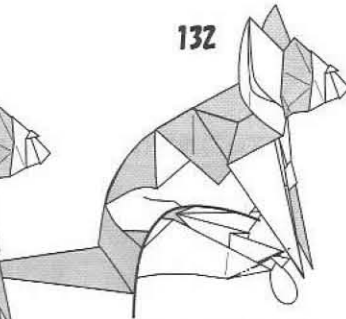

隙間に折こむ

133

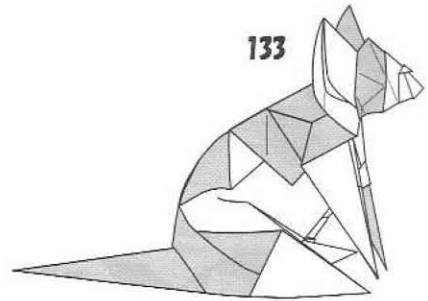

この後、座っている
姿にしたいときは 134 へ

そそくさと立ち去る
姿にしたいときは 138 へ

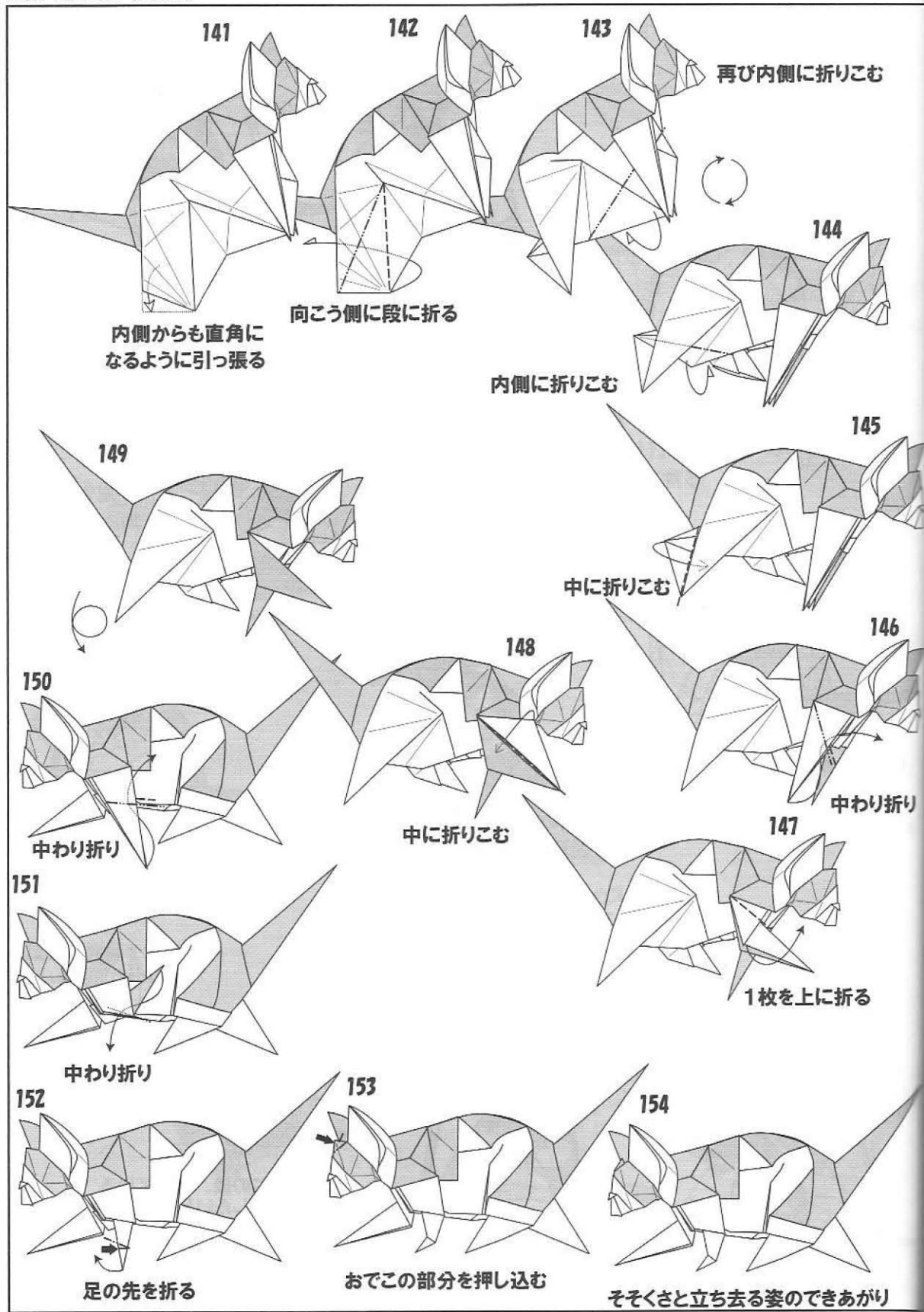

耳の折り方の別バージョンメモ

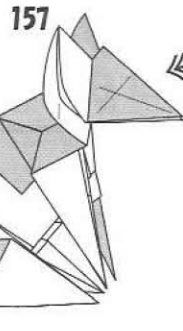
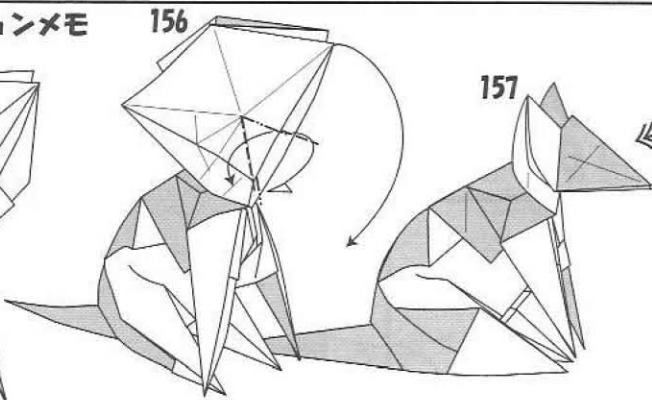

次のステップは
正面から見る

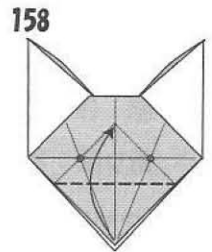

1枚を上折る

飛び出ているところを押して
反対側へこませる
向こう側も同じ

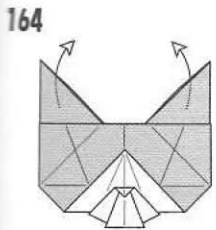

向こう側の1枚を手前側に
折り返すように広げる

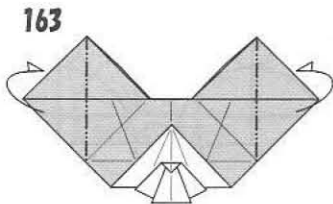

向こう側に折り込む

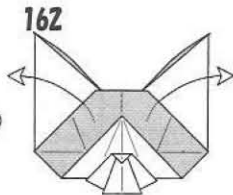

内側から引き出す

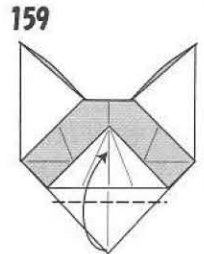

さらに上に折る

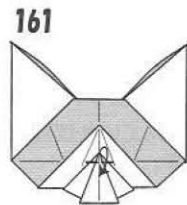

鼻を折る

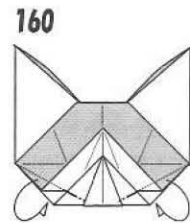

向こう側に折る

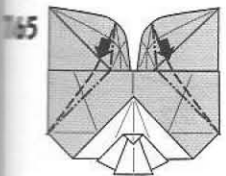

押し込むように段折り

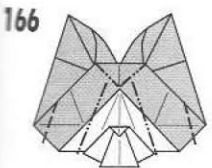

この折方のメリットは
腫が浮き上がらないように
止めが可能なことです

創作メモ 70～74の折り方を変えると、いろいろな模様が折りだせます。
茶色と黒の紙を2枚重ねて、三毛猫を折ることもできます。
足の折り方はほんの一例ですので、色々な姿を考えましょう。
127のあと耳はさらに段に折って表情を変えても面白い。

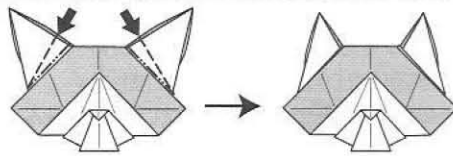

いずれにしても、好きな形にして楽しめればよいのです。

167 後は同じ

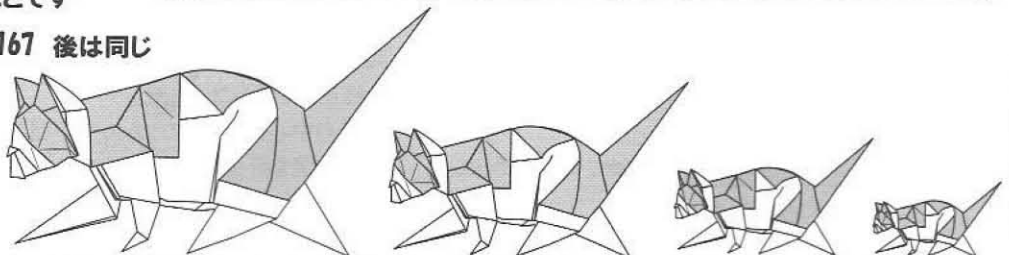

アゲハチョウ Swallowtail Butterfly

創作: 目黒俊幸

折り図: おりがみはうす

Design: Meguro Toshiyuki

Diagrams: Origamihouse

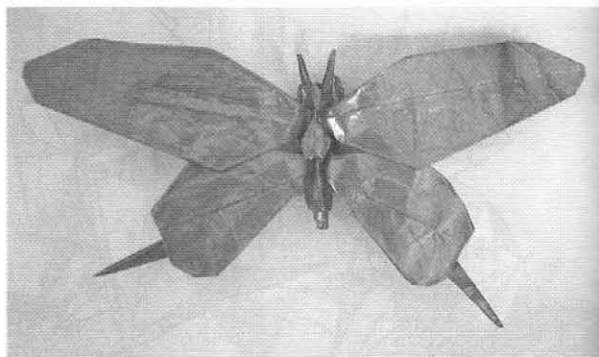

【アゲハチョウ】

この作品は初めザリガニを折るために設計した基本形を蝶に見たて換えて出来たものです。設計方法は円領域分子法で設計に要した技法は特に難しいものではなく標準的なものです。折り図はおりがみはうすが精密なものを描いてくれたのですが、この種の折紙設計に慣れていない人がこの折り図を見たらどういう考えに基づいて折りが進んでいるのか全く理解できないと思います。

でもこの作品を創作した時、私は極めて単純な方針のもとに適当に紙を折っていただけでした。残念なことにその簡単さは、はうすの折り図がいくら詳しいとしても簡単に折り図から理解する事はできません。でもこのことは設計図をじっと見ていれば誰にでも解ることなのです。

ザリガニを作るにあたってまず考えたことは二本の触角と二本のはさみになる大きなカドが4つと胴体や足となる小さいカドがたくさんあればよいということです。ザリガニはそういう形をしていますから、これは当たり前前のことですよ。

そうすると設計にあたって紙の四隅に大きなカドがあつて、そのあまった部分に小さなカドが配置していると折りやすいと思います。これは折紙を知っている人だったら当然の考えで、カドを円で表すと図1のような配置だったら何となくうまくいくな気がしました。

それで今まで知られている性質のよい分子を組み合わせてこのような円領域構造が出来ないか考えてみました。

図2は第一たこ形分子団という、折紙設計では有名な分子団とその円領域ですが、これを8個組み合わせ正方形にすると上記の目的にかなうことに気付きました(図3)。

これでザリガニはできた訳ですが、これを折ってい



図1



図2

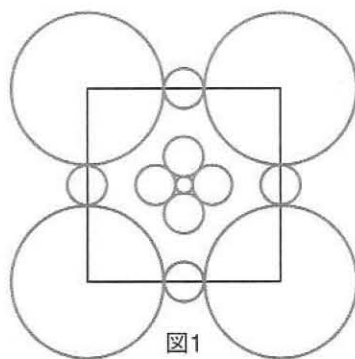

図3

ると中で、はさみと触角に用いる4つの角を羽にすれば蝶になると思いつきました。そのために図3の展開図を修正して図4にしました。

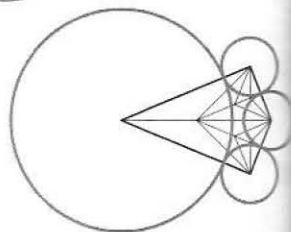
用紙の中心部は4つのツルの分子団で埋めました。後は設計図を折っていけばよいのです。

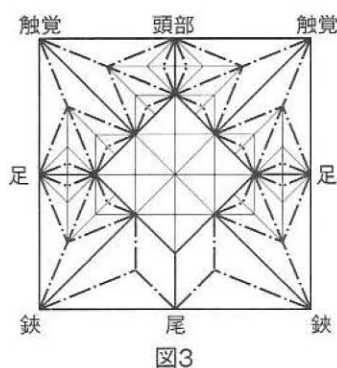

図4 アゲハチョウの展開図

では図3や図4の設計図をどういう折り順で折ればよいのでしょうか。答えは「適当に折る」です。図3や図4は円領域と分子の関係から、必ず実際に折りたたみ可能です。だから適当に折っていれば何となく折れてしまっただけで折り上がりの形は大きなカドを4つと多くの小さなカドを持つようになっているのです。これは絶対にそうなる様になっているので安心して適当に折っていればよいのです。もし折り方が解らなくなったら、第一この形分子団1個だけを実際に折ってみて（これは簡単です）それを続けたものとして頭の中で想像すると解りやすくなります。とはいっても慣れない内は大変ですが、折紙設計でできた作品を理解して折る方法はこれしかありませんので、試してみてください。

(1999年 目黒俊幸)

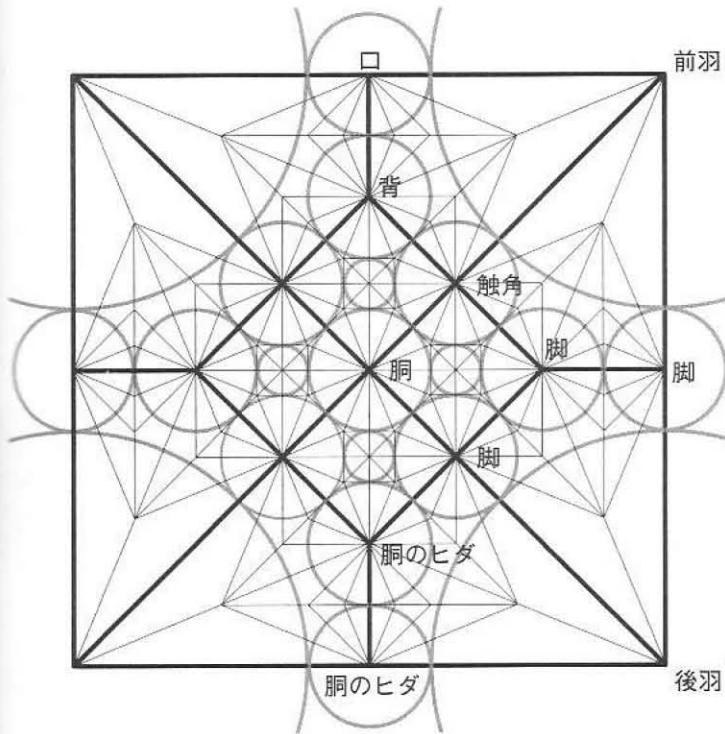
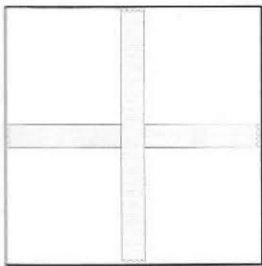

図のようにセロハンテープで中心部を補強しておくとうい

[つるの基本形]から始める

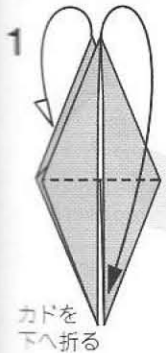

カドを下へ折る

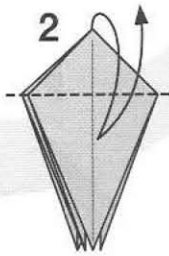

カドのところで折り筋をつける

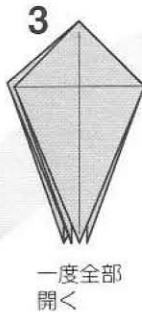

一度全部開く

4 折り筋を図のようにつけ直して折りたたむ(風船の基本形)

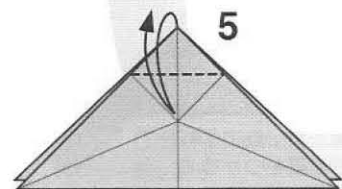
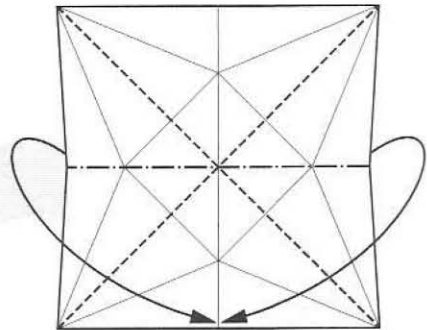

カドを折り筋の交点に合わせて折り筋をつける

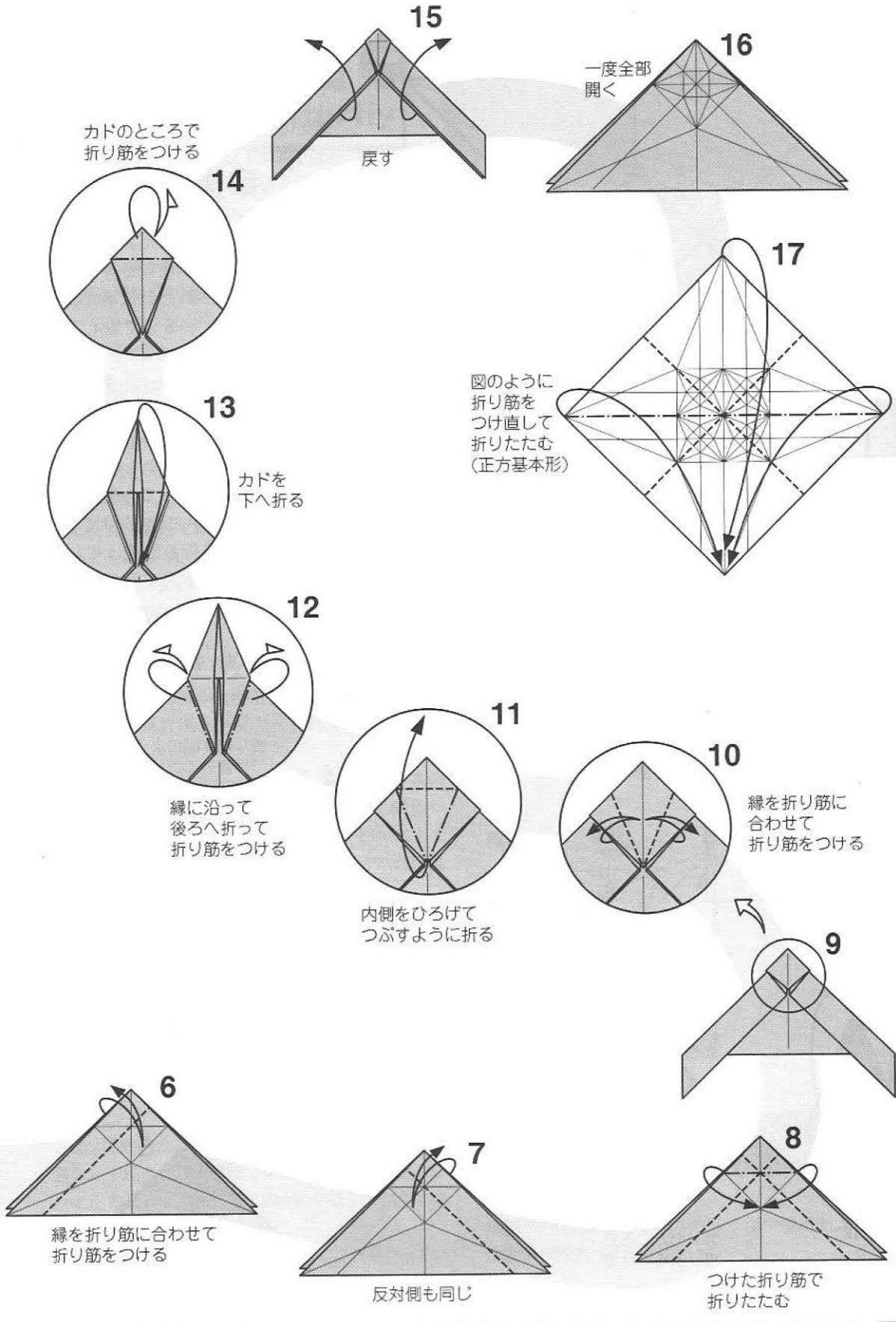

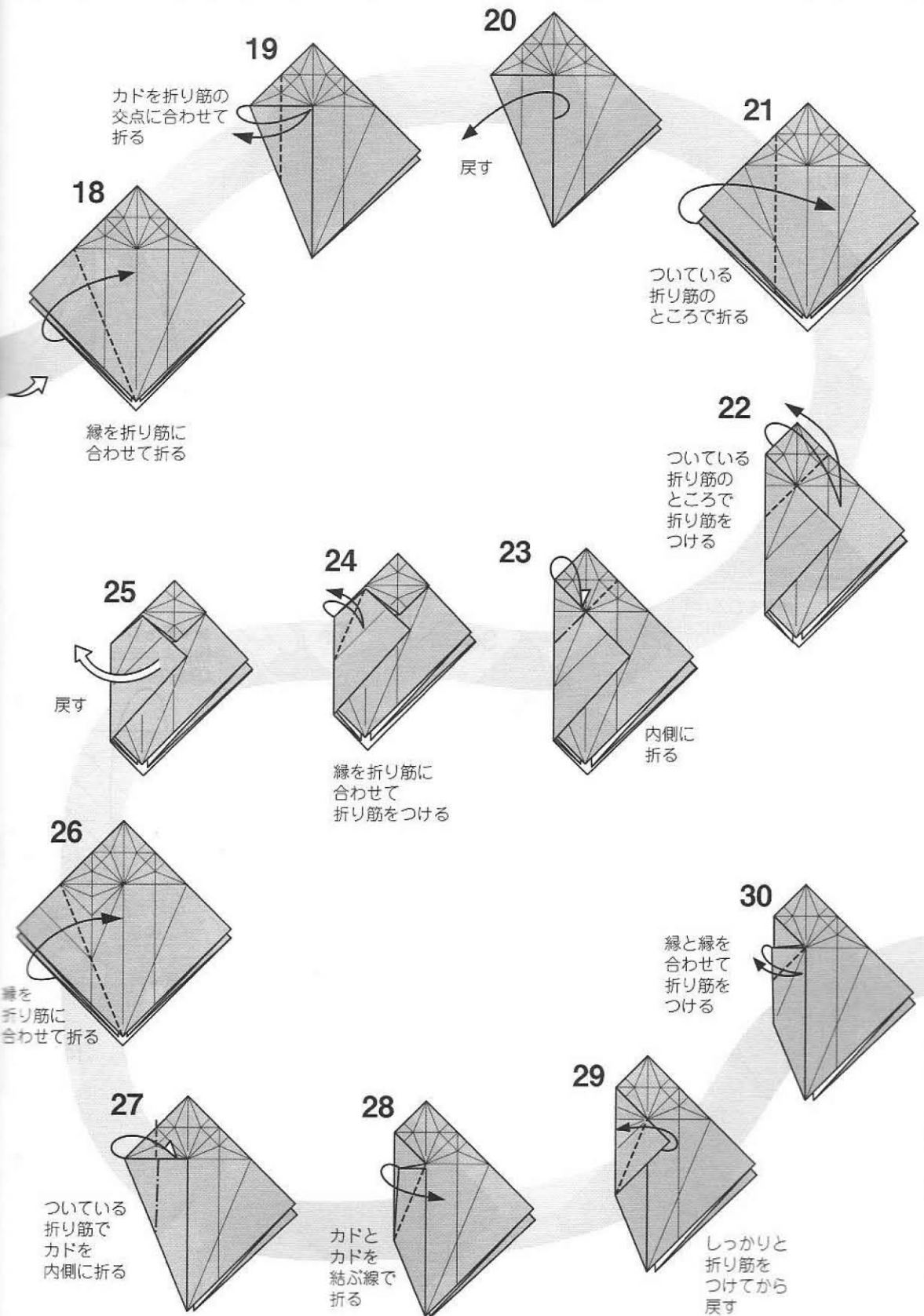

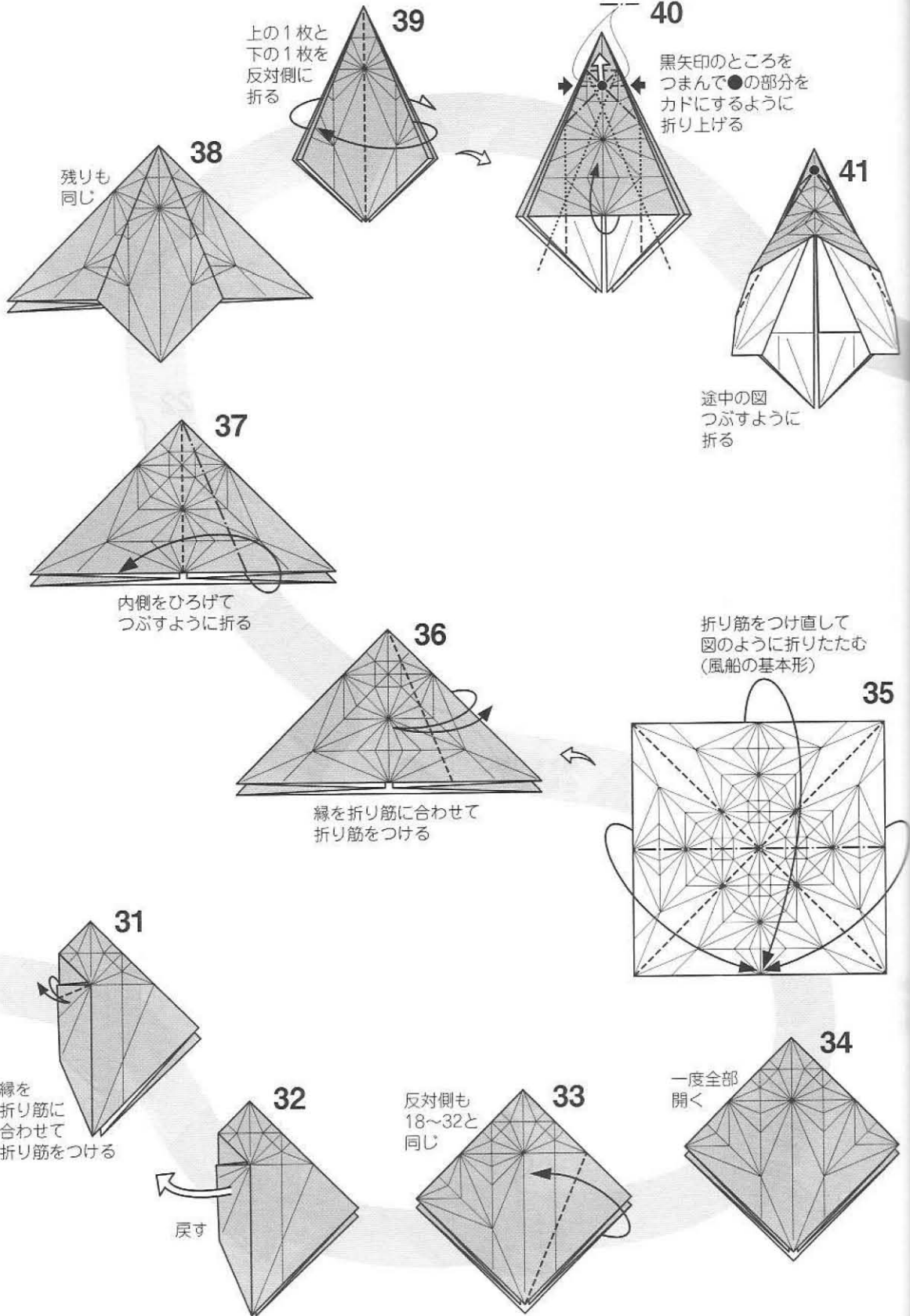

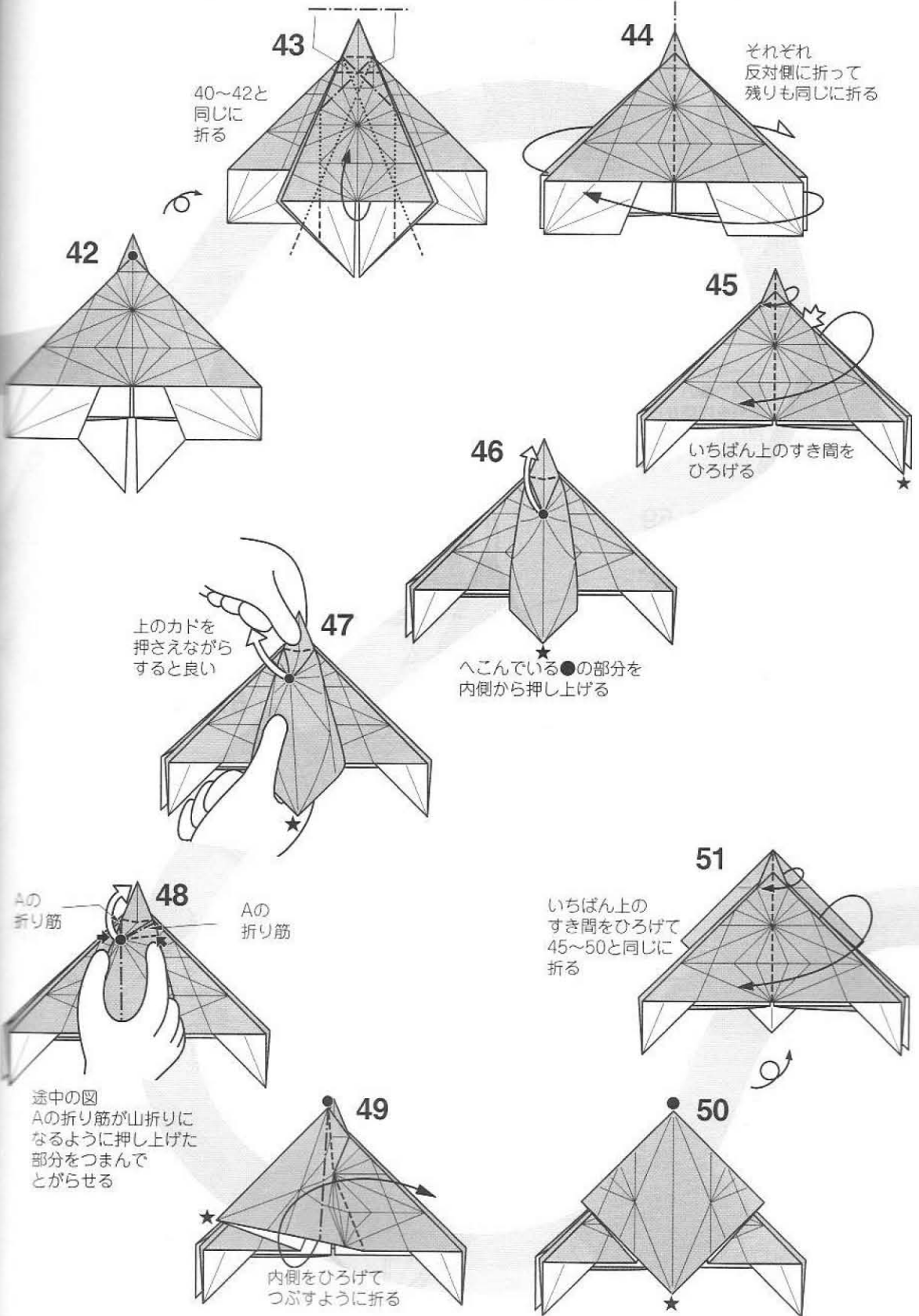

黒矢印の部分を
押し込んで
■の部分
を
平らにする

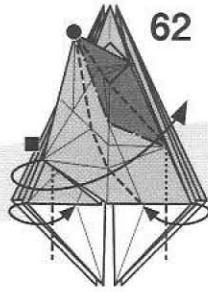
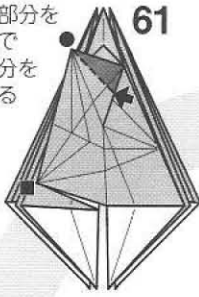

■の部分
を
閉じるようにして
折りたたむ

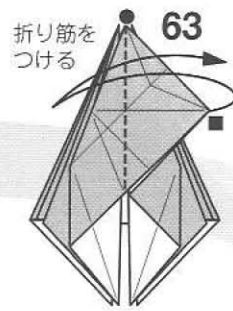

折り筋を
つける

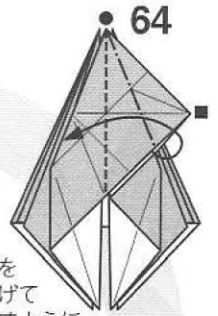

内側を
ひろげて
つぶすように
折る

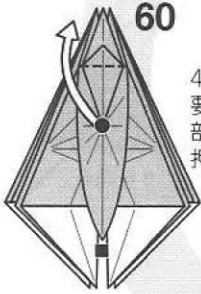

46~48の
要領で●の
部分を内側から
押し上げる

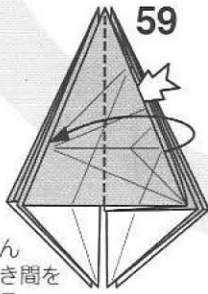

いちばん
上のすき間を
ひろげる

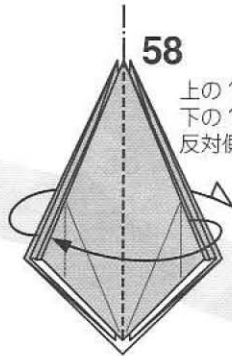

上の1枚と
下の1枚を
反対側に折る

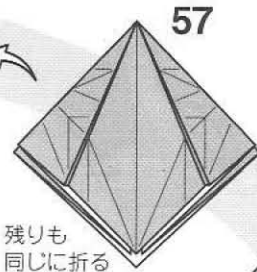

残りも
同じに折る

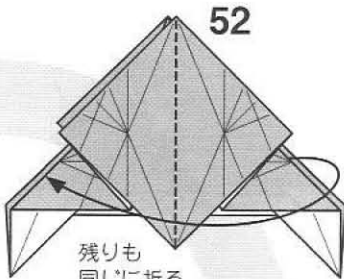

残りも
同じに折る

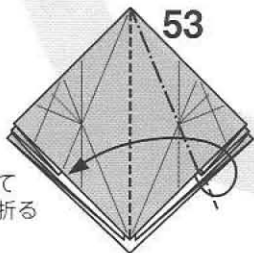

内側をひろげて
つぶすように折る

カドを
反対側に
折る

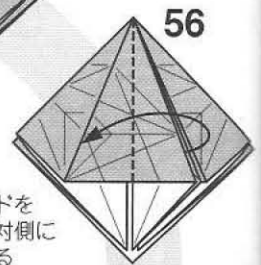
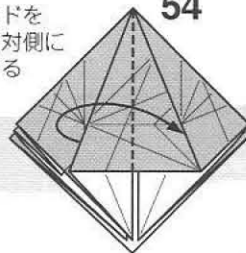

カドを
反対側に
折る

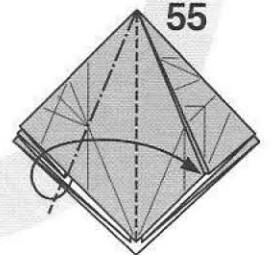

内側をひろげて
つぶすように折る

■と●のカドを
合わせて
■の部分
を沈めるように
折りたたむ

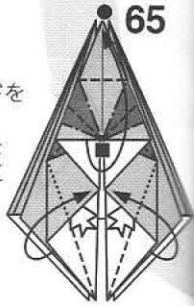

76

内側を
ひろげて
つぶすように
折る

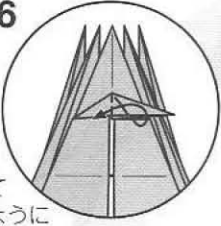

77

戻す

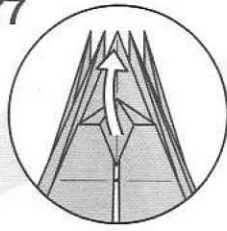

78

2つのカドを
開くところで
下に折る

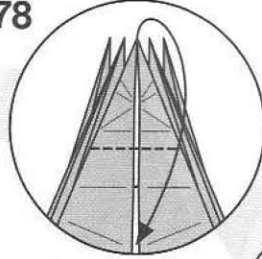

79

上の1枚を
反対側に折る

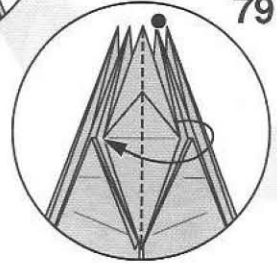

75

カドをつまむ
ように折る

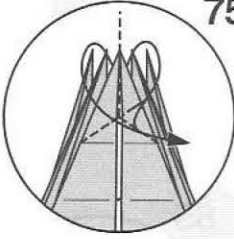

74

縁をつけた
折り筋に
合わせて
折り筋をつける

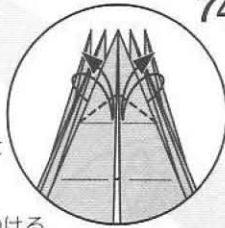

66

途中の図

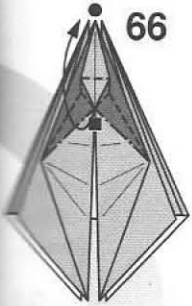

73

カドが開くところより
少し上で折り筋をつける

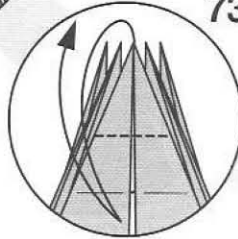

72

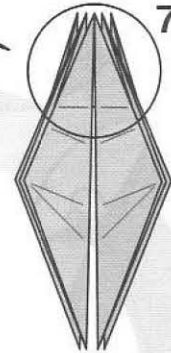

67

残りも同じに
折る

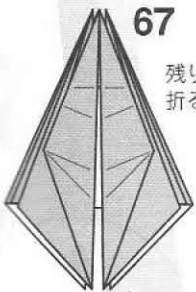

71

上の2枚と
下の2枚を
反対側に
折る

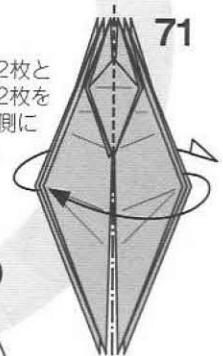

68

カドを
開くところで
下に折る

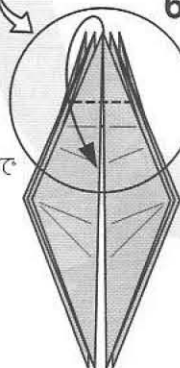

69

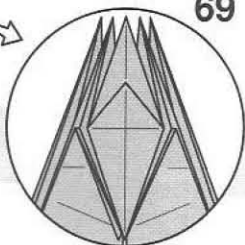

カドを
下に折る

70

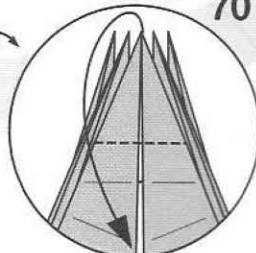

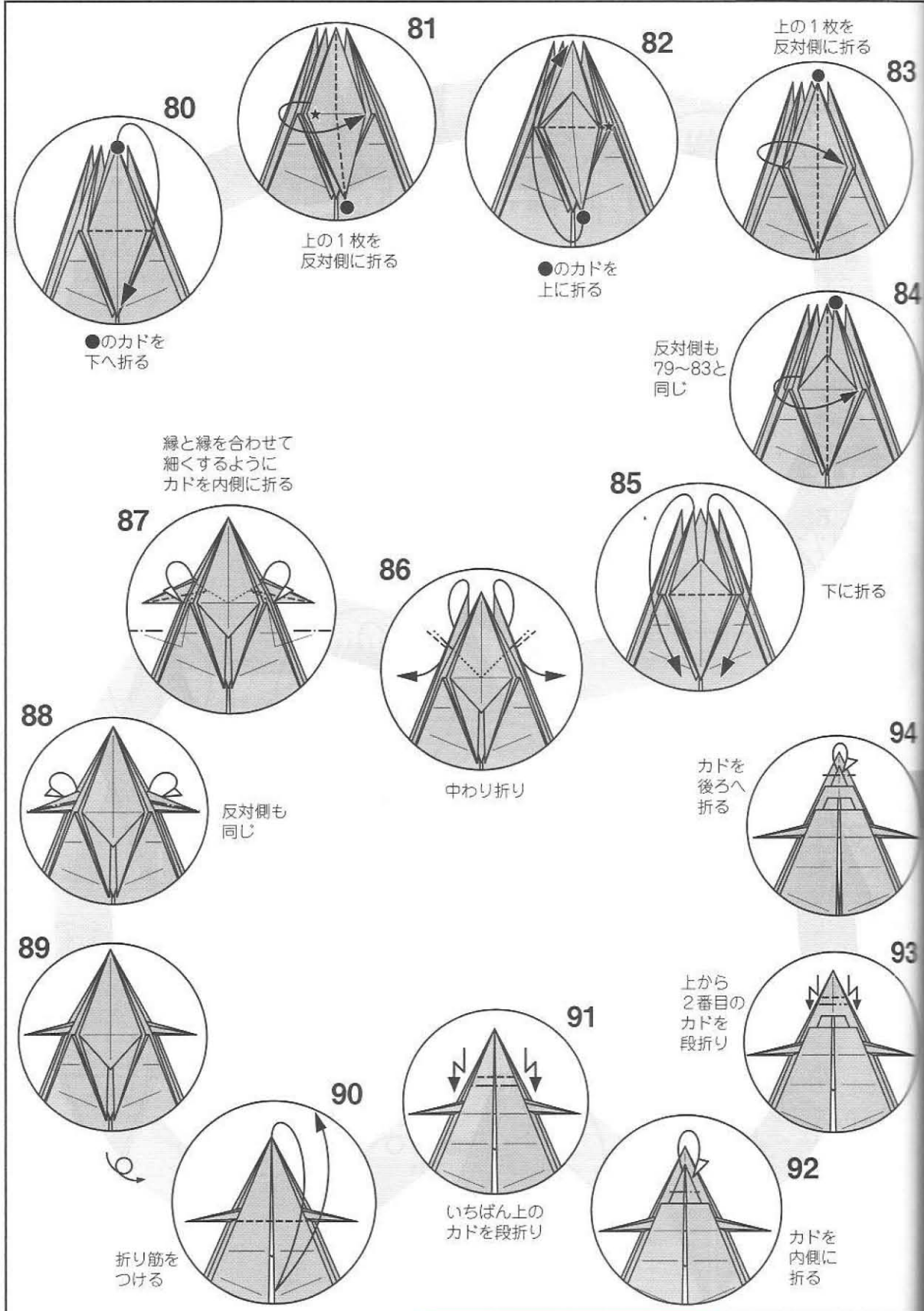

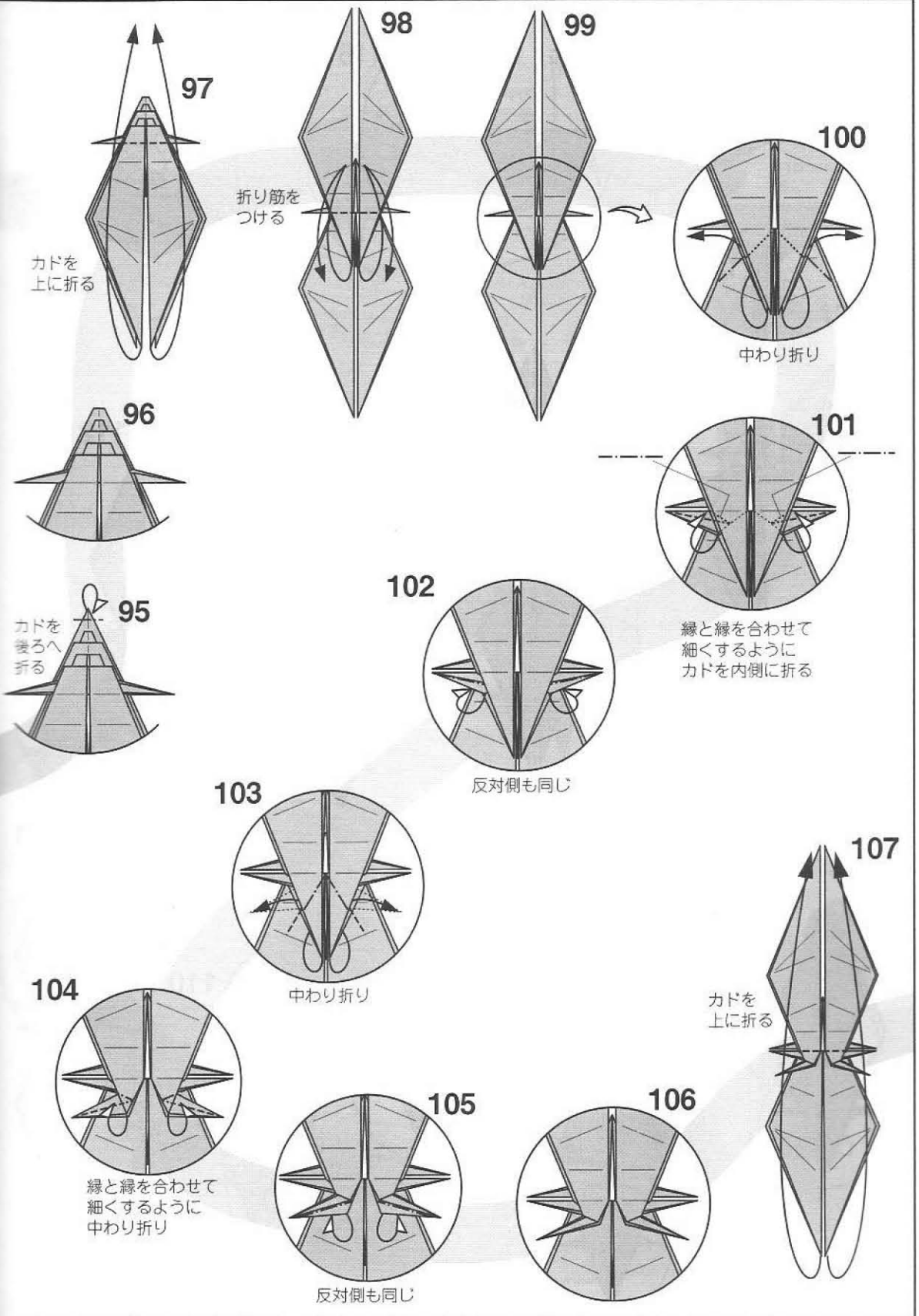

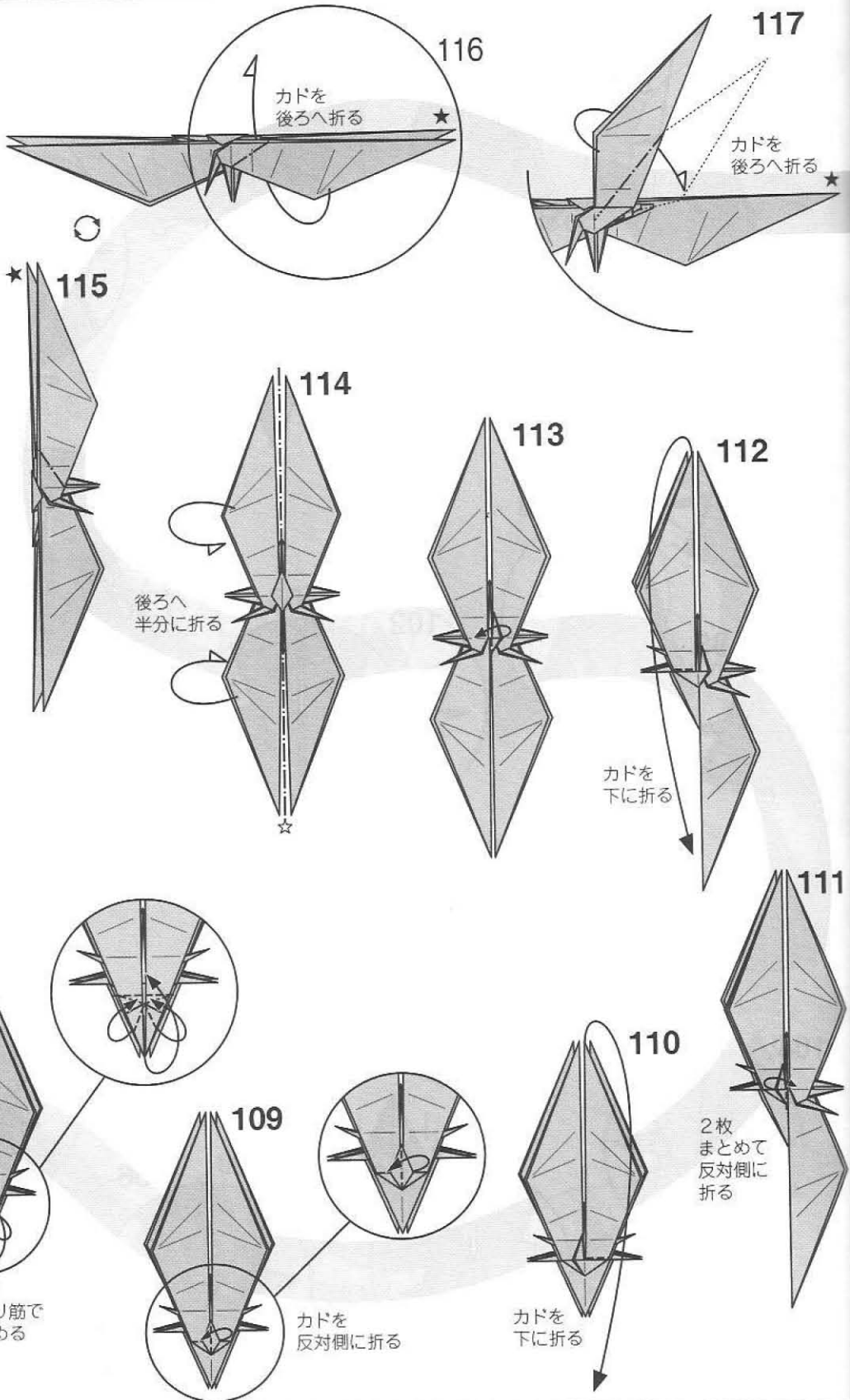

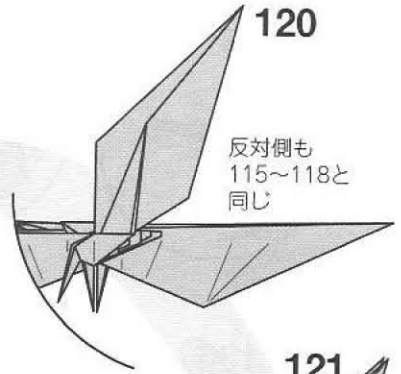
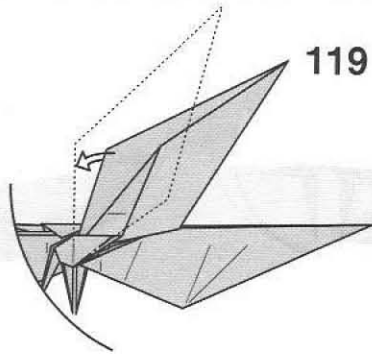
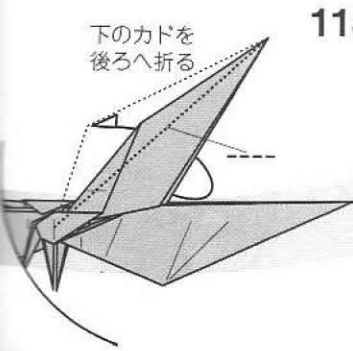

カドをつまんで
ずらすように折る

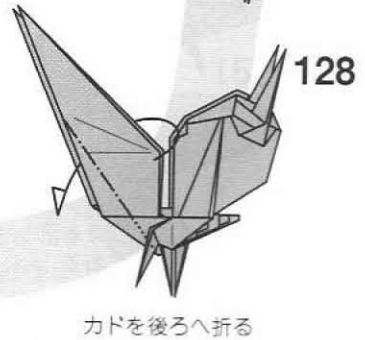
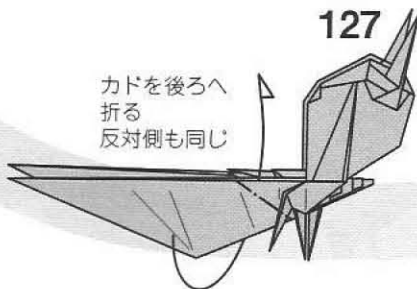
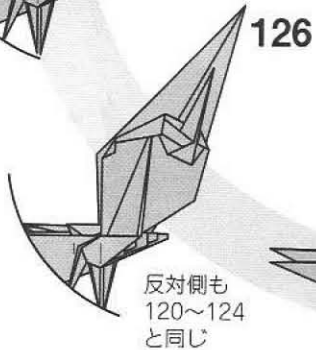
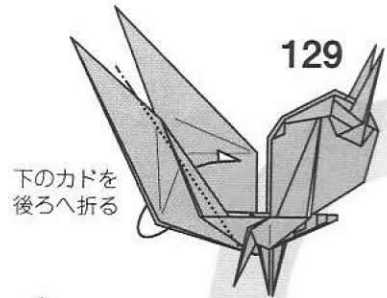
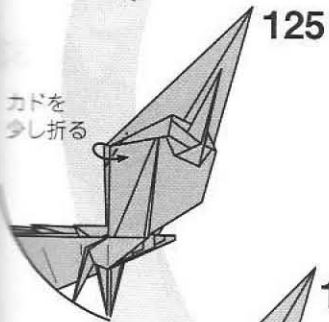
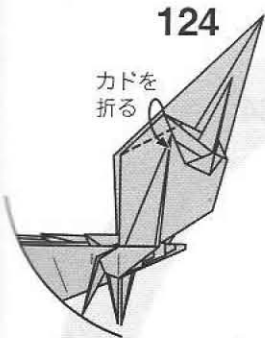
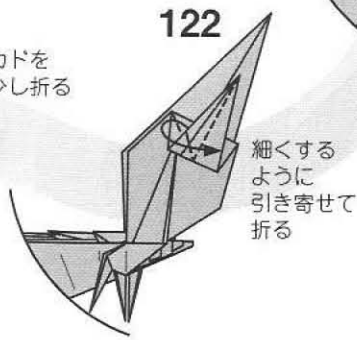
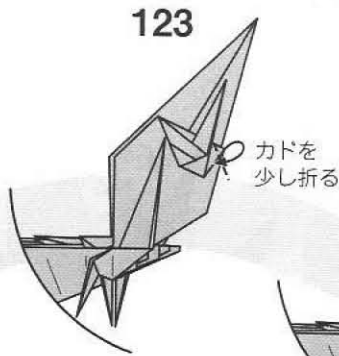
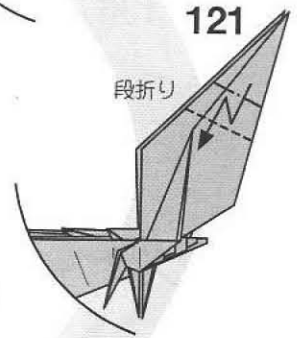

反対側も
同じ

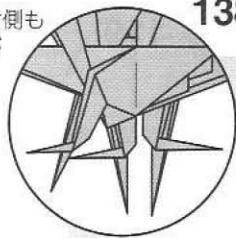

138

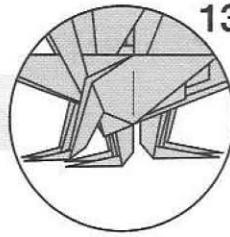

139

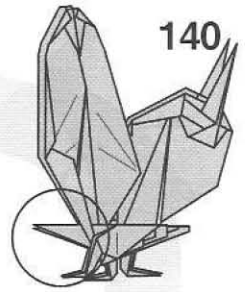

140

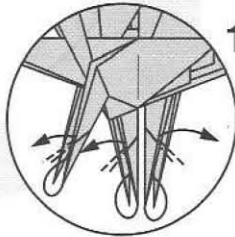

137

それぞれ
中わり折り

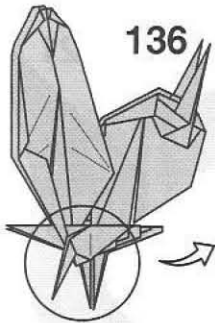

136

■の部分
を内側に斜めに
段折りして
★のカドを
カドとカドの
すき間に通す

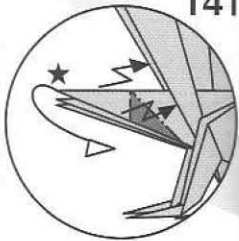

141

反対側も
127~133と
同じ

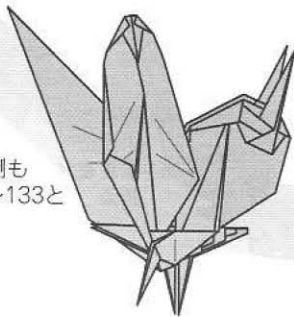

135

それぞれカドを
少し折る

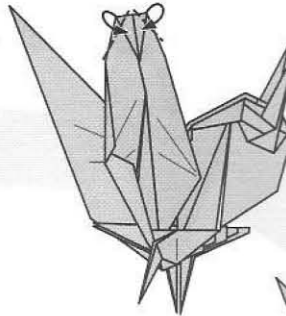

134

カドを
折り下げる

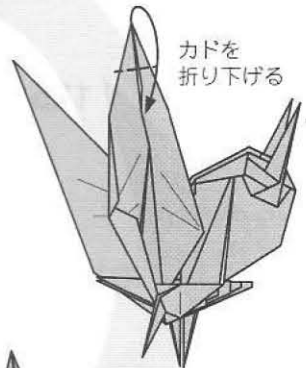

133

カドをつまんで
ずらすように
折る

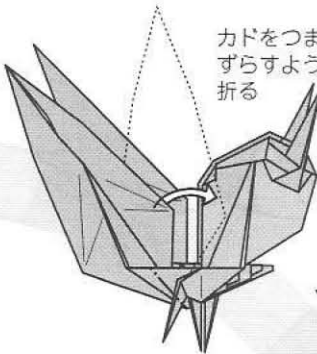

130

カドを細く
するように
折る

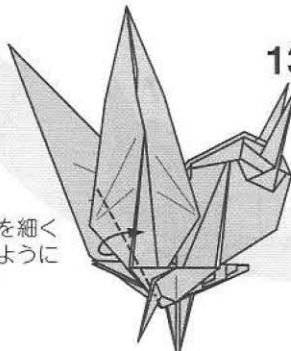

131

カドを
少し折る

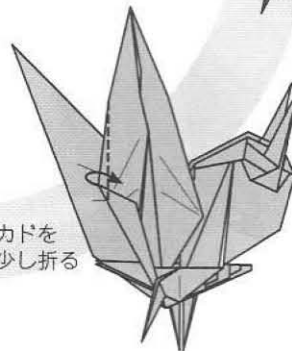

132

143



反対側も
同じ

144

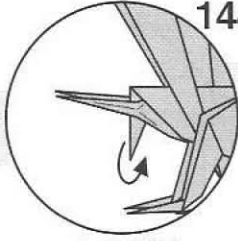

カドの先を
丸めるように
折る

145

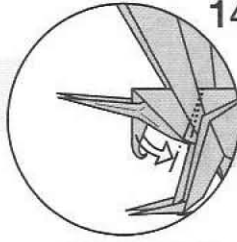

かぶせるように
斜めに段折り

146

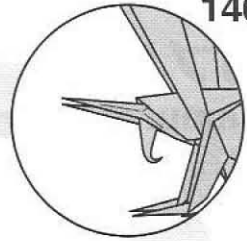

142

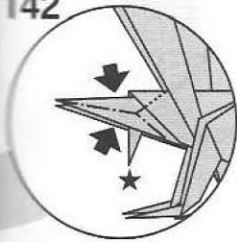

カドを
つまんで
細くする

149

反対側も
同じ

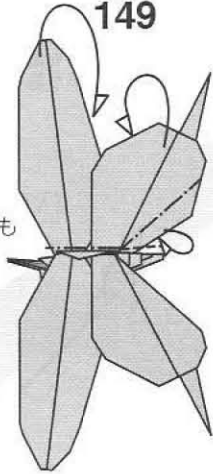

148

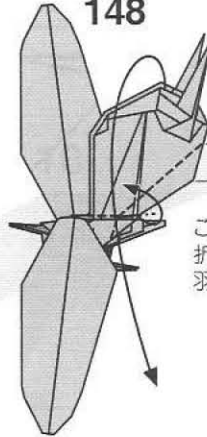

この部分を
折り上げながら
羽を折り下げる

147

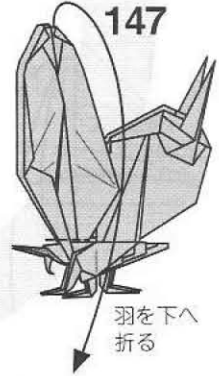

羽を下へ
折る

150

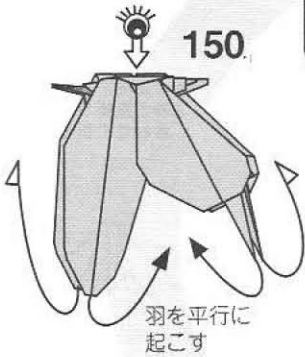

羽を平行に
起こす

153

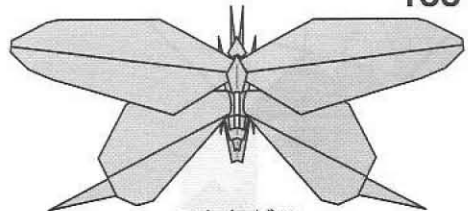

できあがり

151

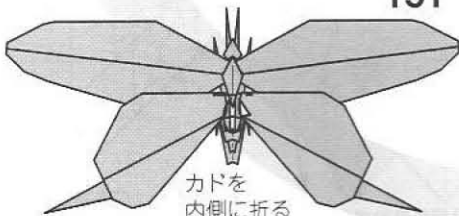

カドを
内側に折る

152

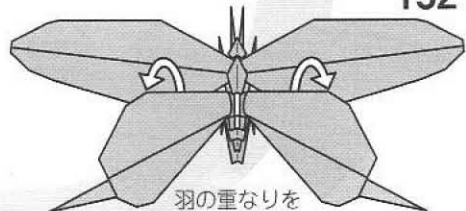

羽の重なりを
入れ替える

カブトムシ 2.1

Samurai Helmet Beetle 2.1

神谷哲史
Model & Diagrams by Satoshi Kamiya
作 2002-2007

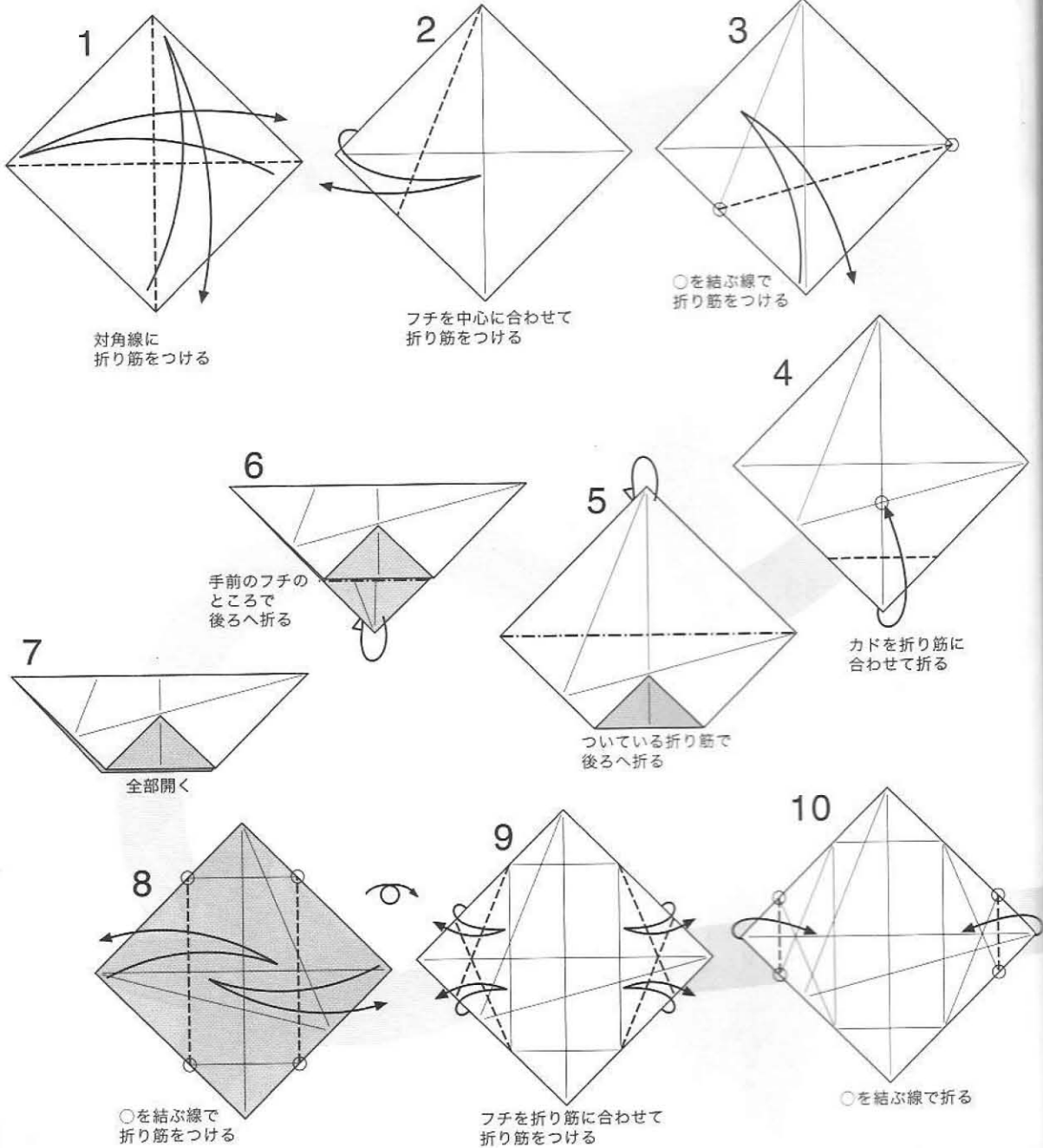
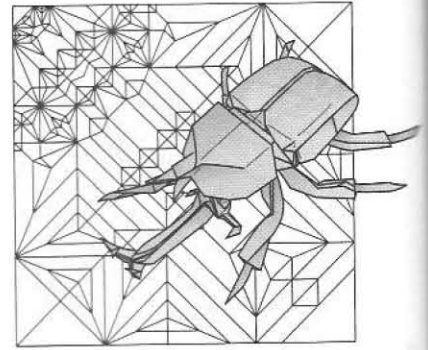

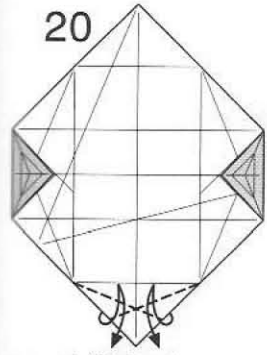

フチを折り筋に合わせて折り筋をつける

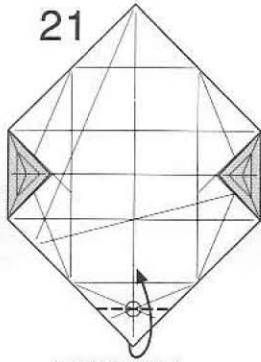

カドを○を通る線で折る

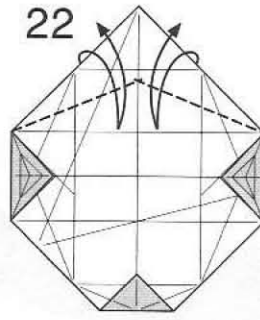

フチを折り筋に合わせて折り筋をつける

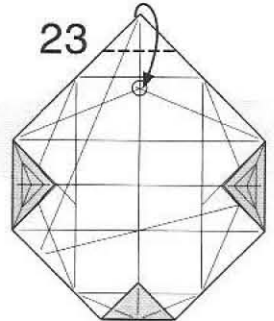

カドを折り筋に合わせて折る

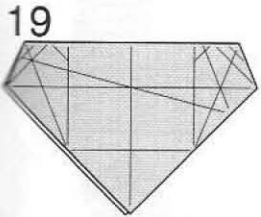

14の形に戻す

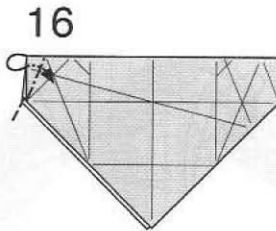

中割り折り

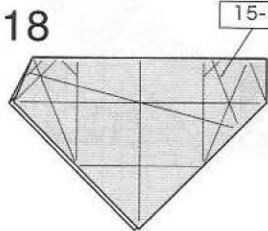

反対側も15-17と同様に折る

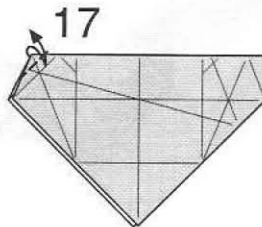

カドを折り筋に合わせて折る

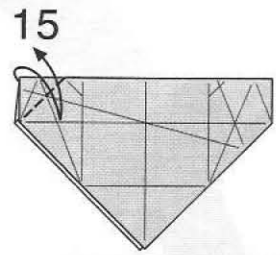

フチを折り筋に合わせて折り筋をつける

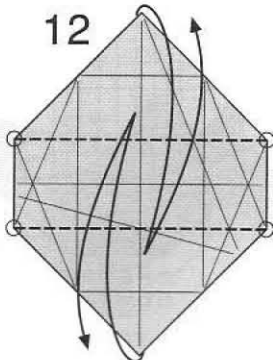
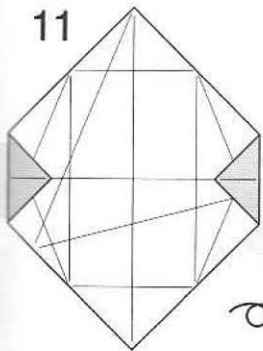

カドを結ぶ線で折り筋をつける

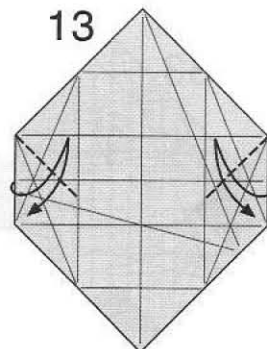

フチを折り筋に合わせて折り筋をつける

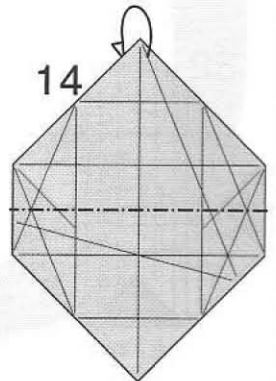

半分に後ろへ半分に折る

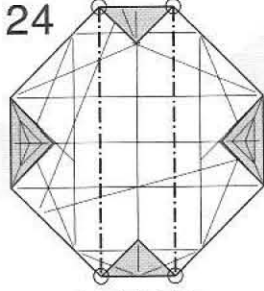

カドを結ぶ線で
折り筋をつける

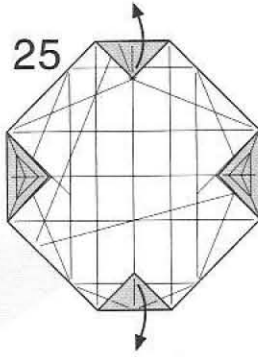

カドを広げる

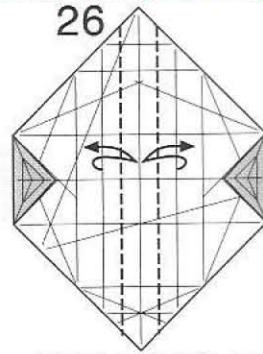

折り筋と折り筋を合わせて
折り筋をつける

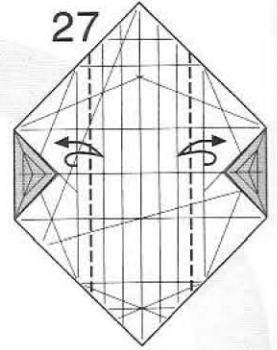

折り筋と折り筋を合わせて
折り筋をつける

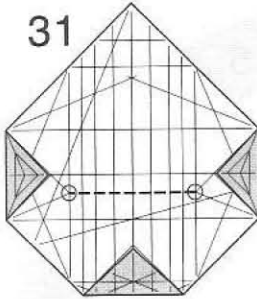

○を結ぶ線で
折り筋をつける

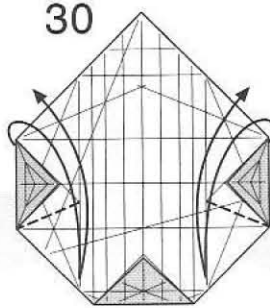

カドを折り筋に合わせて
折り筋をつける

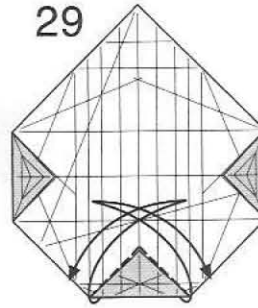

フチのところで
折り筋をつける

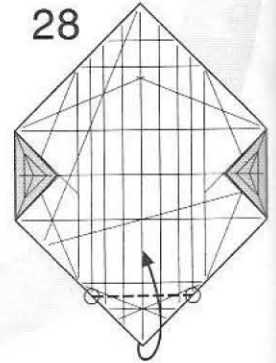

カドを
○を結ぶ線で折る

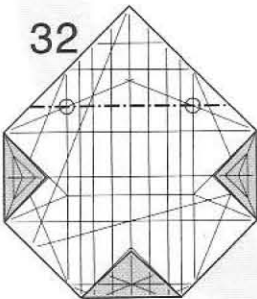

○を結ぶ線で
折り筋をつける

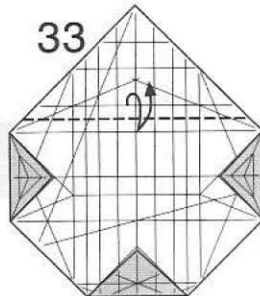

折り筋と折り筋を合わせて
折り筋をつける

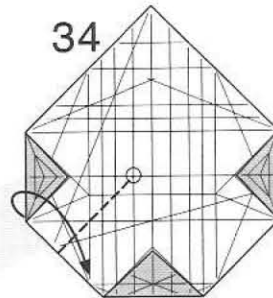

カドを折り筋に
合わせて折る

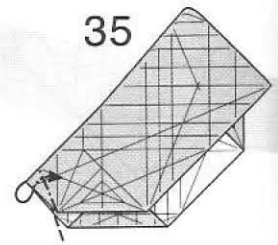

中割り折り

45

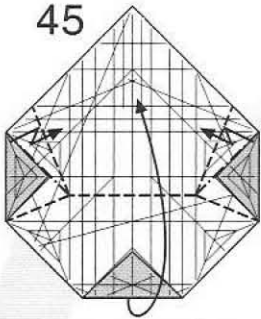

ついている折り筋を使って
折り畳む

46

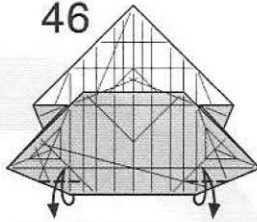

フチを折り筋に合わせて
折り筋をつける

48

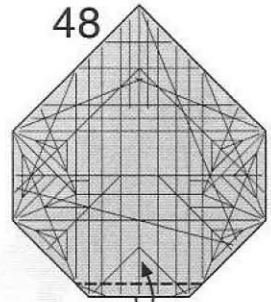

フチをついている
線で折る

47

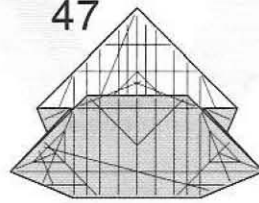

45 の形に戻す

44

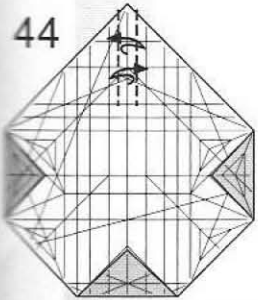

折り筋と折り筋を合わせて
折り筋をつける

43

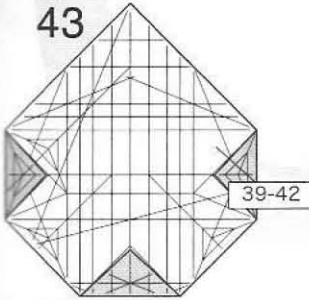

反対側も 39-42 と
同様に折る

42

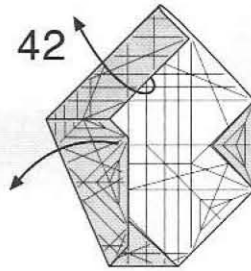

39 の形に戻す

41

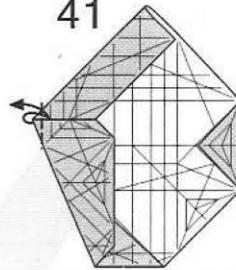

カドを折り筋に合わせて
折り筋をつける

40

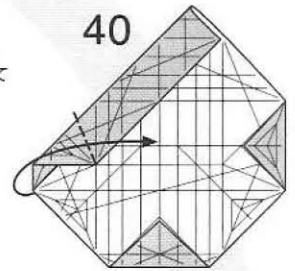

フチを中心線に
合わせて折る

36

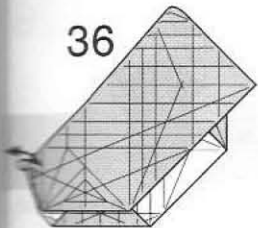

カドを折り筋に合わせて
折り筋をつける

37

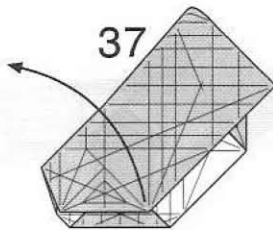

35 の形に戻す

38

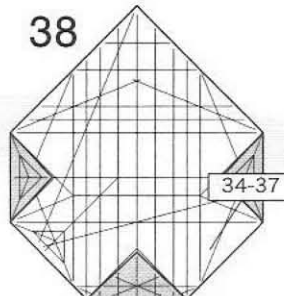

反対側も 34-37 と
同様に折る

39

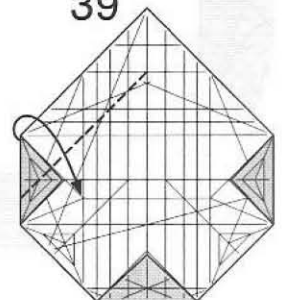

カドを折り筋の交点に
合わせて折る

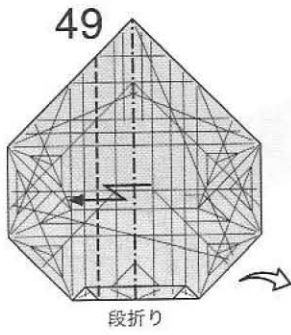

段折り

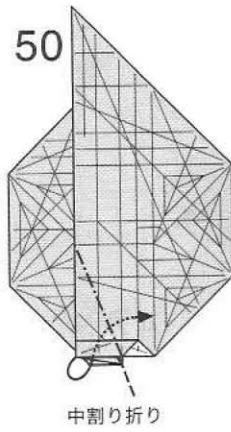

中割り折り

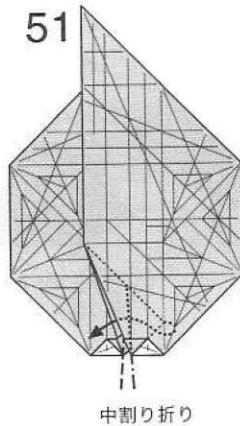

中割り折り

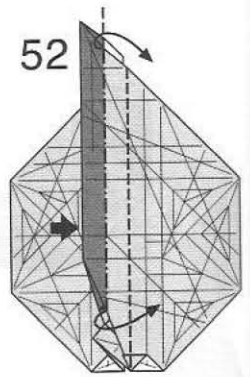

内側を広げて
■の部分をつぶすように折る

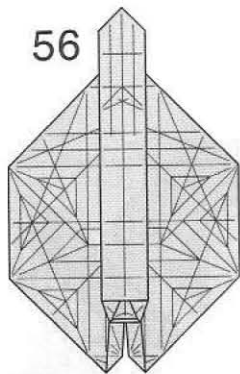

56

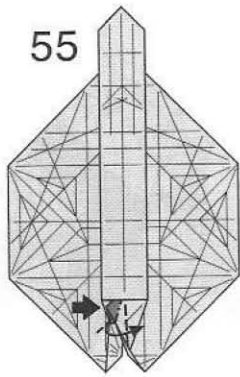

■の部分を広げてつぶすように折る

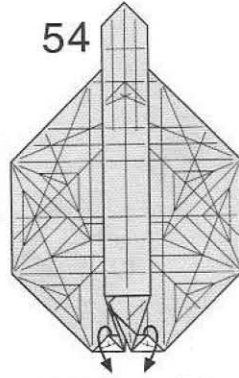

カドを下に引き出す

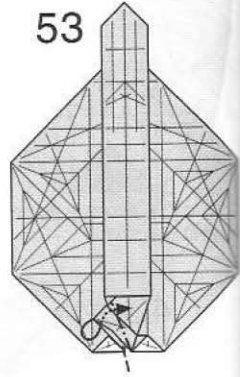

53

中割り折り

6

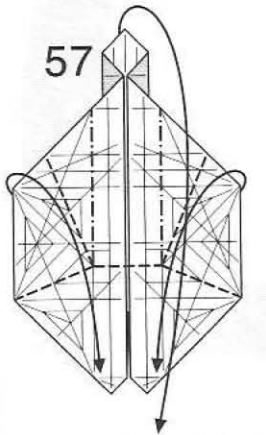

ついている折り筋を使って折り畳む

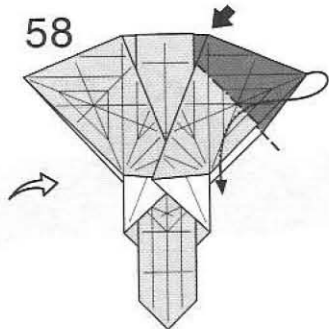

奥の部分をしずめ折り (Closed sink) しながら中割り折り

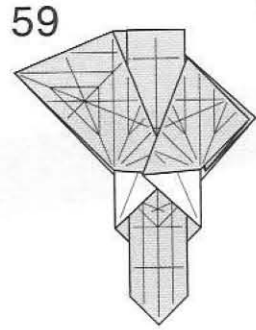

軽く広げる

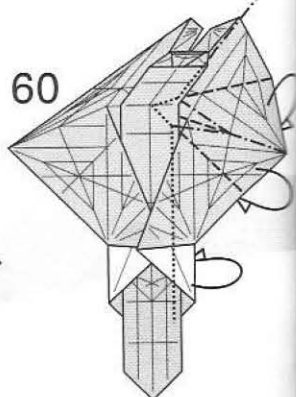

フチを内側に折り込むようについている折り筋を使って折り畳む

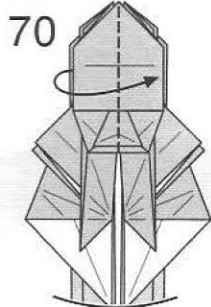

ヒダを反対側に折る

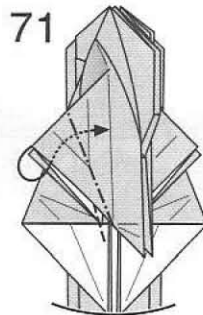

中割り折り

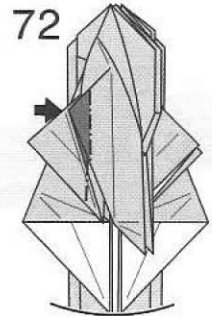

しずめ折り

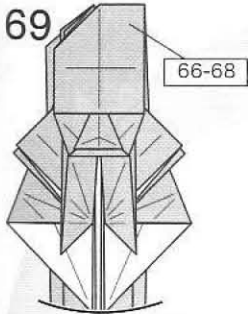

反対側も 66-68 と同様に折る

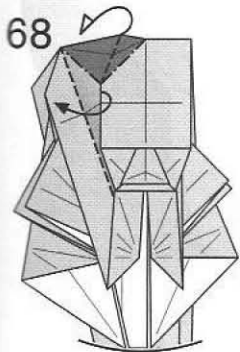

平らに折り畳む

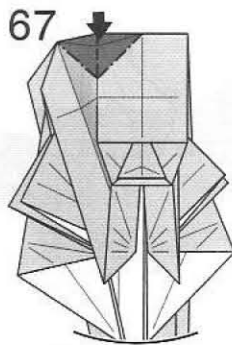

■の部分をつぶす

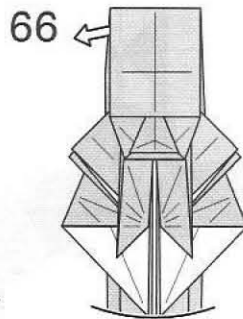

ヒダを広げる

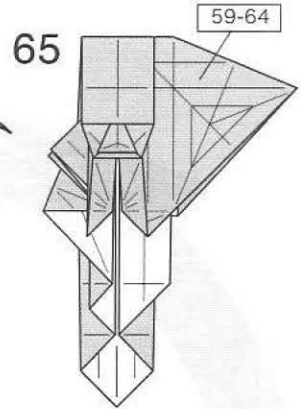

反対側も 59-64 と同様に折る

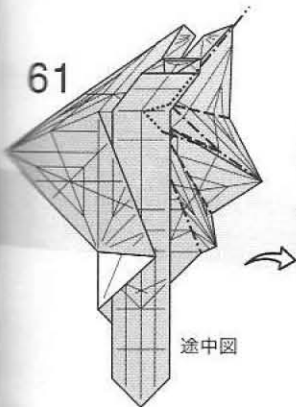

途中図

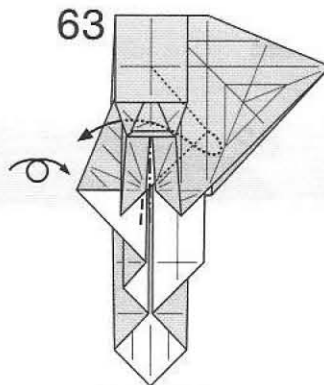
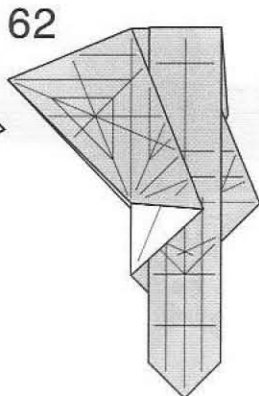

内側のカドを中割り折り

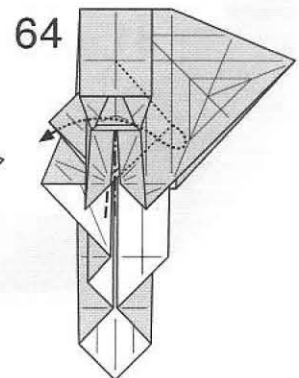

もう1つのカドも中割り折り

73

71-72

後ろの部分も
71-72と同様に折る

74

閉じる

75

70-74

反対側も 70-74と
同様に折る

76

77

カドを上にする

78

内側を広げて
カドを下に折る

79

そのまま折り進む

80

ついている折り筋で
段折りするように
折り進む

81

ついている
折り筋を使って
折り進む

82

平らに折り畳む

83

78-82

反対側も 78-82と
同様に折る

84

ずらすように折る

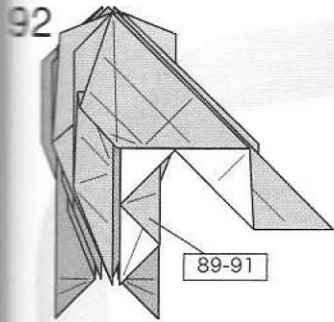

反対側も 89-91 と同様に折る

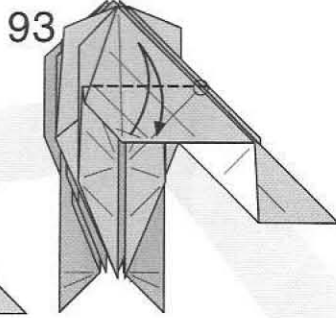

○のところで折り筋をつける

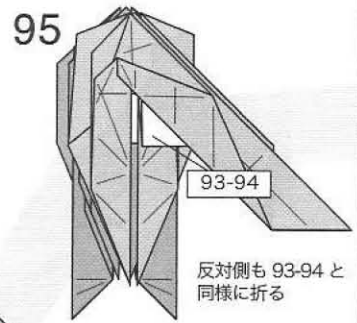

93-94

反対側も 93-94 と同様に折る

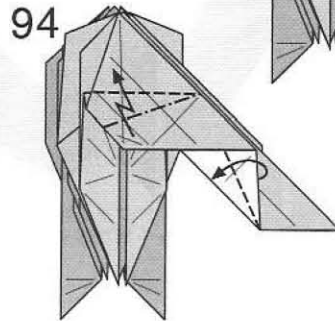

ずらすように段折り

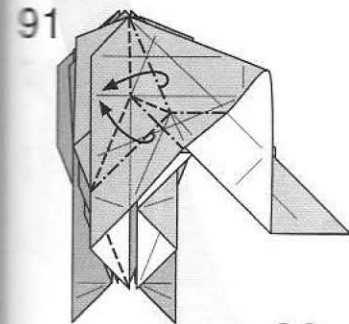

ついている折り筋を使ってつまむように折り畳む

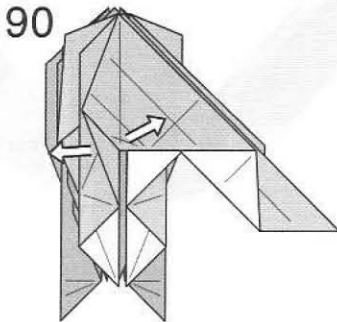

軽く広げる

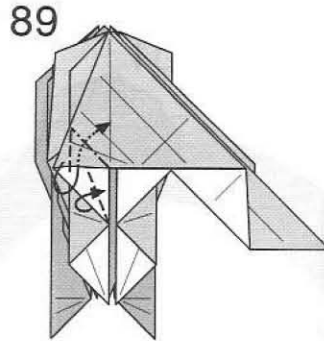

フチとフチを合わせて中割り折りするように折る

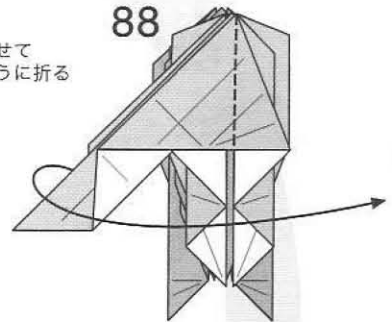

カドを反対側に折る

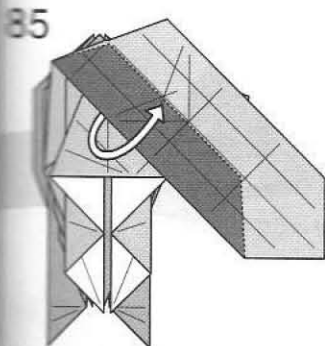

内側のカドを外に出す

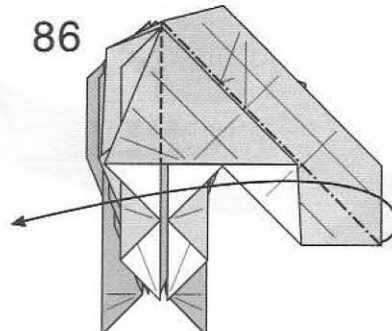

つまむようにして反対側に折る

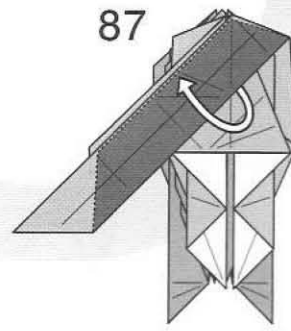

内側のカドを外に出す

96

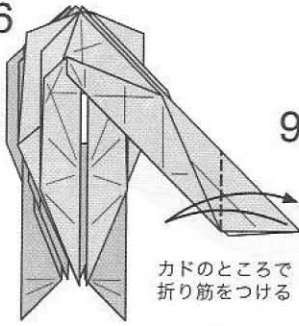

カドのところで
折り筋をつける

97

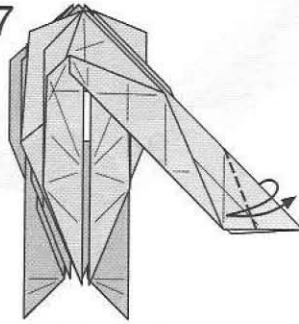

フチを折り筋に合わせて
折り筋をつける

98

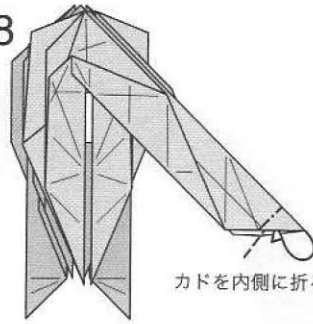

カドを内側に折る

99

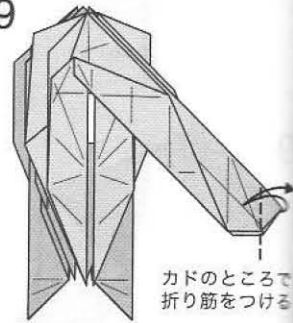

カドのところで
折り筋をつける

102

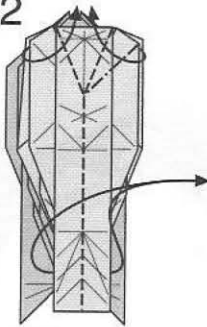

大きく
つまむように折る

101

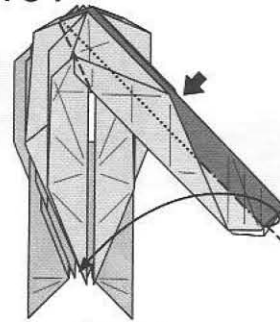

内側を広げて
■の部分
つぶすように折る

100

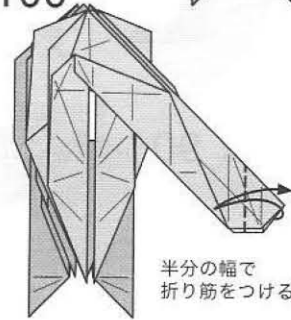

半分の幅で
折り筋をつける

103

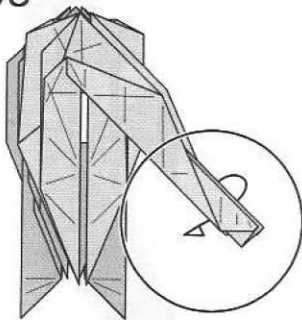

カドの先を
広げる

104

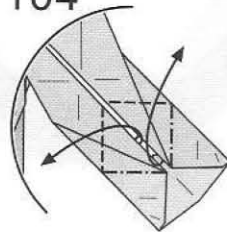

内側を広げて
つぶすように折る

105

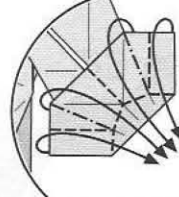

ついている折り筋を使って
カドが1ヶ所に集まるように
折り畳む

106

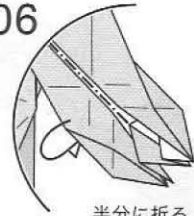

半分に折る

107

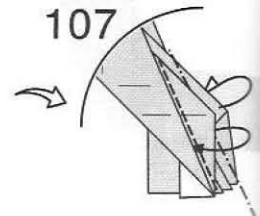

カドを隙間に折り込む

118

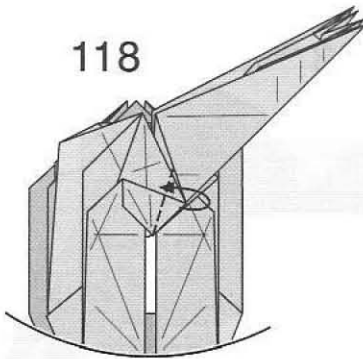

フチを折り筋に合わせて折る

119

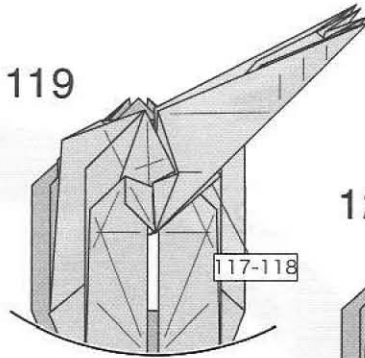

反対側も 117-118 と同様に折る

120

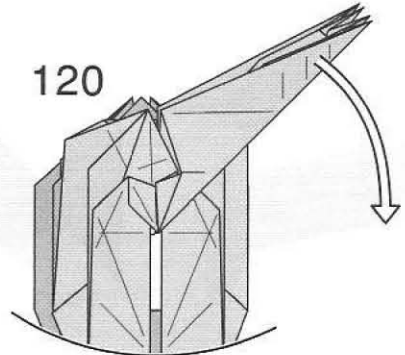

カドをずらすように引き出す

117

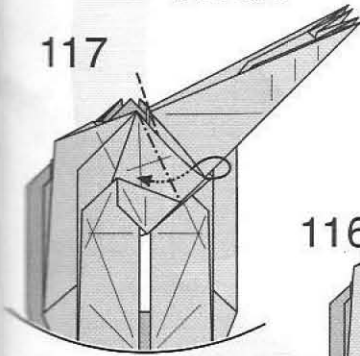

中割り折り

116

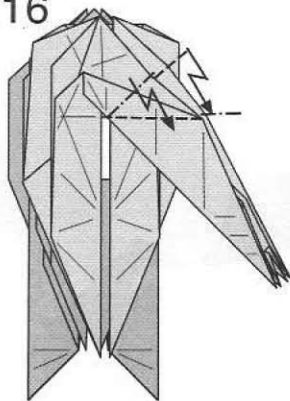

両側で段折り

115

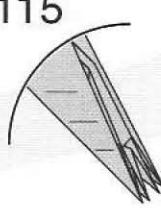

114

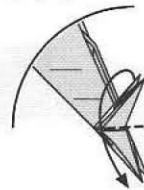

閉じる

113

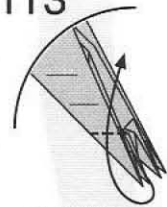

カドを斜めに折って起き上がってきたカドをつぶすように折る

109

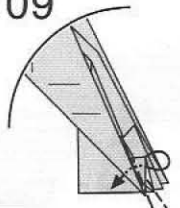

中割り折り

110

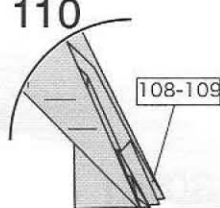

反対側も 108-109 と同様に折る

108

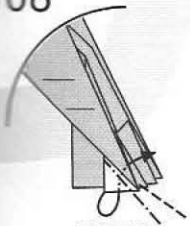

中割り折り

111

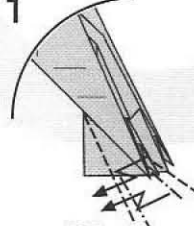

両側で段折り

112

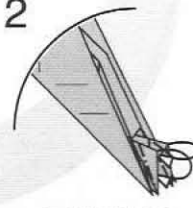

カドをあやめの基本形のように折り込む

121

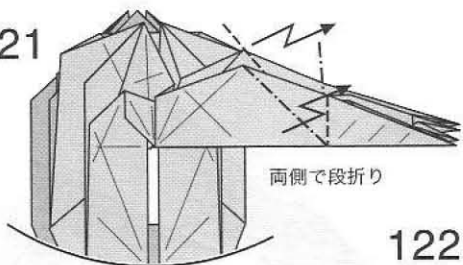

両側で段折り

123

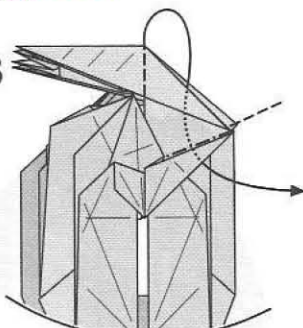

中割り折り

122

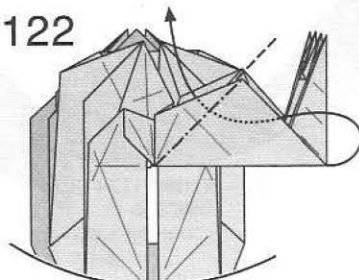

中割り折り

124

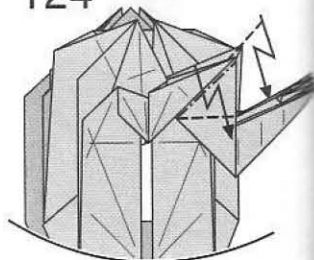

両側で
段折り

127

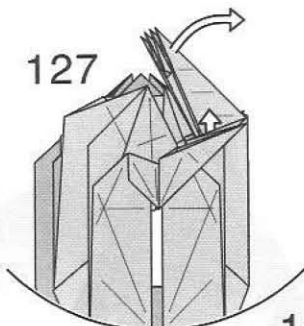

カドをずらすように
引き出す

125

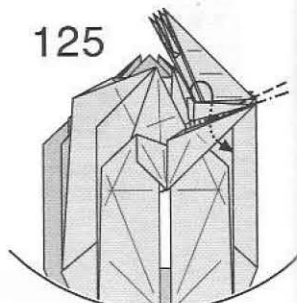

中割り折り

128

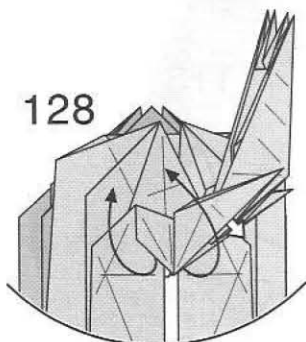

内側に折り畳まれている
紙を引き出す

126

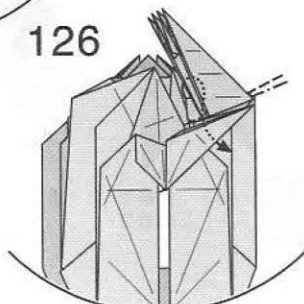

中割り折り

129

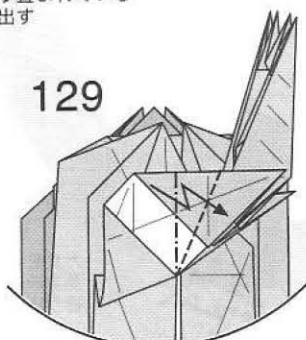

ずらすように
段折り

130

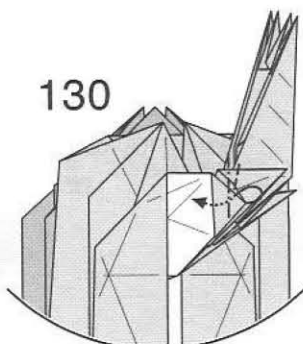

中割り折り

131

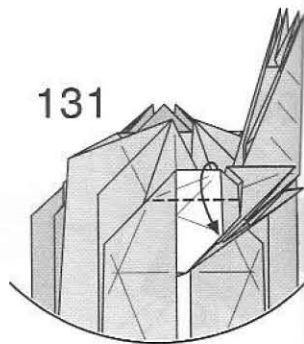

カドとカドを
合わせて折る

139

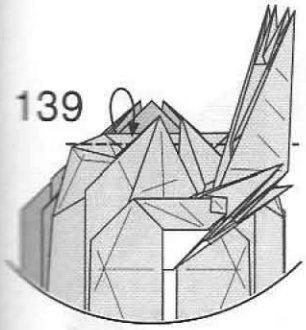

フチを少し折り込む

140

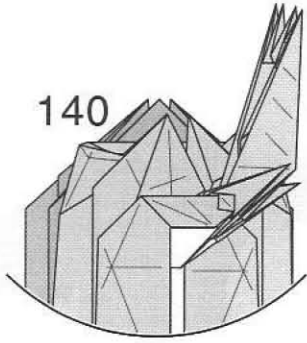

141

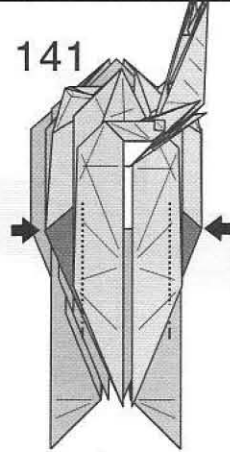

しずめ折り

142

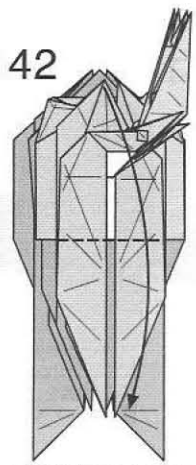

頭の部分を下に折る

138

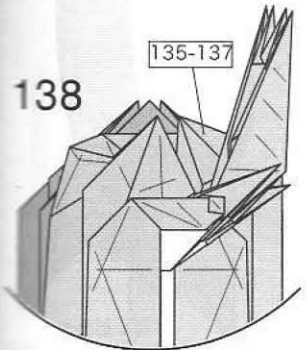

反対側も 135-137 と同様に折る

136

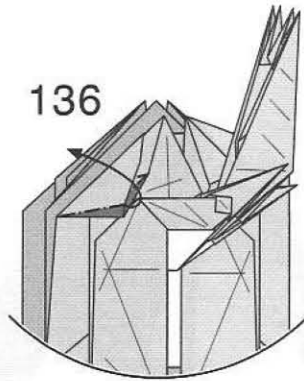

内側を広げて
■の部分をつぶすように折る

137

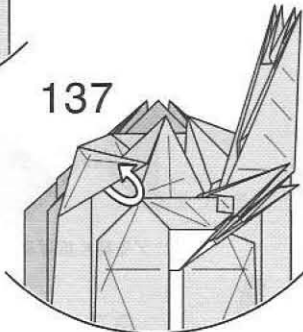

後ろの紙を手前に出す

135

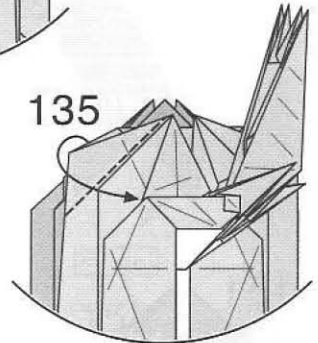

カドをフチのところで折る

132

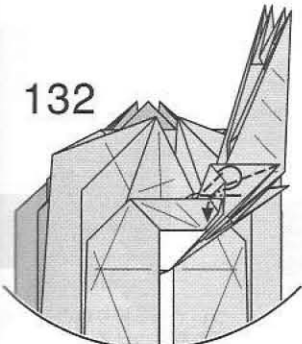

カドを中割り折りするように折る

133

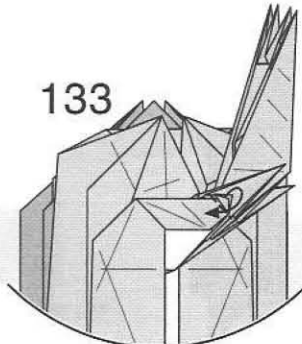

上の一枚を反対側に折って眼を作る

134

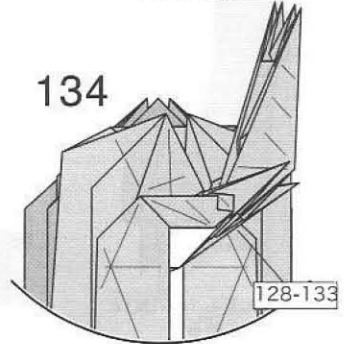

反対側も 128-133 と同様に折る

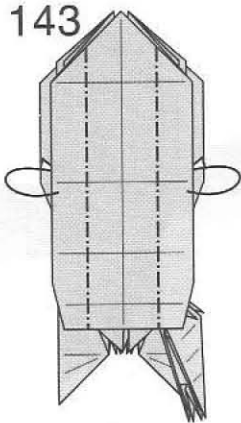

フチを後ろへ折る

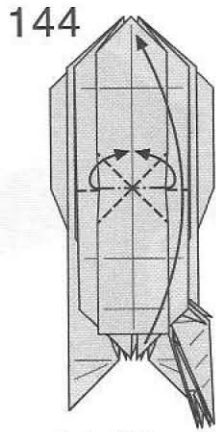

中央の部分で
中割り折りしながら
折り畳む

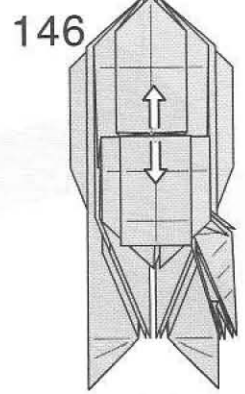
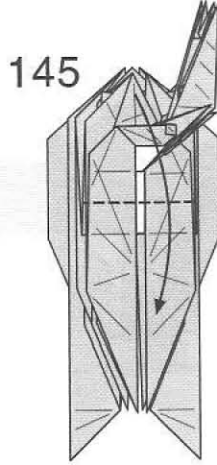

軽く広げる

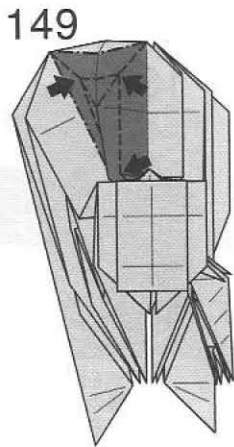
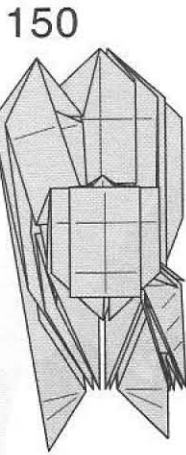

裏側の隙間に
押し込むように
折り畳む

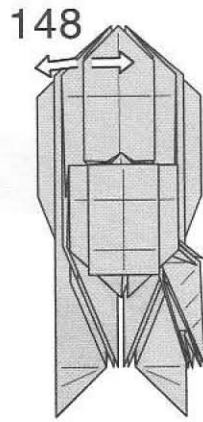

ヒダを軽く広げる

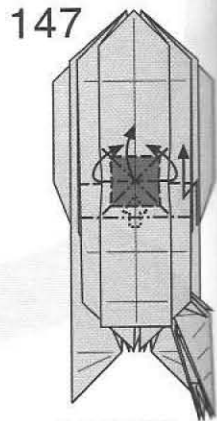

中心の部分を
押し出すように折る
(Unsink)

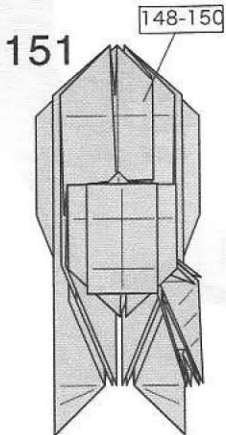

反対側も 148-150 と
同様に折る

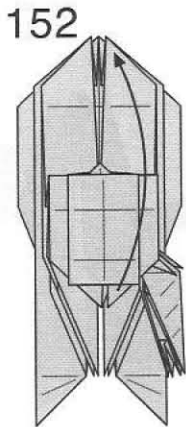

頭の部分を上に折る

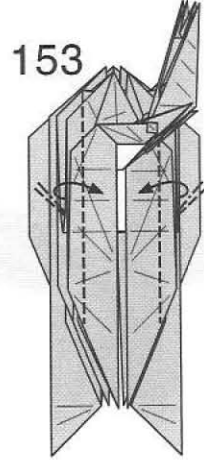

フチを下の幅に合わせて
引き寄せるように折る

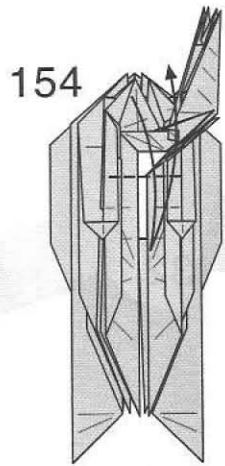

ついている折り筋のところ
折り筋をつける

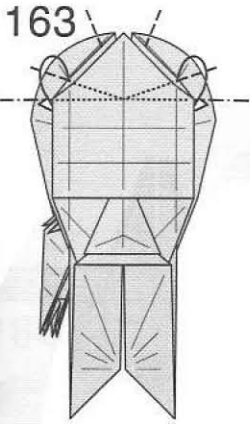

163 内側にずらすように折る

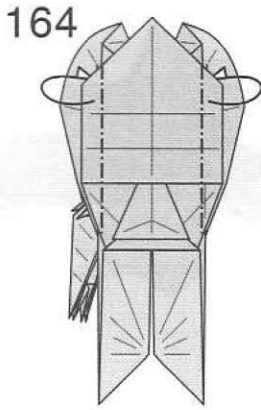

164 ついている折り筋で
後ろへ折る

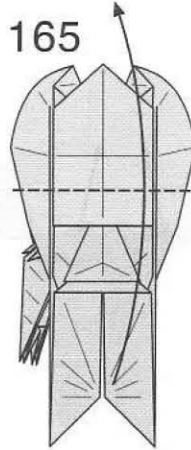

165 カドをまとめて
上に折る

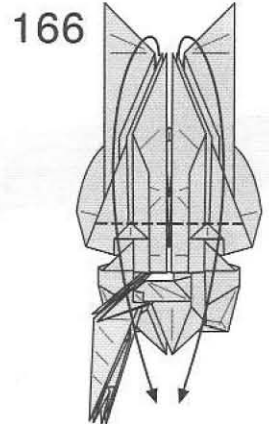

166 それぞれ2つのカドを
下に折る

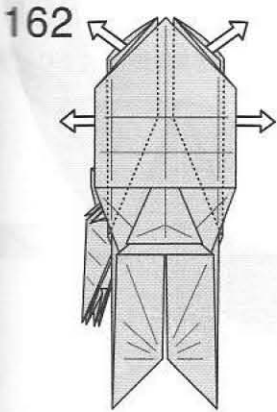

162 内側の紙を引き出して
立体にする

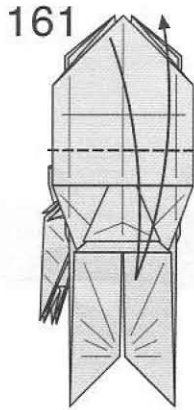

161 折り筋をつける

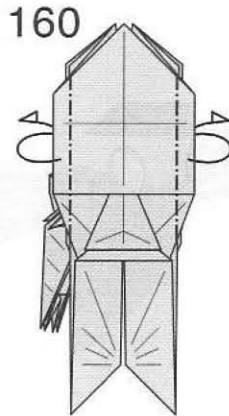

160 フチを下の幅に合わせて
折り筋をつける

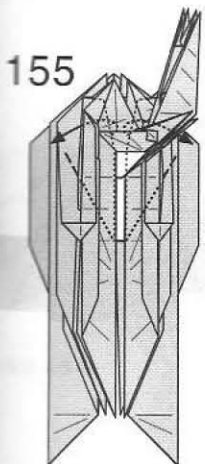
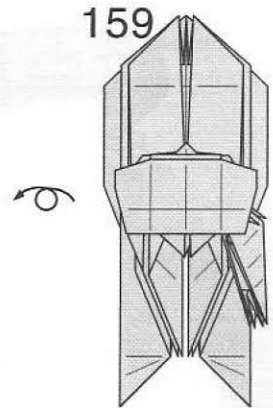

155 内側の紙を
出すように折る

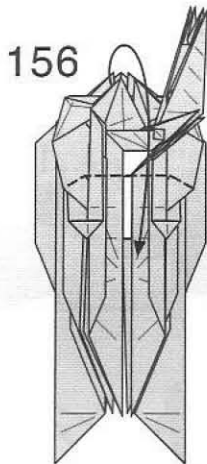

156 145 でつけた折り筋を使って
折り畳む

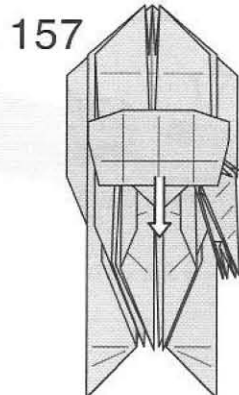

157 軽く広げるようにする

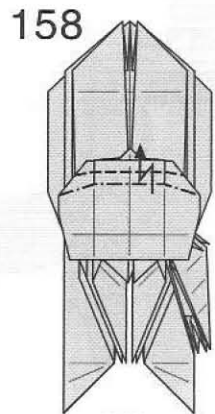

158 段折り

167

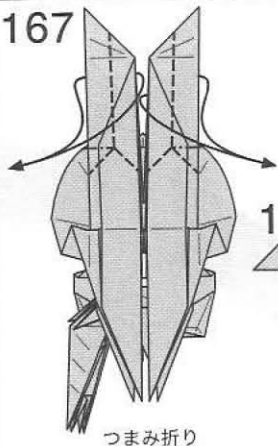

つまみ折り

168

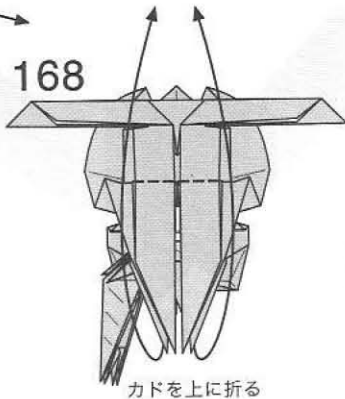

カドを上折る

169

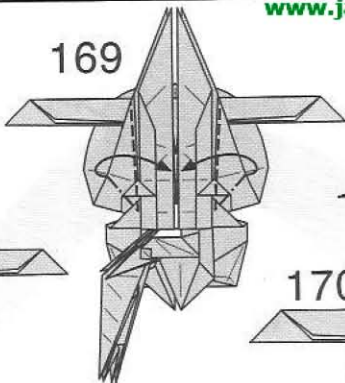

フチのところ
引き寄せるように折る

170

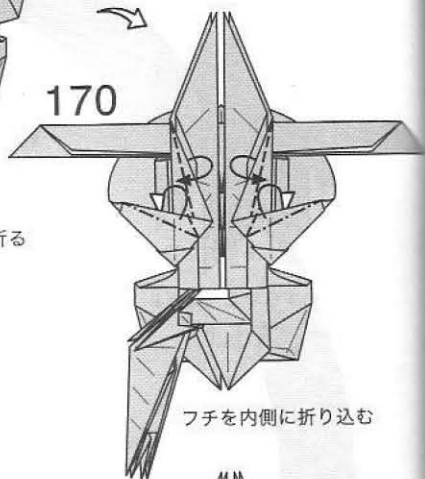

フチを内側に折り込む

173

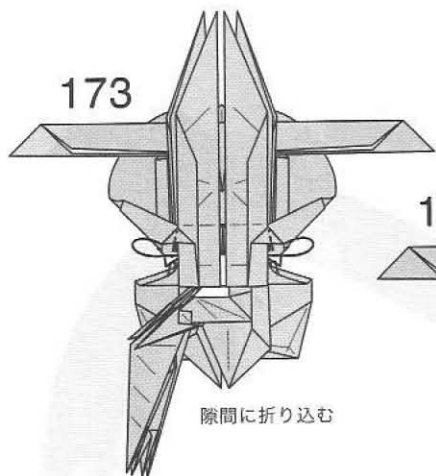

隙間に折り込む

172

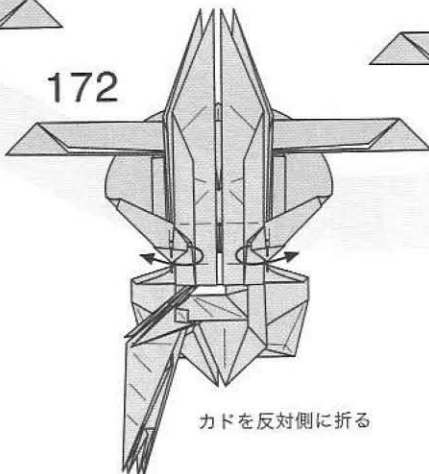

カドを反対側に折る

171

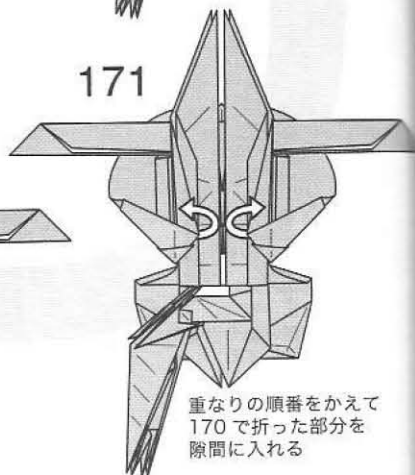

重なるの順番をかえて
170で折った部分を
隙間に入れる

174

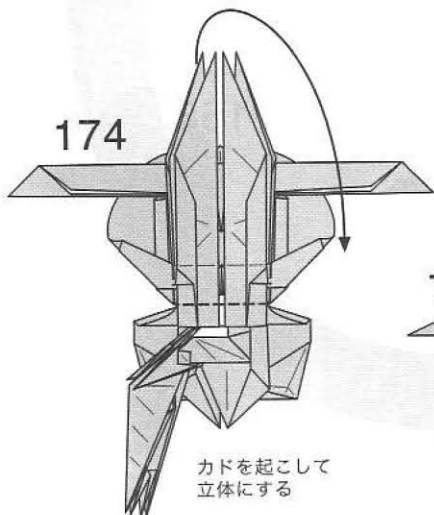

カドを起こして
立体にする

175

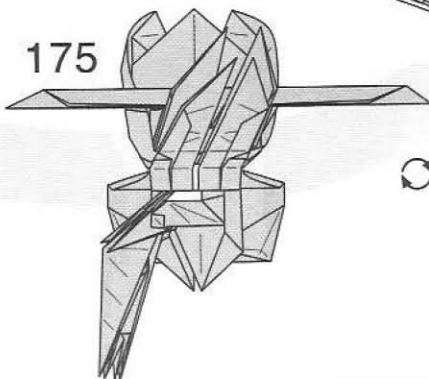

176

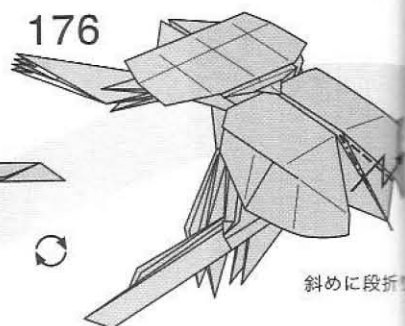

斜めに段折り

185

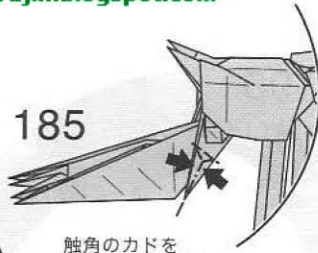

触角のカドをつまむように折る

187

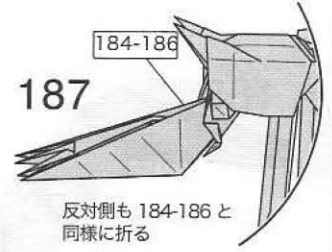

反対側も 184-186 と同様に折る

184

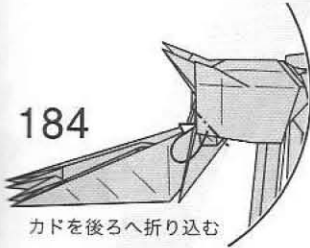

カドを後ろへ折り込む

186

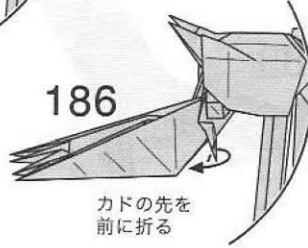

カドの先を前に折る

183

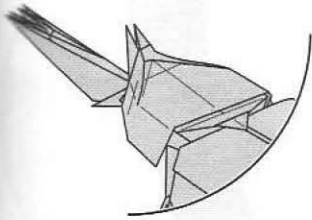

182

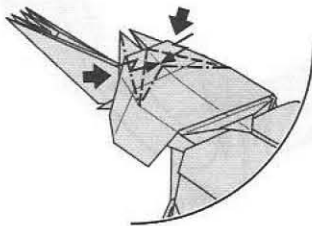

ツノの部分を集めるように段折り

181

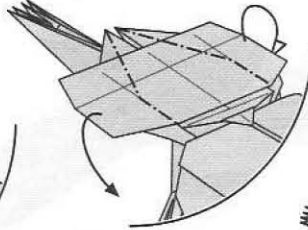

前胸を立体にする

180

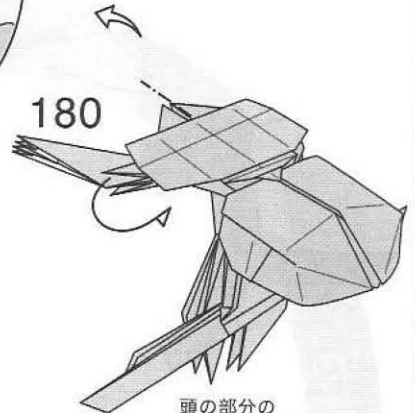

頭の部分のカドを起こすように折る

177

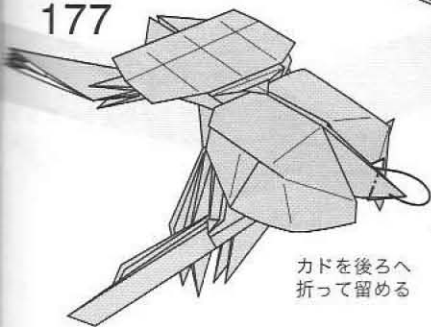

カドを後ろへ折って留める

178

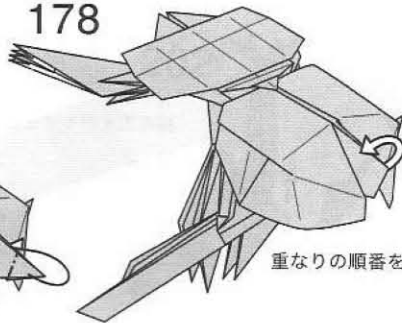

重なるの順番をかえる

179

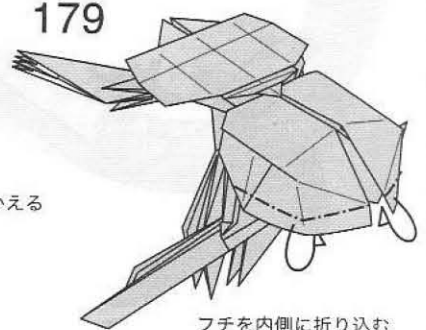

フチを内側に折り込む

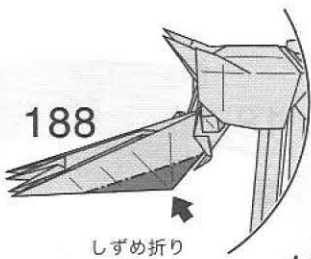

188

しずめ折り

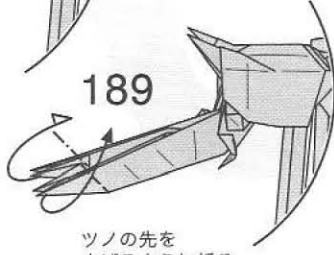

189

ツノの先を
広げるように折る

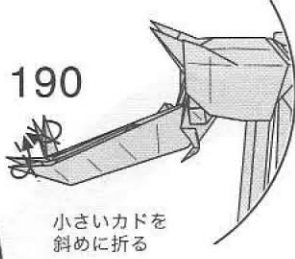

190

小さいカドを
斜めに折る

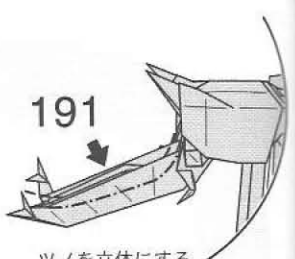

191

ツノを立体にする

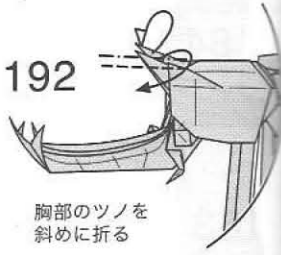

192

胸部のツノを
斜めに折る

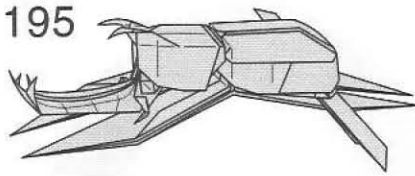

195

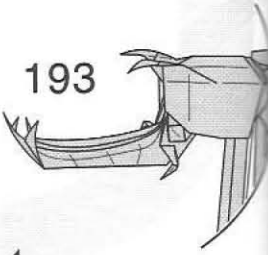

193

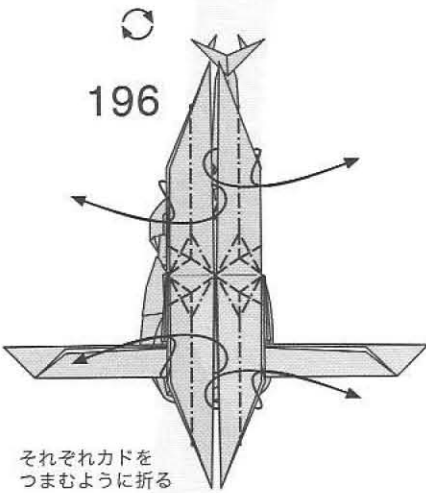

196

それぞれカドを
つまむように折る

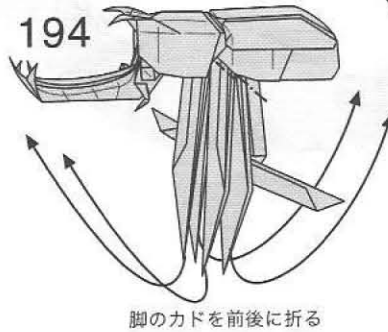

194

脚のカドを前後に折る

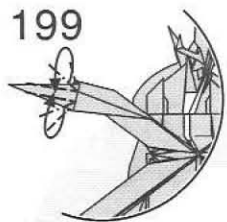

199

脚の先を細くするように折る

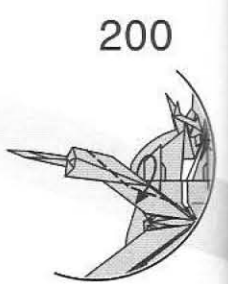

200

脚をつまむように折って
形を整える

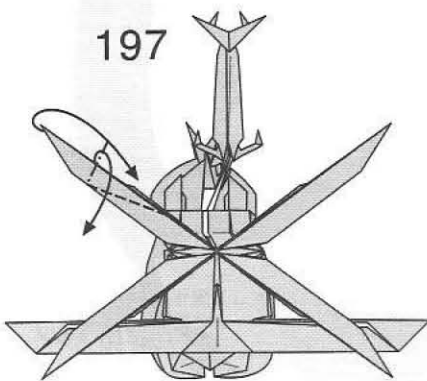

197

手前の紙を斜めに折って
つぶすように折る

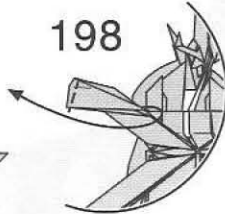

198

カドを外に折る

208

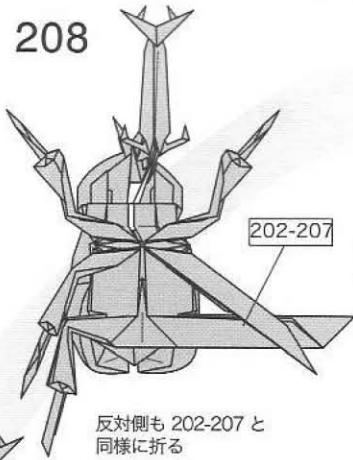

反対側も 202-207 と同様に折る

207

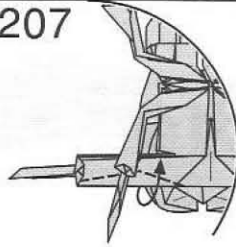

脚をつまむように折って形を整える

206

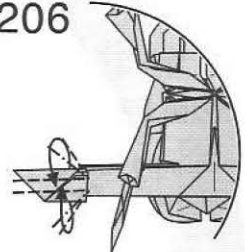

脚の先を細くするように折る

209

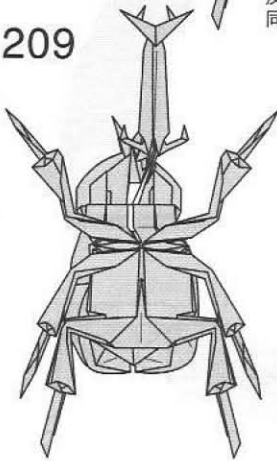

210

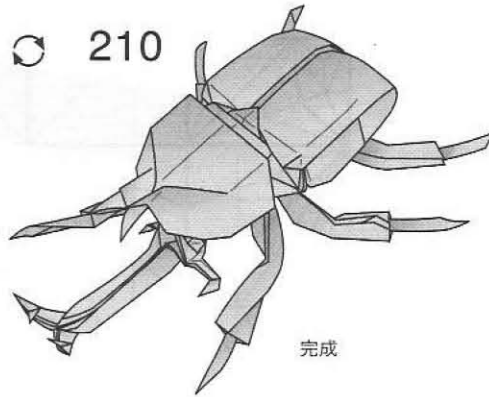

完成

205

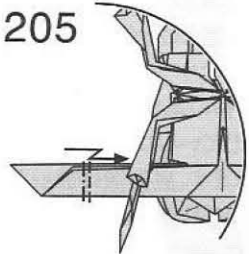

段折り

201

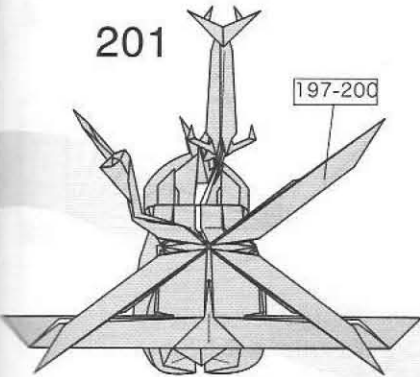

反対側も 197-200 と同様に折る

202

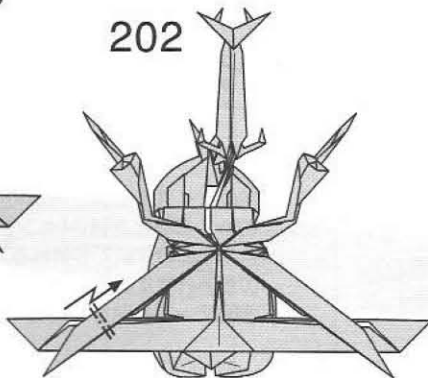

段折り

204

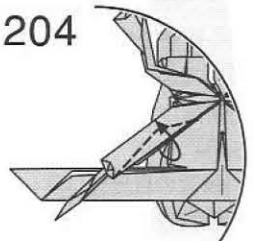

脚をつまむように折って形を整える

203

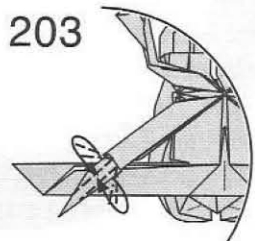

脚の先を細くするように折る

ミヤマクワガタ

Lucanus stag beetle

創作：北條高史

折り図：おりがみはうす

Design: Hojyo Takashi

Diagrams: Origamihouse

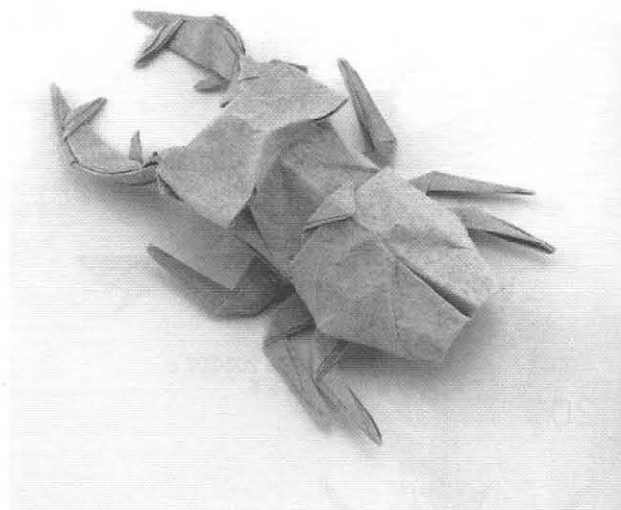

[ミヤマクワガタ]

展開図のごとく、クワガタを折り出すためとしてはオーソドックスなカドの配置を用いています。最初の基準となる折りの比率を辺の3分の1としているので、比較的大きい完成形が得られます。展開図は設計的に見えますが、実際は手作業によって解決した部分がほとんどです。ミヤマクワガタに特徴的な頭部の立体形状を容易に表現できるところが本作品のセールスポイントでしょうか。胸部から小楯板にかけての折り出し（工程 118～129）は立体的な作業なので少々難しいですが、展開図を理解できる方はこれを工程図とあわせて構造を確認していただくとさらに分かり易くなるでしょう。

最近の自分には珍しい、題材に対する作者独自の解釈とか奇妙な作品コンセプトなどをもたないひたすら純粹真面目リアル路線の作品になりました。…と自分では思っていたのですが、目黒俊幸氏にこの作品を解析していただいたところ技術的にもおもしろいポイントがいくつか見つかったそうです。

なお、工程 176 で折った脚の無駄部分と工程 196 で折り込んだキバの無駄部分を引き出して寄せ合うことにより、作例写真のような触角（もどき？）を折り出すことが可能です。腕に自身のある方は試してみてください。

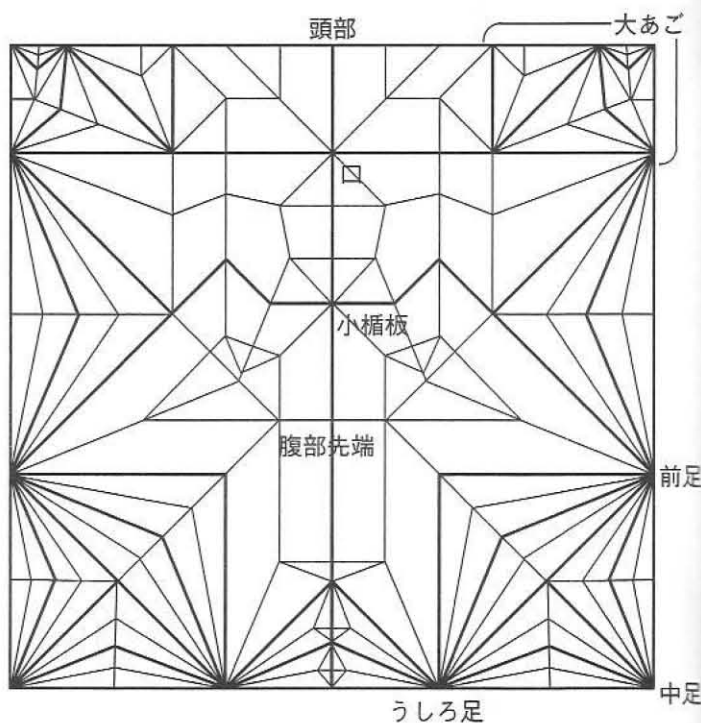

完成サイズ：全長が用紙の辺の約40%になります。初めて折るときは24センチ以上の用紙を使うとよい。少々厚めの洋紙でも折れる。ホイル紙の場合は小楯板周辺が割れやすいので、用紙の正中線のところに裏側から透明テープを貼って補強しておくこと。

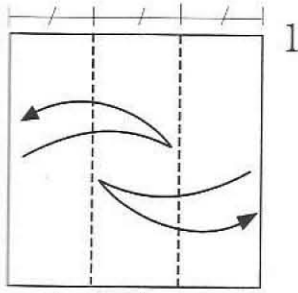

1/3の幅に折り筋をつける

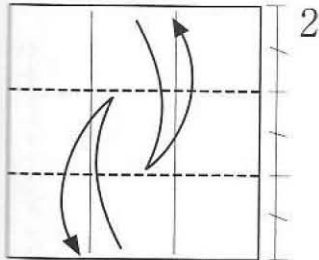

1/3の幅に折り筋をつける

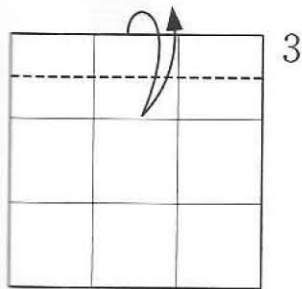

折り筋に合わせて折り筋をつける



折り筋に合わせて折り筋をつける

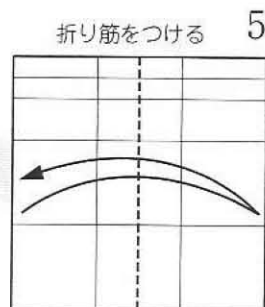

折り筋をつける

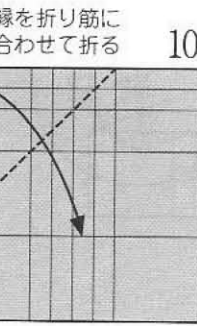

縁を折り筋に合わせて折る

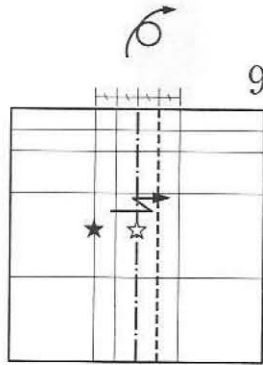

反対側も同じようにして折り筋をつける

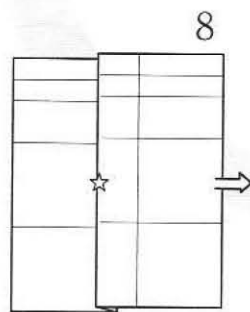

戻す

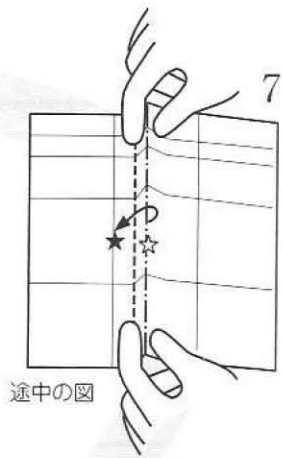

途中の図

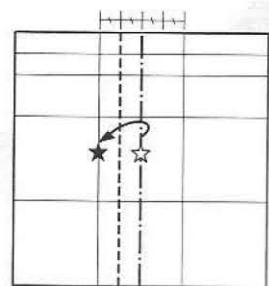

☆の折り筋をつまんで
★の折り筋に合わせて折る

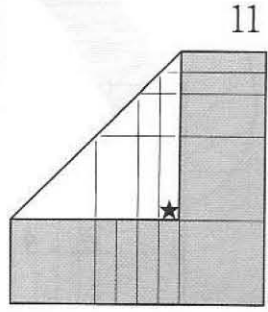

11

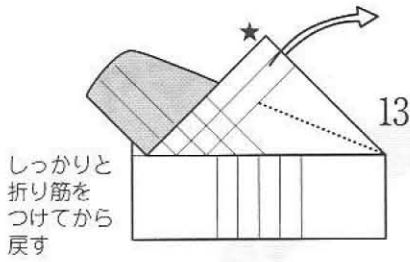

しっかりと
折り筋を
つけてから
戻す

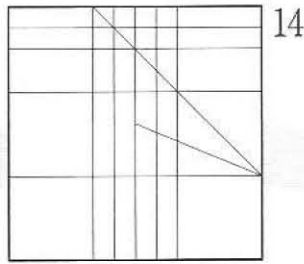

反対側も7~13と
同じ

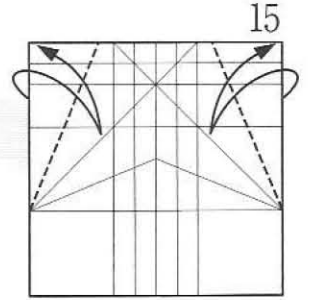

折り筋に合わせて
折り筋をつける

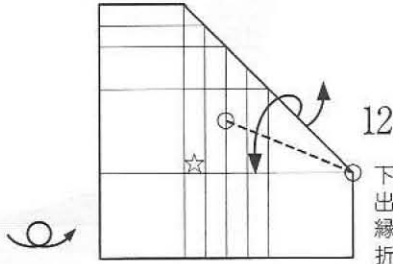

下のカド(★)を上
に出すようにしながら
縁を折り筋に合わせて
折る



三角に折る

縁を折り筋に
合わせて
折り筋をつける

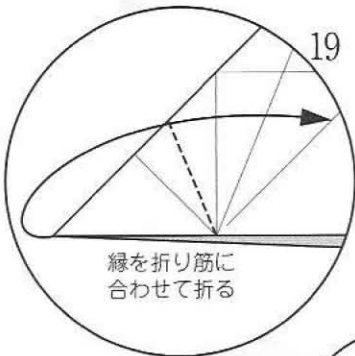
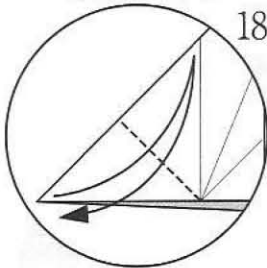

縁を折り筋に
合わせて折る

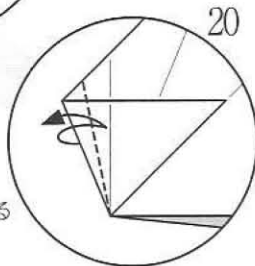

縁を折り筋に
合わせて
折り筋をつける

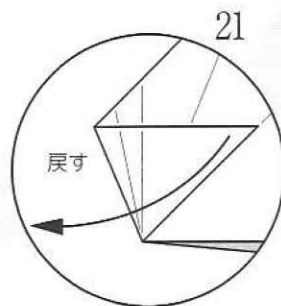

戻す

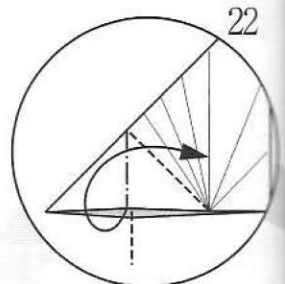

内側をひろげて
つぶすように折る

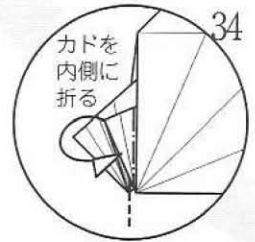
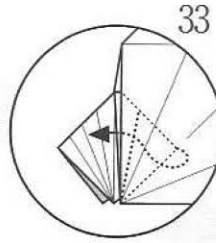
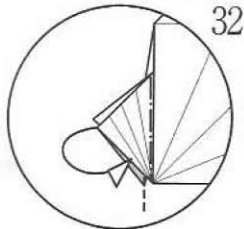
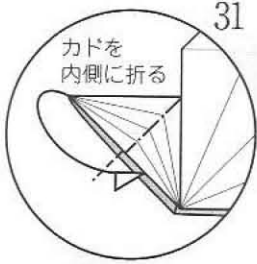

Japão Burajirujin
www.japaoburajirujin.blogspot.com

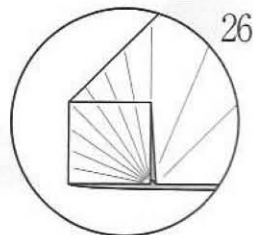
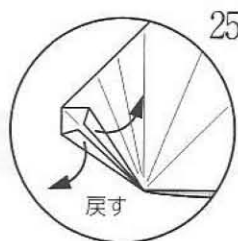
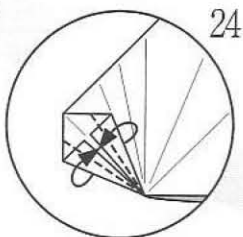
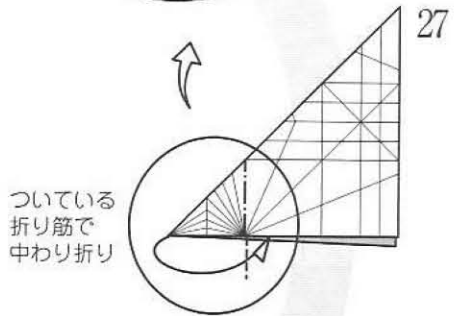
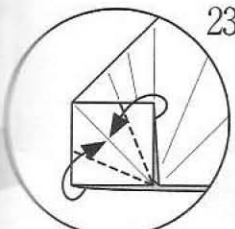
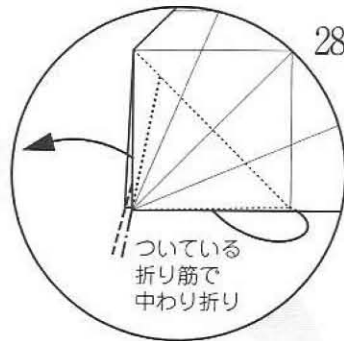
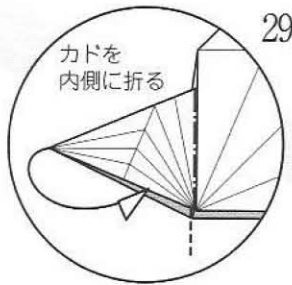
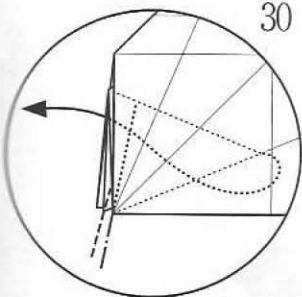

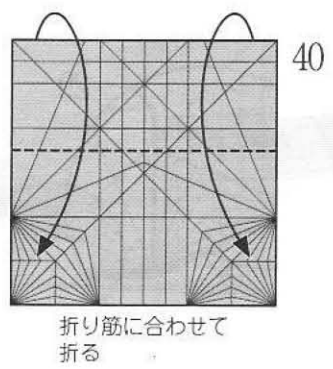
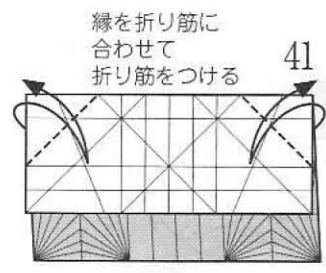
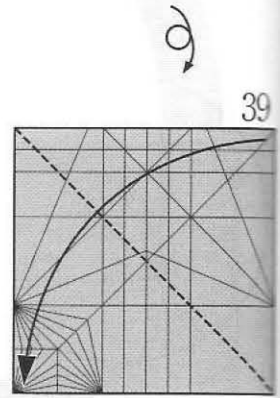
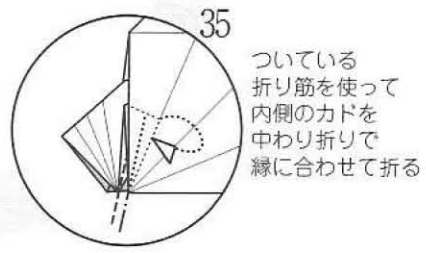
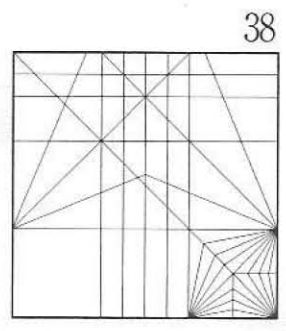
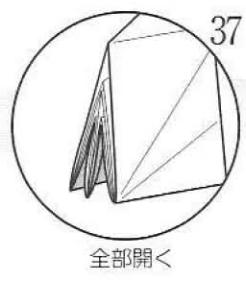
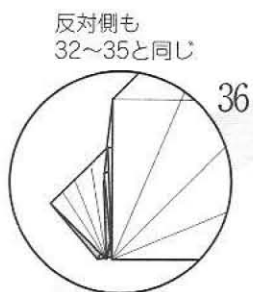

反対側も16~38と
同じ

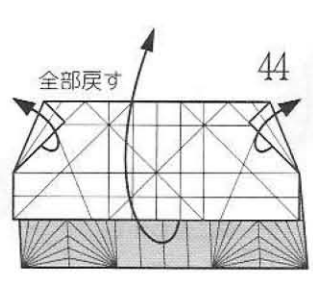
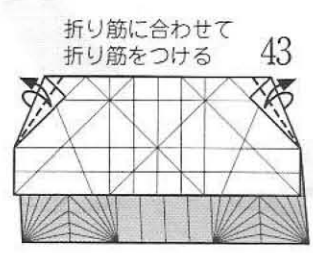
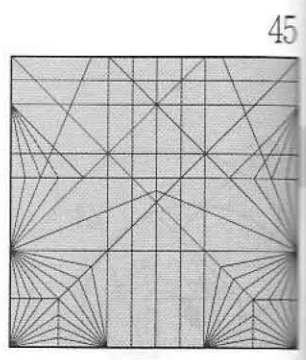
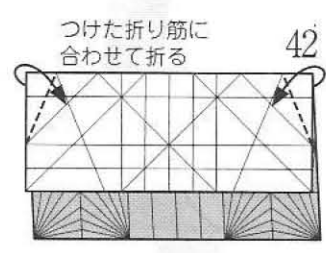

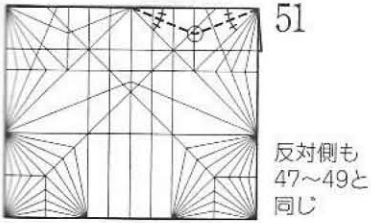
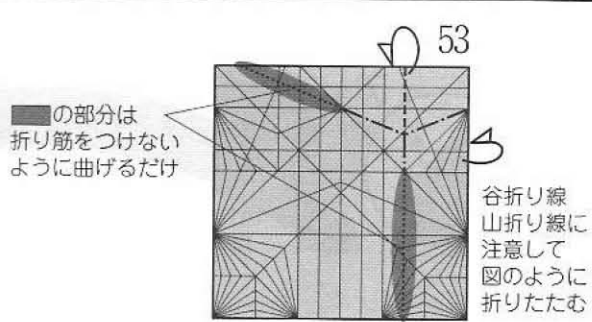
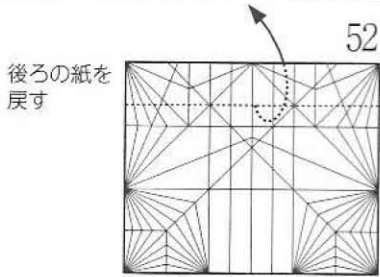

Japão Burajirujin
www.japaoburajirujin.blogspot.com

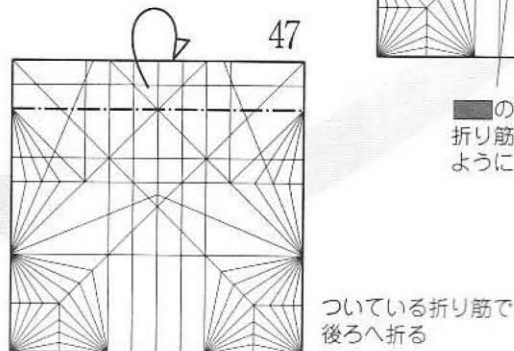
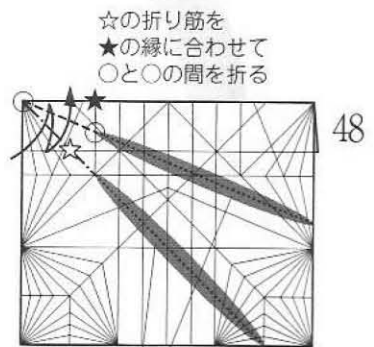
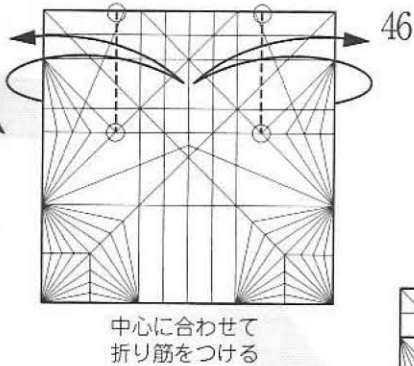
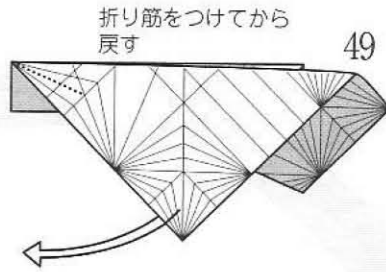
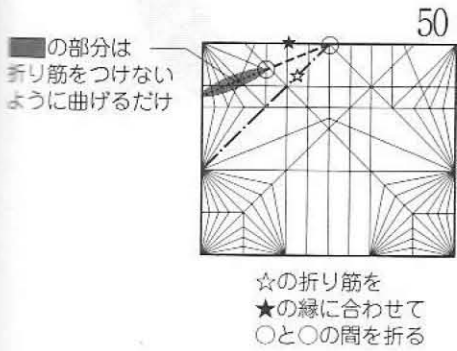
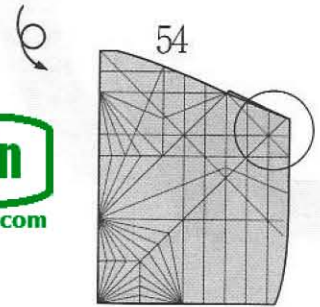

折り筋をつけてから戻す

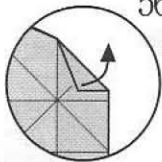

56

53の状態に戻す

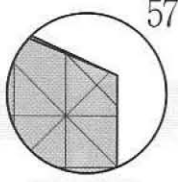

57

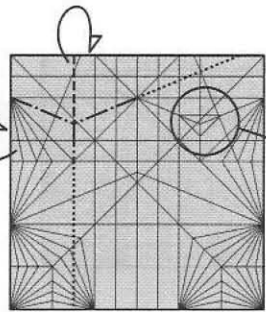

つけた折り筋はこの折り筋からはみ出す

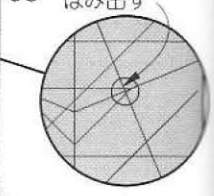

反対側も 53~56と同じ

55

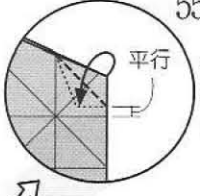

縁が折り筋に平行になるように折る

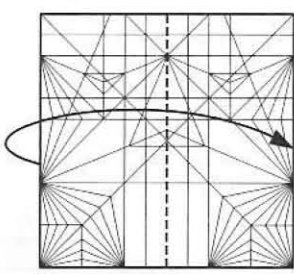

61

半分に折る

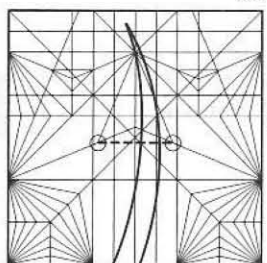

60

折り筋の交点で折り筋をつける

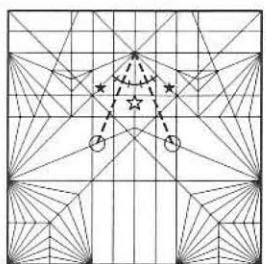

59

47~48の要領で ☆と★の折り筋を合わせて折り筋をつける

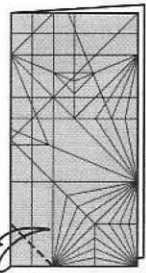

62

縁を折り筋に合わせて折り筋をつける

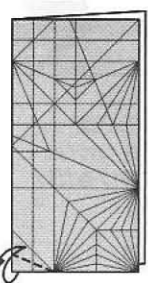

63

つけた折り筋に合わせて折り筋をつける

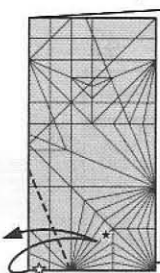

64

☆の縁を ★の折り筋に合わせて折る

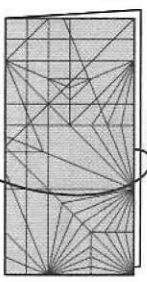

65

戻す

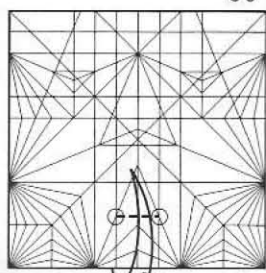

66

折り筋の交点を結ぶ線で折り筋をつける

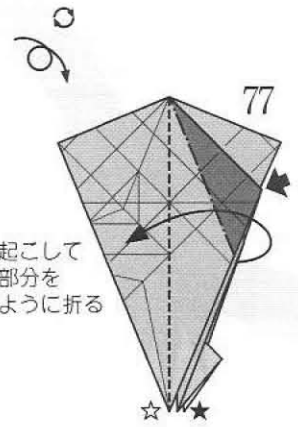
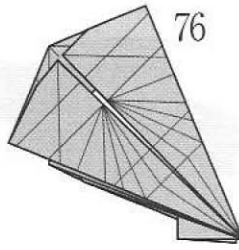
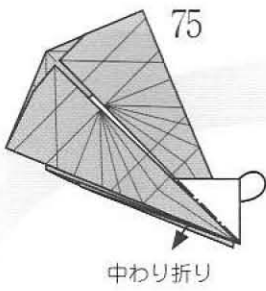
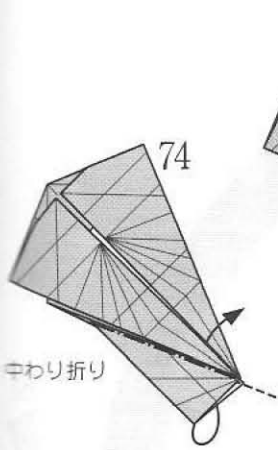

Japão Burajirujin

www.japaoburajirujin.blogspot.com

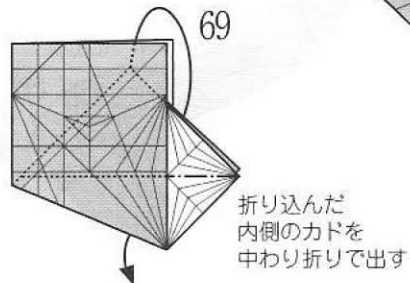
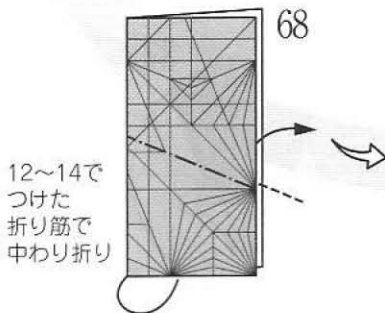
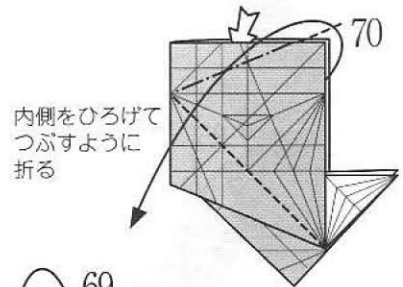
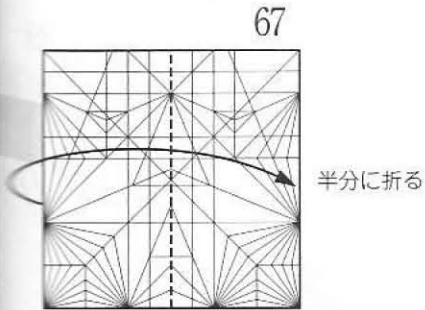
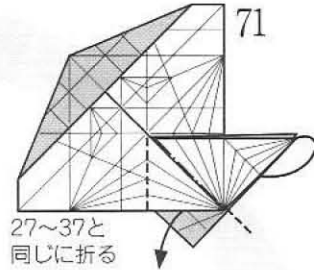
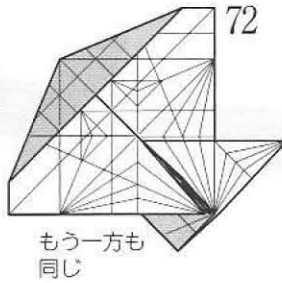
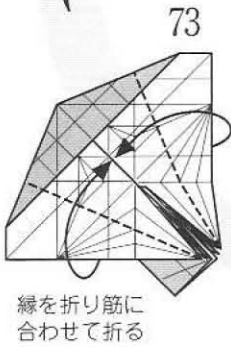

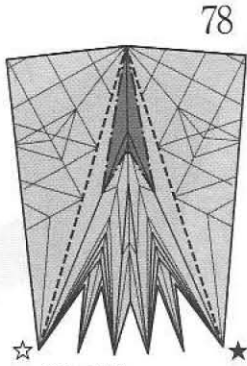

途中の図
 ついている折り筋で
 ■の部分をつぶす
 ように折る

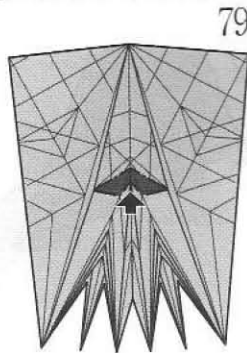

途中の図
 ■の部分
 を内側に押し込む

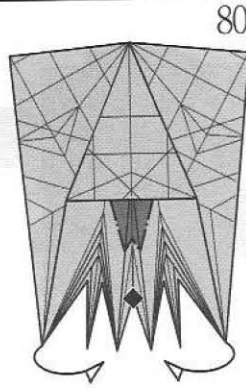

途中の図
 ■の部分
 を内側から
 押し出して
 平らにする

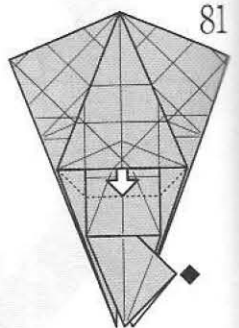

内側から紙を
 押し出す

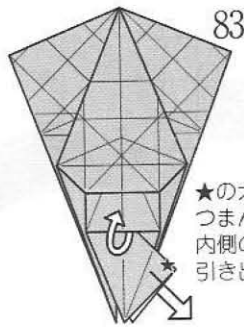
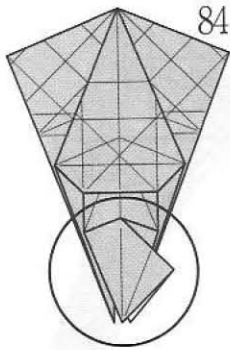

★のカドを
 つまんで
 内側の紙を
 引き出す

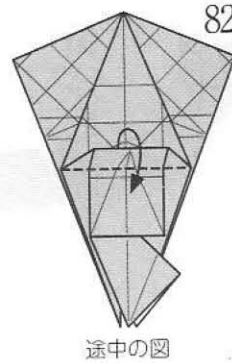

途中の図

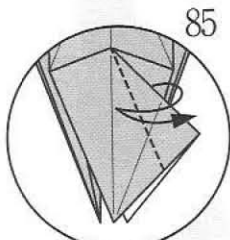

折り筋をつける

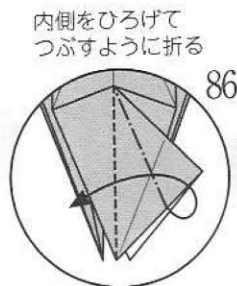

内側をひろげて
 つぶすように折る

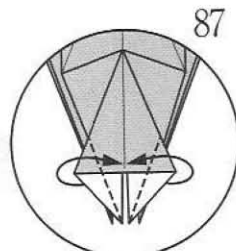

折り筋に合わせて折る

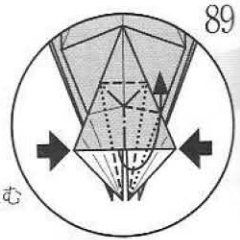

内側をひろげて
 ついている
 折り筋で図の
 ように折りたたむ

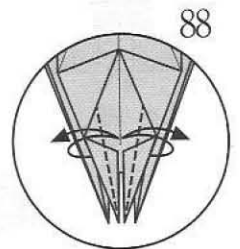

折り筋をつけてから
 87に戻す

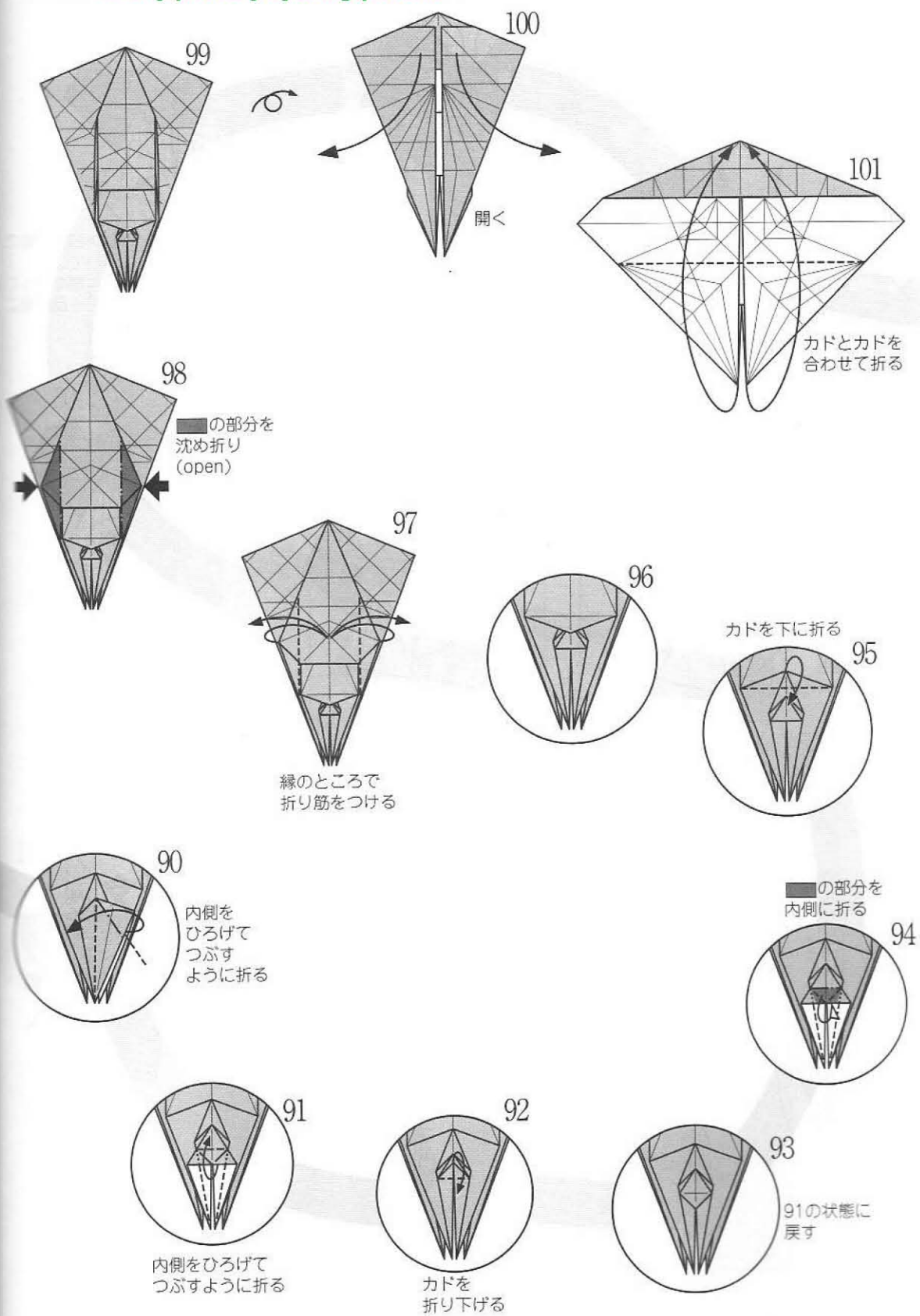

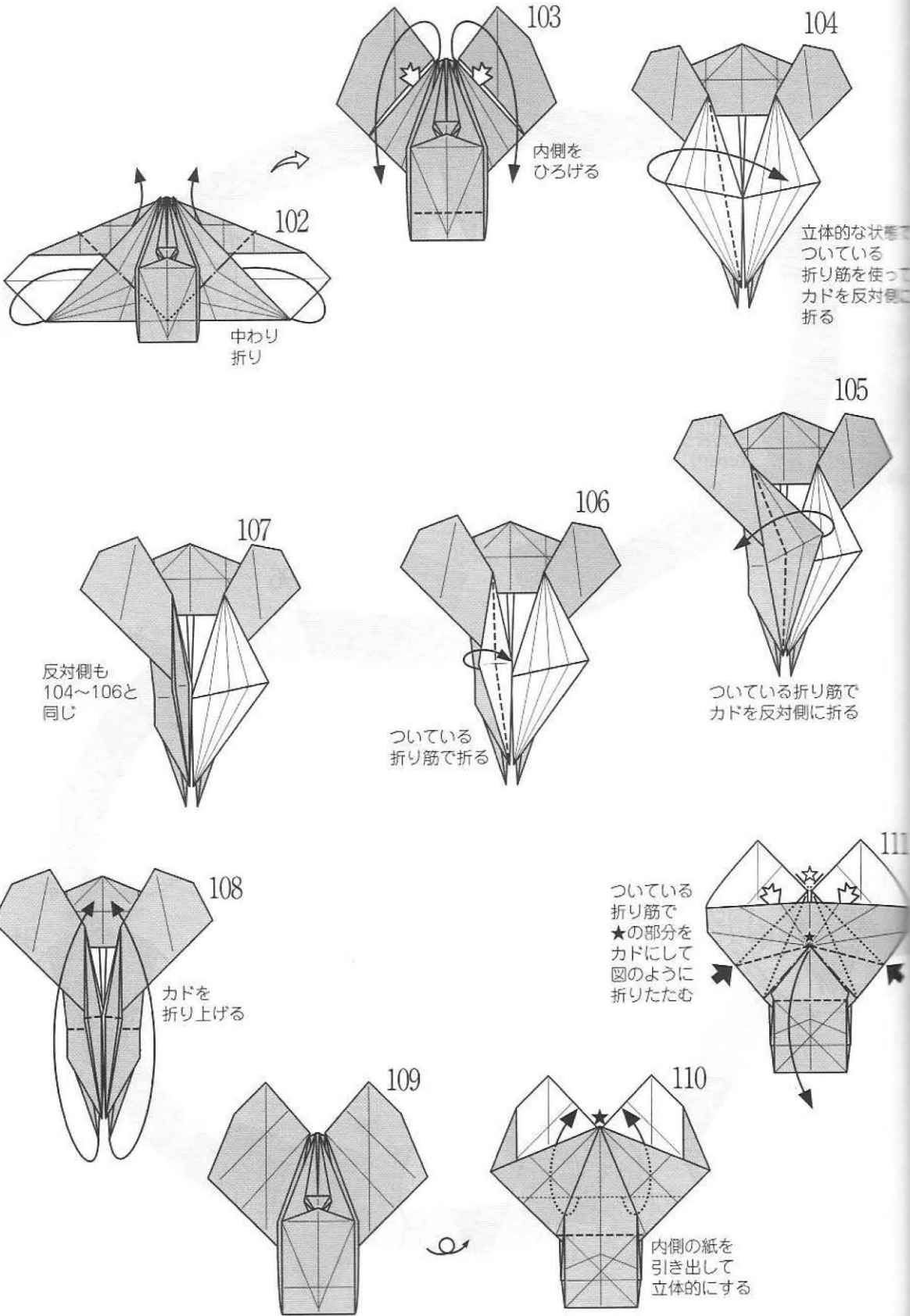

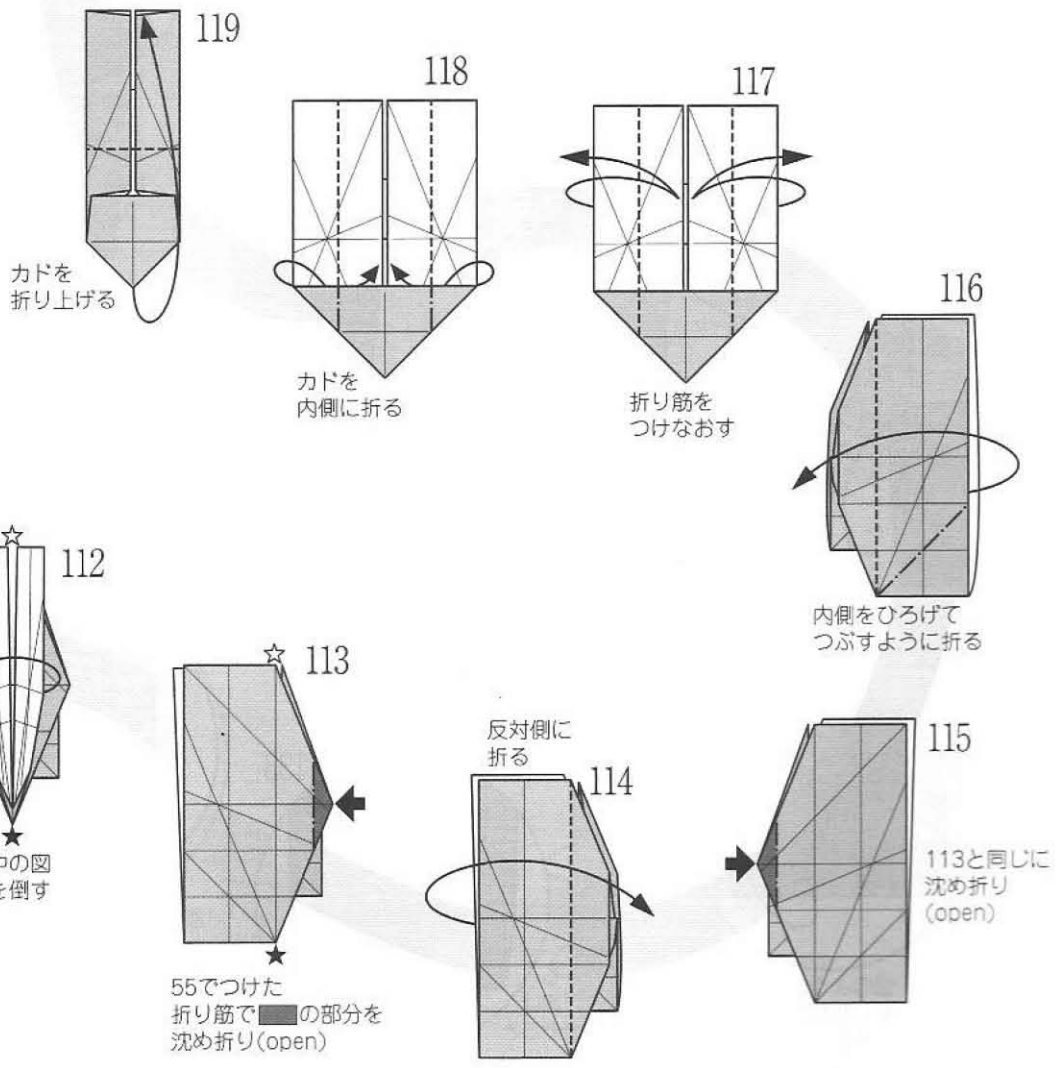
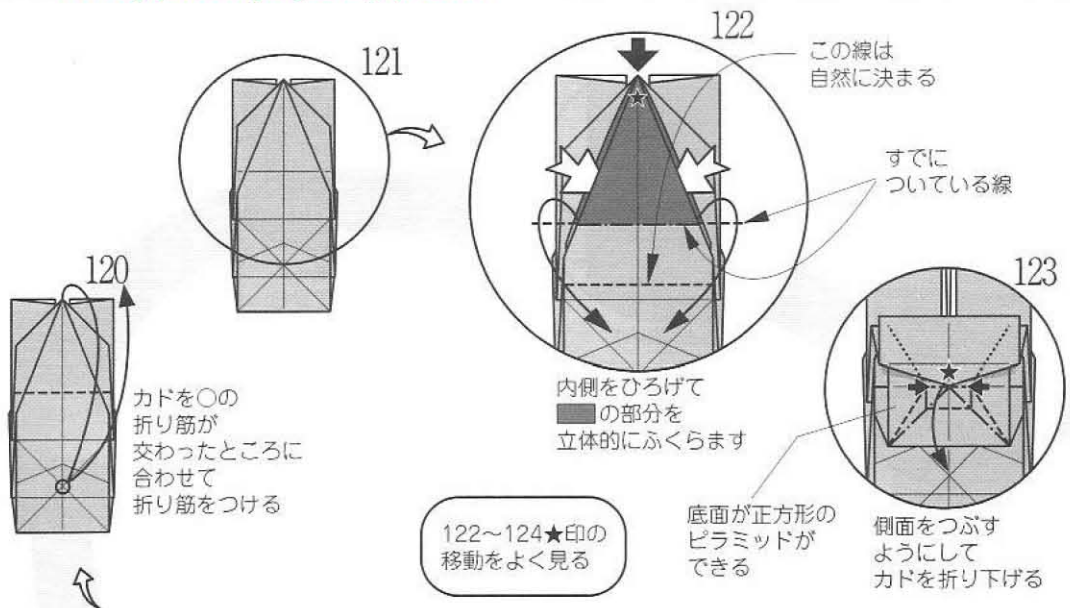

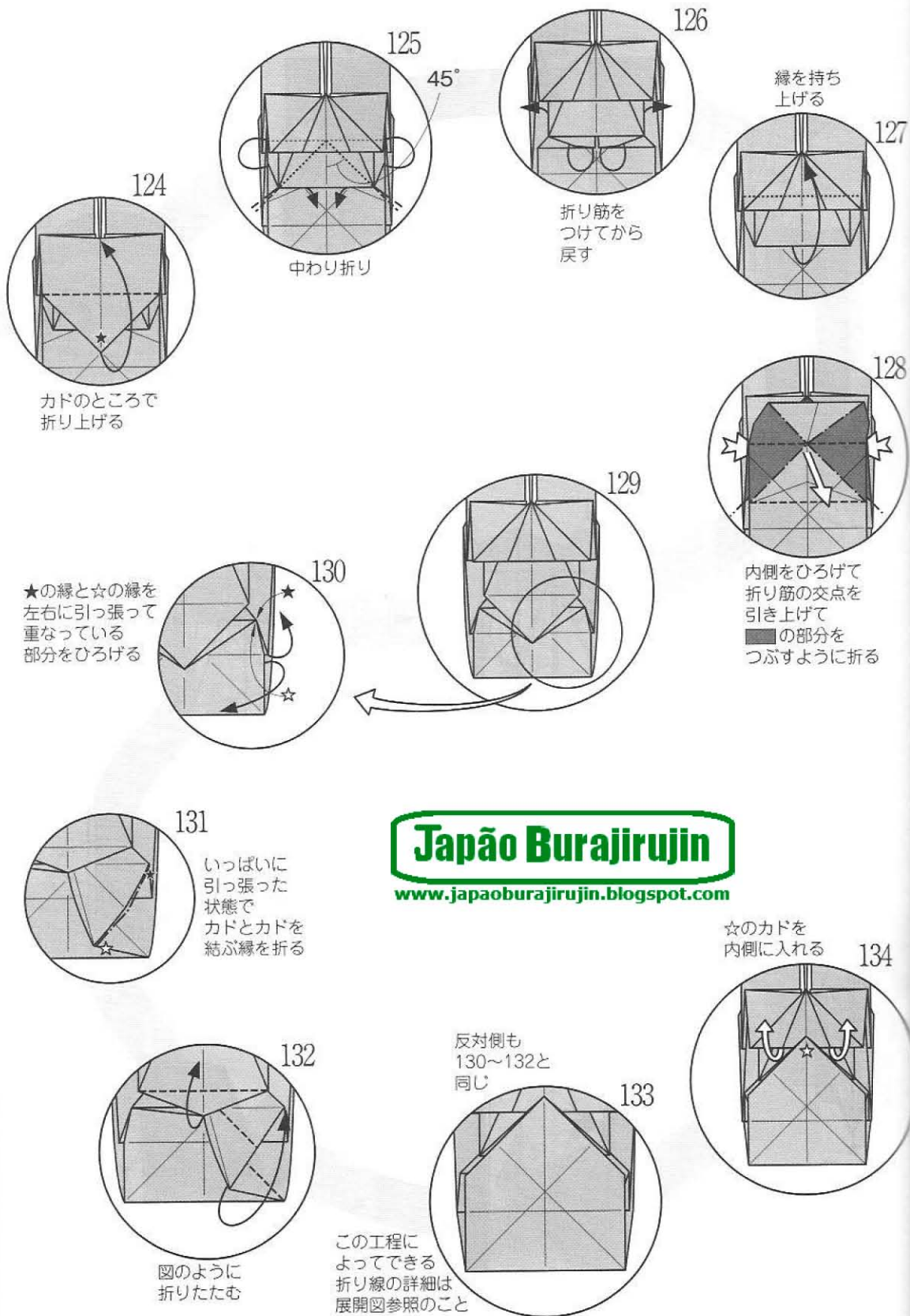

Japão Burajirujin
www.japaoburajirujin.blogspot.com

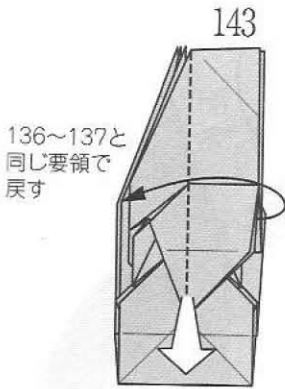

136~137と
同じ要領で
戻す

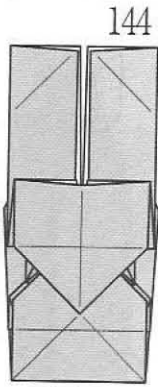

144
反対側も
136~143と
同じ

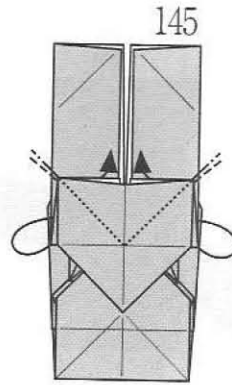

145
中わり折り

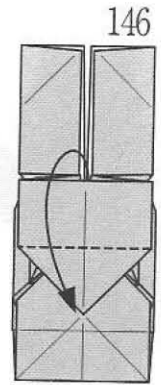

146
縁を下に折る

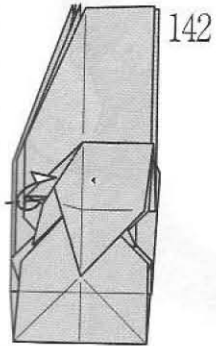

142
縁を折り上げて
たたむ

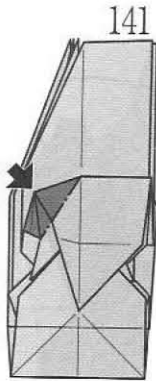

141
途中の図
三角錐状に
広げてから
押し込む

■の部分をしめ折り
次図参照openとclosedが
組み合わさっているので注意!

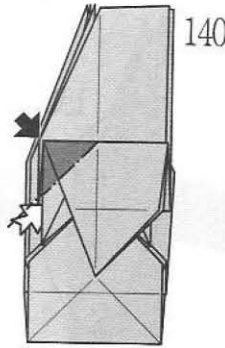

140

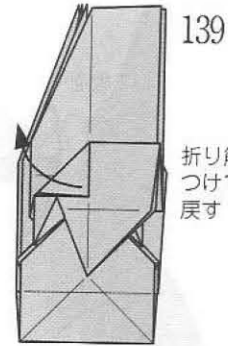

139
折り筋を
つけてから
戻す

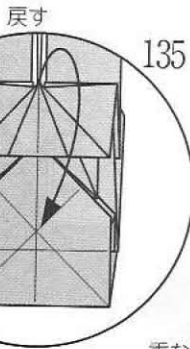

135
戻す

重なりを
くずさない
ように
カドを斜めに
引き上げる

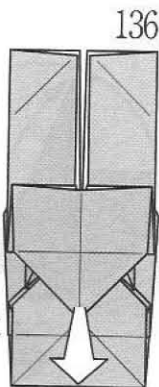

136

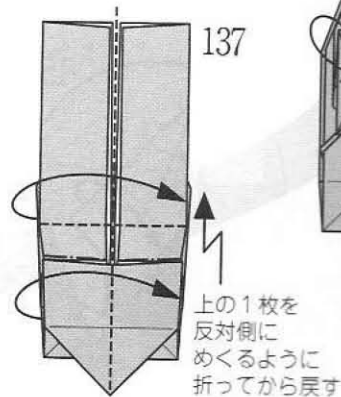

137

上の1枚を
反対側に
めくるように
折ってから戻す

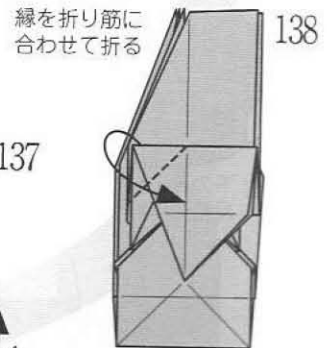

138
縁を折り筋に
合わせて折る

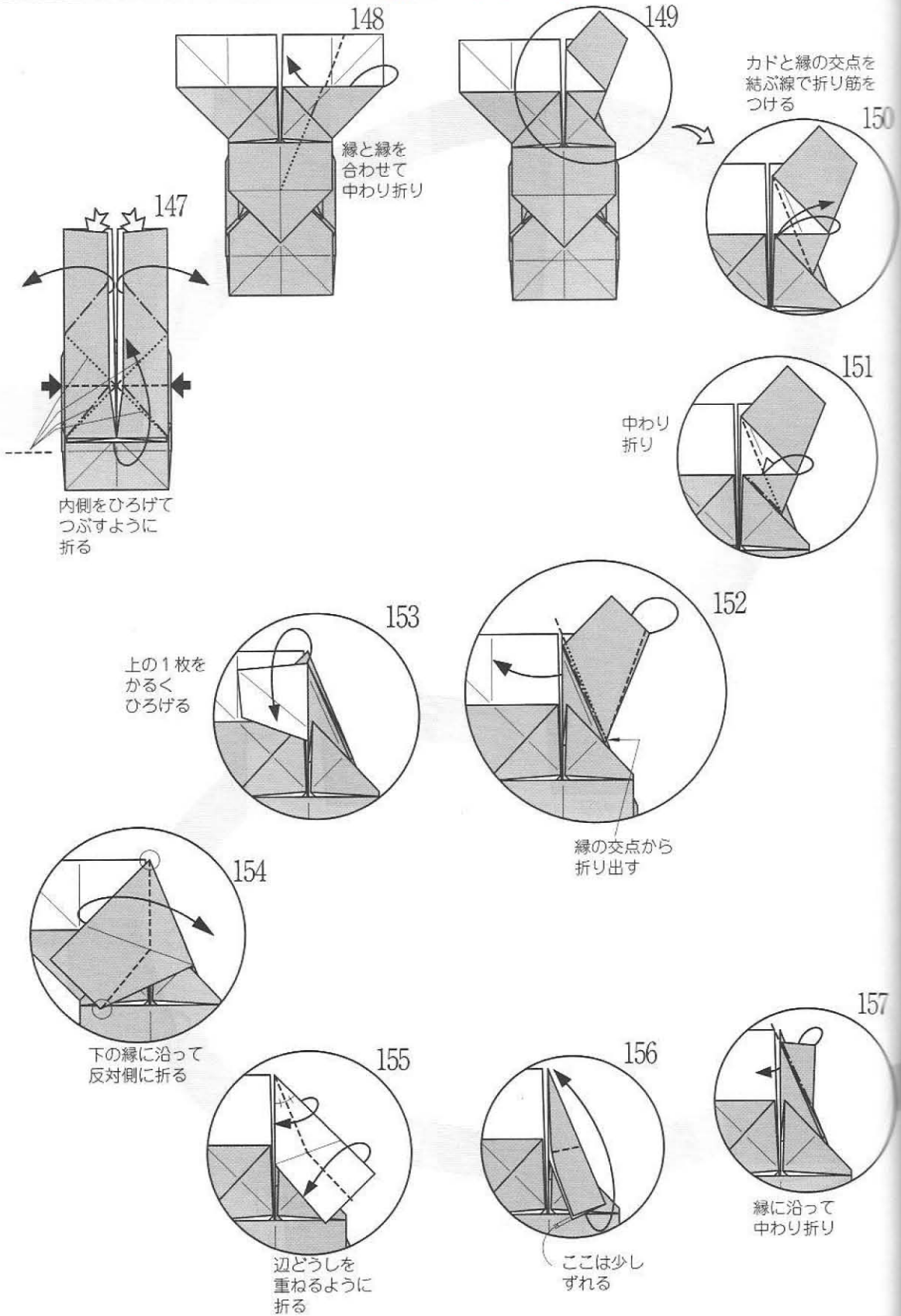

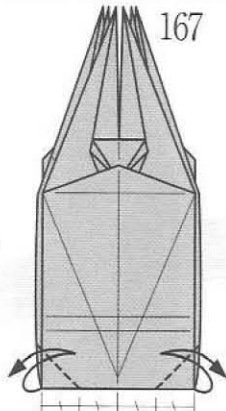
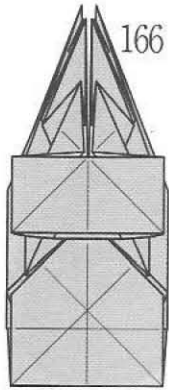

折り筋をつける

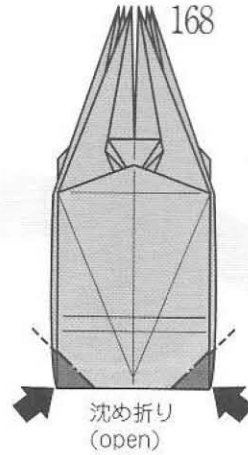

沈め折り
(open)

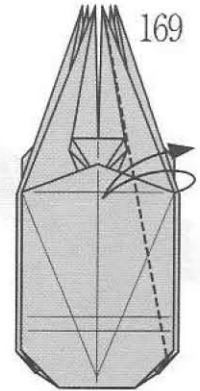

縁に沿って折り筋を
つける

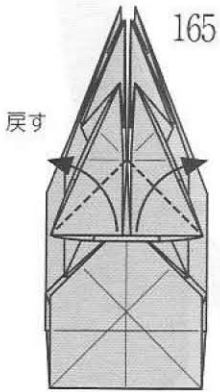

戻す

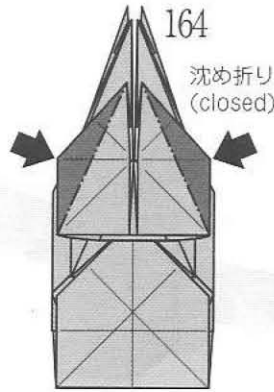

沈め折り
(closed)

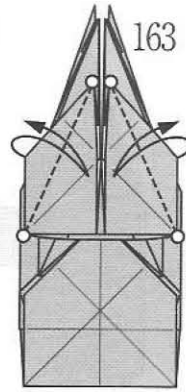

○と○のカドを
結ぶ線で
折り筋をつける

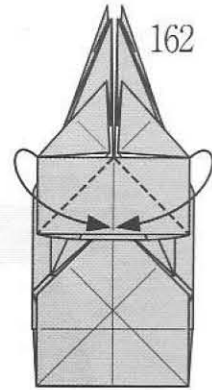

縁と縁を
合わせて折る

縁に沿って
中わり折り

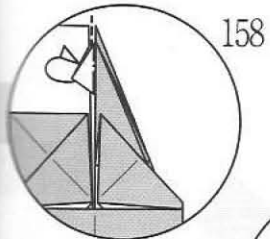

158

縁と縁を
合わせて
カドを
内側に折る

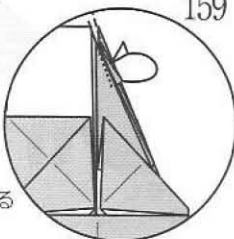

159

反対側も
148~159と
同じ

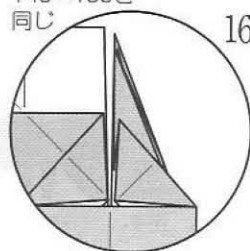

160

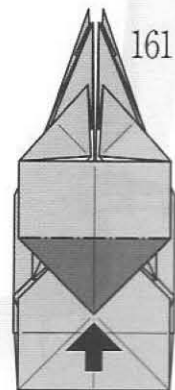

■の部分
を沈め折り
(closed)

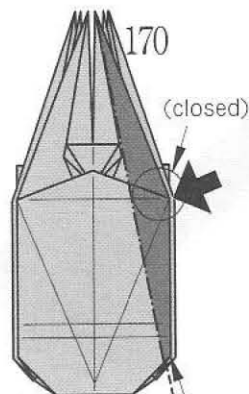

沈め折り
(open
つぶすように)

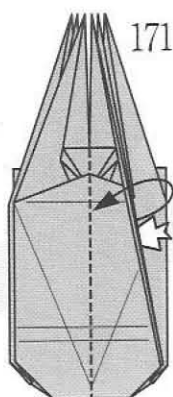

ひろくなっている
手前の重なりまで
まとめて持ち上げる

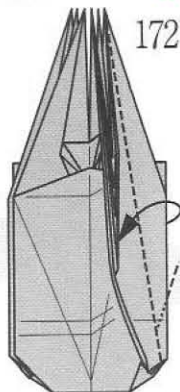

下の層の縁(中心線)に
沿って、下端は内側を
ひろげてつぶすように
折る

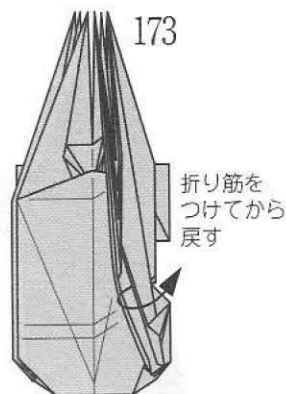

折り筋を
つけてから
戻す

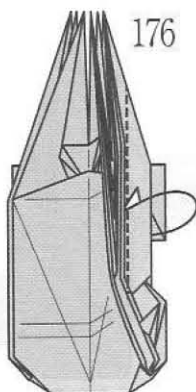

縁をすき間に
折り込む

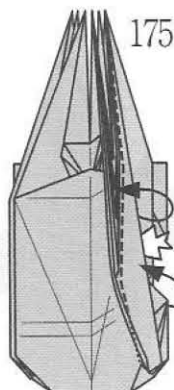

沈め折りした紙を
他と同じように
めくって持ち上げる

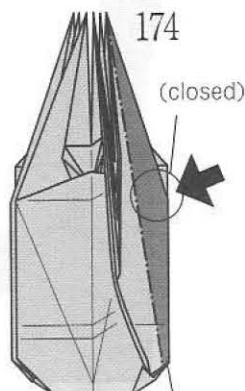

沈め折り (open)

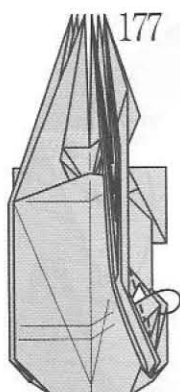

カドをすき間に
折り込む

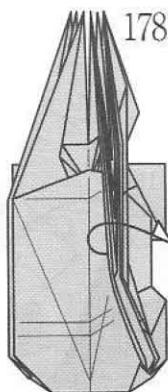

戻す

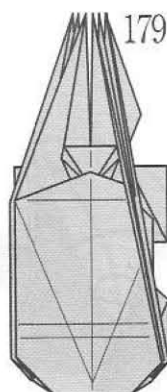

反対側も
169~178と
同じ

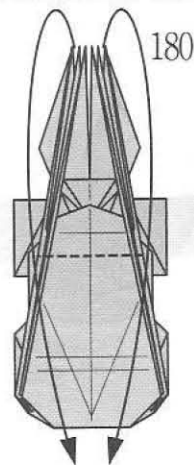

次の図のように
足を開く位置が
裏面の縁と折り筋の
交点にくるように折る

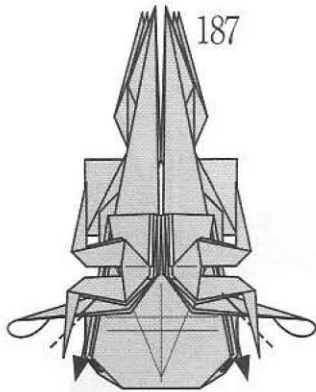

187

中わり折り

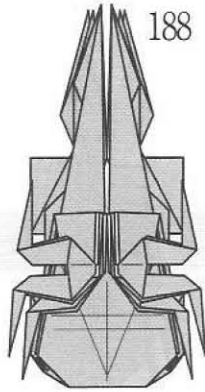

188

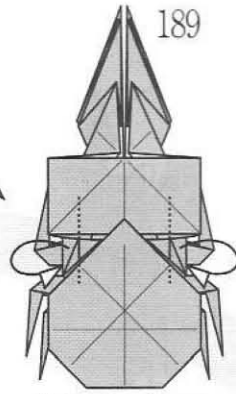

189

縁を後ろへ折って
すき間に差し込む

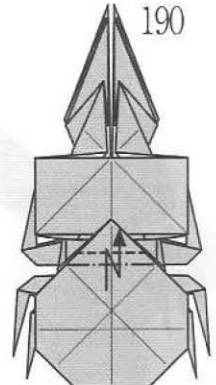

190

内側に差し込む
ように段折り

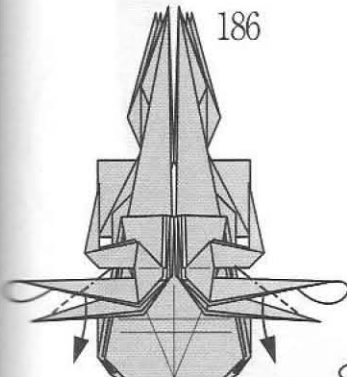

186

中わり折り

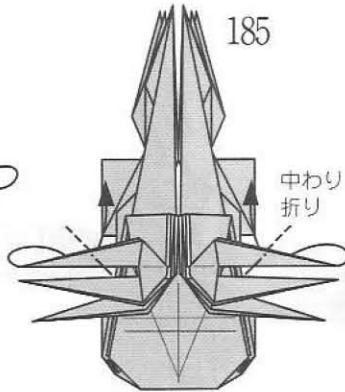

185

中わり
折り

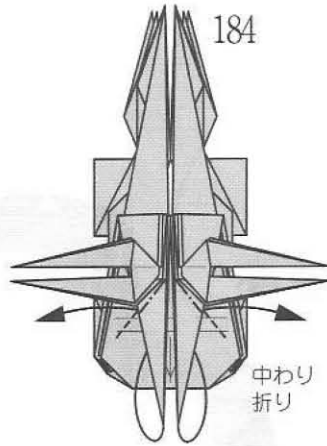

184

中わり
折り

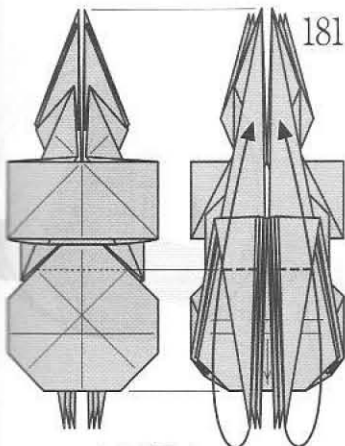

181

カドが開く
ところで折る

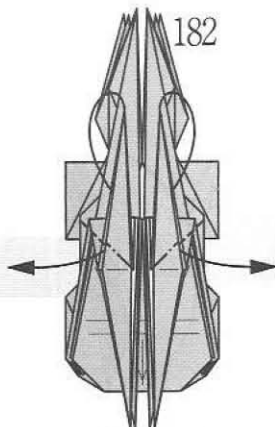

182

中わり折り

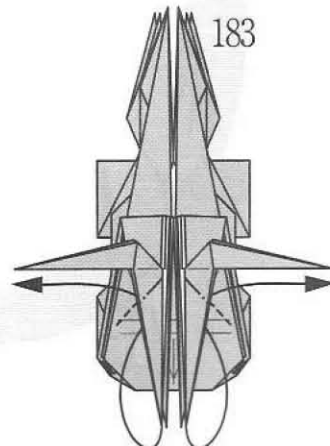

183

中わり折り

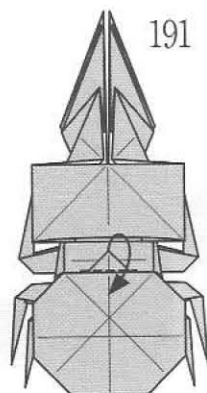

191

縁のところで折る

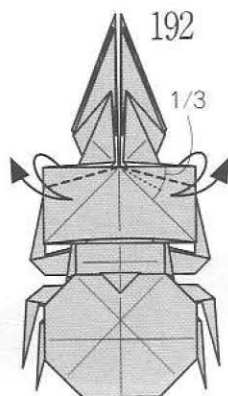

192

1/3

1/3の角度で折り筋をつける

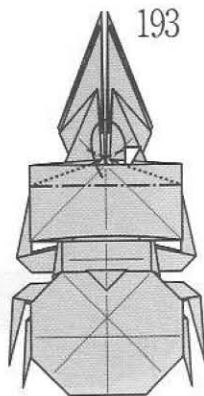

193

つけた折り筋を使って縁を内側に折る

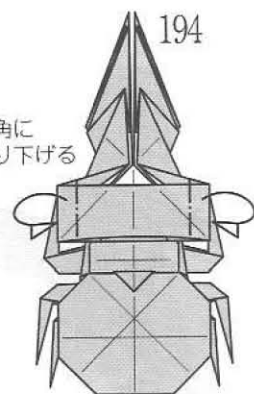

194

直角に折り下げる

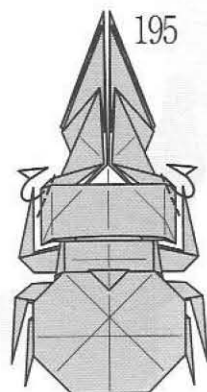

195

カドを起こして平らにする

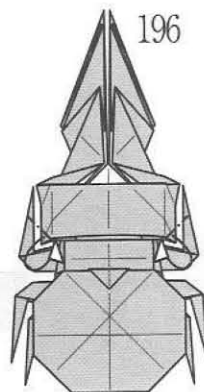

196

カドを内側に折る

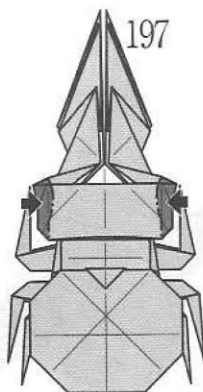

197

■の部分にくぼみをつけるようにして形を整える

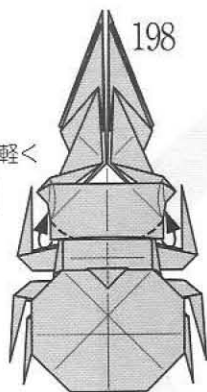

198

カドを軽くつまみ上げる

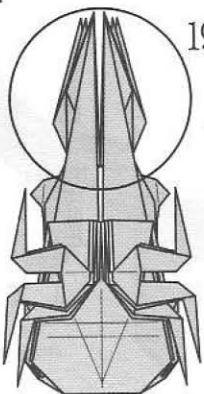

199

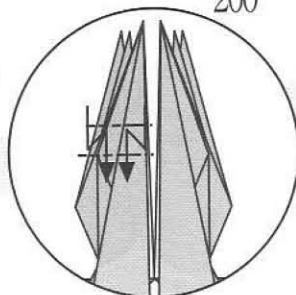

200

内側に段折り

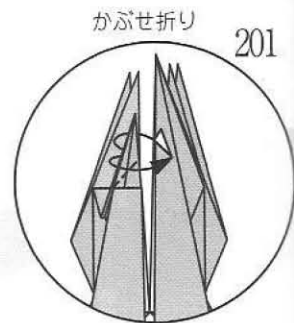

201

かぶせ折り

カドを開くところで
下に折る

208

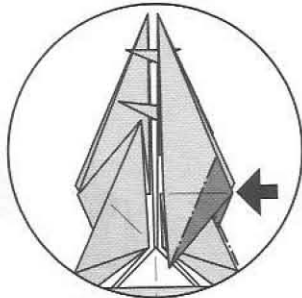
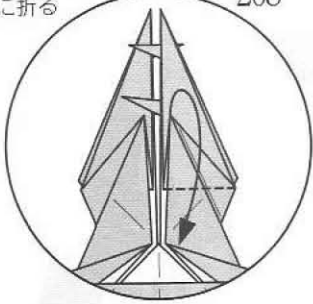

■の部分
沈め折り(open)

カドを内側に折る

210

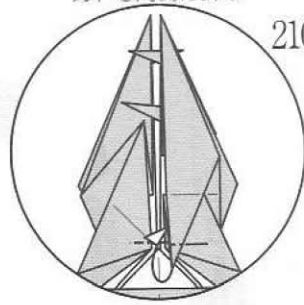

207

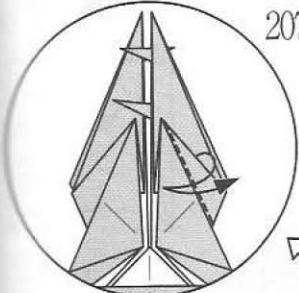

縁に沿って折り筋を
つける

206

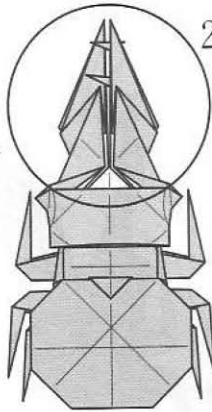

211

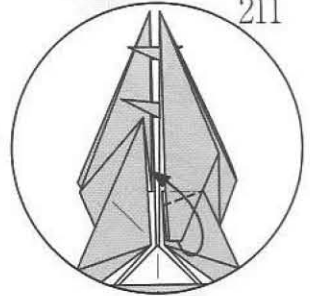

斜めに折る

212

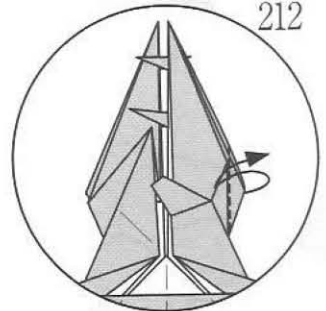

縁にそって
折り筋をつける

205

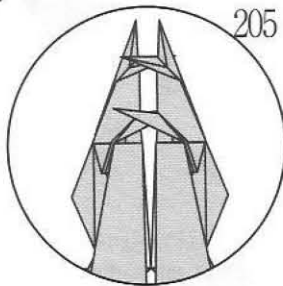

斜めに折る

202

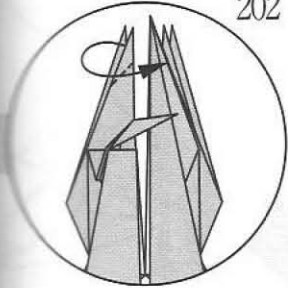

203

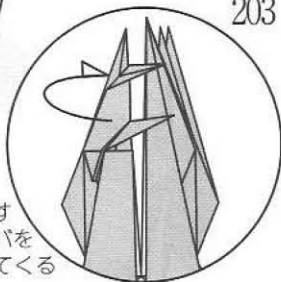

カドを
下にまわす
右側のキバを
上にもってくる

204

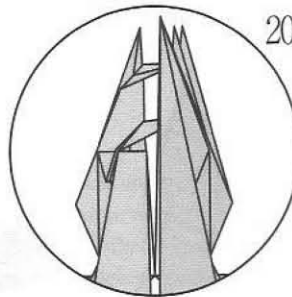

反対側も
200~202と
同じ

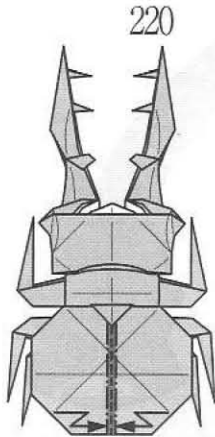

220
■の部分をつまむようにして折る

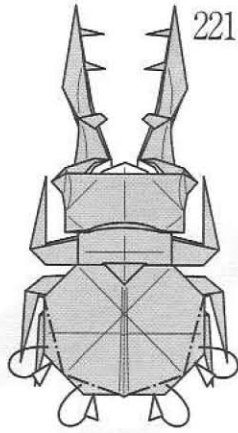

221
カドを後ろへ折る

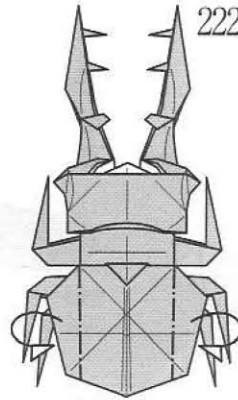

222
カドを後ろへ軽く曲げるように折る

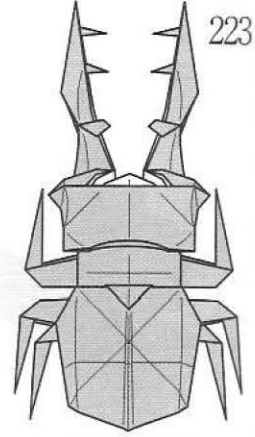

223
できあがり

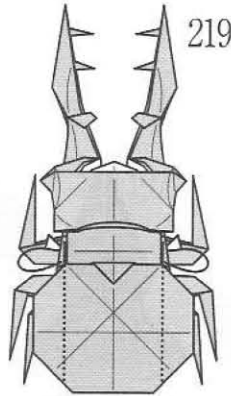

219
横に出ている縁を後ろに折り形を整える

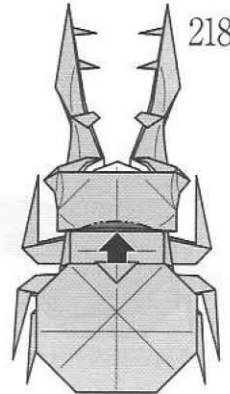

218
■の部分をつぶして少し押し込む



217
カドを軽く後ろへ折る

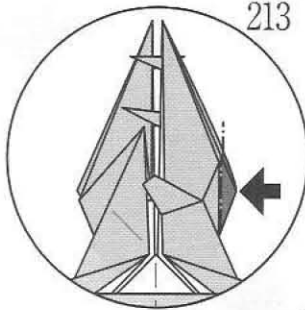

213
■の部分をしめ折り

つまんで細くしながら顎をひらくように折る

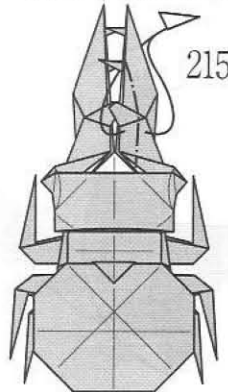

215

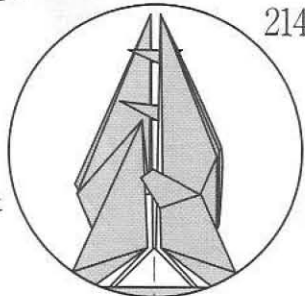

214
反対側も207~213と同じ

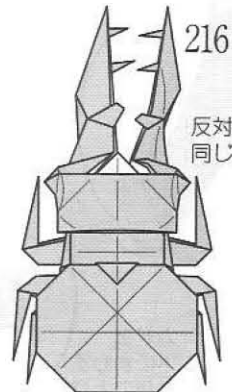

216

反対側も同じ

BAMBOO STAR

HERMAN VAN GOUBERGEN

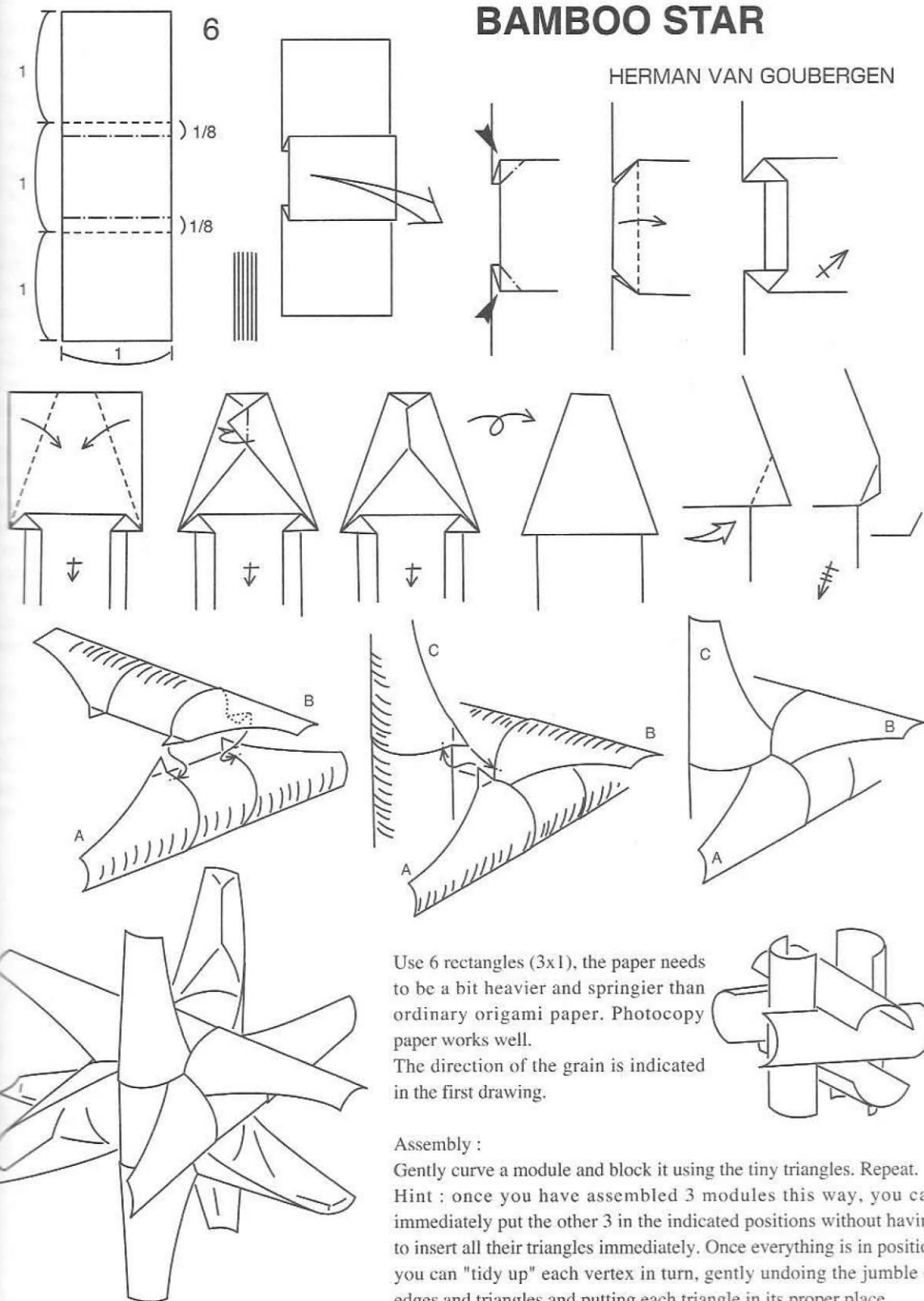

Use 6 rectangles (3x1), the paper needs to be a bit heavier and springier than ordinary origami paper. Photocopy paper works well. The direction of the grain is indicated in the first drawing.

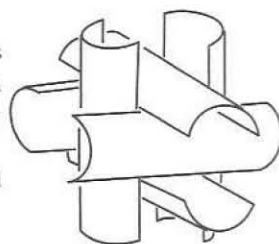

Assembly :

Gently curve a module and block it using the tiny triangles. Repeat. Hint : once you have assembled 3 modules this way, you can immediately put the other 3 in the indicated positions without having to insert all their triangles immediately. Once everything is in position you can "tidy up" each vertex in turn, gently undoing the jumble of edges and triangles and putting each triangle in its proper place.

CURLER UNITS

HERMAN VANGOUBERGEN

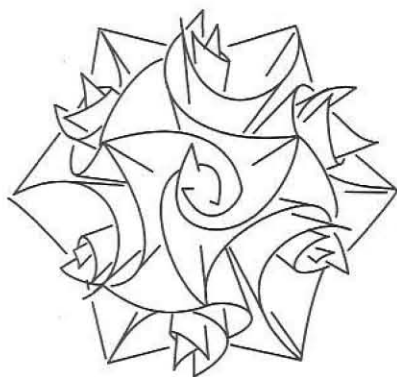
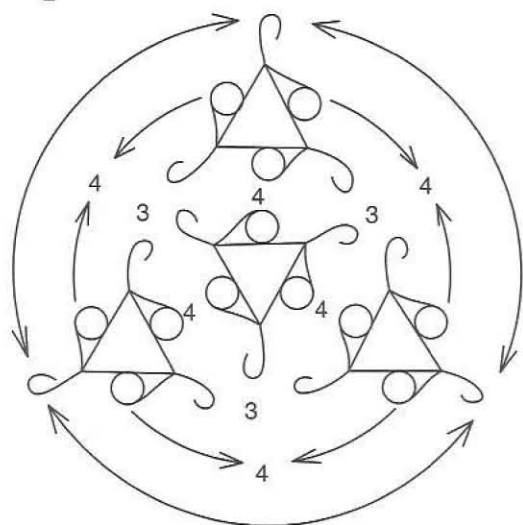
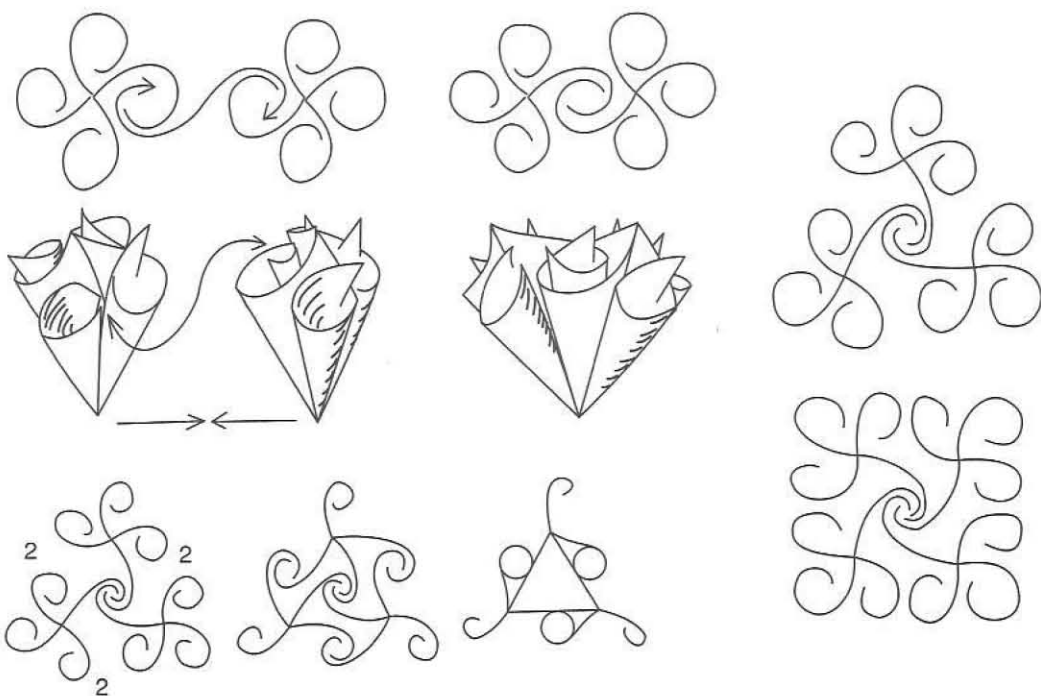
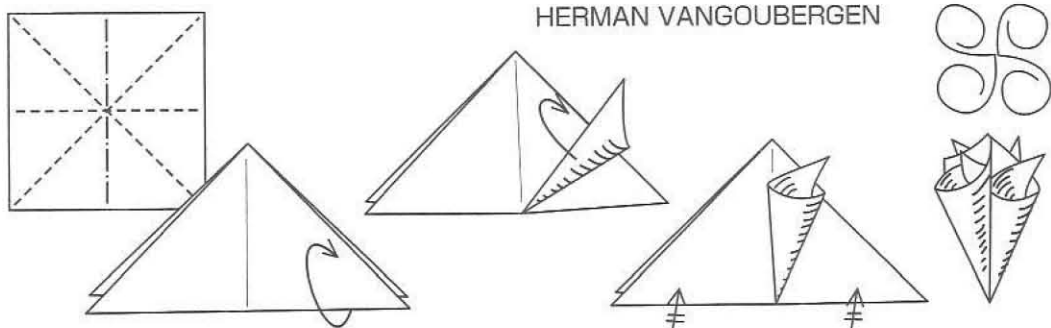

© HERMAN VANGOUBERGEN 2000

Use small squares (max 7x7 cm) of stiff paper. Ordinary origami paper is too thin, but photocopy paper works very well.

Make a waterbomb base and curl each of the flaps into a cone. As shown in the top view, all flaps are curled clockwise (left-handed folders may find it easier to work from a mirror image of these diagrams. sorry!).

The paper should stay curled up as indicated (that's why you need heavier paper) so initially you'll need roll up the flaps a bit tighter than shown in the diagrams as the curls will open out slightly when you let go.

To assemble the units, gently ease one curl inside another curl. You can combine 2, 3, 4, 5... curls this way to create many-armed vortexes. You can think of a 3-vortex as a triangle, a 4-vortex is a square and so on.

Combining the curls of a number of three units into vortexes you can make several different polyhedra.

The final drawing shows a cuboctahedron. For this, you'll need 12 units.

Join 3 units in a 3-vortex. Join the curls along the 3 edges of this "triangle" and add more units to make each of those linked curls into a 4-vortex. continue building the cuboctahedron until in the same vortex.

If you lose track of the curls, just remember that each square is surrounded by 4 triangles and each triangle is surrounded by 3 squares.

If this explanation doesn't work for you, try the diagrams at the left of the final drawing. first you join 3 units in a sub-assembly (which we simplify to a "curly triangle") and then join 4 of those sub-assemblies as indicated in the big diagram. The arrows and numbers indicate how many curls are joined at each position.

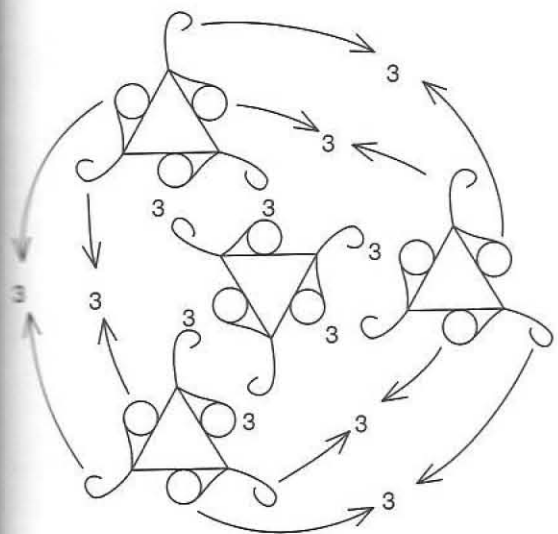

Further experiments :

TO make an icosidodecahedron (which consists of 3-vortexes and 5-vortexes) you'll need 30 units. Construction is similar to the cuboctahedron but here each pentagon is surrounded by 5 triangles and each triangle is surrounded by 3 pentagons.

When you make constructions with this many units, it's a good idea to make the curls a little tighter (and looser if you use less units, though such sparse assemblies are not as attractive and stable. The 6-unit octahedron, for instance, is rather fragile because the curls are overstretched).

You can construct other polyhedra this way but only if there are exactly 4 faces meeting at every corner (vertex) of the polyhedron. This is because the waterbomb base has exactly 4 flaps!

If you really want to make polyhedra with 3 faces meeting at the corners you could put 2 curls of a unit in the same vortex or tuck away the fourth flap inside the waterbomb base of just leave a curl unconnected (if there is enough room in the vortex) but non of those solution are very elegant.

To make the icosahedron (which has 5 faces meeting at each corner) we just leave a hole where the 5th face should go. As it's quite tricky to assemble, here's another diagram to help you.

You use the same 4 sub-assemblies as for the cuboctahedron, but put them together in a slightly different way.

The resulting figure is strangely irregular : it looks a bit like an icosahedron but not quite. The "holes" are pulled further apart than the "filled" triangular faces so the modular only has tetrahedral symmetry (and is in fact closely related to the sunb tetrahedron).

Here you see a strange property of these assemblies : the curls act as tiny rubber bands pulling the units together, so that the structure settles at an equilibrium position where the tension in all the curls is minimal (which is usually, but not always, quite a regular configuration).

For the adventurous :

A 4-unit tetrahedron is just possible. 3 curls of each unit are joined in 2-vortexes along the tetrahedron's edges, the fourth is unconnected.

Or try the 10 unit deltoidal icositetrahedron. All curls are joined in 3-vortexes and those corners of the icositetrahedron where 3 faces meet are left as holes. that's why we only need 18 units instead of 26.

Make a 24-unit snub cube, either leaving the 6 square faces as holes or leaving 8 triangular faces as holes (choose those triangles not sharing any edges with the squares)

CHI MODULAR

HELMAN VAN GOUBERGEN

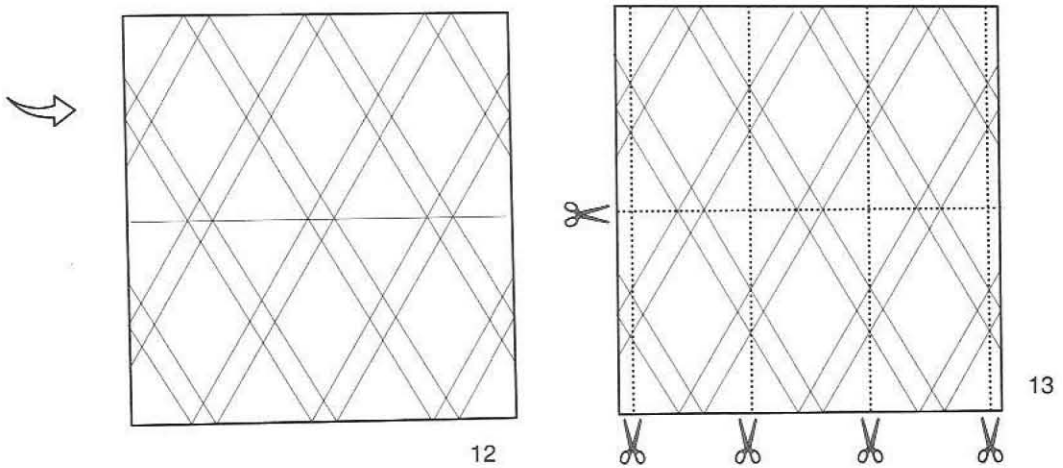
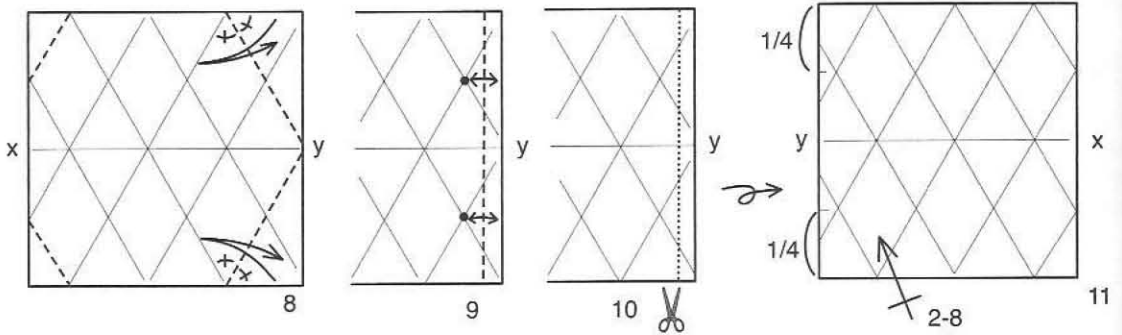
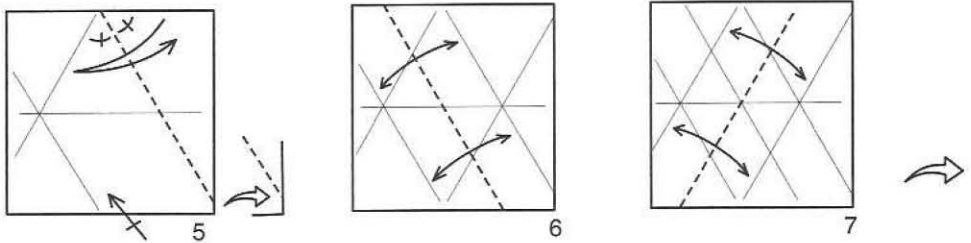
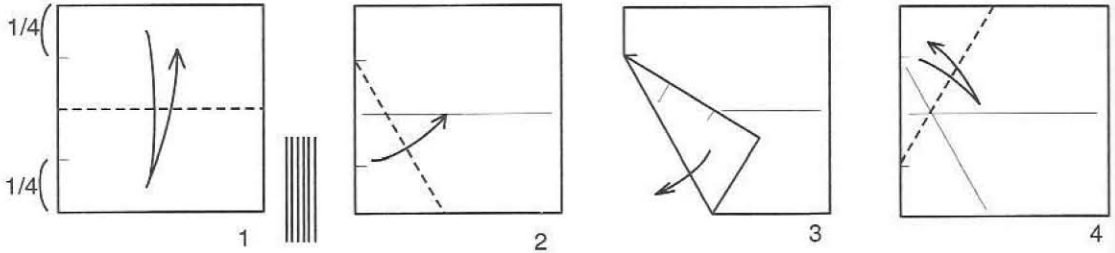

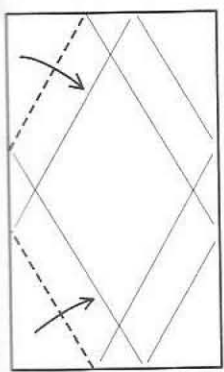

14

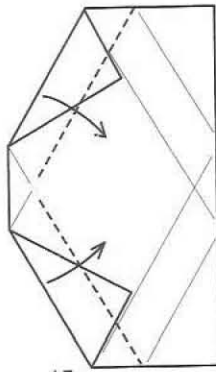

15

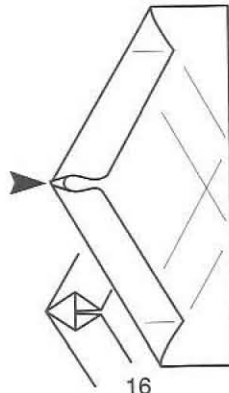

16

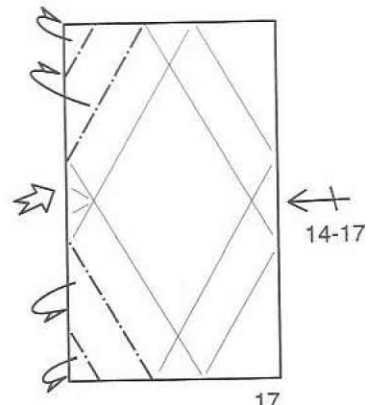

17

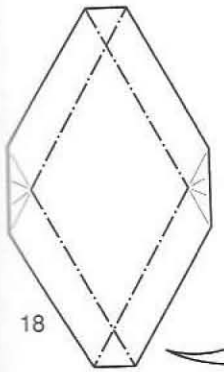

18

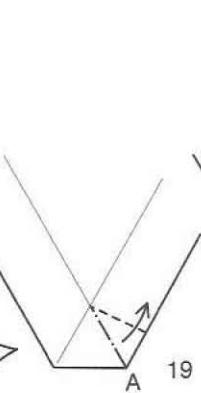

19

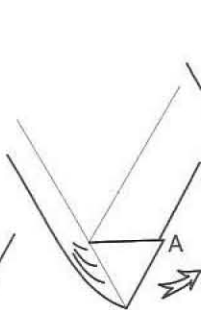

20

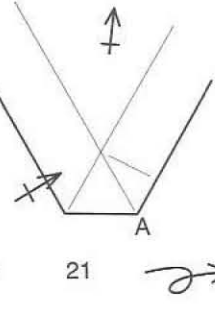

21

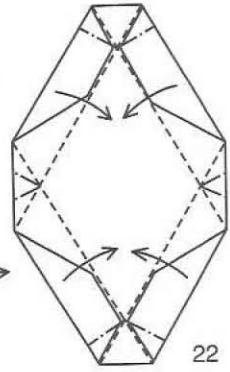

22

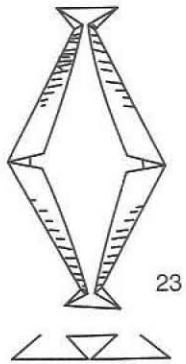

23

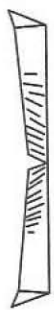

24



25

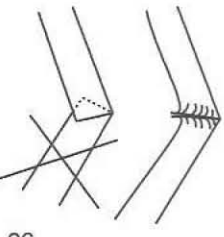
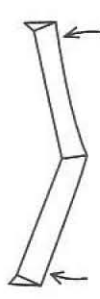

26

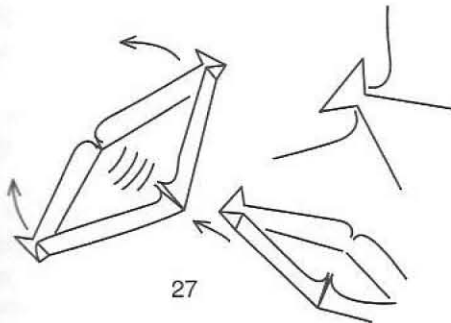

27

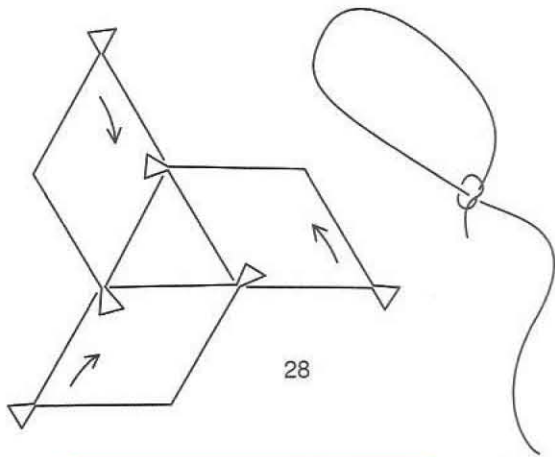

28

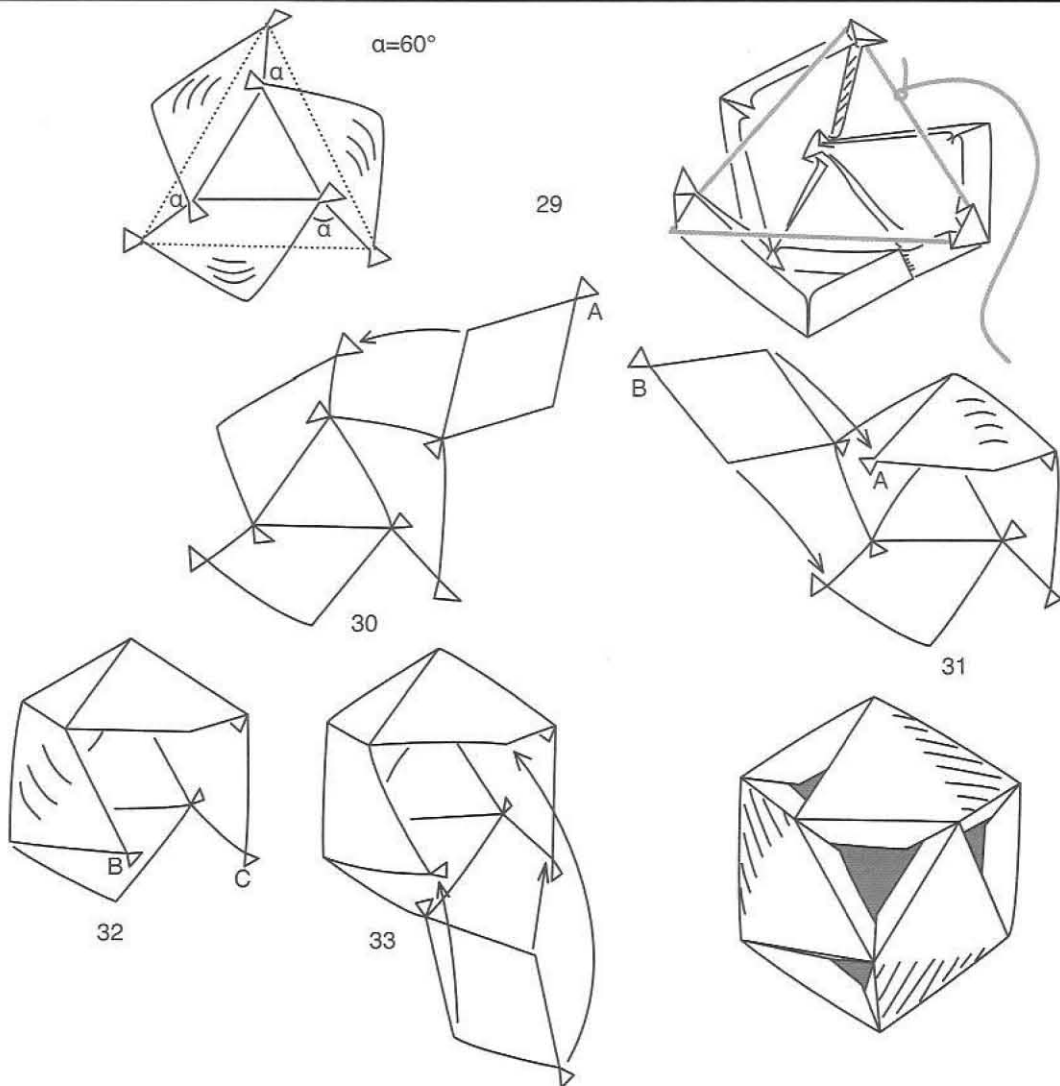

Warning: Assembly is quite Difficult!

Use a square at least 20x20 cm, the paper needs to be heavier and springier than ordinary origami paper. Photocopy paper works well.

The direction of the grain is indicated in the first drawing.

11. mark 2 quarters and repeat everything starting from the other edge of the paper. in this way you add another (shifted) grid of folds.
23. curve the edges. If you gently bend the module as indicated in 26, these edges shouldn't overlap but touch and "Buckle" inwards together.
27. the models will only grip one another if you gently bend each of them as indicated in 26. Before you start assembling them in is important to verify that each module is capable of gripping another one this way. If not, you may have to :
curve the edges a bit more (24)
keep the ridges folded inwards (23, bottom drawing)

28. Very difficult : you'll need at least three hands!

Take a piece of string and make a slip knot. Put together 2 modules, keeping all of them slightly bent so that each grips the other one.

Lock them in this position by slipping the loop of the lasso over the triangular tabs at the top. Tighten the loop until the modules are in the indicated position (29). The angle of the triangular gaps should be about 60 degrees. Relax.

30-32. add one module at a time. keep everything under tension all the time if you don't want the whole thing to explode !

32. If you hold the assembly between your fingers at points B and C it will be stable. Relax. (No, not those fingers !)

33. A final effort : the last module locks everything. you can get rid of the string now. Congratulations : you have tamed the wild modules !

Crease Pattern Challenge!

Wall-E robot

Brian Chan

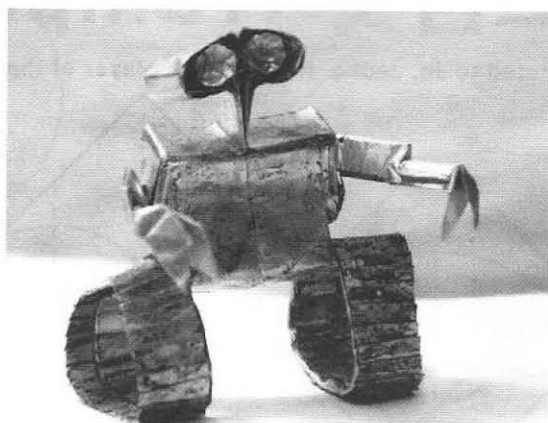

この作品は、第14回折紙探偵団コンベンションの参加者配布用バッジのデザインに採用されました。

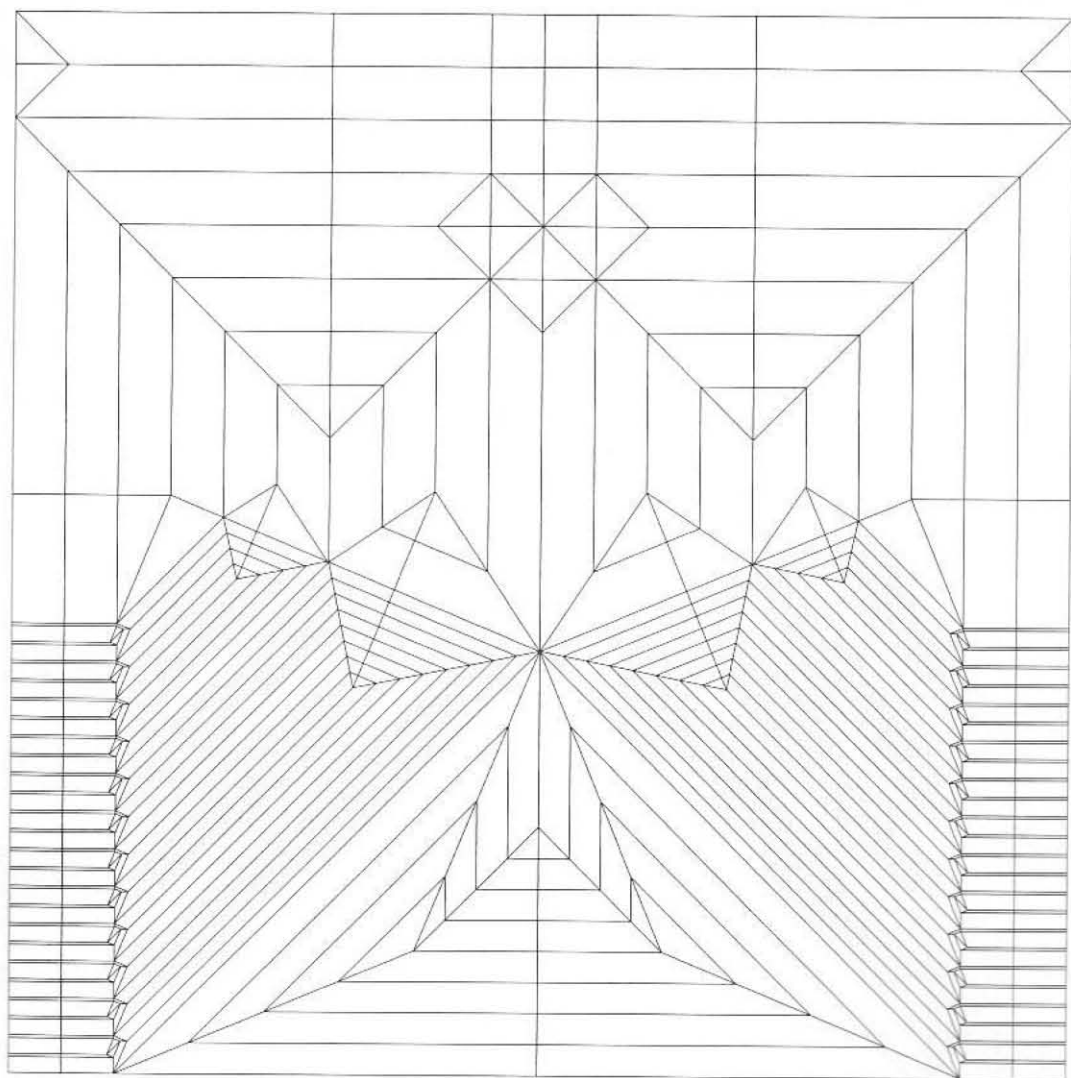

트럼펫 Trumpet

model & diagrams by
jassu(Oh, Kyu-Seok)
2008. 6. 6.

Dedicated to Jo, Jeong-Hyeon (Jazz player of the Trumpet)

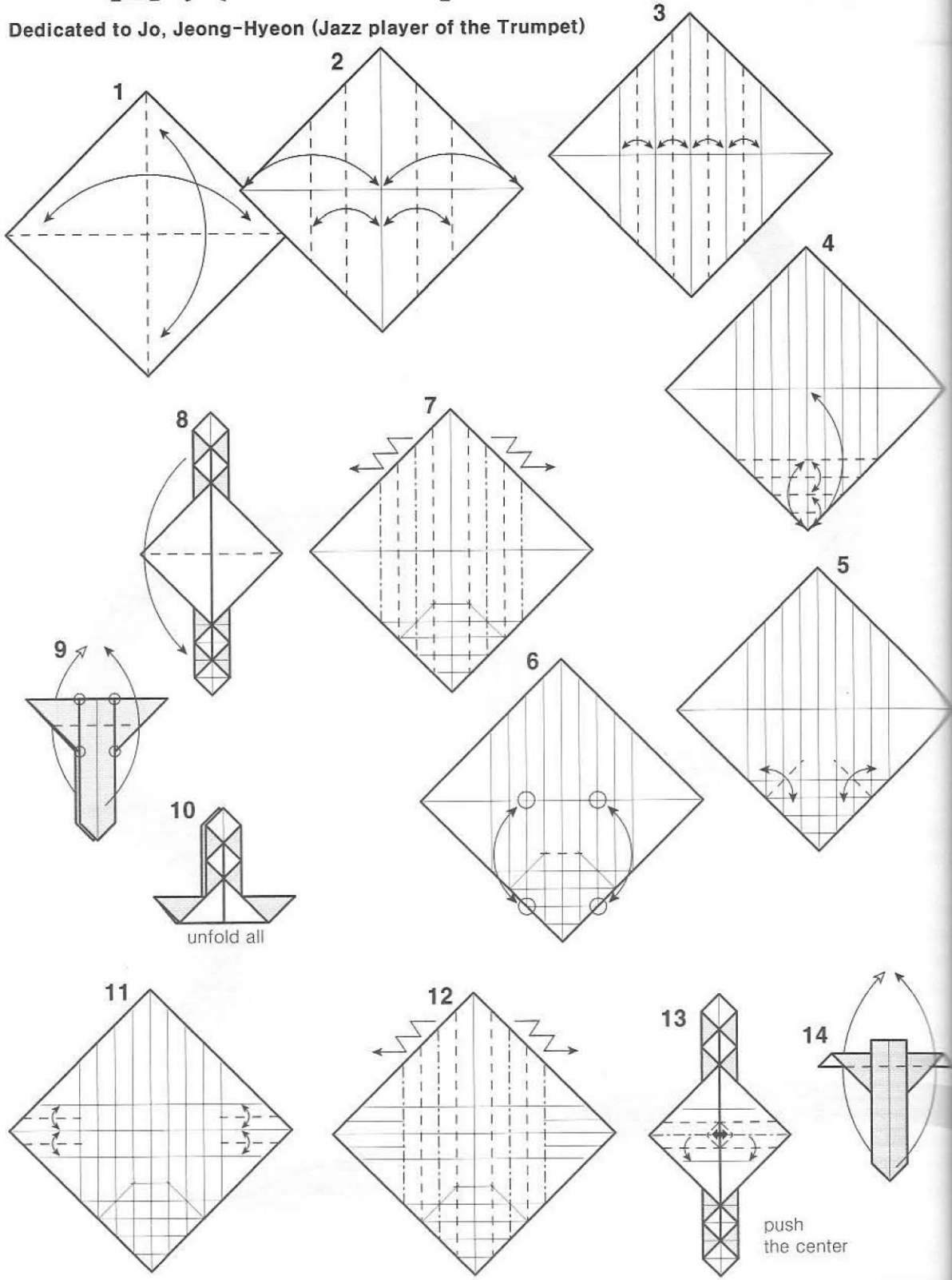

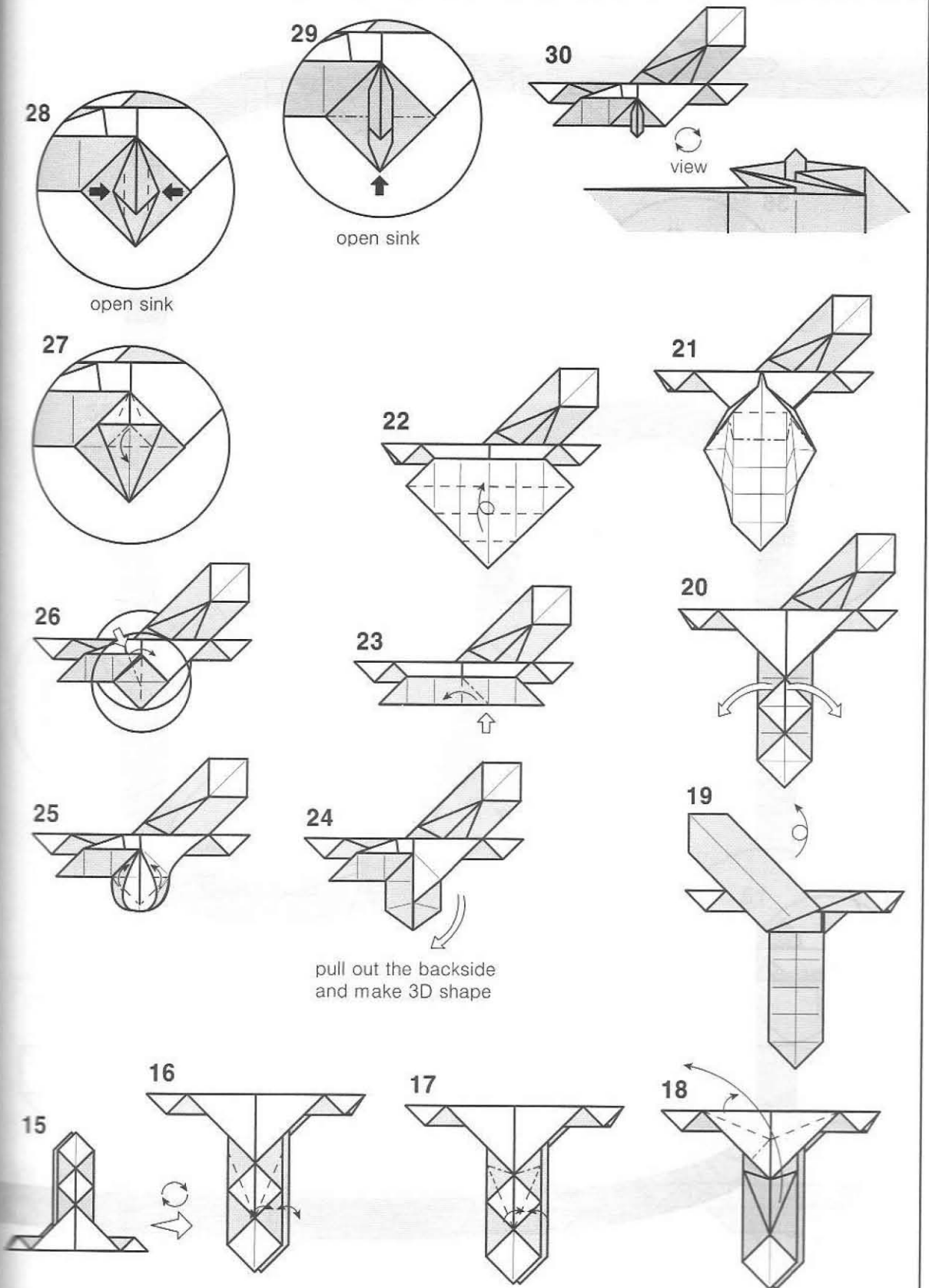

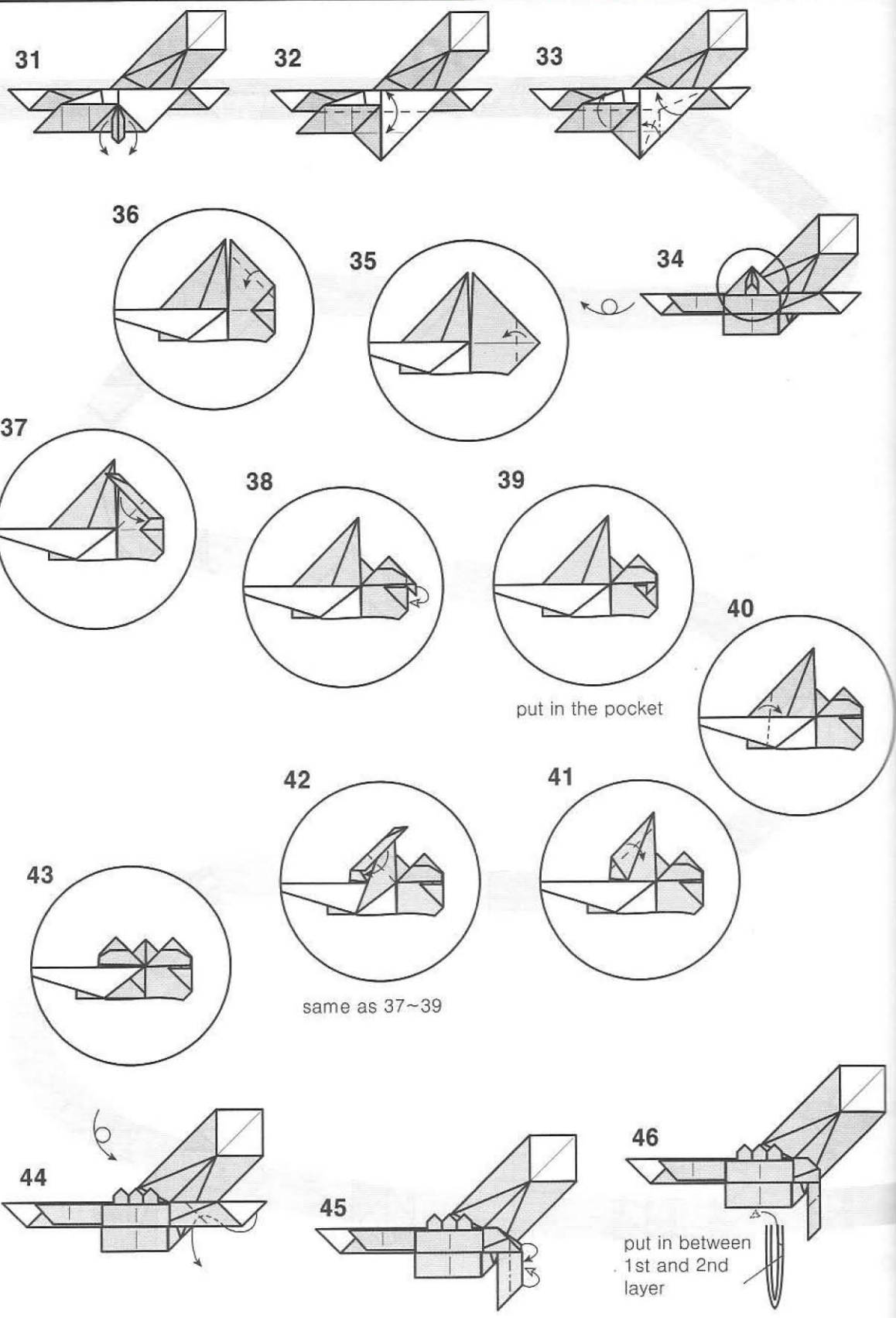

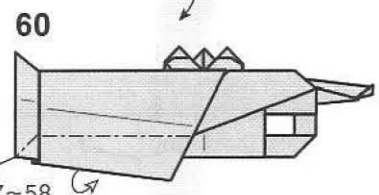
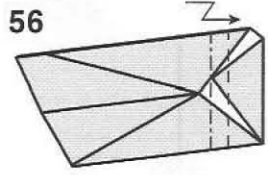
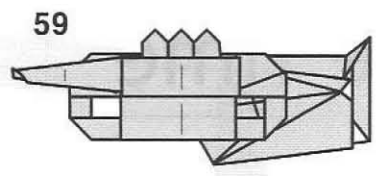
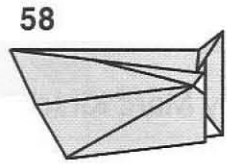
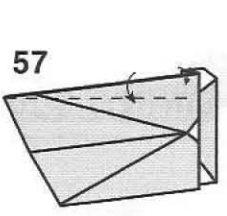

same as 57~58

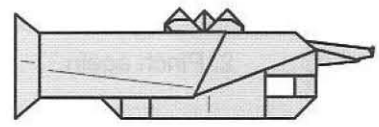
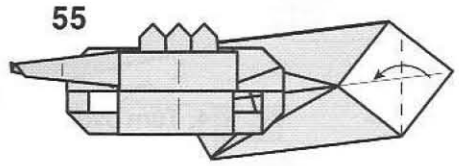

Finish Trumpet!

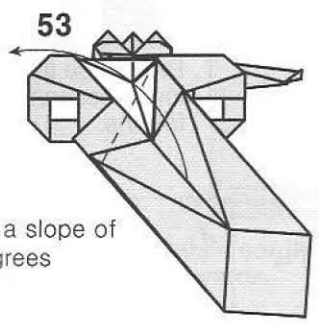
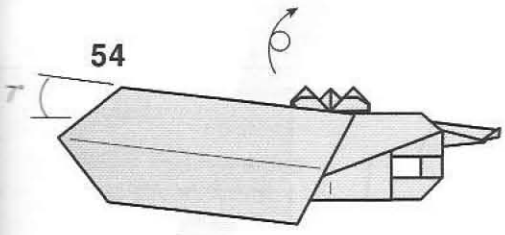
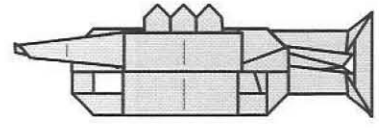

need a slope of 7 degrees

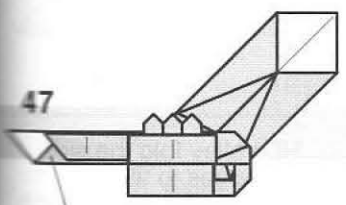
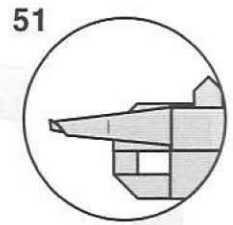
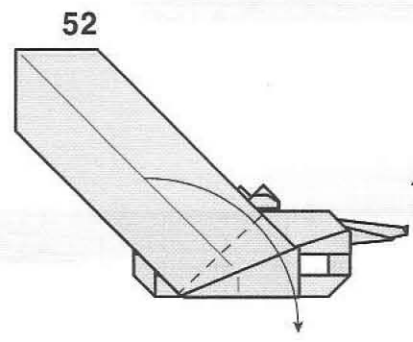

same as 44~46

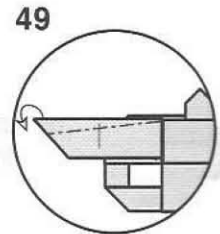
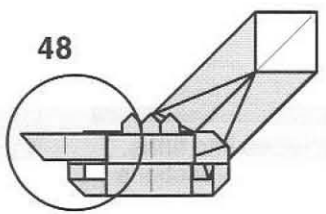

Tee Time

by Marc Kirschenbaum (NY) ©2007

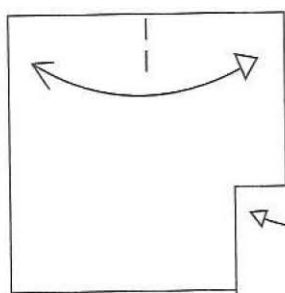

1. Pinch the top in half.

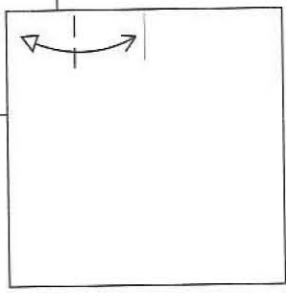

2. Pinch again.

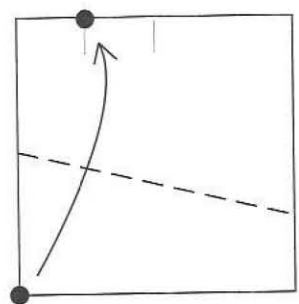

3. Valley fold the corner to the crease.

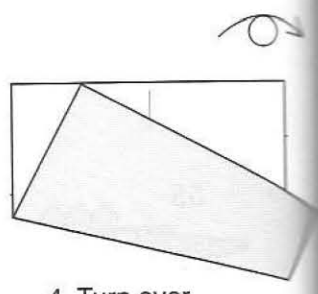

4. Turn over.

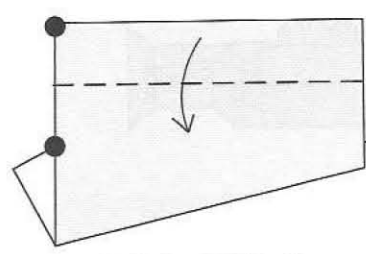

5. Valley fold to the intersection of raw edges.

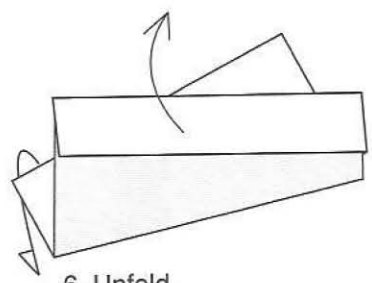

6. Unfold.

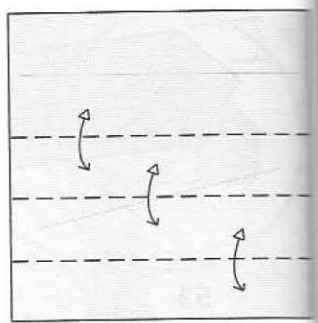

7. Precrease the lower section into fourths.

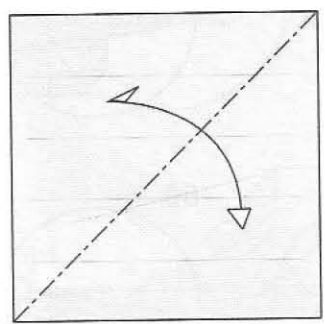

8. Precrease along the diagonal with a mountain fold.

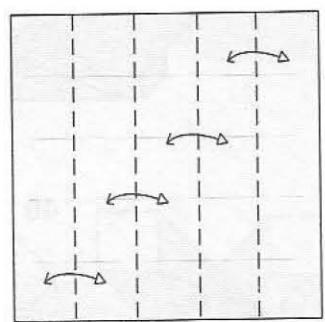

9. Precrease into fifths. Use the intersections of the diagonal crease as a guide. Turn over.

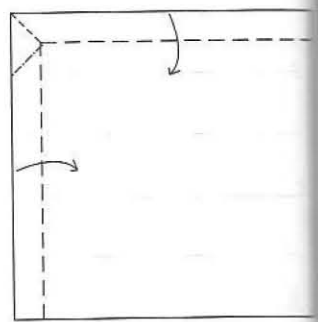

10. Valley fold the side edges to the creases, while rabbit earing the corner.

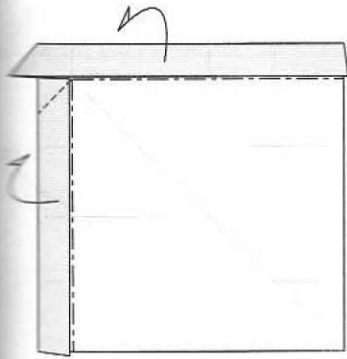

11. Mountain fold along the existing creases, swiveling behind.

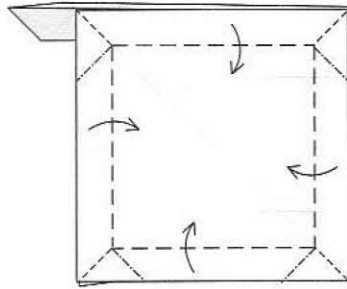

12. Valley fold the sides inwards, allowing swivels to form.

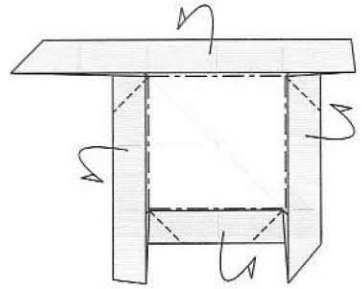

13. Mountain fold along the existing creases, swiveling behind.

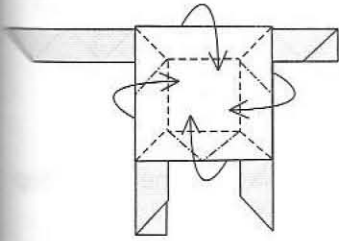

14. Valley fold the sides inwards, allowing swivels to form.

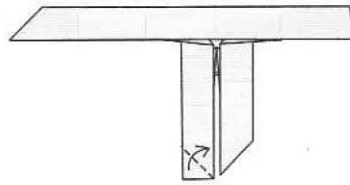

15. Valley fold the corner.

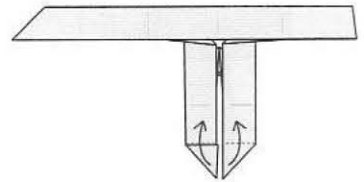

16. Valley fold the flaps up.

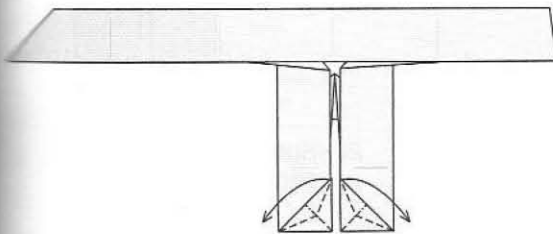

17. Rabbit ear the flaps outwards.

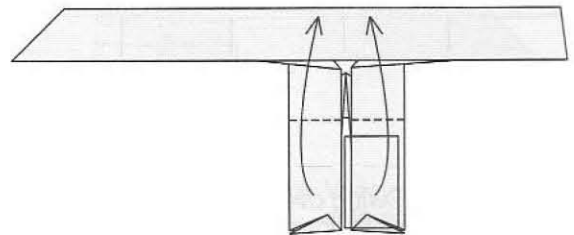

18. Valley fold the flaps up, to align with the folded edge in the rear.

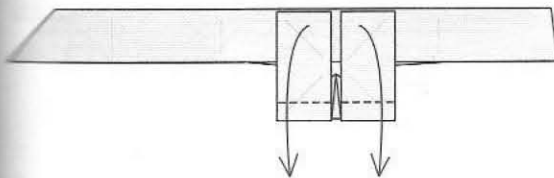

19. Valley fold the flaps down at approximately 1/3rd the indicated distance.

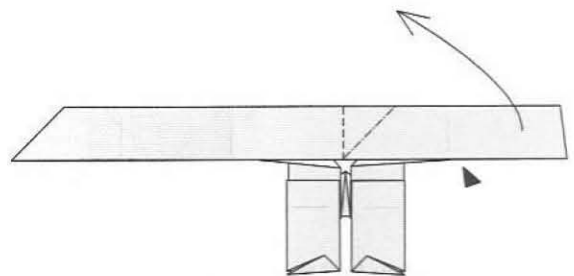

20. Squash fold the flap up.

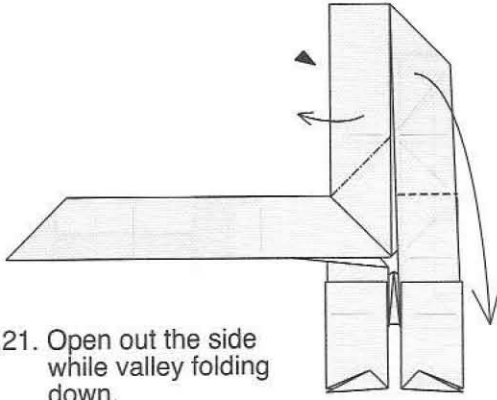

21. Open out the side while valley folding down.

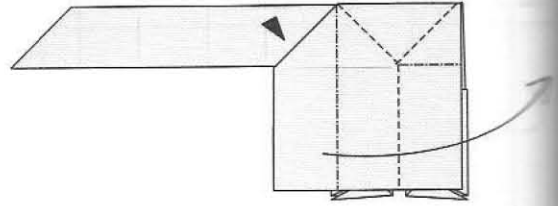

22. Rabbit ear the flap outwards.

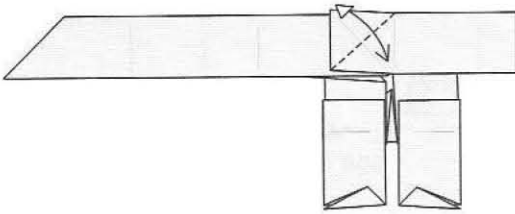

23. Precrease the center flap.

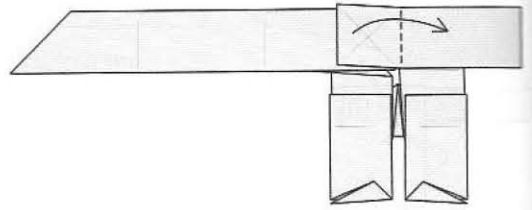

24. Valley fold the center flap over.

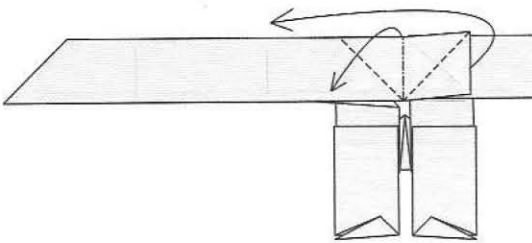

25. Swing over the center flap while incorporating a reverse fold.

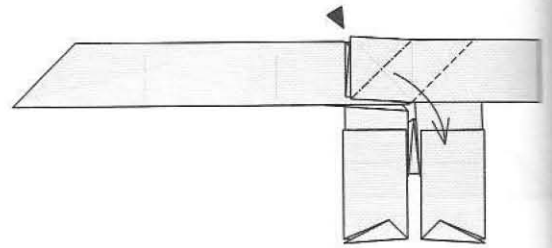

26. Spread squash the center flap down.

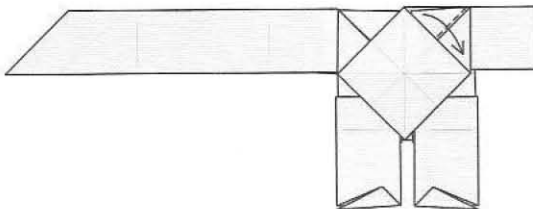

27. Valley fold the flap down.

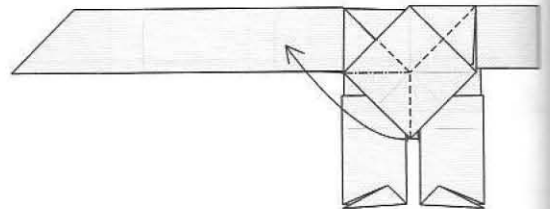

28. Rabbit ear the center flap.

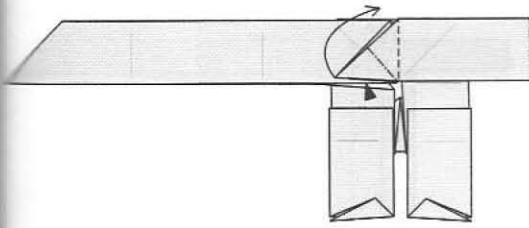

29. Squash fold.

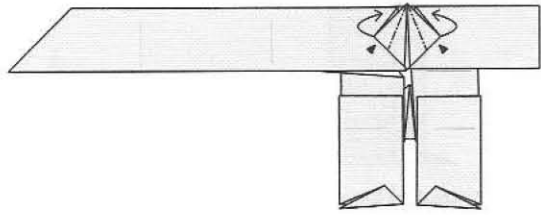

30. Reverse fold the sides.

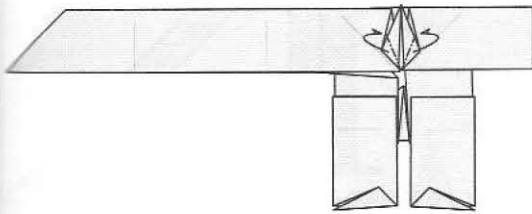

31. Mountain fold the sides.

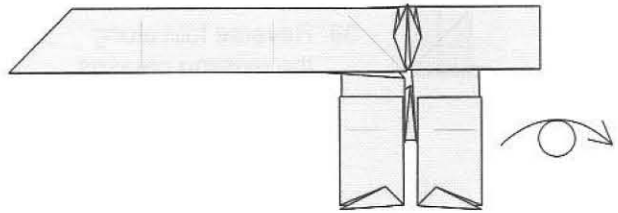

32. Turn over.

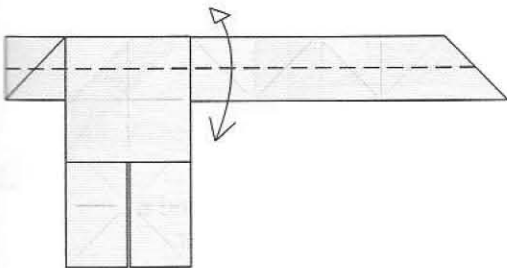

33. Precrease the top edge in half.

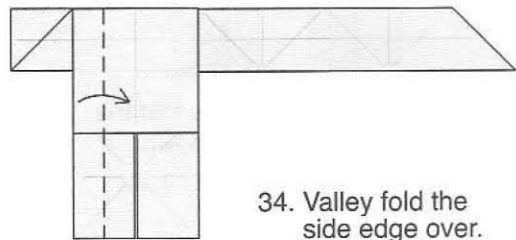

34. Valley fold the side edge over.

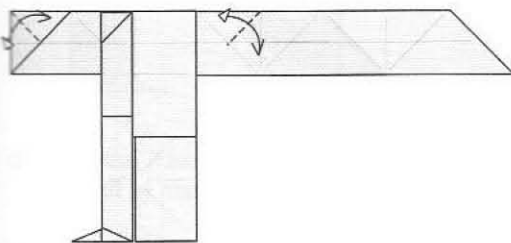

35. Precrease along the angle bisectors.

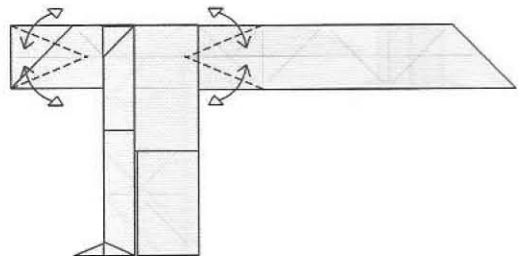

36. Precrease along the angle bisectors.

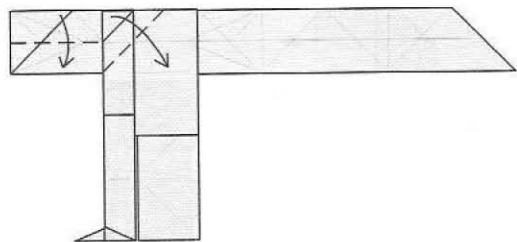

37. Valley fold the thick center flap over while valley folding the left flap in half.

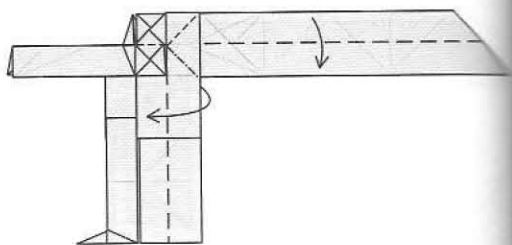

38. Valley fold the two flaps in half, allowing a swivel to form.

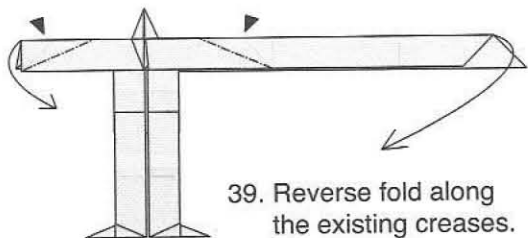

39. Reverse fold along the existing creases.

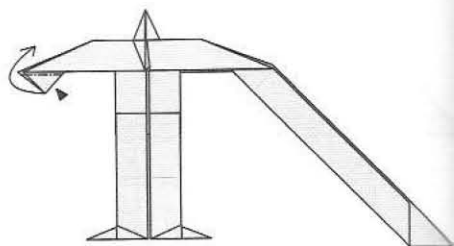

40. Reverse fold the corner up.

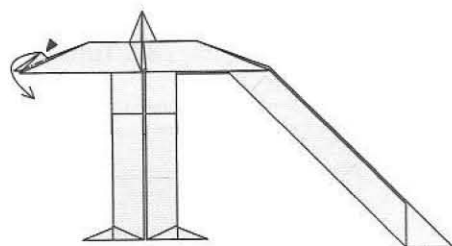

41. Reverse fold the corner down.

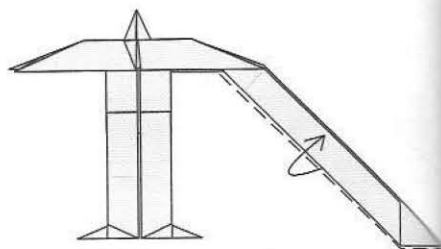

42. Wrap around a single layer.

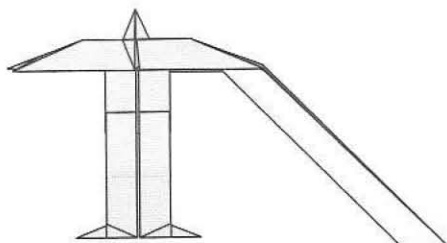

43. Turn over.

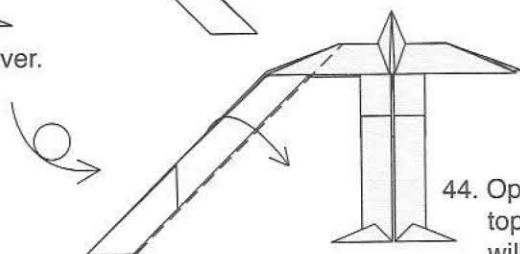

44. Open out the top layer. The tip will not lie flat.

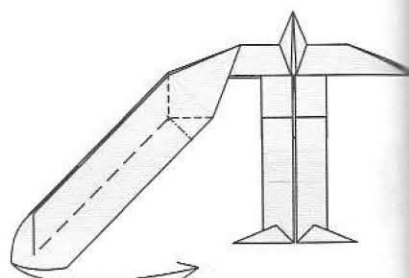

45. Rabbit ear the flap down to flatten.

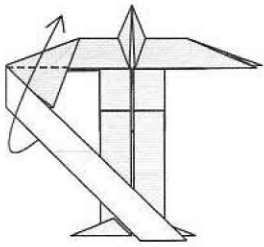

46. Valley fold the flap up.

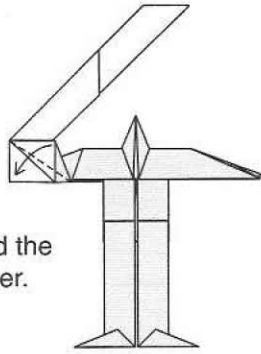

47. Valley fold the corner over.

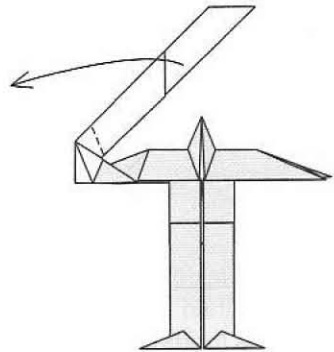

48. Valley fold the flap over so it lies straight.

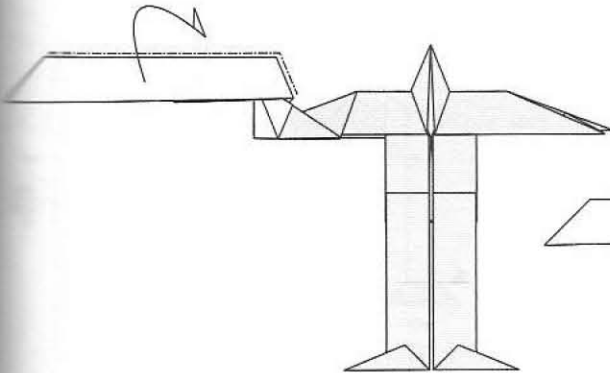

49. Wrap around a single layer.

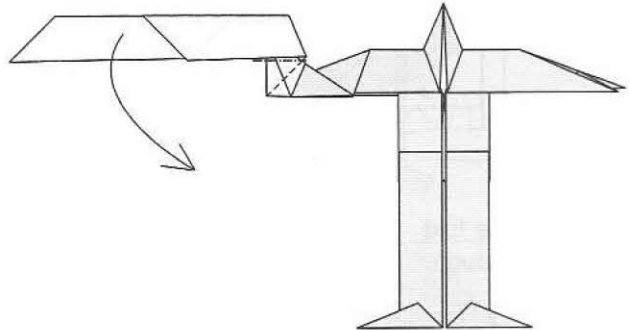

50. Pleat the flap downwards.

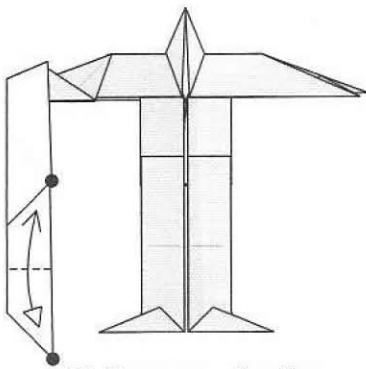

51. Precrease the flap.

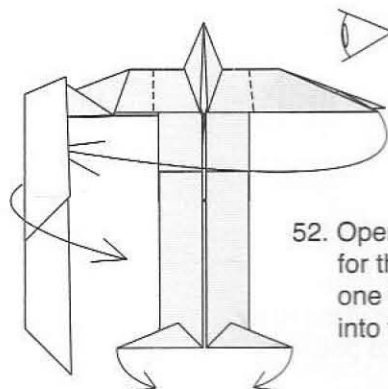

52. Open out the flaps for the feet. Tuck one of the points into the pocket.

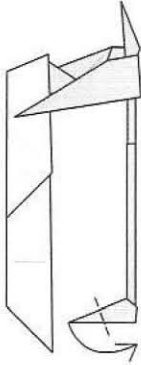

53. View from previous step. Mountain fold the tips of the flaps for the feet.

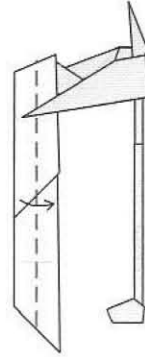

54. Valley fold the flap in half, locking the arm in place.

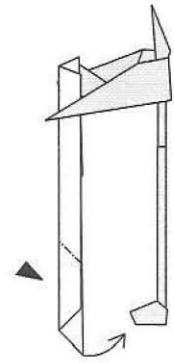

55. Form a reverse fold, using the crease from step 51 as a guide.



56. Reverse fold the flap through.

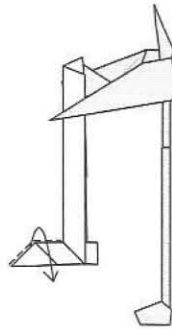

57. Wrap around a single layer, allowing a swivel to form internally.

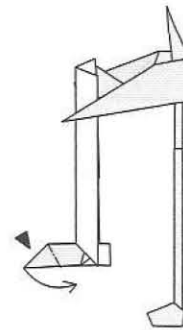

58. Reverse fold the tip.

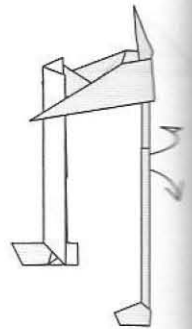

59. Open out the sides.

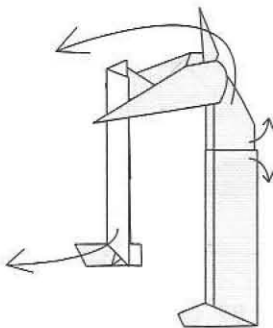

60. Spread apart the side pleats and pull the body and club into position.

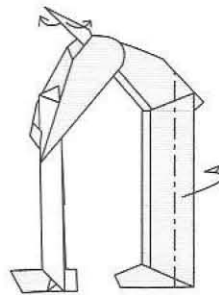

61. Open out the sides of the head and round the sides of the body.

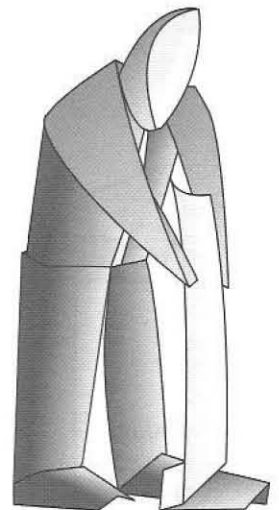

62. Completed Tee Time©
©2007 Marc Kirschenbaum©

FUGU

Designed by Siphon Mabona 2006

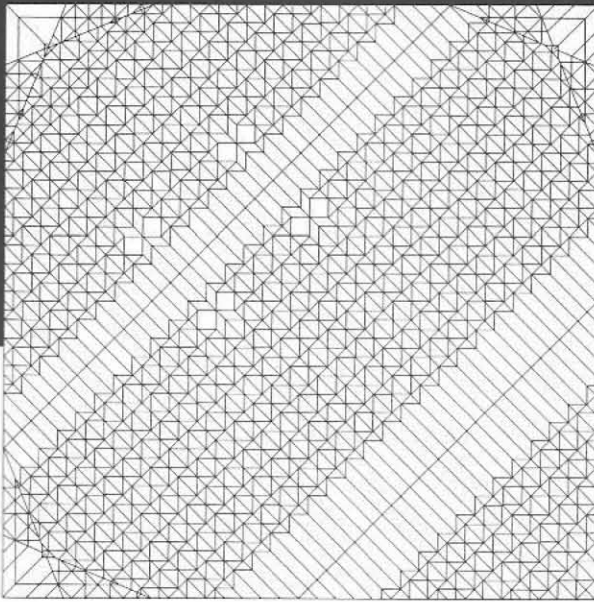

The first version of this FUGU or BLOWFISH was my entry to the 2006 Italian Convention design challenge themed water. I had wanted to use the waterbomb-tessellation for representational model for a long time. Using the tessellation for the body, the obvious solution for the placement of the fins were the corners of the paper. Wet folding and the use of methyl cellulose are necessary. I have struggled to find the right paper for this model. Use a thin sheet (ca. 20 gsm) of strong paper. I recommend a sheet >50x50cm.

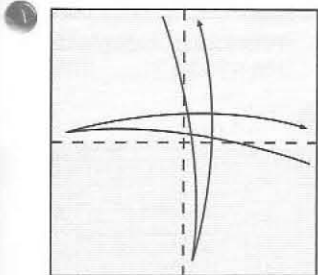
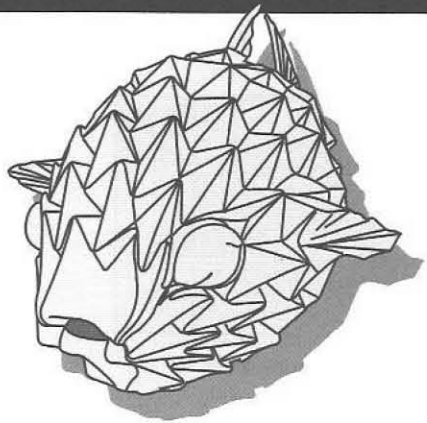

1 Use a one colored sheet. Fold in half and unfold.

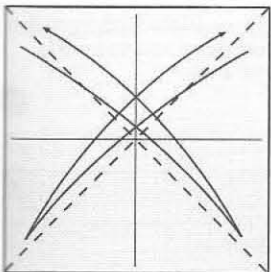

2 Fold and unfold diagonally.

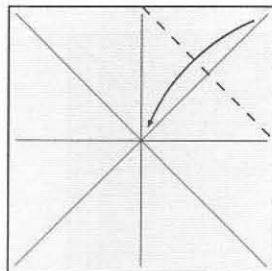

3 Fold the corner to the center. Turn over.

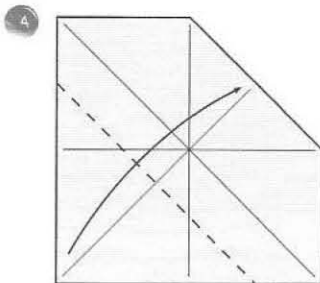

4 Fold the corner to the edge.

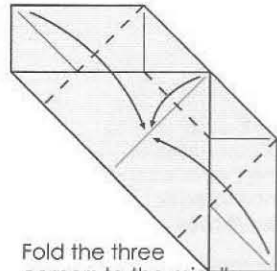

5 Fold the three corners to the middle. Rotate 45 degrees.

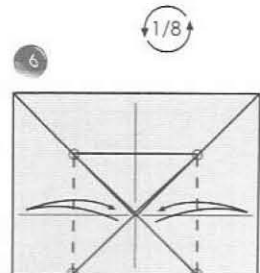

6 Fold the corners to the edges and unfold.

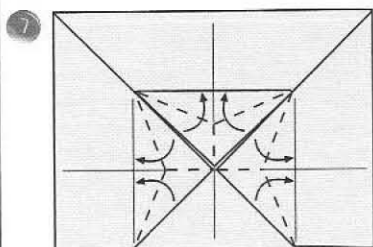

7 Rabbit-ear the three corners. After this step apply Methyl Cellulose between all layers of the model except for the loose fins. Beware of the fact that the paper expands when dampened. Mount the model on glass or a similar surface and continue folding when dry.

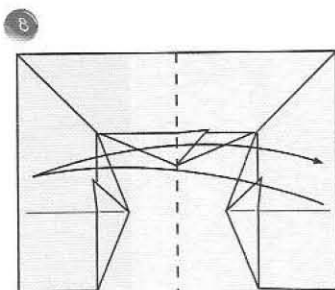

8 Fold in half and unfold.

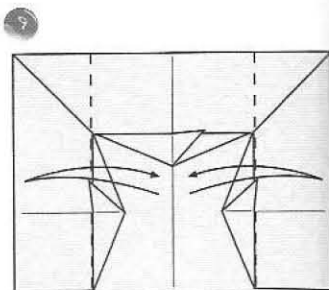

9 Fold fourths and unfold.

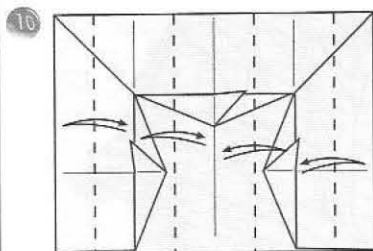

10 Fold eighths and unfold.

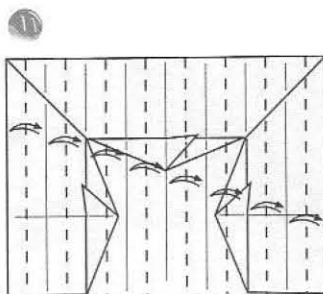

11 Fold 16ths and unfold. Avoid folding the middle fin.

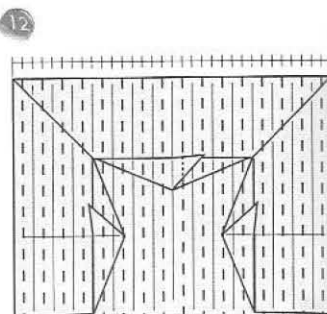

12 Fold 32nds. Avoid folding the middle fin.

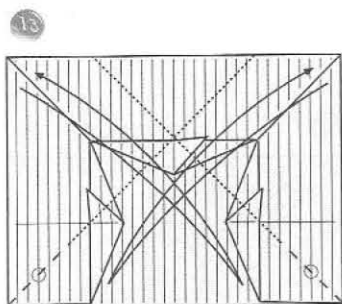

13 Mark the points where the diagonals intersect the third vertical creases.

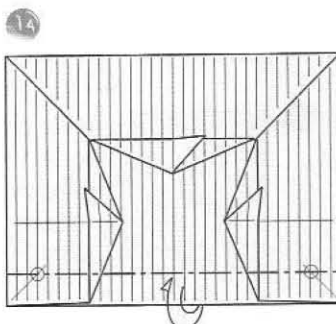

14 Mountain-fold through the marked points.

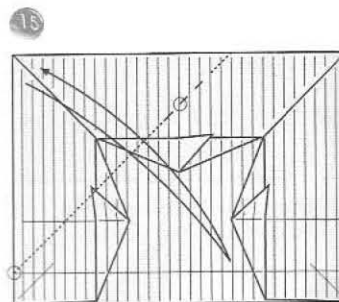

15 Mark the point where the diagonal originating from the circled point intersects the middle line.

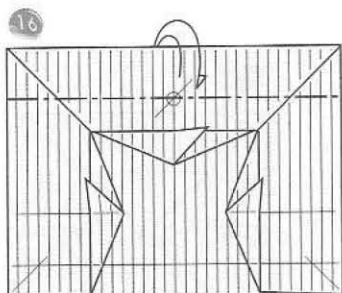

16 Mountain-fold through the marked point. Turn over.

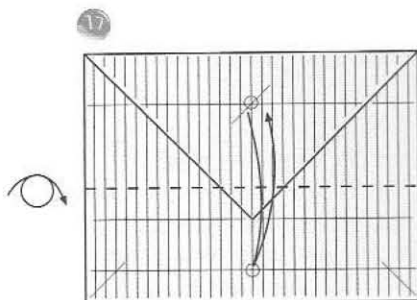

17 Fold halfway between the existing creases.

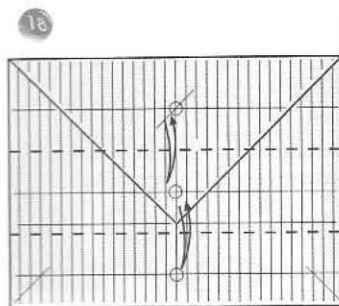

18 Fold fourths of the distance between the existing creases.

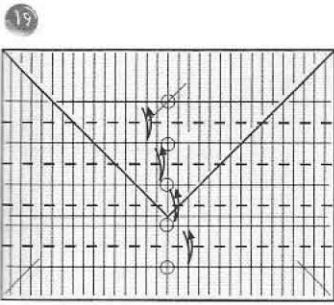

19 Fold eighths of the distance between the existing creases. Turn over.

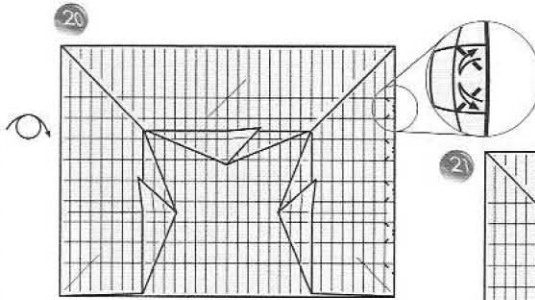

20 Fold small diagonals as indicated.

Mountain-fold at 2/32.

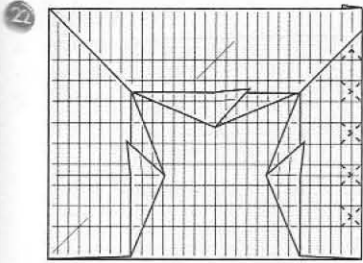
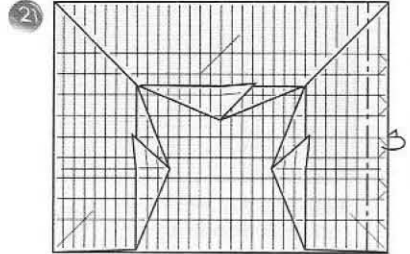

22 Fold small diagonals through all layers.

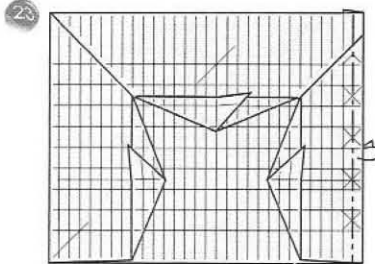

23 Replace the mountain fold made in step 21 by one at 3/16.

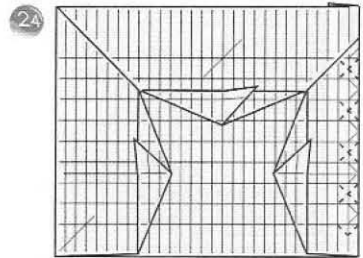

24 Fold small diagonals through all layers.

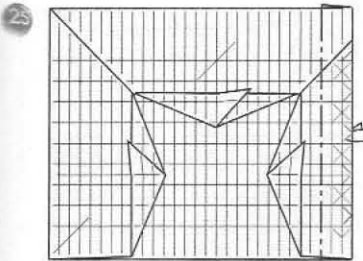

25 Replace the mountain fold made in step 23 by one at 6/32.

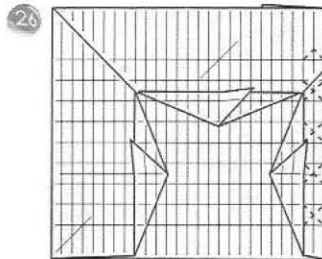

26 Fold small diagonals through all layers.

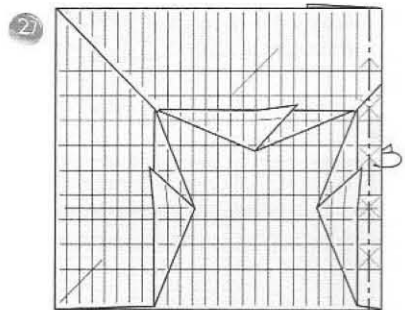

27 Replace the mountain fold made in step 25 by one at 7/32.

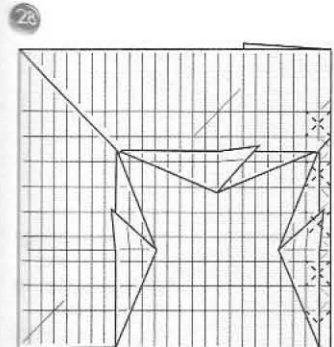

28 Fold small diagonals through all layers.

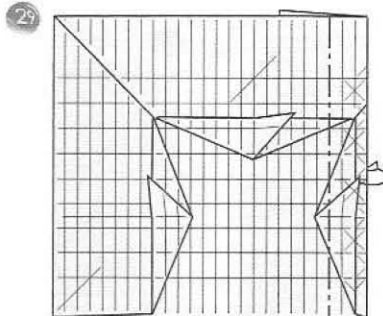

29 Replace the mountain fold made in step 27 by one at 10/32.

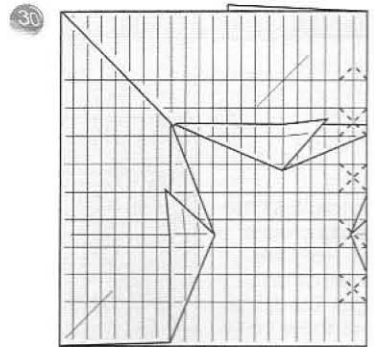

30 Fold small diagonals through all layers.

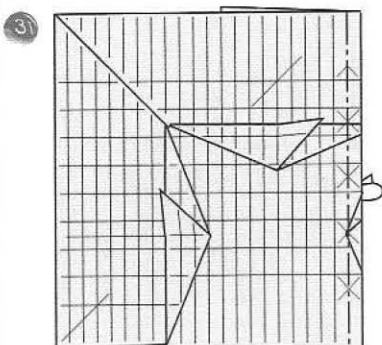

31 Replace the mountain fold made in step 29 by one at 11/32.

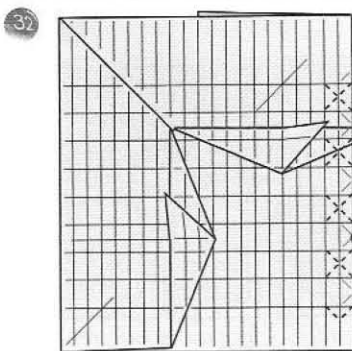

32 *Fold small diagonals through all layers.

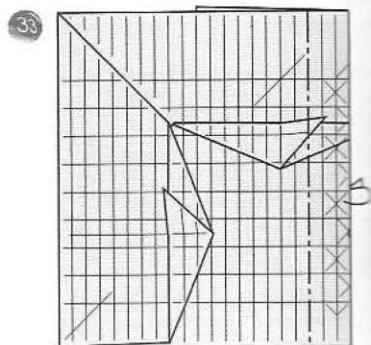

33 Replace the mountain fold made in step 31 by one at 14/32.

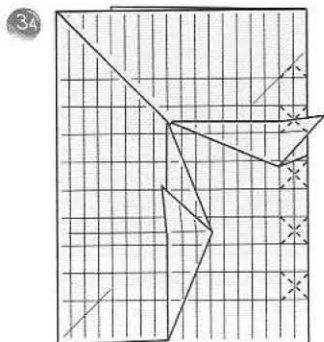

34 Fold small diagonals through all layers.

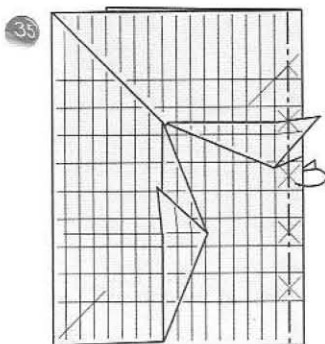

35 Replace the mountain fold made in step 31 by one at 15/32.

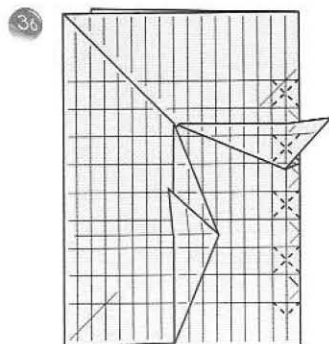

36 Fold small diagonals through all layers. Then repeat steps 20-34 on the other side.

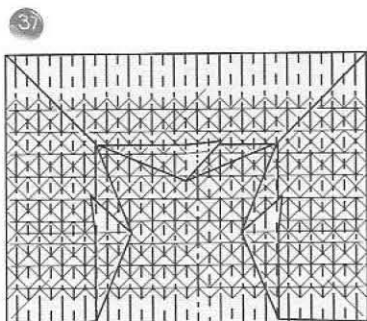

37 Pre-crease alternating mountain and valley folds.

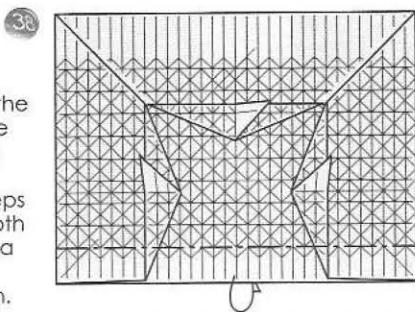
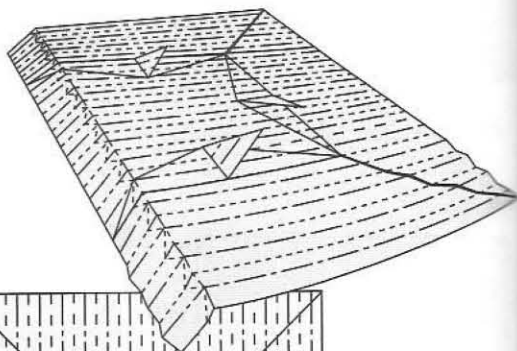

38 Mountain-fold the existing crease lines. Hold the crease at an angle. The Steps 39-43 show both 3-D view and a progressive crease pattern.

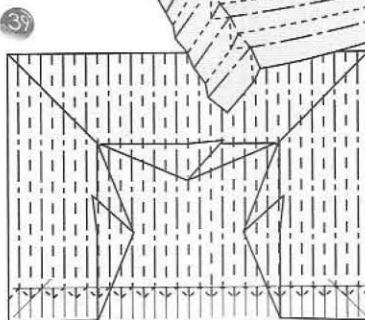

39 Fold alternating mountain and valley-creases as well as valley folds on the small diagonals.

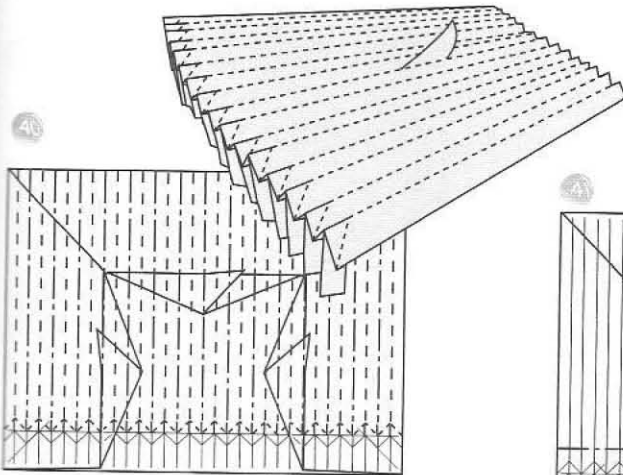

Reverse the mountain and valley folds as you valley-fold a row of diagonal creases.

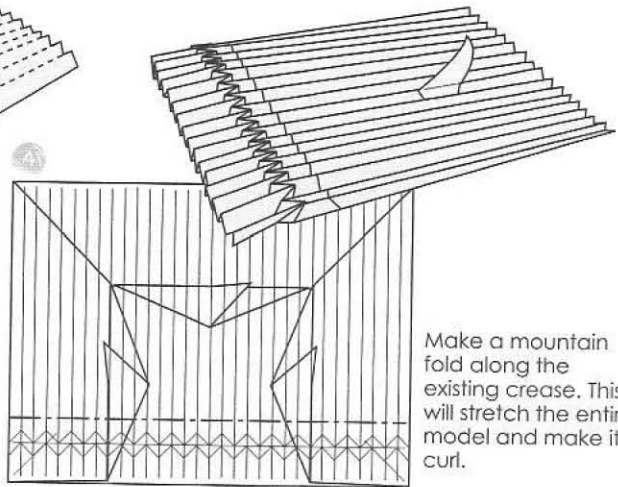

Make a mountain fold along the existing crease. This will stretch the entire model and make it curl.

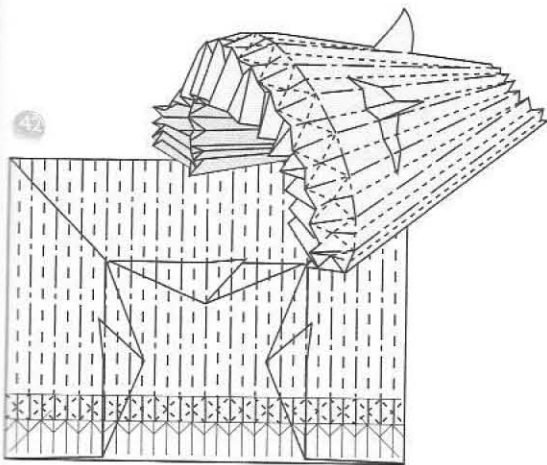

Collapse a row of waterbombs.

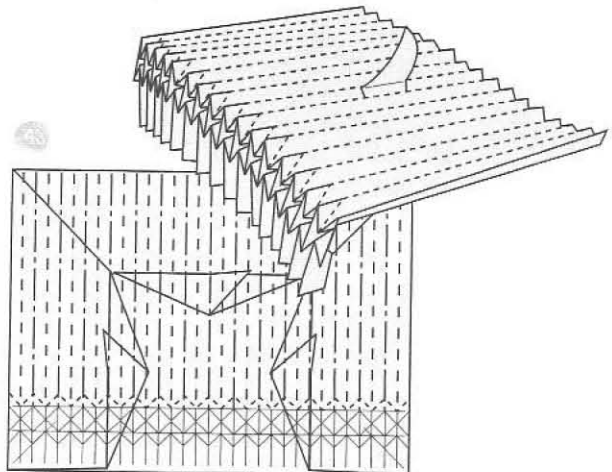

Reverse the mountain and valley folds as you valley-fold a row of diagonal creases.

Steps 44-63 are progressive crease-patterns illustrating how to repeat steps 41-43 on the following rows.

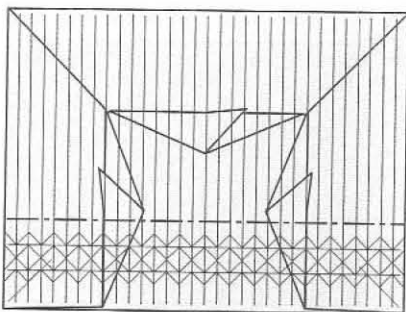

Make a mountain fold along the existing crease.xy

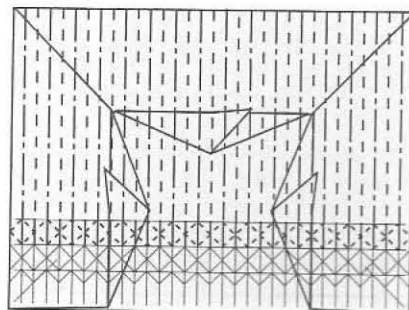

Collapse a row of waterbombs.

46

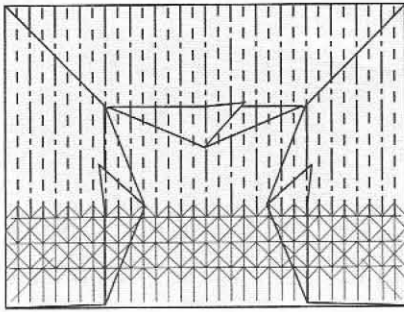

Reverse the mountain and valley folds as you valley-fold a row of diagonal creases.

47

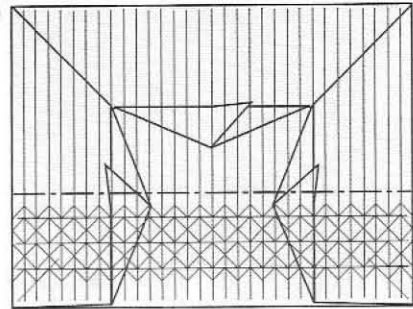

Make a mountain fold along the existing crease.

48

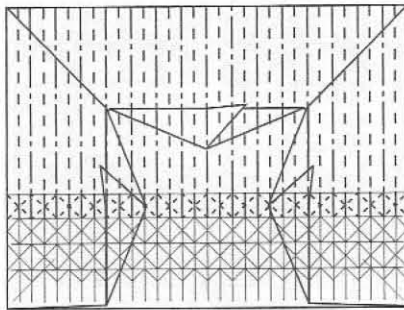

Collapse a row of waterbombs.

49

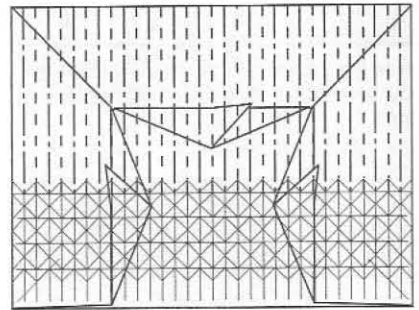

Reverse the mountain and valley folds as you valley-fold a row of diagonal creases.

50

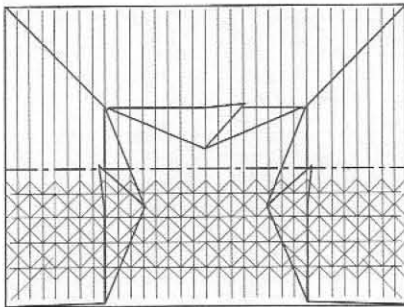

Make a mountain fold along the existing crease.

51

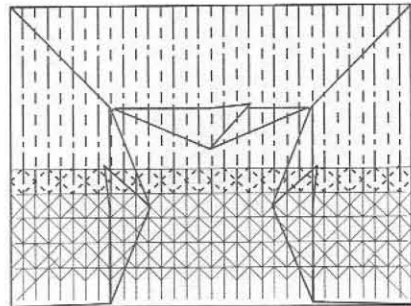

Collapse a row of waterbombs.

52

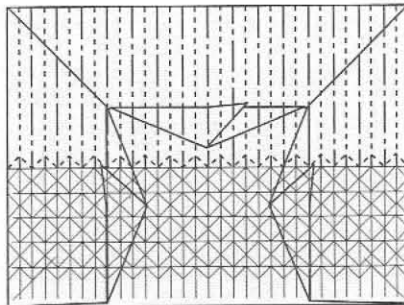

Reverse the mountain and valley folds as you valley-fold a row of diagonal creases.

53

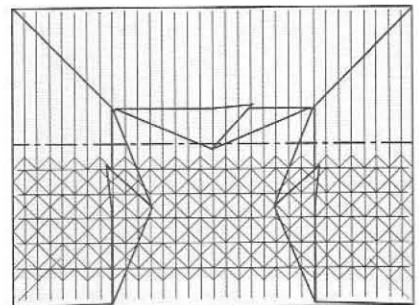

Make a mountain fold along the existing crease.

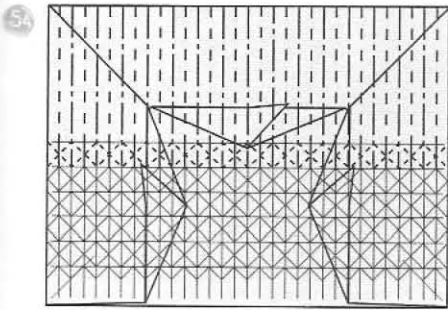

Collapse a row of waterbombs.

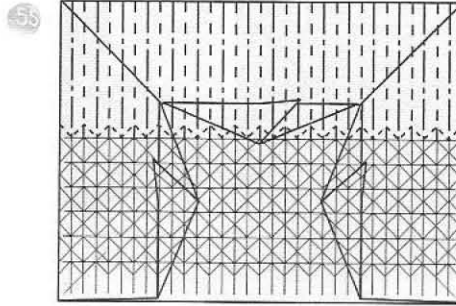

Reverse the mountain and valley folds as you valley-fold a row of diagonal creases.

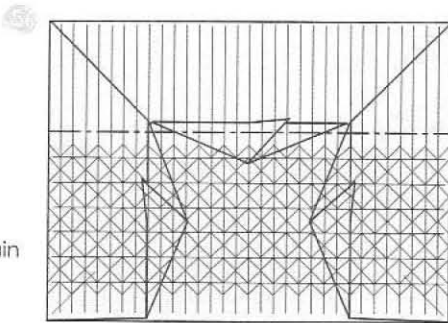

Make a mountain fold along the existing crease.

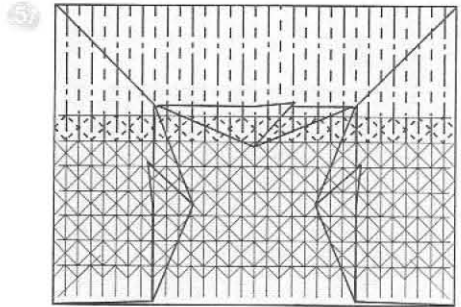

Collapse a row of waterbombs.

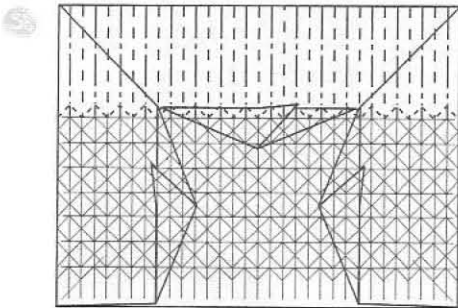

Reverse the mountain and valley folds as you valley-fold a row of diagonal creases.

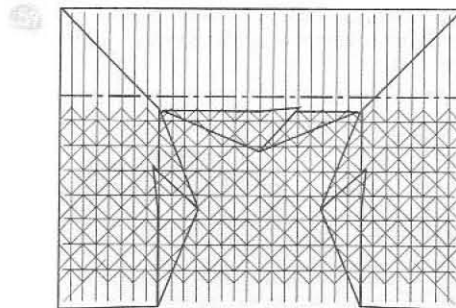

Make a mountain fold along the existing crease.

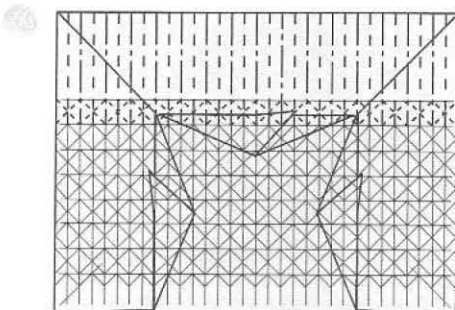

Collapse the a row of waterbombs.

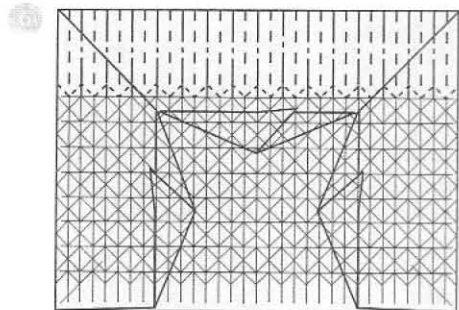

Reverse the mountain and valley folds as you valley-fold a row of diagonal creases.

62

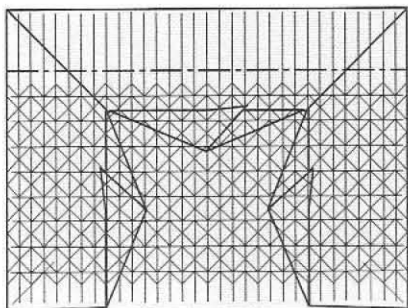

Make a mountain fold along the existing crease.

63

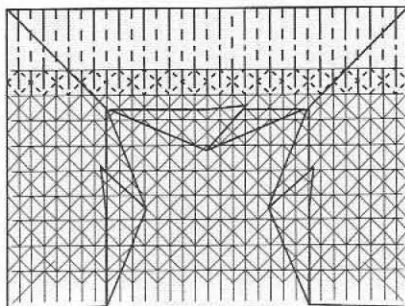

Collapse a row of waterbombs.

64

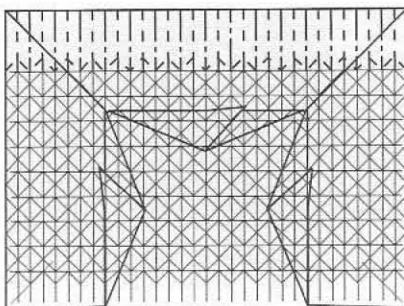

Reverse the mountain and valley folds as you valley-fold a row of diagonal creases.

65

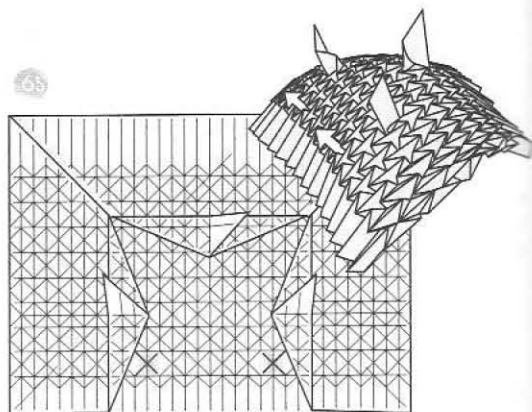

Reverse two waterbombs to form the eyes.

66

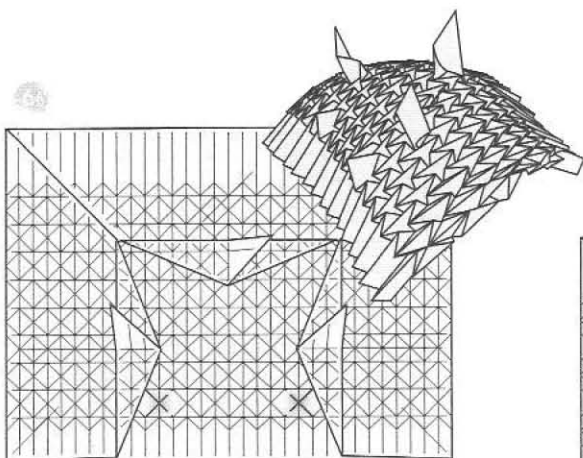

*Round the eyes. Dampening and using cotton balls for shaping is helpful.

67

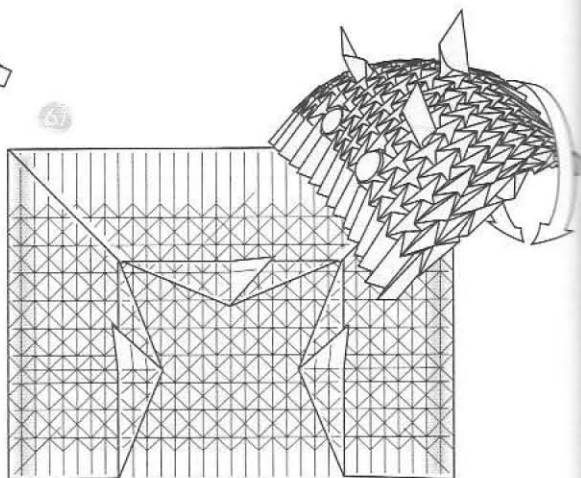

*Close the model by interlocking the last row of waterbombs on both edges of the paper. Use methyl cellulose to hold them together.

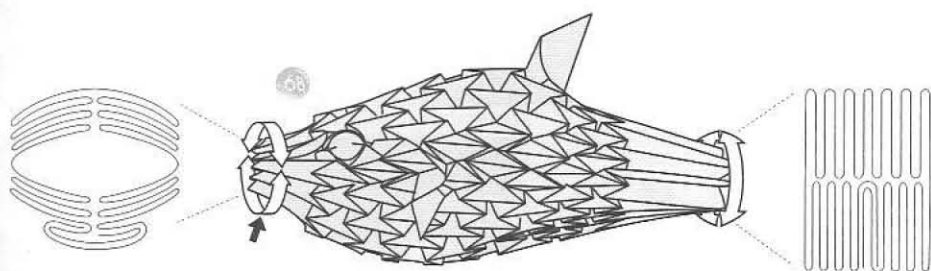

Distribute the layers of the mouth and tail. Squash the overlapping edges at the bottom of the mouth. The mouth should have an opening.

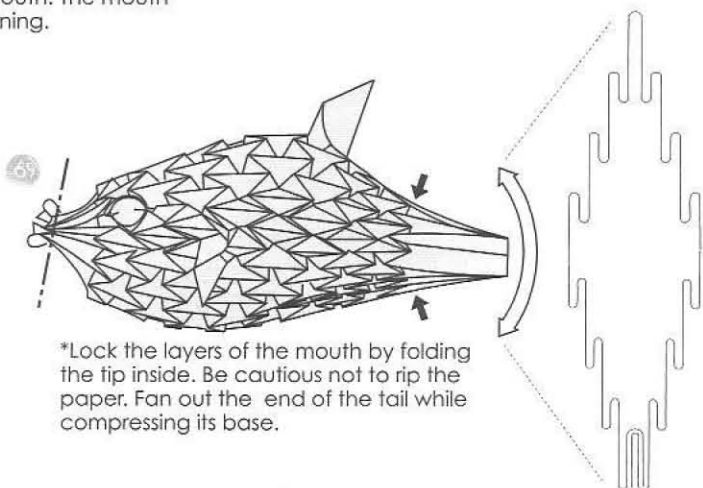

*Lock the layers of the mouth by folding the tip inside. Be cautious not to rip the paper. Fan out the end of the tail while compressing its base.

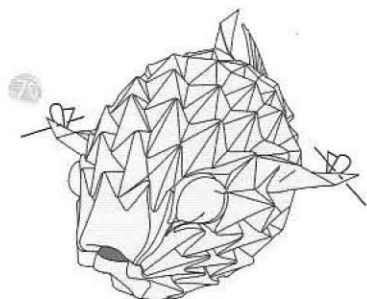

Fold the tips of the pectoral-fins inside.

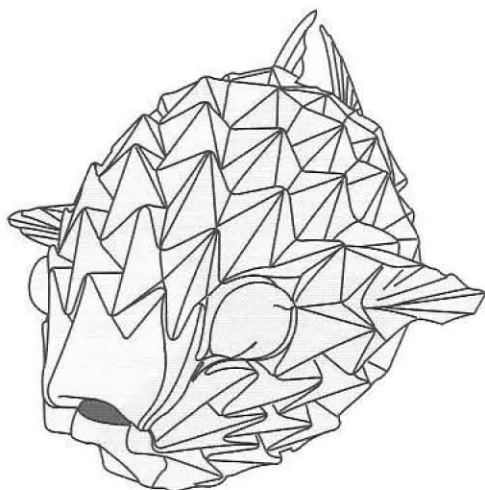
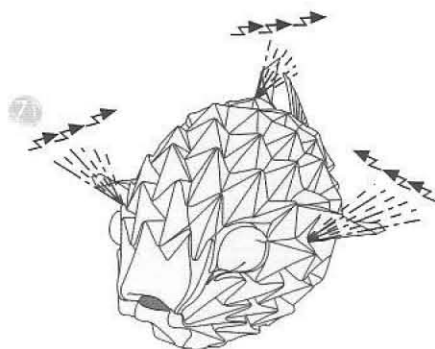

The completed Fugu is ready for puffing action! You can alter the Fugu's shape by blowing air into it or sucking air out of it.

My goal with this model was to design a Koi with a soft flowing shape, without omitting the dorsal fin. This model can be folded with paper weighing anywhere between 40-185 gsm. Best results are achieved by wet folding or finishing.

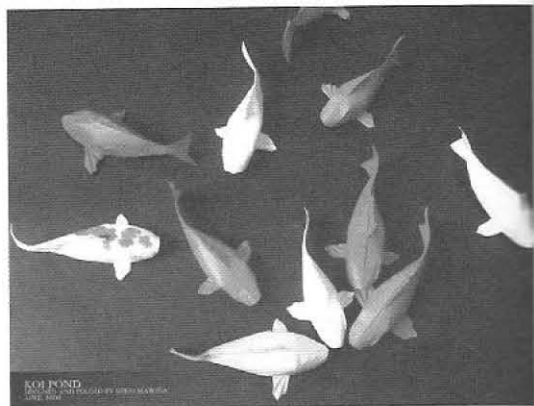
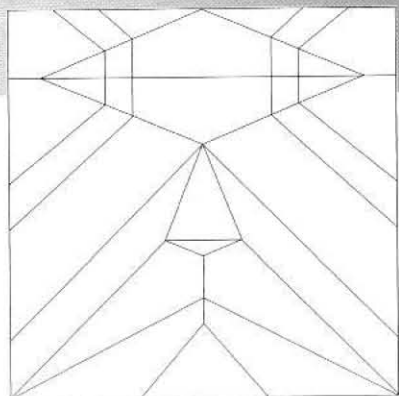

1

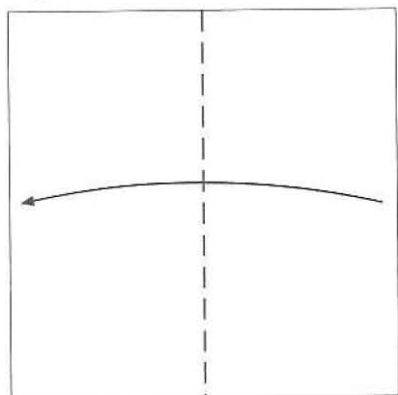

Fold the right edge to the left.

2



Fold the corner to the left edge. Unfold.

3

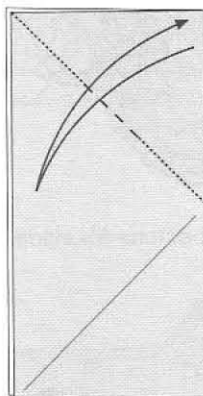

Fold the corner to the left edge. Unfold.

4

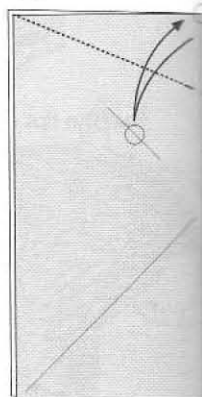

Fold the corner to the circled mark. Unfold.

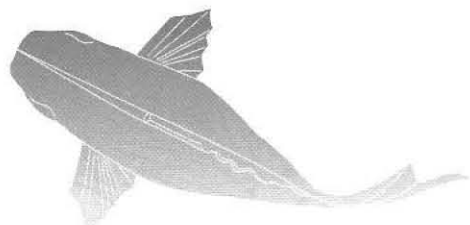

Japão Burajirujin
www.japaoburajirujin.blogspot.com

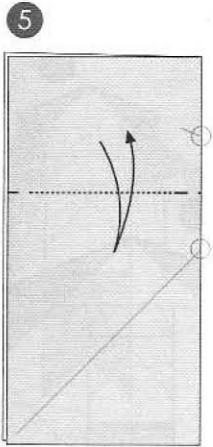

Align the marks. Unfold.

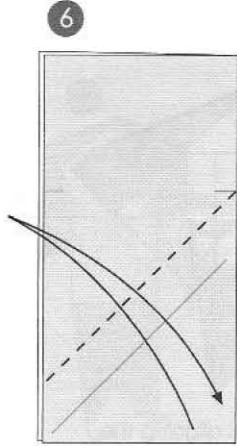

Align the right edge with the marks. Unfold.

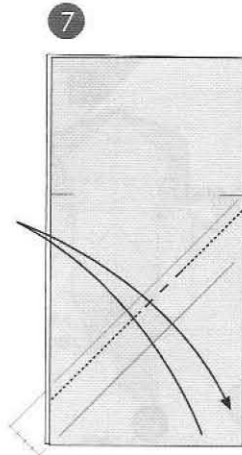

Fold 1/4 distance between the lines. Unfold.

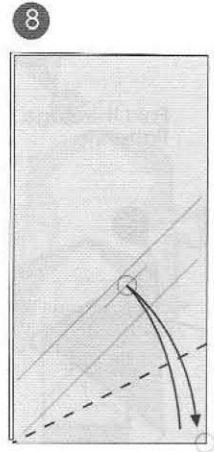

Fold the corner to the mark. Unfold everything.

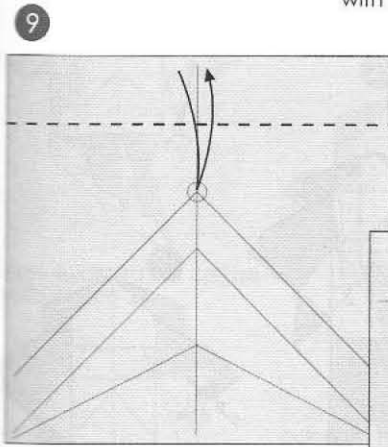

Fold the top edge to the marked point. Unfold.

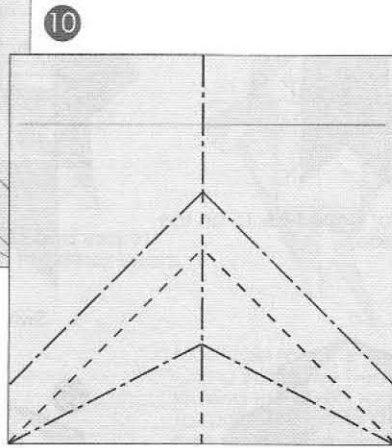

Collapse as indicated.

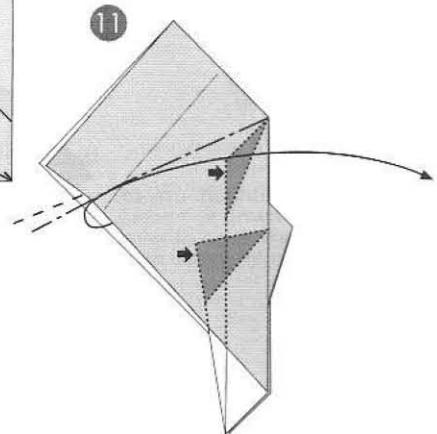

Swing the top layer to the right and spread squash together with the shaded areas.

Japão Burajirujin
www.japaoburajirujin.blogspot.com

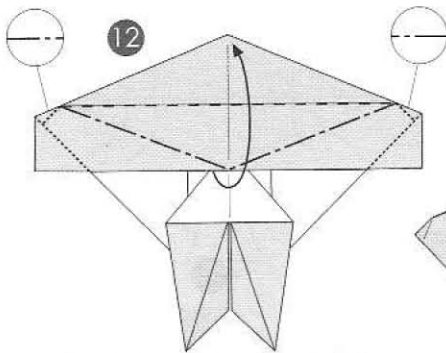

12
Fold the edge to the top and flatten.

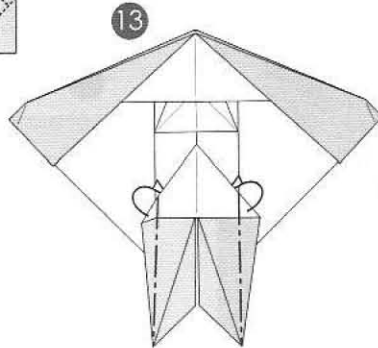

13
Mountain fold aligning the edges.

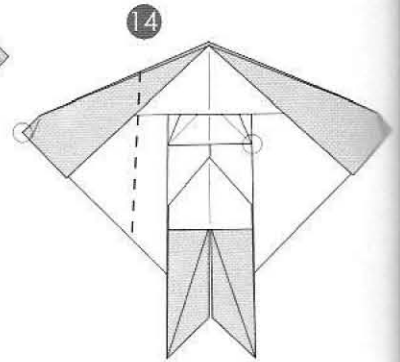

14
Fold the corner to the marked point.

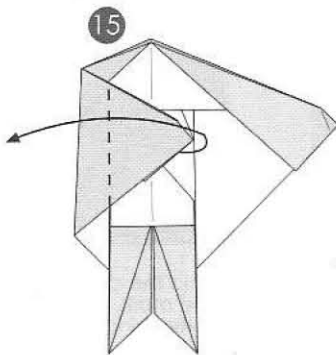

15
Fold to the left aligning it the crease with the lines beneath.

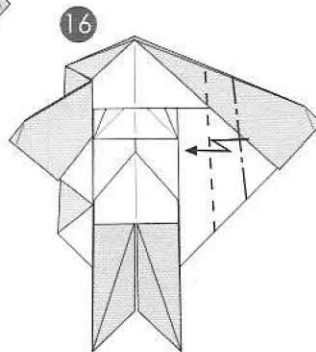

16
Repeat steps 14 & 15 on the right side.

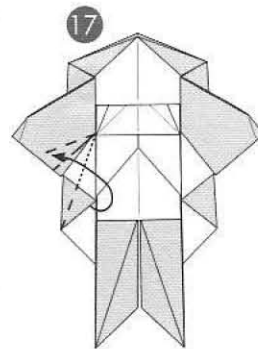

17
Swivel.

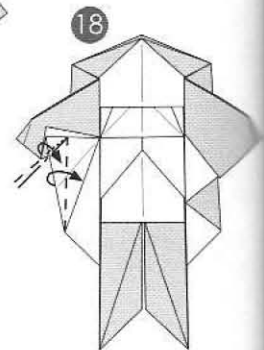

18
Swivel again.

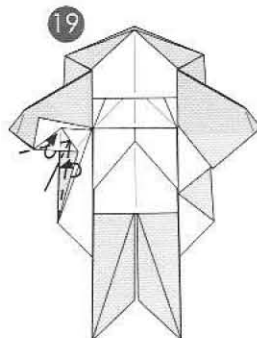

19
Swivel once more.

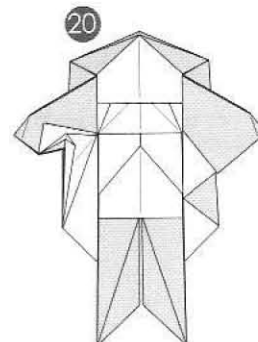

20
Repeat steps 17-19 on the right side.

Japão Burajirujin

www.japaoburajirujin.blogspot.com

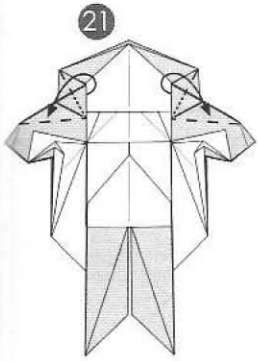

Swivel.

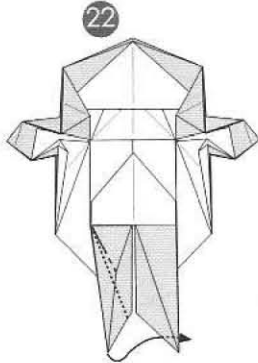

Inside reverse-fold.

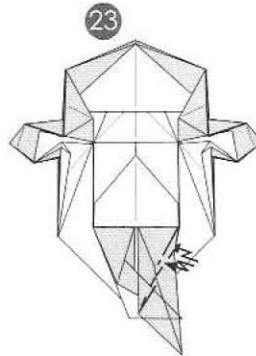

Crimp inside.

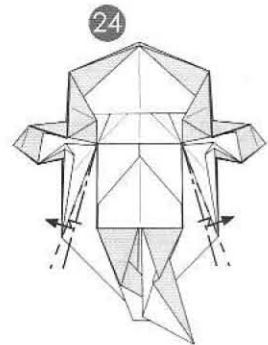

Crimp. The model will no longer lie flat.

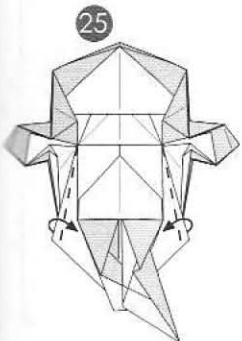

Valley-fold along the crease made in step 24.

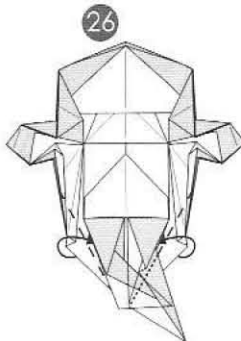

Fold inside and tuck in beneath the other layers.

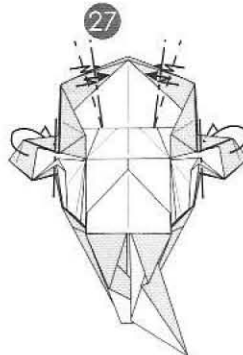

Mountain fold the pectoral fins. Crimp inside the head area locking the layers together. To make the crimp steps 15-21 can be undone.

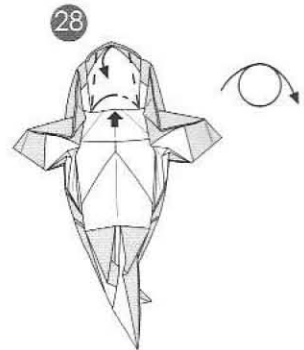

As you mountain fold the semi-circle pull down the top layer to open the mouth and form valley folds to narrow it

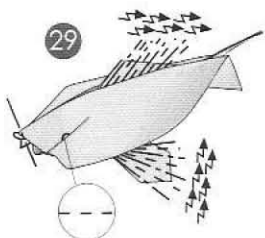

Shape the fins with crimps. Mountain fold the tip of the nose and shape the eyes and tail.

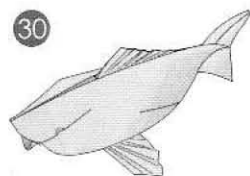

The finished Koi.

SEPIA

Alessandro Beber - Italy

model and drawings: july 2006

crease pattern:

paper: 20-25 cm square of sandwich paper.

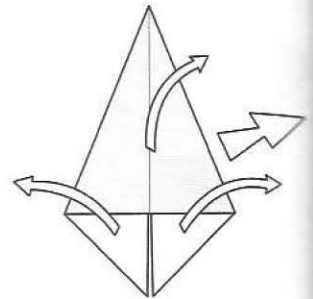
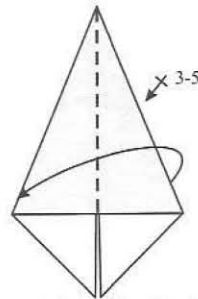
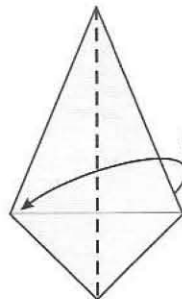
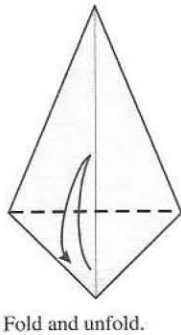
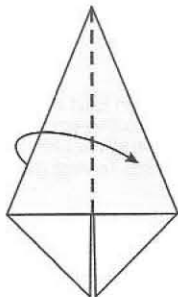
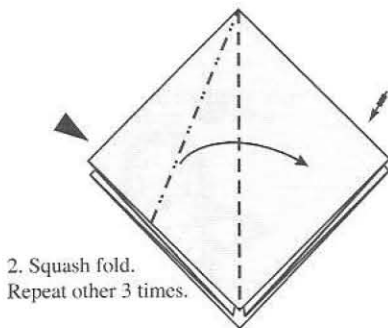
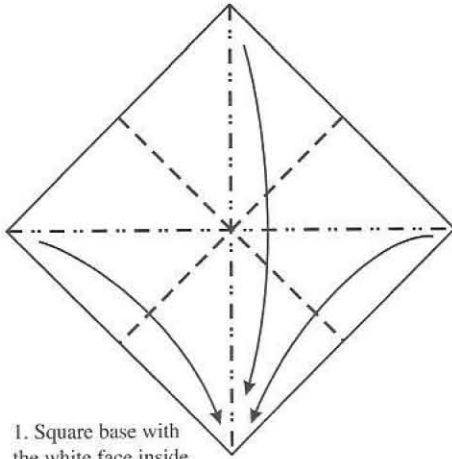
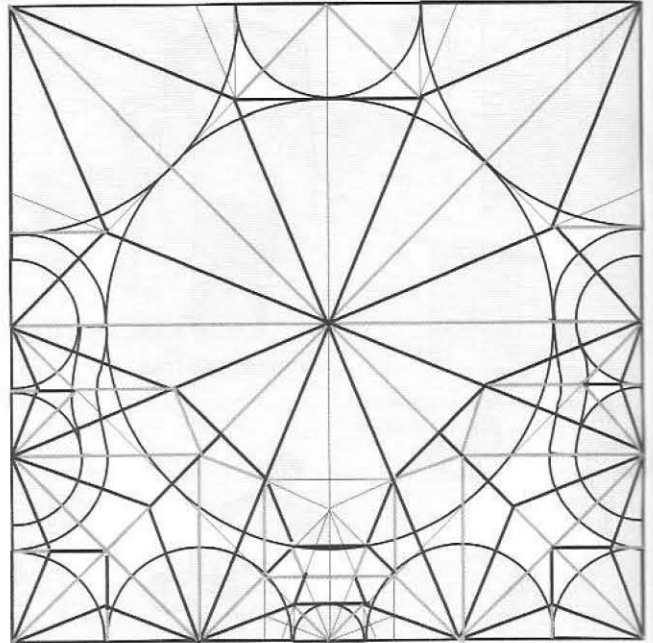

6. Repeat steps 3-5 on the right.

7. Unfold everything.

3. Valley fold one layer to the right.

4. Fold and unfold.

5. Fold one layer to the left.

8. Valley fold the 4 corners to the centre and unfold.

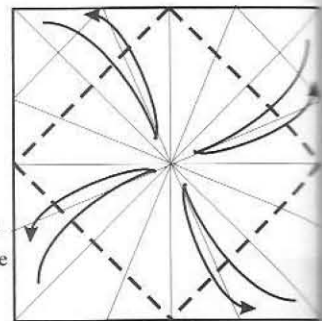

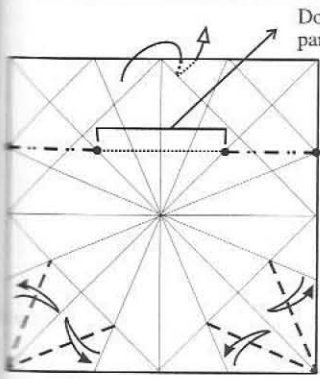

9. Fold and unfold. Then rotate.

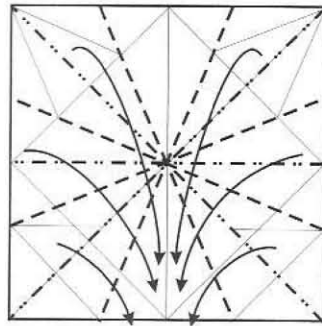

10. Refold like at step 3.

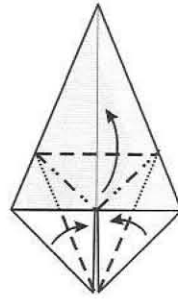

11. Petal fold on the existing creases.

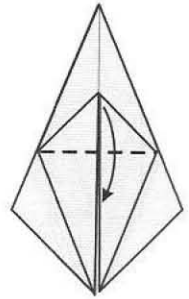

12. Fold the corner down.

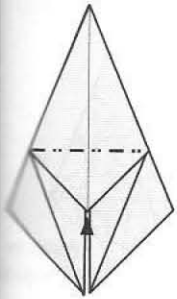

13. Sink the corner inside.

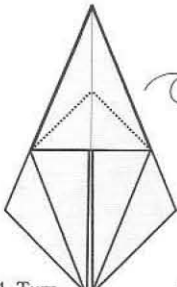

14. Turn the paper over.

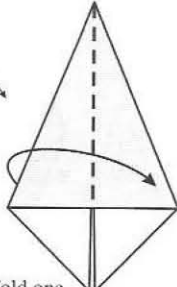

15. Fold one layer to the right.

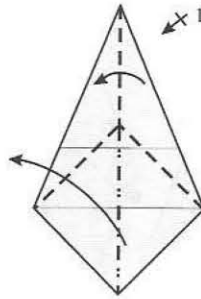

16. Inside reverse fold using the existing creases. Then repeat on the right.

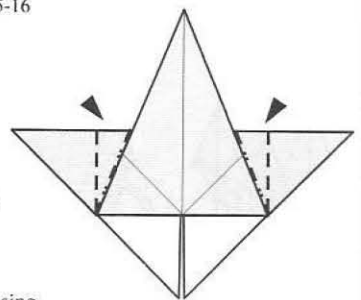

17. Crimp the 2 flaps.

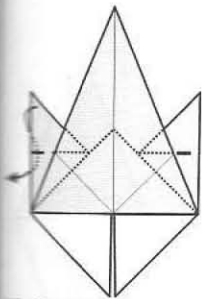

18. Reverse fold 2 flaps.

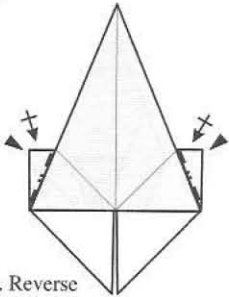

19. Reverse fold 4 corners.

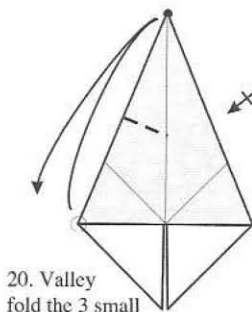

20. Valley fold the 3 small flaps to the upper corner and unfold. Then repeat on the right.

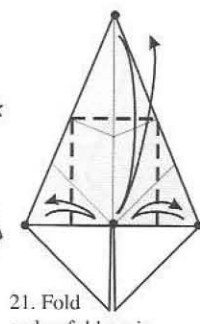

21. Fold and unfold again.

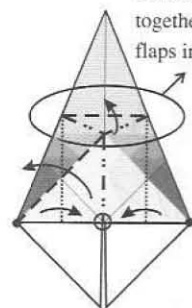

22. Bring the 2 circled corners to the centre with 2 valley folds (the 2 hidden folds)...

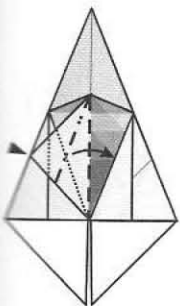

23. Like this. Squash fold the central flap.

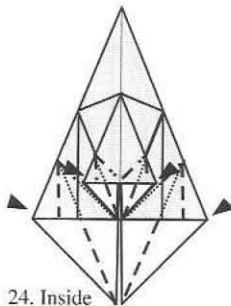

24. Inside reverse fold 4 corners.

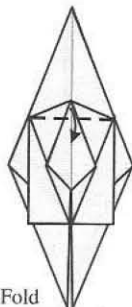

25. Fold the small flap down.

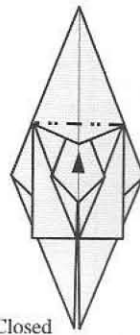

26. Closed sink the small flap inside.

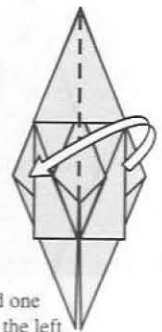

27. Fold one layer to the left releasing the trapped paper and squash.

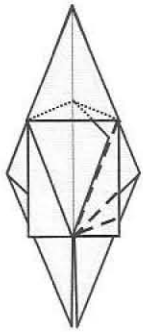

28. Fold and unfold in quarters.

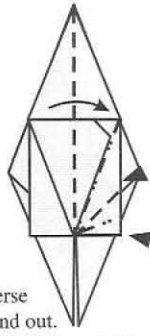

29. Reverse fold in and out. Then fold one layer to the right.

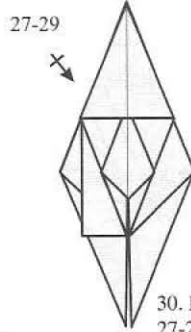

30. Repeat steps 27-29 on the left.

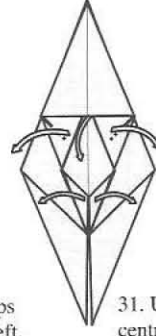

31. Unfold the central part.

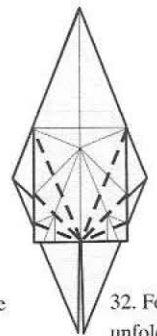

32. Fold and unfold.

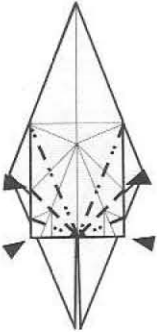

33. Reverse fold in and out.

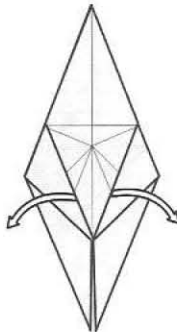

34. Unfold like at step 32

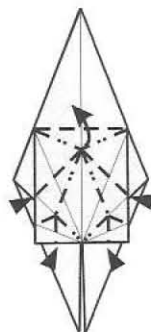

35. Refold the central part.



36. Unfold again and close using the existing creases of steps 31 and 33. Look next step to close the model.

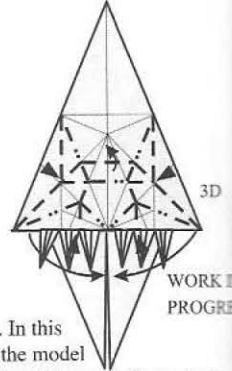

36A. In this step the model is 3D and there are showed all the creases you have to use to close the model...

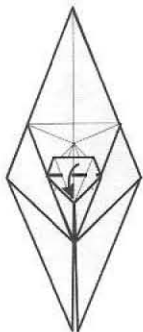

37. ...Like this. Valley fold the small flap down.

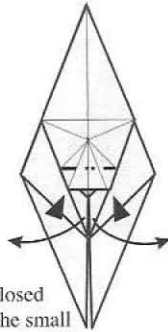

38. Closed sink the small flap. Unfold like at step 36A and look next step to close the model.

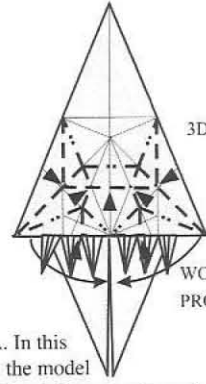

38A. In this step the model is 3D and there are showed all the creases you have to use to close the model...

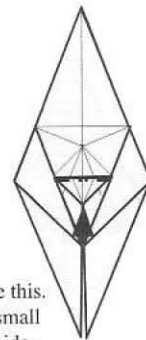

39. ...Like this. Sink the small corner inside. Then turn the model over.

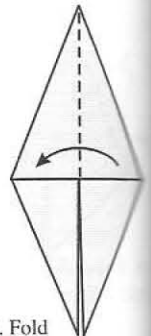

40. Fold one layer to the left.

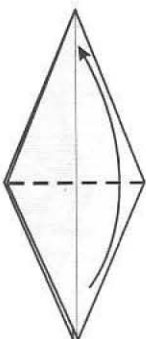

41. Valley fold the flap to the upper corner.

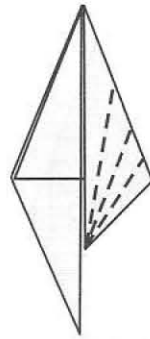

42. Fold and unfold in quarters.

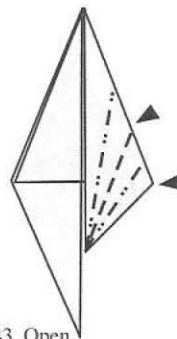

43. Open sink in and out.

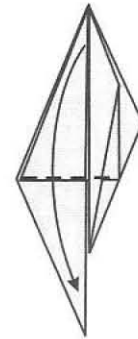

44. Fold the flap down.

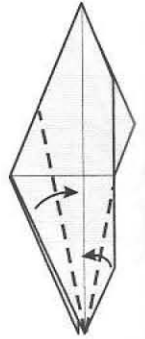

45. Valley fold along the bisectors.

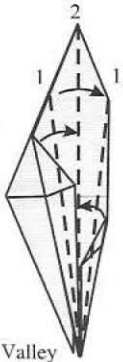

46. Valley fold along angle bisectors again. Then fold one

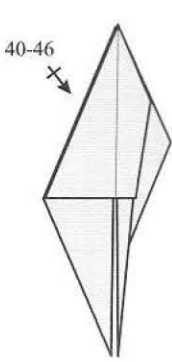

47. Repeat steps 40-46 on the left.

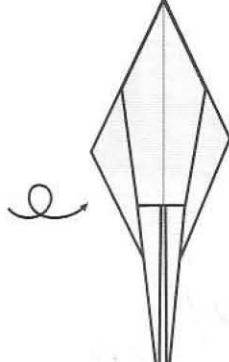

48. Turn the model over. layer to the right.

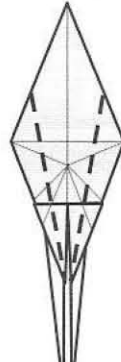

49. Valley fold along angle bisectors and unfold.

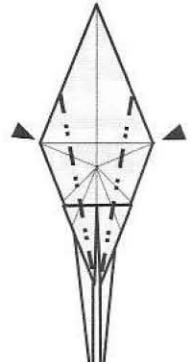

50. Closed sink the 2 corners.

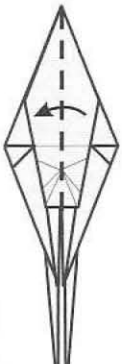

51. Valley fold one layer to the left.



52. Valley fold along angle bisector and unfold.

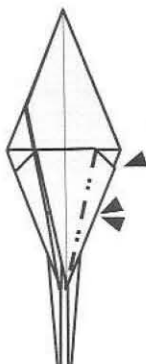

53. Open sink the 3 corners (the big corner and the 2 small hidden corners).

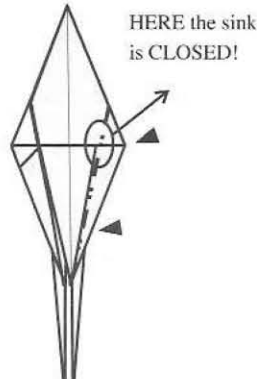

54. Open sink the bigger corner and the small hidden corner.



55. Valley fold one layer to the right.

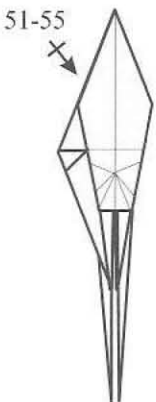

56. Repeat steps 51-55 on the left.

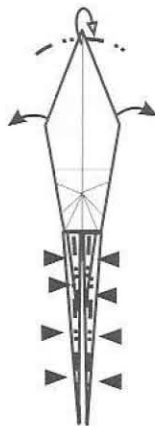

57. Shape the model like in the photo.

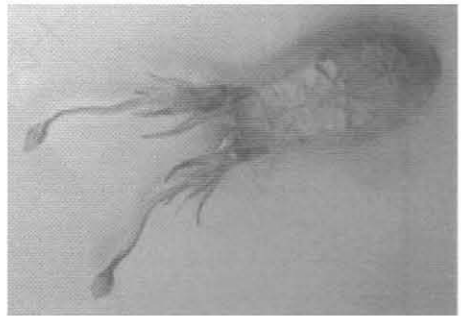

58. Completed sepia.

蟾蜍 Toad

創作及圖解：陳漢輝

creator & diagram : Jacky Chan
2008-06

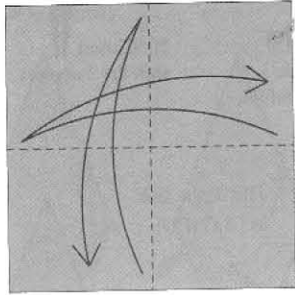
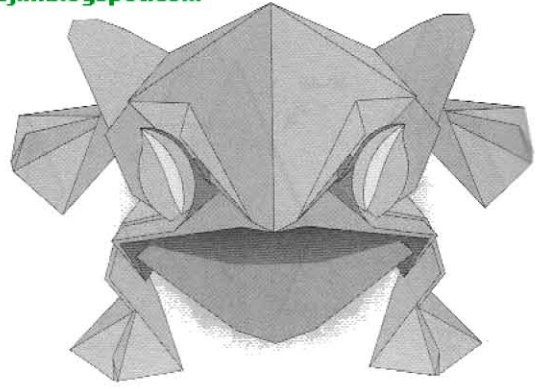

1

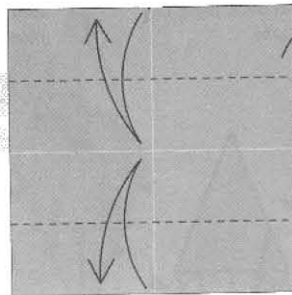

2

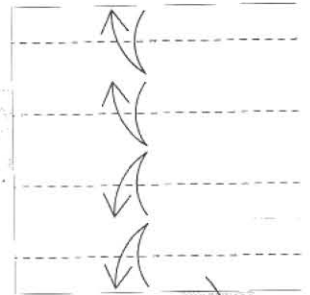

3

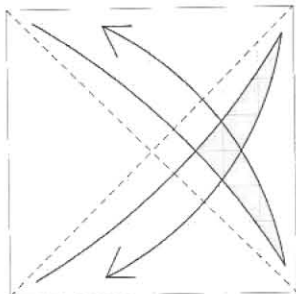

6

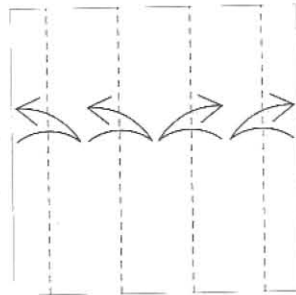

5

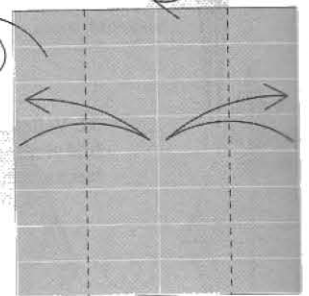

4

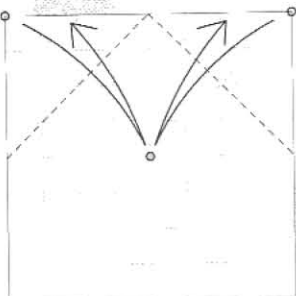

7

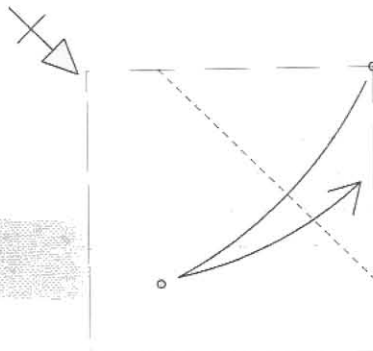

8

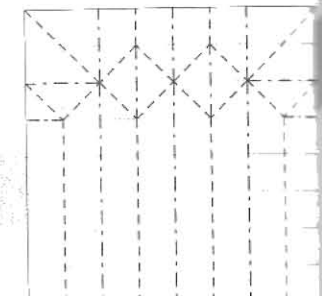

9

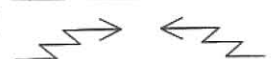

Toad by Jacky Chan

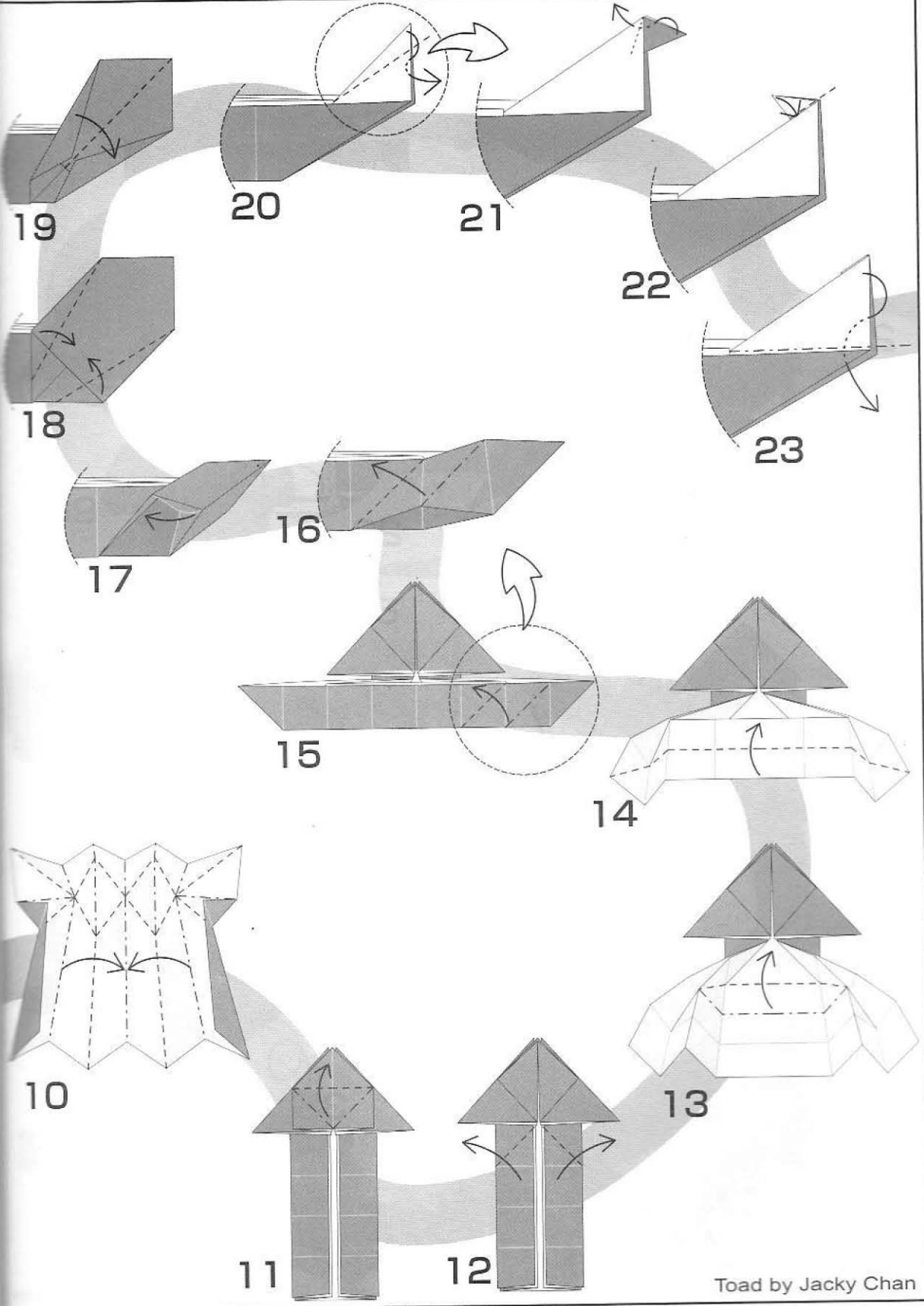

Toad by Jacky Chan

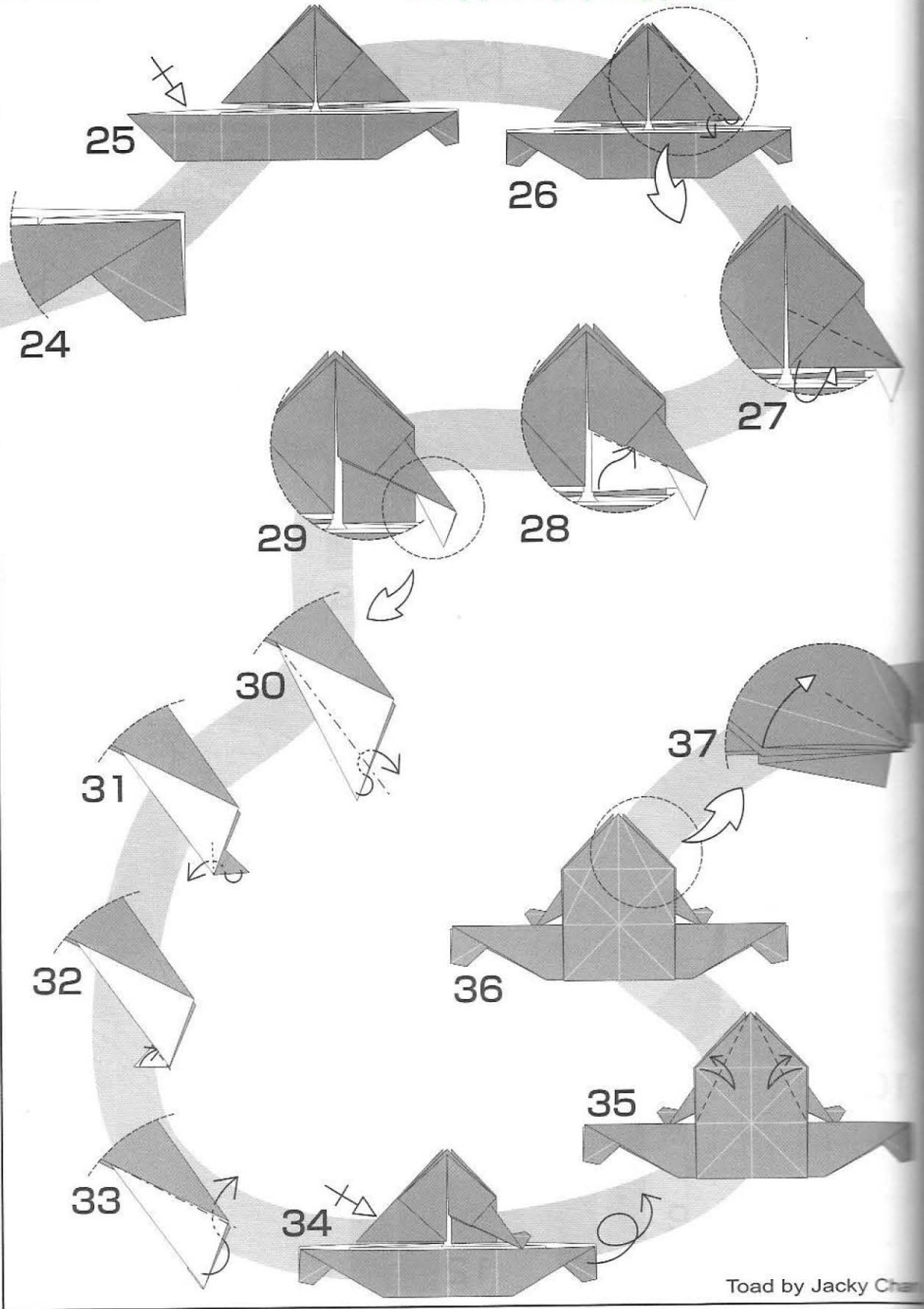

Toad by Jacky Chan

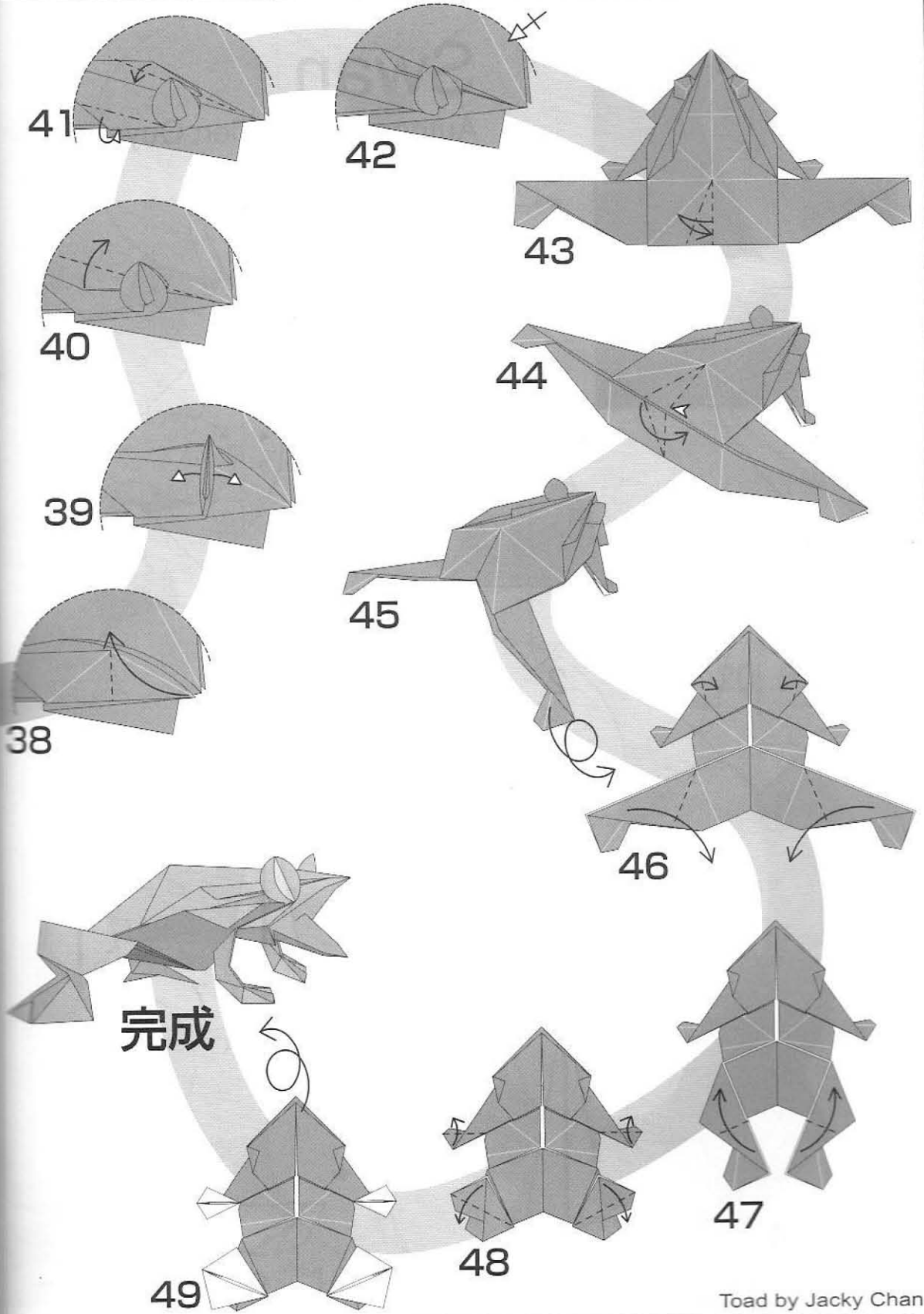

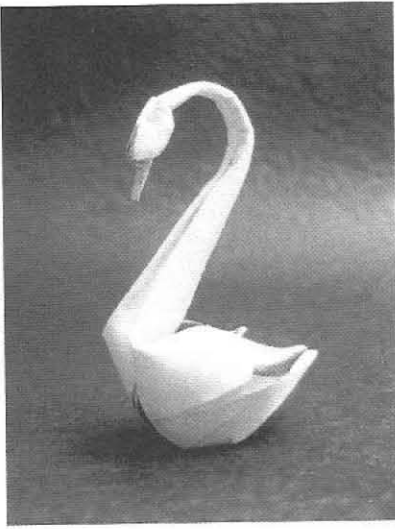

Swan

Author: Hoang Tien Quyet

Model: 2008/04

Diagram: 2008/06

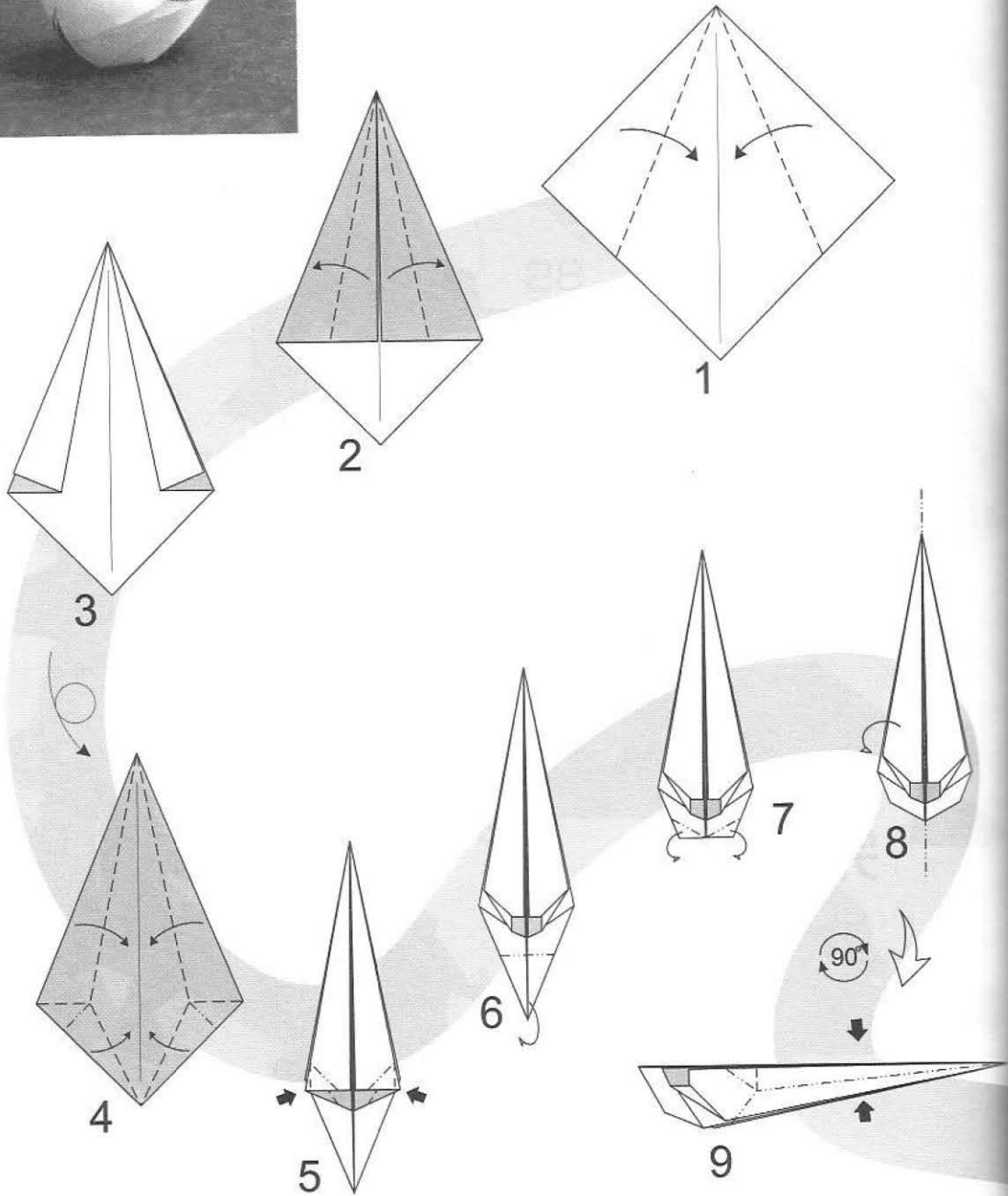

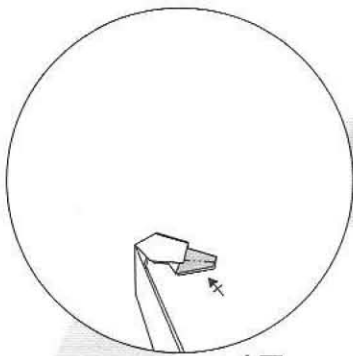

17

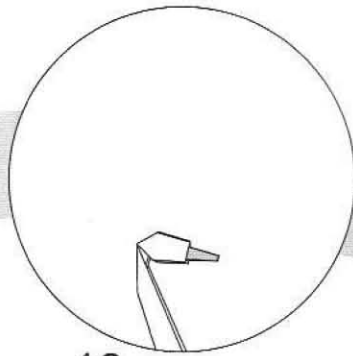

18

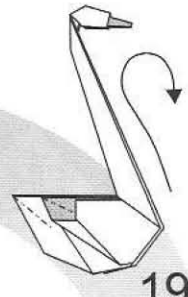

19

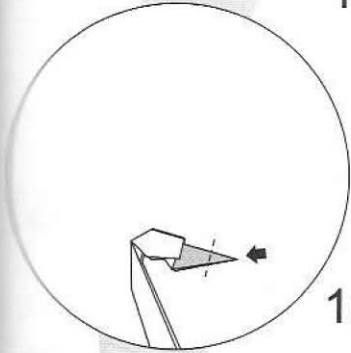

16

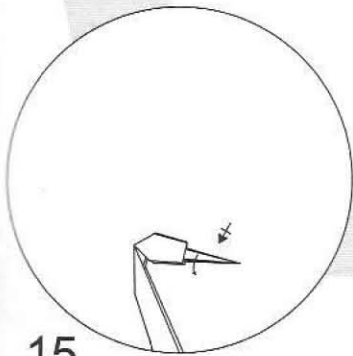

15

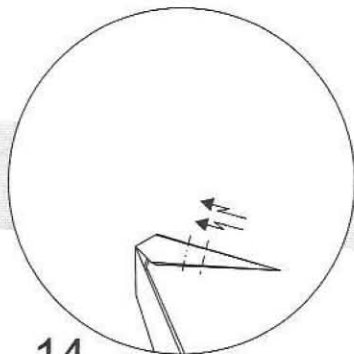

14

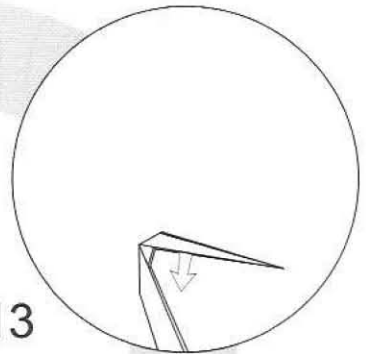

13

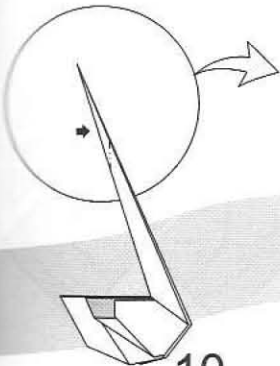

10

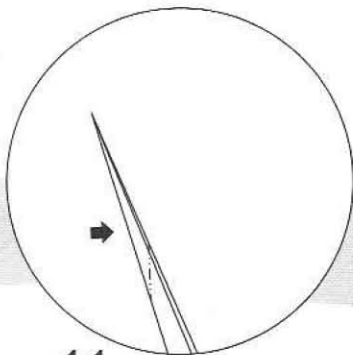

11

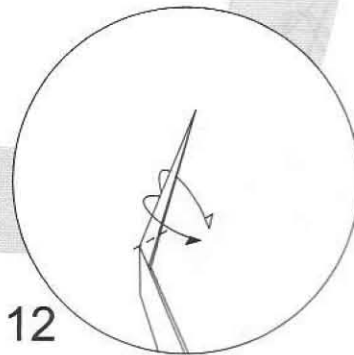

12

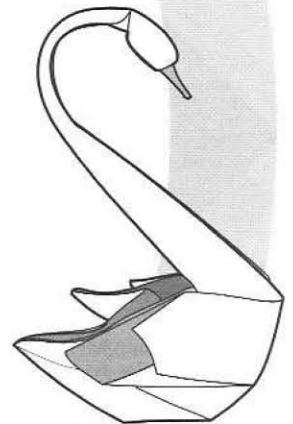

20. Finished

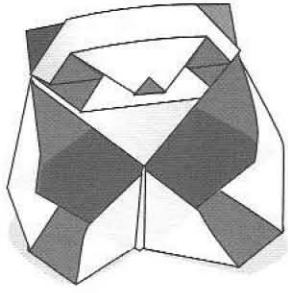

PANDA

Román Díaz

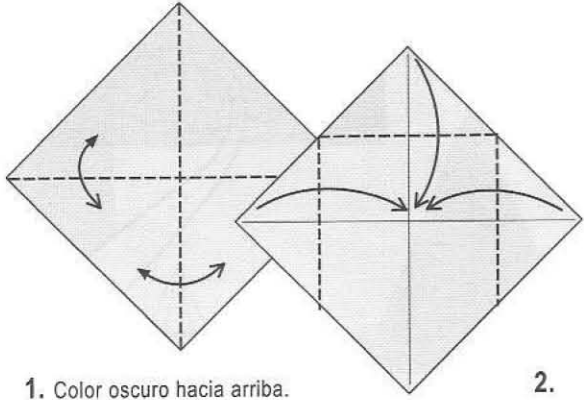
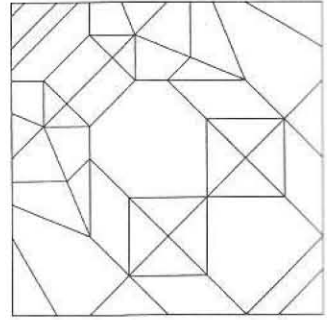

1. Color oscuro hacia arriba.
Dark color side up.

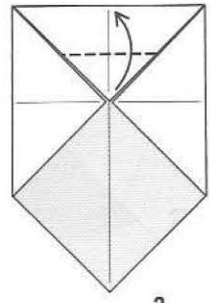

3.

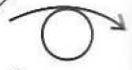
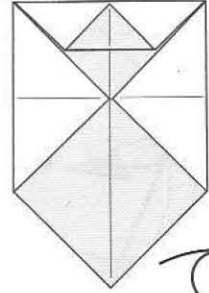

4.

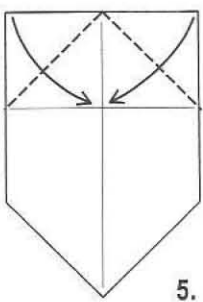

5.

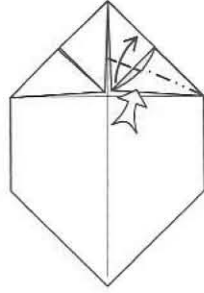

6.

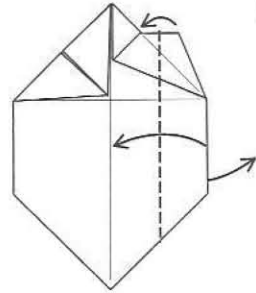

7.

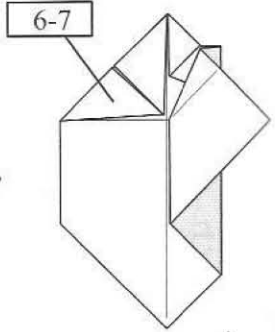

8.

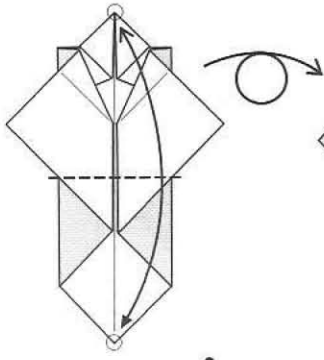

9.

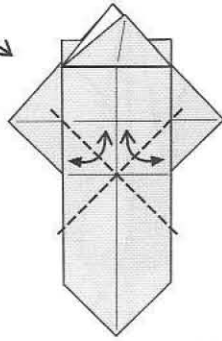

10.

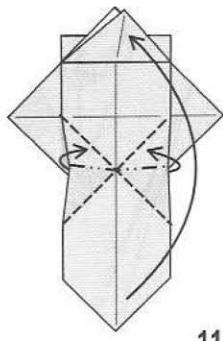

11.

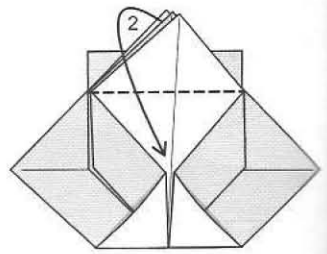

12.

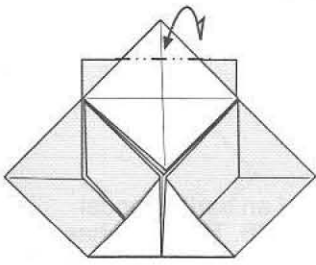

13.

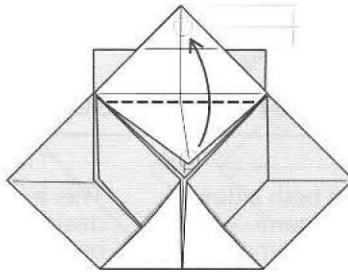

14.

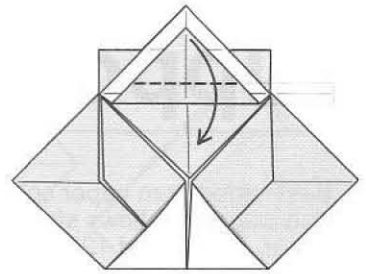

15.

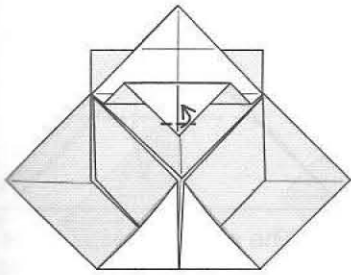

16.

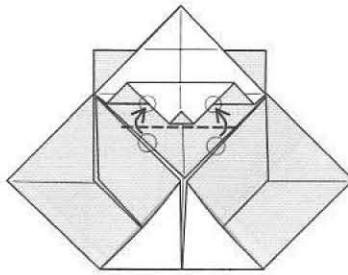

17.

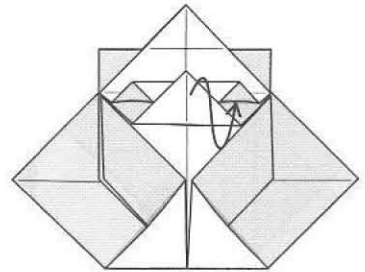

18.

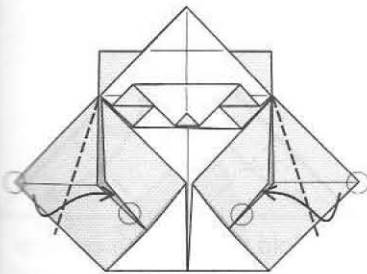

19.

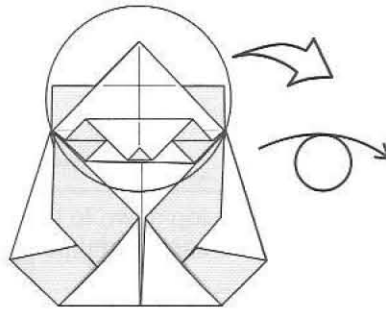

20.

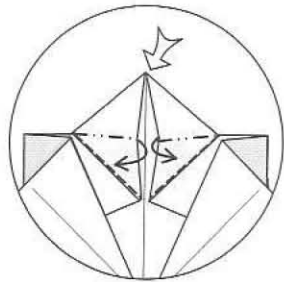

21.

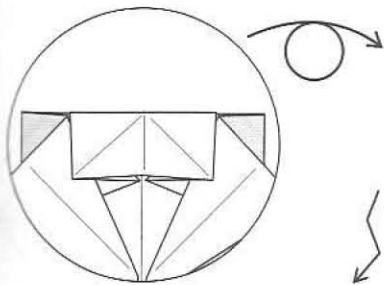

22.

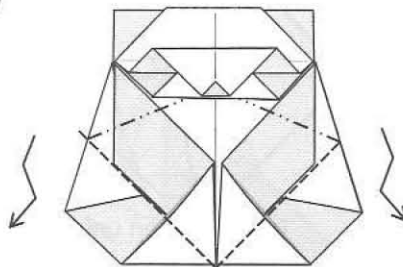

23.

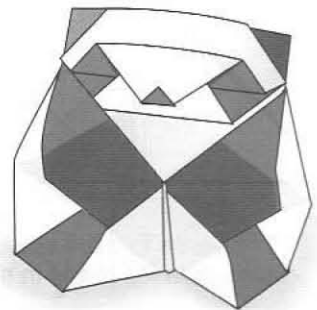

24.

Hippo

by Steven Casey

Best folded from paper coloured both sides
 The diagrams shows standard origami
 paper. A weight of 120 gsm is recommended.

This a revision of an earlier model
 designed circa 1978. The body has
 been made longer and the head
 is finished differently.

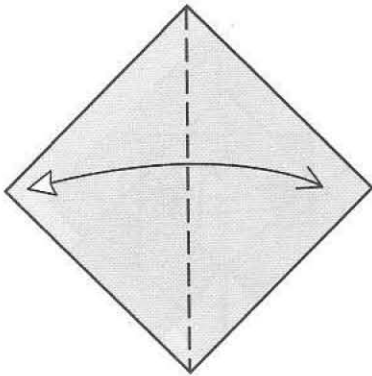

1. Fold left to right and unfold.

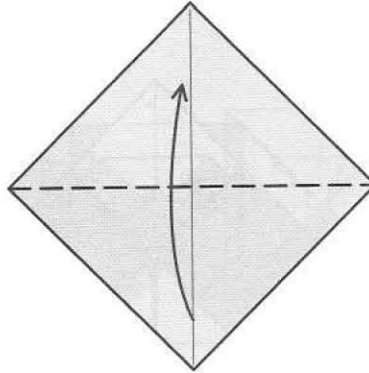

2. Fold bottom corner to the top.

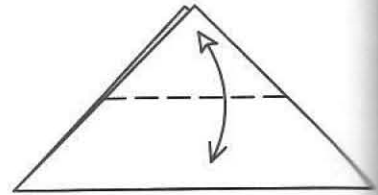

3. The next few steps focus on the upper layer only. Fold the top to the bottom and unfold.

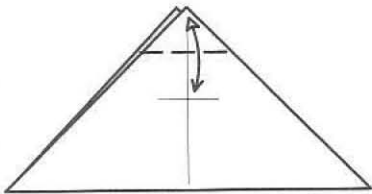

4. Fold the top down to the previous crease and unfold.

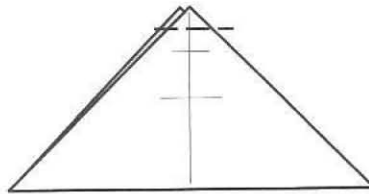

5. Fold the top down to the previous crease and unfold.

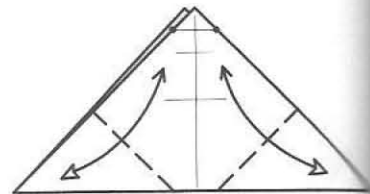

6. Fold the the side corners up to meet the points joined by the top crease. Unfold.

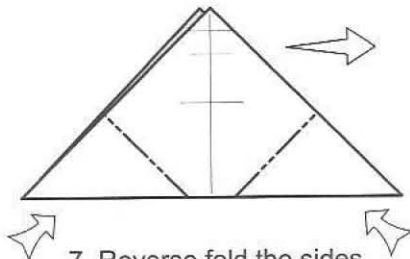

7. Reverse fold the sides using creases made in step 5.

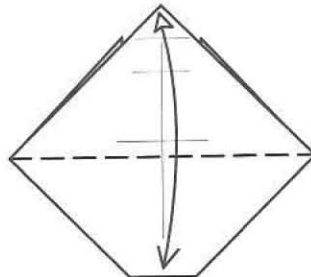

8. Valley then unfold.

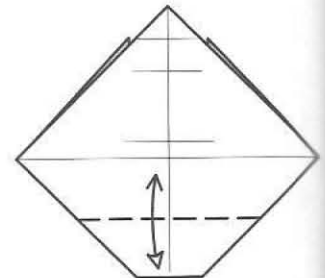

9. Valley then unfold.

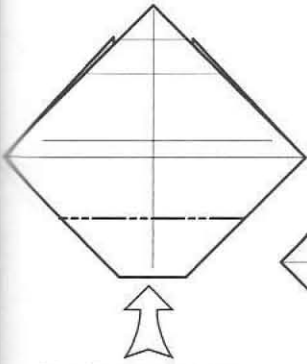

10. Open sink the bottom.

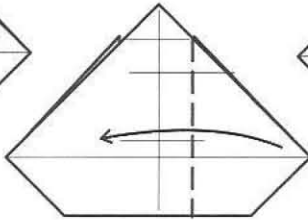

11. Fold single flap over.

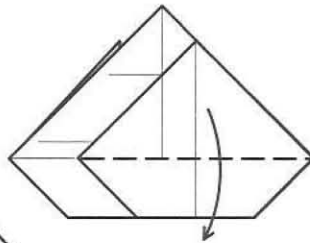

12. Fold single flap down.

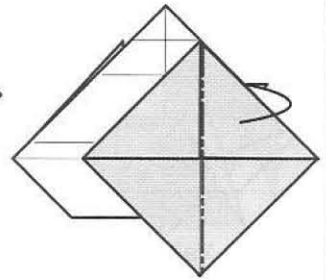

13. Fold Flap behind.

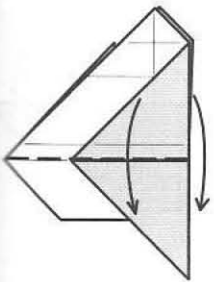

14. Fold single flap down in front and behind.

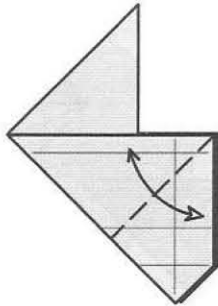

15. Fold side edge up to the folded edge. Unfold. Repeat behind.

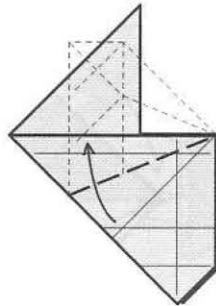

16. Fold the new crease in line with the folded edge. Repeat Behind.

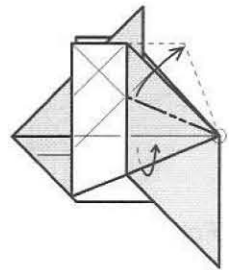

17. Pull out trapped layers and reposition. Repeat behind.

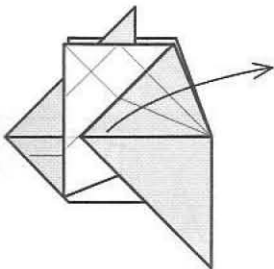

18 Fold flap upward.

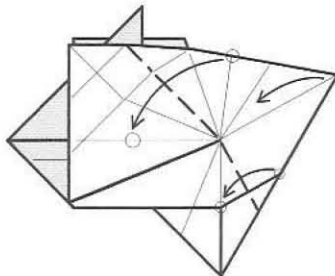

19. Fold on existing creases.

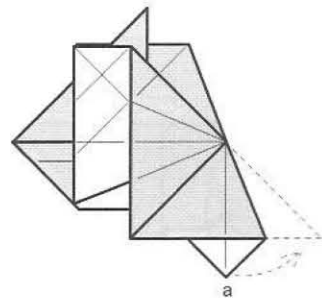

20. Repeat step 17 behind. Point a goes to the side.

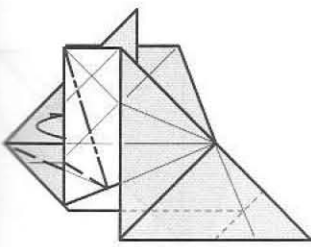

21. Swival. Repeat behind.

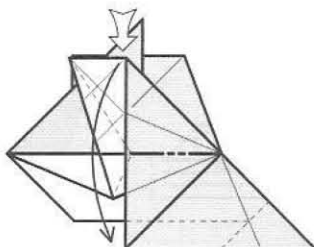

22. Reverse fold. Repeat behind.

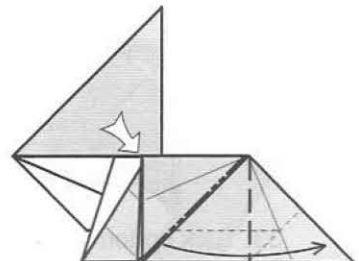

23. Valley and Squash. Repeat behind.

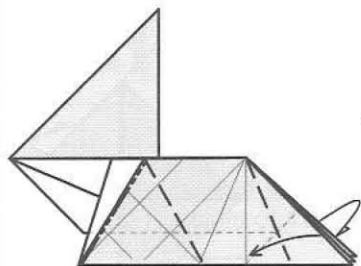

24. Valley small flap in front and behind.

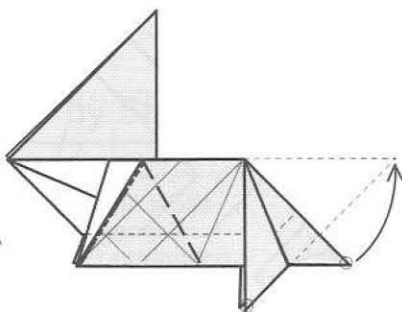

25. Pull middle point upward and release trapped layers.

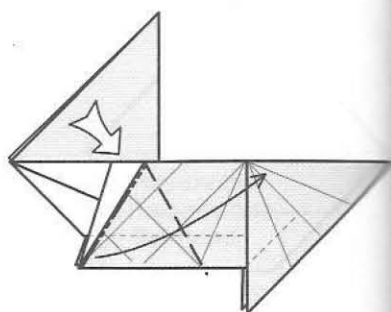

26. Squash fold in front and behind.

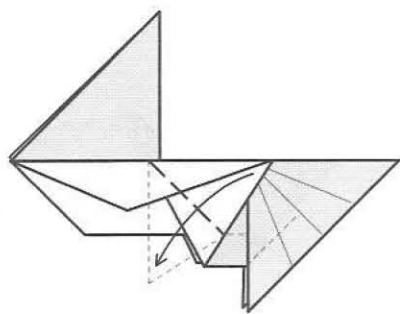

27. Fold side flaps down in front and behind.

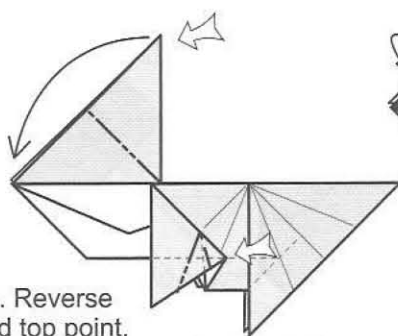

28. Reverse fold top point. Swivel side layers (both sides).

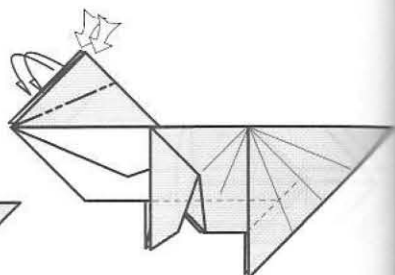

29. Reverse fold two corners.

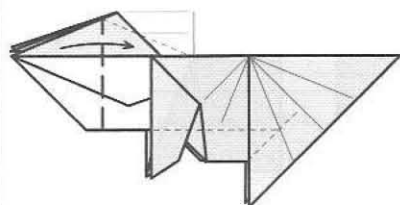

30. Valley flap inwards. Repeat behind.

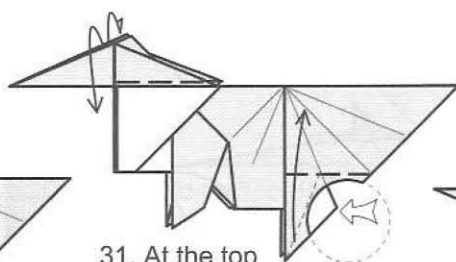

31. At the top of the model fold the flaps down in front and behind. Below lift the leg flap up toward the top, under the layers do a petal fold. Repeat behind.

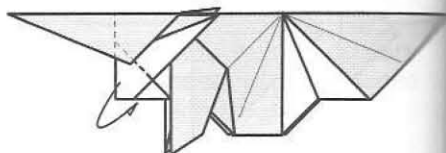

32. Tuck flap inward. Repeat behind.

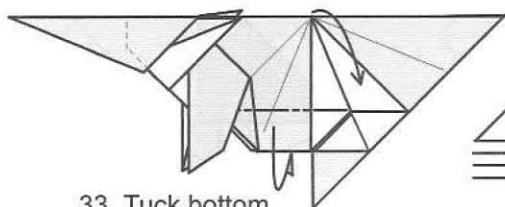

33. Tuck bottom flap under the first pocket and let the near flap flip downward. Repeat behind.

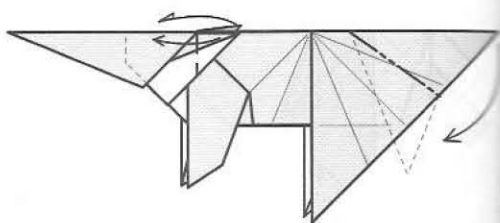

34. Valley ear flaps forward. Reverse fold tail down.

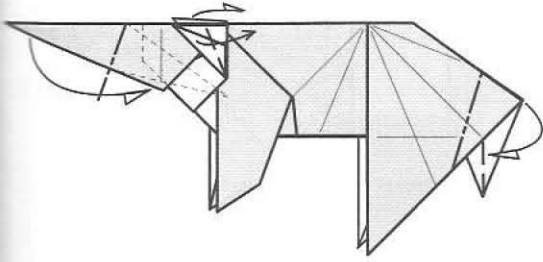

35. Reverse fold tip of head.
Swival fold tail section.
Valley ears away from head.

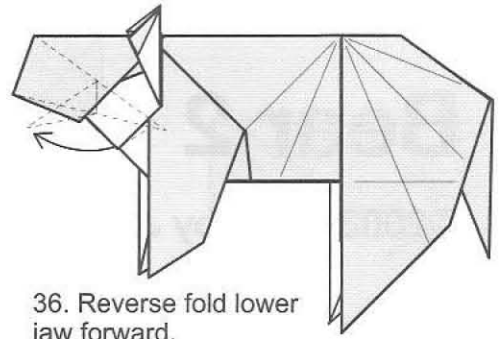

36. Reverse fold lower
jaw forward.

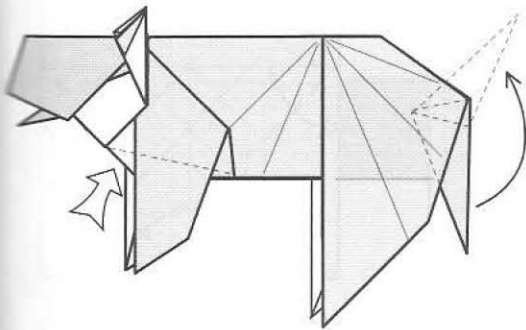

37. Open Sink underneath.
Reverse fold tail upward.

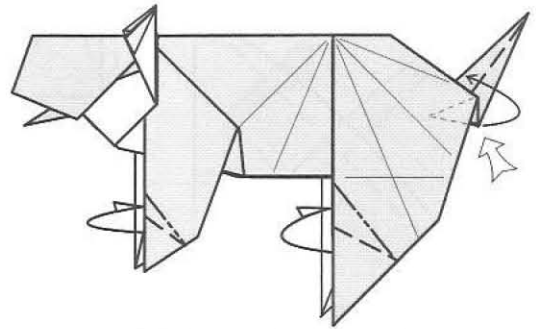

38. Narrow tail. Crimp leg
flapsto form feet. Next step
shows a slight rotation.

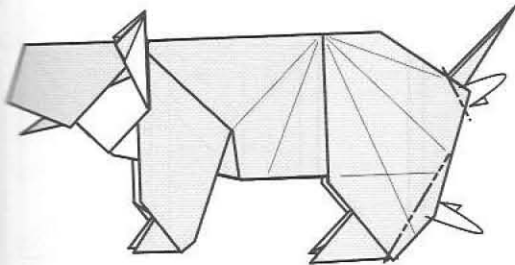

39. Shape rear section.
Repeat behind.

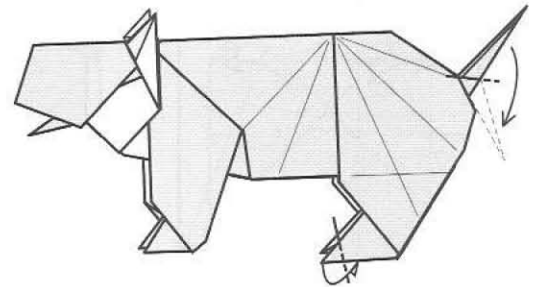

40. Reverse fold tail and
blunt back feet.

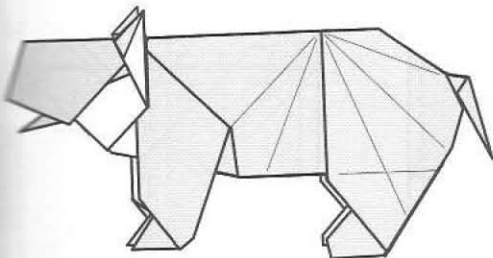

41. This shows the model folded
from papercoloured both sides.

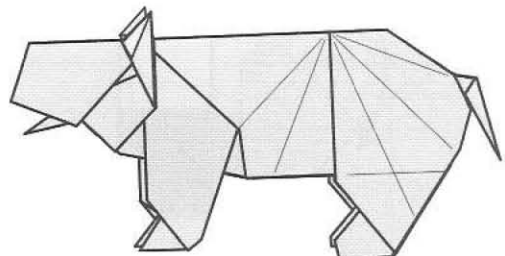

42. Complete.

Bear 2

©2003-2008 by Jared Needle

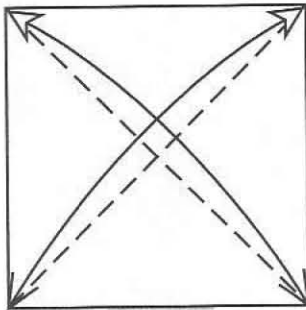
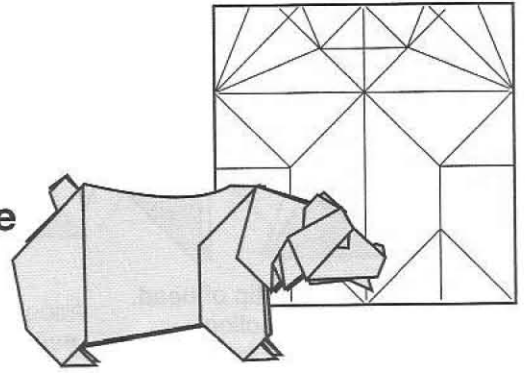

1

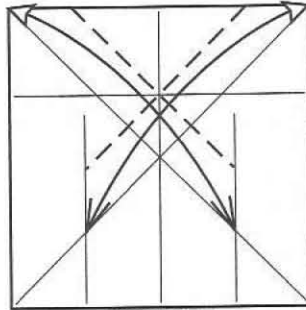

6

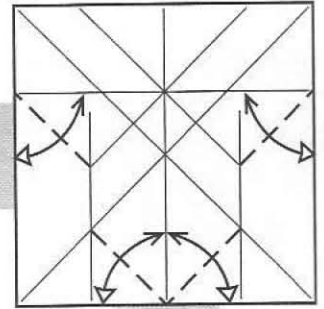

7

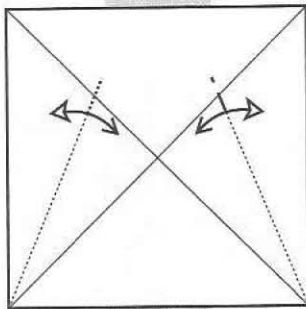

2

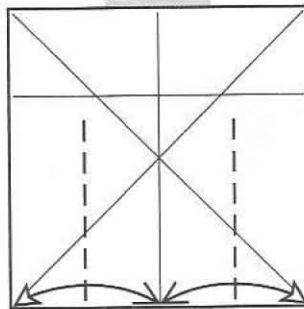

5

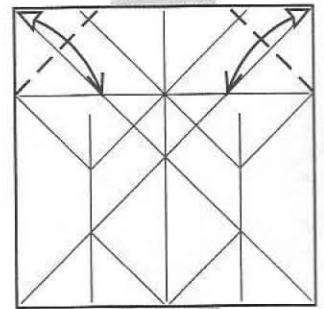

8

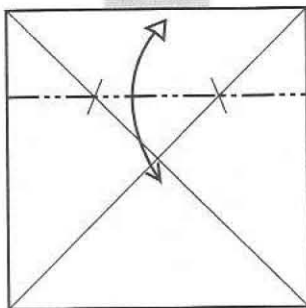

3

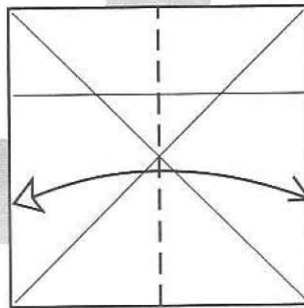

4

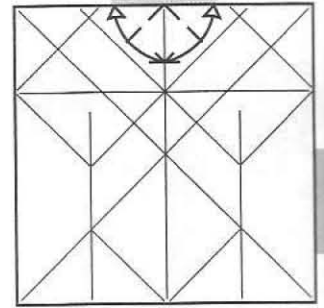

9

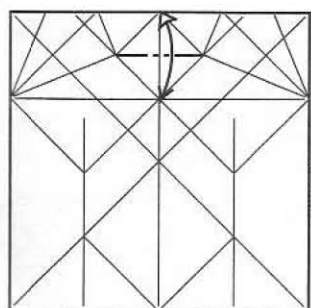

13

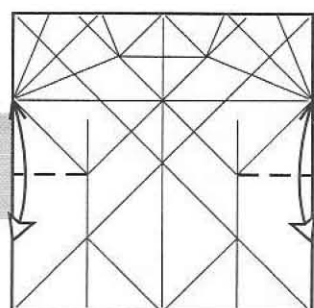

14

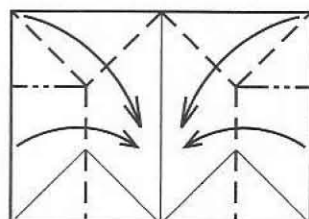

21

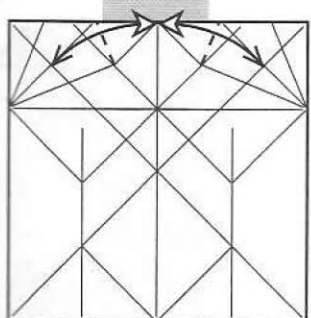

12

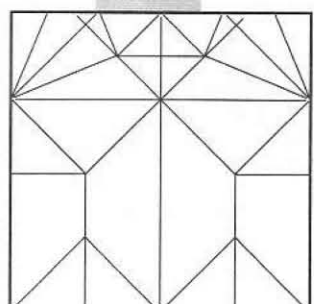

15

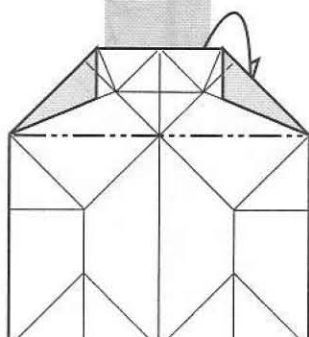

20

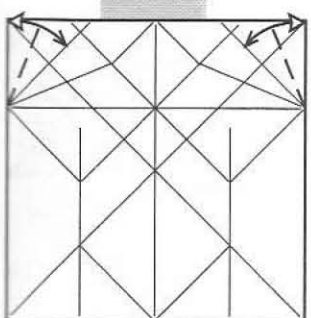

11

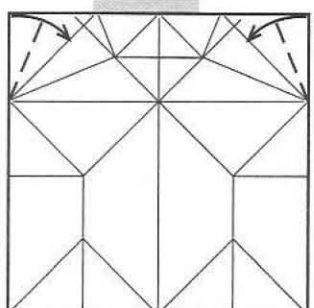

16

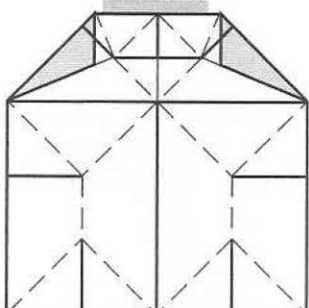

19 The crease pattern, if you want to skip to step 26

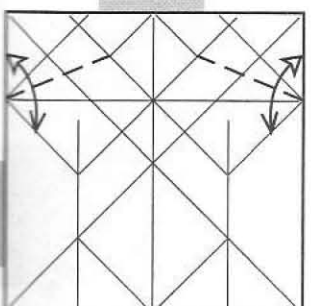

10

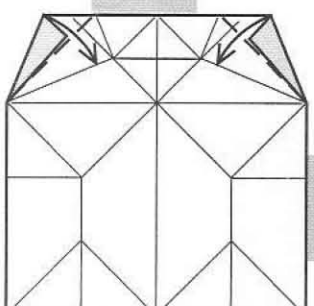

17

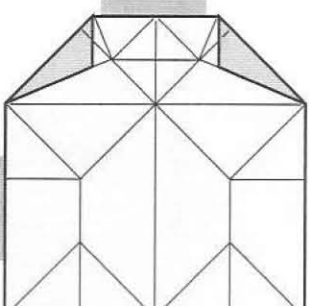

18

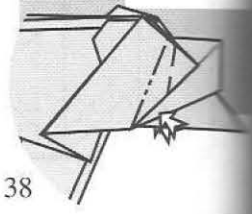
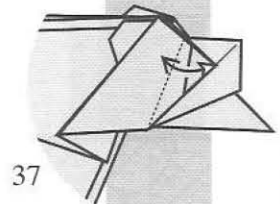
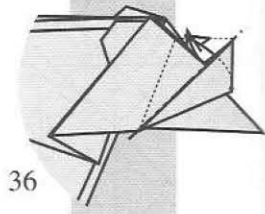
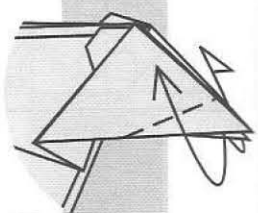
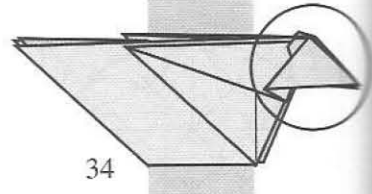
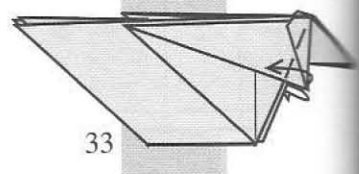
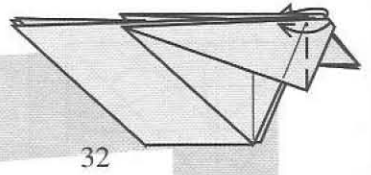
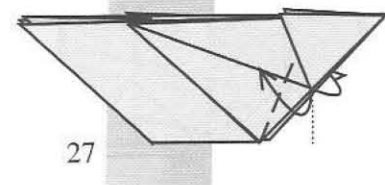
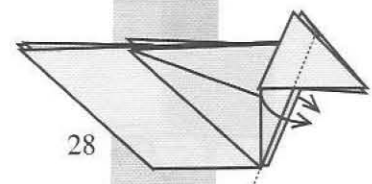
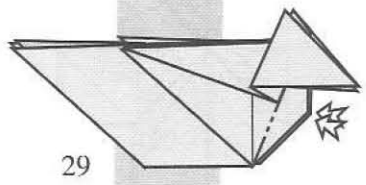
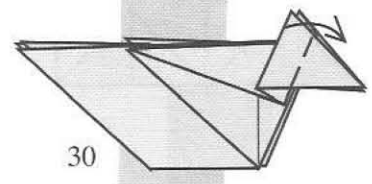
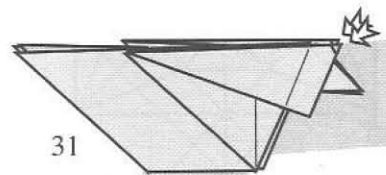
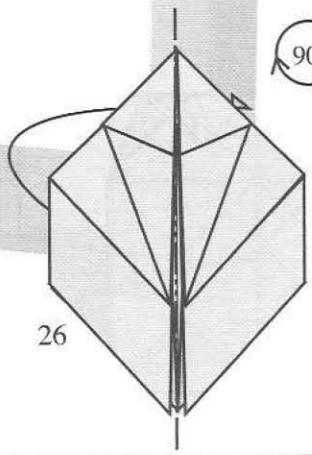
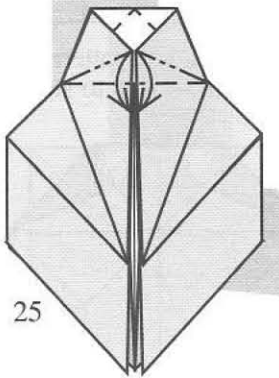
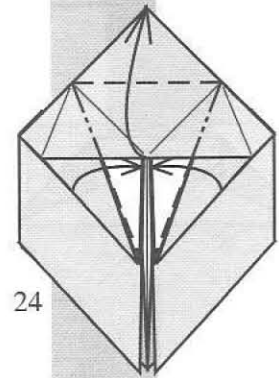
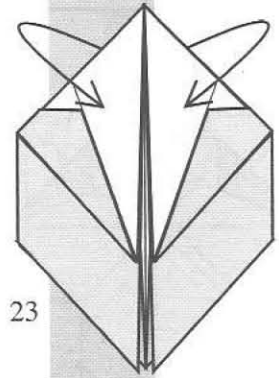
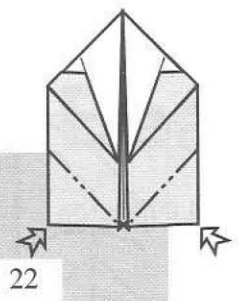

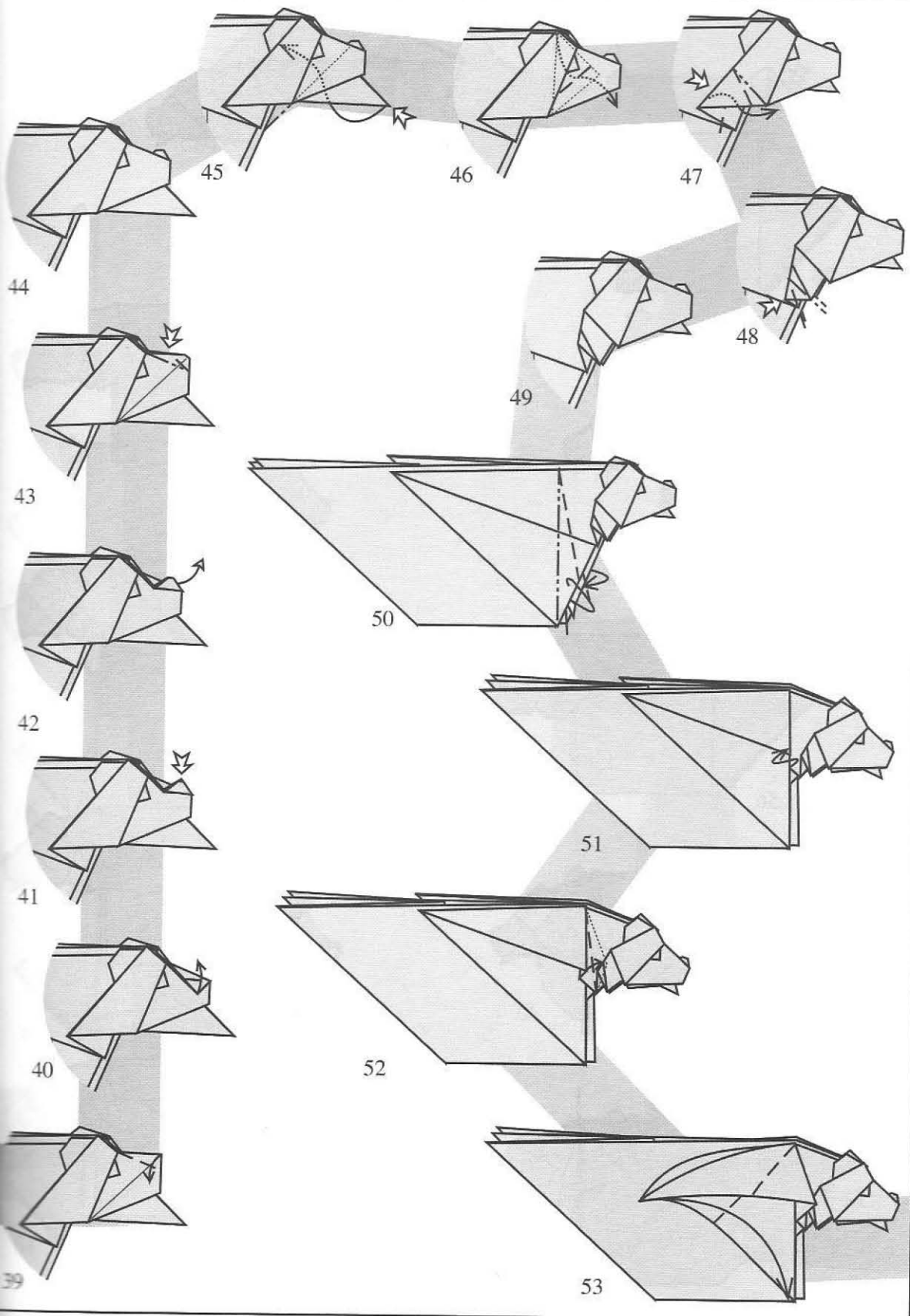

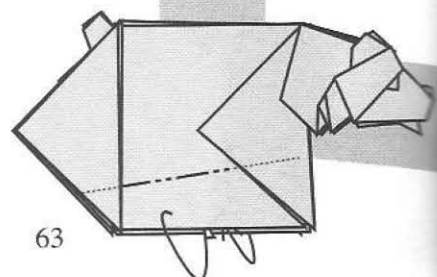
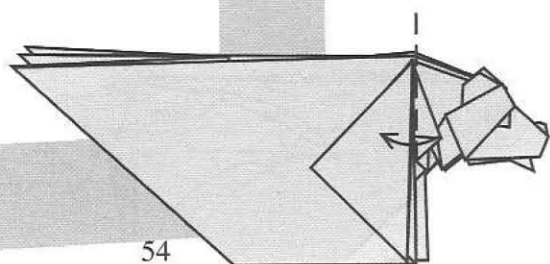
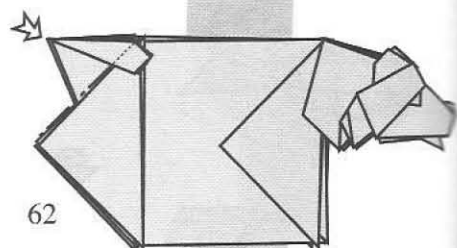
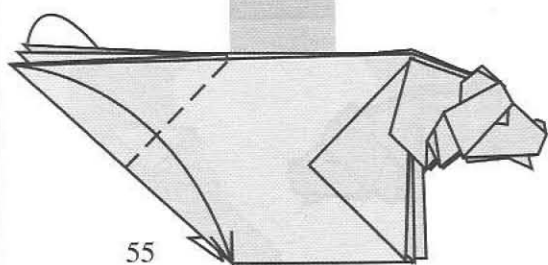
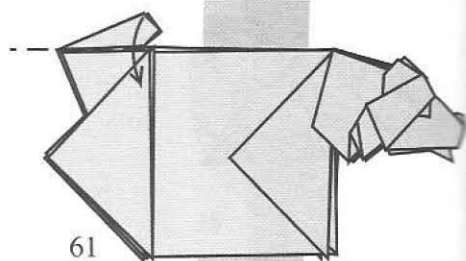
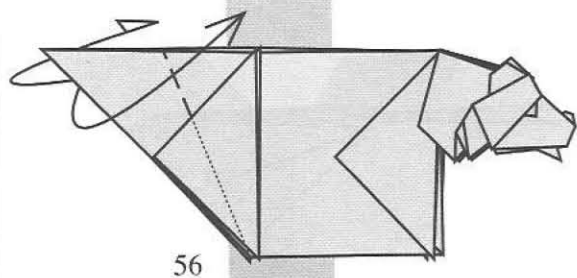
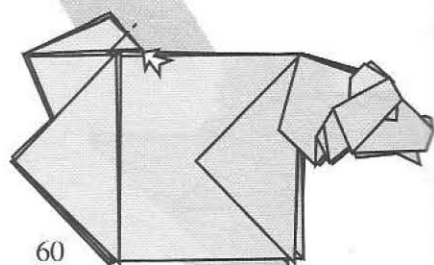
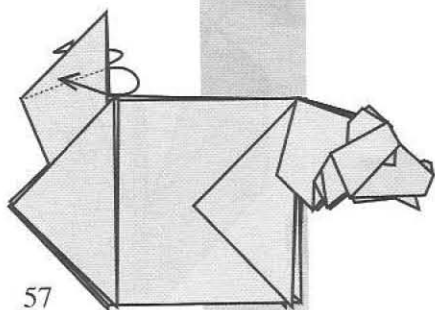
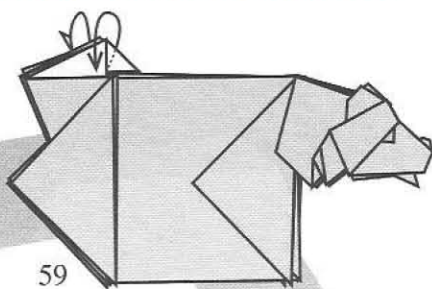
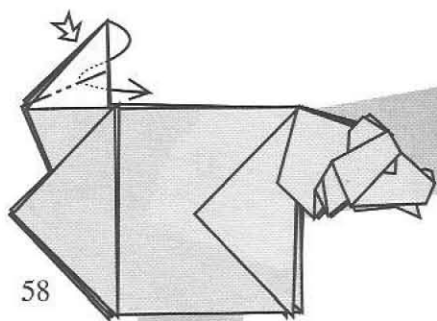

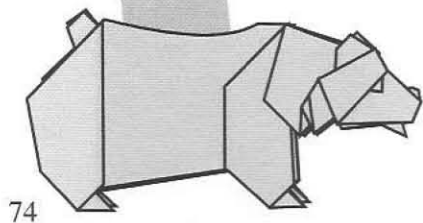
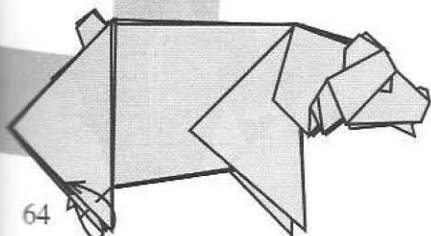
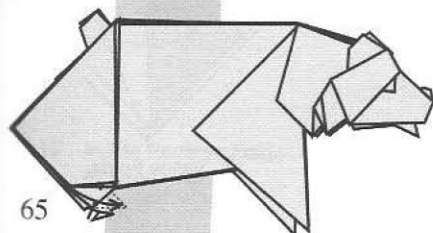
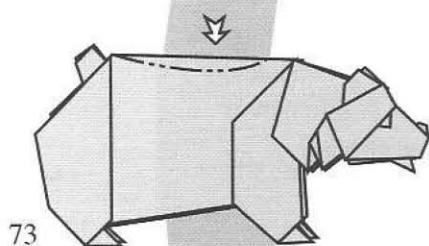
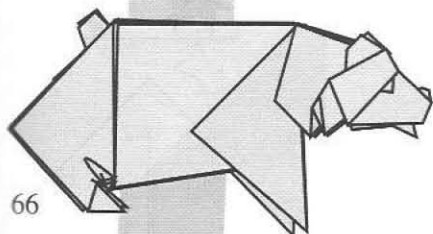
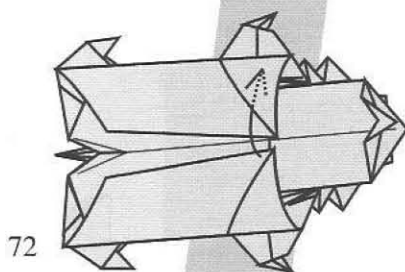
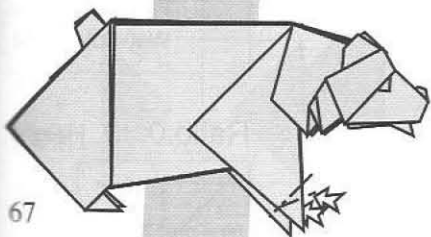
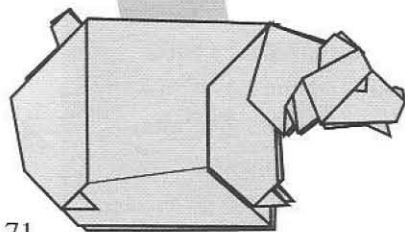
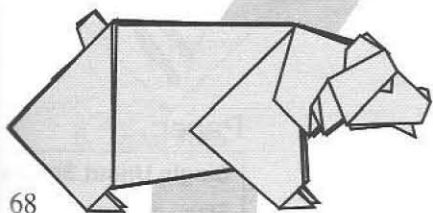
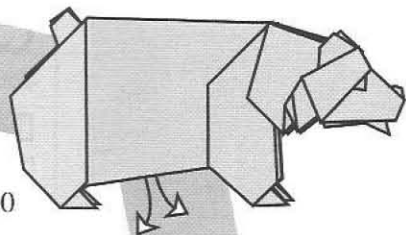
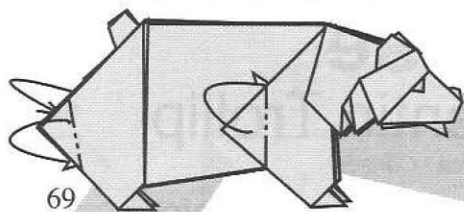

Horse Quentin Trollip

South Africa / Canada

Design and diagram info:

Date: 19 Sept 2007
 Difficulty: Complex
 Time to fold: 1 Hour

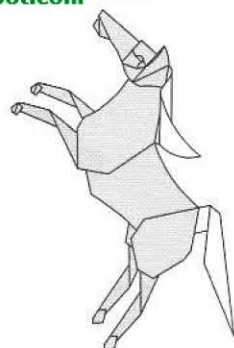

A horse is a difficult subject in origami. It has a bulky body and thin legs with many joints. It is also difficult to capture the gracious movement of this great animal.

The only real complex part in folding the Horse, is the Open Sink to form the mane in steps 63 to 67. I like this manoeuvre, as it yields a colour-changed mane which is not formed from the raw edges of the paper! The colour-change to the tail was added later to match the hair of the mane.

It is possible to pose the Horse in different postures, and multiple Horses together in different positions make for a great display!

Crease Pattern:

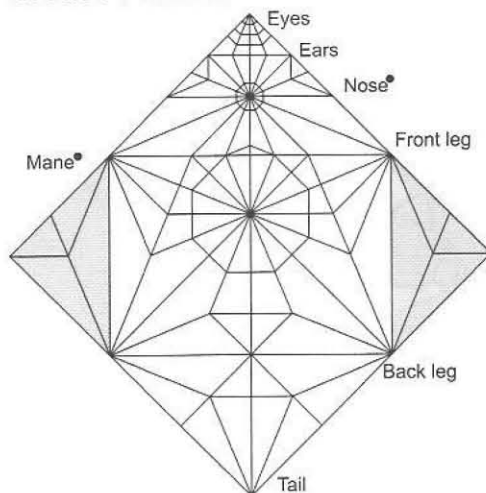

Paper:

Single Uncut Square
 Size: 40 cm
 Color: Any Duo-colour
 Type: Kami

OK
Good
Best

 Foil

Good
Best

 Wet-Fold

Best

Ratio: 0.30 Height

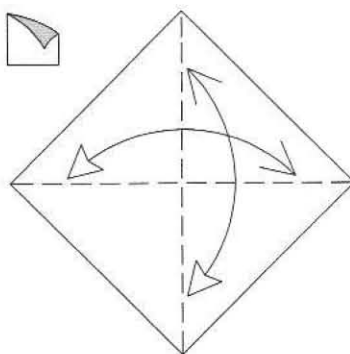
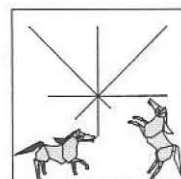

1. Pre-crease.

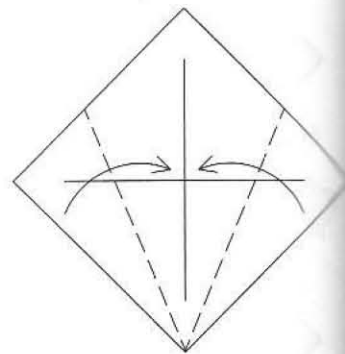

2. Valley Folds.

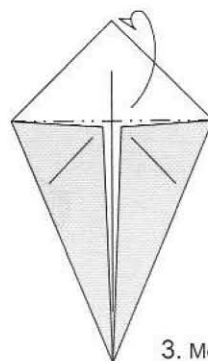

3. Mountain Fold.

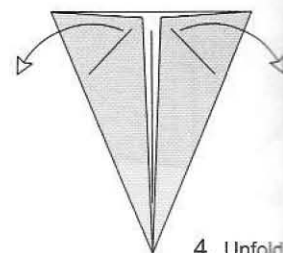

4. Unfold.

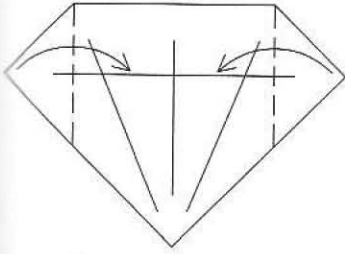

5. Valley Folds.

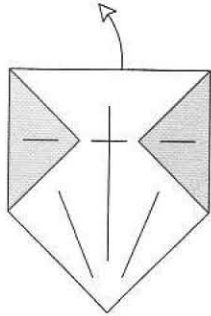

6. Unfold the raw corner.

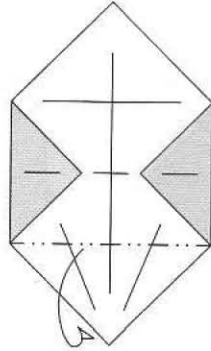

7. Mountain Fold.

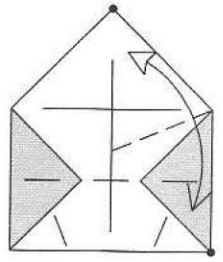

8. Valley Fold marker to marker and Unfold.

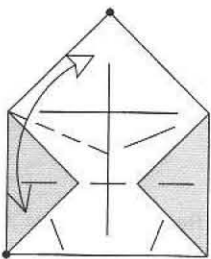

9. Repeat step 8 on the left.

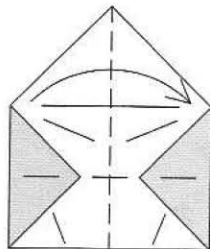

10. Valley Fold in half.

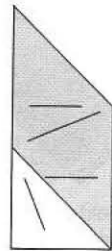

11. Rotate.
Enlarge.

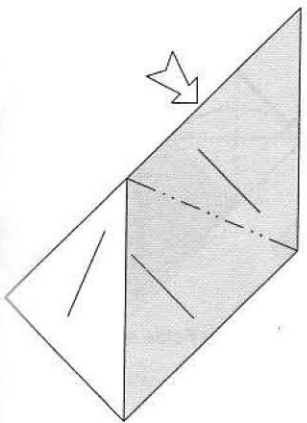
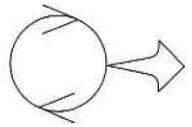

12. Inside Reverse Fold.
Enlarge.

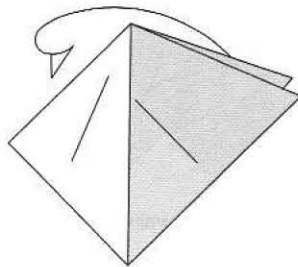

13. Swing the flap at the back
to the left.

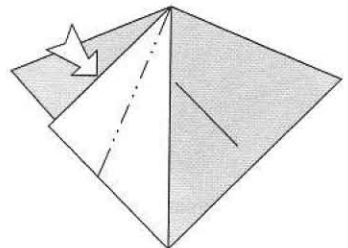

14. Squash Fold.

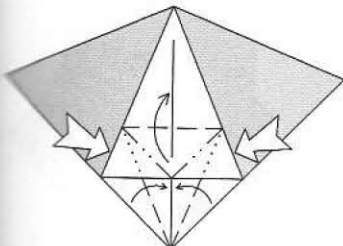

15. Petal Fold.

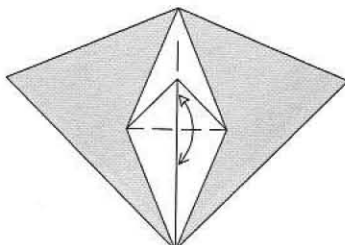

16. Valley Fold and Unfold.

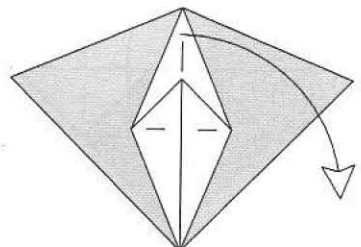

17. Unfold the raw corner
completely.

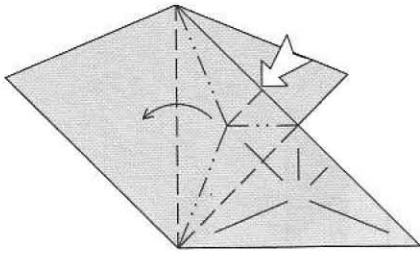

18. Reshape the Petal Fold made in step 15.

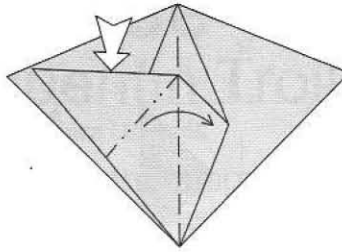

19. Squash Fold.

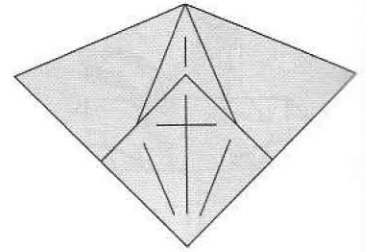

20. Turn over.

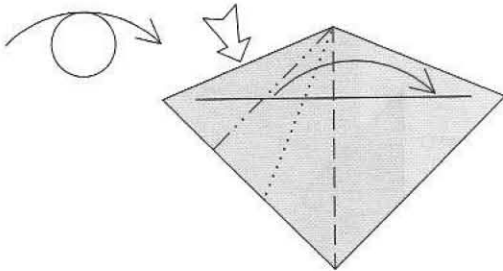

21. Squash Fold asymmetrically to the right.

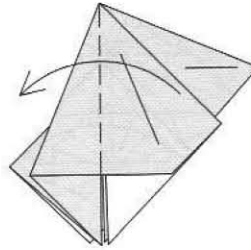

22. Valley Fold.

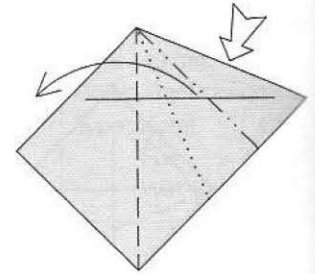

23. Repeat steps 21 to 22 on the right.

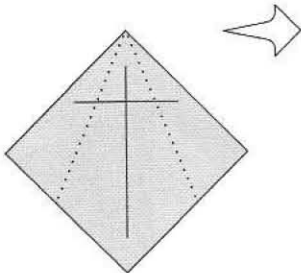

24. Enlarge.

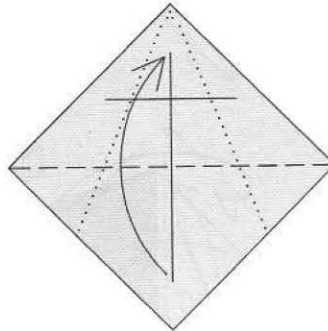

25. Valley Fold.

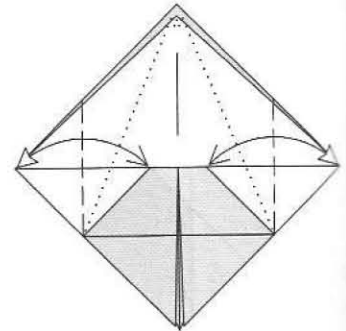

26. Valley Folds and Unfold.

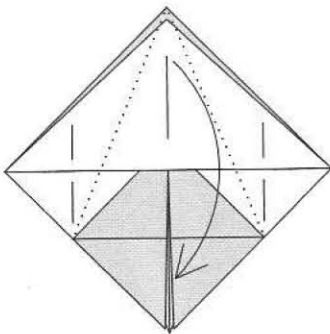

27. Valley Fold the raw corner down.

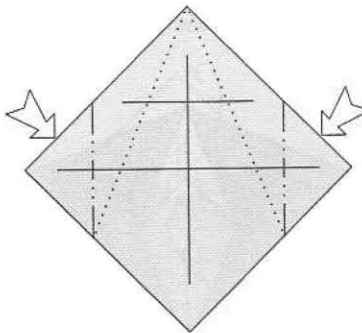

28. Inside Reverse Folds.

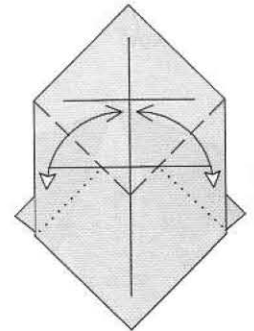

29. Valley Folds and Unfold the top layer.

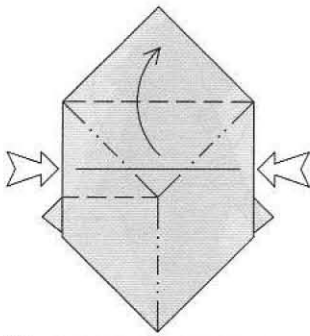

30. Squash Fold the flap up.

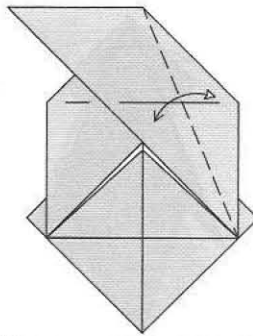

31. Valley Fold and Unfold.

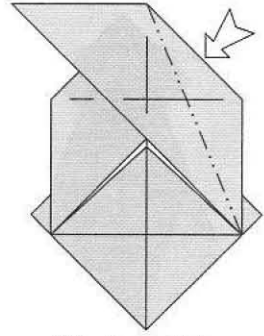

32. Open Sink.

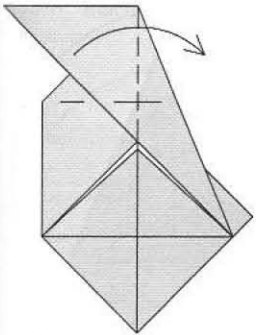

33. Valley Fold.

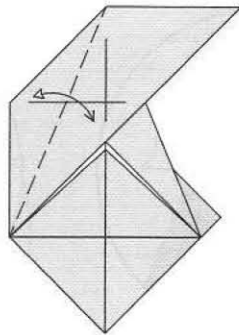

34. Repeat steps 31 to 32 on the left.

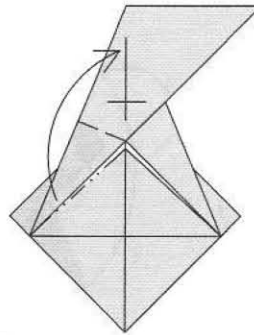

35. Valley Fold the point up. The model will not lie flat.

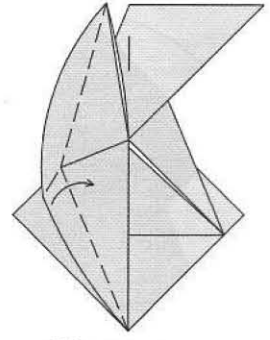

36. Flatten.

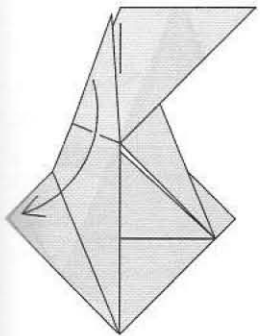

37. Valley Fold the point down.

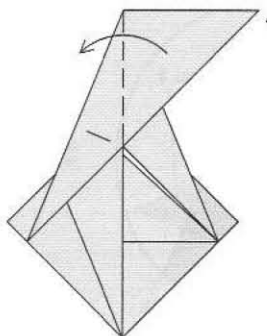

38. Valley Fold to the left.

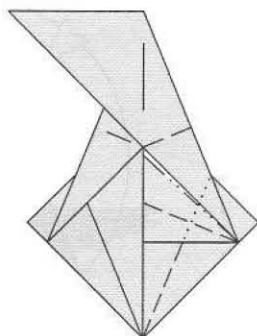

39. Repeat steps 35 to 37 on the right.

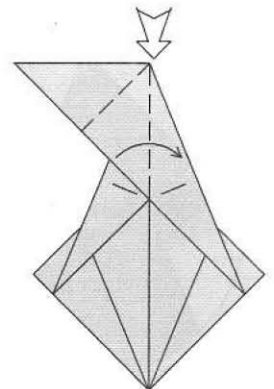

40. Squash Fold.

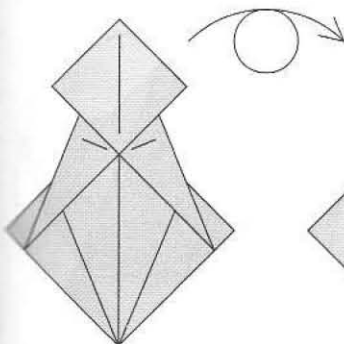

41. Turn over.

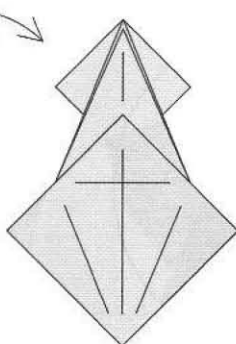

42. Like this.

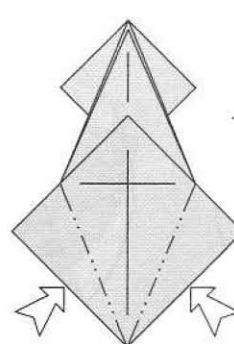

43. Inside Reverse Folds on existing creases.

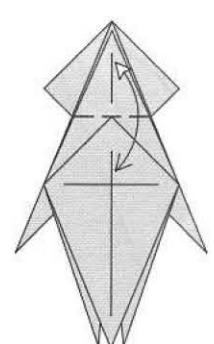

44. Valley Fold and Unfold the thick point.

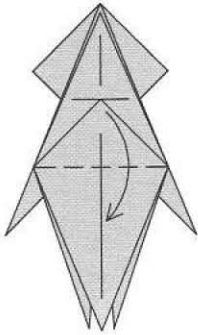

45. Valley Fold the point down.

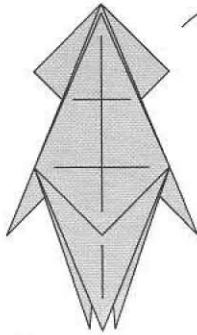

46. Turn over.

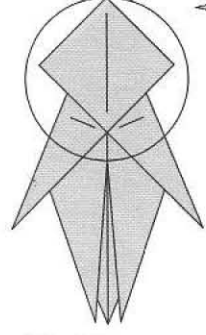

47. Enlarge.

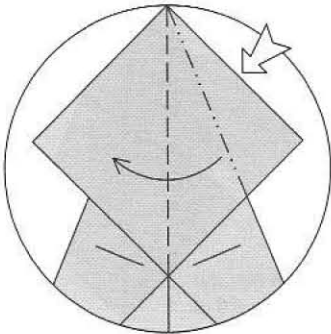

48. Squash Fold.

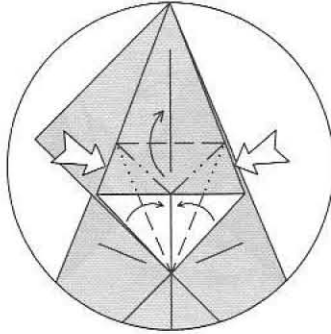

49. Petal Fold.

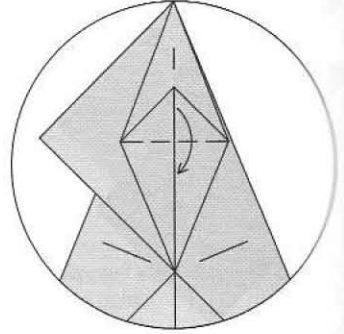

50. Valley Fold down.

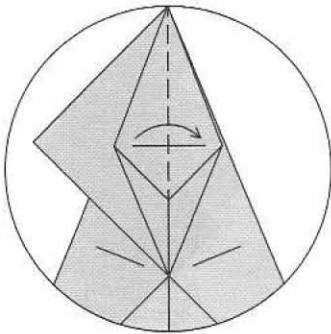

51. Valley Fold.

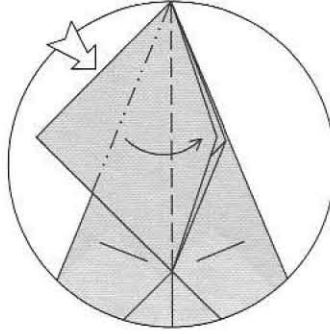

52. Repeat steps 48 to 51 on the left.

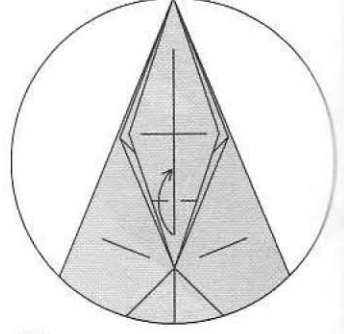

53. Valley Fold to the center.

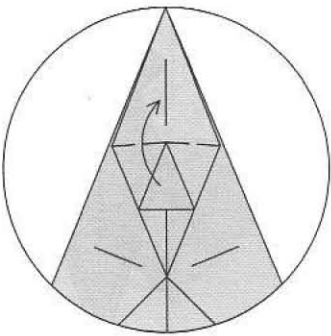

54. Valley Fold up.

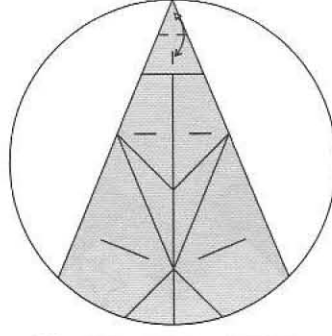

55. Valley Fold and Unfold the top point only.

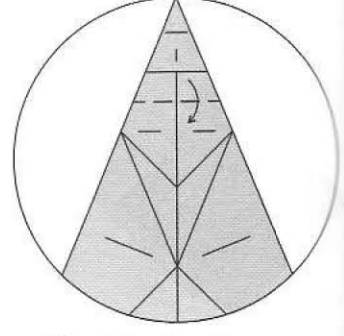

56. Valley Fold down.

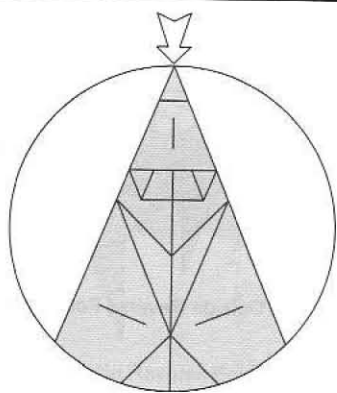

57. Open Sink on creases made in step 55.

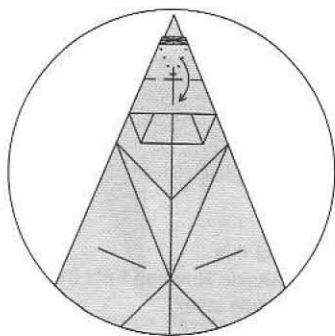

58. Flatten to spread the layers.

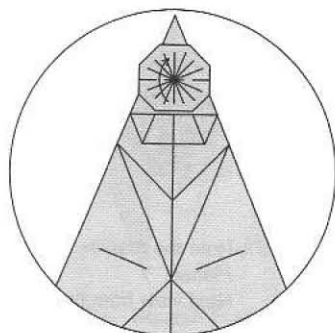

59. Valley Fold.

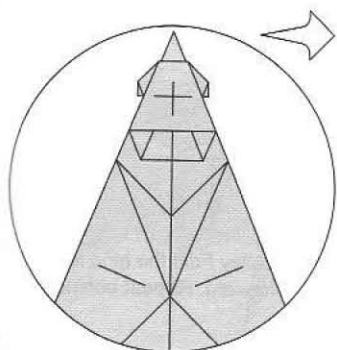

60. Scale change.

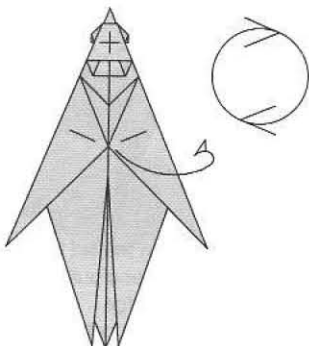

61. Mountain Fold the model in half. Rotate.

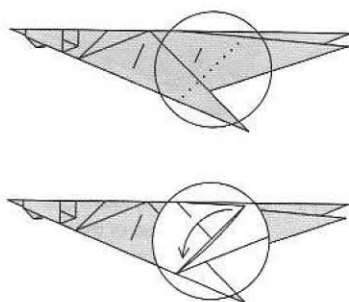

62. X-Ray view. Valley Fold to lock the model.

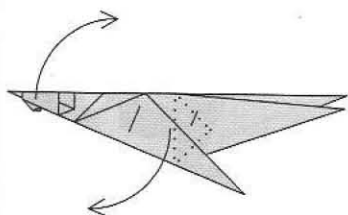

63. Slide the head and forelegs up and forwards together. See step 62 for orientation of the layers.

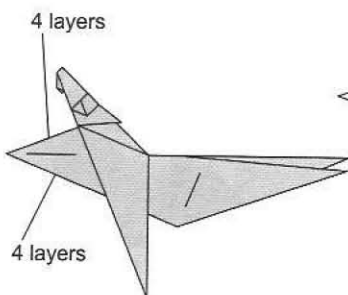

64. Like this.

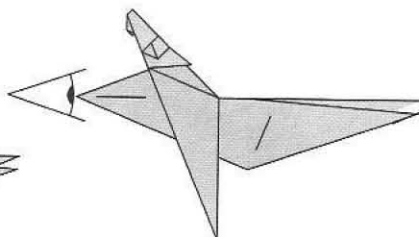

65. Spread the layers at the front of the model. This is an Open Sink. Change view.

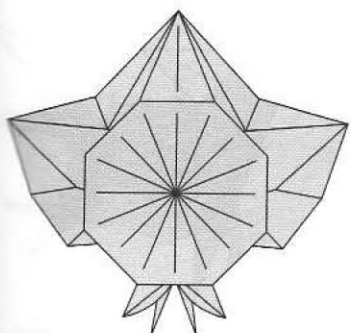

66. Like this. Push the layer into the model.

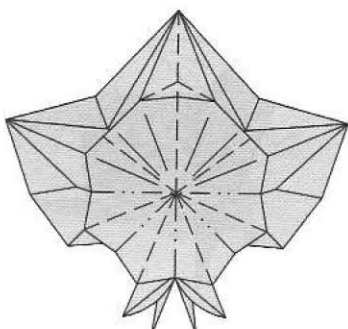

67. Pinch the layers of the legs together.

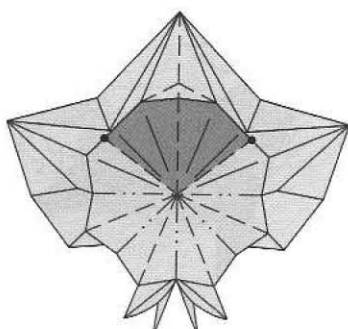

68. The darker layer should form the mane. See step 68.

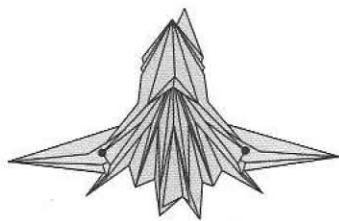

69. Note the marker.
Flatten.
Next view from the side.

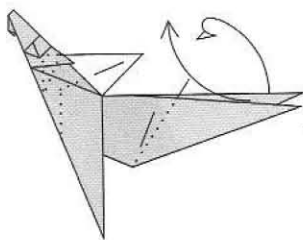

70. Like this.
Outside Reverse Fold the
middle layer.

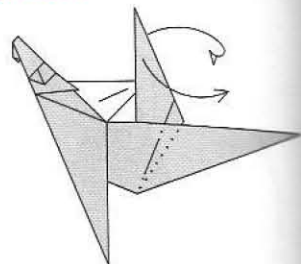

71. Outside Reverse Fold again.

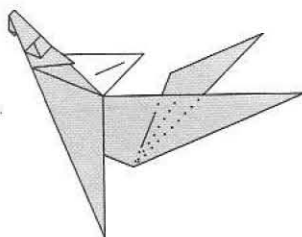

72. steps 73 to 76 show the
colour-change of the tail
and are optional.

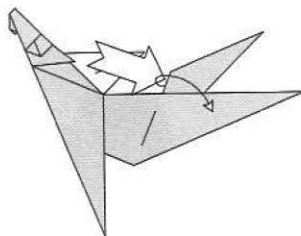

73. Open the tail from the
front and pull out the
raw edge.
Repeat behind.

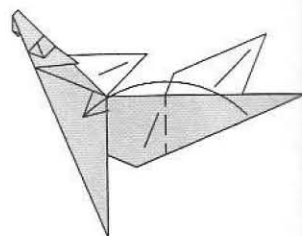

74. Valley Fold the hind leg
forward. Repeat behind.

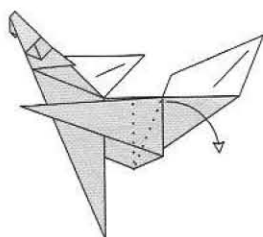

75. Release the raw edge
even further. Repeat behind.

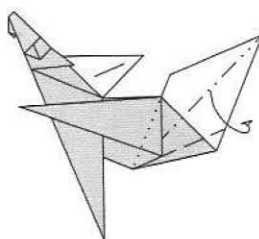

76. Mountain Fold the raw
edge inside. Repeat behind.

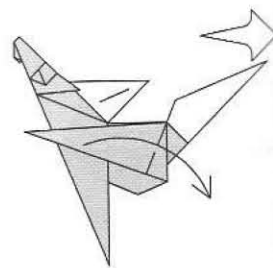

77. Valley Fold the hind leg.
Repeat on the other hind leg.
Enlarge.

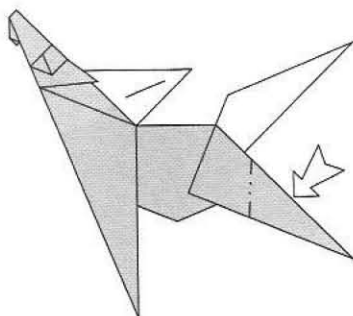

78. Inside Reverse Fold.
Repeat on the other hind leg.

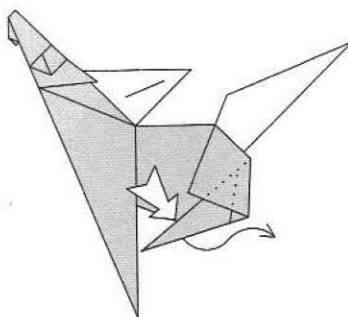

79. Inside Reverse Fold.
Repeat on the other hind leg.

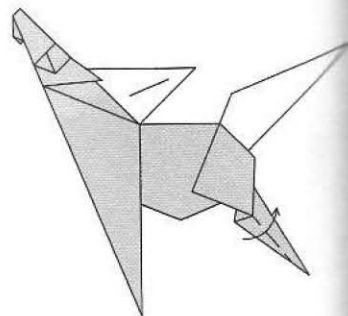

80. Swivel Fold.
Repeat behind.
Repeat on the other hind leg.

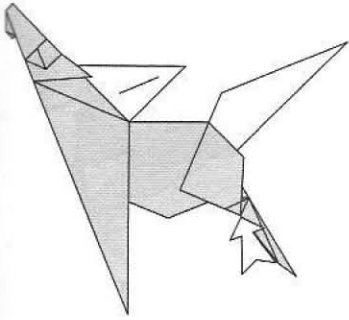

81. Inside Reverse Fold the point. Repeat behind. Repeat on the other hind leg.

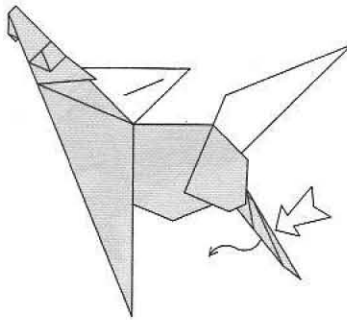

82. Inside Reverse Fold. Repeat on the other hind leg.

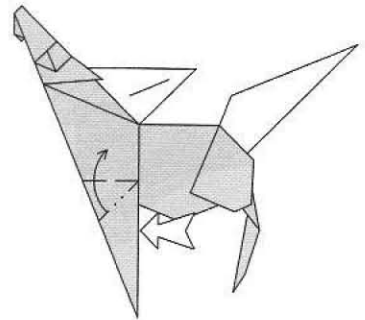

83. Squash Fold. Repeat on the other front leg.

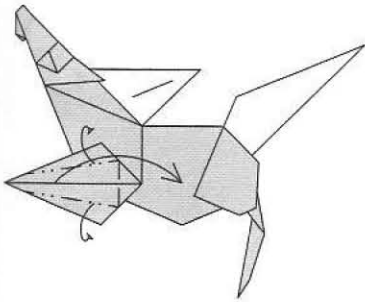

84. Petal Fold. Repeat on the other front leg.

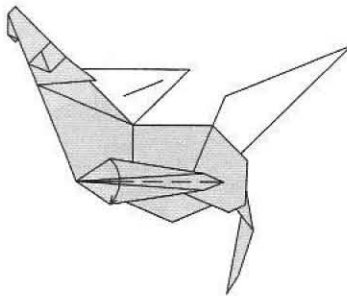

85. Valley Fold. Repeat on the other front leg.

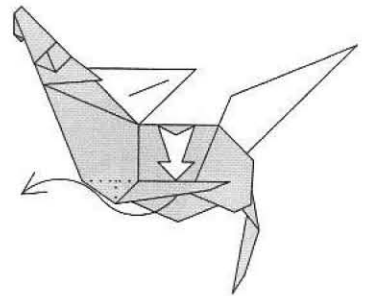

86. Inside Reverse Fold. Repeat on the other front leg.

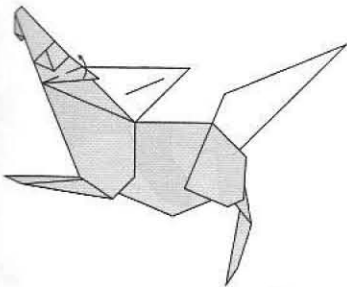

87. Valley Fold the ears.

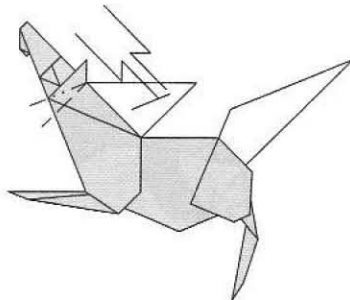

88. Outside Crimp Fold the neck.

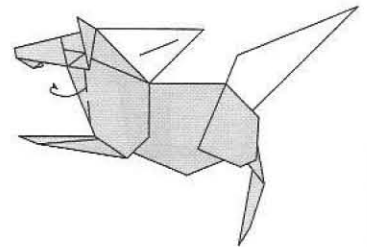

89. Mountain Fold. Repeat behind.

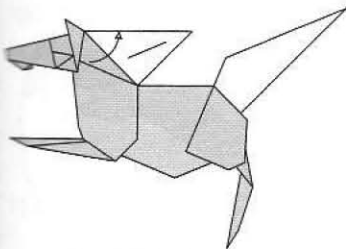

90. Unfold the layer. Repeat behind.

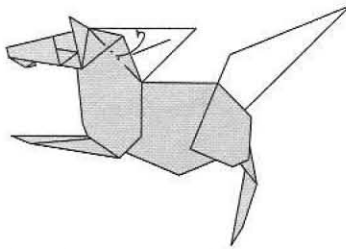

91. Mountain Fold behind the layer beneath it. Repeat behind.

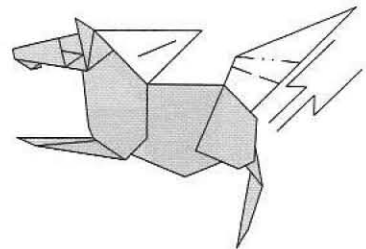

92. Outside Crimp Fold.

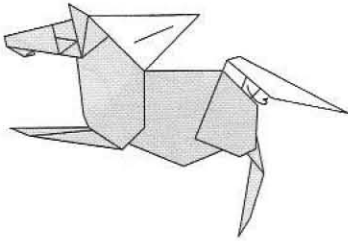

93. Mountain Fold into the layers on the inside to lock them. Repeat behind.

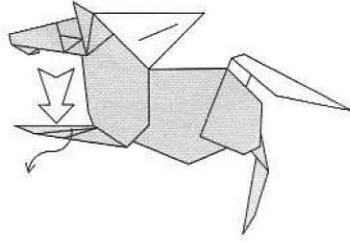

94. Inside Reverse Fold the front legs. Repeat behind.

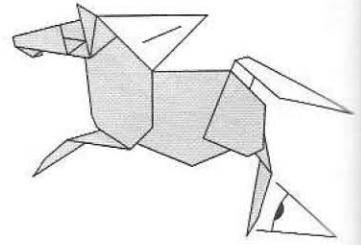

95. Open the layers of the leg and look at them from behind.

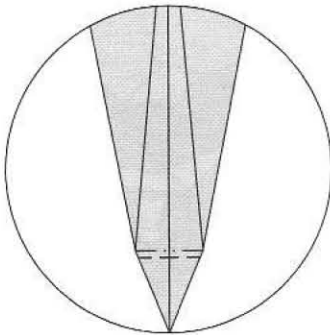

96. Crimp Fold.

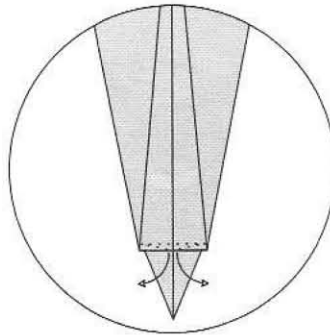

97. Unfold the raw edges.

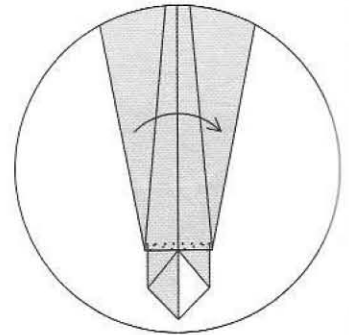

98. Valley Fold.

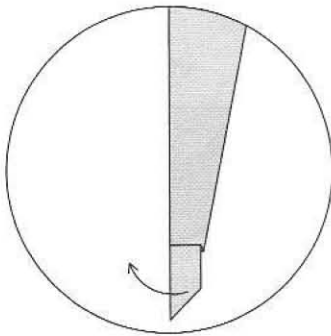

99. Slide the hoof forward.

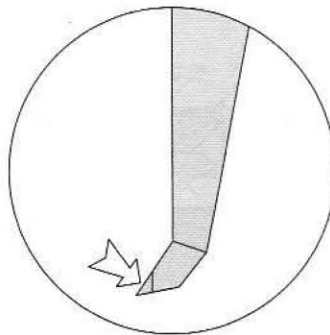

100. Inside Reverse Fold.

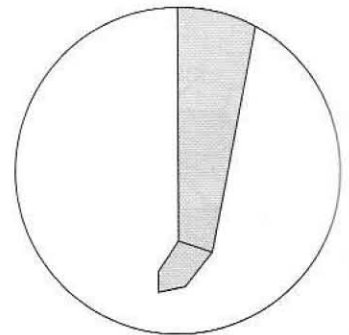

101. Repeat steps 96 to 100 on the other hind leg. Scale change.

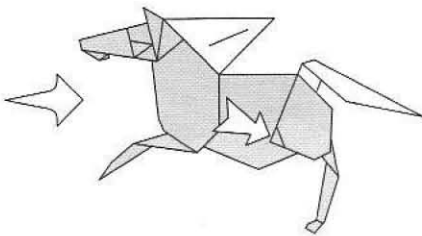

102. Inside Reverse Fold. Repeat behind.

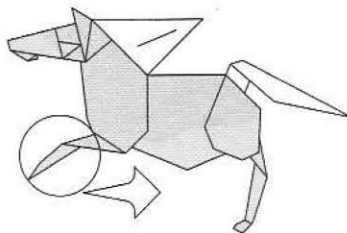

103. Enlarge.

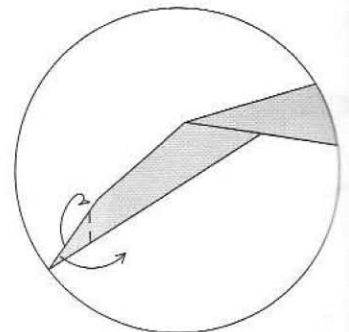

104. Outside Reverse Fold.

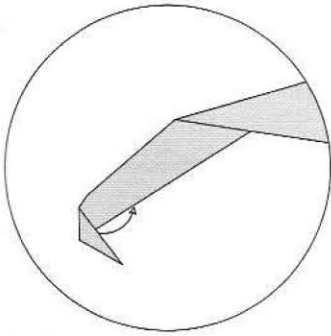

105. Pull out a layer from inside. Repeat behind. Repeat on the other leg.

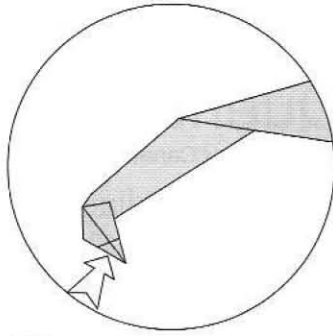

106. Inside Reverse Fold. Repeat on the other leg.

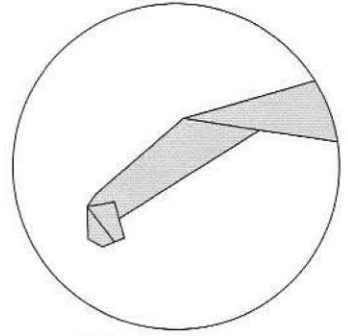

107. Scale change.

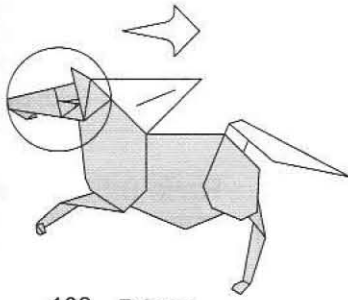

108. Enlarge.

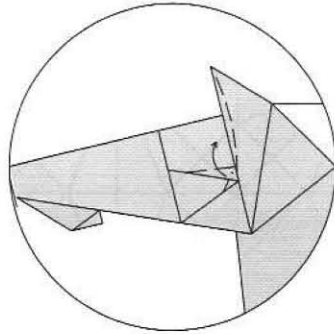

109. Shape the eyes and ears.

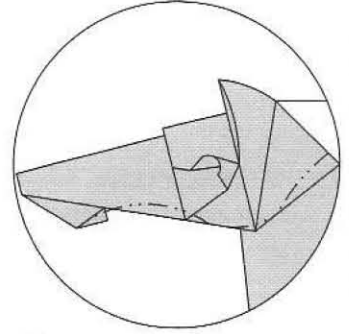

110. Round the jaw muscles.

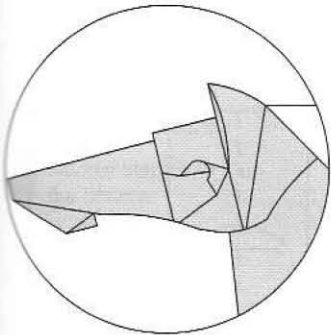

111. Pull down the lower jaw.

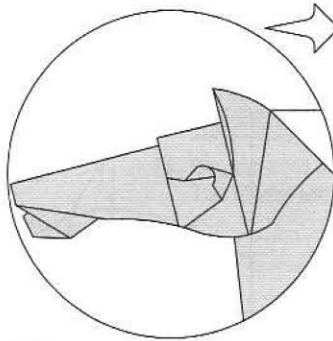

112. Like this. Scale change.

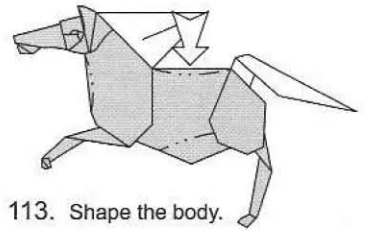

113. Shape the body.

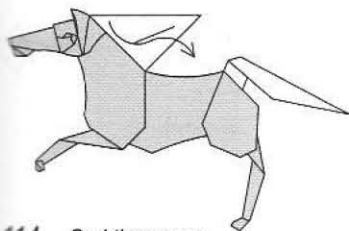

114. Curl the mane. Turn the head slightly to the same side as the mane. This will keep the mane folds in shape.

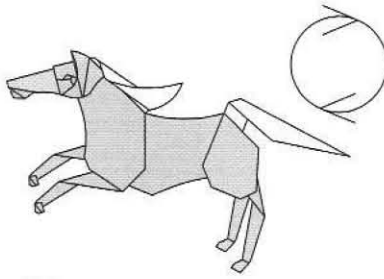

115. Slide the hind legs back and stand the horse on its hind legs and tail.

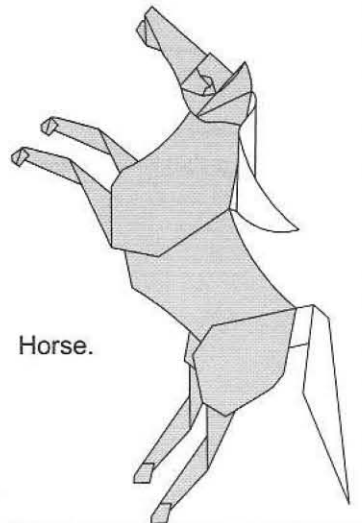

Horse.

Orang Utan Quentin Trollip

South Africa / Canada

Design and diagram info:

Date: 07 July 2007

Difficulty: Complex

Time to fold: 2 Hours

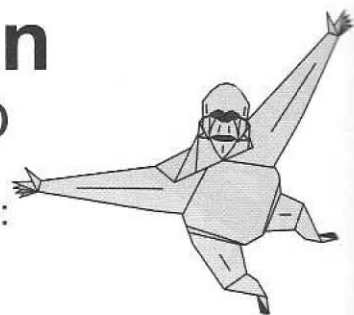

The Orang Utan, translated as “Old Man of the Woods”, was designed as a challenge. I used a similar base as the one for my Common Raven, but with symmetrical proportions for the arms and legs, as well as extra layers for the facial features, which is what makes this such an attractive model.

The distribution of layers in steps 44 to 65 were added later to give a closed front and back.

This model will take some practice to get the facial features right. 3 dimensional shaping is necessary, and the folders can use their own initiative for this. Wet-folding or dry wet-folding will help to keep the folds in place. Thicker paper up to 120gsm will work, but thinner than that is advised.

Crease Pattern:

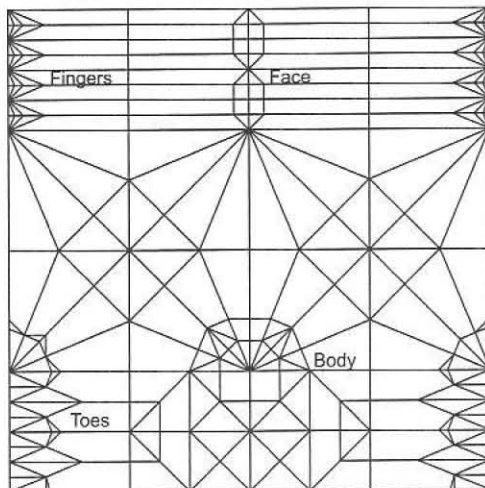

Paper:

Single Uncut Square

Size: 50 cm

Color: Orange-Orange

Type: Kami

Foil

Wet-Fold

NO

OK

Best

Ratio: 0.53 Width

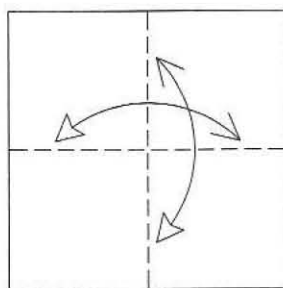
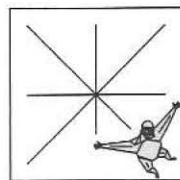

1. Pre-crease.

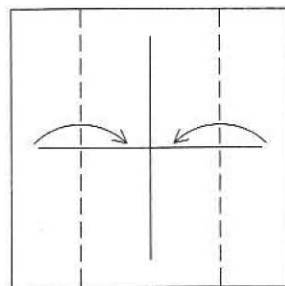

2. Valley Fold to the center.

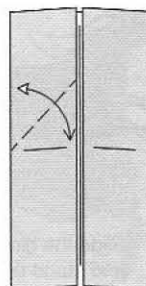

3. Valley Fold and Unfold through both layers.

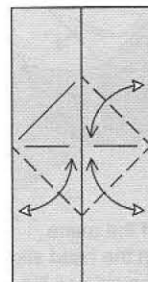

4. Repeat step 3 on the other three sides. Enlarge.

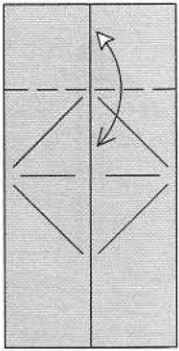

5. Valley Fold and Unfold.

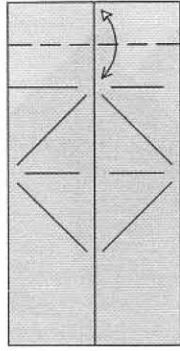

6. Valley Fold and Unfold.

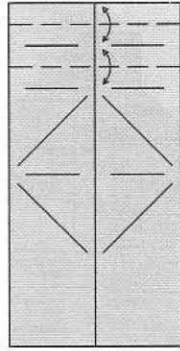

7. Valley Fold to divide into 1/4.

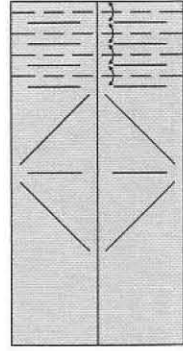

8. Valley Fold to divide into 1/8.

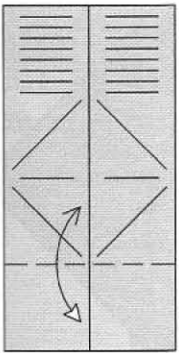

9. Repeat steps 5 to 7 on the bottom.

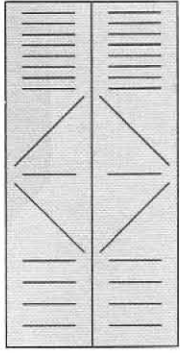

10. Like this.

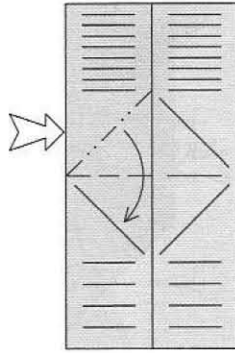

11. Squash Fold down. The model will not lie flat.

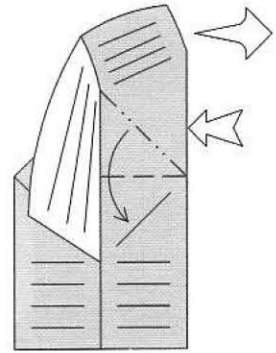

12. Squash Fold the right raw edge down and flatten. Enlarge.

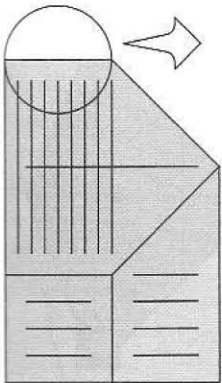

13. Enlarge.

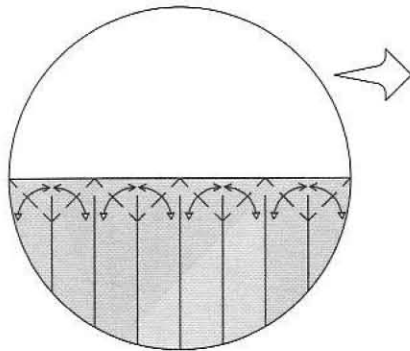

14. Pre-creases. Scale change.

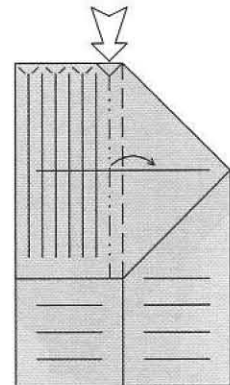

15. Spread Squash.

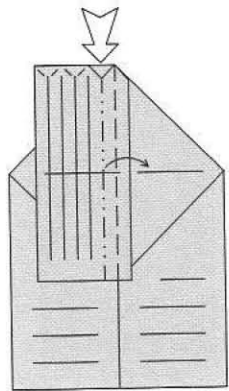

16. Spread Squash the next creases.

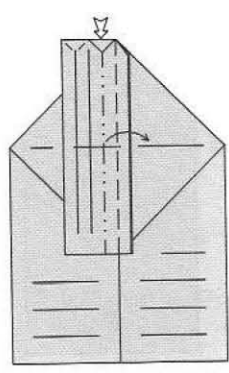

17. Spread Squash the next creases.

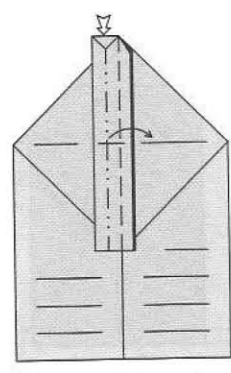

18. Spread Squash the next creases.

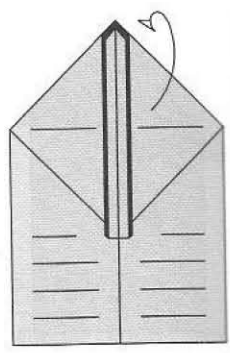

19. Pivot to the back.

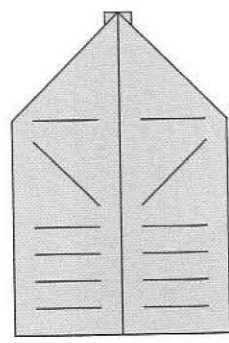

20. Rotate.

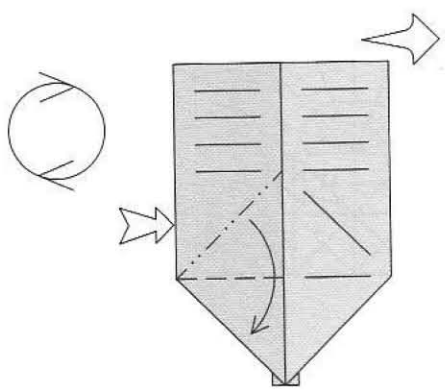

21. Repeat steps 11 to 12 on this side. Enlarge.

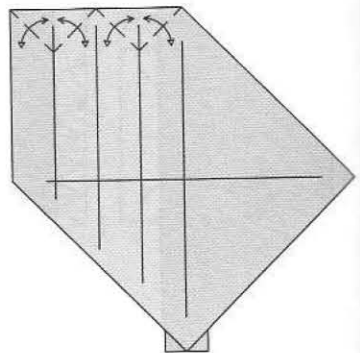

22. Valley Folds and Unfold.

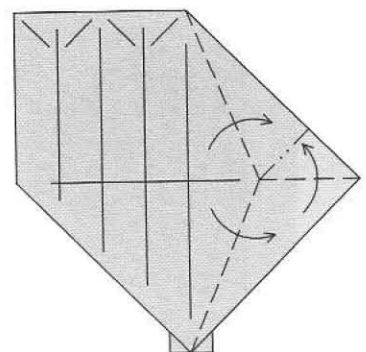

23. Rabbit Ear the point.

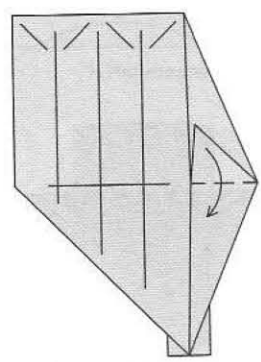

24. Valley Fold down.

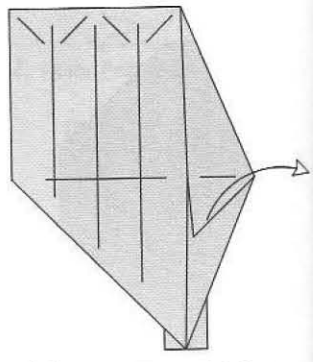

25. Unfold the Rabbit Ear.

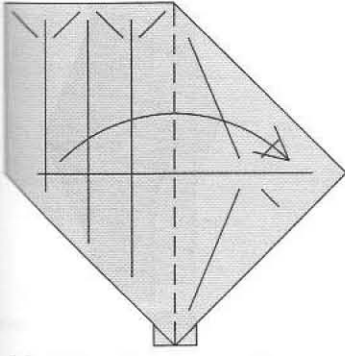

26. Valley Fold the raw edges to the right.

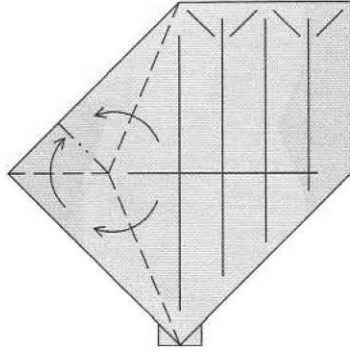

27. Repeat steps 23 to 25 on the right.

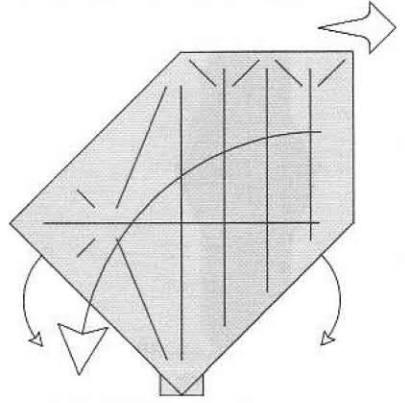

28. Unfold the raw edge all the way. Scale change.

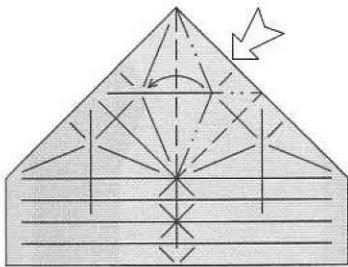

29. Squash Fold and then Petal Fold on existing creases. The model will not lie flat.

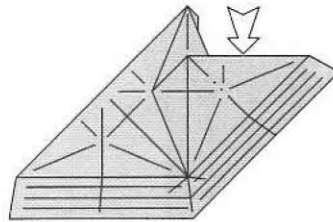

30. Inside Reverse Fold. The model will still not lie flat.

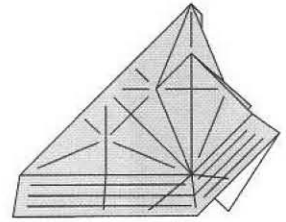

31. Like this.

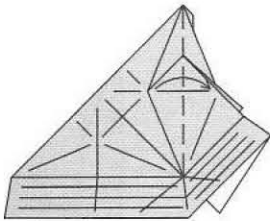

32. Valley Fold one layer to the right.

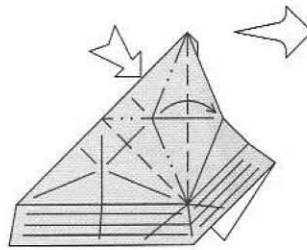

33. Repeat steps 29 to 32 on the left. Enlarge.

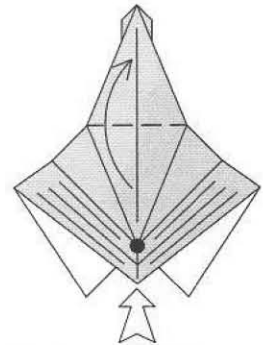

34. Closed Unsink the marked point upwards.

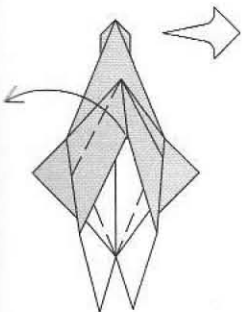

35. Flatten to the left. Enlarge.

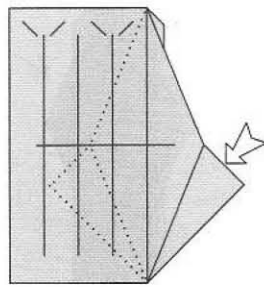

36. Inside Reverse Folds on existing creases. Repeat on the left.

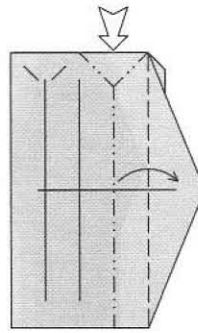

37. Spread Squash.

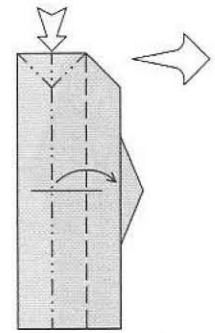

38. Spread Squash again. Enlarge

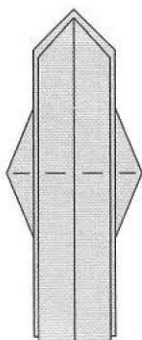

39. Like this.

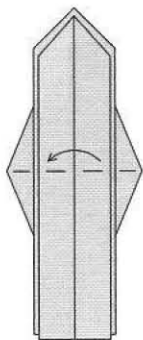

40. Valley Fold three layers to the left.

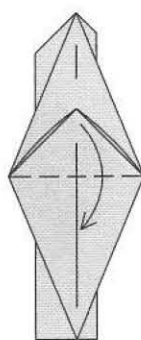

41. Valley Fold down.

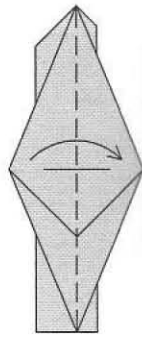

42. Valley Fold the layers to the right again.

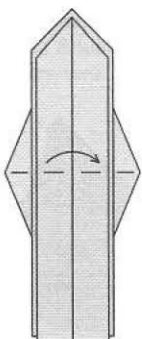

43. Repeat steps 40 to 42 on the left.

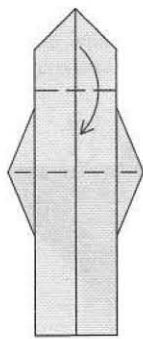

44. Valley fold the whole flap down.

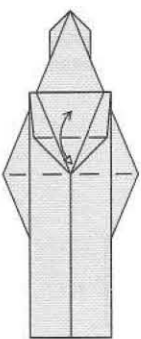

45. Valley Fold and Unfold the top point only.

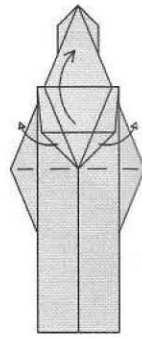

46. Valley Fold the top point while opening the layers. Flatten.

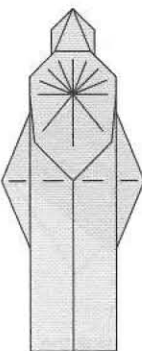

47. Like this.

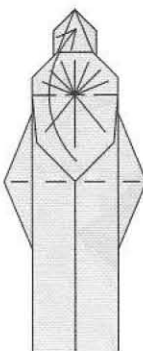

48. Valley Fold two points up.

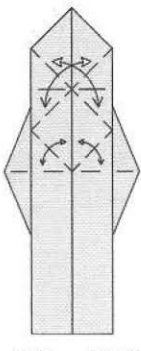

49. Valley Fold and Unfold through the top two layers only.

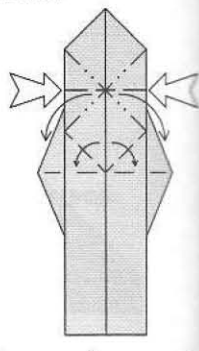

50. Place your fingers under two layers and Elias-Stretch down.

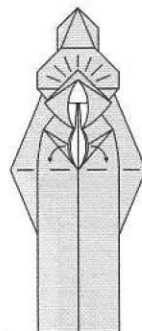

51. In progress...

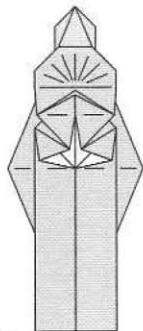

52. Flatten.

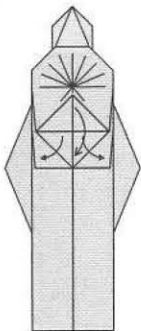

53. Valley Fold one point down while Unfolding the raw edges.

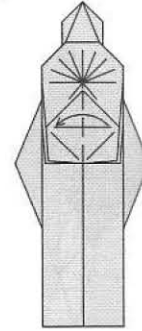

54. Valley Fold one layer to the left. You may have to unstick a layer at the back.

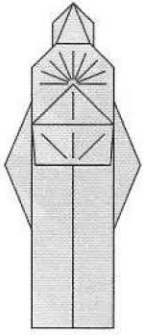

55. Like this.

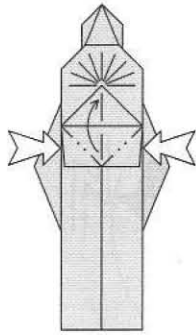

56. Petal Fold the raw edge up.

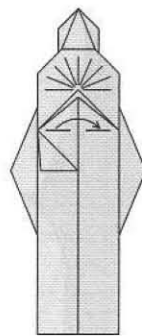

57. Valley Fold one layer to the right.

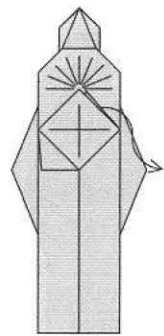

58. Reverse Fold the point down.

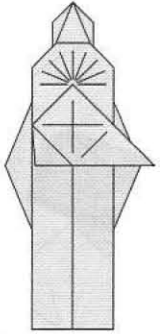

59. Like this.
Repeat steps 54 to 58 on the left.

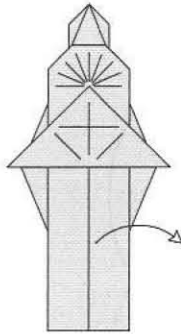

60. Unfold the raw corner totally. Some of the layers will have to be untrapped to do this.

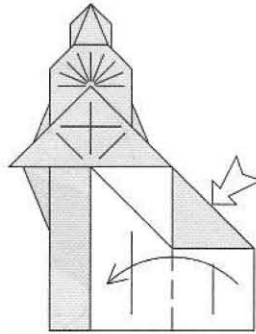

61. Inside Reverse Fold.

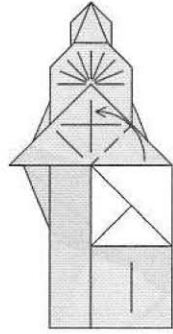

62. Valley Fold the point up and flatten the raw edge.

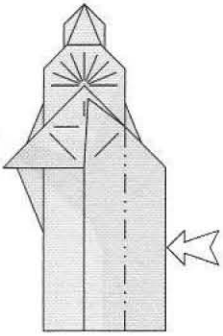

63. Open Sink.

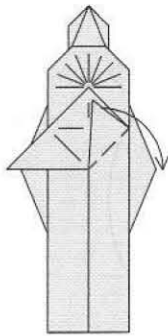

64. Valley Fold the point down.

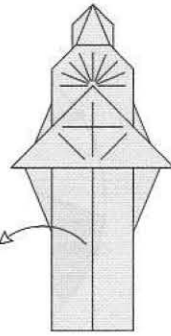

65. Repeat steps 60 to 64 on the left.

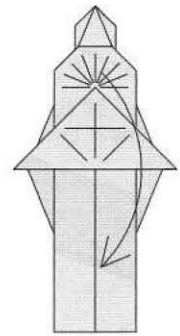

66. Valley Fold the whole flap down.

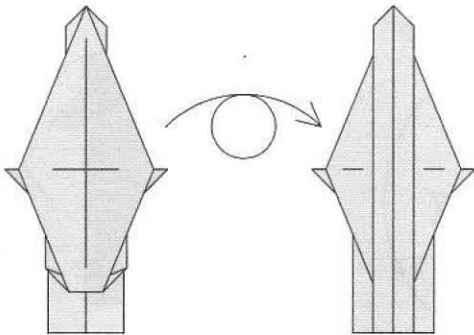

67. Turn around.

68. Like this.

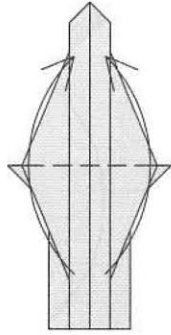

69. Valley Fold two flaps up.

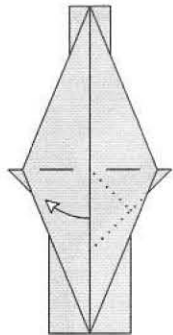

70. Pull the triangle under the front flap to the front and left.

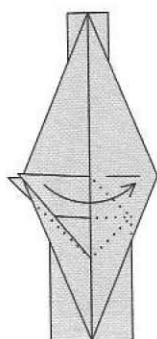

71. Valley Fold the triangle to the right.

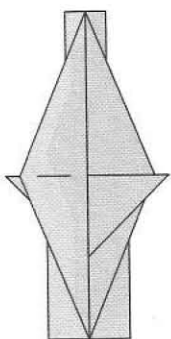

72. Repeat steps 70 to 71 on the left.

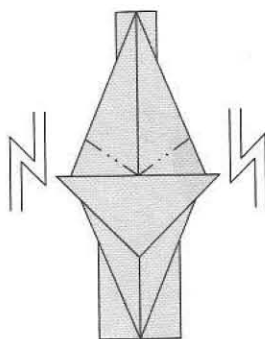

73. Pleat Fold both flaps.

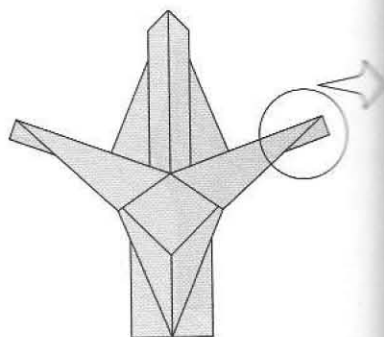

74. Enlarge.

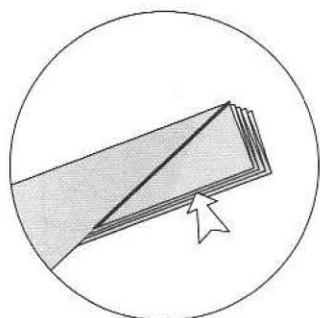

75. Inside Reverse Fold the top layer on the thick line.

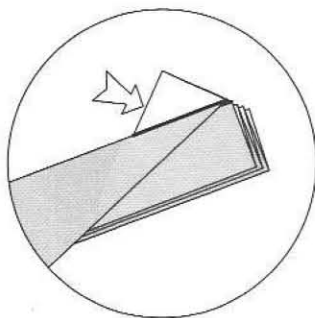

76. Inside Reverse Fold again on the thick line.

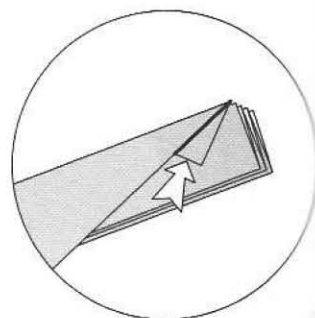

77. Inside Reverse Fold again on the thick line.

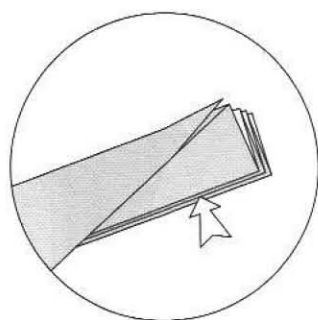

78. Repeat steps 75 to 77 on the three remaining points.

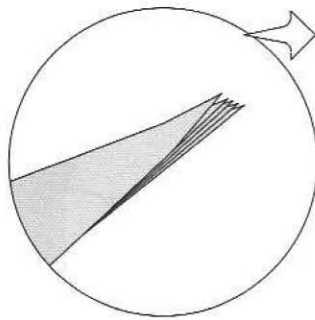

79. Like this. Scale change.

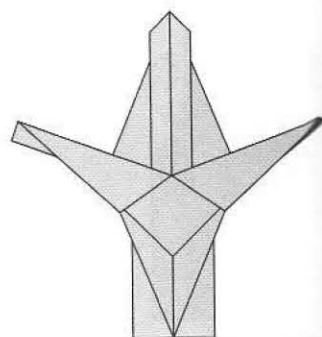

80. Repeat steps 75 to 78 on the left.

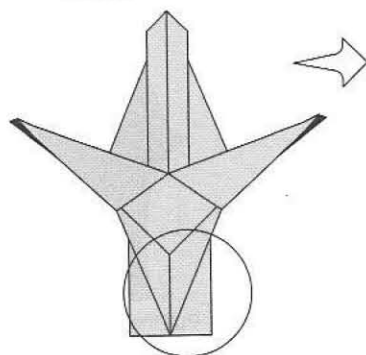

81. Enlarge.

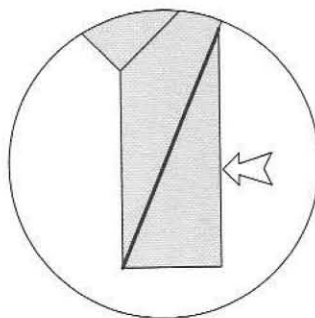

82. Only one leg shown. Inside Reverse Fold.

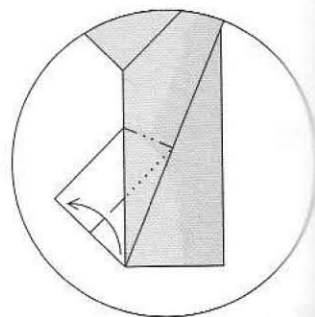

83. Inside Swivel Fold.

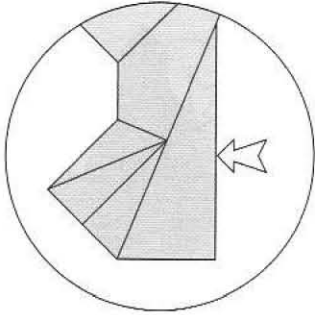

84. Repeat steps 82 to 83 on the back layer.

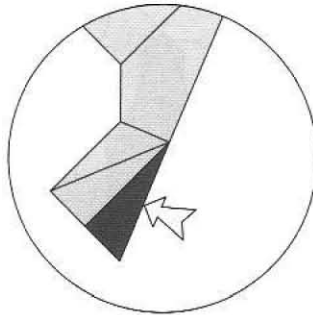

85. Open Sink the dark layer.

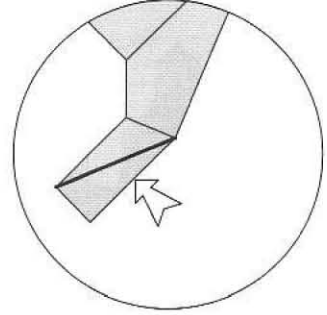

86. Inside Reverse Fold on the thick line.

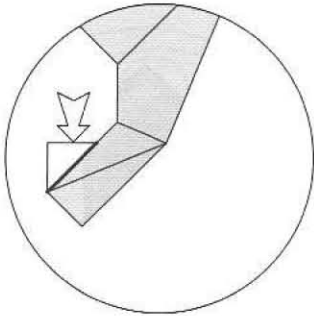

87. Inside Reverse Fold on the thick line.

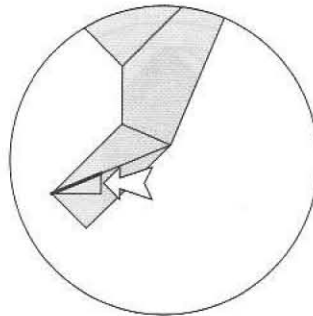

88. Inside Reverse Fold on the thick line.

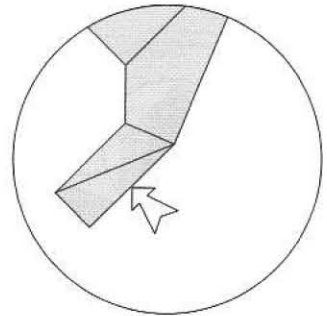

89. Repeat steps 86 to 88 on the remaining three points.

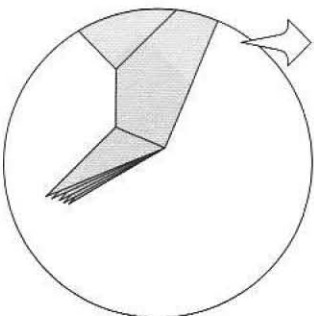

90. Scale change.

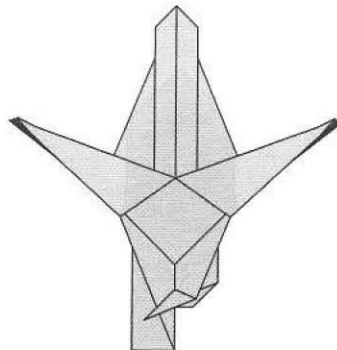

91. Repeat steps 82 to 89 on the left leg.

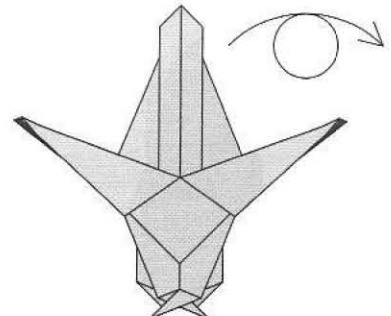

92. Turn around.

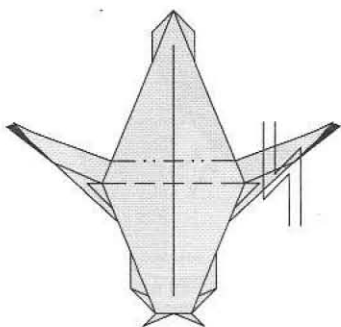

93. Pleat Fold and Unfold.

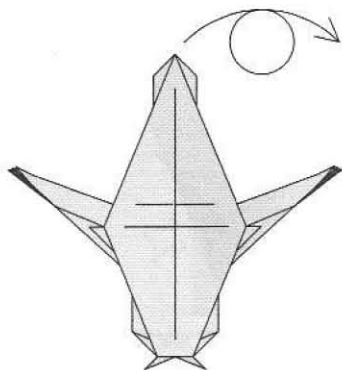

94. Turn around.

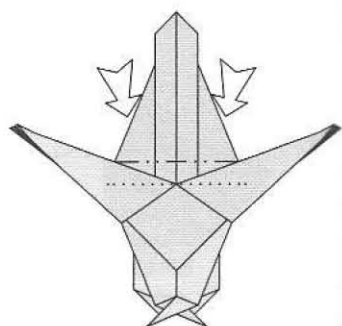

95. Open the layers and Closed Sink down and up.

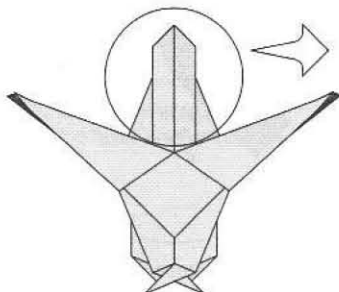

96. Enlarge.

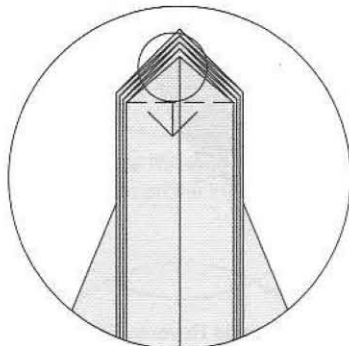

97. Elias-Stretch the first point down.

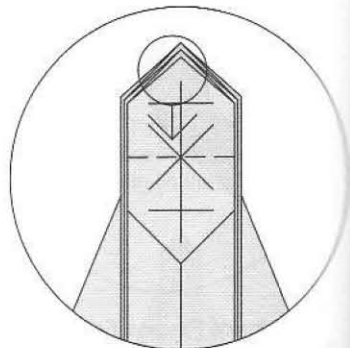

98. Elias-stretch the second point down also.

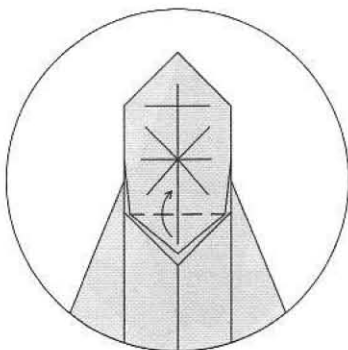

99. Valley Fold up.

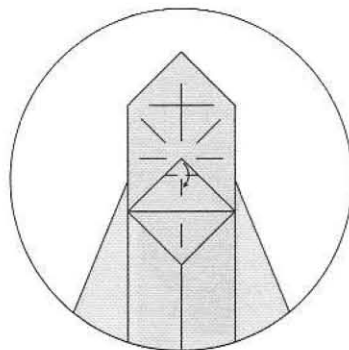

100. Valley Fold the tip down.

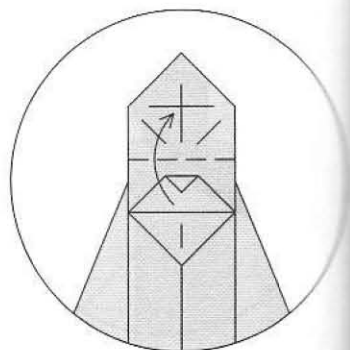

101. Valley Fold the flap up.

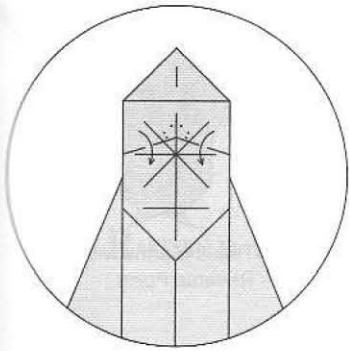

102. Valley Fold down.
Do not flatten.

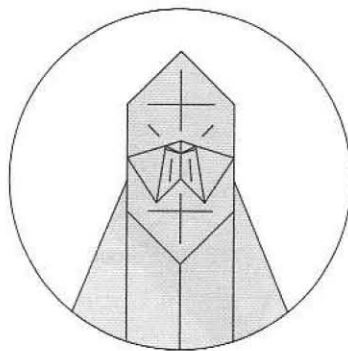

103. Round the upper lip.

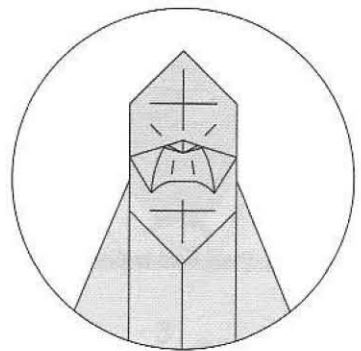

104. Open the nostrils.



105. Like this. Mountain Fold the
bottom point to the back.

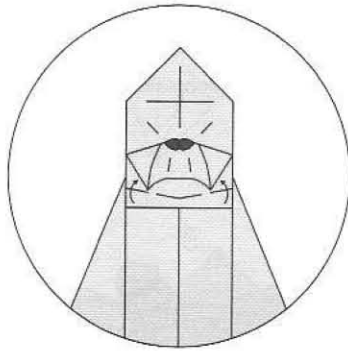

106. Valley Fold up and round
the lower lip.

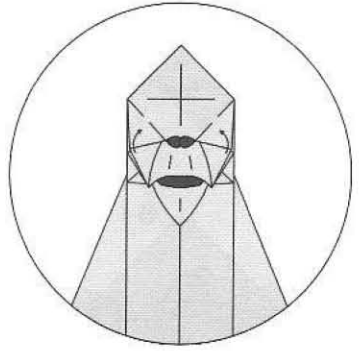

107. Pull out only the upper
layer where indicated.

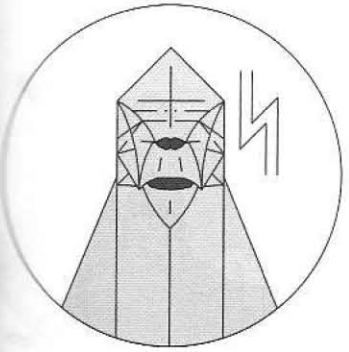

108. Pleat Fold to form the eyes.

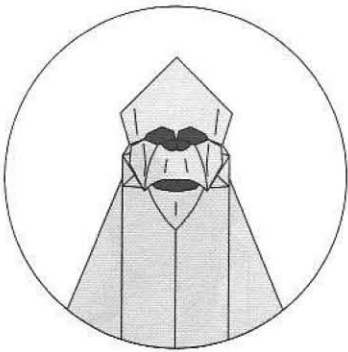

109. Shape the head 3D.

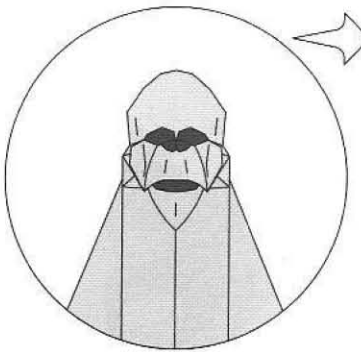

110. Scale change.

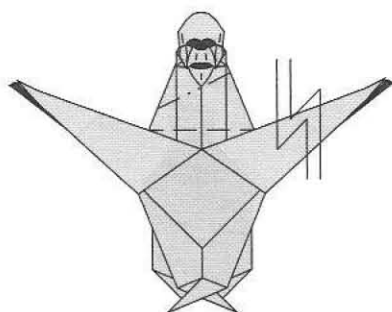

111. Pleat Fold to the front.

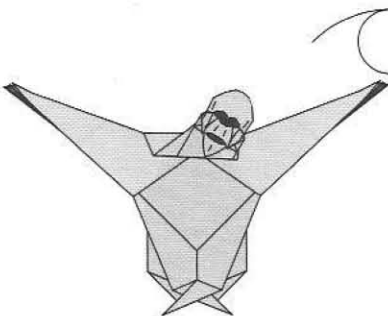

112. Turn around.

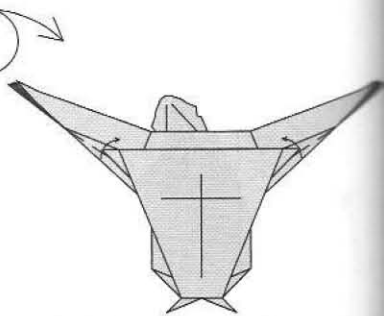

113. Thin the arms with Reverse Folds.

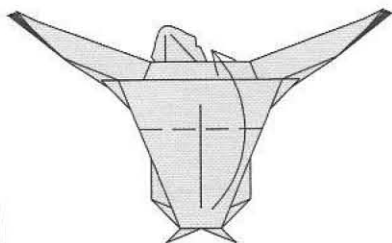

114. Valley Fold the flap up.

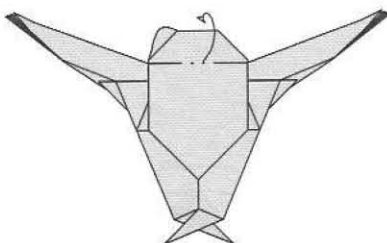

115. Mountain Fold.

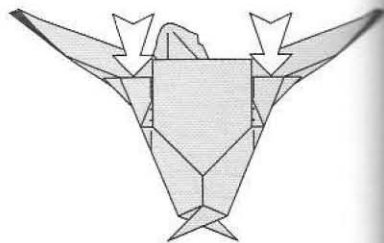

116. Inside Reverse Folds.

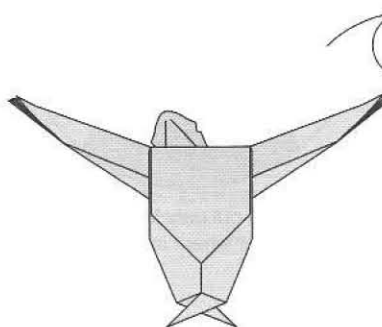

117. Turn around.

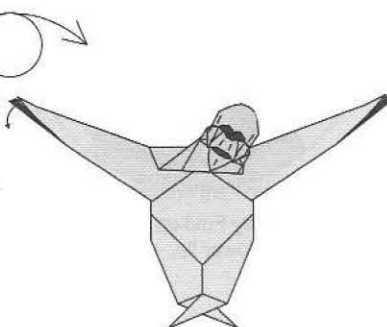

118. Spread the fingers.

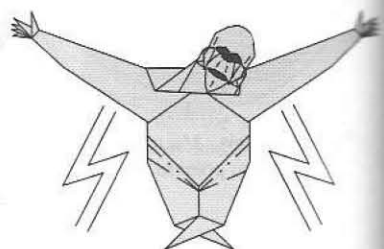

119. Pleat Fold the legs.

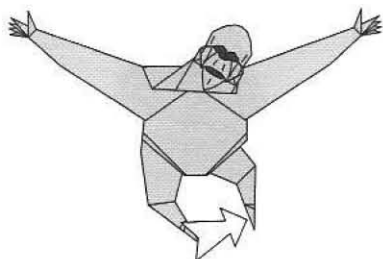

120. Inside Reverse Fold the toes.

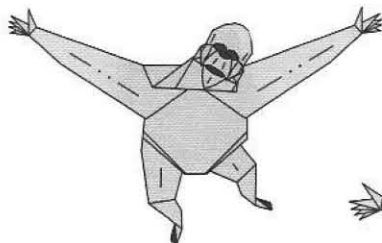

121. Shape the body.

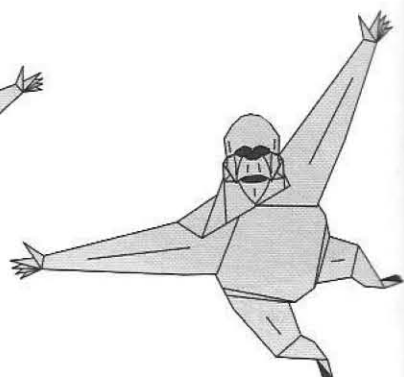

Orang Utan

DEVIL'S MASK

Román Díaz

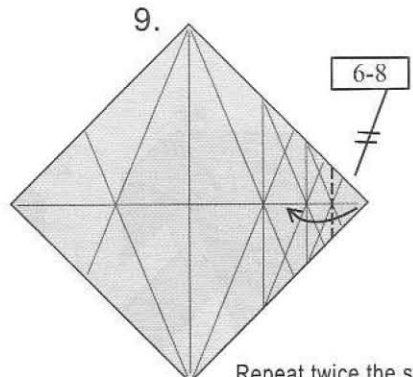
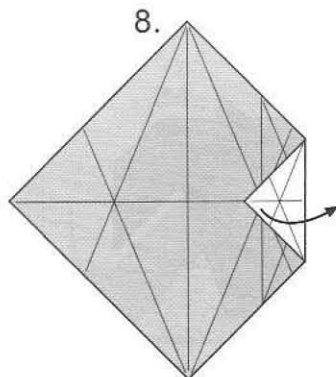
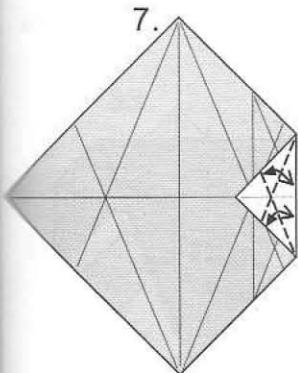
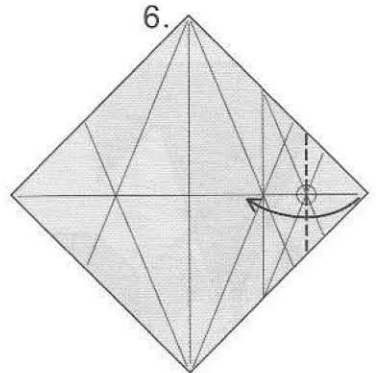
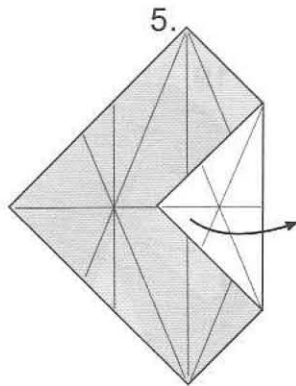
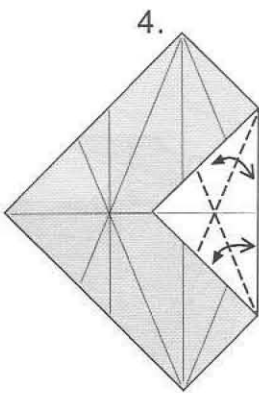
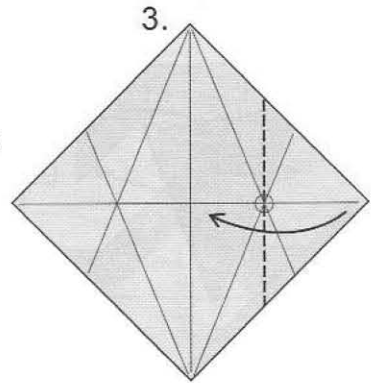
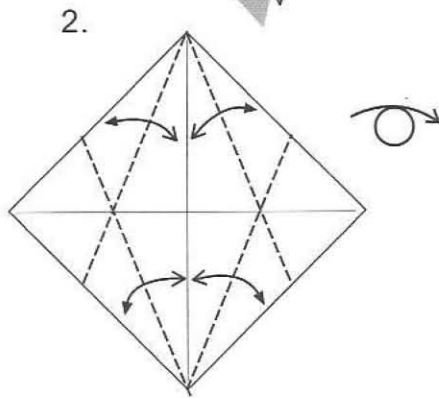
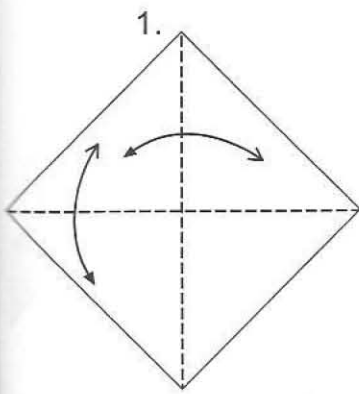
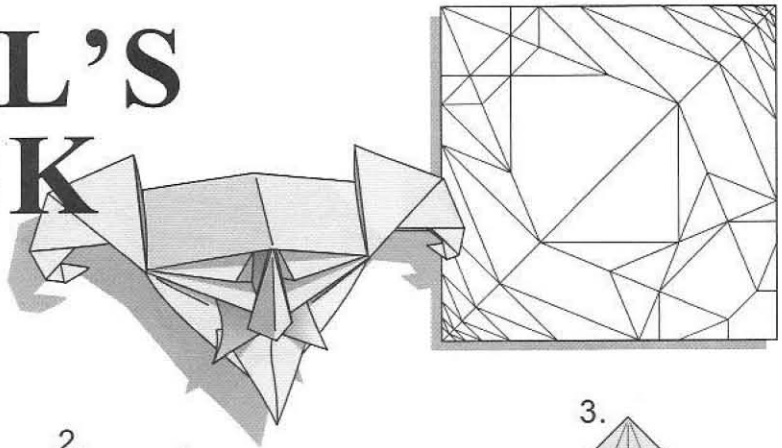

Repeat twice the same sequence of steps 6-8.

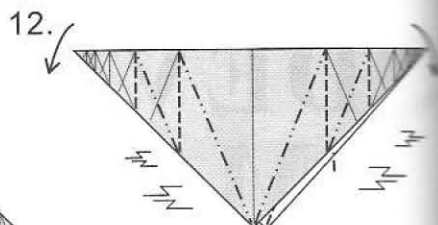
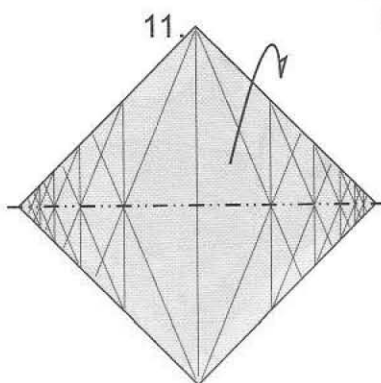
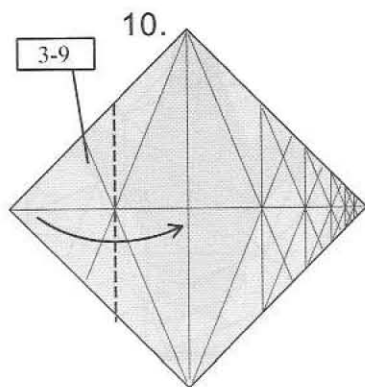

Pleat twice on each side.

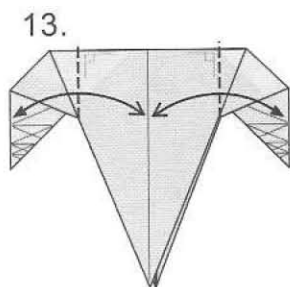

Crease firmly through all layers.

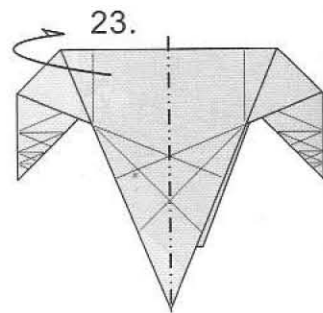
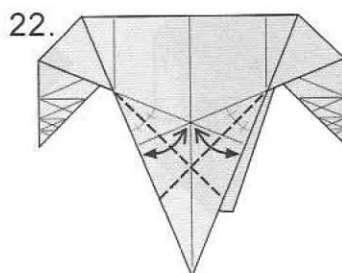
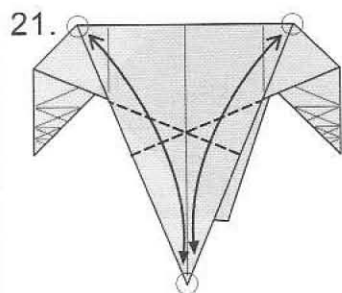
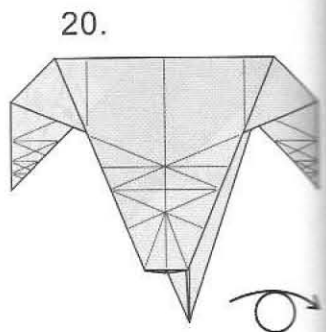
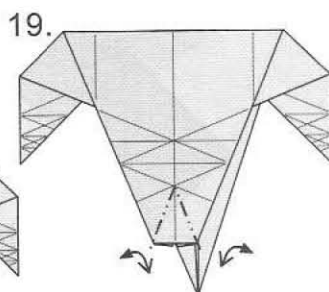
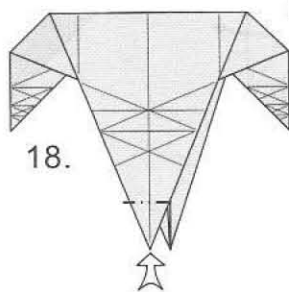
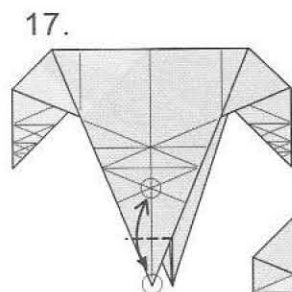
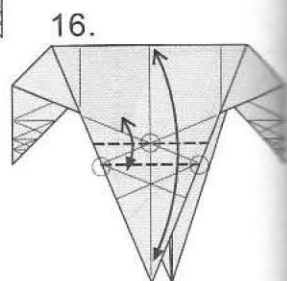
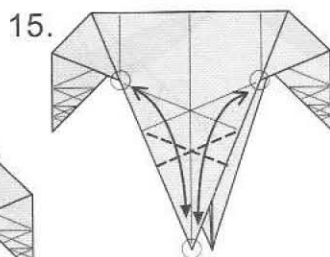
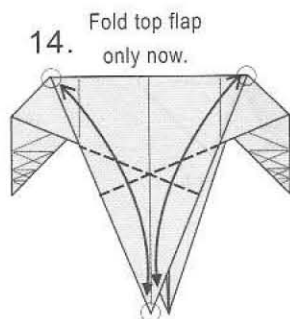

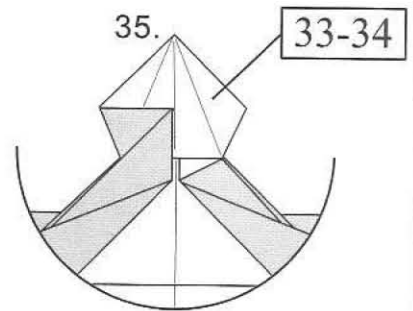
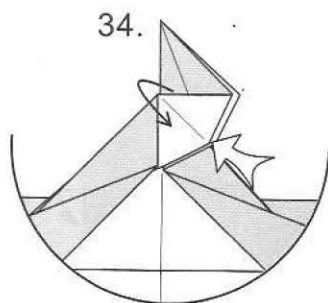
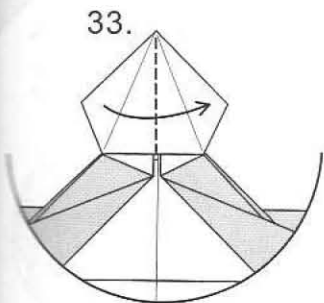
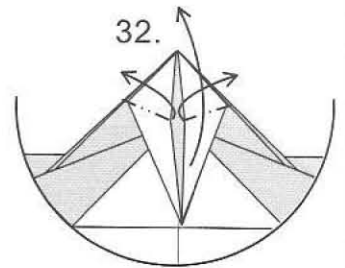
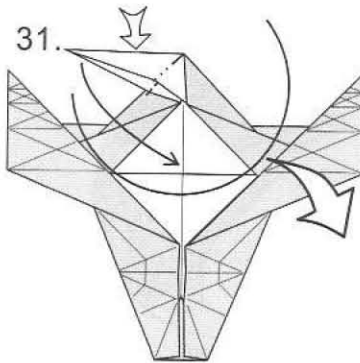
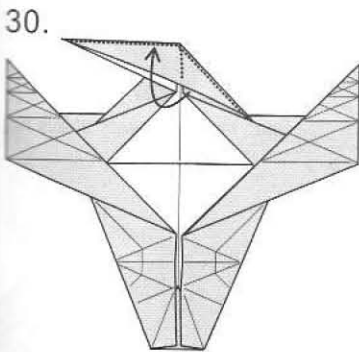
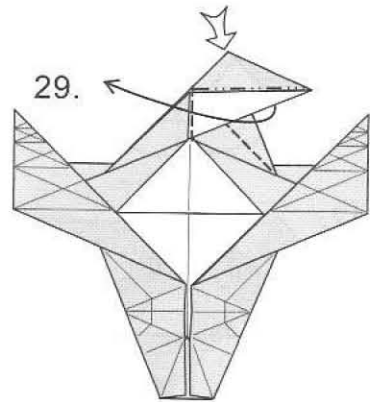
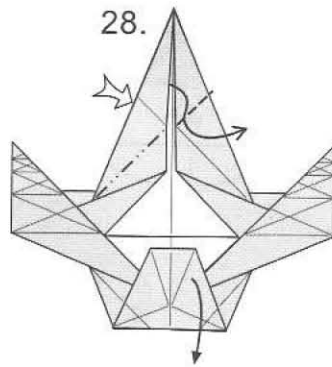
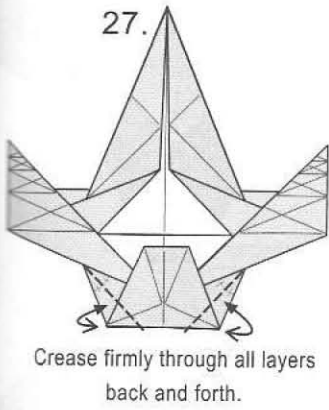
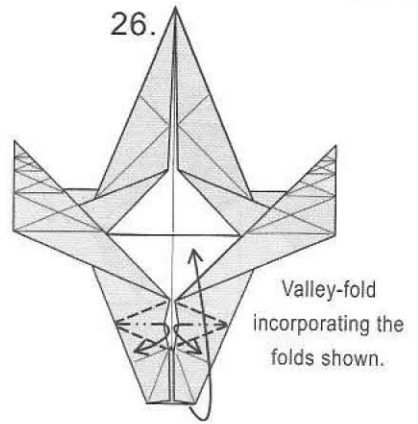
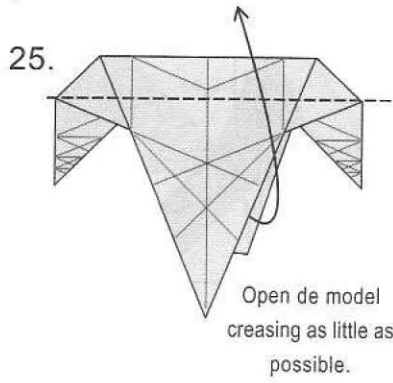
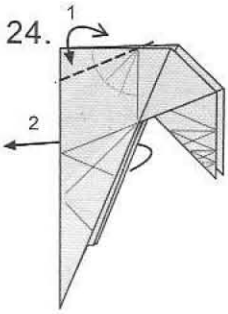

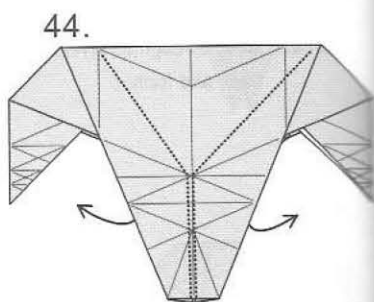
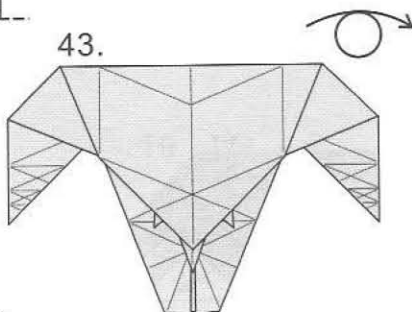
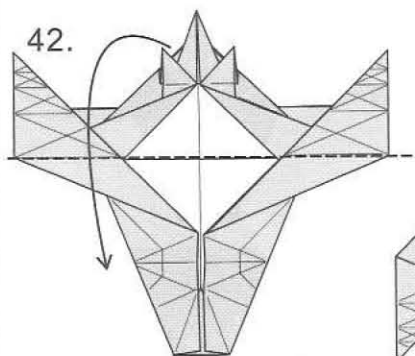
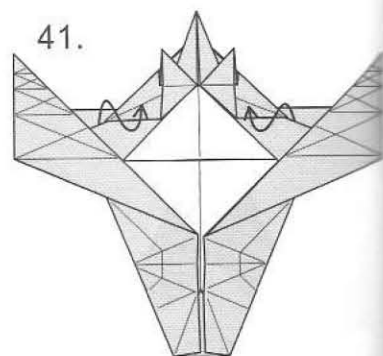
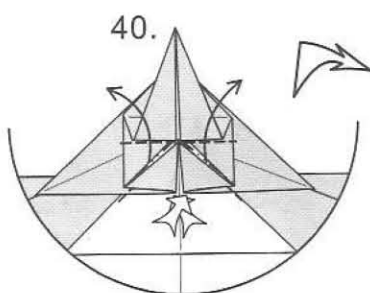
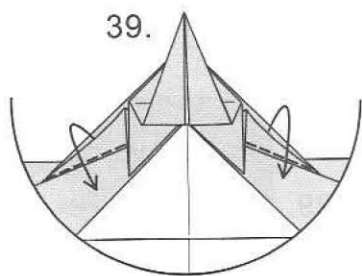
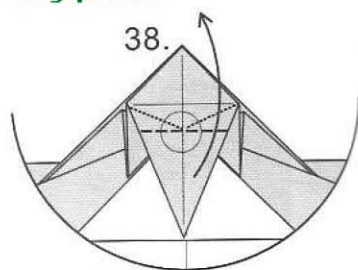
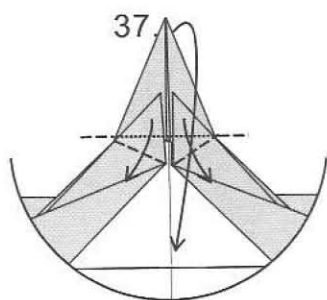
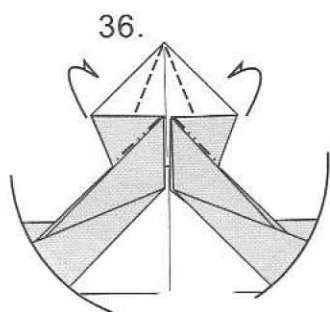

Open the back layers of this flap.
It doesn't lay flat.

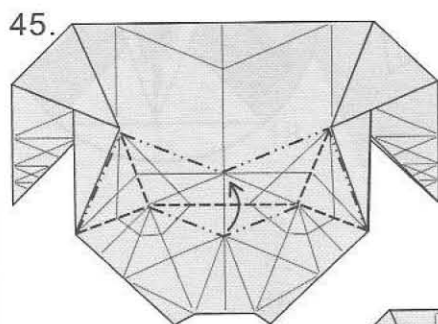

This is a kind of a crimp fold. From this point on it will not be flay again.

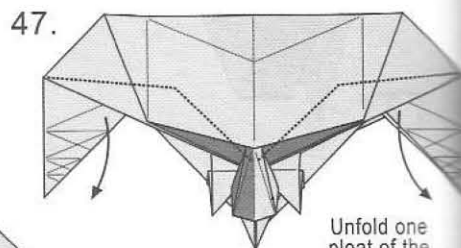
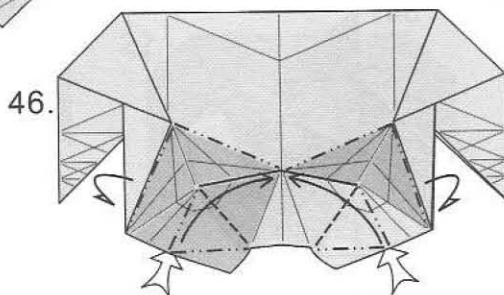

Unfold one pleat of the horns.

A frontal view of the eye after step 46.

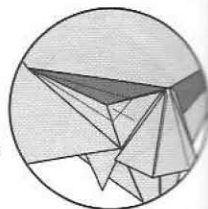

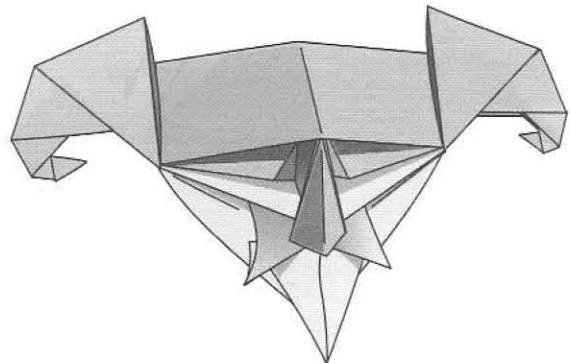
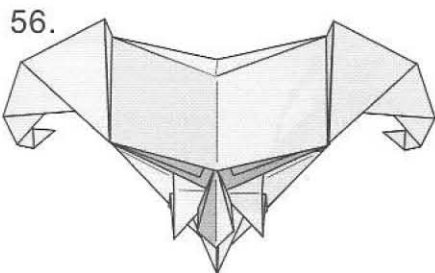
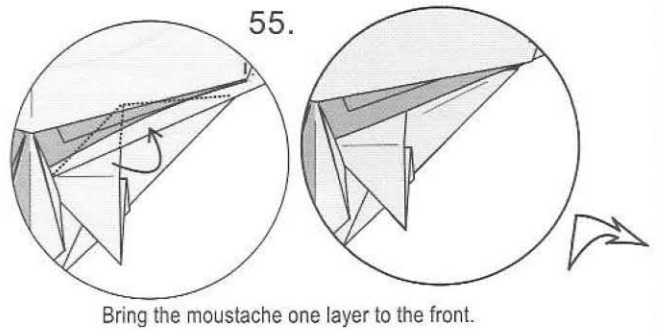
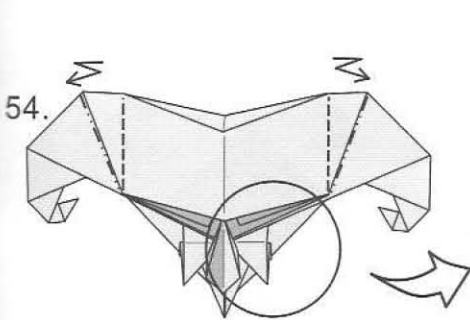
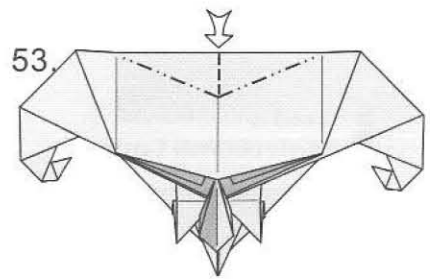
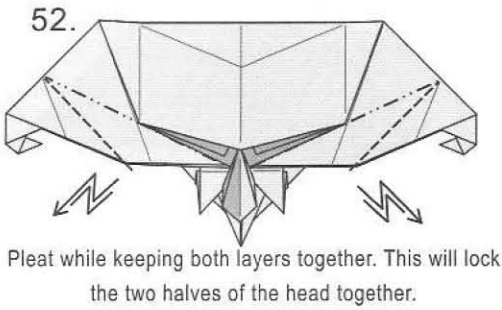
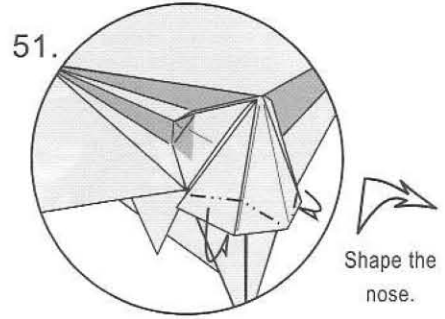
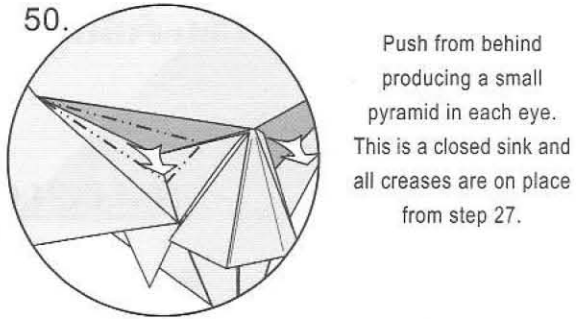
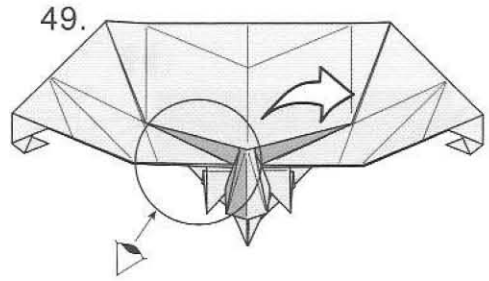
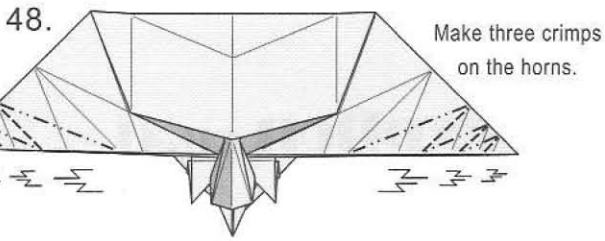

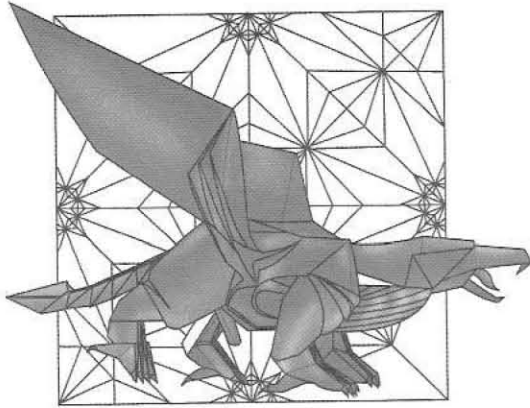

Gryphon op.41

Designed by Andrey Ermakov

Russia / Saint-Petersburg

10.06.2008

Recommended size 50-50 cm

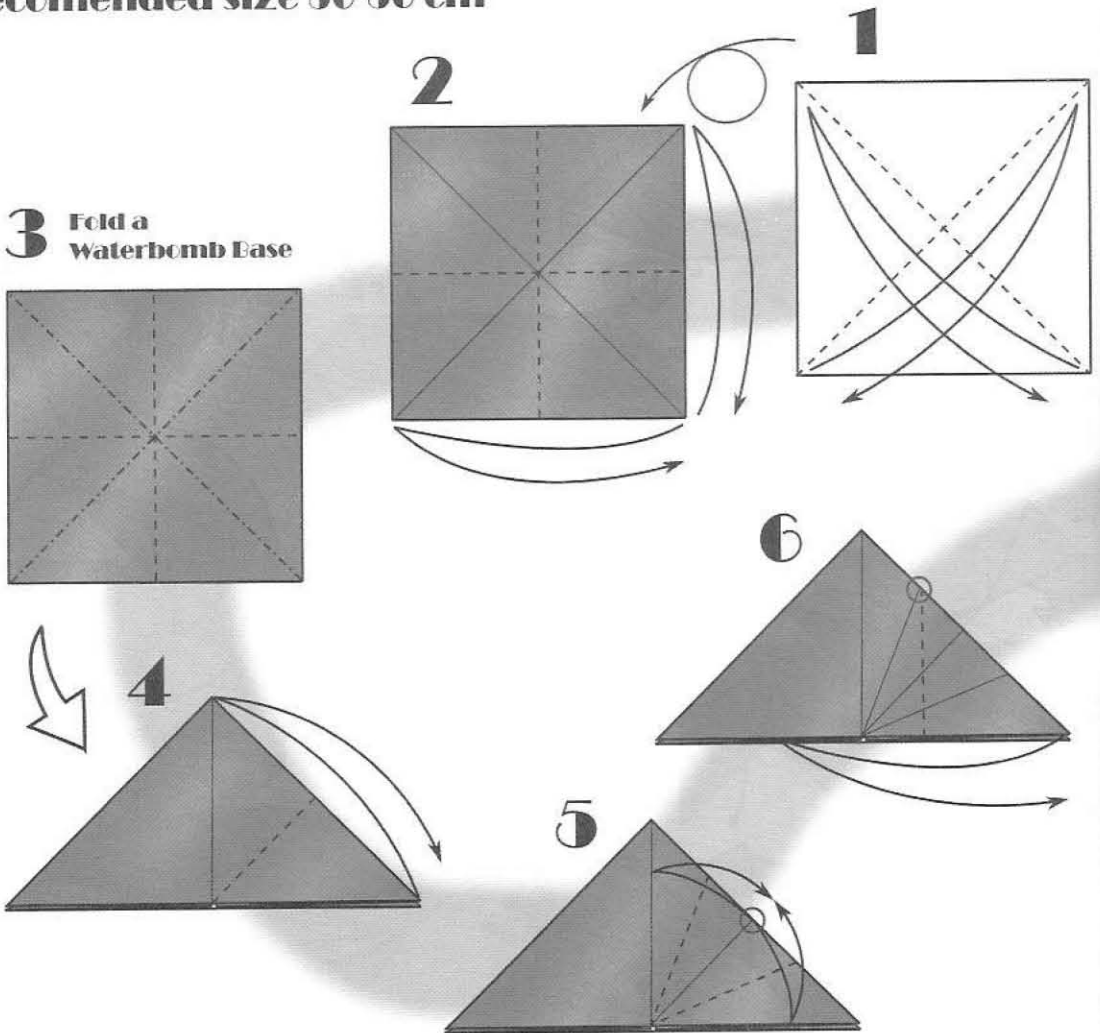

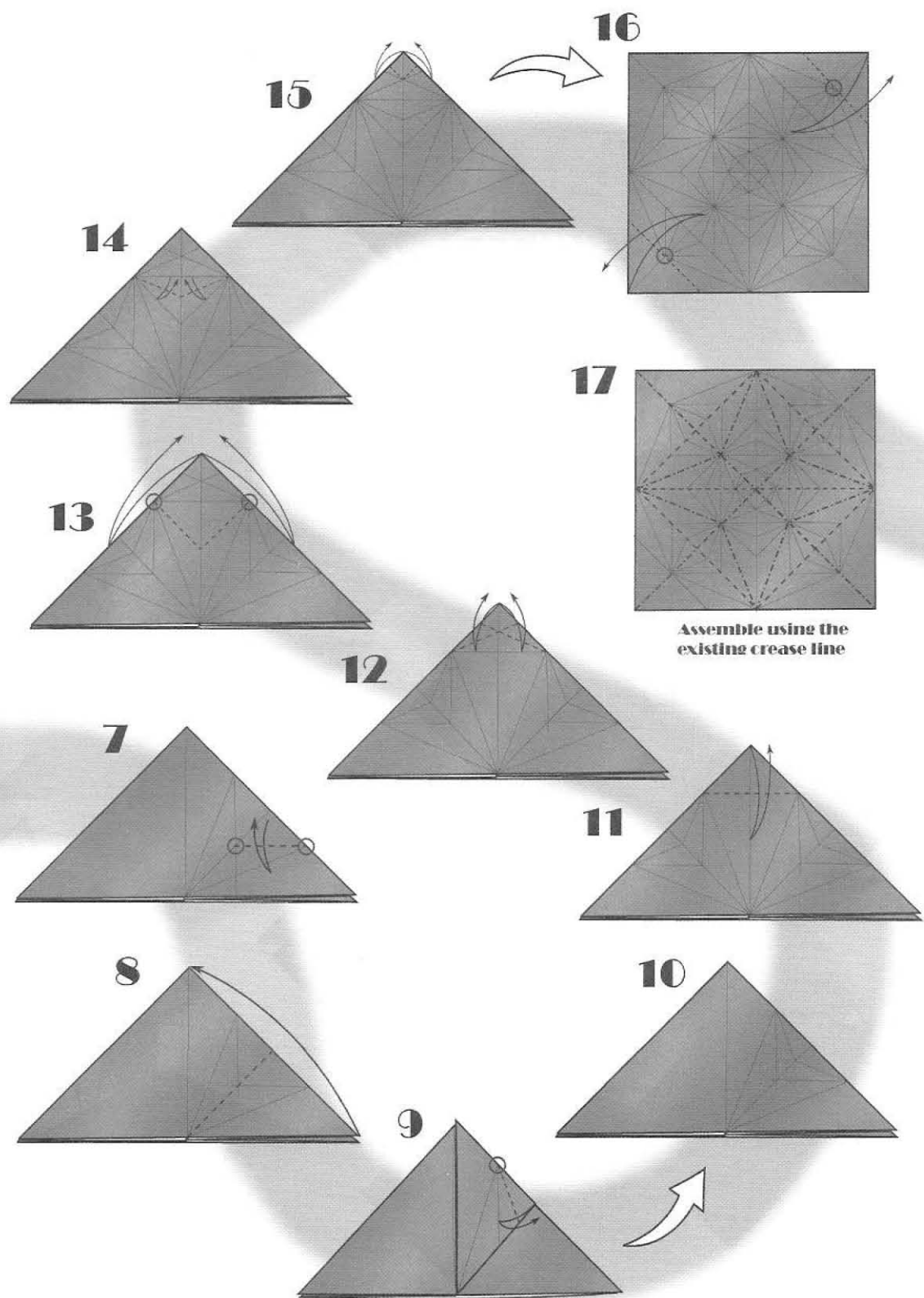

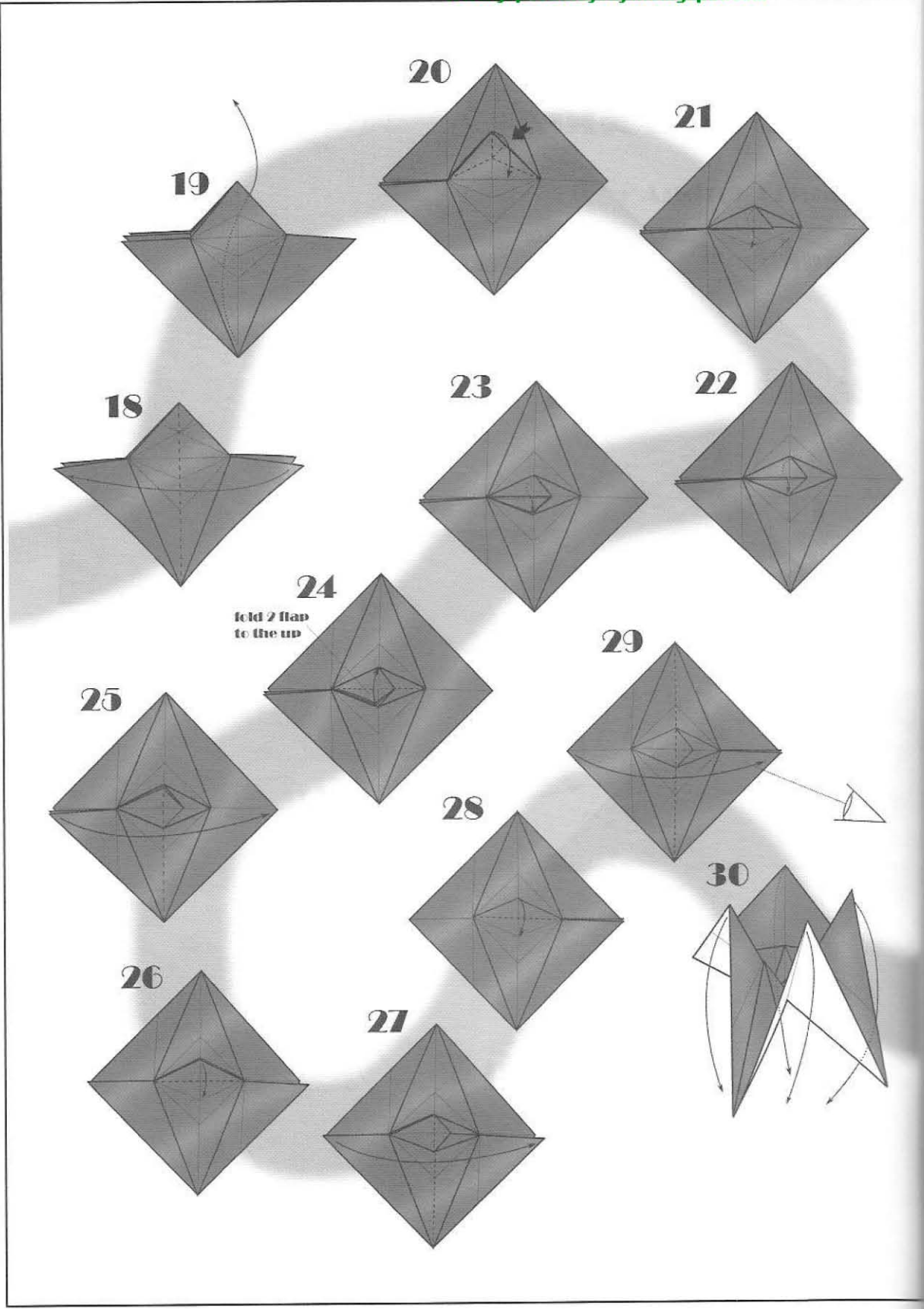

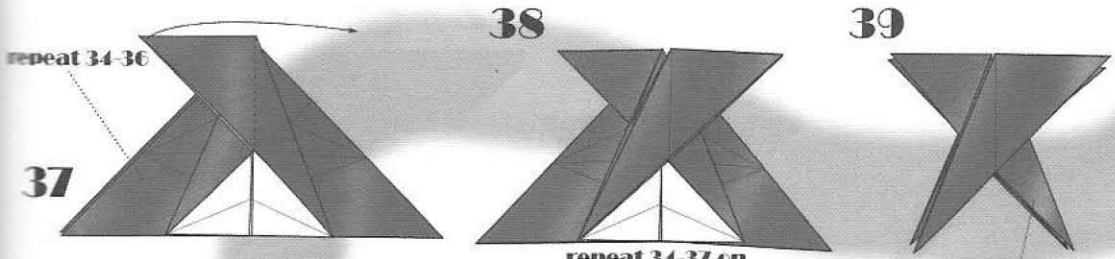

repeat 34-37 on the back side

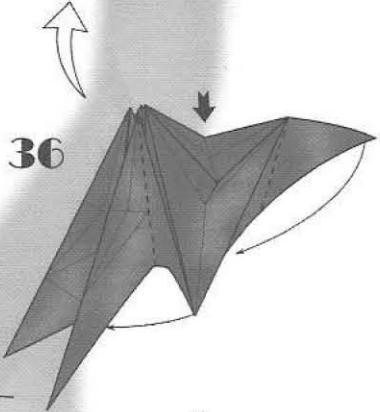

36

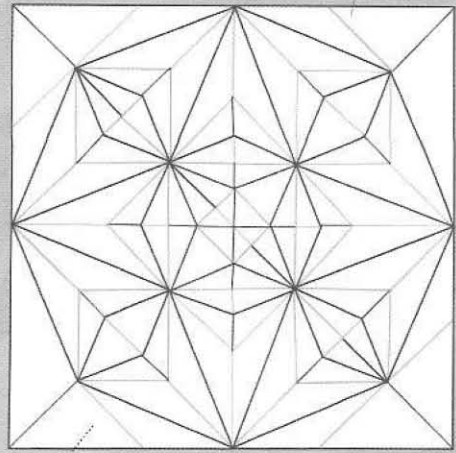

crease pattern after 39 steps

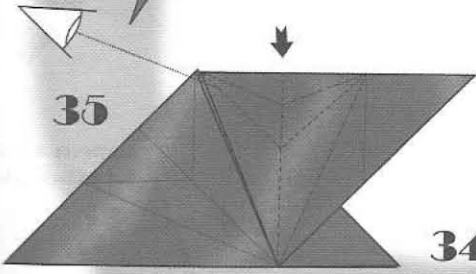

35

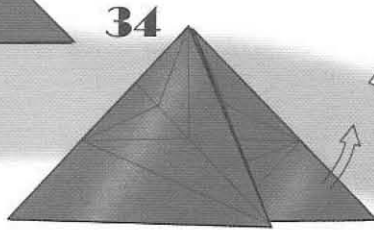

34

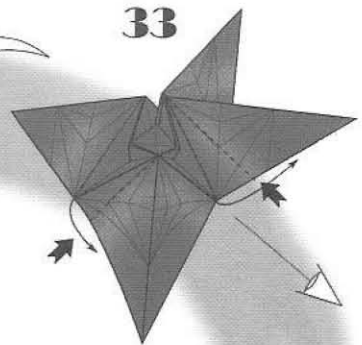

33

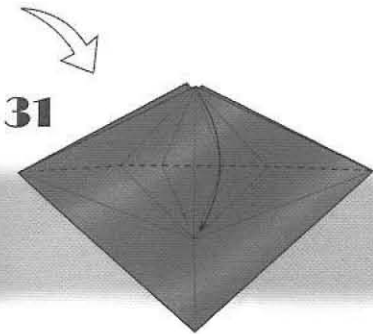

31

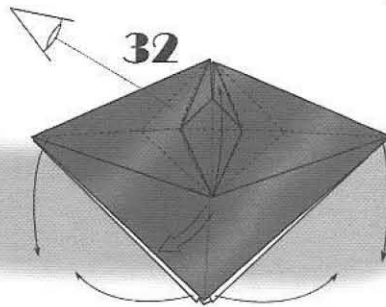

32

40

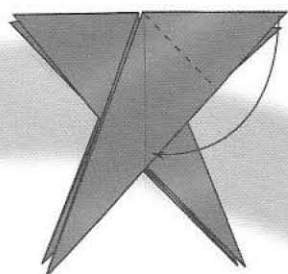

41

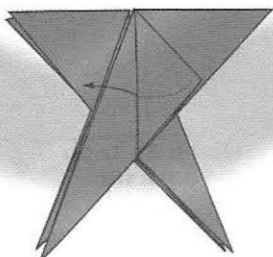

42

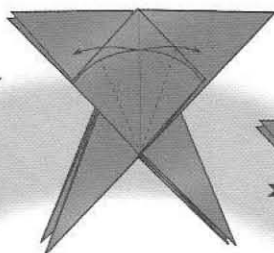

43

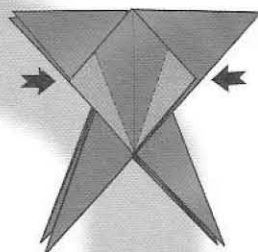

46

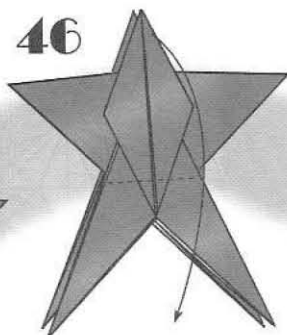

Repeat 40-44 behind

45

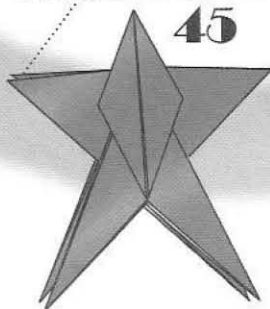

44

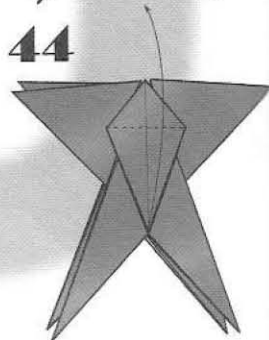

47

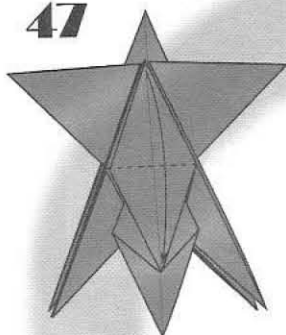

Repeat 49-51
for other wing

49

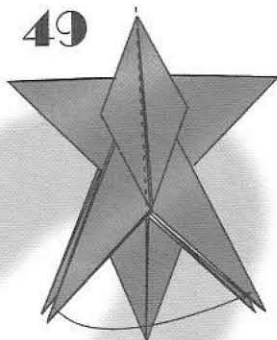

52

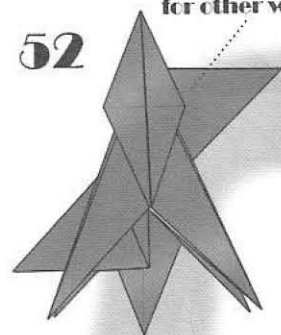

48

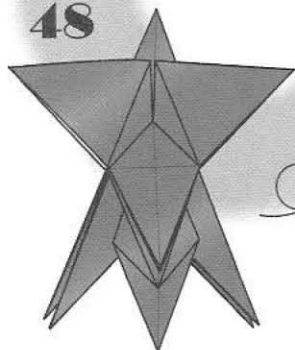

50

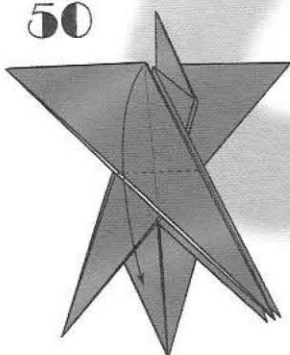

51

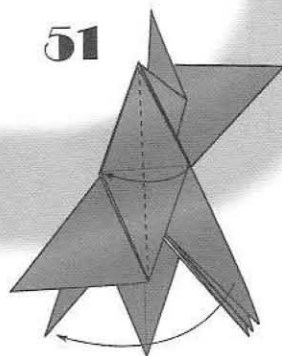

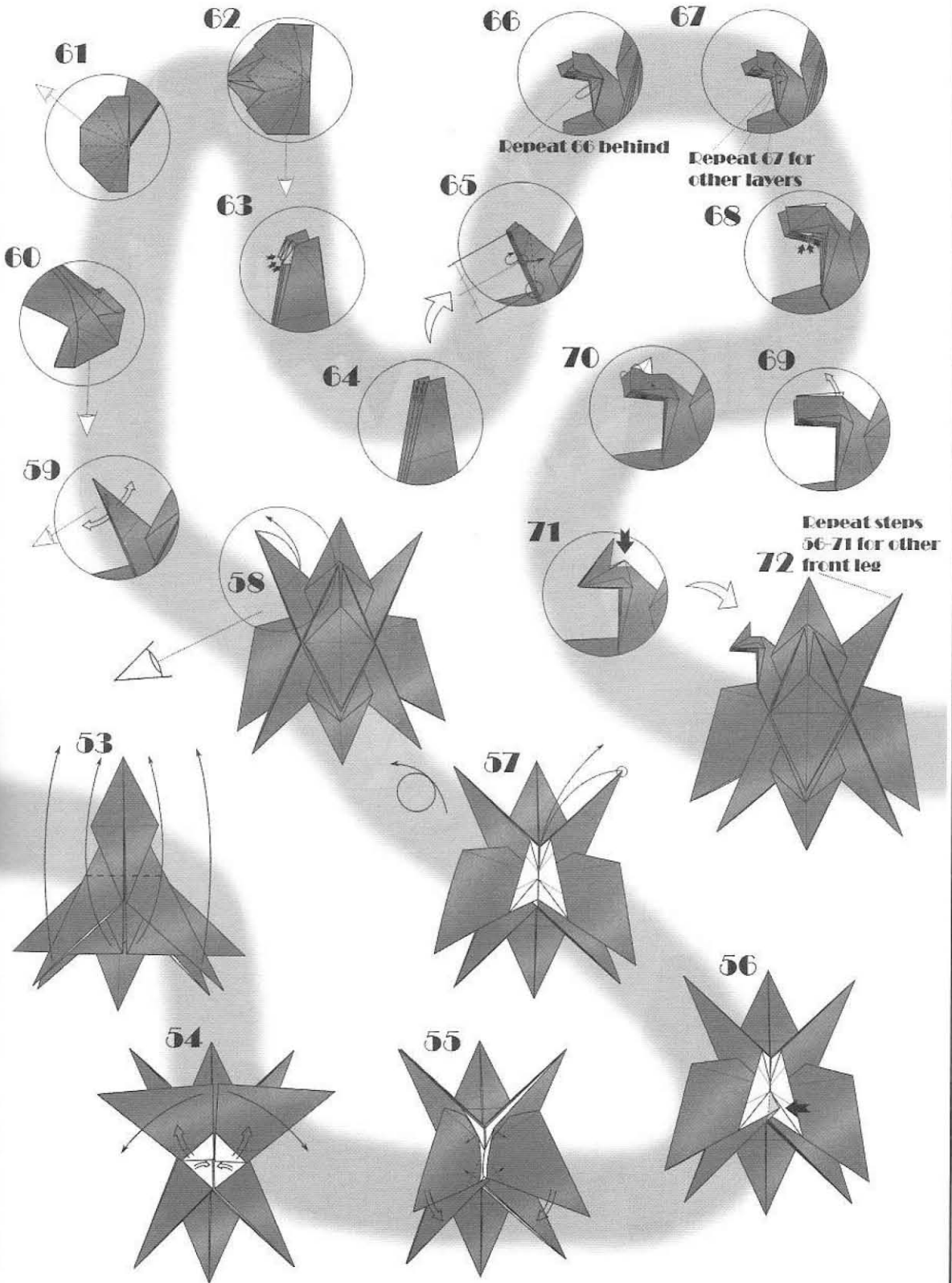

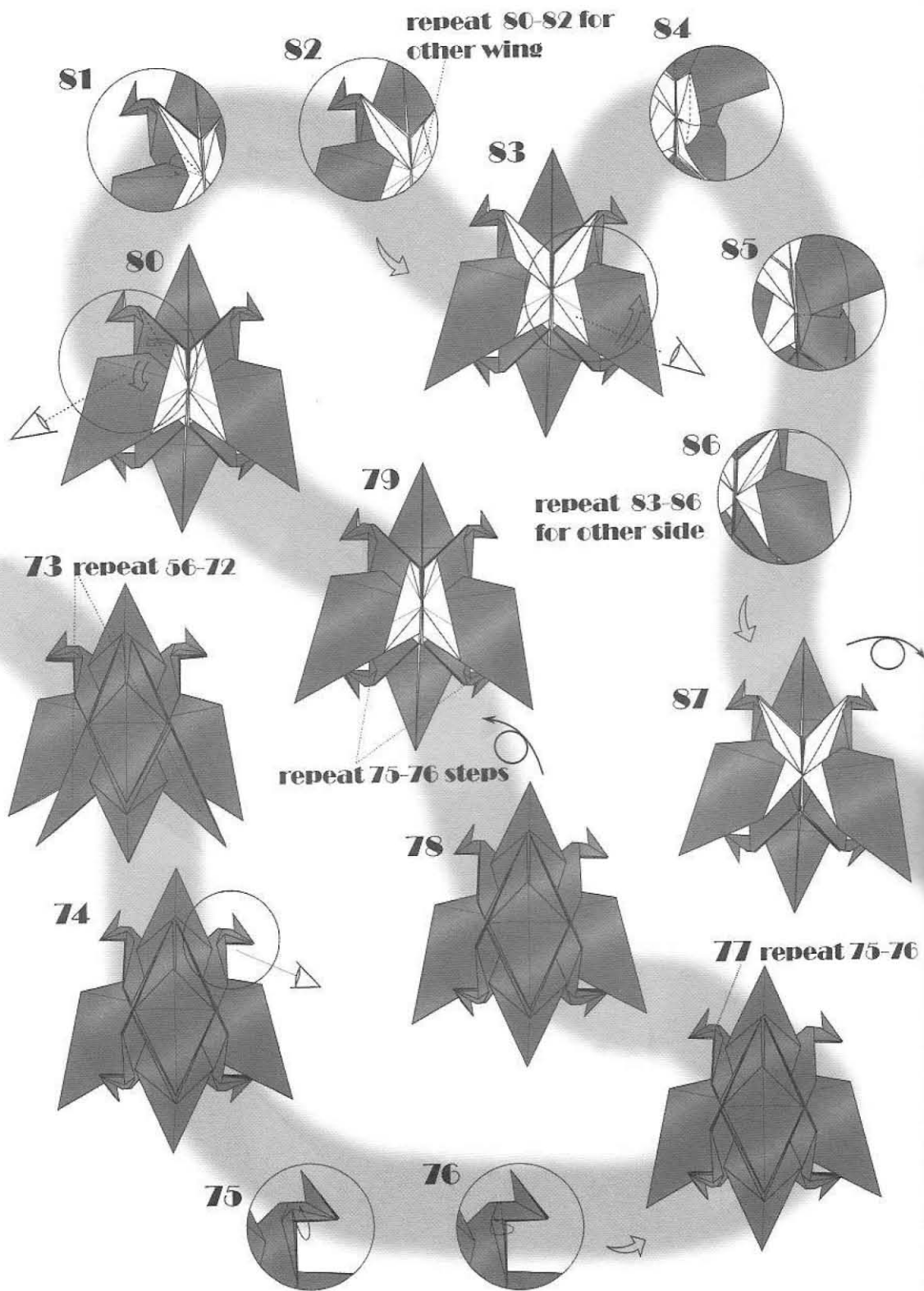

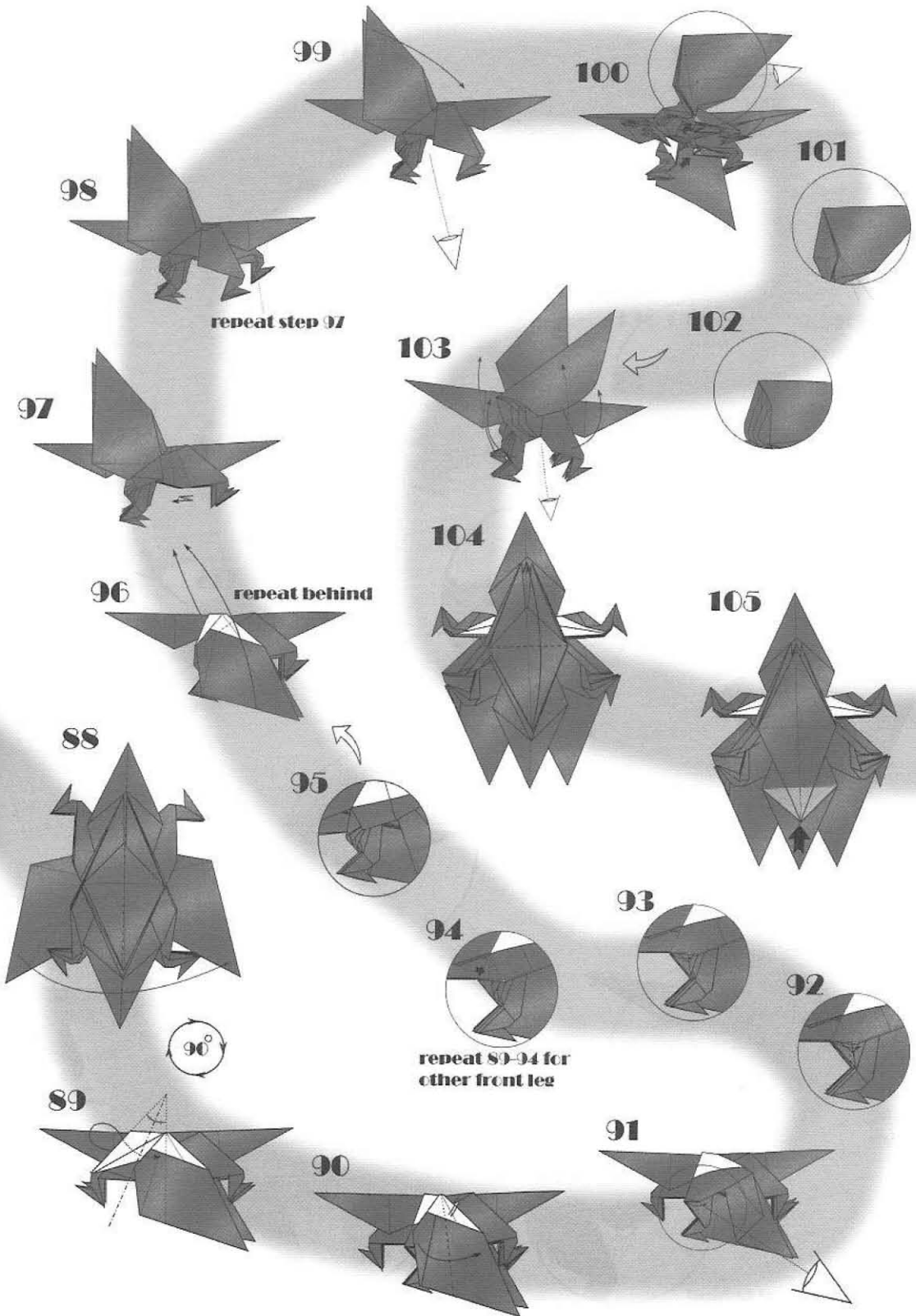

114

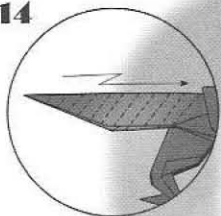

115

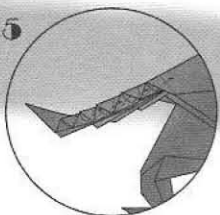

116

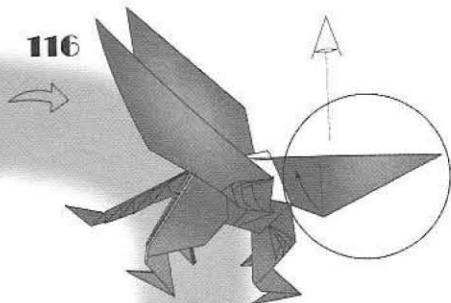

113

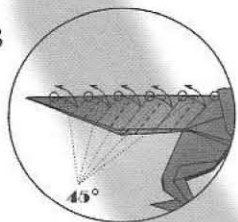

117

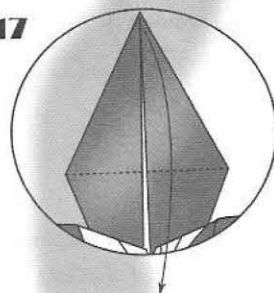

106

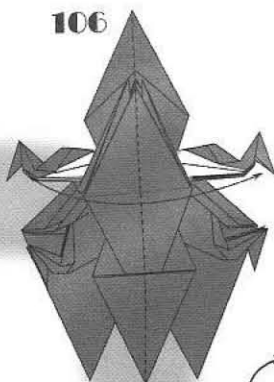

112

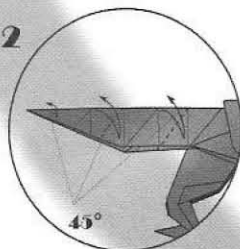

118

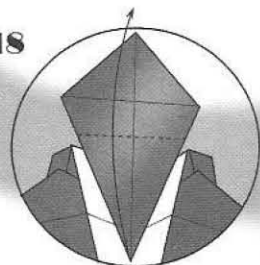

111

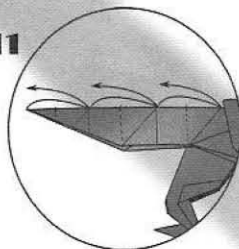

107

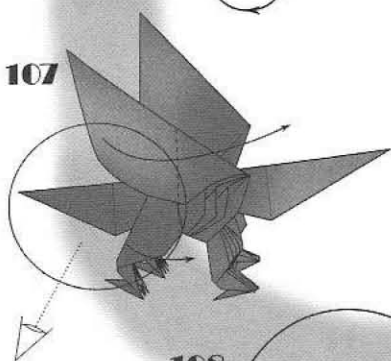

110

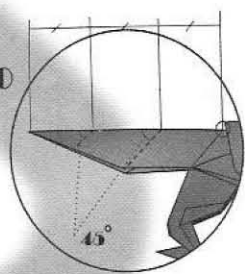

108

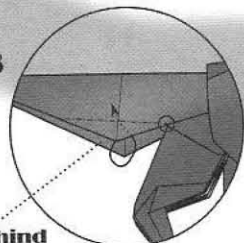

109

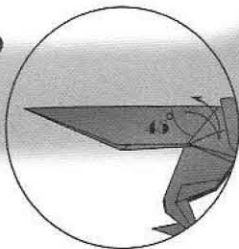

126

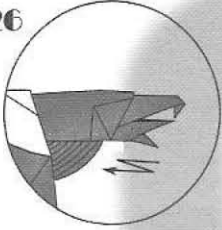

127

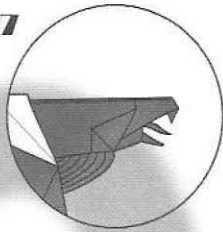

125

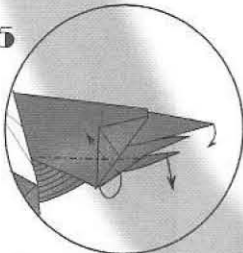

Repeat 122-125
behind

119

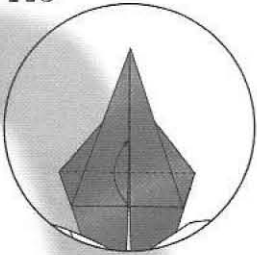

128

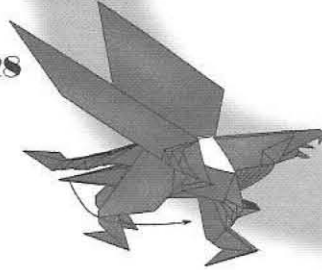

129

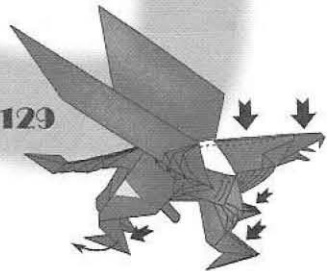

make 3-D shape

123

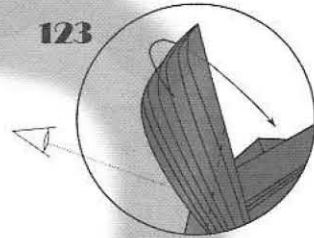

120

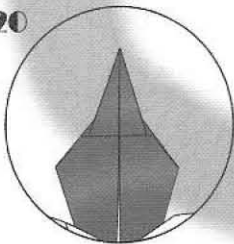

121

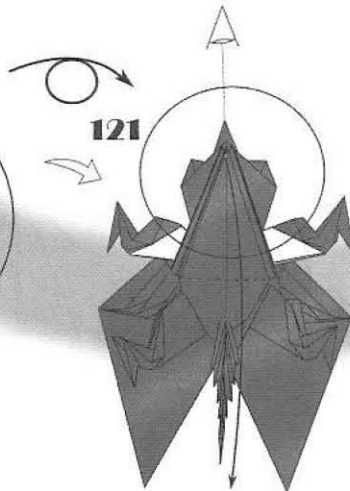

122

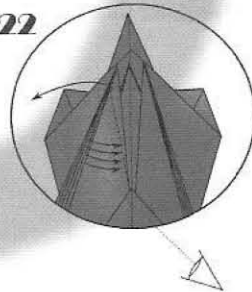

130 Gryphon completed

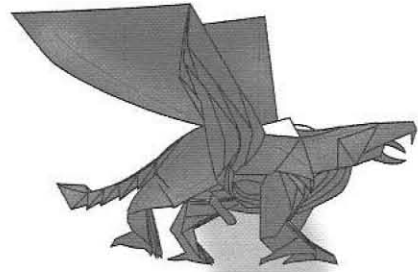



El papel puede ser de color verde o pardo.
Se recomienda 40x40 cm metalizado o
doble seda, menor de 30 gr/m2.

An appropriate color for paper would be
green.

It is recommended size of 40 x40 cm or
bigger and weight slighther than 30
gr/m2

0.4

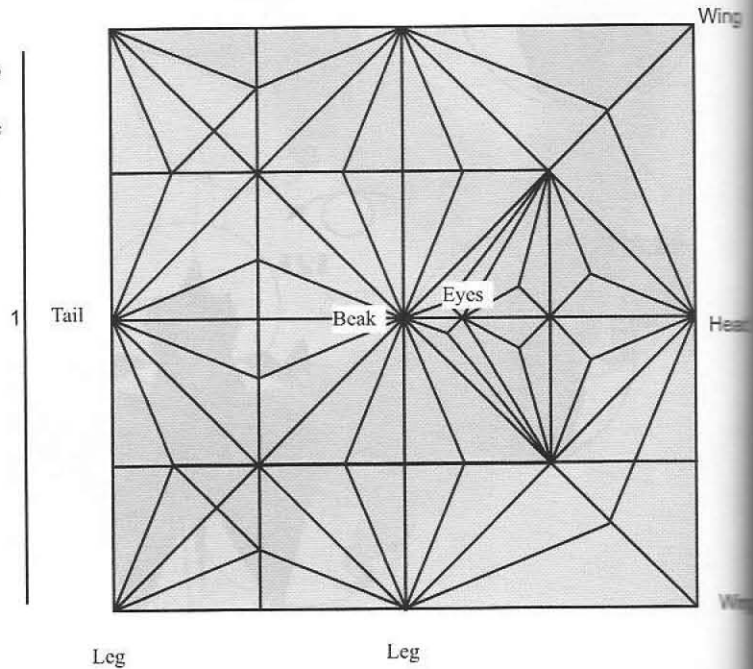
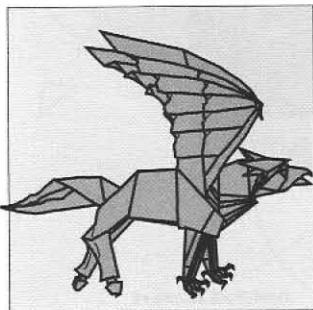

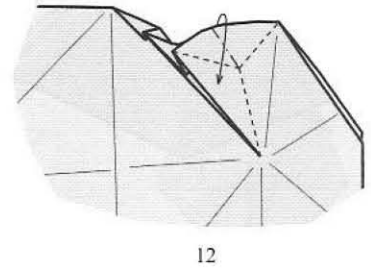
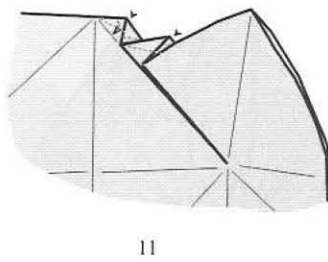
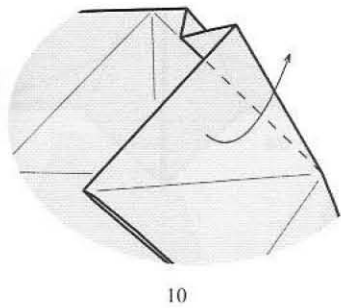
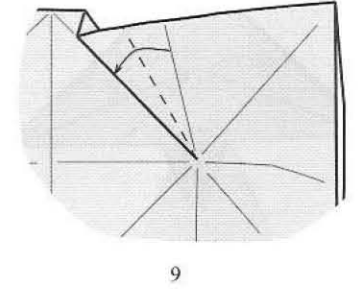
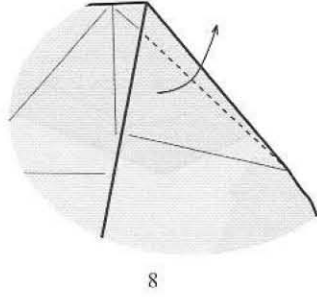
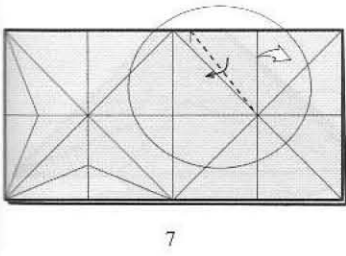
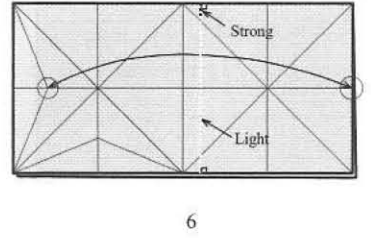
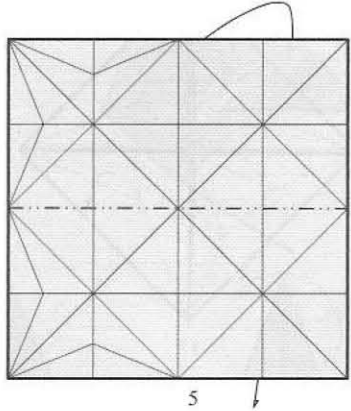
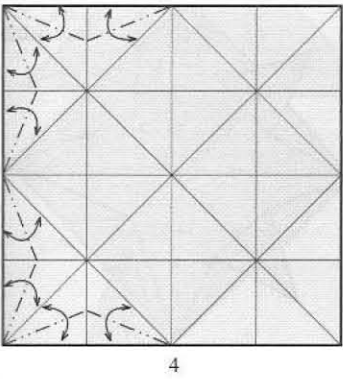
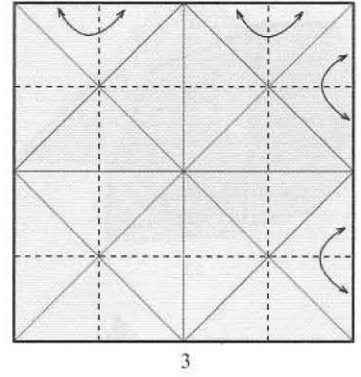
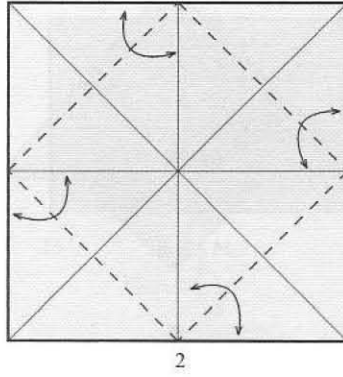
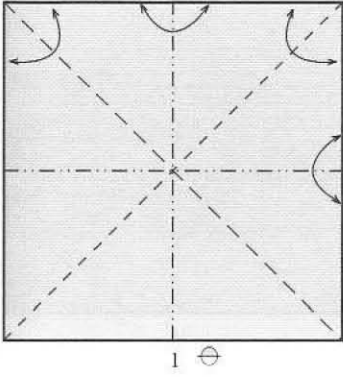

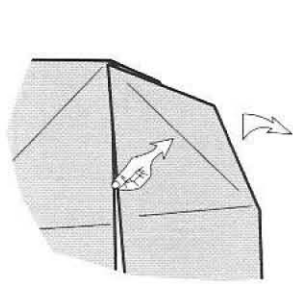

13

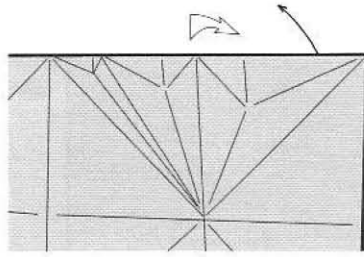

14

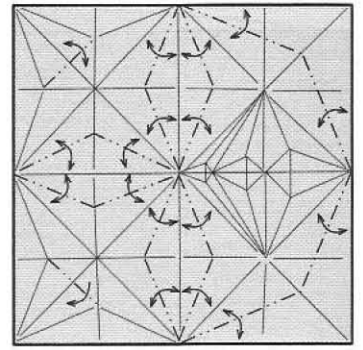

15

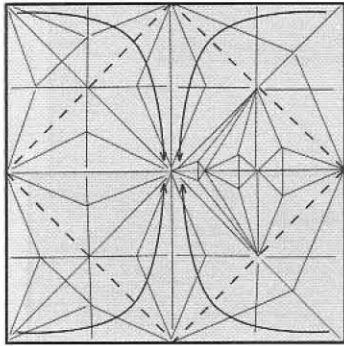

16

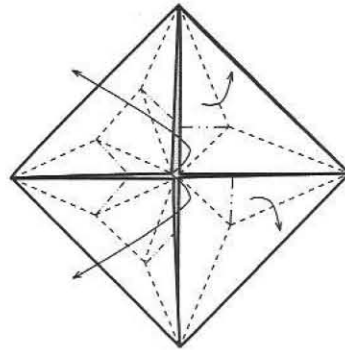

17

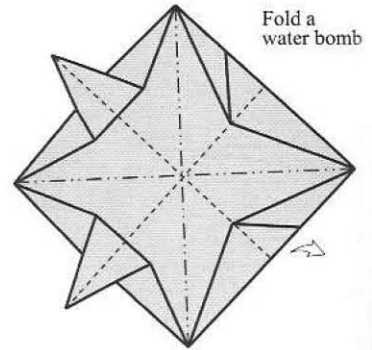

18

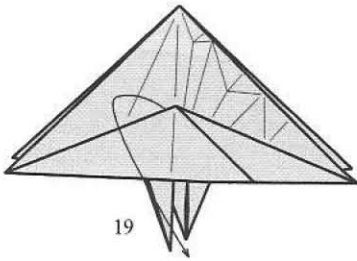

19

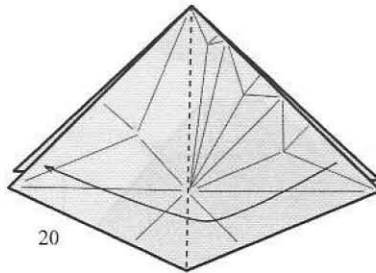

20

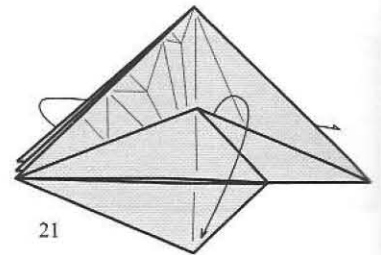

21

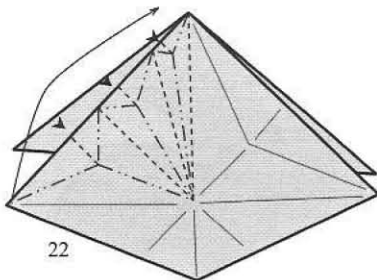

22

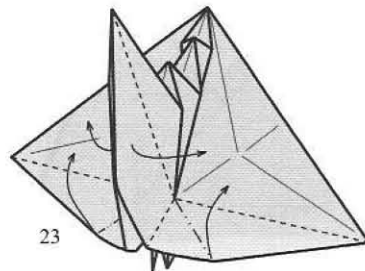

23

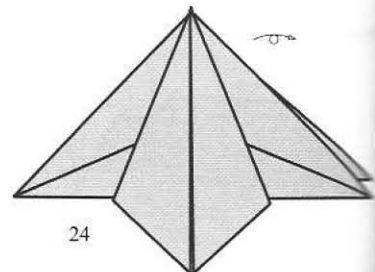

24

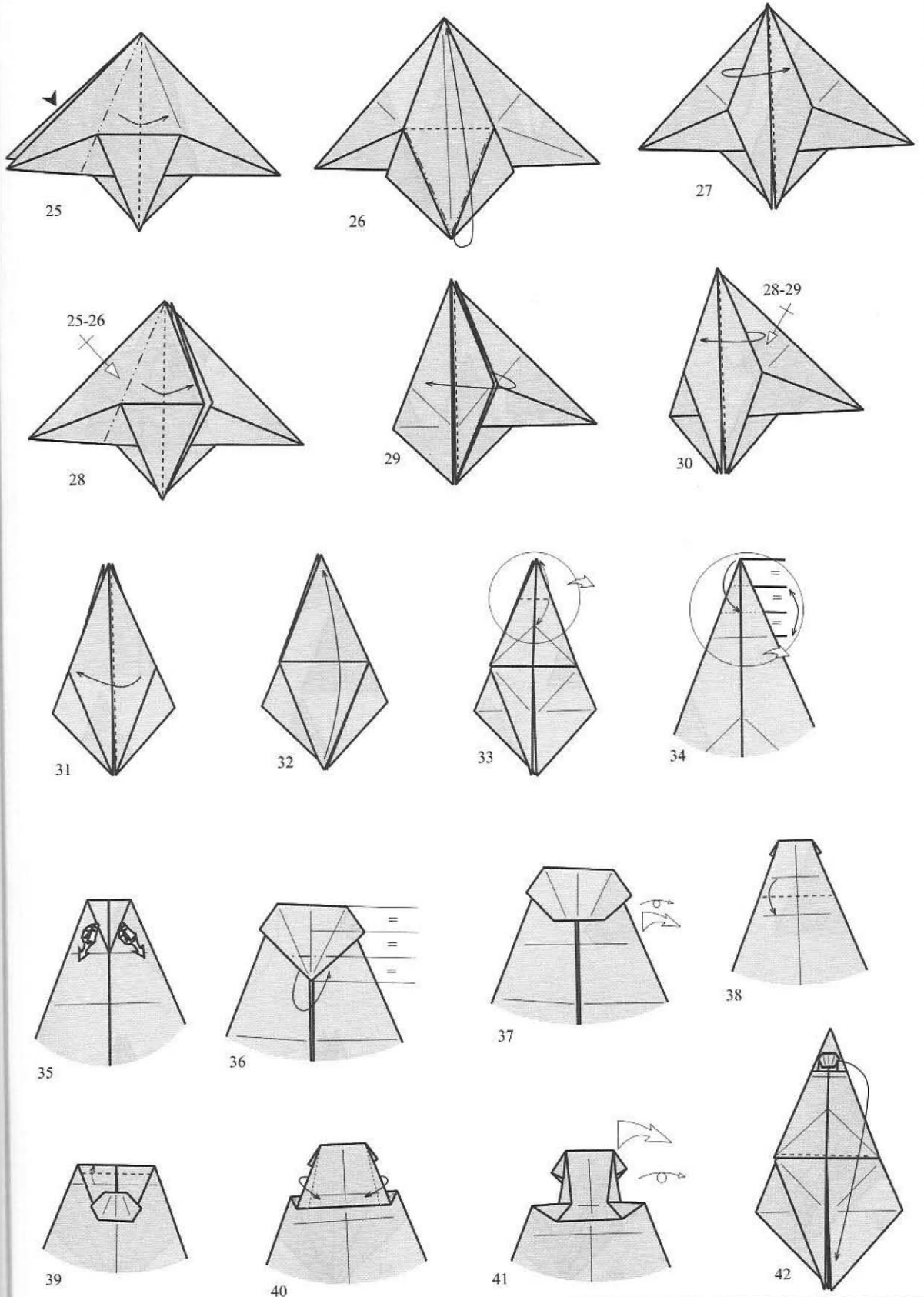

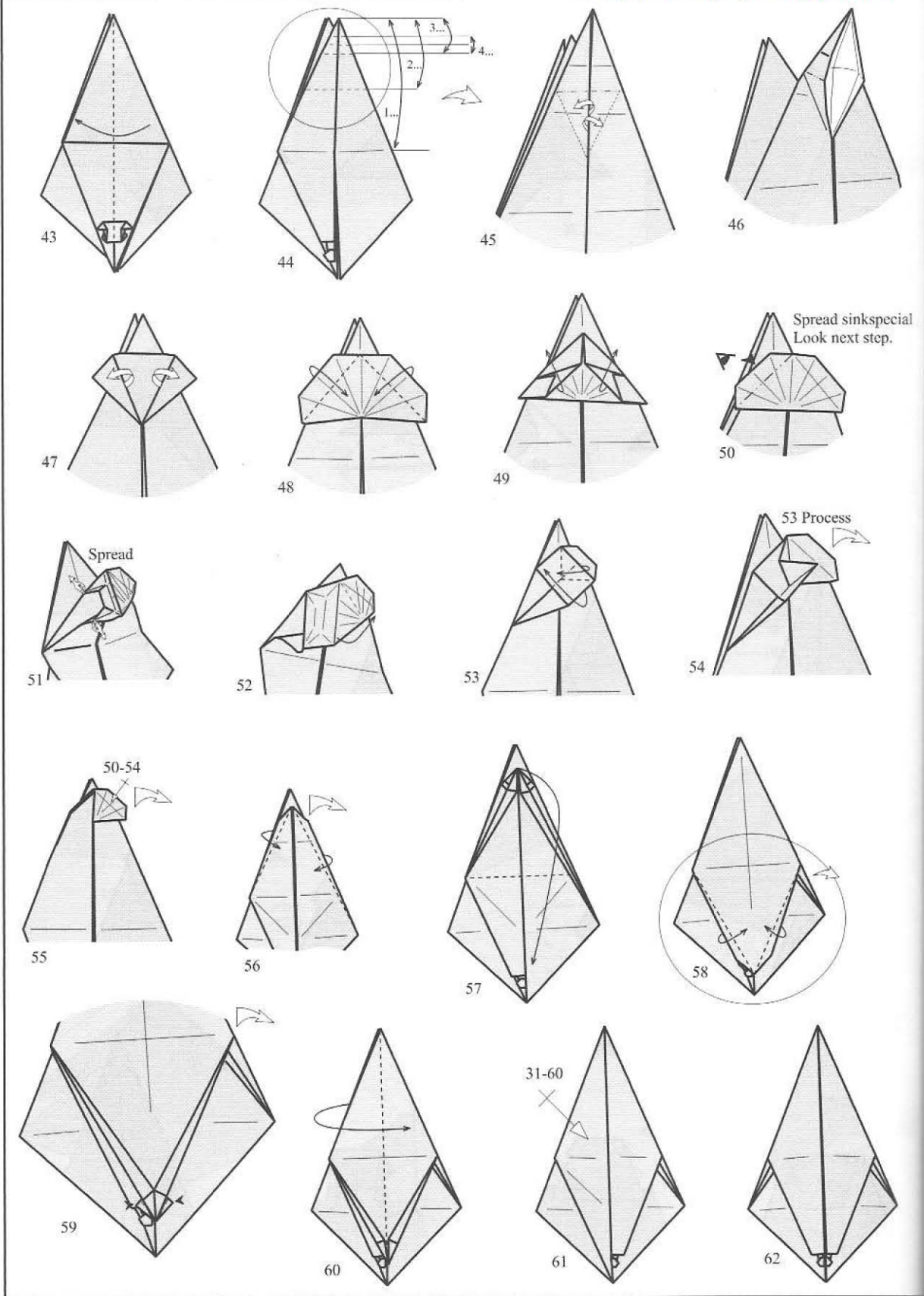

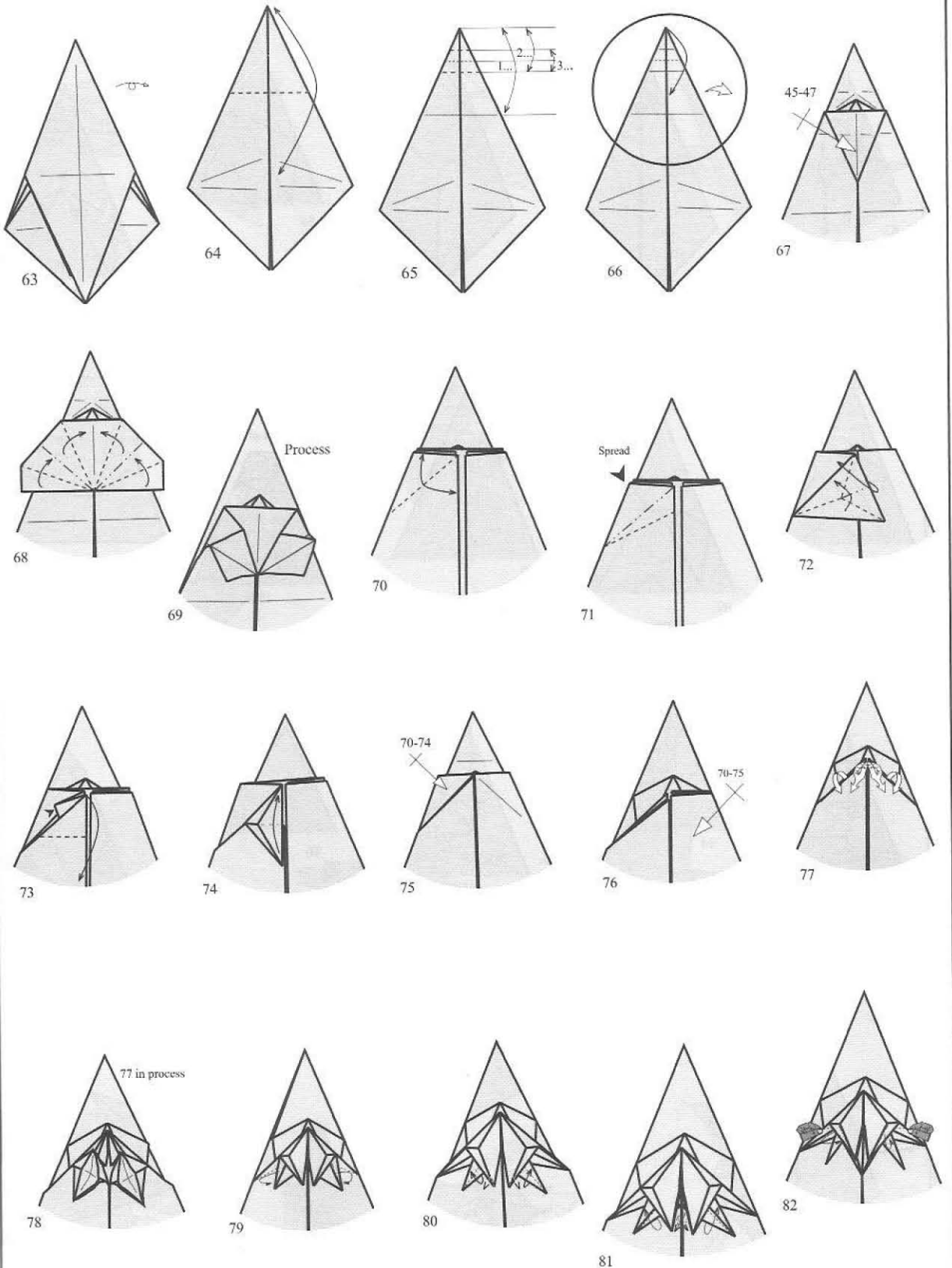

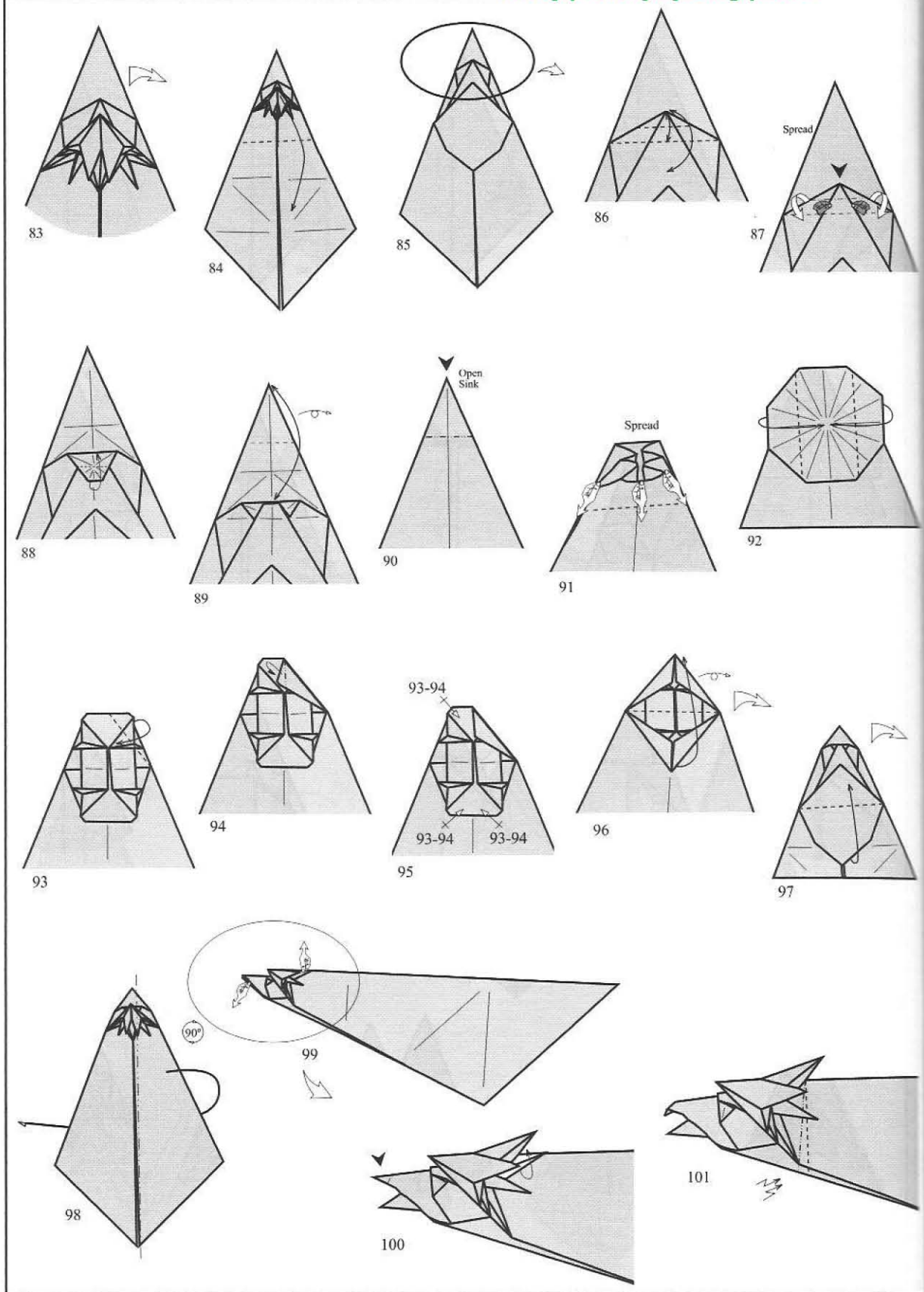

On the next steps, I draw the head only if necessary

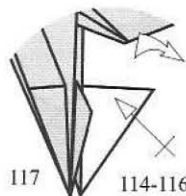
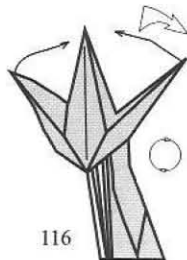
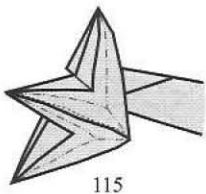
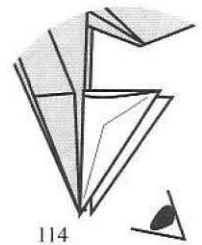
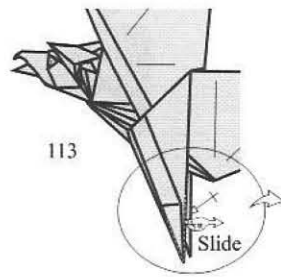
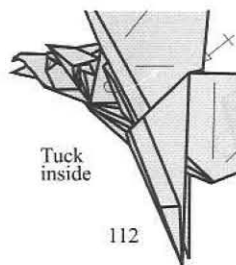
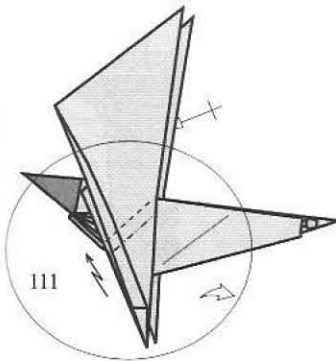
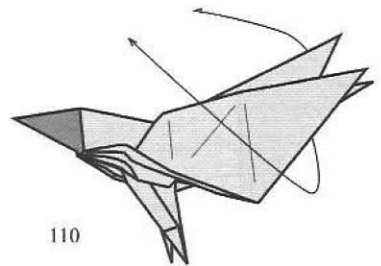
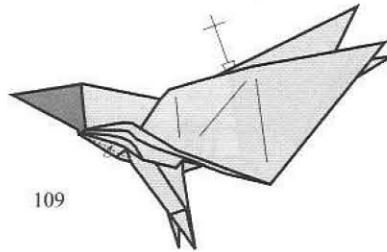
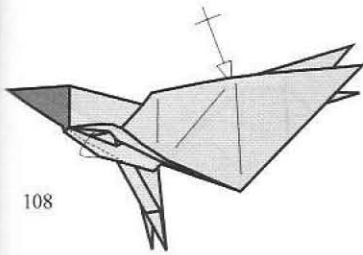
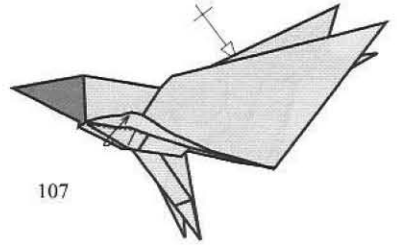
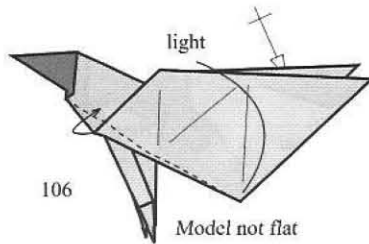
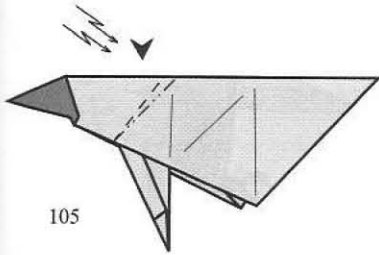
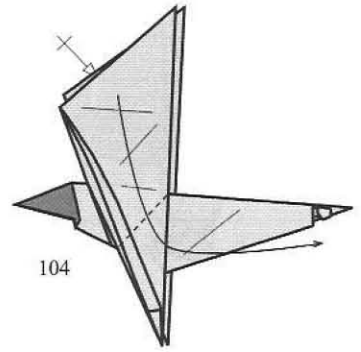
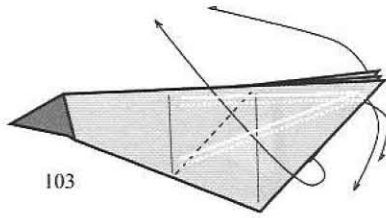
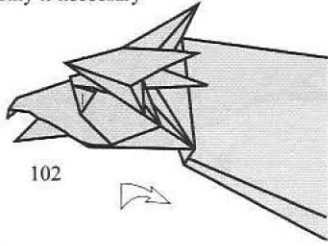

114-116

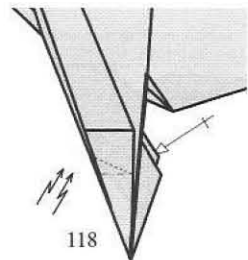

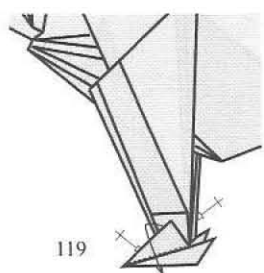

119

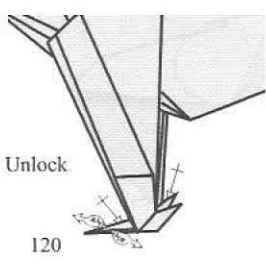

Unlock

120

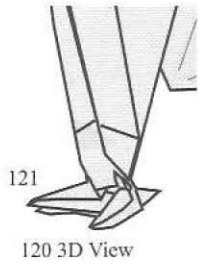

121

120 3D View

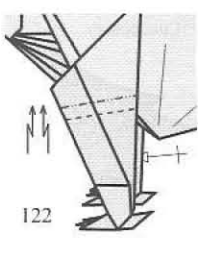

122

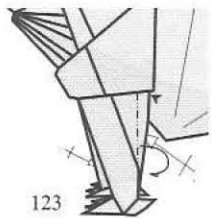

123

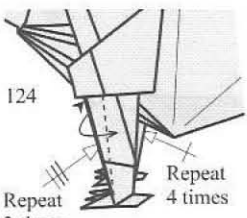

124

Repeat 3 times

Repeat 4 times

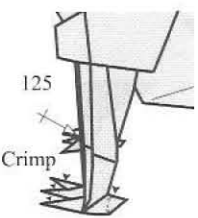

125

Crimp

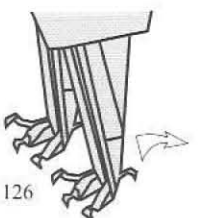

126

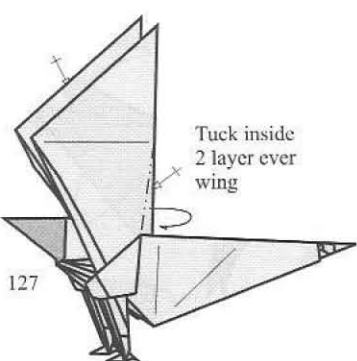

Tuck inside 2 layer ever wing

127

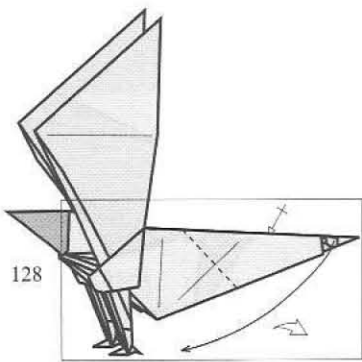

128

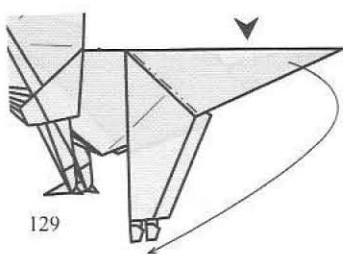

129

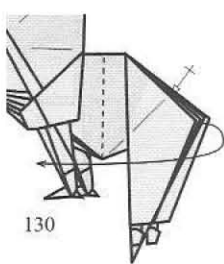

130

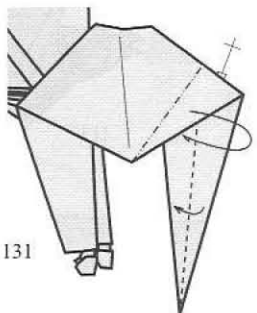

131

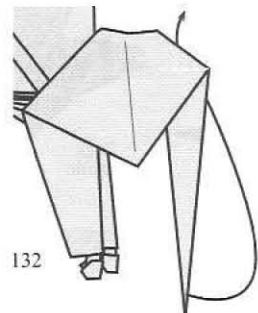

132

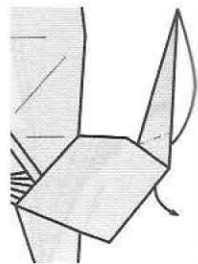

133

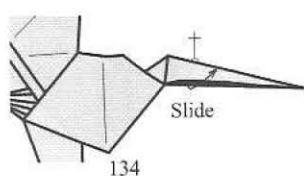

Slide

134

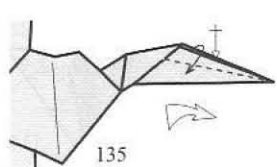

135

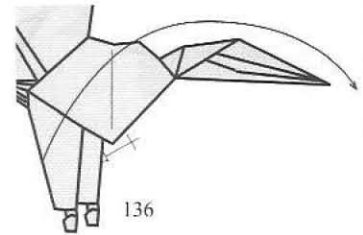

136

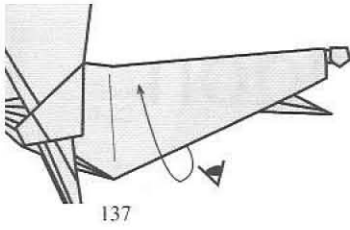

137

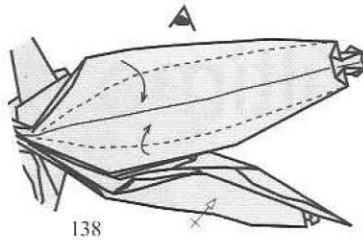

138

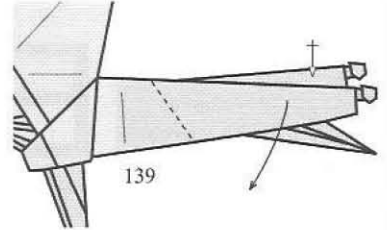

139

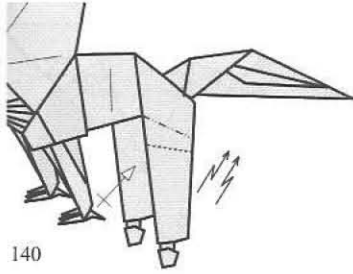

140

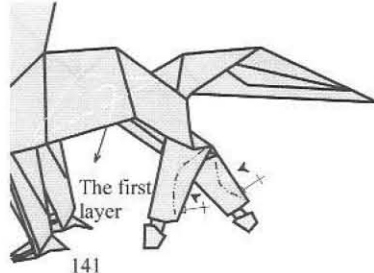

141

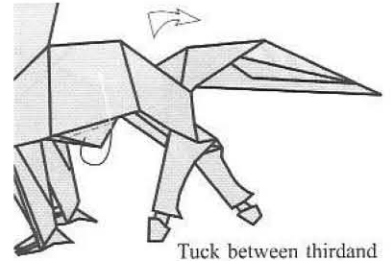

142

Tuck between third and fourth layers. This locks the model for under.

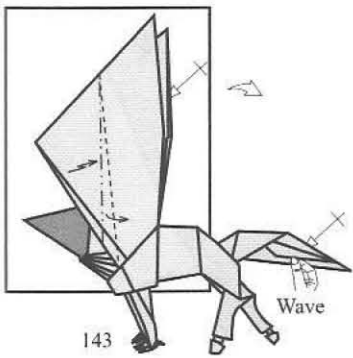

143



144

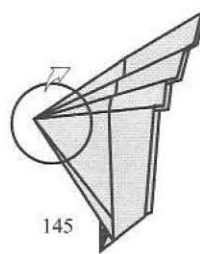

145

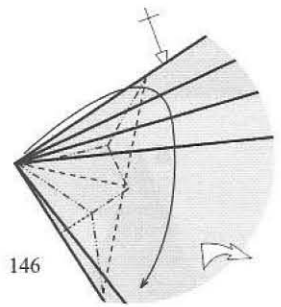

146

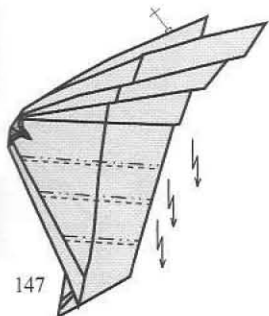

147

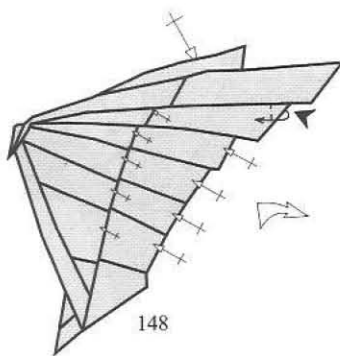

148

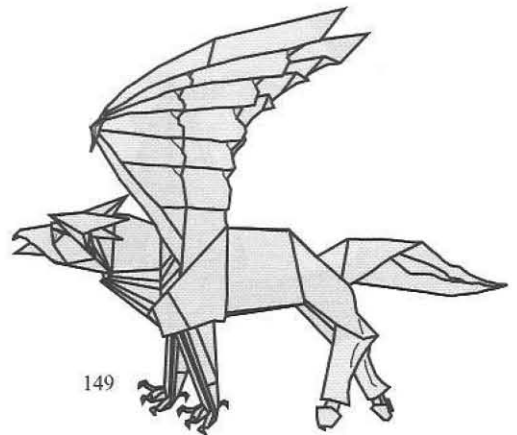

149

El último dragón

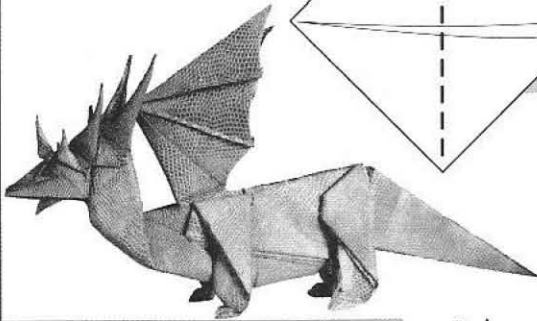

DIFUCULTAD:

Fernando Gilgado
(Spain) 2007
effernan3@hotmail.es

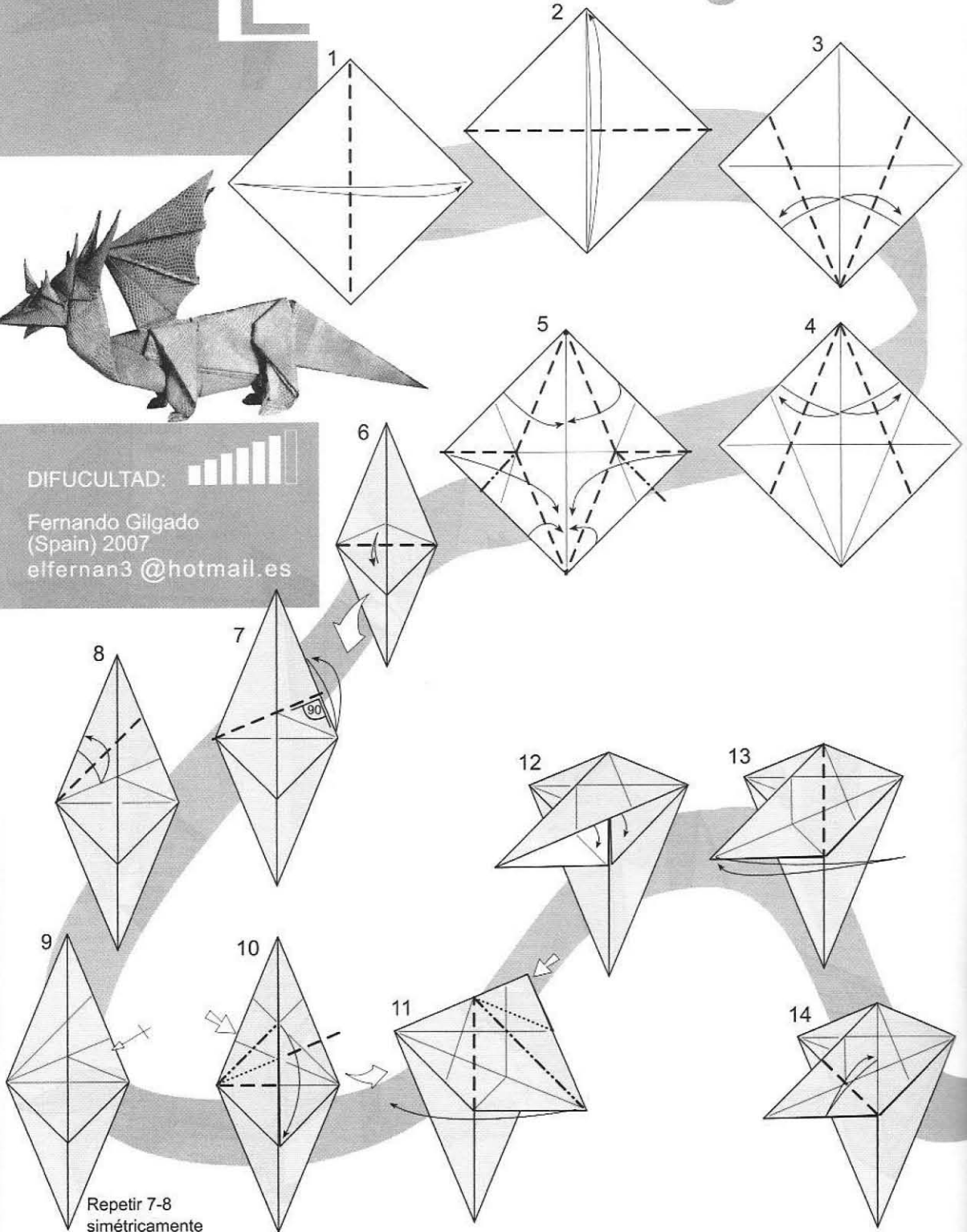

Repetir 7-8
simétricamente

Japão Burajirujin

www.japaoburajirujin.blogspot.com

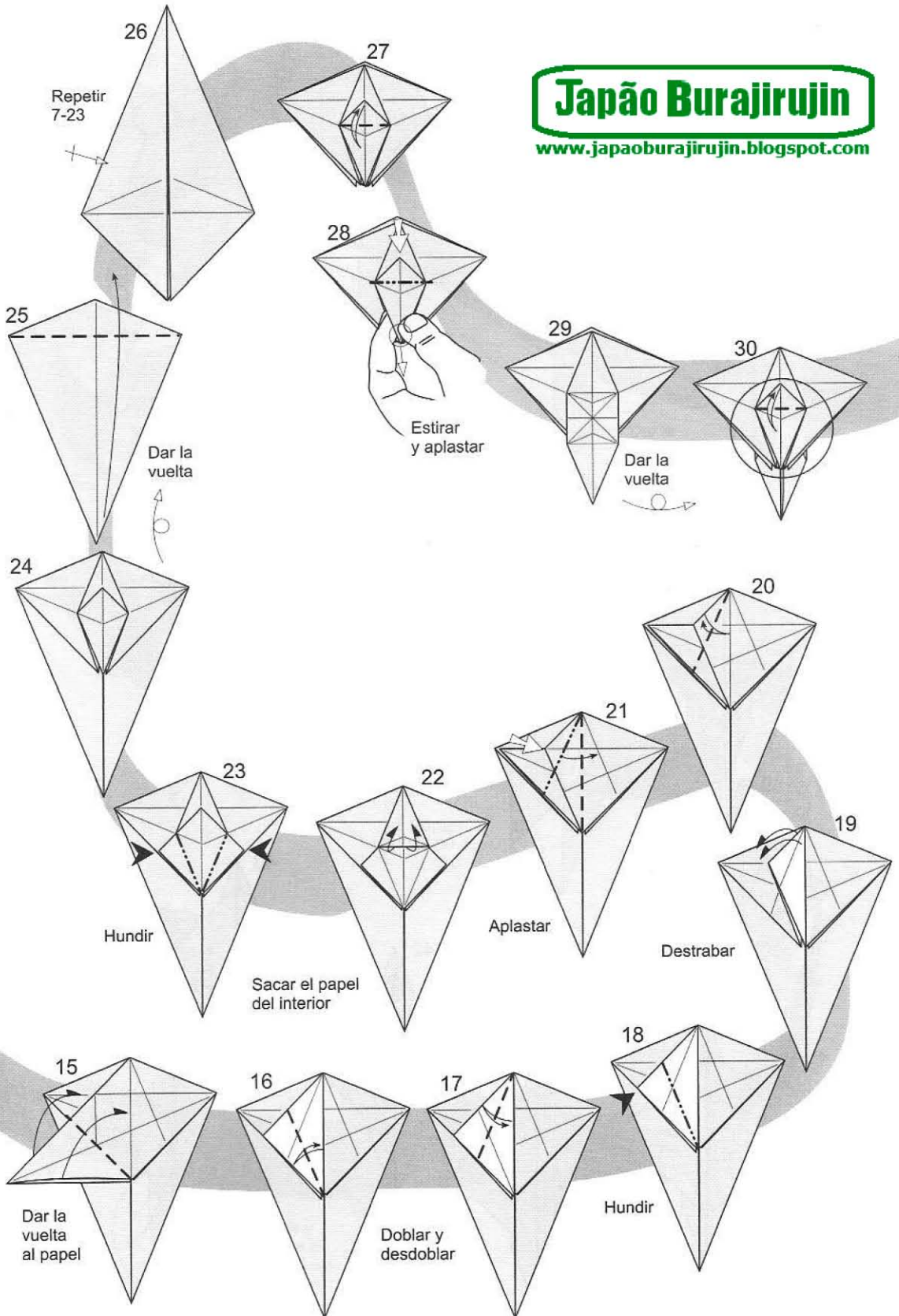

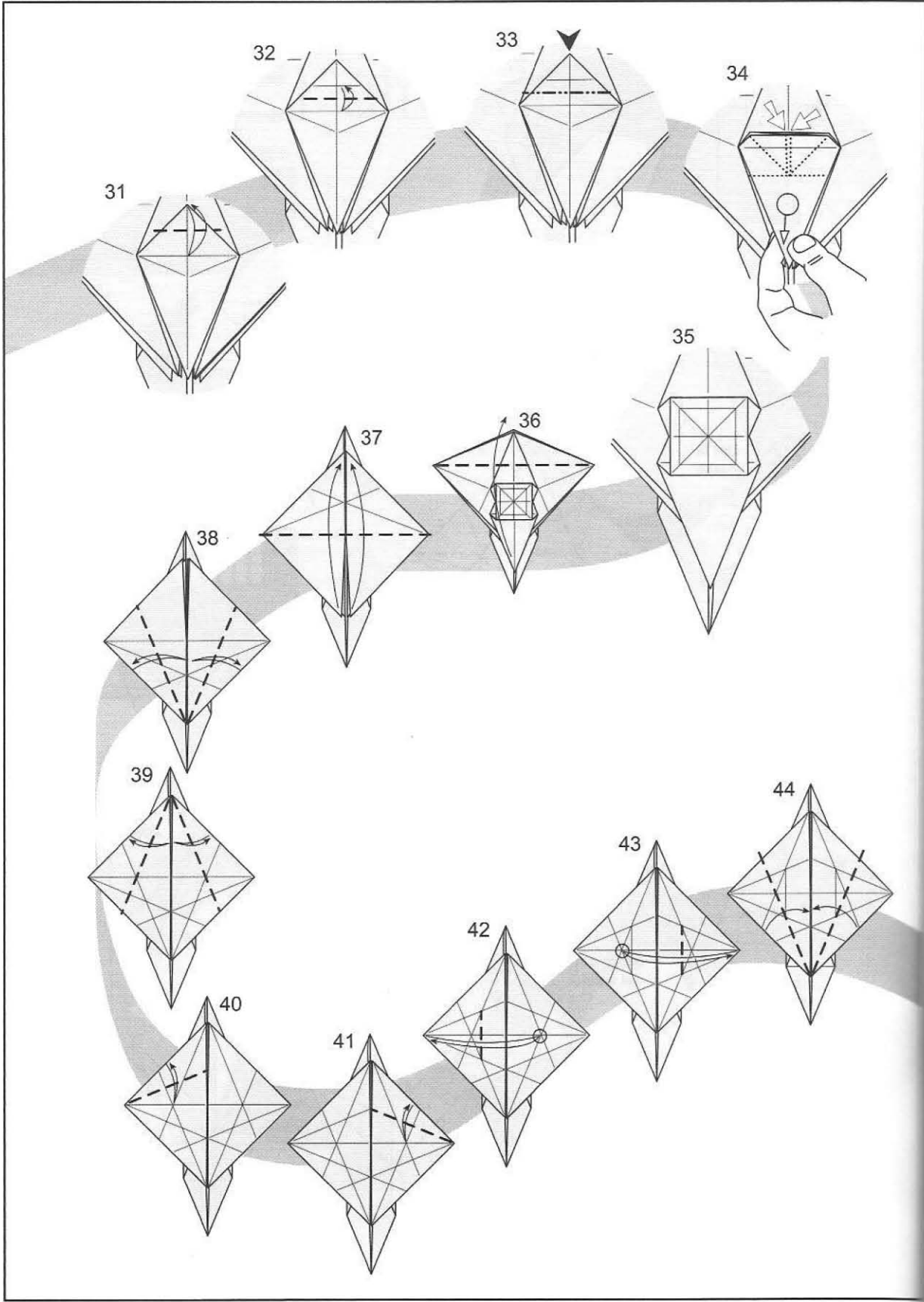

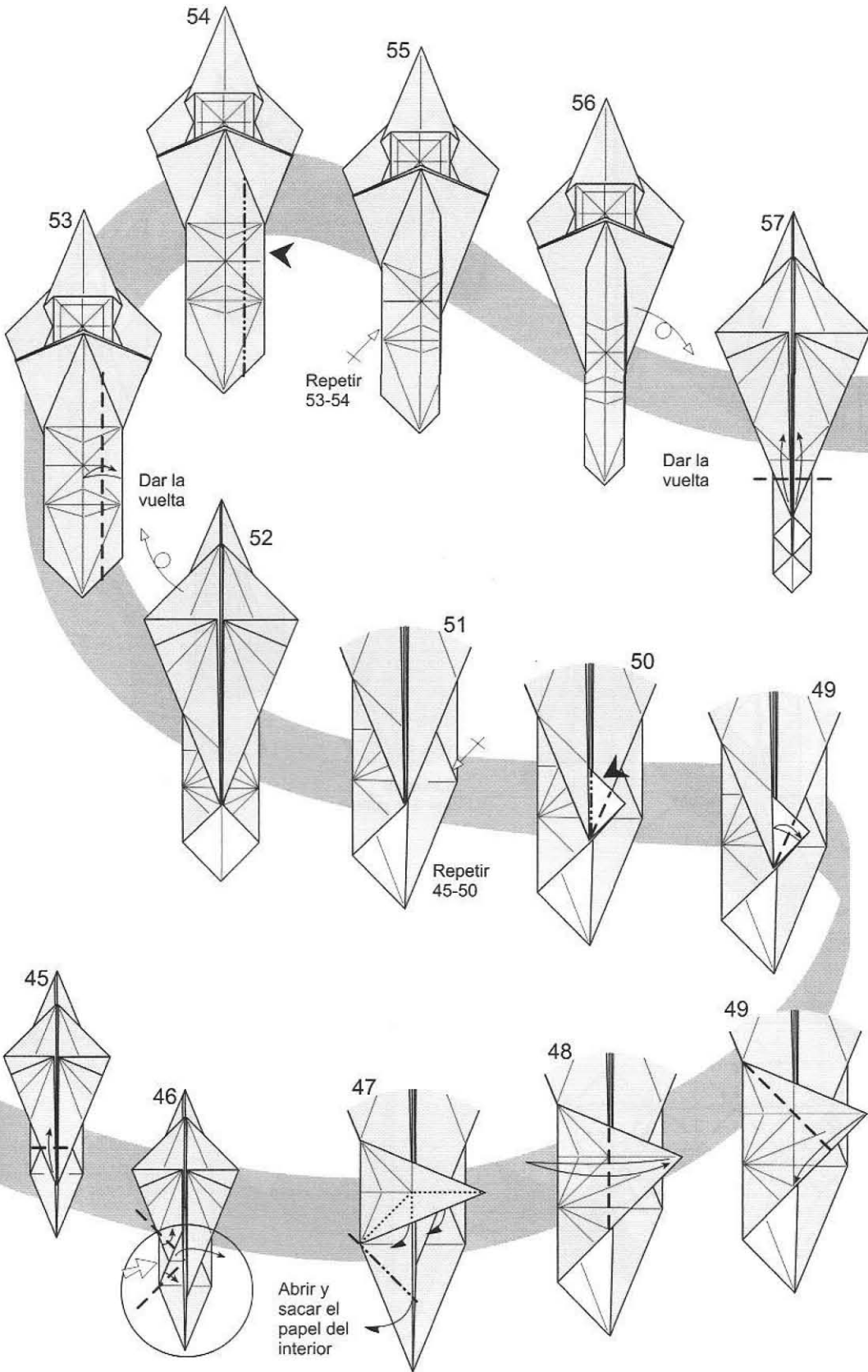

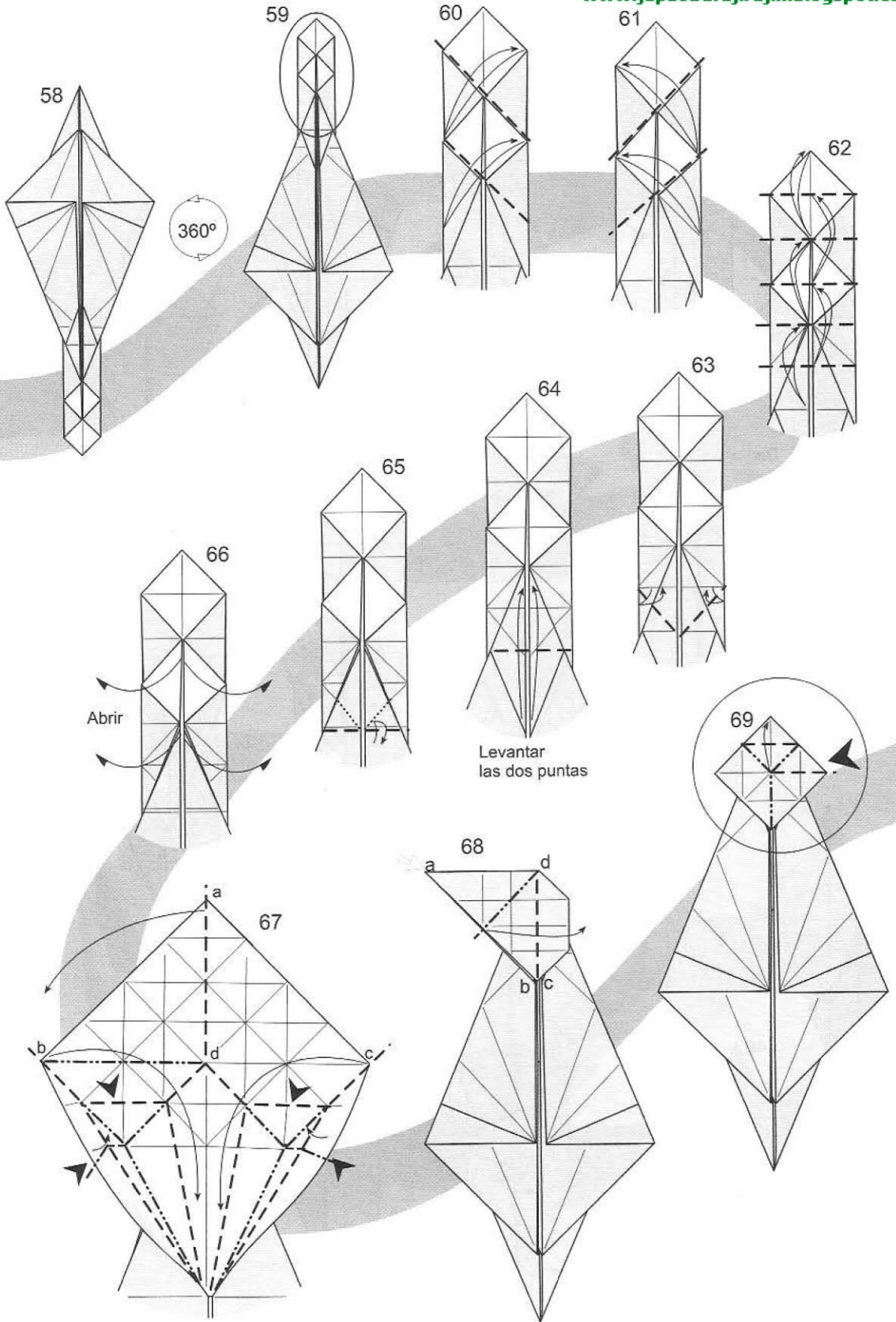

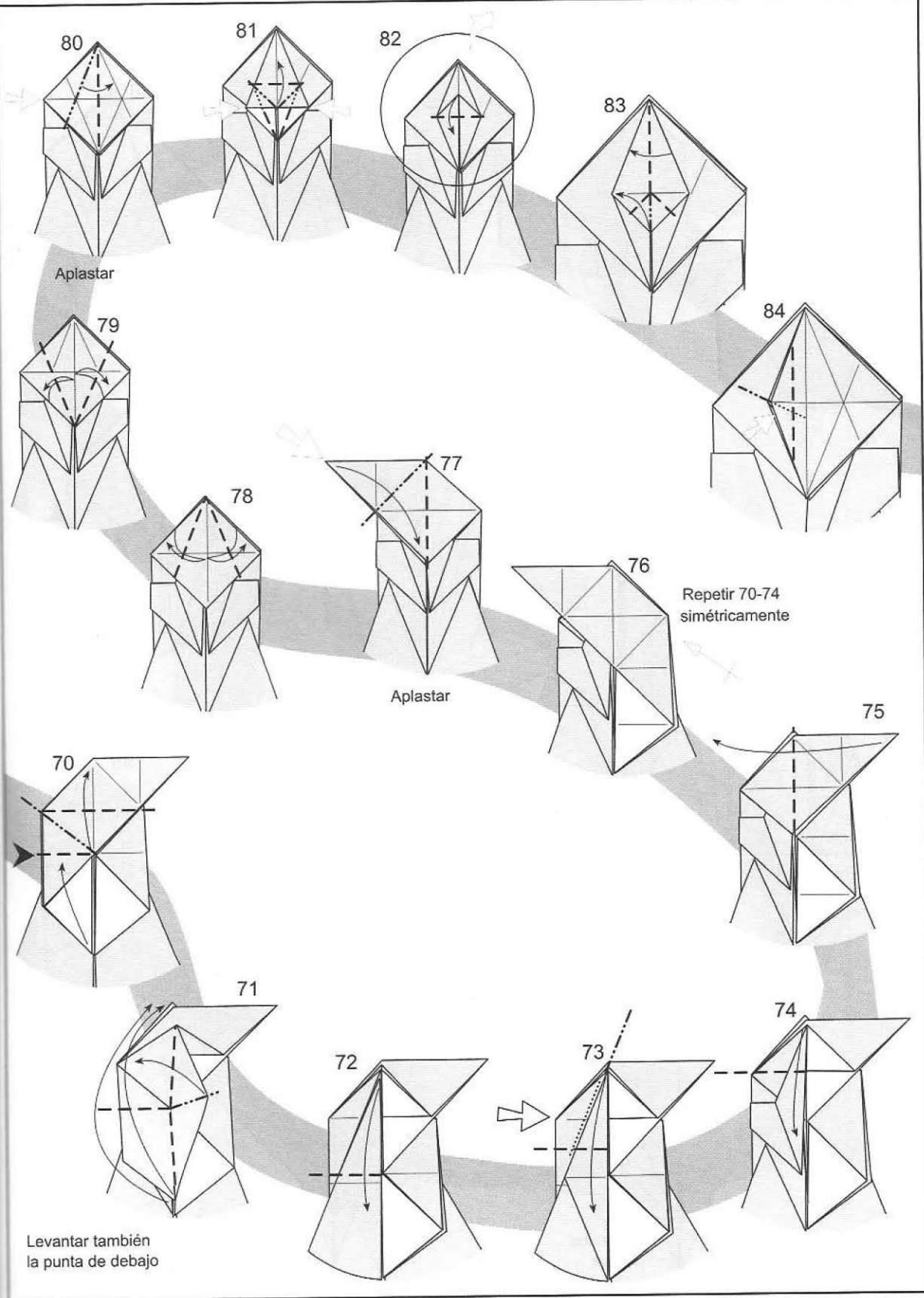

Levantar también la punta de debajo

Repetir 70-74 simétricamente

Aplastar

Aplastar

ウルティモ・ドラゴン/フェルナンド・ヒルガド (スペイン)

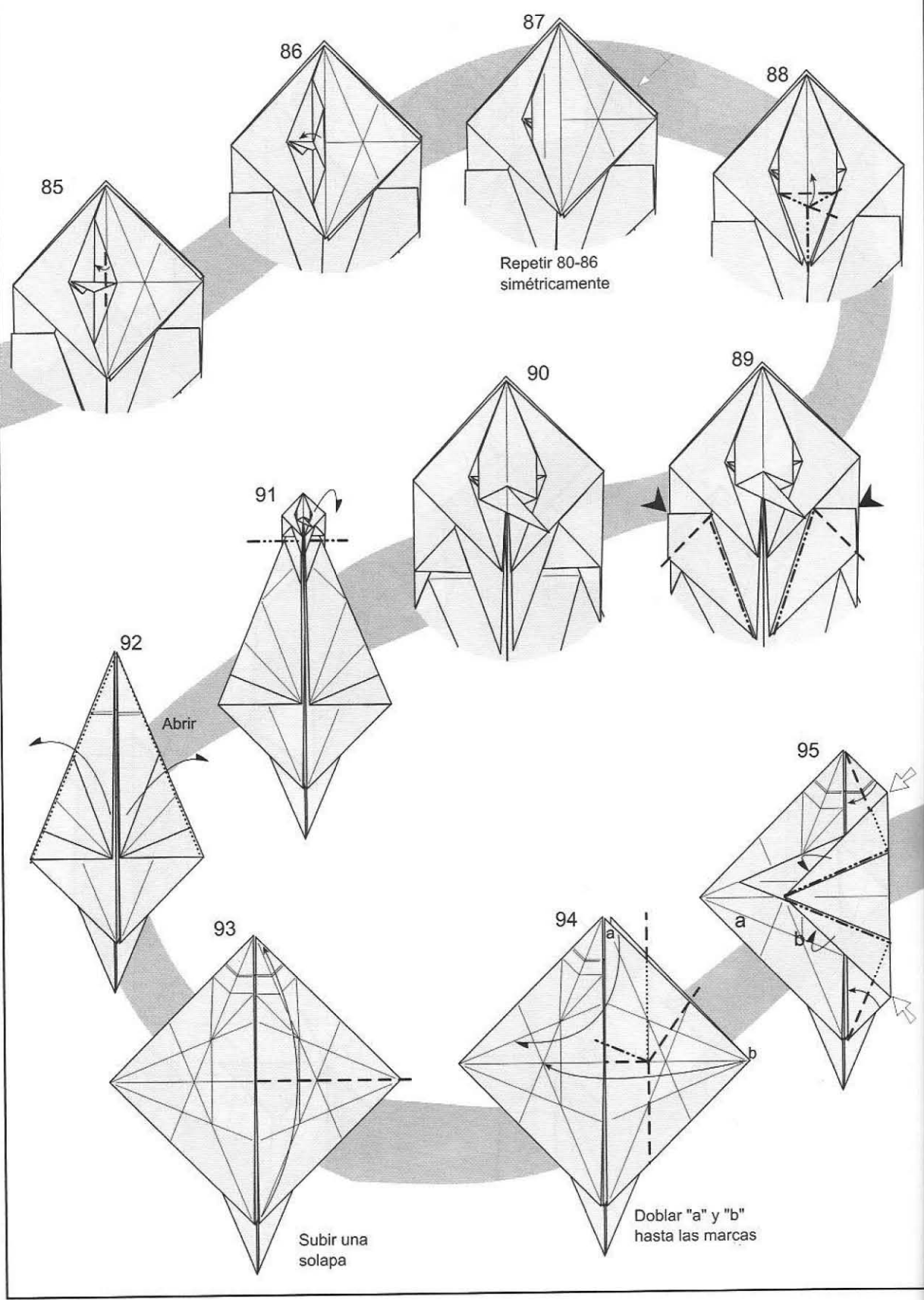

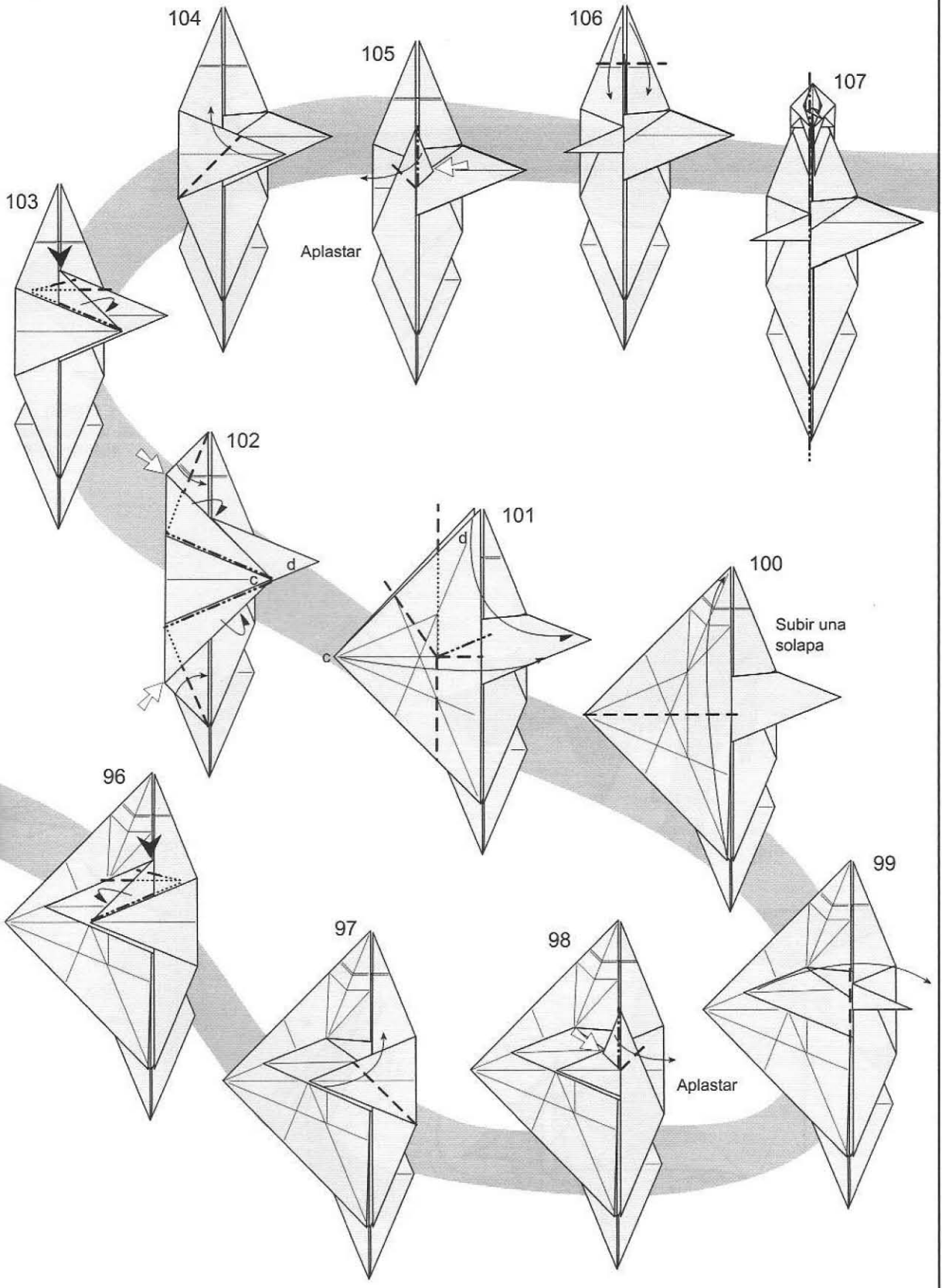

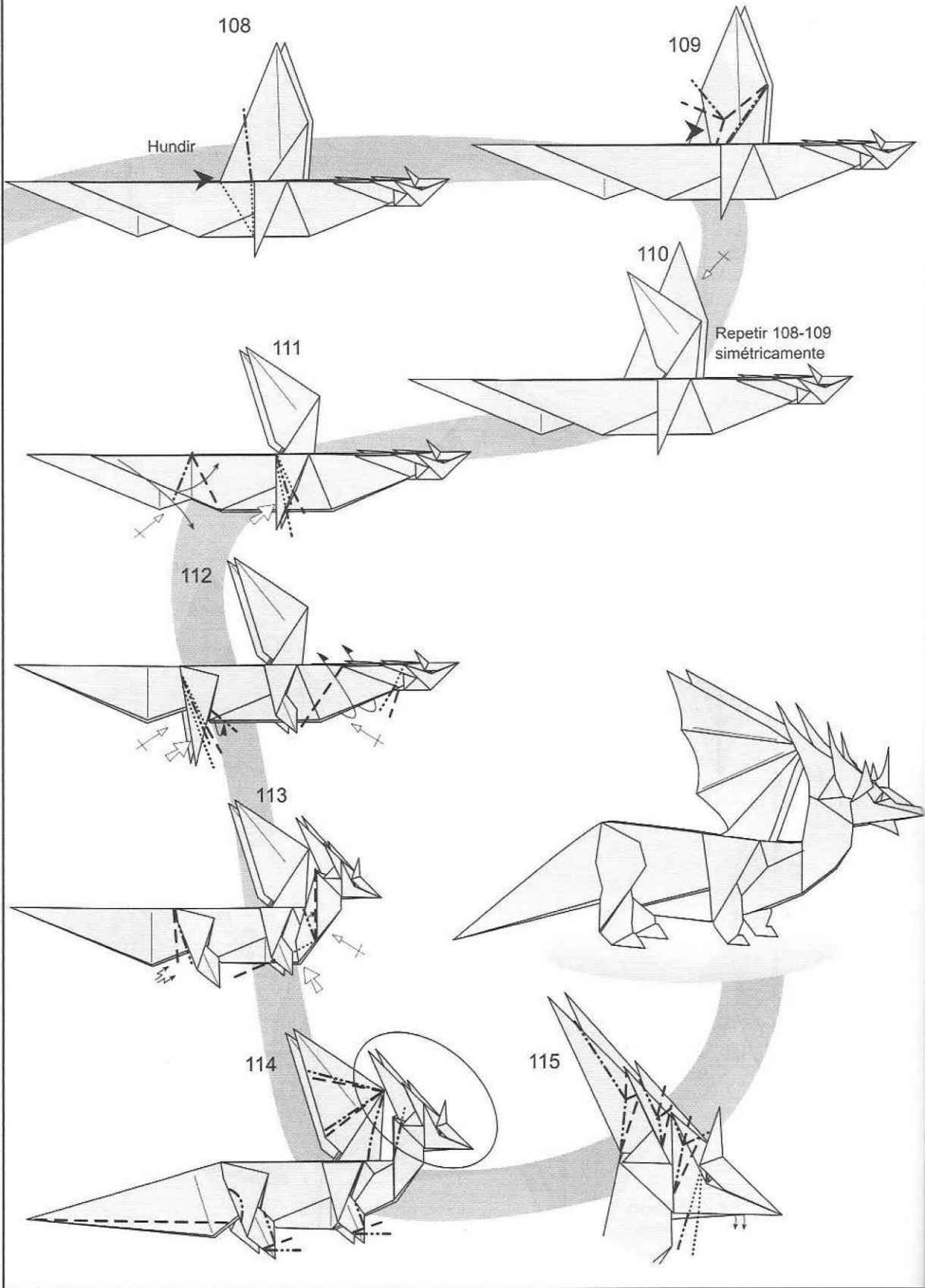

Lucanus Hembra

Nicolás Gajardo Henríquez

modelo: 23/01/2008
diagramas: 20/06/2008

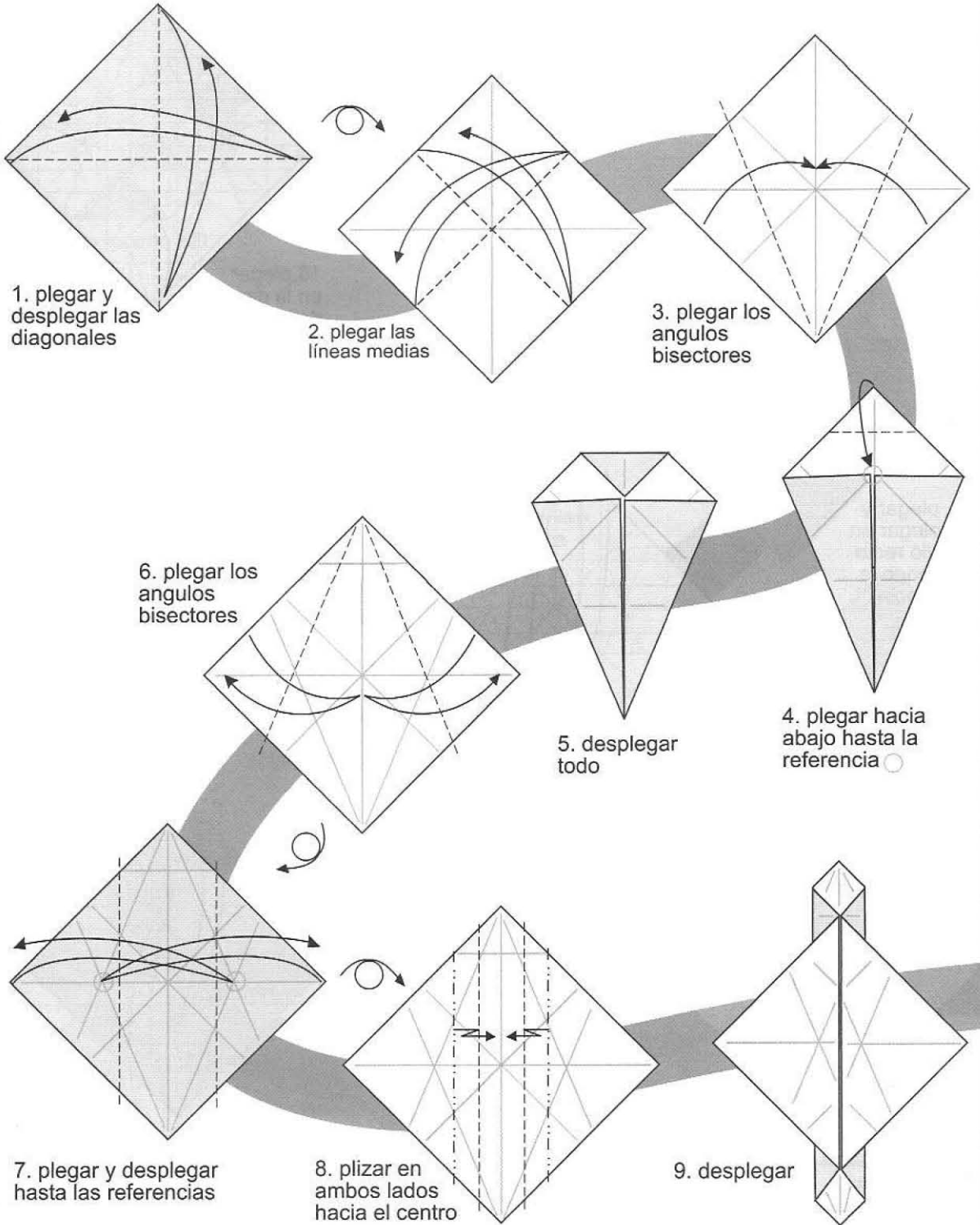

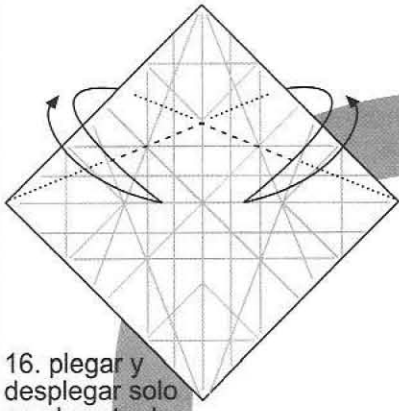

16. plegar y desplegar solo en el centro los angulos bisectores

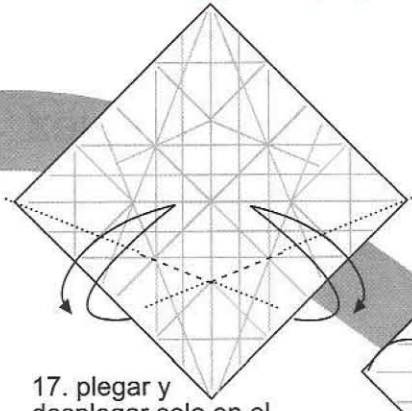

17. plegar y desplegar solo en el centro los angulos bisectores

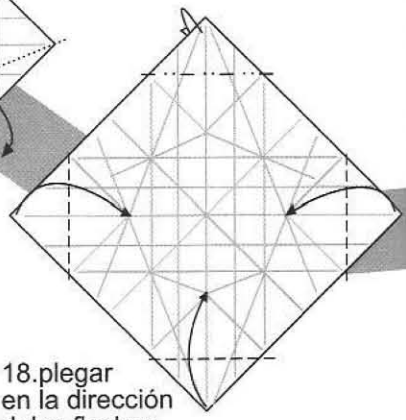

18. plegar en la dirección delas flechas

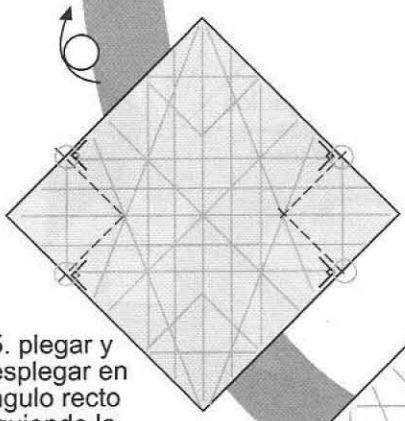

15. plegar y desplegar en angulo recto siguiendo la referencia ○

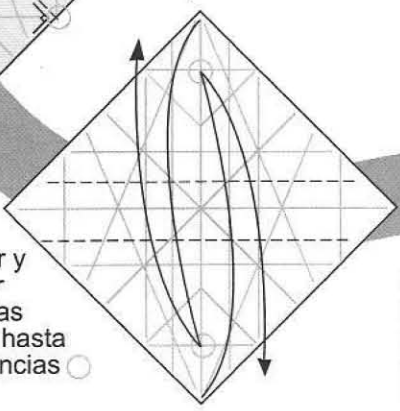

14. plegar y desplegar uniendo las esquinas hasta las referencias ○

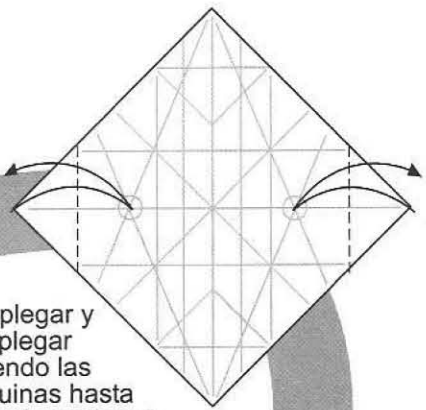

13. plegar y desplegar uniendo las esquinas hasta las referencias ○

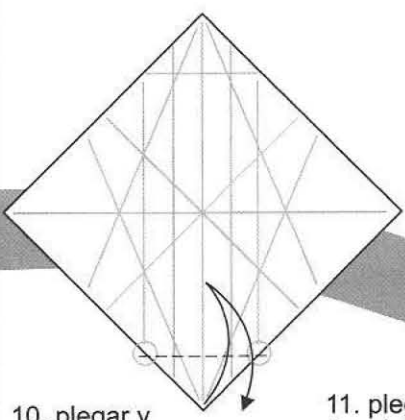

10. plegar y desplegar hacia arriba por las referencias ○

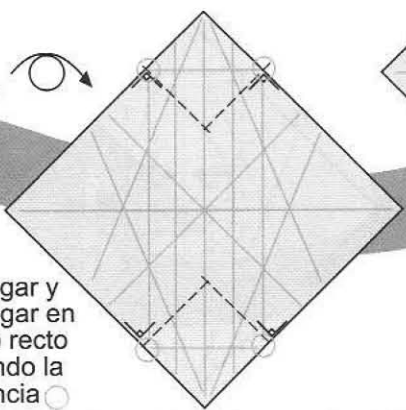

11. plegar y desplegar en angulo recto siguiendo la referencia ○

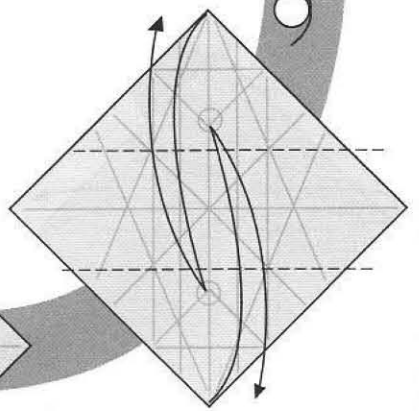

12. plegar y desplegar uniendo las esquinas hasta las referencias ○

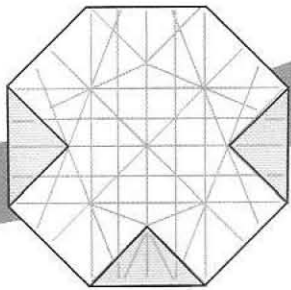

19. paso muerto XD

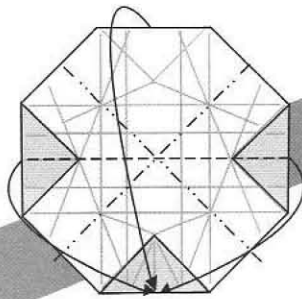

20. ensamblar por las líneas existentes

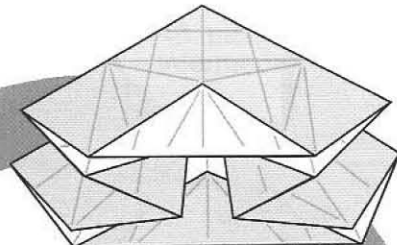

21. paso intermedio

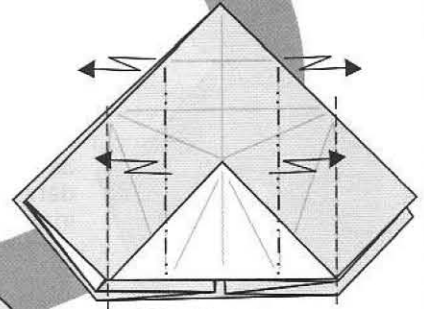

22. plizar en ambos lados

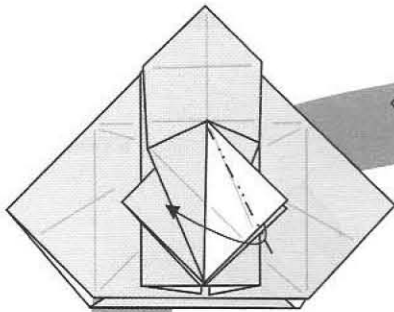

23. levantar la cuspide de la parte blanca

24. abrir y aplastar

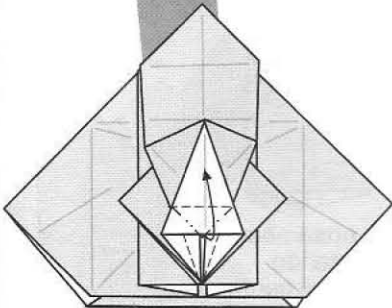

25. crear pétalo

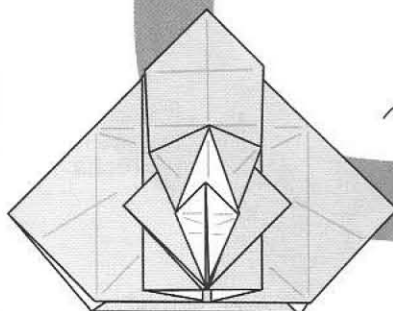

26. vista del paso 25, voltear

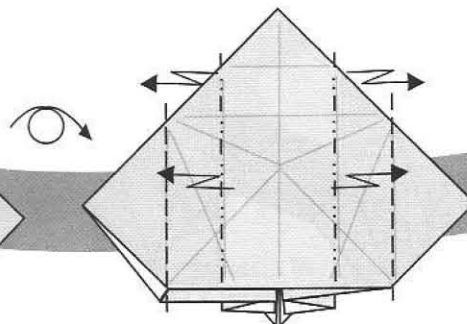

27. plizar en ambos lados

29. plegar hacia dentro

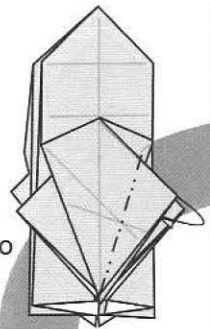

28. ensamblar levantando desde el centro

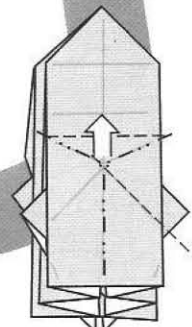

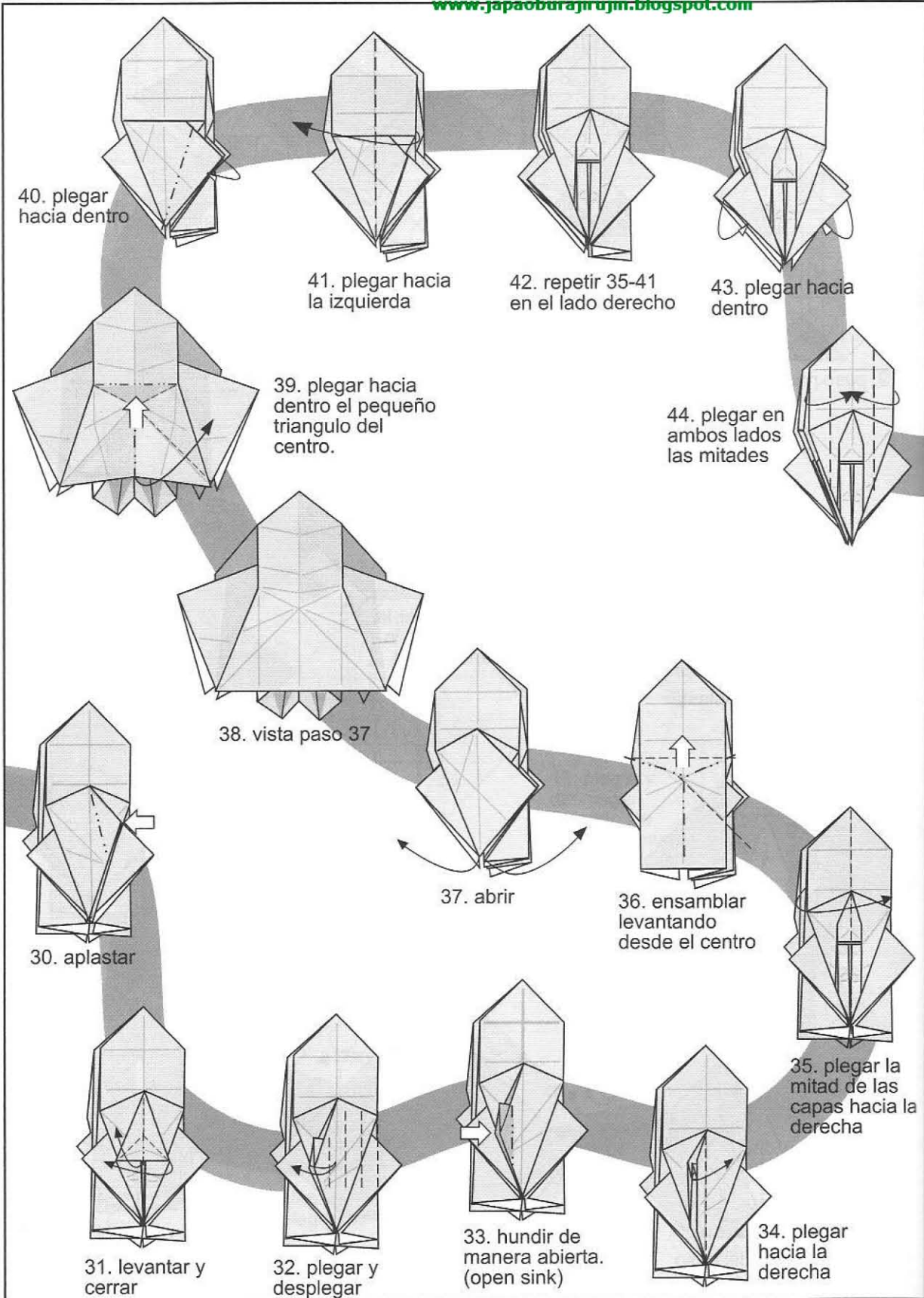

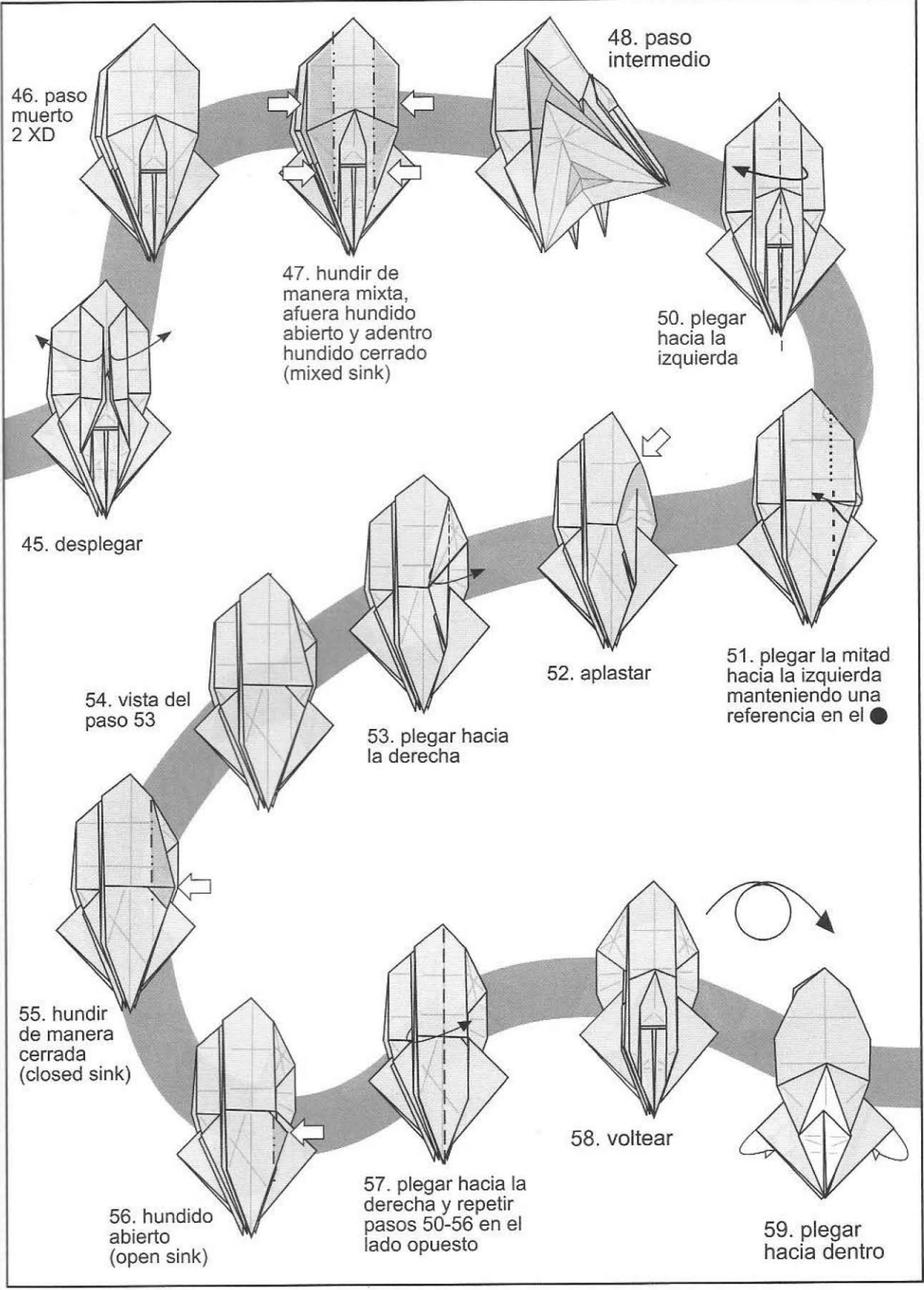

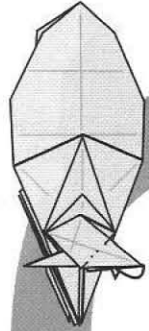

70. plegar hacia dentro

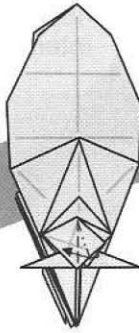

71. abrir y aplastar

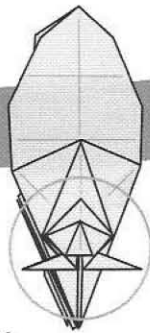

72. acercamieto (zoom)

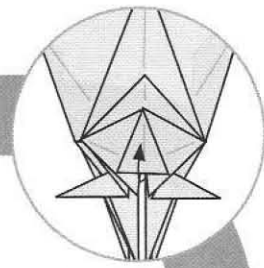

73. crear pétalo

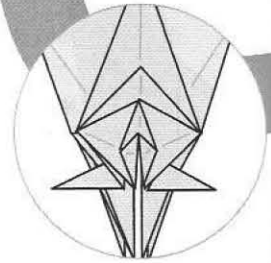

74. la punta del pétalo debe quedar dentro del modelo

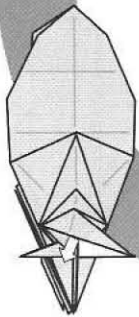

69. extraer el papel

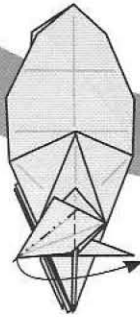

68. plegar hacia la derecha

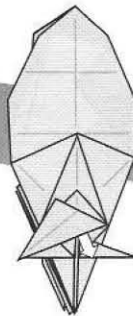

67. extraer el papel



66. plegar hacia abajo considerando la referencia y coincidiendo los lados

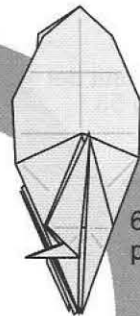

65. repetir pasos 62-64

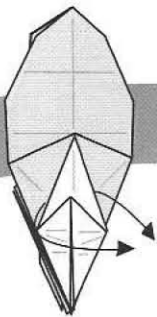

60. liberar capa en blanco

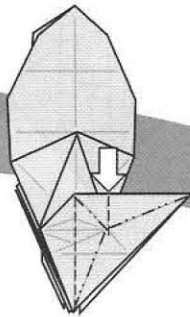

61. ensamblar por los pliegues existentes

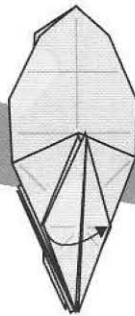

62. plegar hacia la derecha

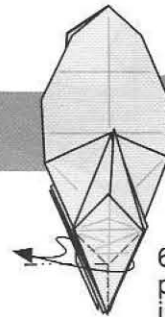

63. encrespar por donde se indica

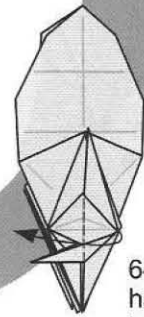

64. plegar hacia la izquierda

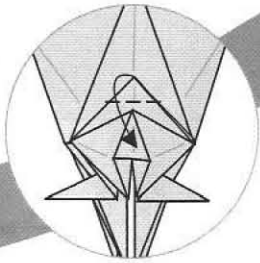

75. plegar hacia abajo a la mitad de la cuspide de la base pájaro

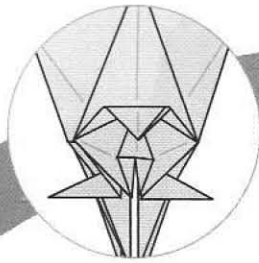

76. desplegar

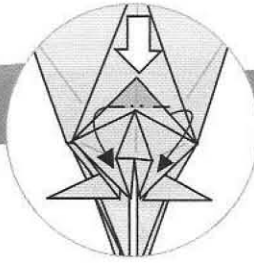

77. aplastar

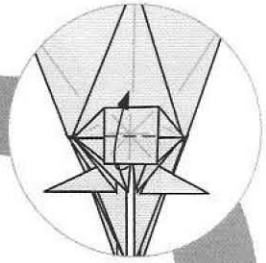

78. levantar

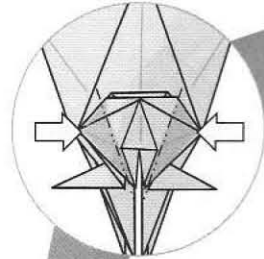

81. vista

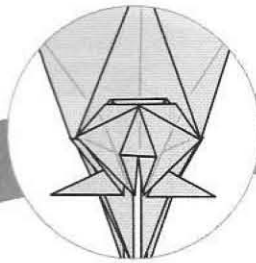

80. desplegar

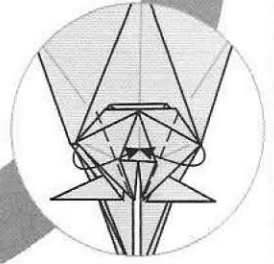

79. plegar los angulos bisectores

82. hundido mixto, arriba cerrado y abajo abierto. (mixed sink) (mixed sink)

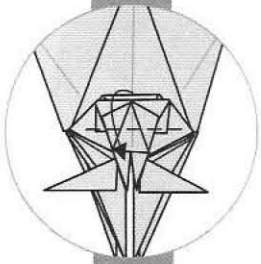

83. plegar hacia abajo

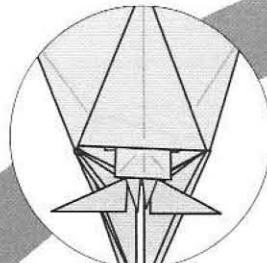

87. volver a la vista total

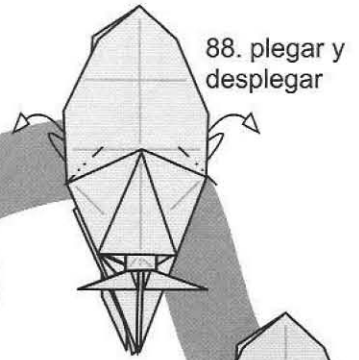

88. plegar y desplegar

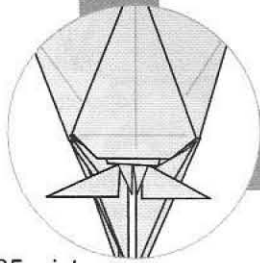

85. vista

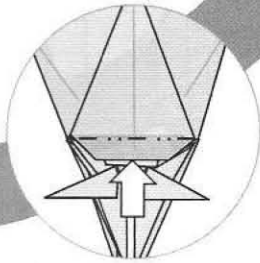

86. hundir cerrado (closed sink)

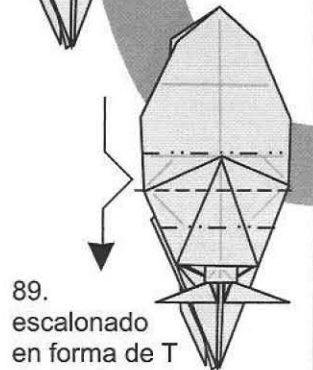

89. escalonado en forma de T

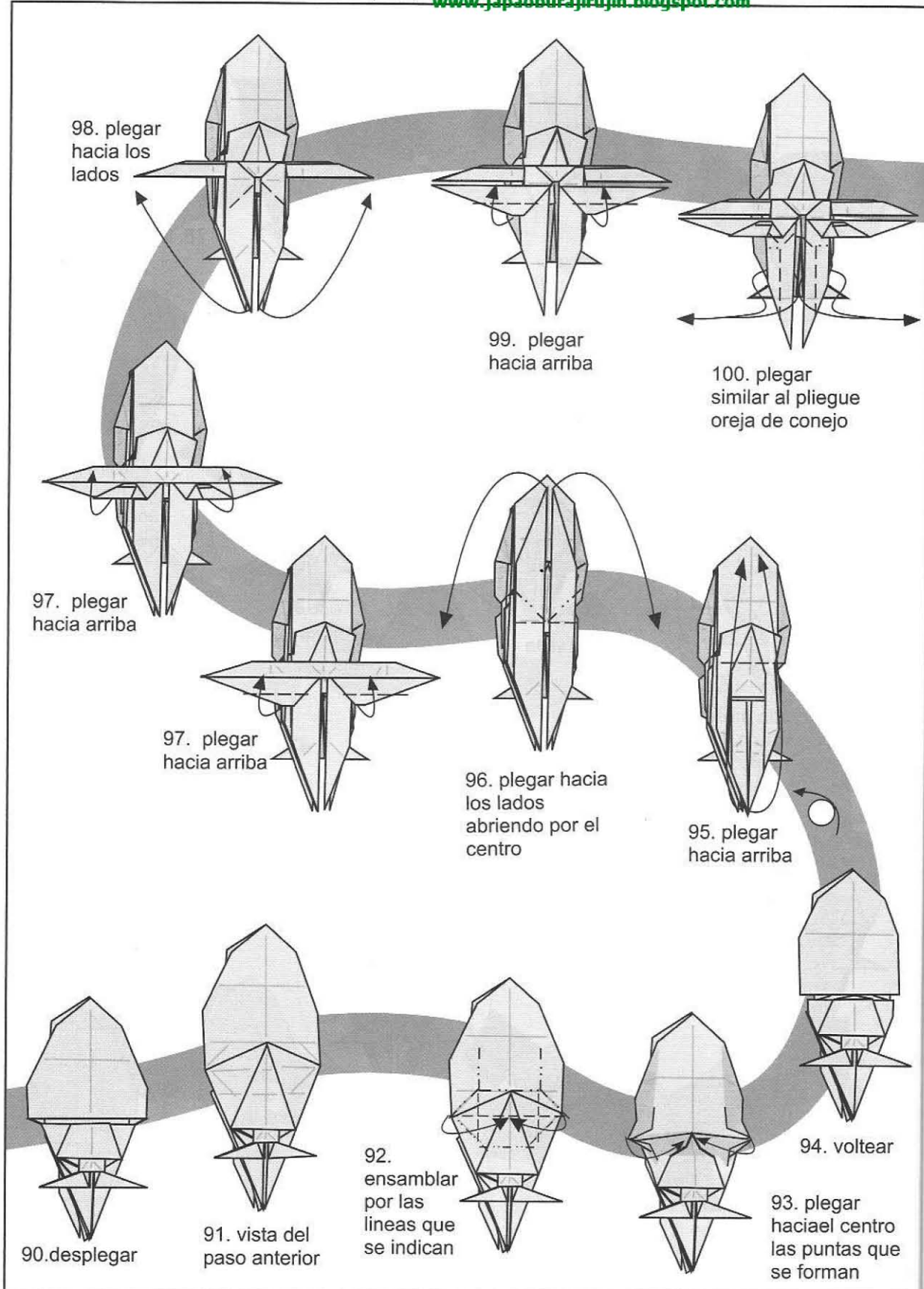

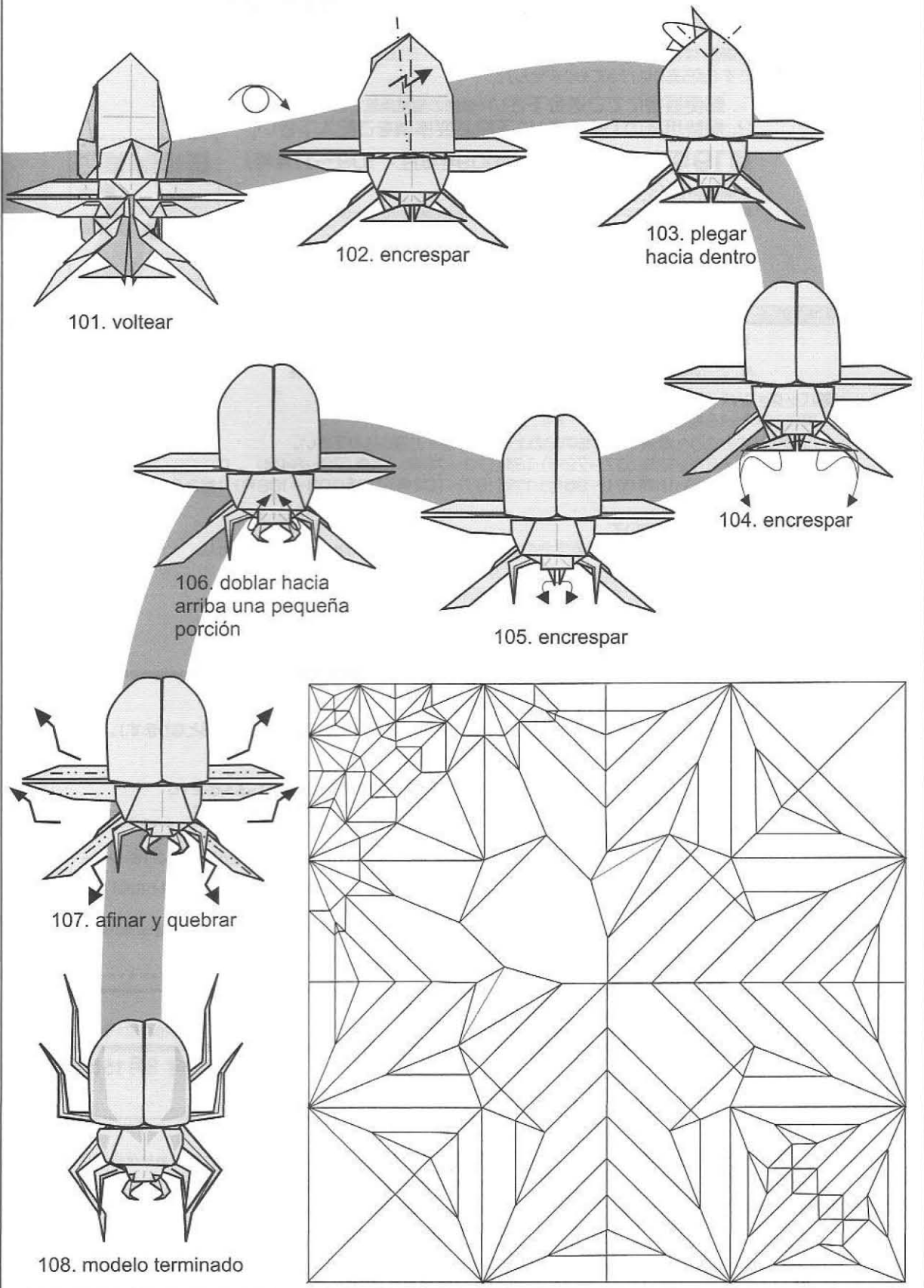

雑誌『折紙探偵団』年間購読のご案内

雑誌『折紙探偵団』は日本折紙学会の機関誌です。隔月刊(奇数月 25日発行)で年6回発行されます。年間購読制です(ばら売りは行っておりません)。

- 申込方法**
1. 郵便振替にてご送金下さい(普通の振替用紙でお申込み頂けます)。
 2. 振替用紙の「通信欄」に下記必要事項をご記入下さい。

第19期(2008年4月～2009年3月/109～114号)

年間購読費 **3,800円**(税、送料込み)

期変わりに料金に変更になる場合があります。2009年以降は事務局にお問い合わせください。

口座名 **日本折紙学会**

振替口座番号 **00170-7-260699**



雑誌『折紙探偵団』109号表紙
表紙フルカラー/本文38ページ
(カラー口絵2ページ含む)

記入必要事項 1～3は必ずお書き下さい。

1. 住所
2. 氏名 ※ふりがなをお願いします。
3. 電話、FAX番号
4. E-Mailアドレス
5. 性別
6. 生年月日
7. 職業

■バックナンバー購入について

現在11期～18期を取り扱っております。購入ご希望の場合は、

「通信欄」のところへ希望する期を明記の上、相当金額をお振り込み下さい。

11期(61～66号)・12期(67～72号)・13期(73～78号)・14期(79～84号)

15期(85～90号)・16期(91～96号)・17期(97～102号)・18期(103～108号)

(税、送料込み)
1期**3,800円**

■雑誌『折紙探偵団』について

・『折紙探偵団』は日本折紙学会の機関誌です。購読には学会会員である必要はありません。

・隔月刊(奇数月 25日発行)で年6回発行されます。

・年間購読のみ受け付けています。ばら売りは行っておりません。

・海外発送をご希望の場合は料金が異なります。事務局へお問い合わせください。

・折り図・展開図・折り紙研究・エッセイ・最新情報など充実の誌面です。

日本折紙学会 会員募集のお知らせ

日本折紙学会では、随時会員を募集しております。申込方法は定期購読と同じです。

会費には19期定期購読料も含まれています(すでに19期を購読されている方は4,600円となります)。

第19期会費 8,400円 ※通信欄に「第19期会費」と明記してください

日本折紙学会事務局(10:00～18:00 日祝休)〒113-0001 東京都文京区白山 1-33-8-216

Phone/Fax 03-5684-6080 日本折紙学会ホームページ <http://www.origami.gr.jp/>

ギャラリーおりがみはうすのご案内 〒113-0001 東京都文京区白山1-33-8-216

■1989年にオープンした、日本最初 営業日/月曜～金曜 12:00～14:00 (前日までに要予約。TEL:03-5684-6040)
の折り紙作品専門ギャラリー。公開時 /土曜 10:00～18:00 (土曜日の予約は必要ありません)
間は右記の通りです。 定休日/日曜・祭日 ※特別展等の際は平日も公開。詳細は下記HPにて随時ご案内致します。

ホームページ = <http://www.origamihouse.jp/> e-mail = info@origamihouse.jp

第14回 折紙探偵団コンベンション折り図集

PRINTED IN JAPAN

2008年 8月15日発行

著者/日本折紙学会

発行人/前川 淳

編集人/山口 真

編集スタッフ/松浦英子・神谷哲史

デザイン/おりがみはうす

発売元/おりがみはうす

発行所/日本折紙学会

113-0001

東京都文京区白山 1-33-8-216 (ギャラリーおりがみはうす内)

Phone & Fax 03-5684-6080 (10:00～18:00/日・祭日休)

E-mail = webman@origami.gr.jp

Web Site = <http://www.origami.gr.jp/>

■OrigamiTanteidan Convention Book vol.14 / Published on 15. August 2008 by Japan Origami Academic Society, 1-33-8-216 Haku-san Bunkyo-ku 113-0001 Tokyo JAPAN / Publisher: Maekawa Jun / Editor in Chief: Yamaguchi Makoto / Editorial Design: OrigamiHouse

ORIGAMI TANTEIDAN
折紙探偵団
MAGAZINE
14th CONVENTION 2008

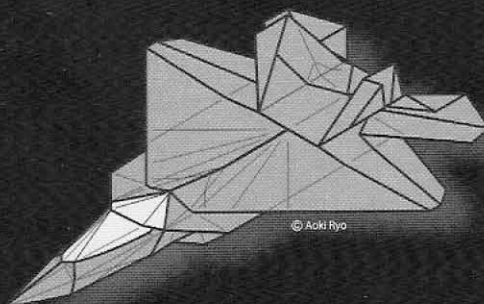
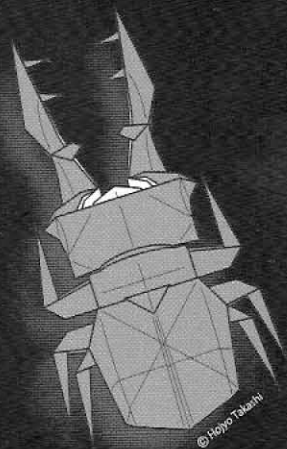

Japão Burajirujin
www.japaoburajirujin.blogspot.com

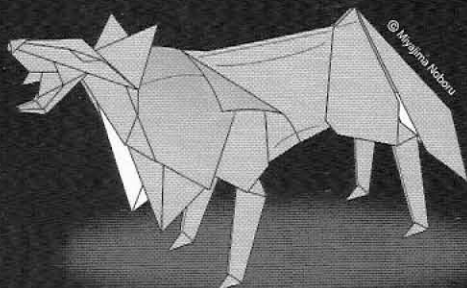
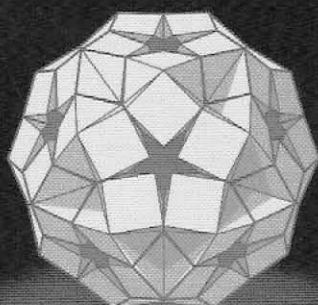

定価 2,000円