

ORIGAMI TANTEIDAN 9th CONVENTION

Japão Burajirujin

[www.japaoburajirujin.blogspot.com](http://www.japaoburajirujin.blogspot.com)

第9回

# 折紙探偵団 コンベンション

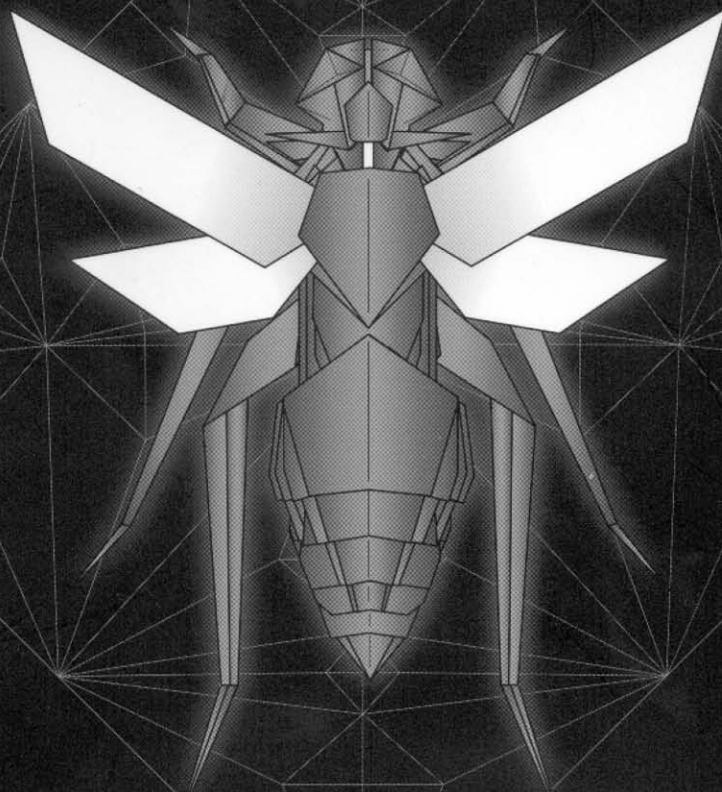

© Meguro Toshiyuki 2003

Japão Burajirujin

[www.japaoburajirujin.blogspot.com](http://www.japaoburajirujin.blogspot.com)

## 折り図集

### Vol.9

発行・日本折紙学会

ORIGAMI TANTEIDAN 9th CONVENTION

第9回  
折紙探偵団  
コンベンション

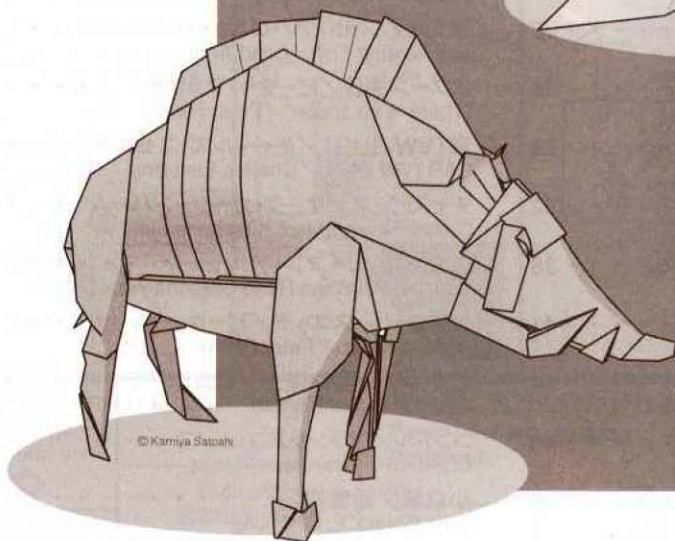
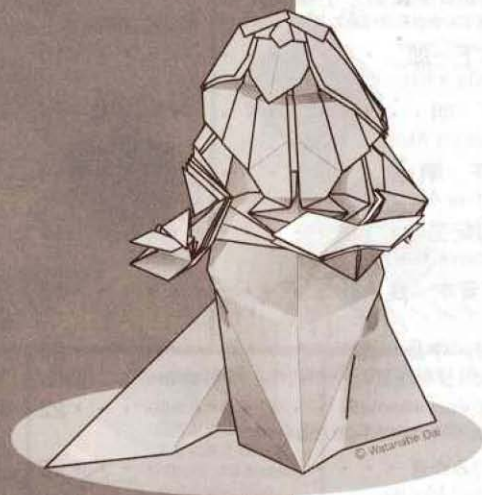
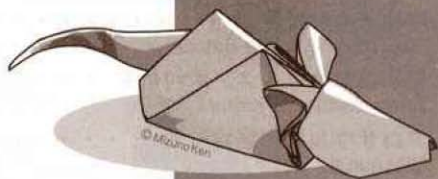

折り図集

Vol.9

## 9th Origami Tanteidan Convention Book

## CONTENTS

折り図記号	3
Symbols for Folding	
基本形・沈め折り	4
Preliminary Bases and Sink	

## 国内編：Models by Japanese Folders

一枚折り手裏剣の研究／笹出晋司	6
One sheet throwing knife "shuriken" / Sasade Shinji	
表裏同等一枚折り手裏剣／小松英夫他	8
One sheet inside-out isomorphic throwing knife "shuriken" / Komatsu Hideo, et. al.	
デジタル／木下一郎	10
Digital / Kinoshita Ichiro	
銀河／山下明	12
Galaxy / Yamashita Akira	
アデュー／山下明	13
Adieu / Yamashita Akira	
モーヴェ／黒川紀男	14
Moewe / Kurokawa Toshio	
スターシップ／青木良	18
StarShip / Aoki Ryo	
2枚組み花飾り／中島進	20
Flower Ornament (2pieces) / Nakajima Susumu	
桜／田中稔憲	22
Cherry Blossom / Tanaka Toshinori	
ホイップ／川村みゆき	25
Whip / Kawamura Miyuki	
ウェッジ／川村みゆき	26
Wedge / Kawamura Miyuki	
クリスタル・スプラッシュ／川村みゆき	29
Crystal Splash / Kawamura Miyuki	
1/3のおび／山田勝久	32
1/3 Strap / Yamada Katsuhisa	
7角形の畳紙／霞誠志	36
Heptagonal Tato / Kasumi Seishi	
リス／中川幸治	41
Squirrel / Nakagawa Kouji	
ねずみ／水野健	44
Mouse / Mizuno Ken	
犬(マック)／前川淳	46
Doggie whose name is Mac / Maekawa Jun	
クマ／西川誠司	48
Bear / Nishikawa Seiji	
日本猿／前川淳	54
Japanese macaque / Maekawa Jun	
オランウータン／磯村浩	55
Orangutan / Isomura Hiroshi	
スプリングボック／本田弦	58
Springbuck / Honda Gen	
ペリカン／芦村俊一	67
Pelican / Ashimura Shun'ichi	
アフリカツメガエル／北條高史	72
Xenopus borealis / Hojo Takashi	

マンタ／川畑文昭	74
Manta ray / Kawahata Fumiaki	
ラッコ／宮島登	80
Sea Otter / Miyajima Noboru	
鳳凰／山口智之	87
Phoenix / Yamaguchi Tomoyuki	
ケルベロス／福山研太郎	94
Cerberus / Fukuyama Kentarou	
北風の生まれ変わり／宮本真太郎	99
THE NORTH WIND / Miyamoto Shintaro	
黄色い鳥／神谷哲史	106
The Yellow Bird / Kamiya Satoshi	
猪神／神谷哲史	112
Boar God / Kamiya Satoshi	
ティラノサウルス／木村哲夫	125
Tyrannosaurus / Kimura Tetsuo	
アロサウルス／高井弘明	129
Allosaurus / Takai Hiroaki	
アシナガバチ／目黒俊幸	137
Long Legged Wasp / Meguro Toshiyuki	
掌の中の小鳥／渡辺大	159
A Bird on Hand / Watanabe Dai	

## 海外編：Models by Foreign Folders

孔雀のポップアップカード／ジェレミー・シェーファー	170
Peacock Pop-up Card / Jeremy Shafer	
歌う魚／ジラド・アハロニ	174
The Singing Fish / Gilad Aharoni	
スプーン曲げ／ピーター・ファリナ	176
"There is no spoon" / Peter Farina	
車(VW-BUG)／チャールズ・エセルティーン	178
CAR (VW BUG) / Charles Esseltine	
チェスピース／マーク・カーシェンバウム	183
Chess Pieces / Marc Kirschenbaum	
人魚／ウィリーマン・アルゼート	197
Sirena / Willyman Reed Cardona Alzate	
ゴールデン・スニッチ／ピーター・ファリナ	203
Golden Snitch / Peter Farina	
杖を持つ幽霊修道士／ニコラス・テリー	206
Ghost Monk with a stick / Nicolas TERRY	
コンドル／フランシスコ・ムノス	210
CONDOR / Francisco Munoz	
小白鷺／鍾富祥	213
Little Egret / F. C. Chung	
カミキリムシ／マヌエル・シルゴ・アルバレス	218
Acantocino / Manuel Sirgo Alvarez	
蜂／マヌエル・シルゴ・アルバレス	224
Escolia / Manuel Sirgo Alvarez	
カメ／エラン・ライセロヴィッツ	233
Turtle / Eran Leiserowitz	
キリン／ロナルド・コウ	237
Giraffe / Ronald Koh	
ライオン／ロバート・J・ラング	247
Lion / Robert J. Lang	

# 折り図記号 Symbols for Folding

## 折り線の種類 Types of crease lines

### 谷折り線 Valley fold

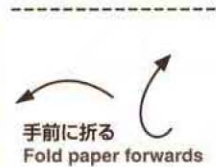

谷折り  
Valley fold



### 山折り線 Mountain fold



### 山折り Mountain fold



## 折り方の技法 Basic Folding Skills

### 中わり折り Inside-reverse fold

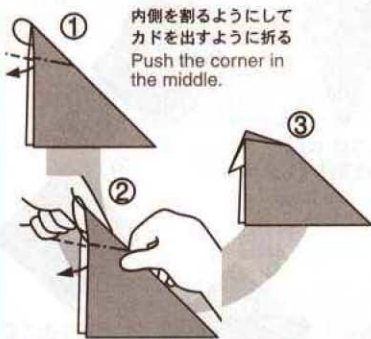

### かぶせ折り Outside-reverse fold

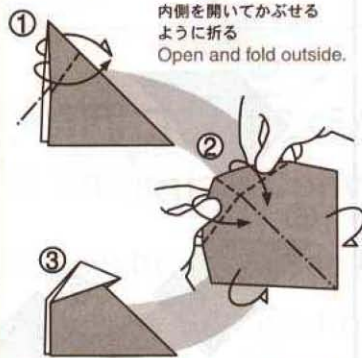

### 内側をひろげてつぶすように折る Squash fold

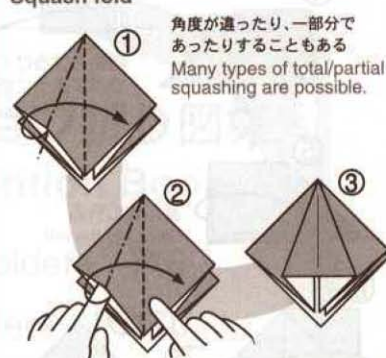

## いろいろな記号 Symbols

### 折り筋をつける Making a crease line

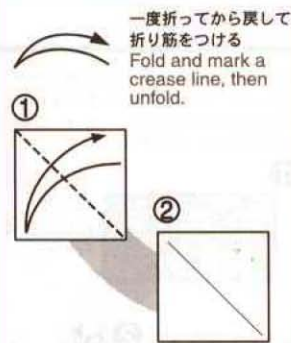

### 裏返す Turn paper over

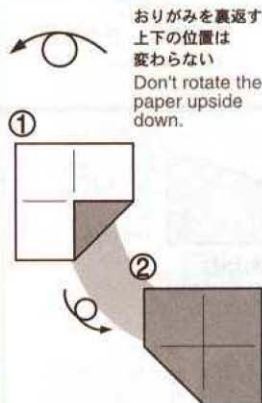

### 段折り Pleat fold

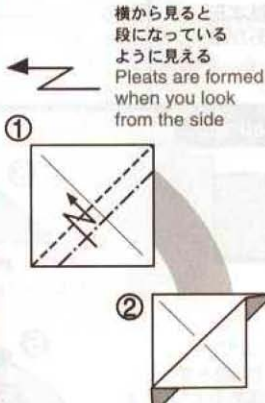

### 下の部分を出すように折る Release bottom flap when making a fold

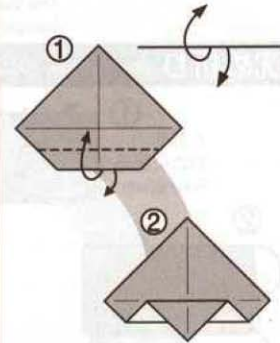

次の図が大きくなる  
A magnified view

ひろげる Open up

次の図の見える位置が変わる  
Paper position changes (rotation)

等分記号 Division

長さの等分 Dividing the length

数字で表す場合もある  
The ratio is often represented with numbers.

1/4 1/4 1/4 1/4

角度の等分 Dividing the angle

1つの図で2種類の等分を表す場合

Representing two types of division in one diagram

仮想線・透視線  
A hidden line

〇と〇を合わせて折る  
Match circled points

押す・つぶす  
Push paper in

巻くように折る  
Roll the flap by repeated folds

引き出す  
Pull out

注意するところ  
Marked points



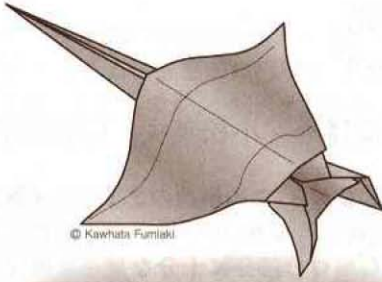

## 第9回折紙探偵団コンベンション折り図集 9th Origami Tanteidan Convention Book

国内編 / Models by Japanese Folders P.6

海外編 / Models by Foreign Folders P.170

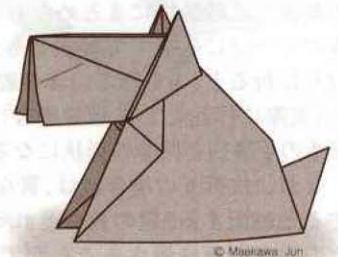
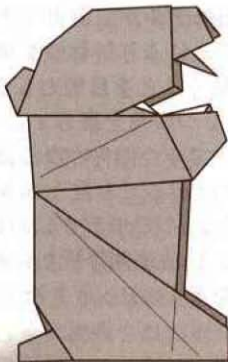
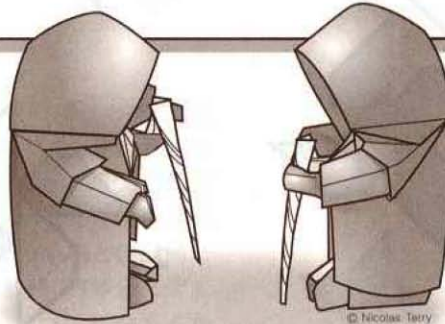

## 一枚折り手裏剣の研究 One sheet throwing knife "shuriken"

山田純 小笹径一 小松英夫 ○笹出晋司

### 1.はじめに

伝承の手裏剣は2枚の紙(2:1の長方形)を使用して折られるが1枚の紙を使用して同じ形を作る研究を行った。概要は下記のとおりである。

- 1)最終の仕上がり伝承2枚組と同じような動作で紙の層に差し込んで留める構造にした。
- 2)伝承と同じ大きさになる折り方を発見した。
- 3)4つの角、裏表が任意に色分けできる工夫をした。

### 2.山田モデル

2002年コンベンションで講習が行われたもので、本研究のきっかけになった元祖一枚折り手裏剣である。概念図を図.1に示す。

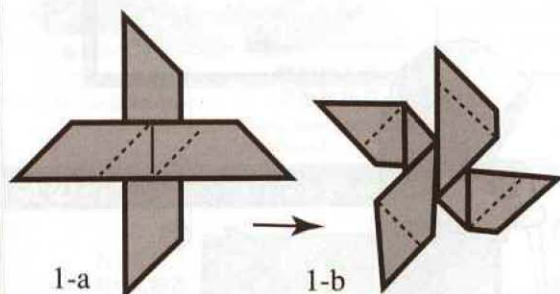

fig.1 山田モデル

1-aは正方形の各辺を5等分し、ボックスブリーツの要領で二艘船様にまとめたものである。これを2本のテープに見立てて裏表とも1-aに示す破線のとおり折ると1-bを得る。1-bの破線部分を取り去ると(実際に作品として折る場合は内部に折り込む)伝承の手裏剣と同等の形状になることがわかる。

なお、2枚折りの場合には、異なった色の紙を用意すると対面する2組の角がそれぞれ同色になった2色の手裏剣を作成することができ、また、これが一般的であるが、山田モデルにおいても色を変えたい角の部分の紙をひっくり返して裏面を出すことにより実現することができる。

しかしながら、この構造のまま2色手裏剣を作成すると、紙の重なり、引っ掛かりの制約から内部に差し込むペロの部分に十分な長さを確保することができなかった。

### 3.笹出モデル初号機

2002年のコンベンションで山田の講習を受講していた笹出はしばらく後fig.2に示す構造を提案した。

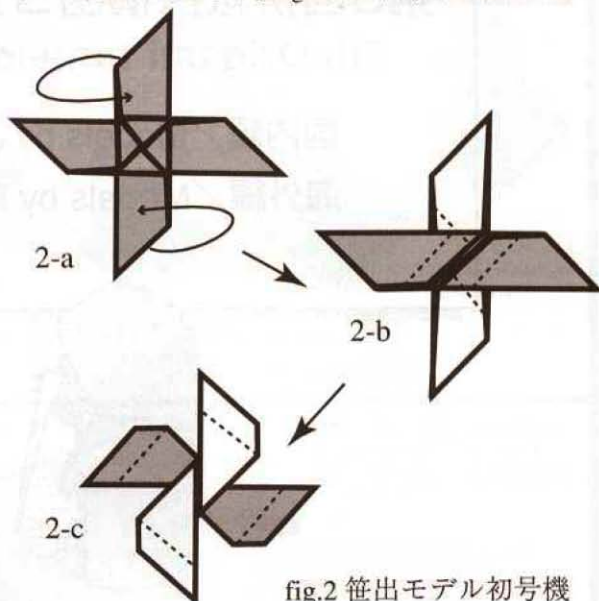

fig.2 笹出モデル初号機

このモデルは、山田モデルが二艘舟であったところを、風車様にしたことにより対称性を増させてペロが短くなることを防ぐことを目的とした。

2-aにおいて対面する2つの角を裏返すことで、2色を実現させたのち、2-bで4つの角となる部分をかぶせ折り(closedかぶせ折りとも言うべき折り方になる。)すると2-cを得る。このモデルにおいては、山折り谷折りを工夫すると、表裏同等折りも実現できた。

ただし、紙に無駄が多く、すっきり折ることが難しい。

## 第9回折紙探偵団コンベンション予稿集

## 4.小笹モデル

笹出モデル初号機の無駄を排除すれば4等分で実現可能であろうことは直感的に理解できるが、これを最初に実現させたものが、小笹モデルである。

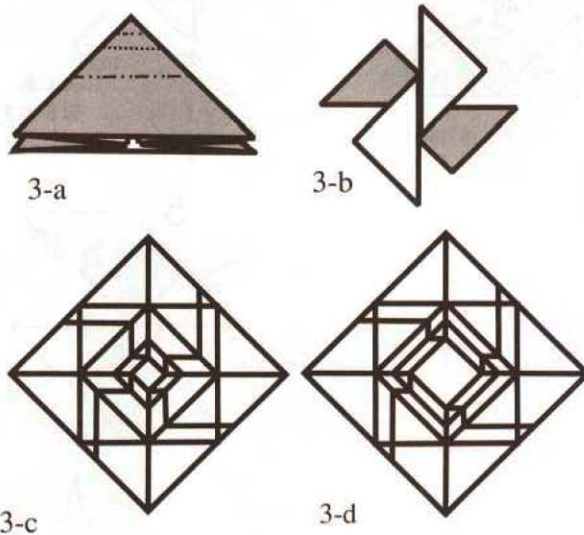

fig.3 小笹モデル

fig.3に示すとおり、風船の基本形の頂点の部分(紙の中心)から上下方向に2等分、4等分、8等分して段沈め折りしてできた二艘船のうち一艘を90度回転させてから風車様にするると2-aを太めにしたものを得ることができる。これを2-aから2-cの手順とほぼ同じように折ると、3-bを得る。これは前述の5等分モデルと比較したとき無駄が排除され、かつ折りやすくなっており優れたモデルと言える。参考に3-cに展開図を示す。また、3-dは笹出によるバリエーションである。(笹出モデル式号機)

これらモデルに関して特筆すべきことは、同じ大きさの正方形から作った伝承作の手裏剣と完成時の大きさが全く同じになることが挙げられる。

## 5.小松の単純化と笹出の色分け

小笹モデルにより完成したと思われた手裏剣プロジェクトであったが、小松により、中心部を表裏同等ねじり折りすると展開図がより単純化されることが指摘された。あまりに単純な展開図になったこと、また、季刊をる11号に掲載された前川淳氏の表裏同等風車などの類似性から、過去に作例がないであろうかということが話題になった。

(その後、2002年9月の例会で池上氏、神谷氏より、Jeremy Shafer氏の Promotional Brochure とほぼ同じ展開図であるとの情報をいただきました。しかしながら、100%同じではないこと、また、手裏剣になることは独自研究であり、単純なモデル故の偶然と考えます。)

また、笹出が前川氏のをる11号の記事を参考に色分けモデルを作った。fig.5に参考作例を示す。これらは同じ展開図の山折り谷折りを変えることで実現可能である。ここまで来ると完成形の表と裏で色分けを行いたくなってくるが、現在のところ6等分額縁折りを仕込んだ後、普通に折るという安易な方法に頼っている。しかし、裏も表も任意に色分けができるため、極めて自由度が高い方法ではある。

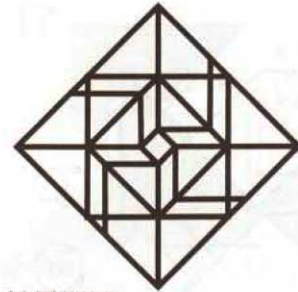

fig.4 小松展開図

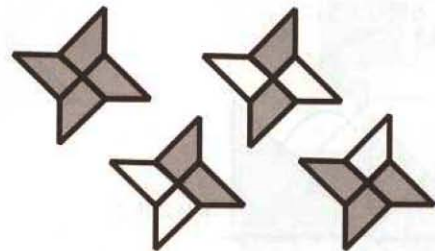

fig.5 色分けのバリエーション

## 6.おわりに

この研究は、2002年8月12日ころから8月22日ころまで共同研究者間で電子メールを活用して行なった。また、今回の研究成果を小松が折り図にまとめたのでそちらも参考とされたい。

最後に、御協力いただきました折紙探偵団に所属される探偵各位には、大変お世話になりましたことを深く感謝いたします。



One sheet inside-out isomorphic throwing knife "shuriken"

# 表裏同等一枚折り手裏剣

作 = 山田純 + 笹出晋司 + 小笹径一 + 小松英夫

Model designed by Yamada Jun, Sasade Shinji, Kozasa Keiichi, Komatsu Hideo Diagrams produced by Komatsu Hideo

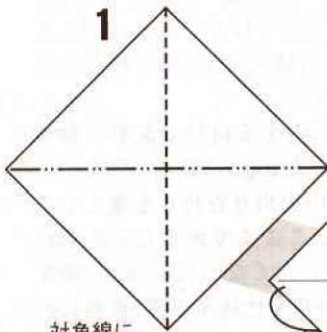

対角線に折り筋をつける

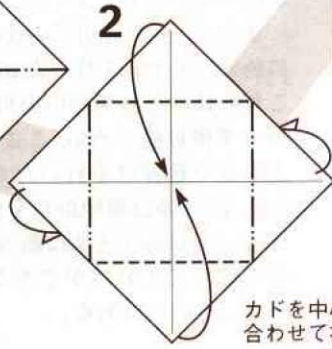

カドを中心に合わせて折る

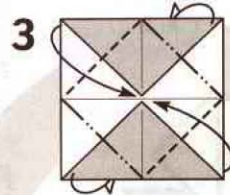

カドを中心に合わせて折る

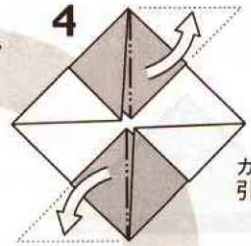

カドを引き出す

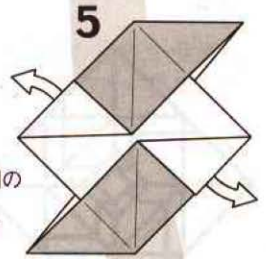

向こう側のカドも引き出す

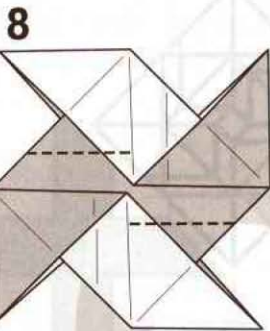

位置に気をつけて6~7と同じように折り筋をつける

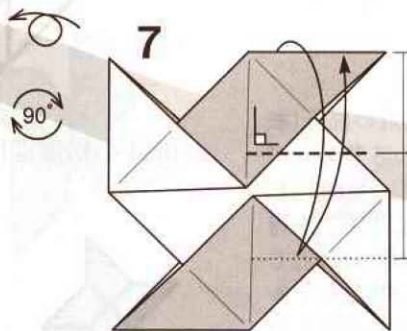

6と同じように折り筋をつける

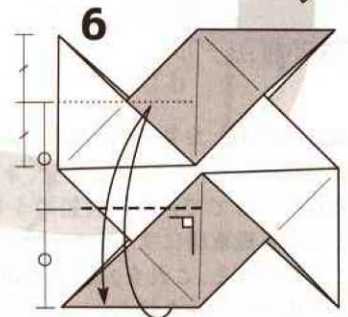

折り目が水平になるように注意して、図の目安でしっかりと折り筋をつける

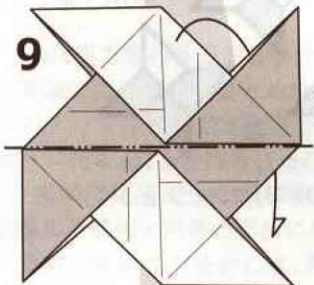

後ろに半分に折る

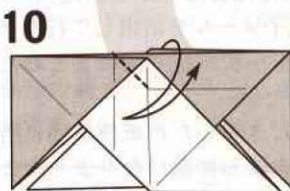

上の縁を垂直の折り筋に合わせて全ての層にしっかりと折り筋をつける

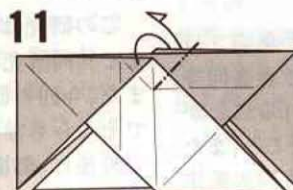

10と同じようにして折り筋をつける

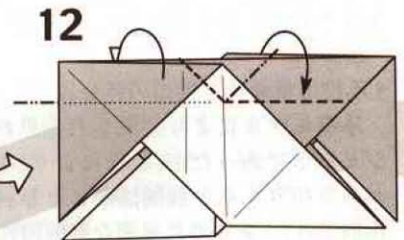

ついている折り目を使って上の縁が「Z」状になるように(ひねるように)折っていく

ORIGAMI TANTEIDAN 9th CONVENTION

**Japão Burajirujin**

[www.japaoburajirujin.blogspot.com](http://www.japaoburajirujin.blogspot.com)

第9回

# 折紙探偵団 コンベンション

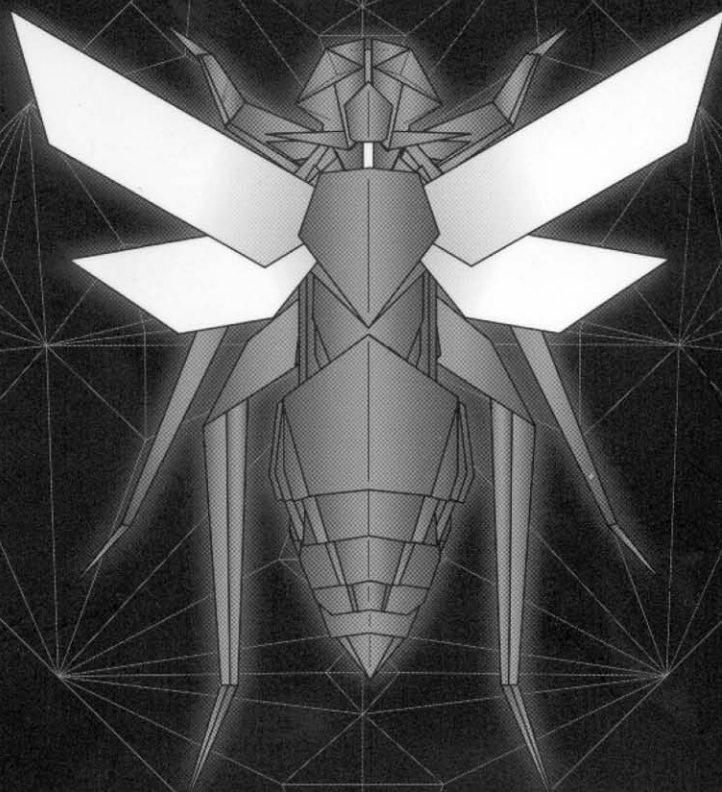

© Meguro Toshiyuki 2003

**Japão Burajirujin**

[www.japaoburajirujin.blogspot.com](http://www.japaoburajirujin.blogspot.com)

## 折り図集

### Vol.9

発行・日本折紙学会

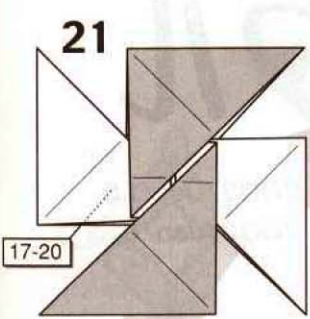

裏側も 17~20 と同じように折る  
(今度は白いカドを折る)

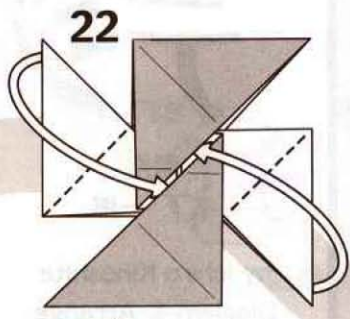

カドを折って  
すき間に差し込む

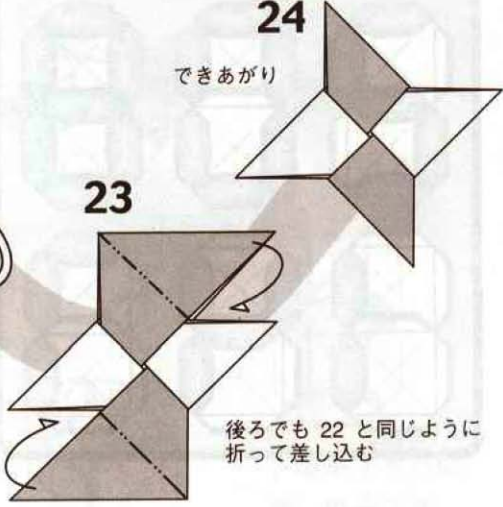

後ろでも 22 と同じように  
折って差し込む

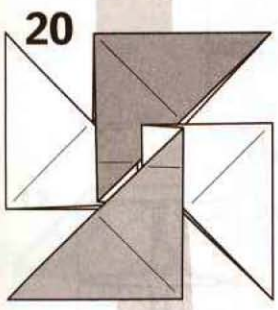

濃い色で示した紙を  
手前に持ってくる

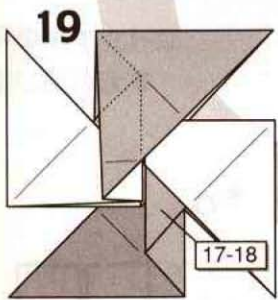

下のカドも 17~18 と  
同じように折る

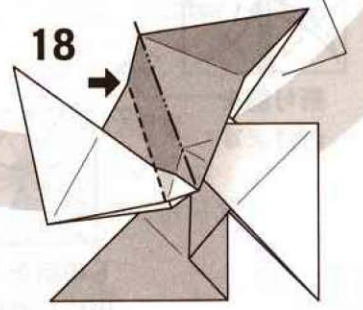

黒矢印のところを  
押し込んで  
平らにまとめなおす

上半分は半開きに  
なっている

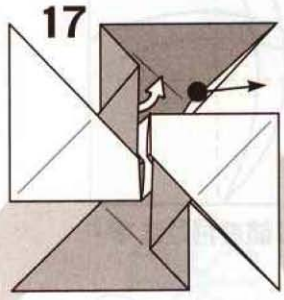

黒丸のところ  
(表の 1 枚のみ)  
を持って  
そっと引き出す

中心付近の  
折り込みが  
ほどけて分離する

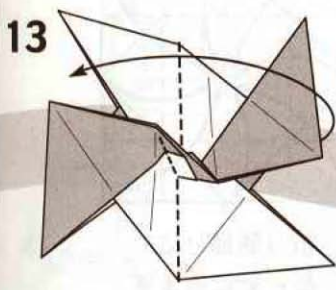
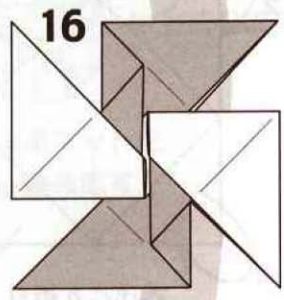

途中図  
平らに半分に折り畳む

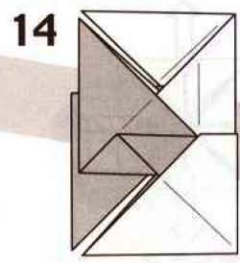

90°

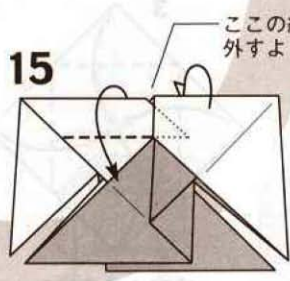

ここの紙の重なりを  
外すようにする

ついている折り目を使って  
上の縁を互い違いに折る

# デジタル

創作  
木下 一郎

2002/Dec/15  
2003/Jan/8

by Ichiro Kinoshita  
Diaglam & Arrange  
Eiji Tsuchito

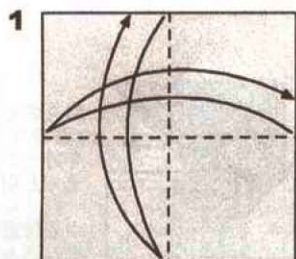
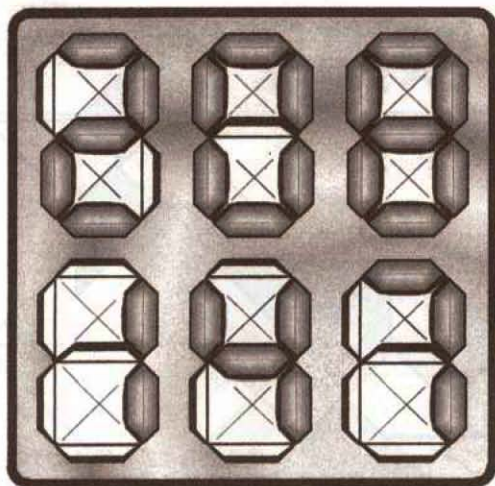

折り筋を付けます

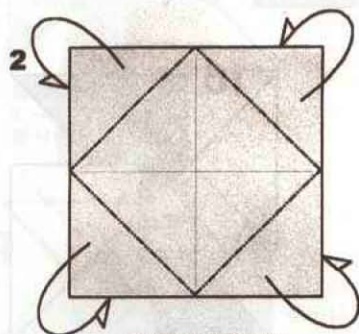

さぶとん折り

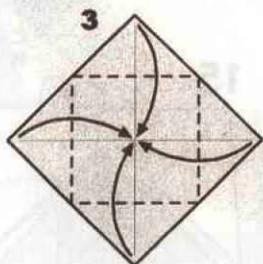

さぶとん折り

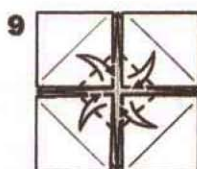

折り筋を付けます



折り筋を  
付けます

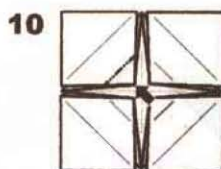

沈め折り

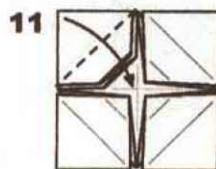

11

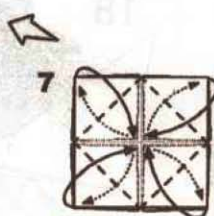

下の筋を上に出しながら折ります  
(はね折り)

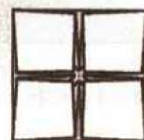

6

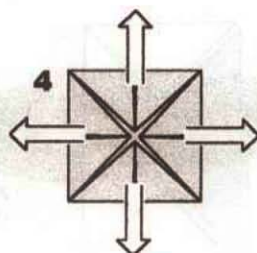

開きます

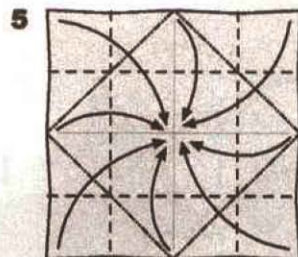

折り筋通りに  
折りたたみます

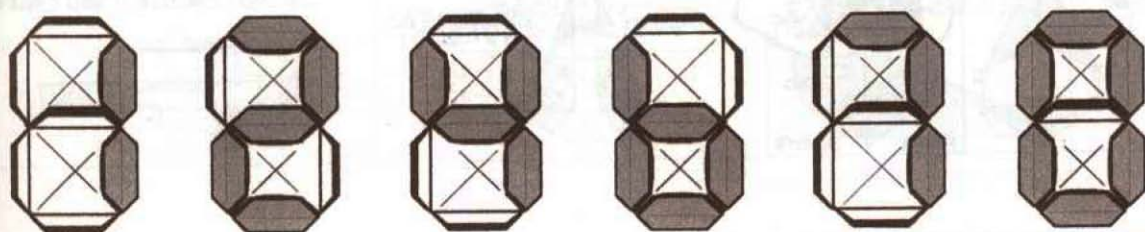
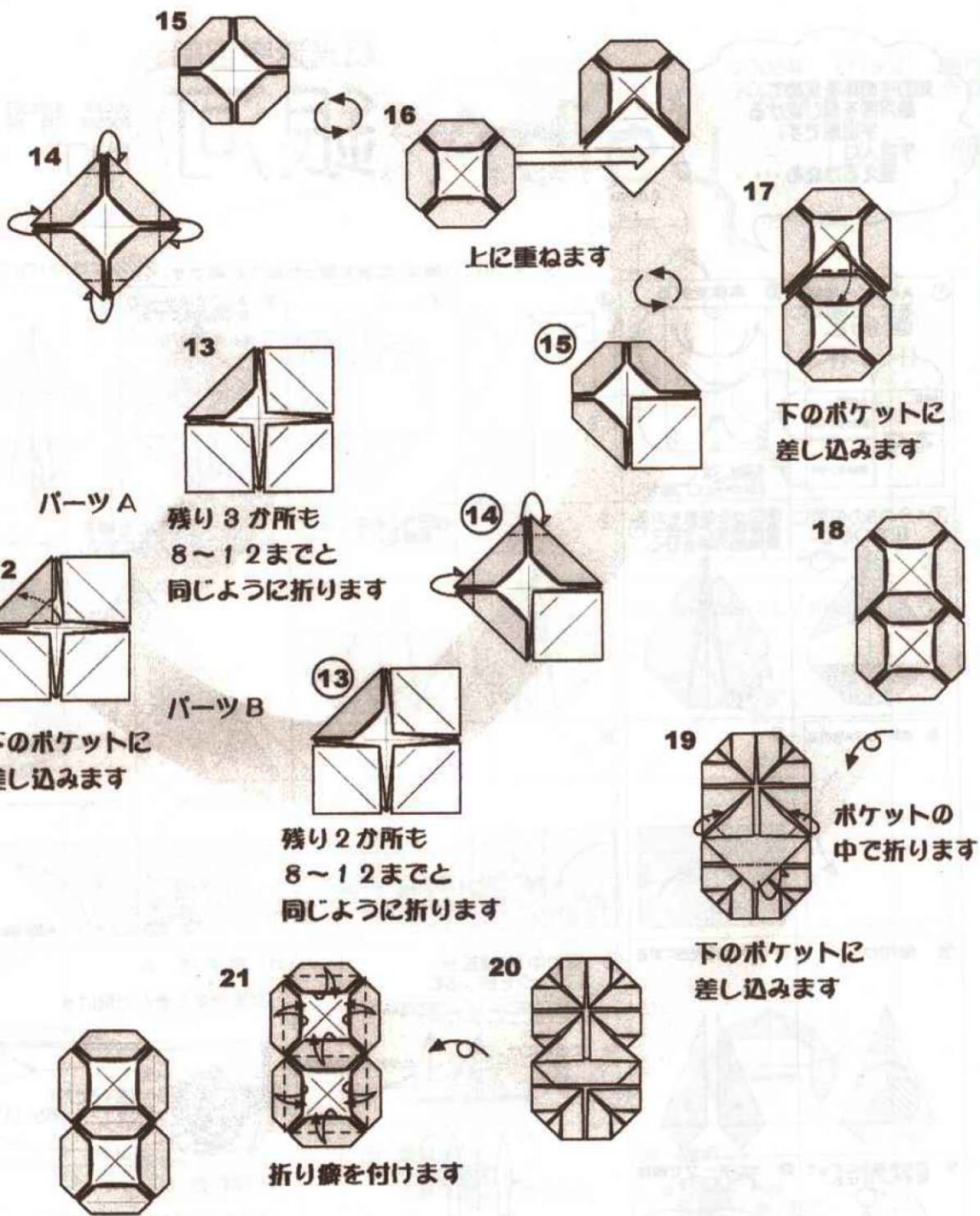

超光速宇宙船

銀河

2002年 6月20日 制作  
2003年 7月 1日 作図

山下 明

知的生命体を求めて、  
銀河間を飛び続ける  
宇宙船です。  
宇宙人に  
運えるかなあ・・・

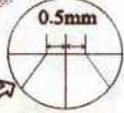
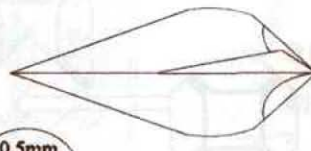

⑤、⑥、⑩の谷線は、定規を使ったほうが楽です。 (斜線) は糊付けの印です。

<p>① A4コピー用紙を三つの部分に切り分ける。</p>	<p>② 本体を折る</p> <p>先鋒は、①まで、0.5mmくらいづつ開けてく。</p>	<p>③</p>	<p>④</p>	<p>⑤ ※ここで「0.5mm」がなくなるはずですが、</p>	<p>⑥</p>
<p>⑦ 4分の3の位置に印をつける。</p>	<p>⑧ 印から谷線を折る。分度器などを使って斜線部の線をひく。</p>	<p>⑨</p>	<p>⑩ 三角の斜面に沿って谷線を折る。</p>	<p>⑪ ⑥～⑩でつけた線を右の図になるように折る。</p> <p>※反対側を糊付け</p>	
<p>⑫ 燃料タンクAを折る</p>	<p>⑬</p>	<p>⑭</p>	<p>⑮</p>	<p>⑯ 糊付け</p>	
<p>⑰ タンクBも同様に折る</p>	<p>⑱ 翼の中(斜線部分)にタンクを差し込む</p> <p>※ できるだけ奥へ外側へ</p> <p>この部分の断面図</p>	<p>⑳ 飛ばし方 A</p> <p>丸部分をつまんで飛ばす</p> <p>空母へ着艦するときのフックです・・・、おかしい?</p>			
<p>㉑ 両方を逆側に折って翼を丸くさせる。</p>	<p>㉒ セロテープで補強</p> <p>「ごめんなさい!」折面が壊れてくると丸はつぶれているとみなしてください!</p> <p>鼻線部を少し上げる</p>	<p>㉓ 飛ばし方 B</p> <p>丸部分に爪切りで切りこみを入れ三本つなげた輪ゴムを引っ掛けて飛ばす</p> <p>少し糊付けするとはずれないヨ!</p>			

アデュー

2003年 3月30日 創作  
2003年 7月 1日 作図

# Adieu

山下 明

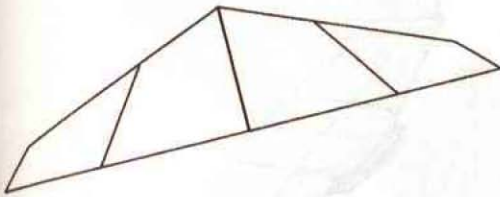

<p>① 15cmの折紙を4等分します。</p>	<p>②</p>	<p>③</p>
<p>④</p>	<p>⑤</p>	<p>⑥ かるく幅付けして折ります。</p>
<p>⑦ 左右の肩を幅付けし、上の線が下の紙の角と合うように折ります。</p> <p>※ つまり、左右とも幅付けし、左右とも折ります。</p>	<p>⑧ 紙の重なるの段差があるところから、辺と角を合わせるように折ります。</p> <p>この辺に紙の重なるの段差がある</p>	<p>⑨ 翼を広げ(戻し)ます。</p> <p>← 90度です。</p>
<p>⑩ 一応、できあがり。でもここから少し形を整えます。</p>	<p>⑪ 翼は水平に、中央の角度は、可能な限り、大きくする。</p> <p>早い話しが、できるだけベッチャンコに！(それでも、優雅に飛ぶぞ！)</p>	<p>⑫ 飛ばし方</p> <p>★印のところを親指と人差し指で上下からつまんで、そっと、押し出すように、飛ばす。</p>

# メーヴェ

2003/4/10

黒川 紀男

アニメ「風の谷のナウシカ」の主人公ナウシカのお機「メーヴェ」をモデルに作りました。

紙が重なり少し折りにくいですが、簡単な調整で軽快に飛びます。

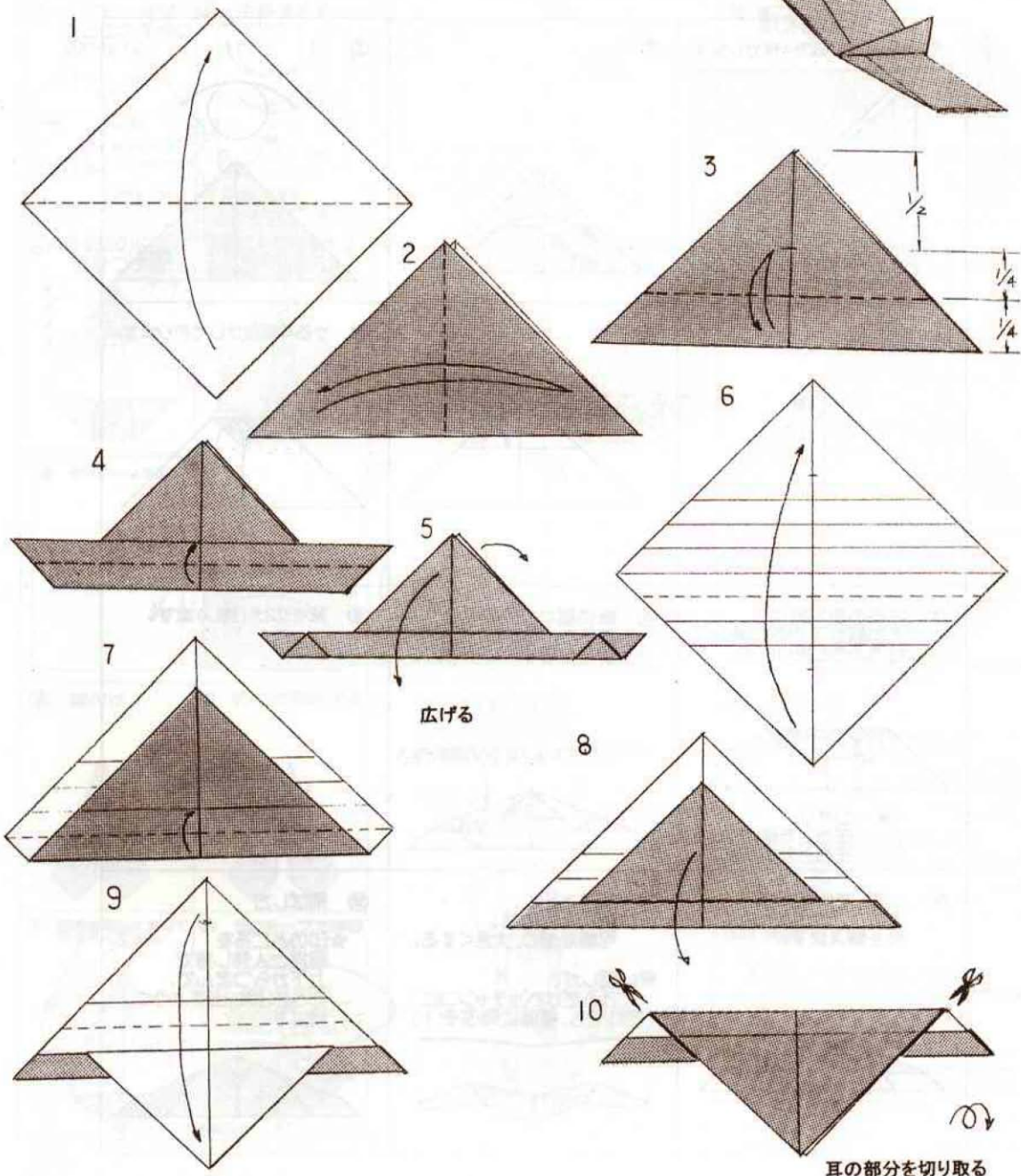
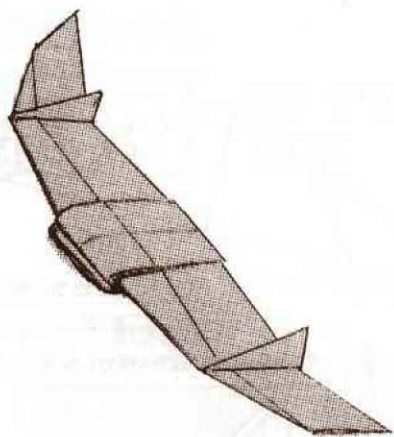

耳の部分を切り取る



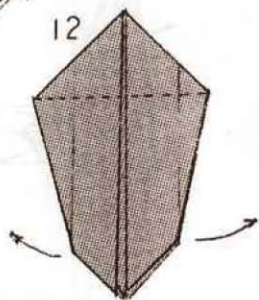
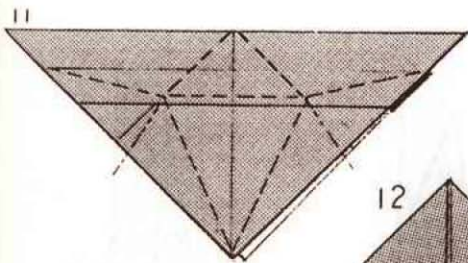

左右に開き引張る

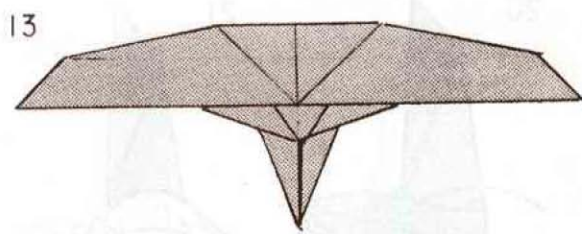

中の部分を引出し2枚にして重ねる

途中図

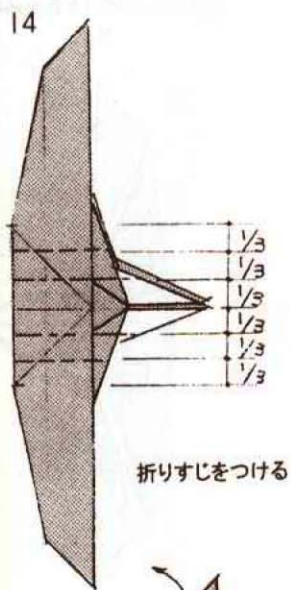
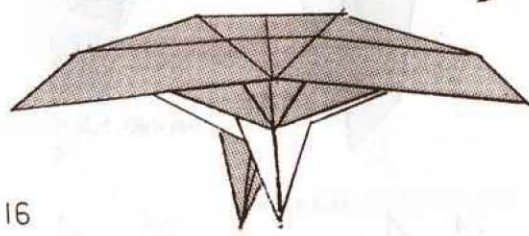

折りすじをつける

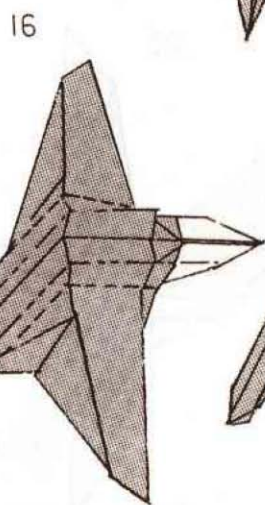
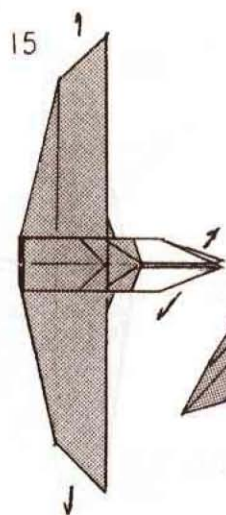

のように折る

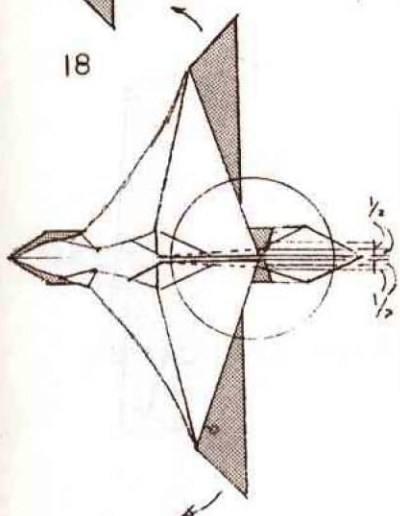
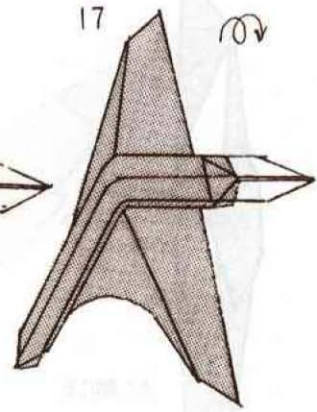

翼の部分を少し前に振る

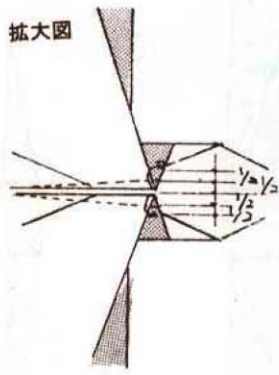

拡大図

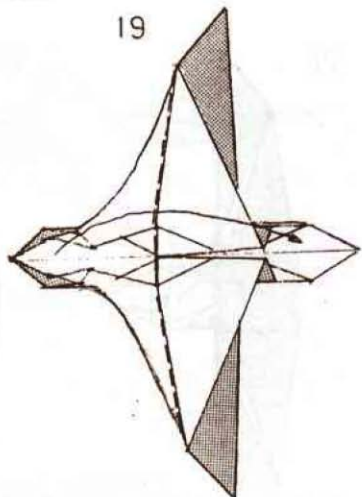

20

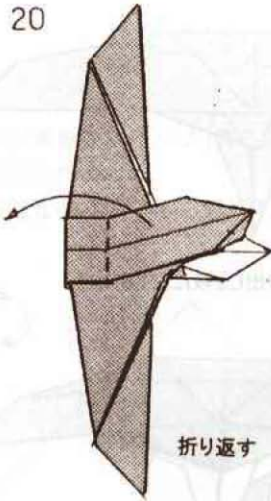

折り返す

21

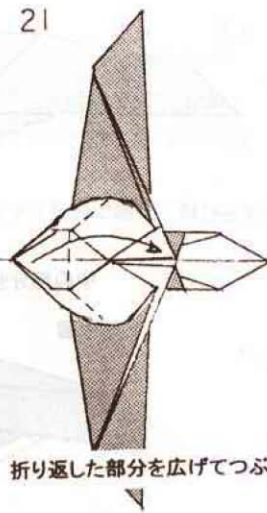

折り返した部分を広げてつぶす

22

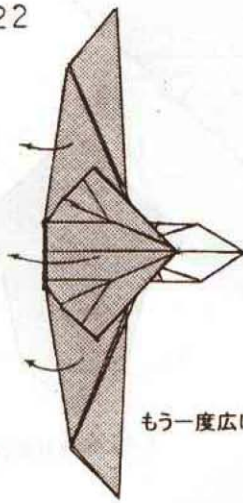

もう一度広げる

23

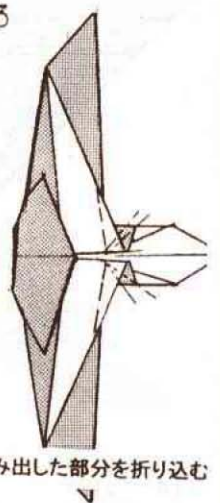

はみ出した部分を折り込む

24

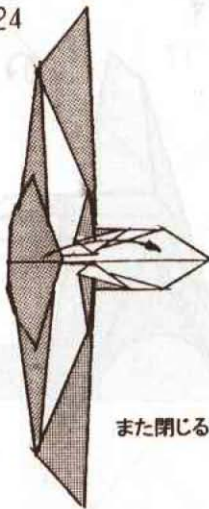

また閉じる

25

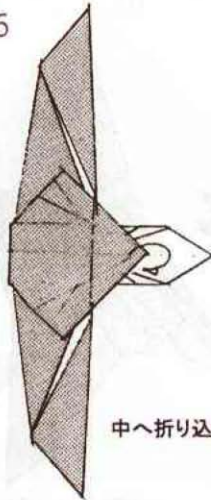

中へ折り込む

26

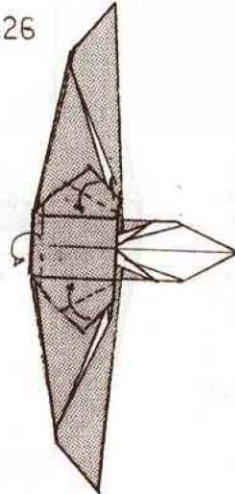

27

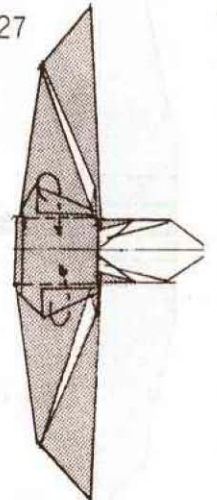

28

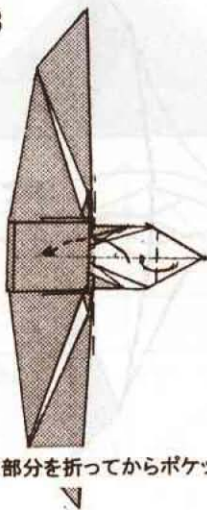

先の部分を折ってからポケットに差込み止める

29



30



31



32

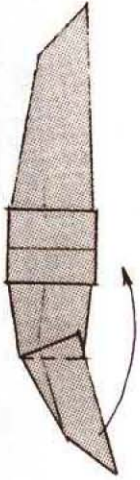

33

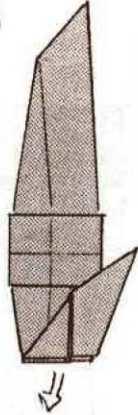

中の部分を引き出す

34

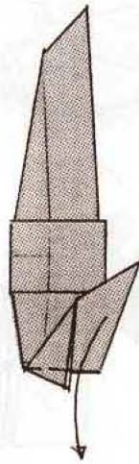

35



反対側も同様に折る(30~34)

36



完成

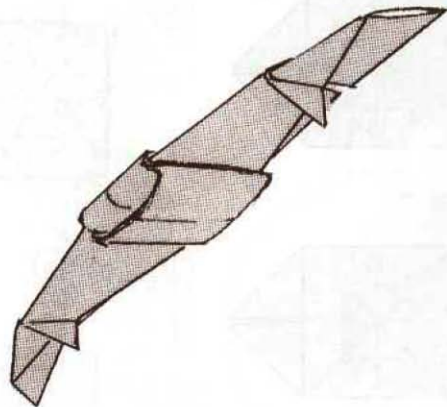
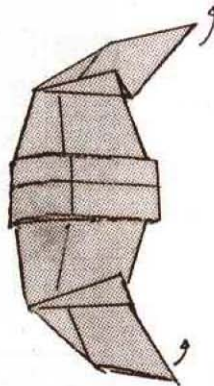

正面図



翼は水平に、翼端の後ろの部分を少し上げる

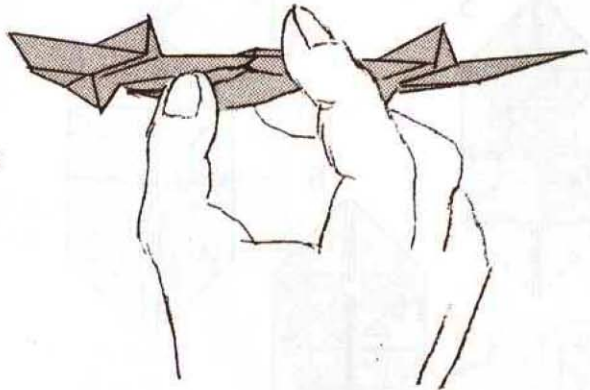

三本の指で持ち飛ばす

# StarShip

2003.02.17

創作：青木 良

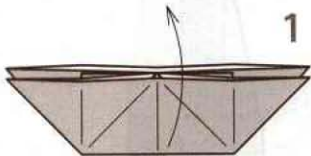
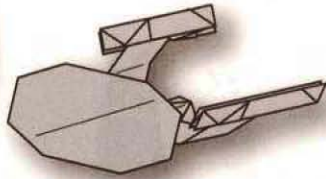

1

(にそうぶねきほんけい)

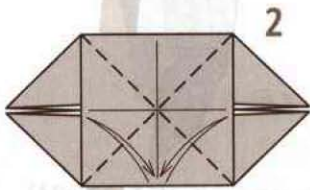

2

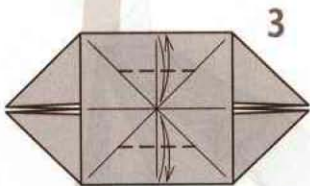

3

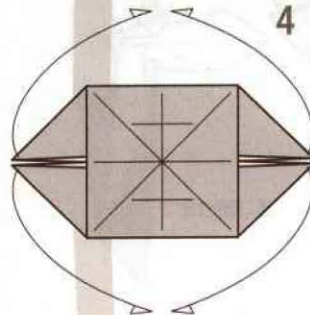

4

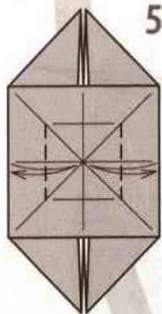

5

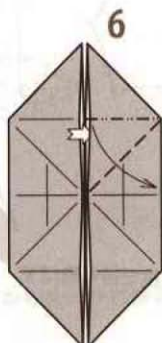

6

ひらいておりたたむ

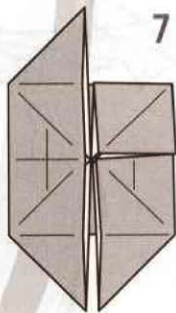

7

のこりの  
3かしょも  
おなじ

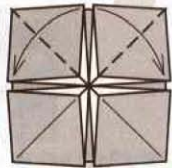

10

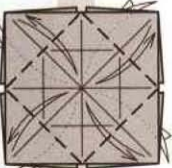

9

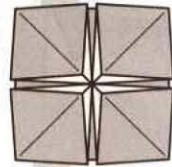

8

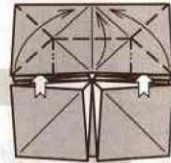

11

ひらいておりたたむ

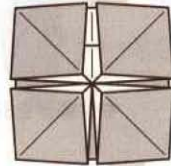

12

のこりの3かしょも  
おなじ

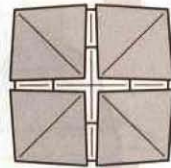

13

よせるよう  
におりたたむ

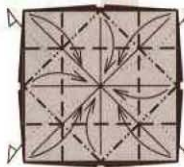

14

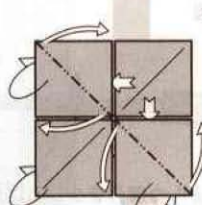

15

ひらいておりたたむ

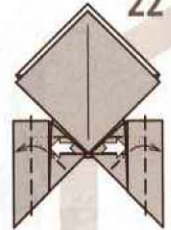

22

ひらいておりたたむ



21

なかわりおり

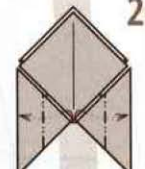

20

なかわりおり  
うらもおなじ

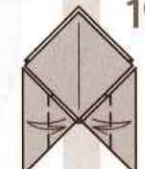

19

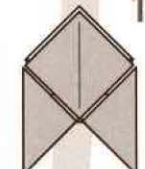

18

うらもおなじ

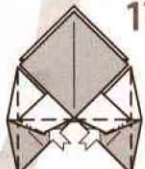

17

(途中図)

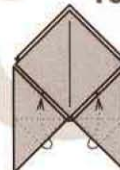

16

なかの  
かどを  
なかわり  
おり

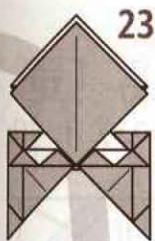

23

うらもおなじ

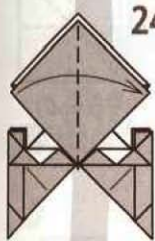

24

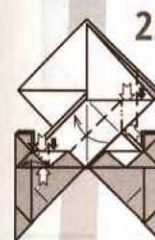

25

ひらいておりたむ

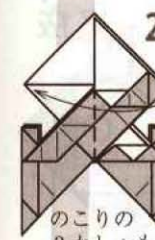

26

のこりの  
3かしょも  
おなじ

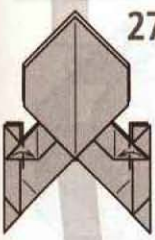

27

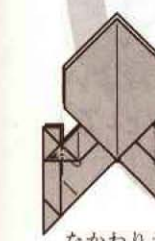

28

なかわりおり  
うらもおなじ

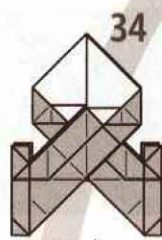

34

のこりの  
3かしょも  
おなじ

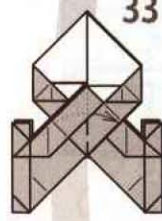

33

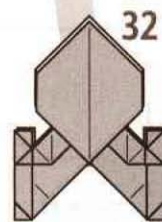

32



30

(部分図)



29

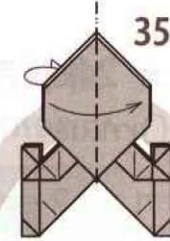

35

ひらいておりたむ



36

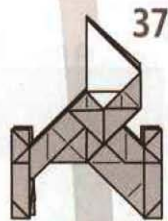

37

のこりの  
3かしょも  
おなじ

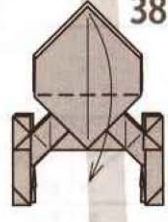

38

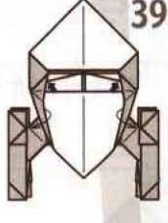

39

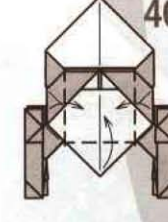

40

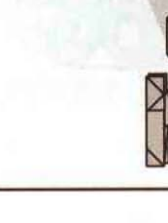

41

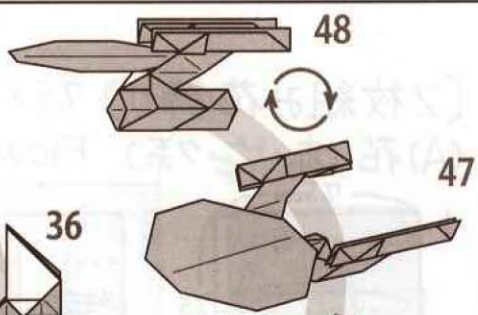

48

47

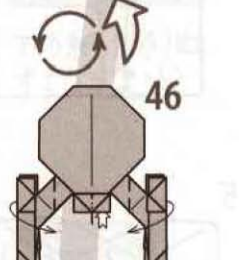

46

りったいにする

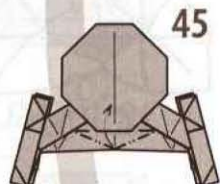

45

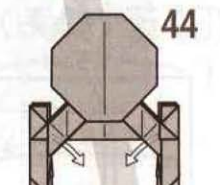

44

なかからひきだす

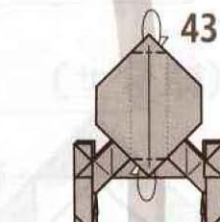

43

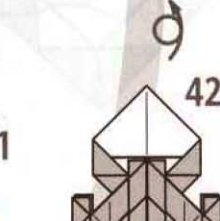

42

[2枚組み花飾り] 7.5 x 7.5 cm 2枚使用

(A) 花 (赤・ピンク系) Flower Ornament (2pieces)

中島 進

H15(2003). 1. 10.

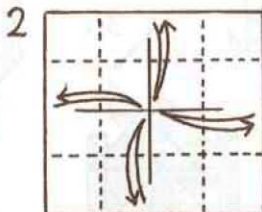
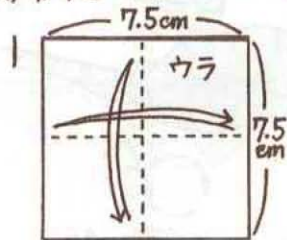

4 x 4 = 16 マスをつくる

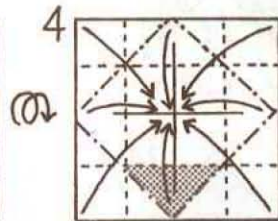

横の三角部分の頂点を中心に寄せる

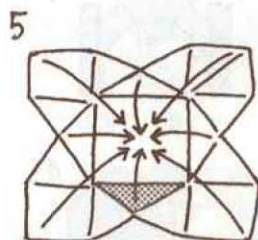

途中図

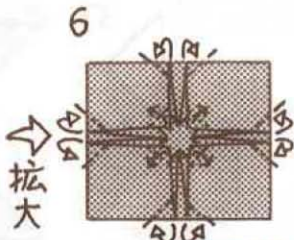

4mm程を直角に折ること

7 花完成

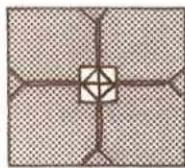

直角

(B) 葉 (緑系)

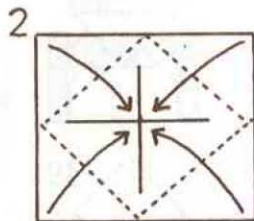
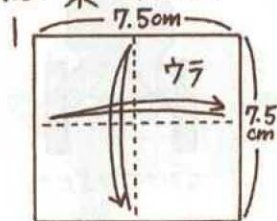

中心に折る

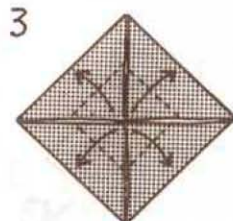

4 葉完成

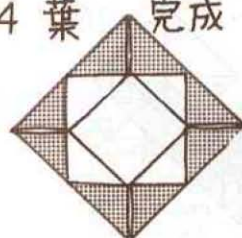

(組合せ)

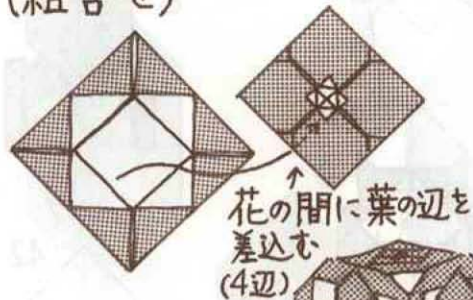

花の間に葉の辺を差込む (4辺)

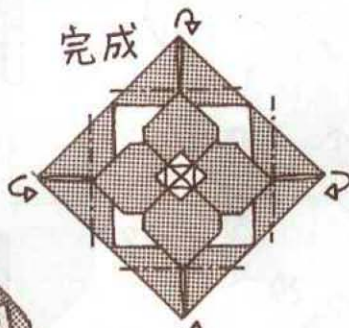

ウラに折ると6枚でクス玉ができる

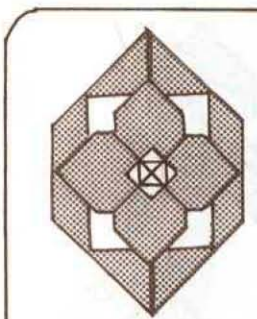

この形もよい (飾りとして)

[www.japaoburajirujin.blogspot.com](http://www.japaoburajirujin.blogspot.com)

[箱] 7.5×7.5cm 1枚 } 計3枚  
 (フタ) 15×15cm 2枚 }

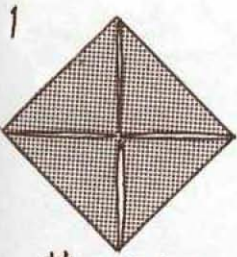

1  
 葉の3より  
 (座ぶとん折)

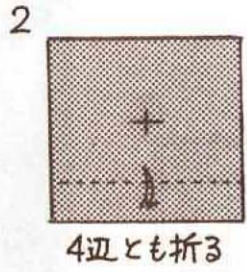

2  
 4辺とも折る

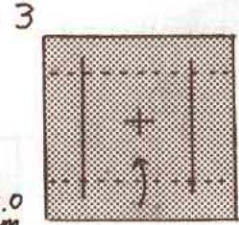

4  
 下の紙を引出す  
 (ウラより)

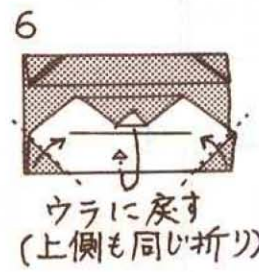
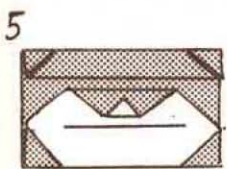

6  
 ウラに戻す  
 (上側も同じ折り)

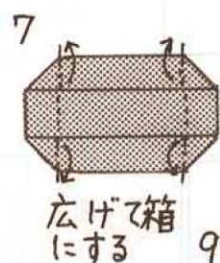

7  
 広げて箱  
 にする

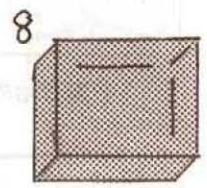

8  
 9フタ完成

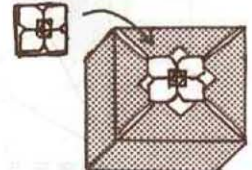

中に花を入れる

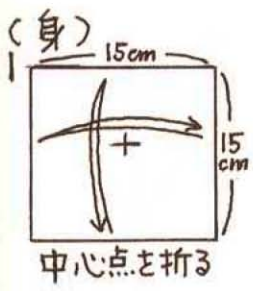

1  
 中心点を折る

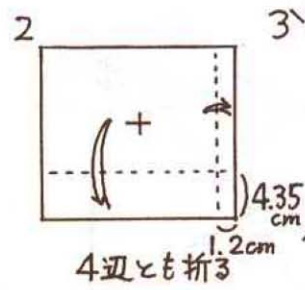

2  
 4辺とも折る

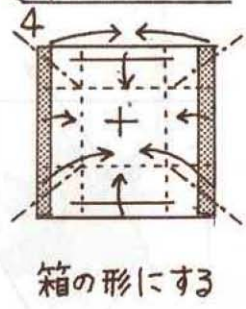
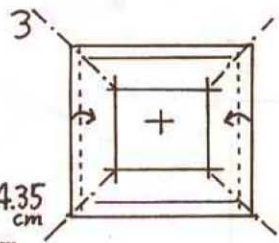

4  
 箱の形にする

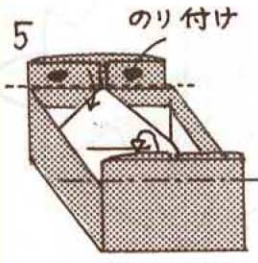

5  
 のり付け  
 ういている所は  
 のり付けする

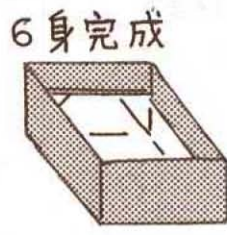

6 身完成



7 箱完成

フタと身を合わせ完成

# 桜 田中稔憲・作・図

花卉 5cm 角くらいの紙で折ります

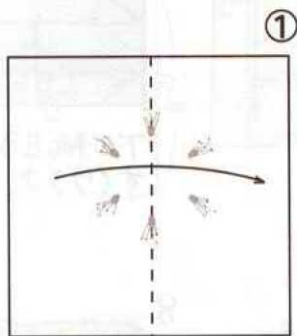
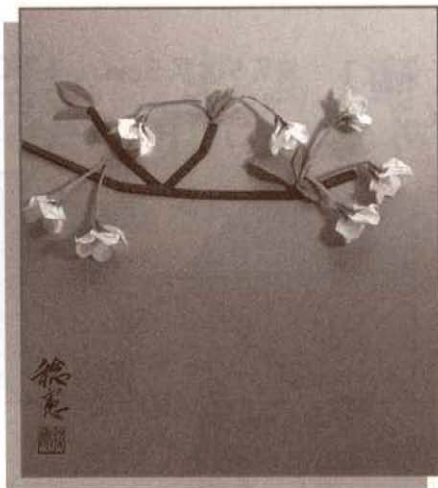

中表で始めます

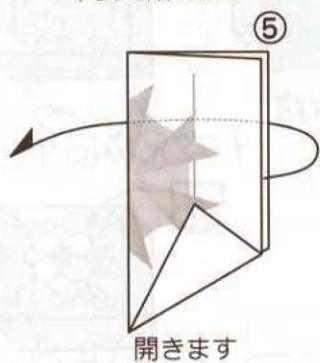
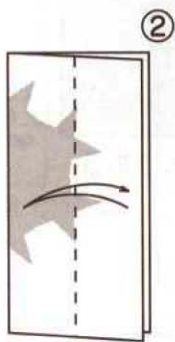

開きます

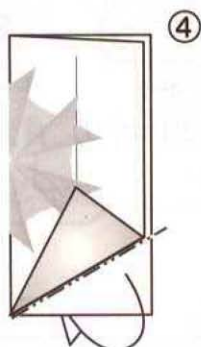

裏も同様に

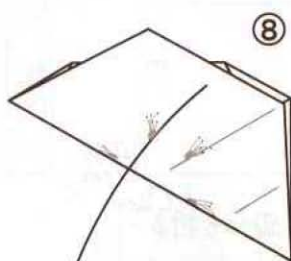
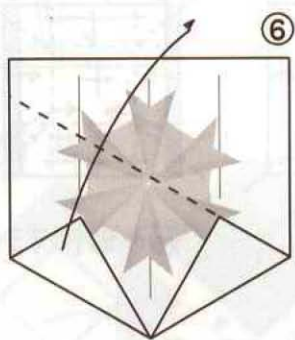

開きます

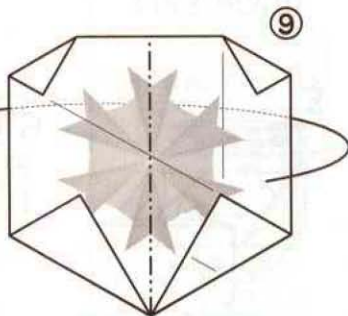
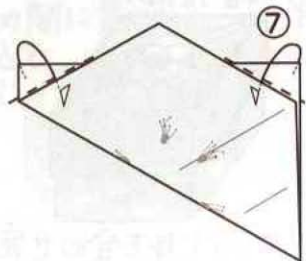

以下印刷した模様を省略し、表面を塗りで示します



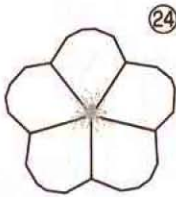

表

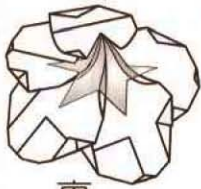

裏

できあがり

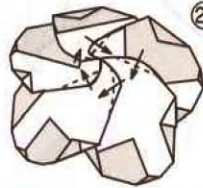

中途を折って萼が出るようにします

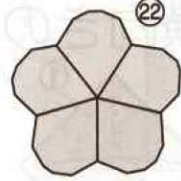

22

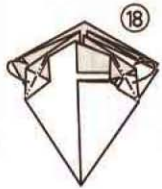

18

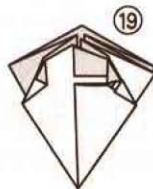

19

あとの3カ所も同様

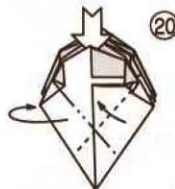

20

ねじり折りしてひろげます

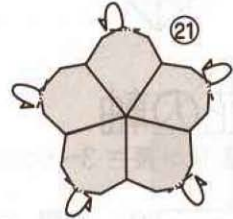

21

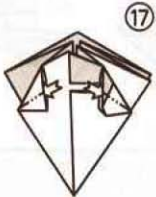

17

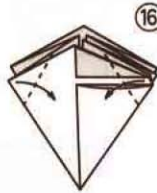

16

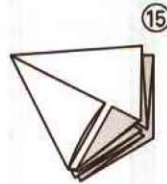

15

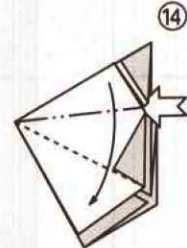

14

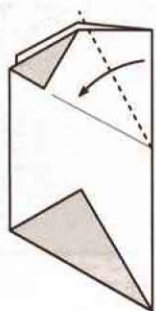

10

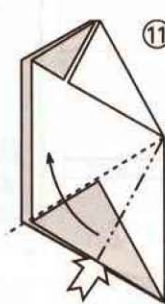

11

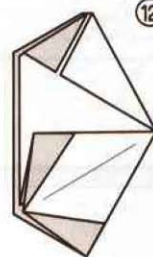

12

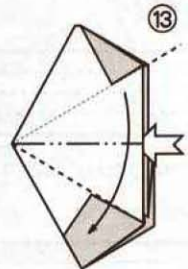

13

### 開いた葉

2cm 角~3cm 角の紙で折ります

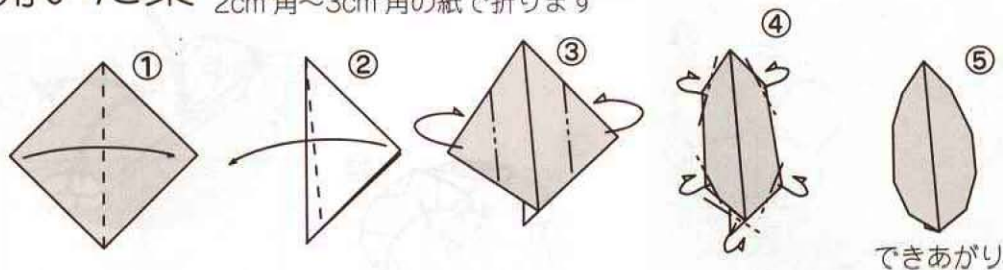

できあがり

### 横向きの葉

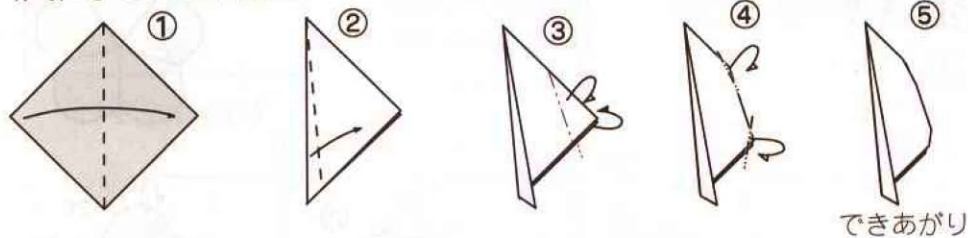

できあがり

### 花の軸

幅 1cm 長さ 3~5cm の紙で折ります

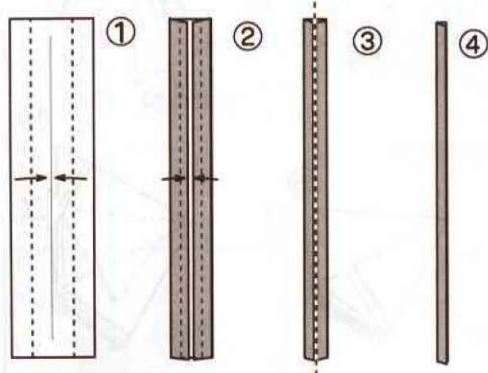

### 花の軸のつけね

1cm 角の紙で折ります

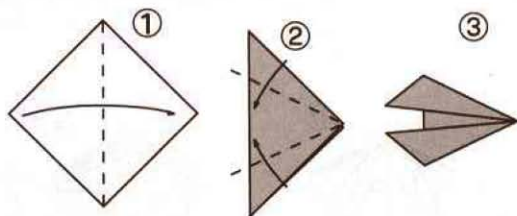

### 枝

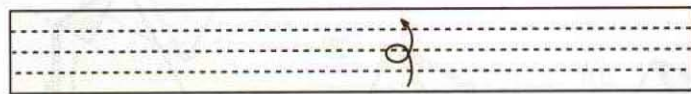

4つ折りにします



自由に折り曲げます

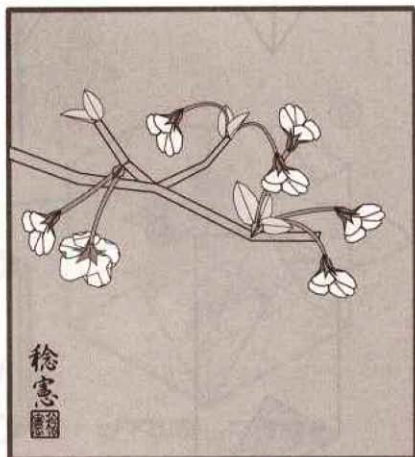

このように飾ります

Created 20030413  
Drawing 20030704

# ホイップ / Whip

川村みゆき

©2003 Miyuki Kawamura

「第 8 回コンベンション折図集」に載せた「セレス」という作品のバリエーションの1つです。6枚、12枚、30枚組み等が可能です。  
"Whip" is a variation of "Celes(Origami Tanteidan 8th Convention)". You can make some models with 6,12,and 30 units.

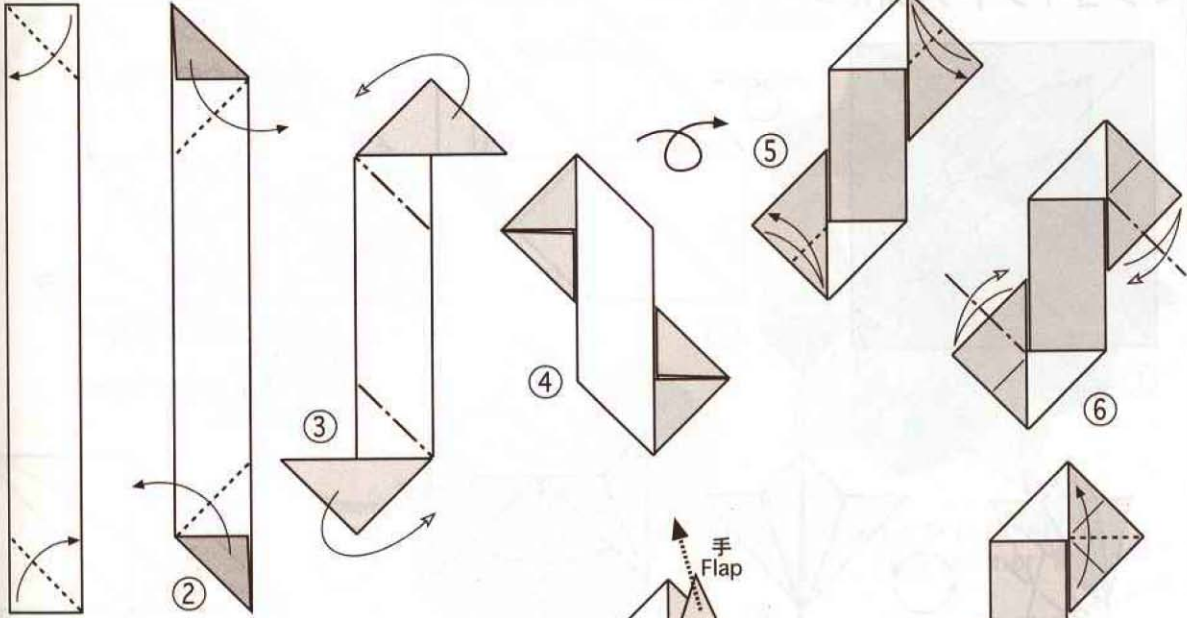

① 長方形用紙  
Rectangular  
1:8

ポケット (下の袋)  
Pocket  
(the under one)

ポケット (下の袋)  
Pocket  
(the under one)

手 Flap  
手 Flap  
ユニットできあがり  
The Whip unit

差し込む  
Insert

上から見たところ  
Top view

5枚組んだところ  
5 units

30枚組み  
30 units

# ウェッジ / Wedge

川村みゆき

©2003 Miyuki Kawamura

Created 20030403  
Drawing 20030704

ジョイントと頂点で合計 20 枚使います。同じ大きさの正方形用紙を使って下さい。  
You need 20 square pieces of paper, all the same size.

## < ジョイント / joint >

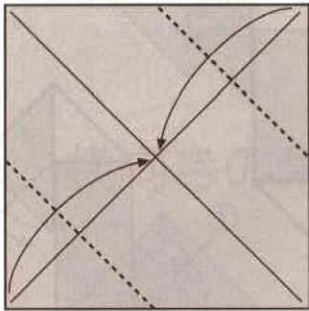

①

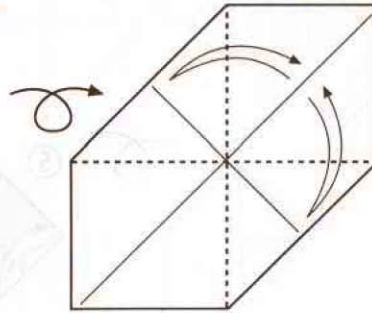

②

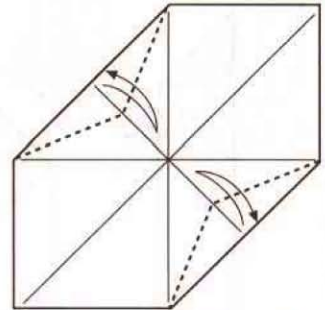

③ 上の紙だけに折り目をつける。  
Fold only upper layer and unfold.

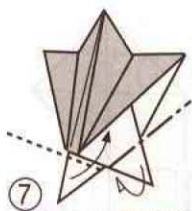

⑦ 2つの角を折ってとめる。  
Fold and lock the flaps.

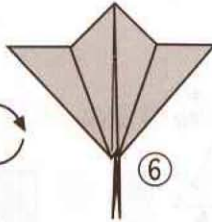

⑥

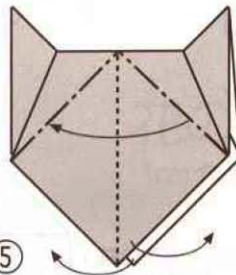

⑤

左右を引き寄せ、中で2枚の三角形を重ねて立体化する。  
The model is no longer flat.

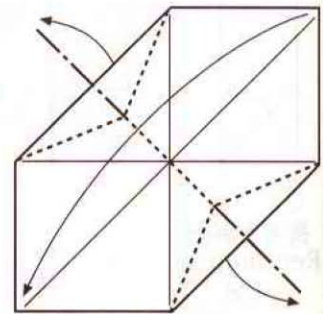

④

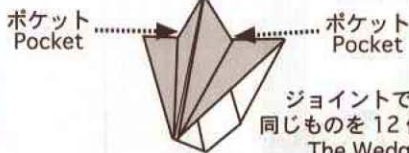

ジョイントできあがり  
同じものを12個作ります。  
The Wedge joint  
You need 12 joints.

角を1つだけ開く。  
Unfold one corner

## < 頂点 / corner >

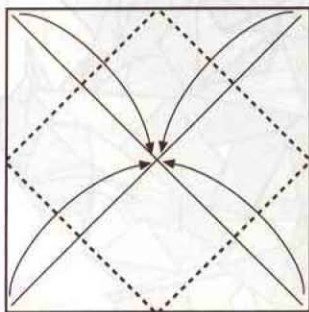

①

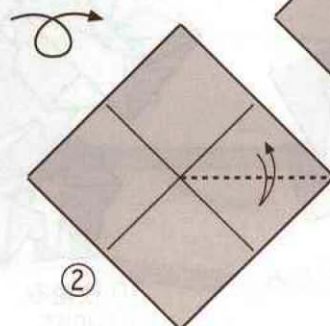

②

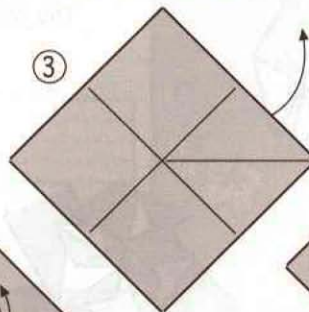

③

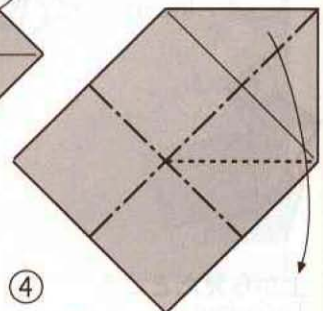

④

引き寄せて立体化する。  
The model becomes 3-D.

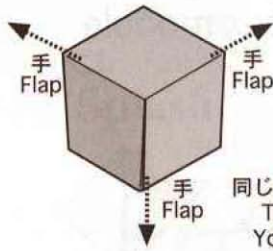
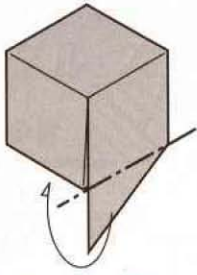

頂点できあがり  
同じものを8個作ります。  
The Wedge corner  
You need 8 corners.

⑤ 角を中へ入れる。  
Tuck the flap inside.

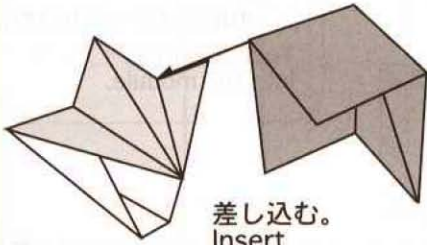

差し込む。  
Insert

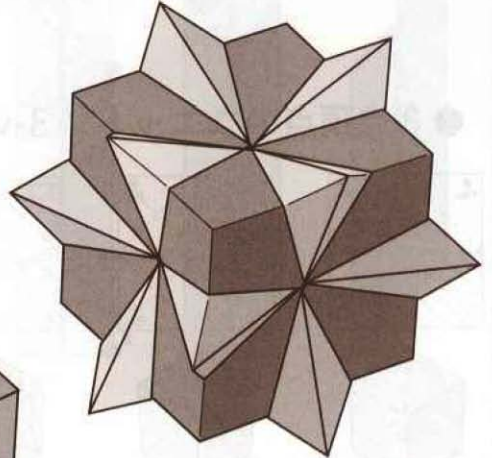
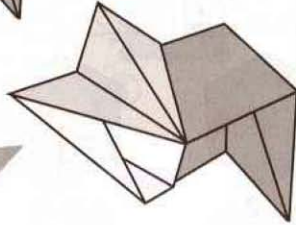

ジョイント / joint: 12  
頂点 / corner: 8

< 発展 / for more fun >

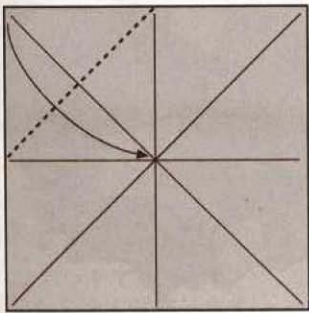

①

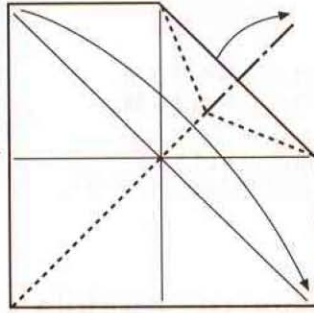

②

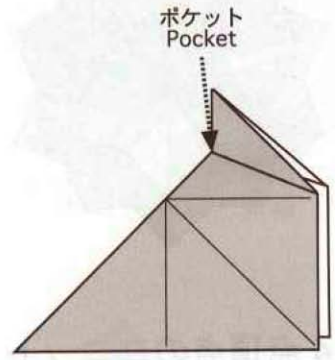

③

ポケット  
Pocket

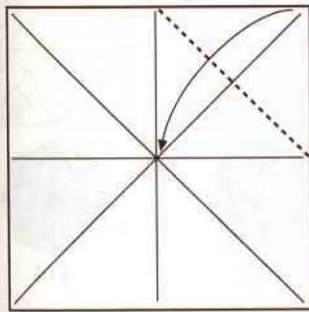

①

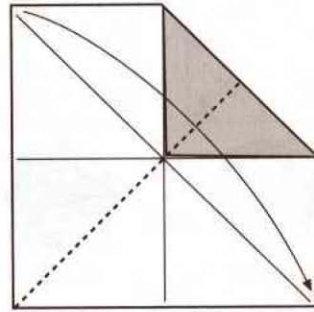

②

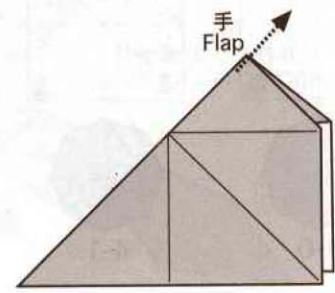

③

手  
Flap

● 2点頂点のユニット / 2-vertex module

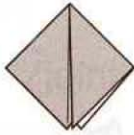
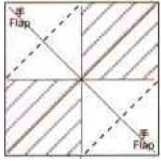

2-0

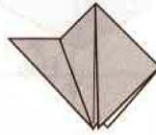
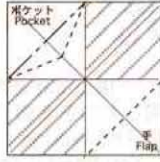

2-1

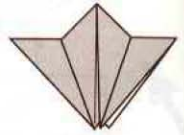
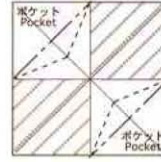

2-2

● 3点頂点のユニット / 3-vertex module

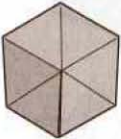
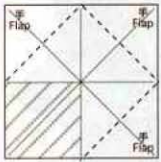

3-0

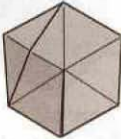
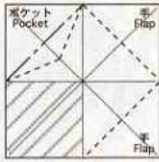

3-1

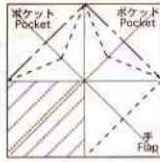

3-2

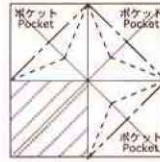

3-3

//// の部分は中へ折り込む。  
Tuck the areas "////"  
into the module.

3-1 ユニットが 30 個、  
3-2 ユニットが 30 個。

You need  
30 modules of "3-1"  
and 30 modules of "3-2".

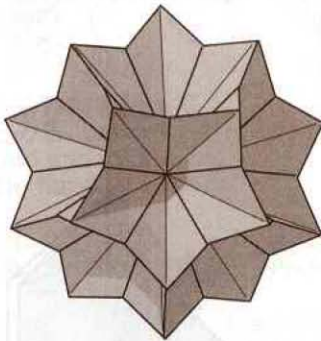

3-1 ユニットが 10 個、  
3-2 ユニットが 10 個。

You need  
10 modules of "3-1"  
and 10 modules of "3-2".

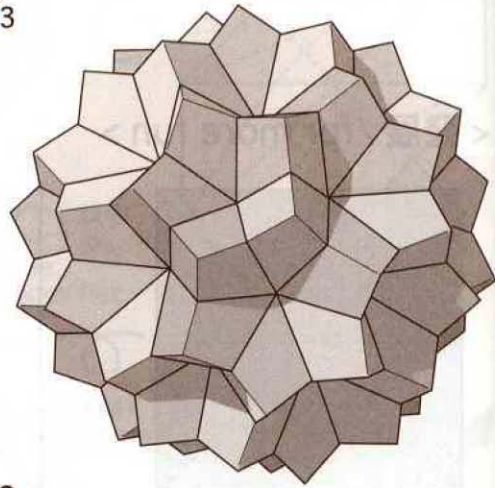

● 4点頂点のユニット / 4-vertex module

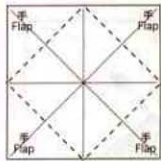

4-0

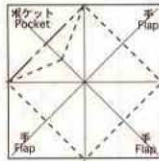

4-1

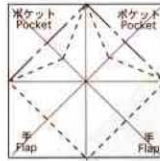

4-2a

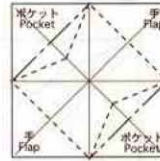

4-2b

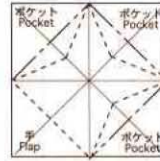

4-3

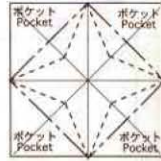

4-4

※ 4-2b ユニットはデビッド・ミッチェルさんの「ジェミニ」のユニットと同じものです。  
The module of "4-2b" is the same as "Gemini" module by David Mitchell.

Created 19970221  
Drawing 20030731

第3回折紙の科学国際会議(2001年3月)で展示した作品です。

# クリスタル・スプラッシュ / Crystal Splash

川村みゆき

©2003 Miyuki Kawamura

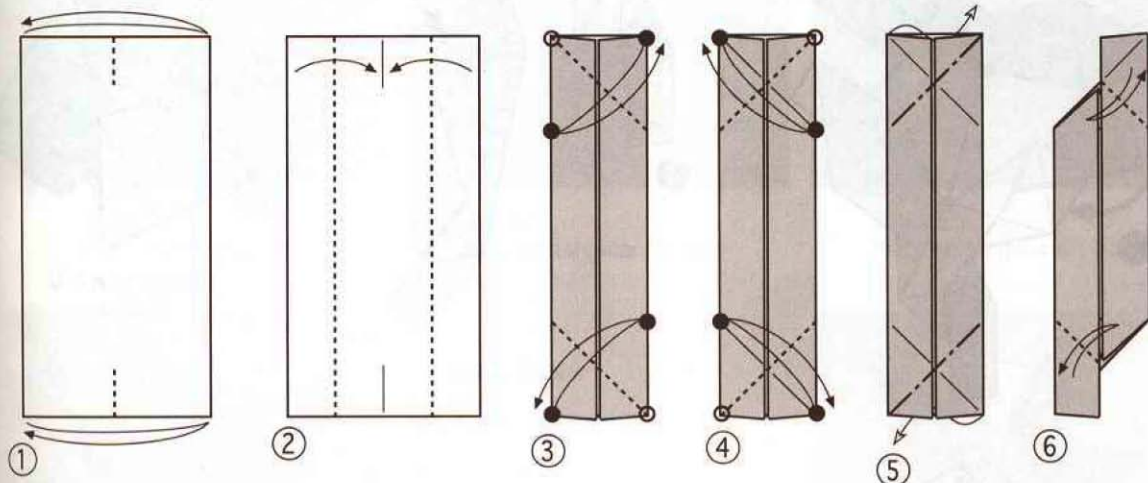

長方形用紙  
Rectangular  
1:2

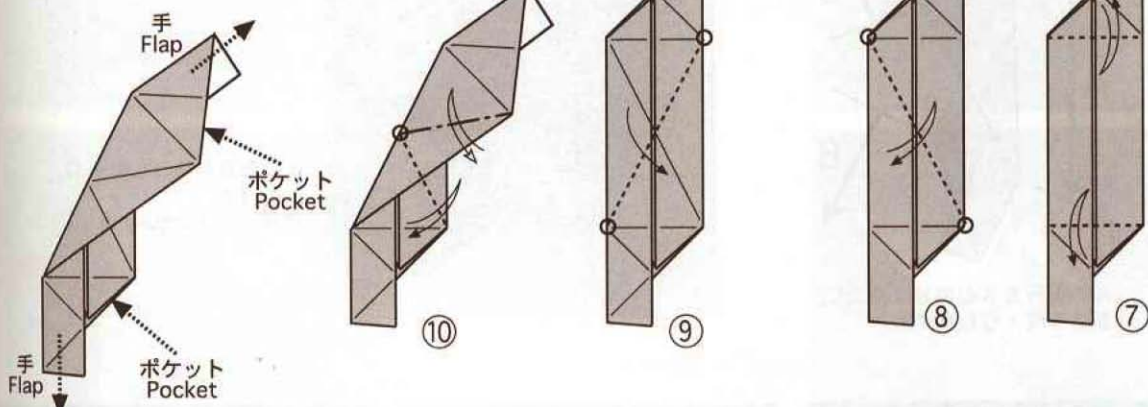

ユニットできあがり  
同じものを6個作ります。  
The Crystal Splash Unit  
You need 6 joints.

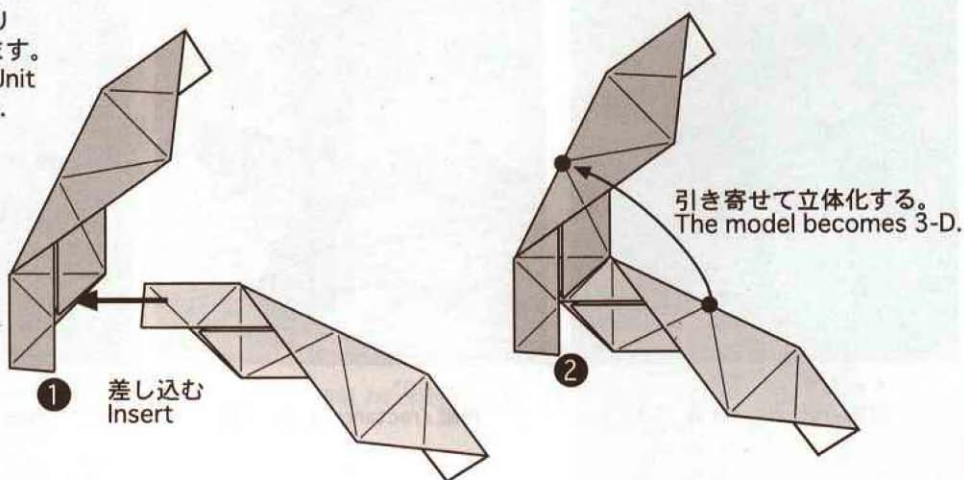

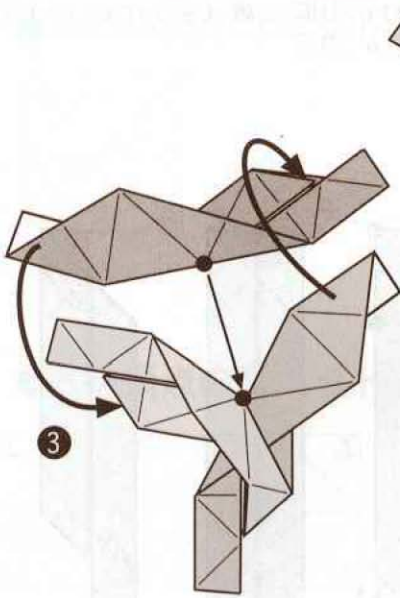

3

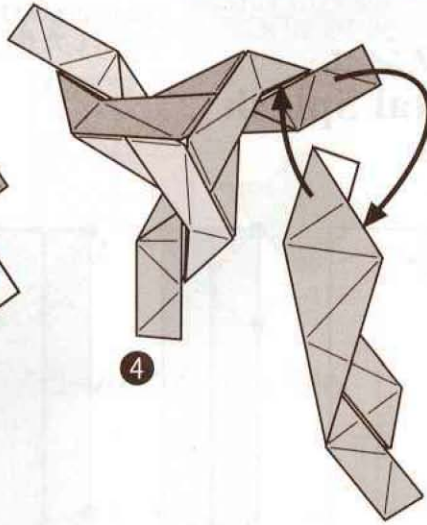

4

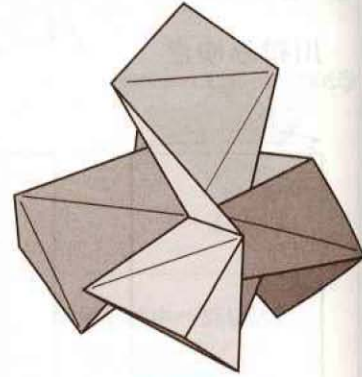

6枚組できあがり  
6 Units

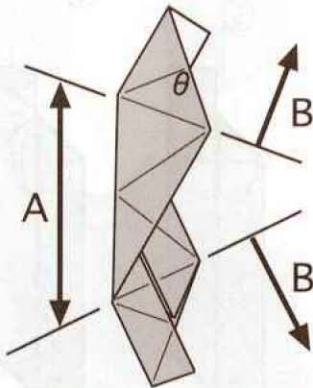

Aの部分とBの部分は独立に  
長さを変えられます。

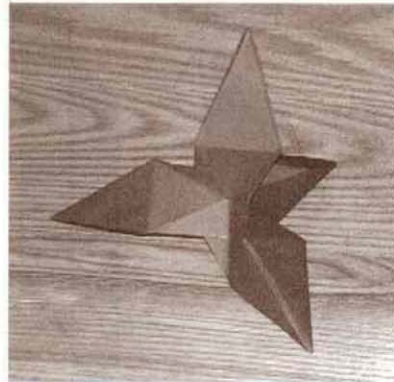

Bの部分を伸ばしたもの。  
 $\theta = 36^\circ$   
用紙 / rectangular 6 : 14.5



$\theta = 60^\circ$   
用紙 / rectangular 6 : 18

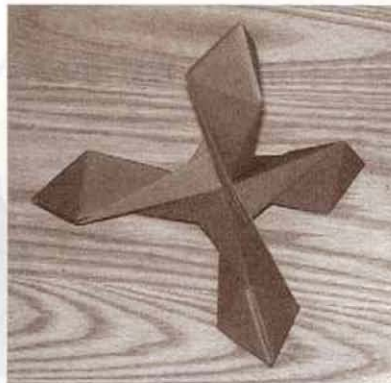

$\theta = 60^\circ$   
用紙 / rectangular 6 : 16

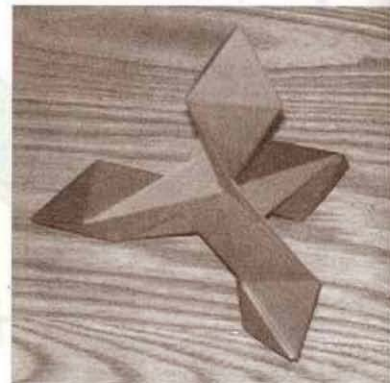

$\theta = 60^\circ$   
用紙 / rectangular 6 : 14



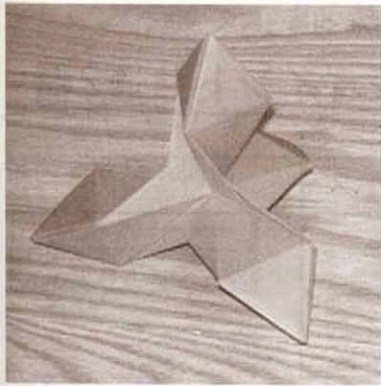

$\theta = 60^\circ$   
用紙 / rectangular 6 : 12

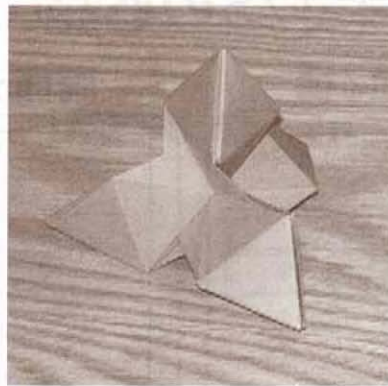

$\theta = 60^\circ$   
用紙 / rectangular 6 : 10

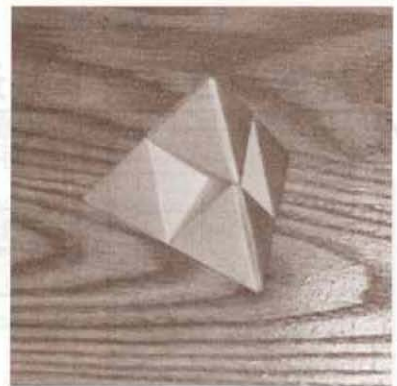

$\theta = 60^\circ$   
用紙 / rectangular 6 : 8.2

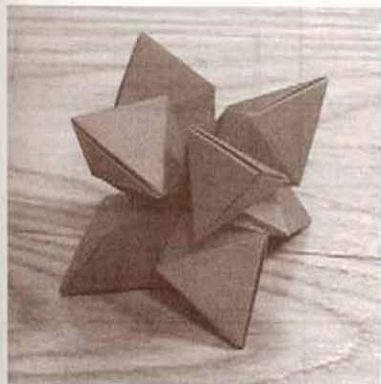

1 2 枚組 / 12units  
 $\theta = 60^\circ$   
用紙 / rectangular 6 : 9.8

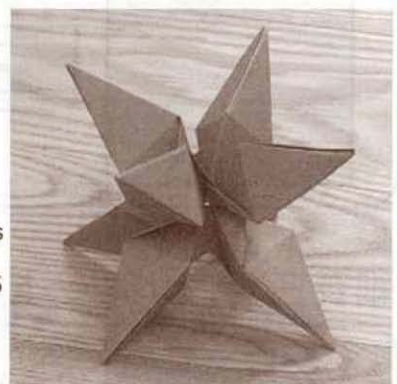

1 2 枚組 / 12units  
 $\theta = 36^\circ$   
用紙 / rectangular 6 : 14.5

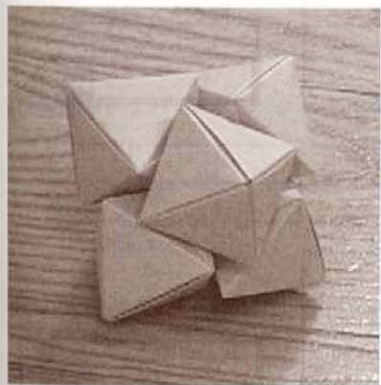

1 2 枚組 / 12units  
 $\theta = 60^\circ$   
用紙 / rectangular 6 : 9.8

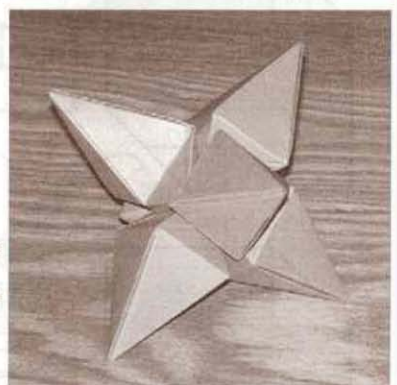

1 2 枚組 / 12units  
 $\theta = 36^\circ$   
用紙 / rectangular 6 : 14

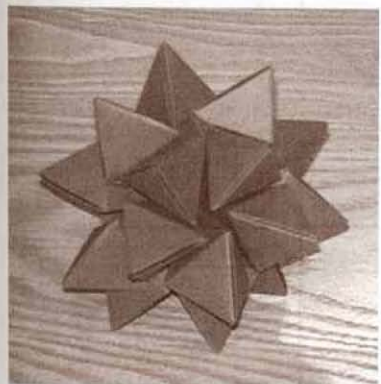

30 枚組 / 30units  
 $\theta = 60^\circ$   
用紙 / rectangular 6 : 11

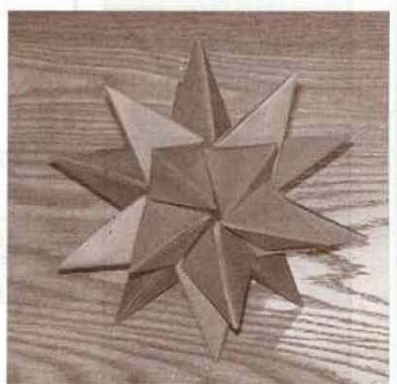

30 枚組 / 30units  
 $\theta = 36^\circ$   
用紙 / rectangular 6 : 14

# 1/3のおび

山田 勝久

## 片面ジョイント共通2種

## 両面ジョイント共通2種

片面Aジョイント

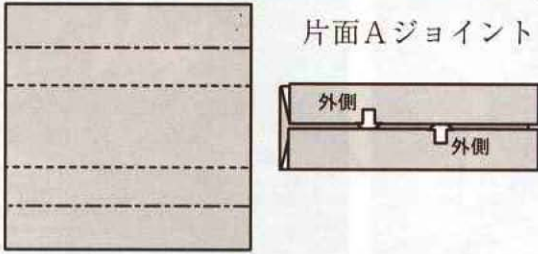

片面Bジョイント

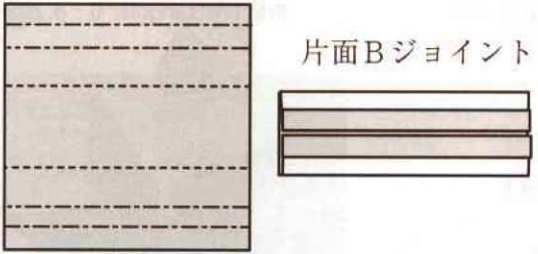

両面Aジョイント



両面Bジョイント



## 細長三角形ユニット用3種

## 12枚キューブユニット用3種

だいたい正三角形ユニット可  
片面A-2ジョイント

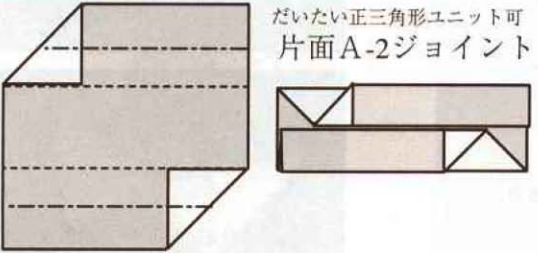

片面B-2ジョイント

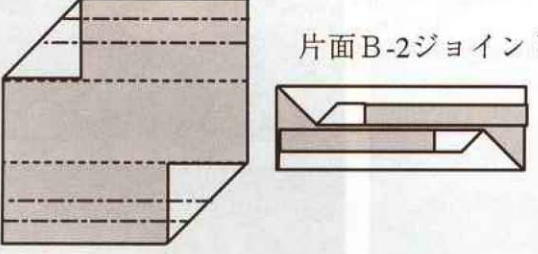

片面Aの変形  
ジョイント

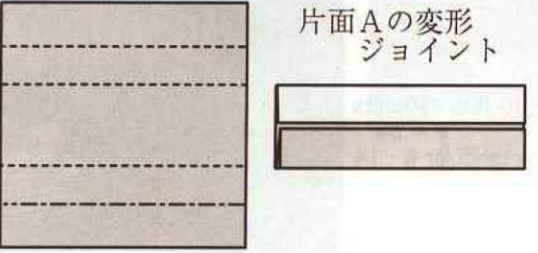

両面A-2ジョイント



両面B-2ジョイント

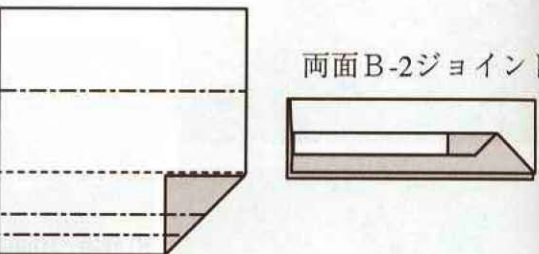

両面Bの変形  
ジョイント

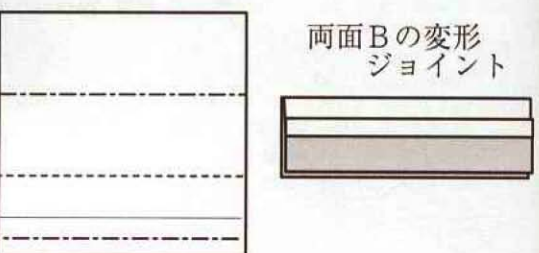

# 1/3のおびユニット

山田 勝久

## 片面ジョイント [片面共通2種 細長三角形ユニット用3種]

だいたい正三角形ユニット [3種]

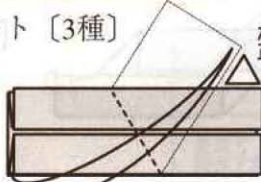
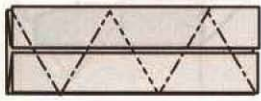

だいたい正三角形に

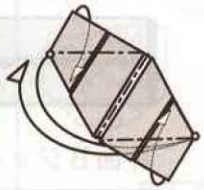
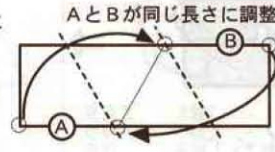

細長三角形ユニット [5種]

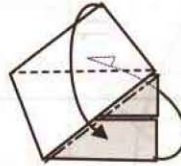
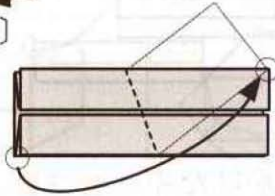
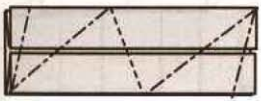

## 両面ジョイント [両面共通2種 12枚キューブユニット用3種]

12枚キューブユニット [5種]

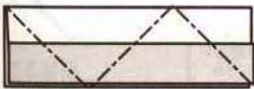

3色×4枚組

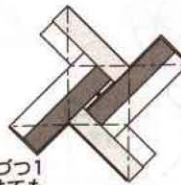
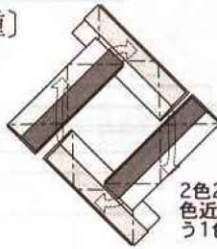

2色2枚づつ1色近づけてもう1色は離す

色つきのおびのカドに3色めのおびを入れる

6枚キューブユニット [2種]



3色×2枚組

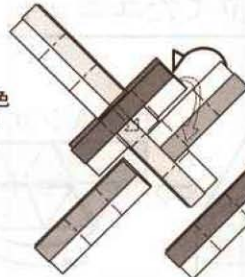
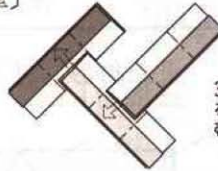

3色のおびの色を外にして組む

同じ色のおびで色をずらして組む

6枚キューブ星ユニット [2種]



6枚キューブユニットに組みおきすじをかえる

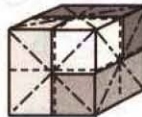

だいたい正三角形の10枚組20面体ユニット [2種]

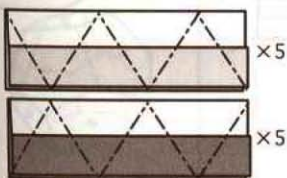

×5

×5

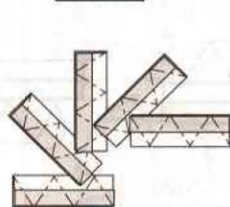

同じ形のおびの色を外にして5枚組む

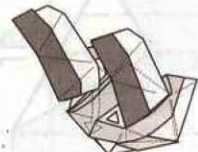
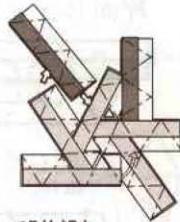

色を下にして三角ができるように組む

布施知子さんの20面体10枚組1/3の作品正三角が4個つながった帯のユニットでしたので、だいたい正三角形のユニットで組んでみました。

# 1/3のおびユニットの仲間

山田 勝久

## そのべ風キューブユニット [2種]

片面Aジョイント

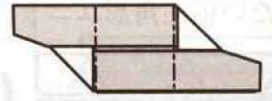
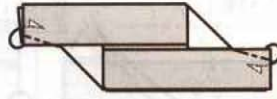
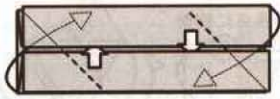

片面Bジョイント

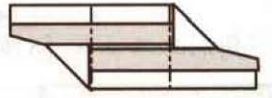
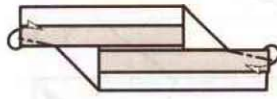
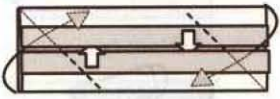

## カドのかけたキューブユニット [3種]

片面A-2ジョイント左右逆

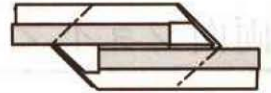
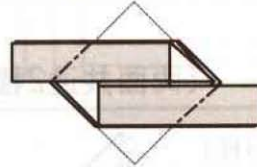
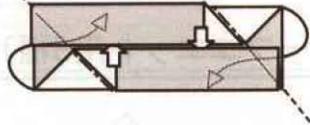

片面Bジョイント

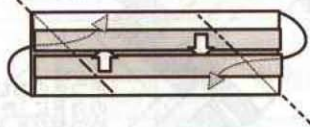

## 正三角形に見立てたユニット [3種]

## あみ込み風ユニット [2種]

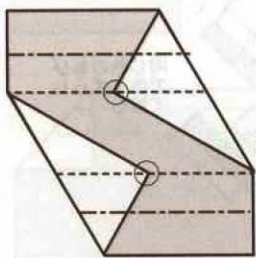

片面Aジョイント

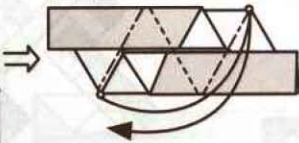

正三角形に見立てた  
ユニット

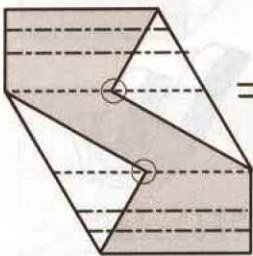
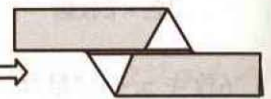
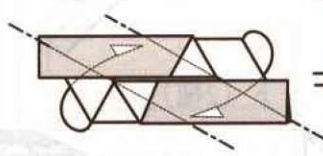

片面Bジョイント

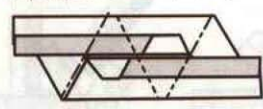

片面Cジョイント  
片面Bジョイントの変化

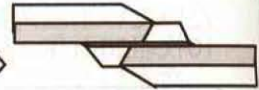
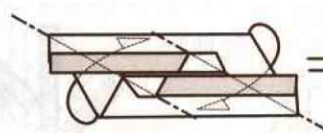

# 1/3のおびユニットのおもな組み合わせ

山田 勝久

ベースになる多面体

キューブのユニット

三角形のユニット

三角形ユニット

カドのかけた  
キューブユニット [3種]

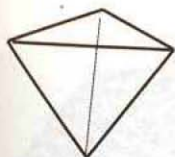

正四面体  
正三角形×4

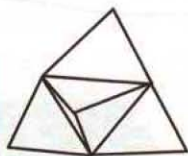

見立て 3種  
細長三角 5種  
だいたい 3種  
合計 11種 ×6枚



見立て 3種  
だいたい 3種  
合計 6種 ×5枚

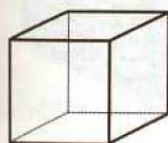
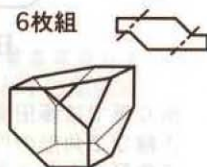

立方体  
正方形×6

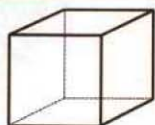

そのべ風 2種×6枚  
12枚キューブ5種×12枚  
6枚キューブ2種×6枚  
合計 9種  
6キューブ=6キューブ星2種

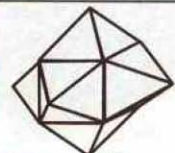

見立て 3種  
細長三角 5種  
だいたい 3種  
合計 11種 ×12枚  
あみ込み風2種 ×12枚

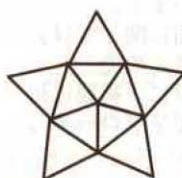

見立て 3種  
だいたい 3種  
合計 6種 ×10枚

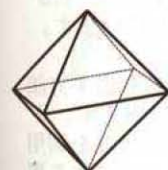
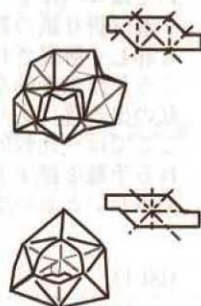

正八面体  
正三角形×8



そのべ風 2種×12枚  
12枚キューブ5種×24枚  
6枚キューブ2種×12枚  
合計 9種

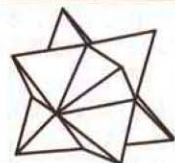

見立て 3種  
細長三角 5種  
だいたい 3種  
合計 11種 ×12枚

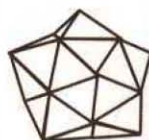

見立て 3種  
だいたい 3種  
合計 6種 ×15枚

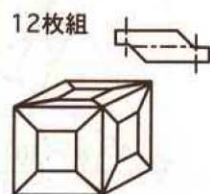

立方八面体  
正方形×6  
+正三角形×8

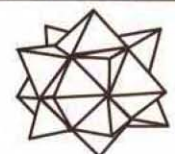

見立て 3種  
細長三角 5種  
だいたい 3種  
合計 11種 ×24枚

細長三角形ユニット



細長三角 5種×6枚

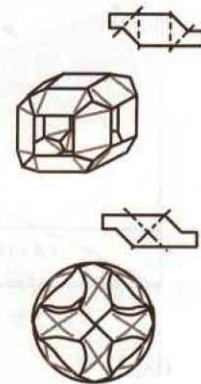

正20面体  
正三角形×20



そのべ風 2種×30枚  
12枚キューブ5種×60枚  
6枚キューブ2種×30枚  
合計 9種

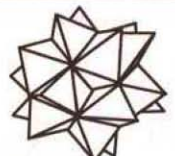

見立て 3種  
細長三角 5種  
だいたい 3種  
合計 11種 ×30枚

だいたい正三角形の  
10枚組20面体ユニット [2種]

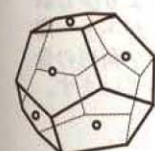

正12面体  
正五角形×12



見立て 3種  
細長三角 5種  
だいたい 3種  
合計 11種 ×30枚  
あみ込み風2種 ×30枚



細長三角 5種×7枚

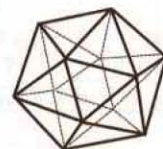

5+5枚

## 7角形の畳紙 I, II

創作/作図  
霞誠志

By Kasumi

折り紙では藤田文章氏の方法により正確な7角形の作図が可能です。7角形を含む正多角形の作図法についてはロベルト・ゲルトシュレーガー著『折り紙の数学』(※.1)でも詳しく解説されています。こうした数理的な方面に関しては、私が出る幕はありませんので・・・ここでは～比較的簡単に、綺麗に折れる手順を探す方向でアプローチしてみたいと思います。

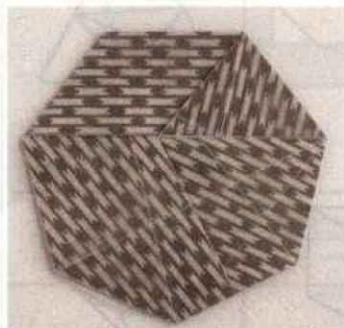

(図.1)

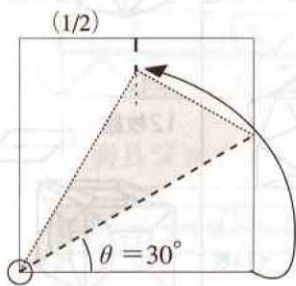

## &lt;角の等分割について&gt;

多角形を折るには必要な角度を得る必要が出てきますので、私が使っている角の等分割方法をいくつか紹介したいと思います。

(1) 良く知られている(図.1)のような $30^\circ$ を折り出す方法を応用すると、角の7等分や9等分が比較的簡単に出来ます。まず、7角形を折るために(図.2)  $\theta = 180^\circ / 7$ の角度を利用するには(図.3)のように規準となる折筋を $X = 3/8$ にする事で $\theta = 90^\circ \times 2/7$ の近似値を得ることが出来ます。この折り方だと誤差は、角度にして $-0.06^\circ$ となります。

また $X = 7/9$ にすると $\theta = 90^\circ \times 3/7 \approx 38.6^\circ$ (誤差は $+0.01^\circ$ )を得ます。

(2)  $X = 15/64$ では9等分  $\theta = 90^\circ \times 2/9 = 20^\circ$ (誤差は $+0.02^\circ$ )、 $X = 6/7$ では11等分  $\theta = 90^\circ \times 5/11 \approx 40.9^\circ$ (誤差は $-0.02^\circ$ )が可能です。<ここで辺を7等分、9等分するにはどうしたら良いのか分からない方もいると思います。そんな方は辺や角の等分割について、ロバートラングさんが[ラング博士の役に立つ幾何学～比を折る] (探偵団新聞55号～60号)の中で詳しく書かれていますので参考に見て下さい>

(図.2)

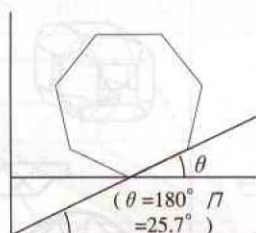

(図.3)

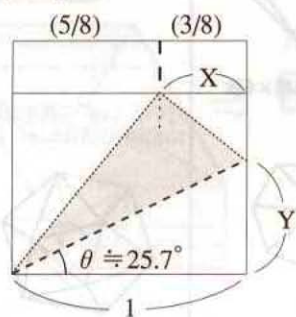

(図.4)

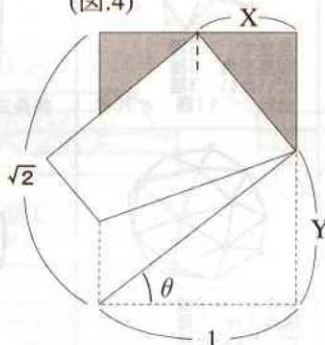

(3) (図.4)のようにして $X = 1/\sqrt{2}$ として、芳賀第一定理折り(※.2)を $\sqrt{2}$ 長方形に対して行うと7等分  $\theta = 90^\circ \times 3/7$ (誤差は $-0.07^\circ$ )を得ることが出来ます。

このほうが $7/9$ 方法より少し誤差が大きいですが・・・簡単に7等分出来るので7角形の畳紙Iではこちらを使っています。

(図.5)

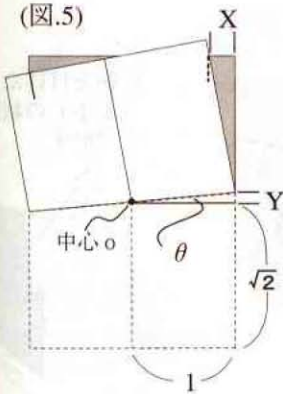

(4) これまでの2つの方法と違って用紙の中心から分割するには(図.5)のようにして中心点を通り、Xに辺を揃えるように折ると15等分や17等分も出来ます。X=1/4にすると拙作の17角形の畳紙に使った17等分(正確には34等分ですが)が出来ます。この場合の誤差は-0.07°です。

#####  
 ※参考：(誤差の計算に使用した：図3~5のXとYの関係式)

$$\tan \theta = Y$$

(図.3)  $Y = \sqrt{\frac{X}{2-X}}$  (図.4)  $Y = \frac{2+X^2}{2\sqrt{2}}$

(図.5)  $Y = \frac{X}{\sqrt{2 + \sqrt{(1-X^2)+1}}}$

#####

<参考文献>

- ※.1 ロバート・ゲルトシュレーガー著、深川英俊訳『折り紙の数学』(森北出版2002年)
- ※.2 芳賀和夫著『ワガミズI(幾何図形折り紙)』(日本評論社1999年)
- ※.3 伏見康治編著『創造性の文化と科学』(共立出版1989年)

\*\*\*\*\*

7角形畳紙 I  
 <sqrt(2)長方形から>

1. 1/2と1/4の折筋を付ける

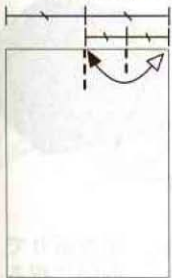

2. O印の部分にだけ折筋を付ける

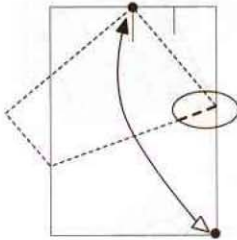

3. 付けた印とカドを結ぶ線で折筋を付ける

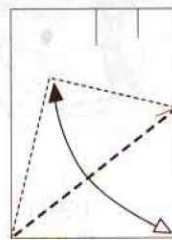

4. O印の部分(交点)にだけ折筋を付ける

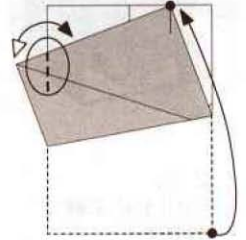

5. 元に戻す

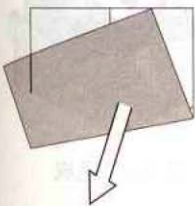

6. 1/2の折筋を付ける

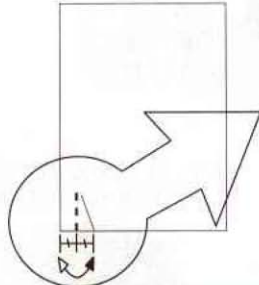

7. さらに1/2の折筋を付ける

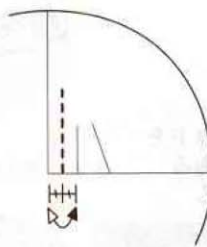

8. つけた折筋に合わせて折る

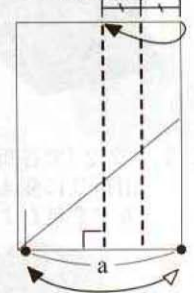

※8. 「a」の幅が完成形の精度に影響します。紙の質や厚みにより微調整して下さい。

「7」で付けた折筋に合わせて折筋を付ける

9. 既にある折筋で中割折り

10. 中割折り

11. 手前の辺に揃うように折る

12. ○印を基点にカドを折筋に合わせて折る

13. 折筋を付けたら「11」の状態まで戻す

14. 折筋を延長して折る

15. ●印を縁に合わせるように折る (山折り線は既にある折筋です)

16. ●印を合わせるように折る

17. 下の紙を引き出して上下を入れ替えながら●印を合わせるように折る

18. 下になっているカドを手前に出す

19. カドを反対側へたおす

20. 縁にそって折筋を付ける

21. 縁にそって折筋を付ける

22. ○印を結ぶ線で谷折り

23. 中割折りで内側に折り込む

24. 中割折りで内側に折る

25. 「22」で谷折りしたカドを山折りに変えて下にあるカドを包むように折る

26. 途中図

27. 下にあるポケットにカドを差し込む

28. 完成

小さなカドは手前の縁に添って中割折り





7角形の畳紙Ⅱ  
＜正方形から＞

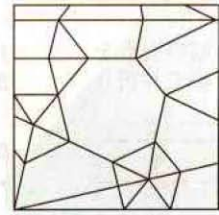

1. 折筋を付ける

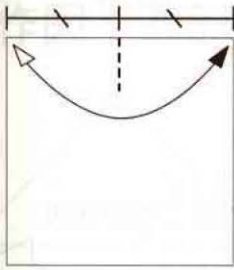

2.

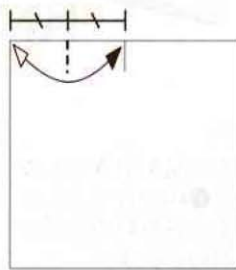

3.

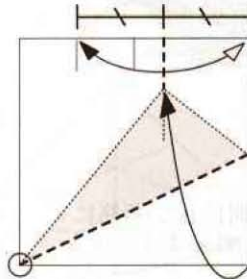

○印を基点に付けた折筋にカドが揃うように折る

4. 縁に合わせるように折る

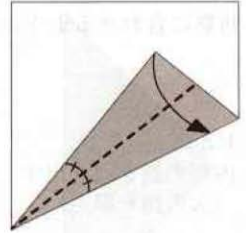

5. 折筋を付ける

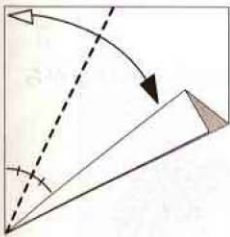

6. ●印を合わせるように折ってから下の部分だけを開く

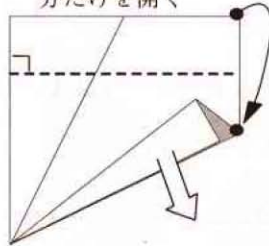

7. ●印を合わせるように折る

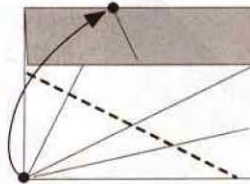

8. 「3」で付けた折筋で中割折り

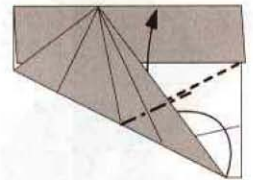

9. ○印を基点にしてカドがA、Cと合うように折る (次の図を参照)

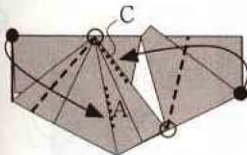

11. カドを反対側へたおす



13. 一旦すべて開く

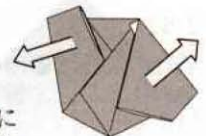

10. 折筋を付けたら戻す

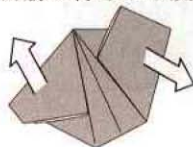

12. ●B、Dの折筋に合うように折る (次の図を参照)

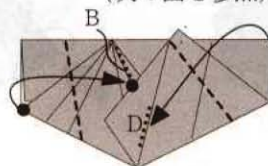

14. 折り筋の交点を通る線で谷折り

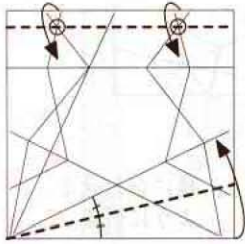

15. 既にある折筋で折る

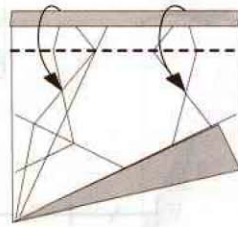

16. 「12」で折った折筋で折る

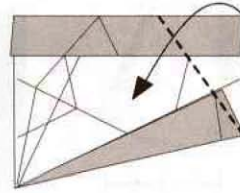

17. 縁に合わせるように折る

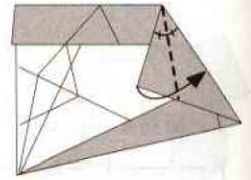

折筋に合わせて折る

18. 内側の紙を引き出す (次の図を参照)

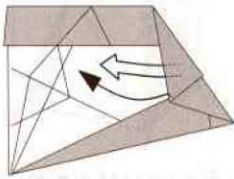

19. (裏側にある)折筋に合わせて折る

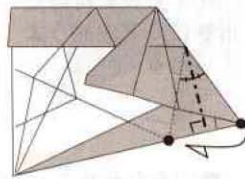

20. 後ろの紙を引き出しながら●印が合うように折ると谷折線の位置が自動的に決まる

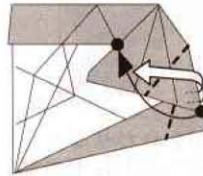

21. 大きく中割り折り

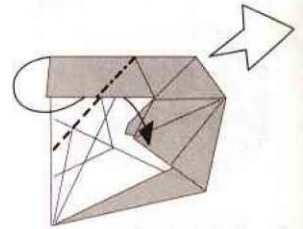

22. ☆印の部分をひろげて引き寄せるように折る

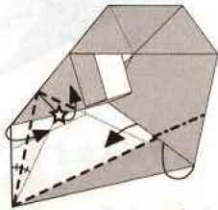

中割り折り

23. 内側が見えるように (折筋は付けない) かるくカドを立てる

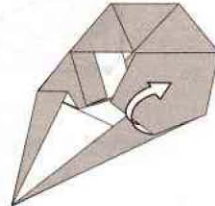

24. ☆印の部分をひろげながら a のカドを立てる

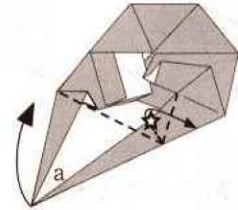

25. ☆印の部分で●印のカドを包むようにして折りたたむ

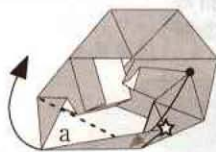

26. 中割り折りでカドを内側に折り込む

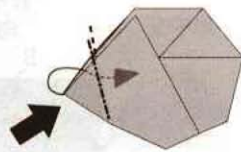

27. 下にあるポケットに a のカドを差し込む

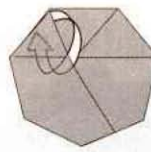

28. 完成



# リス

Squirrel

## 中川 幸治

Kouji Nakagawa

創作：2003年 4月

作図：2003年 4月

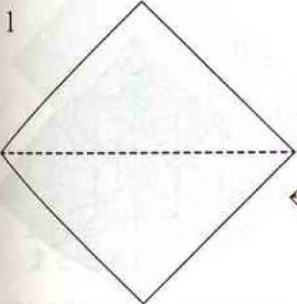
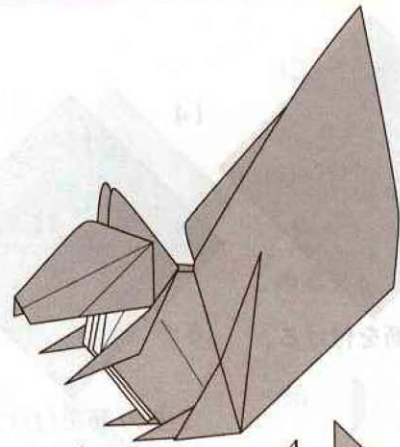

折り筋を付ける。

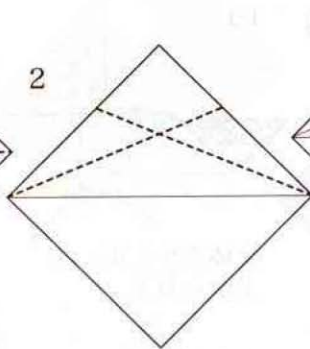

折り筋を付ける。

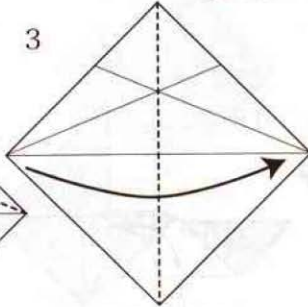

半分に折る。

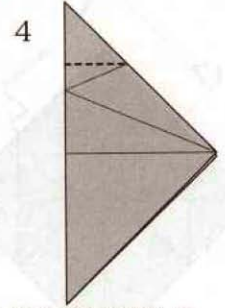

折り筋を付ける。

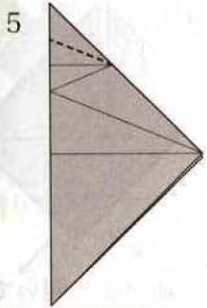

折り筋を付ける。

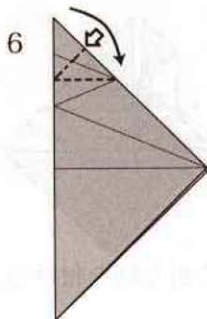

開いてつぶす。

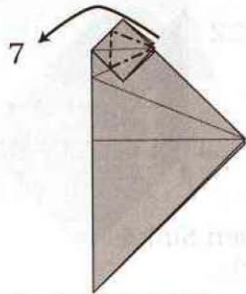

鶴の基本形を作る。

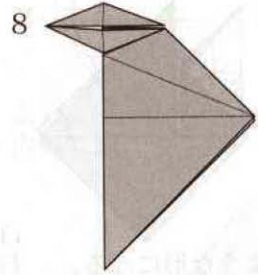

5の状態に戻す。

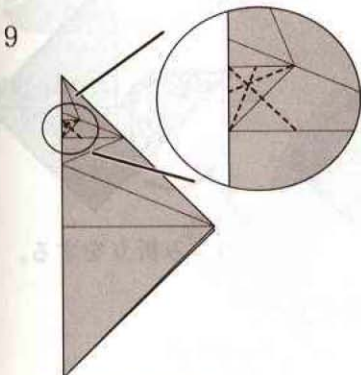

折り筋を付ける。

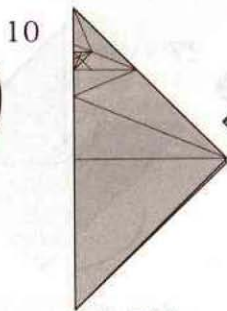

一旦、開く。

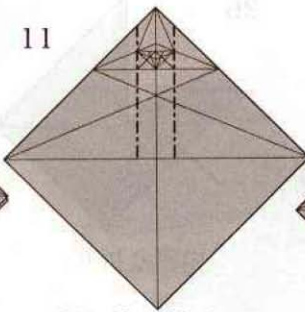

折り筋を付ける。

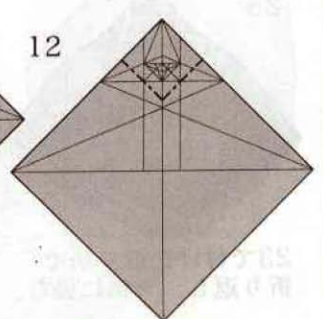

折り筋を付ける。

13

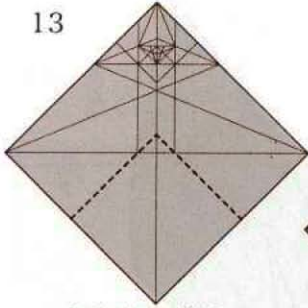

折り筋を付ける。

14

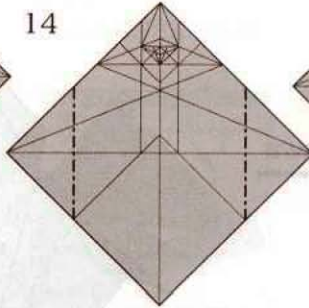

折り筋を付ける。

15

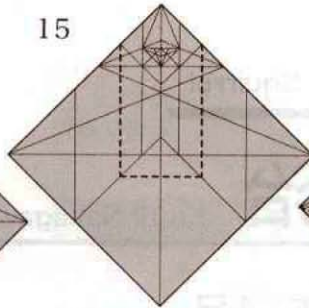

折り筋を付ける。

16

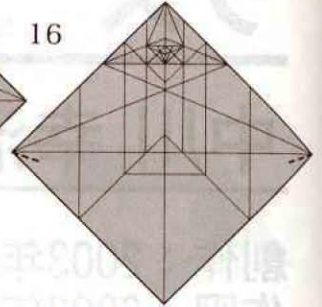

折り筋を付ける。

17

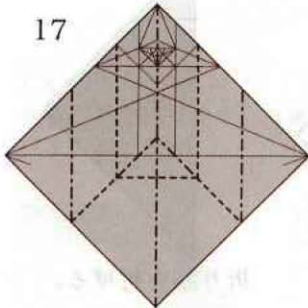

一気に折り畳む。

18

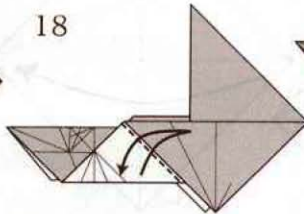

強く折り目を付ける。

19

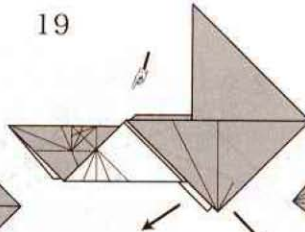

全体を少し開いて  
上から見る。

20

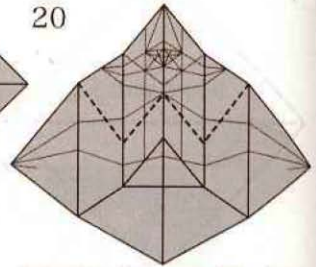

18で付けた折り筋で折り  
返し、一気に畳む。

21

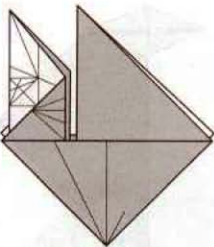

このような形になる。

22



Open Sinkを  
行う。

23

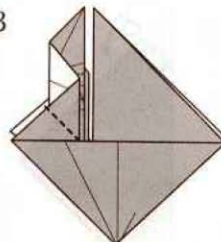

強く折り筋を付ける。

24

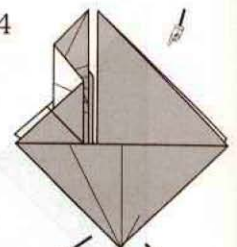

全体を少し開いて  
上から見る

25

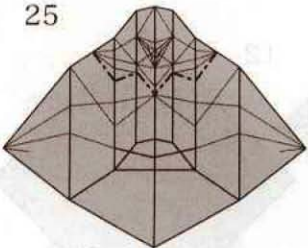

23で付けた折り筋で  
折り返し、一気に畳む。

26

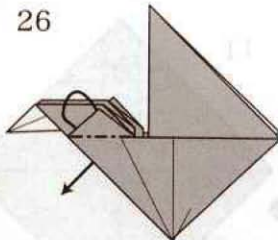

中割り折り。

27

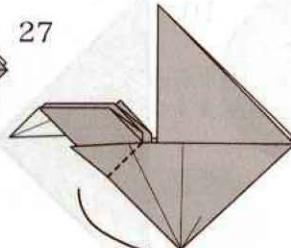

一杯の所で下に折り返す。

28

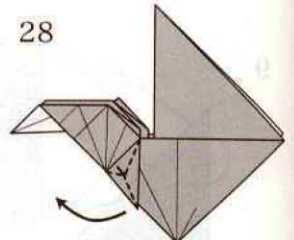

つまみ折りをする。

29

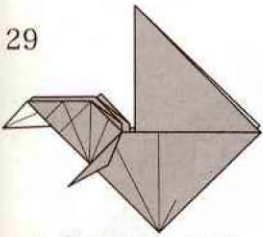

反対側も26~28と同様に折る。

30

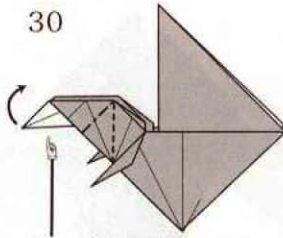

この部分が平らになるように広げる

31

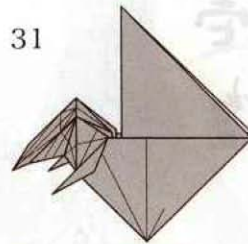

このような形になる。

32

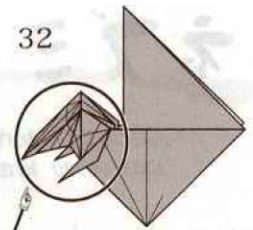

この部分を上から見る

33

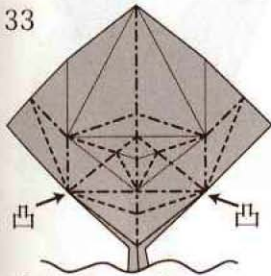

折り筋で一気に入まとめる。

34

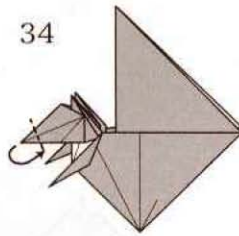

内側に折り込む。

35

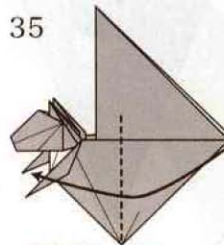

全部折らないように注意!!

36

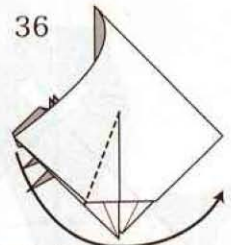

折り返す。この時、凸に膨らむ。

37

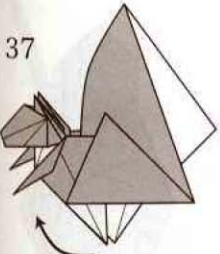

引き出すように中割り折りにする。

38

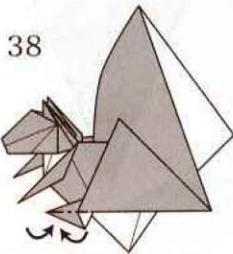

隙間に差し込む。

39

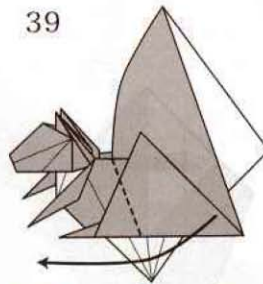

尻尾を広げるように折る。

40

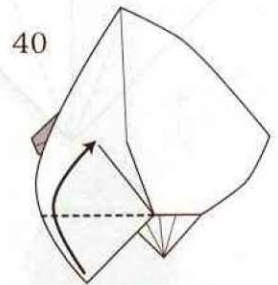

余分な所を尻尾の内側に折り込む。

41

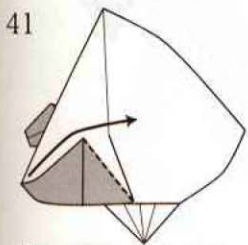

尻尾が膨らむように90度位折る。

43

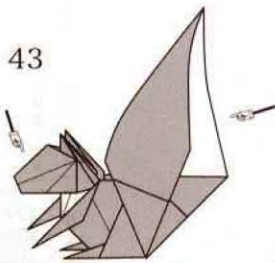

顔を膨らませ、尻尾の形を整えると...

42

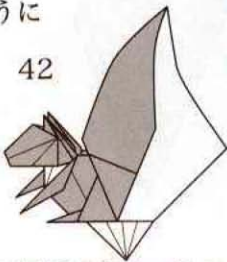

反対側を35~41のように折り

44

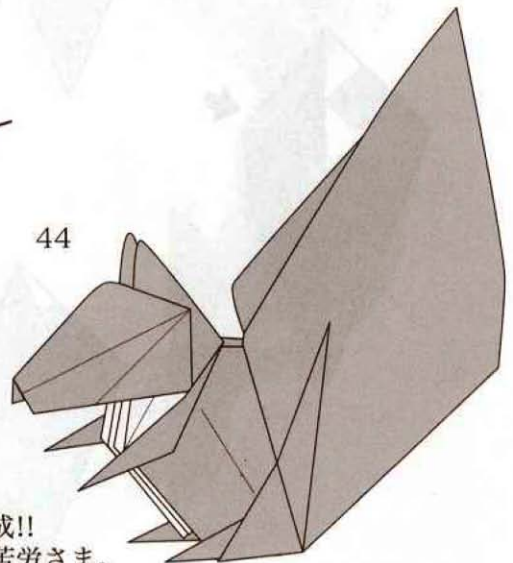

完成!!  
ご苦労さま。

# ネズミ 巻

2002.02.11 制作 初  
2003.06.30 折図 纏

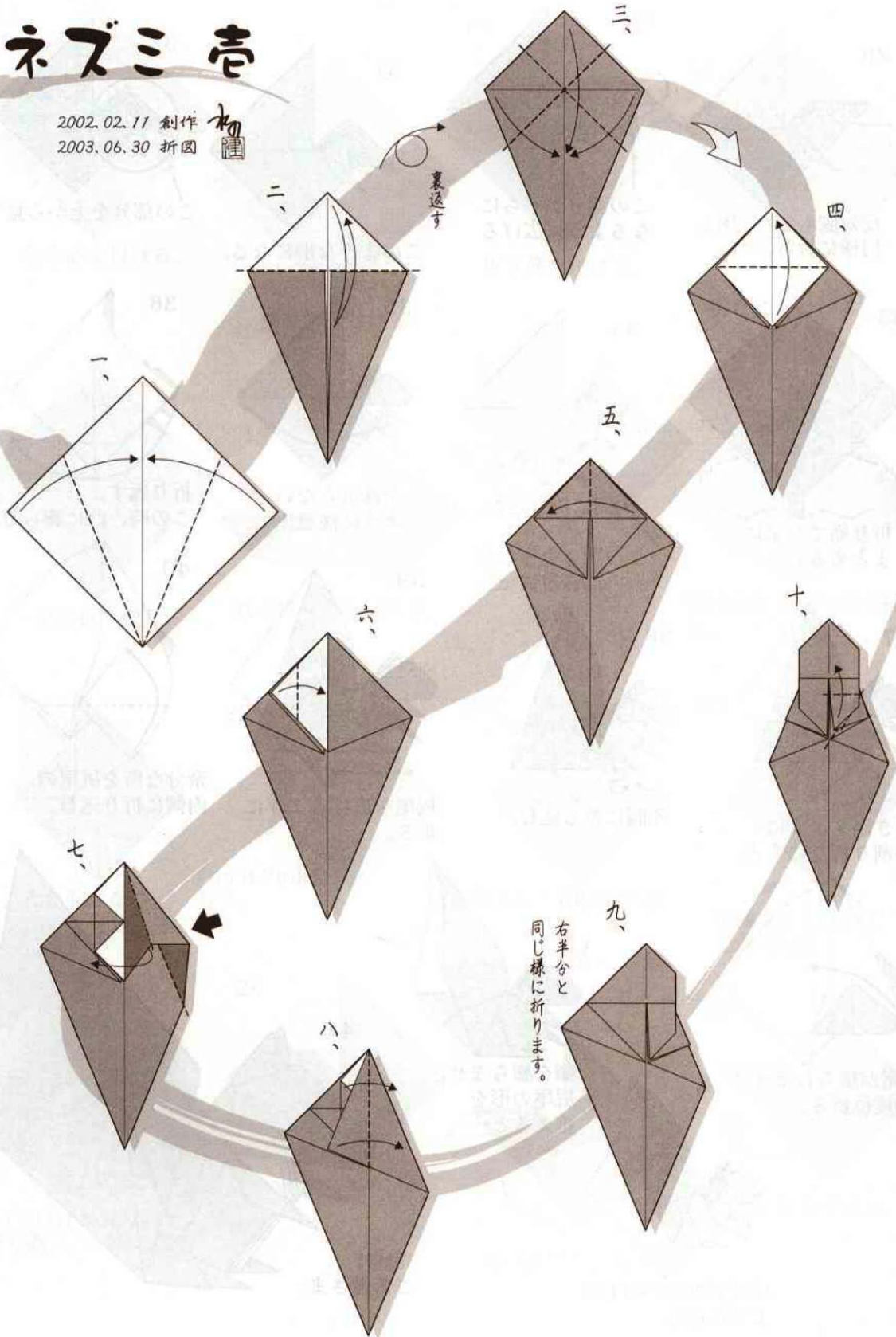

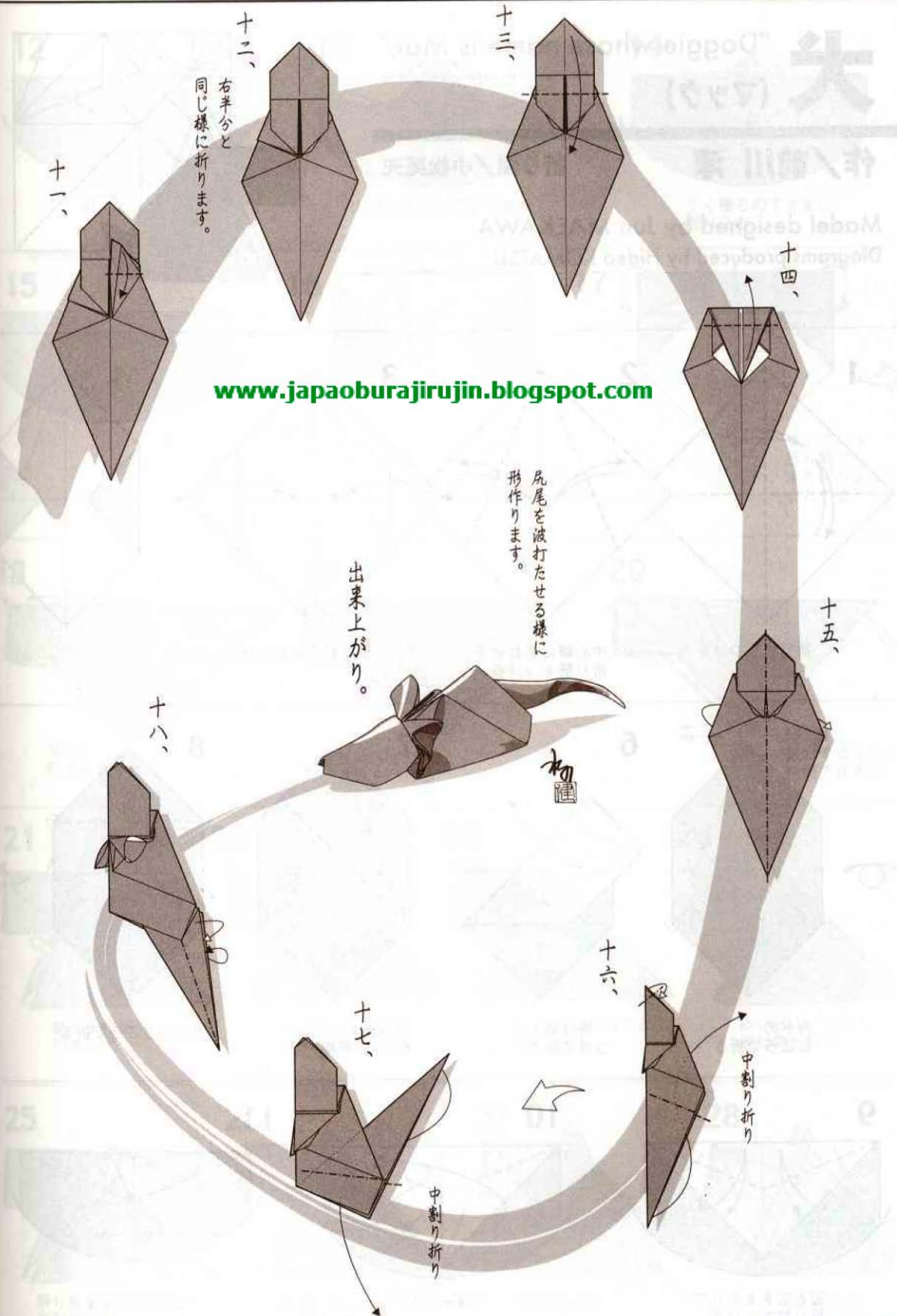

十二、  
右半分と  
同じ様に折ります。

十三、

十一、

十四、

[www.japaoburajirujin.blogspot.com](http://www.japaoburajirujin.blogspot.com)

尻尾を波打たせる様に  
形作ります。

出来上がり。

十五、

十八、

初陣

十六、

中割り折り

十七、

中割り折り

# 犬 "Doggie whose name is Mac" (マック)

作 / 前川 淳

折り図 / 小松英夫

Model designed by Jun MAEKAWA

Diagrams produced by Hideo KOMATSU

[www.japaoburajirujin.blogspot.com](http://www.japaoburajirujin.blogspot.com)

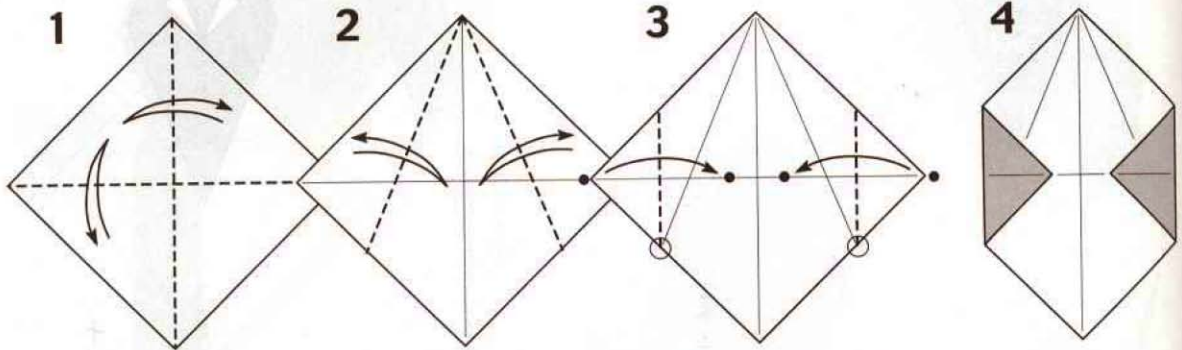
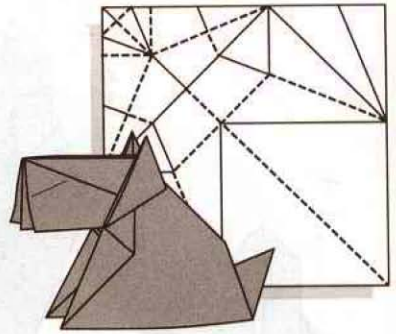

1 折り筋をつける

2 中心線にあわせて折り筋をつける

3 折り筋を目安に折る

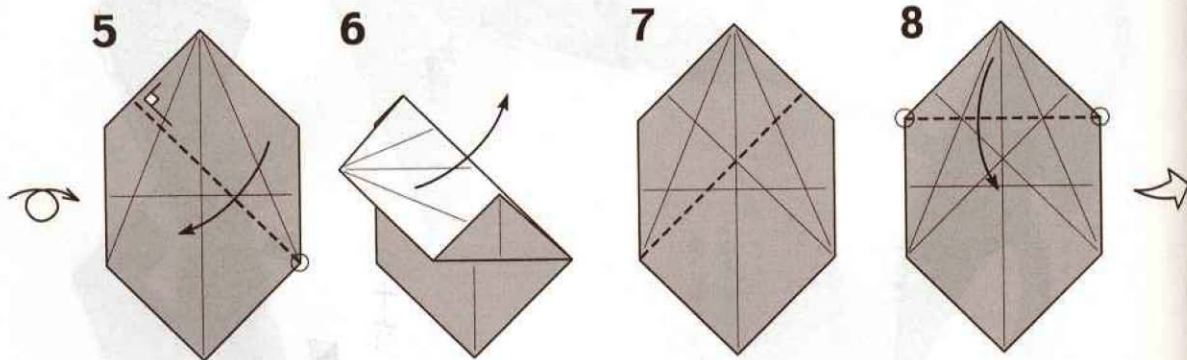

5 カドのところ  
で折る

6 折り筋を  
つけて戻す

7 反対側も  
5~6と同様

8 カドのところ  
で折る

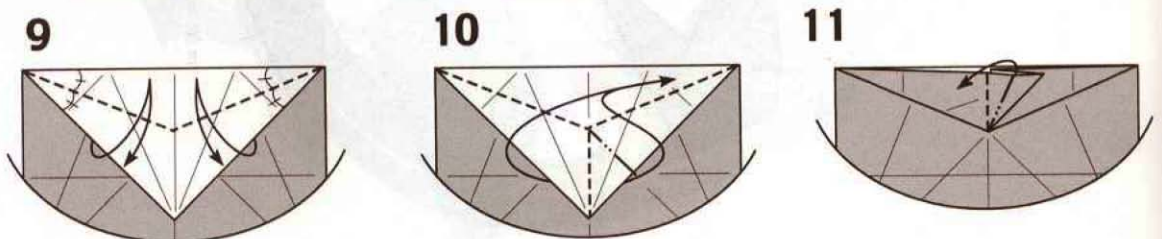

9 辺と辺をあわせて  
折り筋をつける

10 つまみ折り

11 広げてつぶす



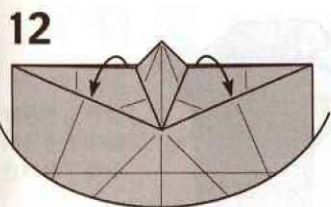

軽くひろげる

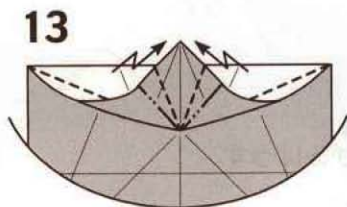

山谷を逆にして折り畳む



すぐ後ろのすきまに  
折り込む

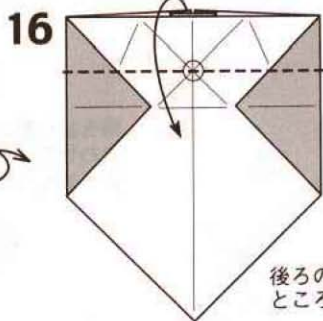
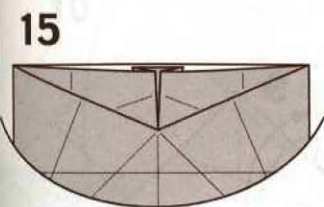

後ろのカドの  
ところで折る

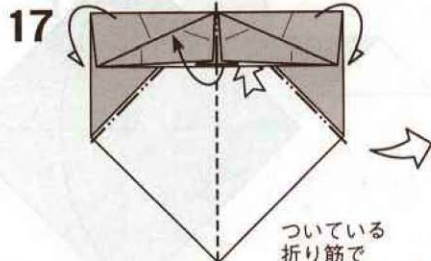

ついている  
折り筋で  
次の図のよう  
にまとめる

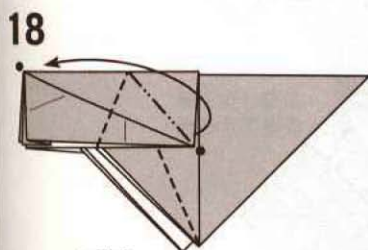

カドを  
引き寄せて折る

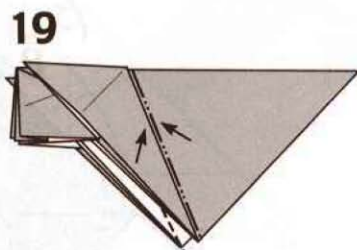

縁に沿って  
折り目をつける

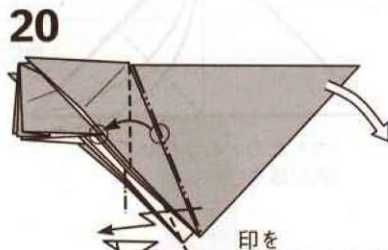

印を  
あわせるよう  
に  
両側で段折り

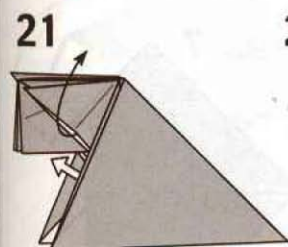

紙を1枚だけ  
引き出す

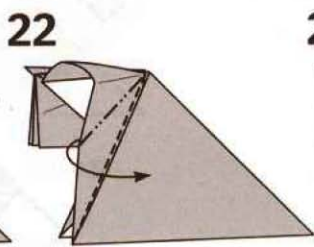

山谷を逆にして  
折り畳む

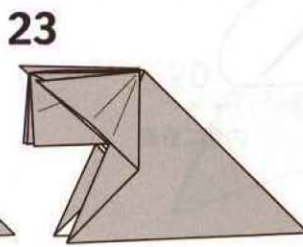

反対側も 21~22 と  
同様に折る

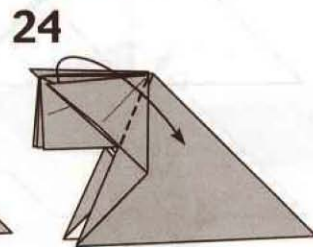

めいっばいに折る  
反対側も行う

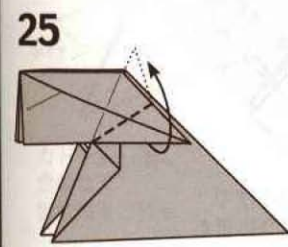

折り筋にあわせて折る  
反対側も行う

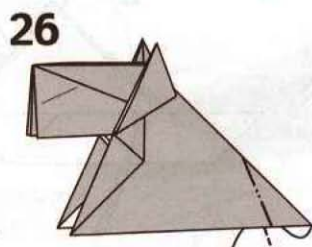

中割り折り

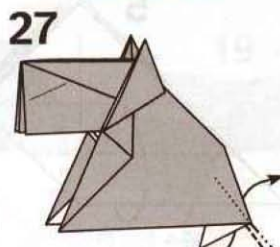

中割り折り

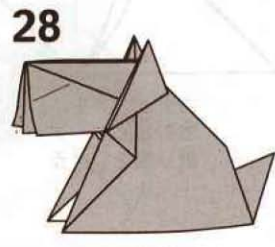

できあがり

# クマ

創作・西川誠司 折り図・おりがみはうす

Model Designed by Nishikawa Seiji  
Diagrams and Edited by ORIGAMIHOUSE

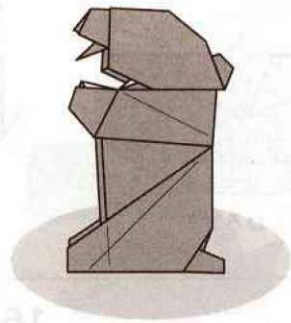

1

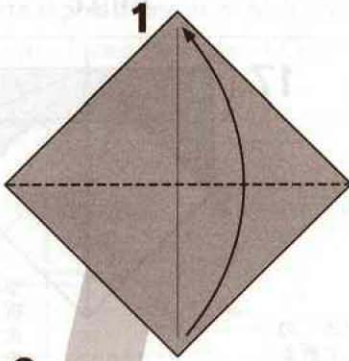

2

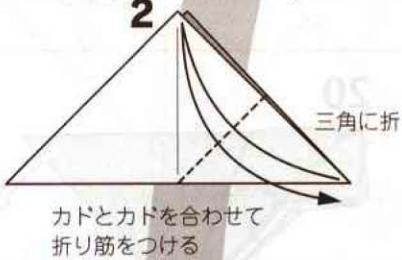

3

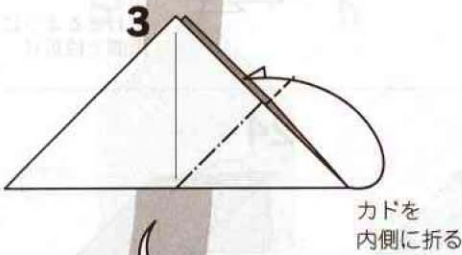

4

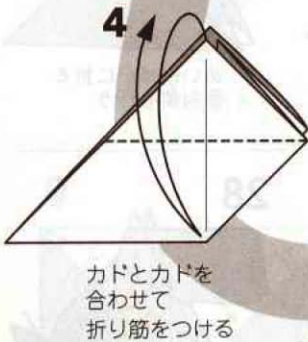

5

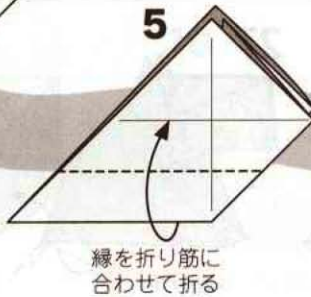

6

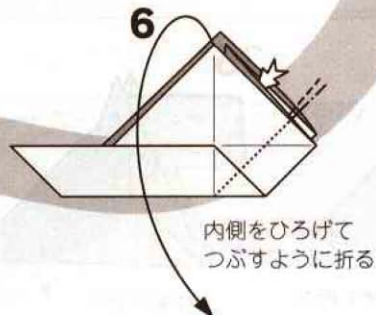

8

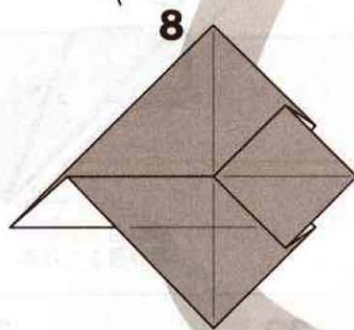

7

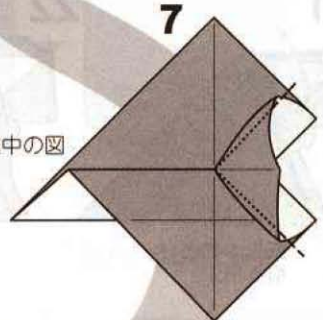

9

縁を折り筋に合わせて合わせて折り筋をつけ

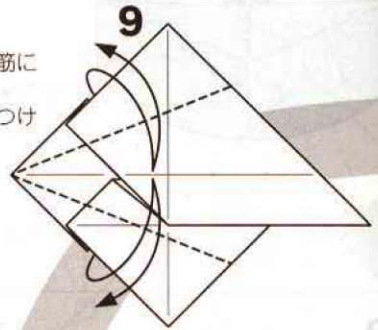

11

ずらすようにして  
カドを下の縁に  
合わせて折る

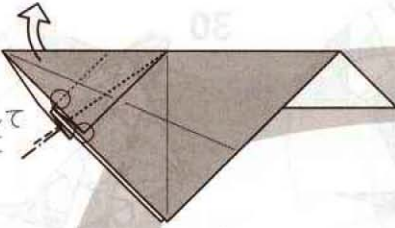

12

しっかりと  
折り筋を  
つけてから  
11の形に  
戻す

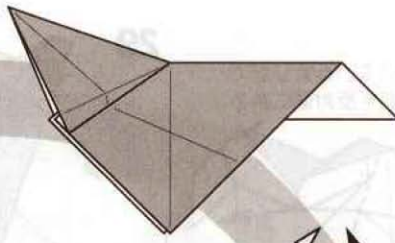

10

カドとカドを  
合わせて折る

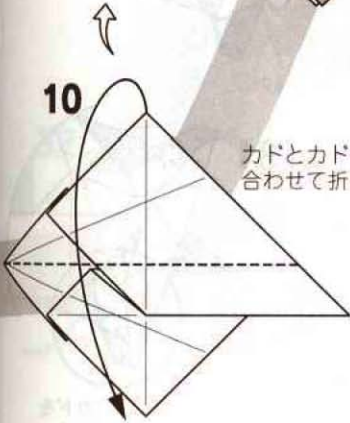

13

下のカドを  
後ろへ折って  
開く

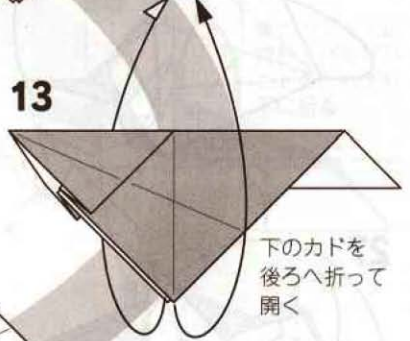

14

12でつけた  
折り筋で折る

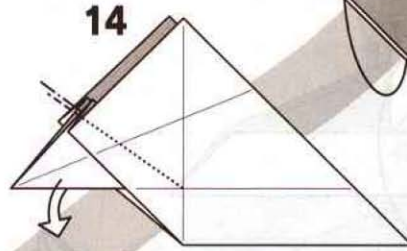

15

縁を折り筋に  
合わせて折る

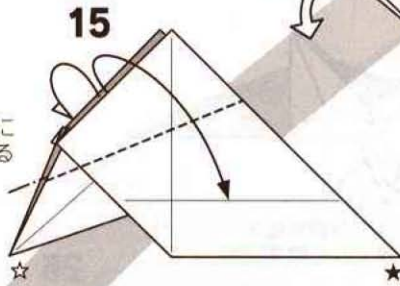

16

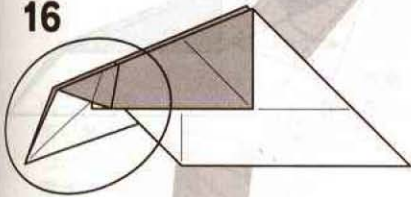

20

縁を折り筋に  
合わせて  
折り筋をつける

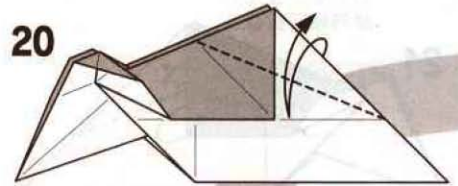

17

カドを折り筋に  
合わせて  
折り筋をつける

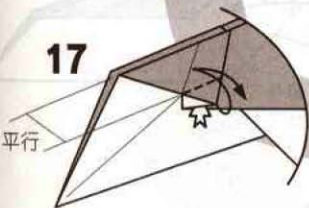

18

内側をひろげて  
つぶすように折る

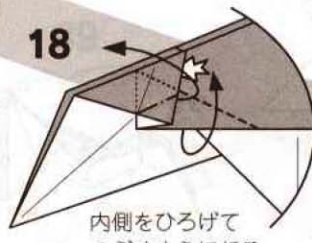

19

反対側も同じ

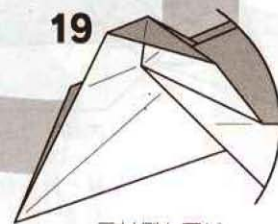

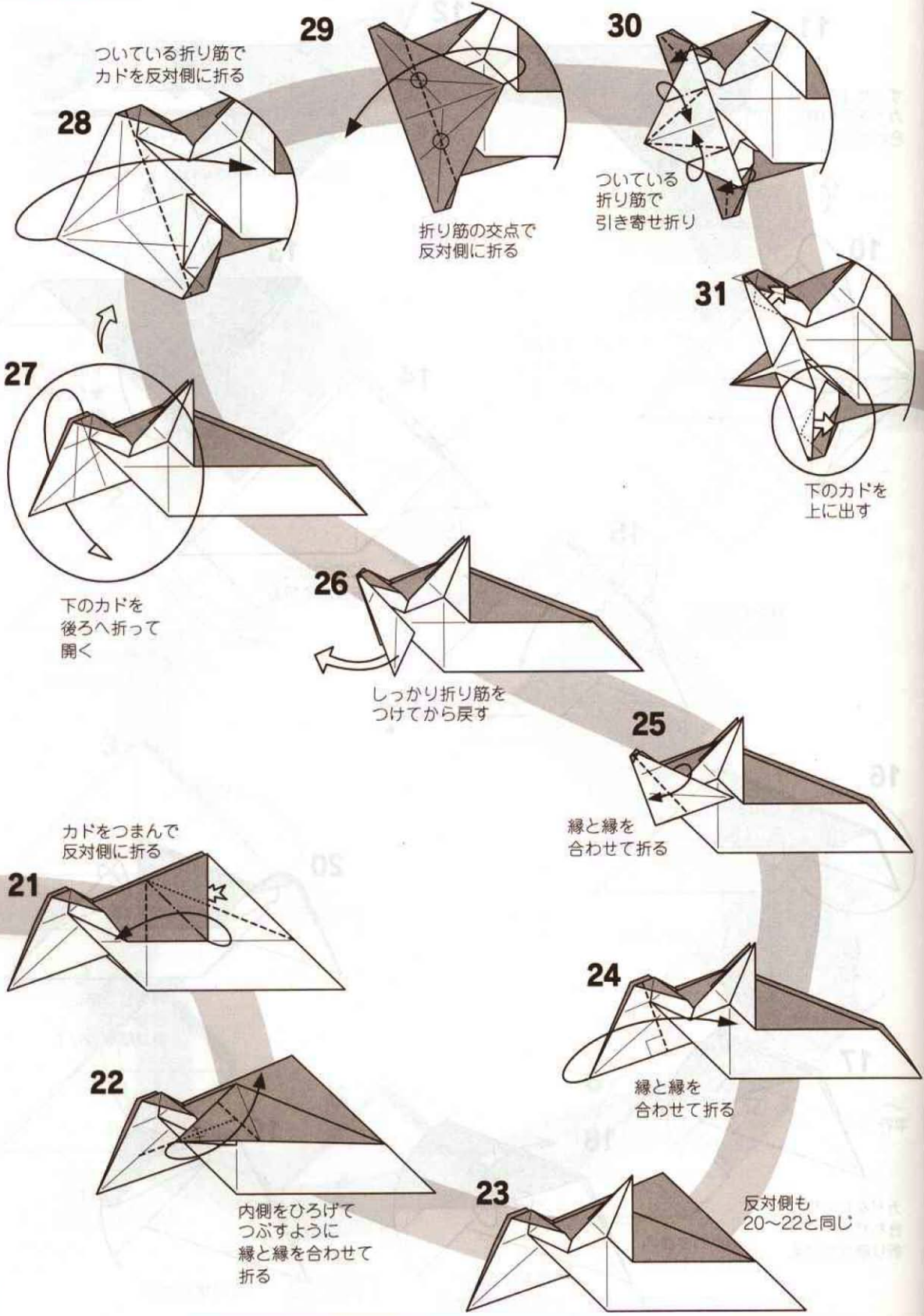

28 ついている折り筋で  
カドを反対側に折る

29

折り筋の交点で  
反対側に折る

30

ついている  
折り筋で  
引き寄せ折り

31

下のカドを  
上に出す

27

下のカドを  
後ろへ折って  
開く

26

しっかり折り筋を  
つけてから戻す

25

縁と縁を  
合わせて折る

21

カドをつまんで  
反対側に折る

24

縁と縁を  
合わせて折る

22

内側をひろげて  
つぶすように  
縁と縁を合わせて  
折る

23

反対側も  
20~22と同じ

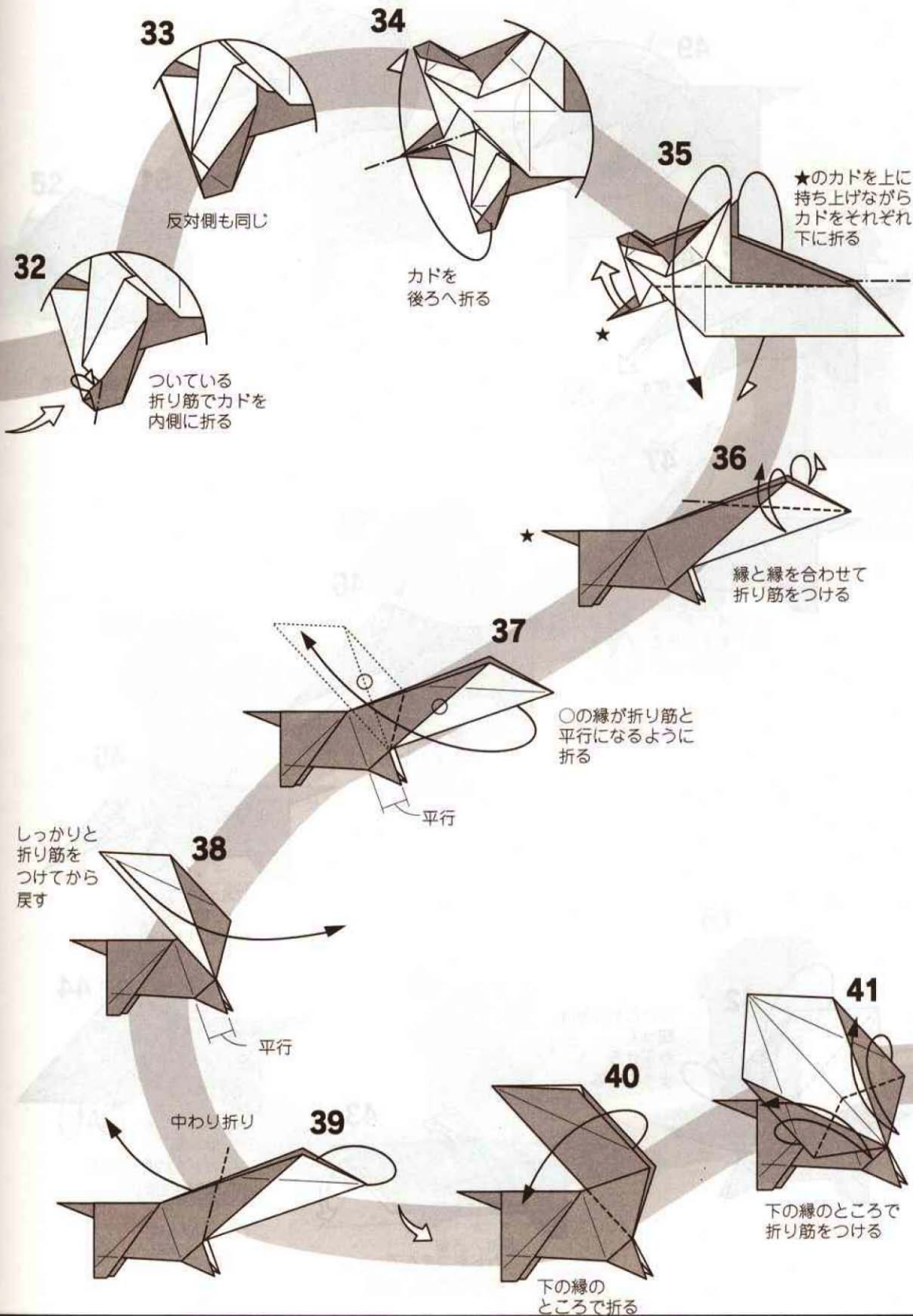

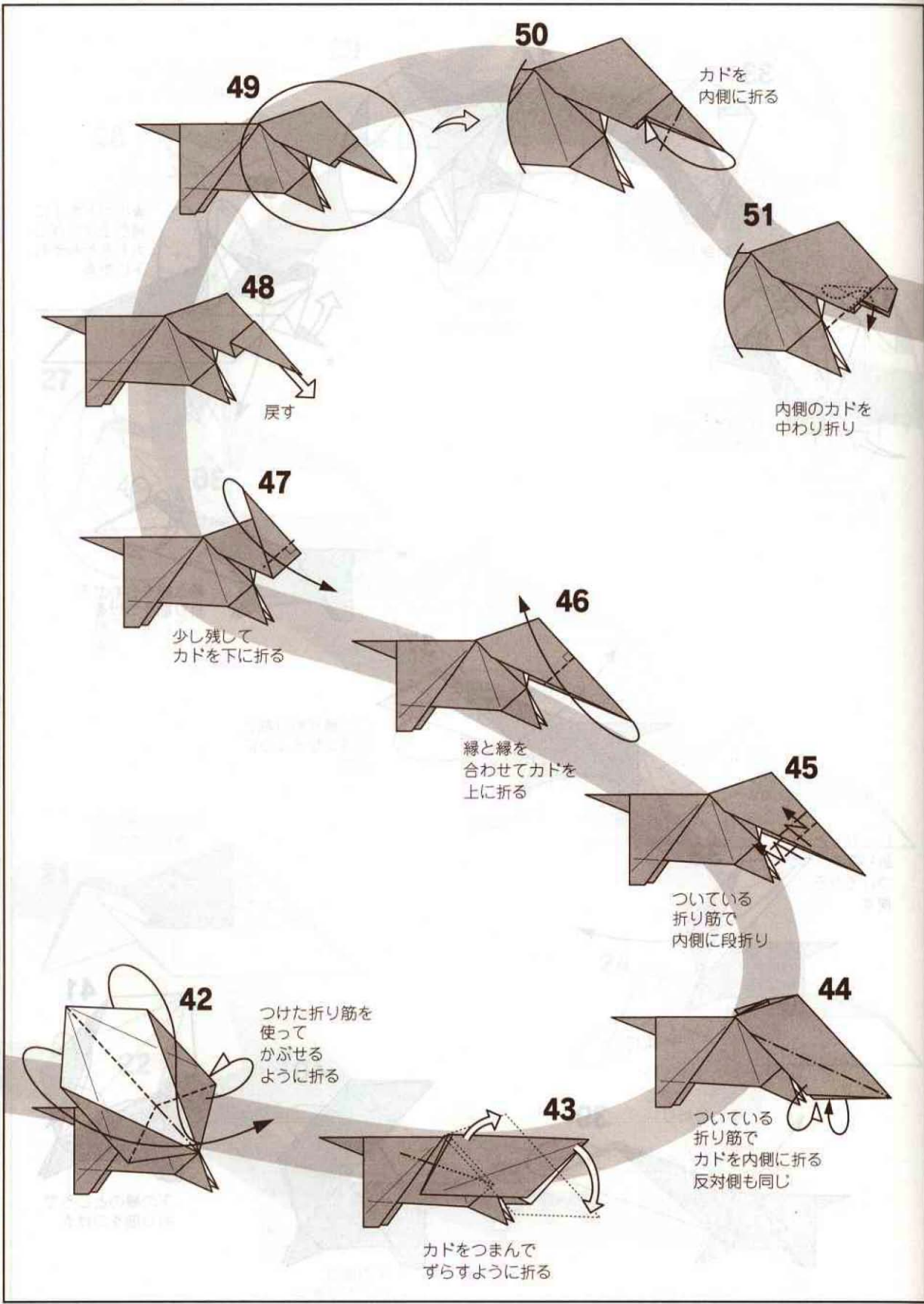



52



53

カドをつまんで  
重なりを  
戻す



54

斜めに  
段折り

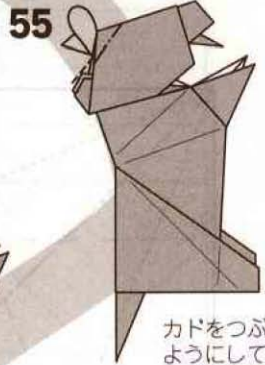

55

カドをつぶす  
ようにして  
内側に折る

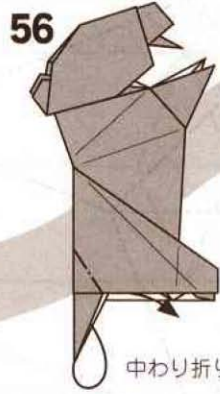

56

中わり折り

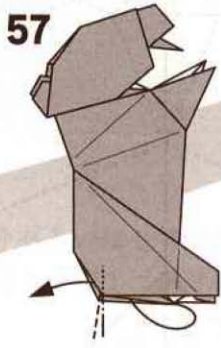

57

中わり折り

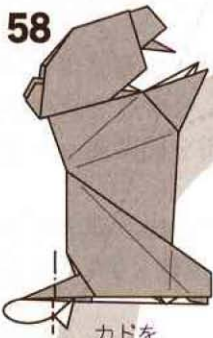

58

カドを  
内側に折る

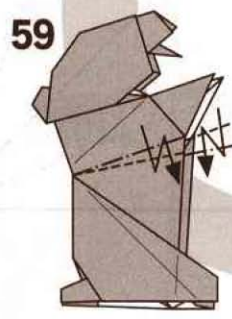

59

かぶせるように  
斜めに段折り



60

カドを  
後ろへ折る  
反対側も同じ

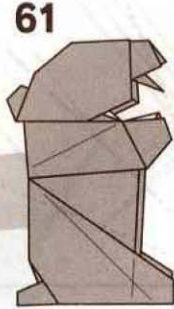

61

できあがり

[www.japaoburajirujin.blogspot.com](http://www.japaoburajirujin.blogspot.com)

# 日本猿

2003.4

前川淳

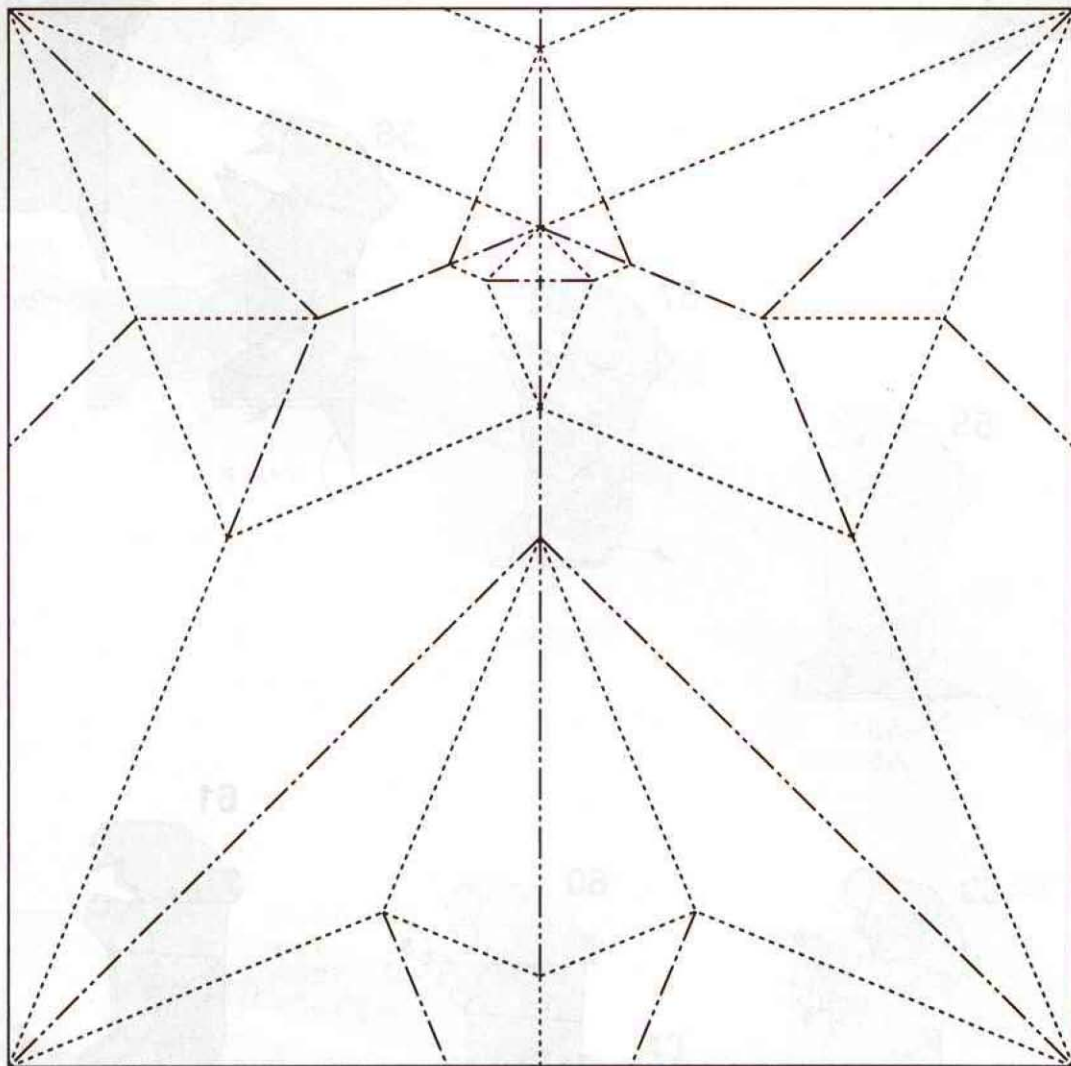
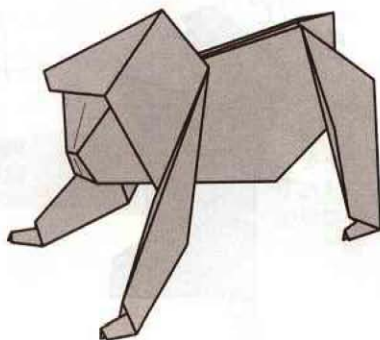

----- 谷線  
——— 山線

紙の裏から見た図です。



オランウータン ORANG-UTAN

創作 磯村 浩  
ISOMURA HIROSHI

写真はB4から切り出した用紙を使っていますが、もっと小さい紙でも大丈夫です。少し厚い紙の方が感じが出ると思います。表裏同色の紙で折って下さい。

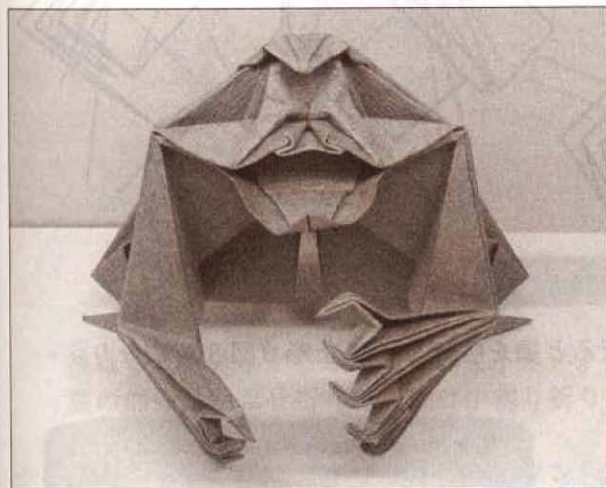

展開図

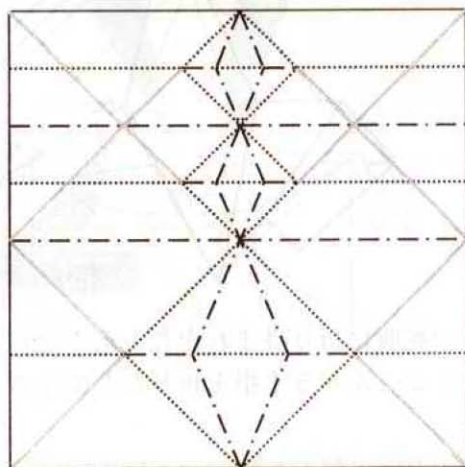

極めてシンプルな構造です。

どの線も辺や角を2等分、4等分あるいは8等分する線ですからグレーの線を基準に折って下さい。展開図を折りあげると図1（前・後）となります。

図1の基本形を取り出したら、まず下顎の部分を折り下げます。（図2参照）

これで両肩の位置が決まります。

次は臀部を折り下げて、足とお尻を中割り折りです同時に折り出します。



図1（前）



図1（後）

この部分を沈め折りして、顔を作ります。(図5参照)

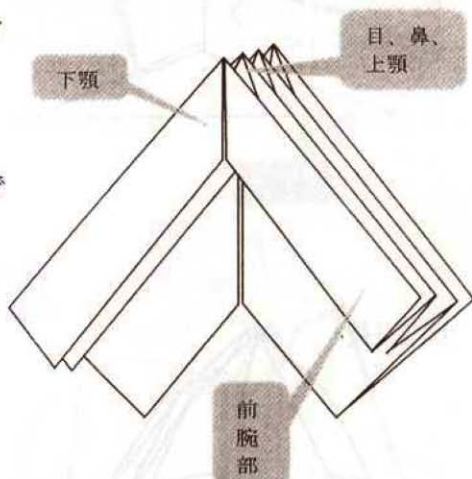
図2 (前)

肩

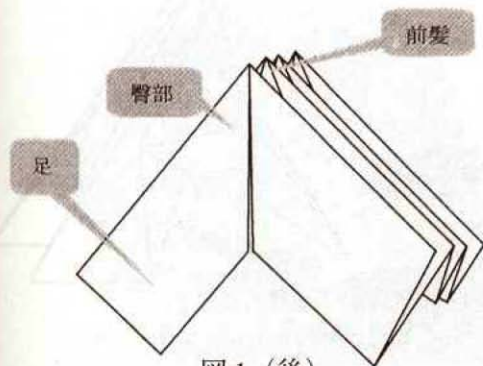
図2 (後)

中割折りしてできた足。

図2の蛇腹に折り畳まれた長方形を点線で折ると扇を広げたような形(図3)になります。ここから5本指を折りだして下さい。

図3 (肩から先だけの拡大図)

図3をグレーの線で折りたたむとこんな感じになります。肩の支点が離れているのは気にしないでください



図4 (前)

図4 (後)

右足

この線にあわせて中割折りを繰り返して指をつくる。

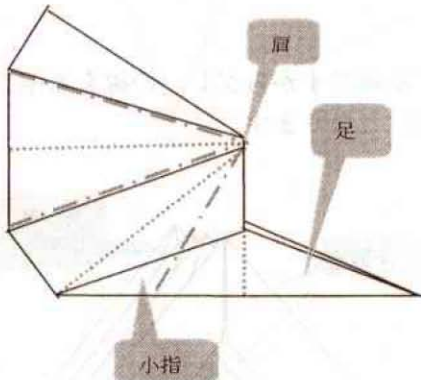

図5 (頭部拡大図)

後は写真を見ながら頑張ってみてください。

膝の部分はかぶせ折り、足先は中割り折りを2回です。

広島市立安佐動物公園のオランウータン「ジャック」をモデルにしましたが、ジャックは毛むくじゃらでいつも顔はよく見えませんでした。 ニンヤリと笑っているのだろうと勝手に思いこんで制作しました。 結局ゴリラなのかオランウータンなのか、はっきりしない動物になってしまいました。黒い紙で折ったときはゴリラ、赤茶色の紙で折ったときはオランウータンということにして楽しんでいきます。

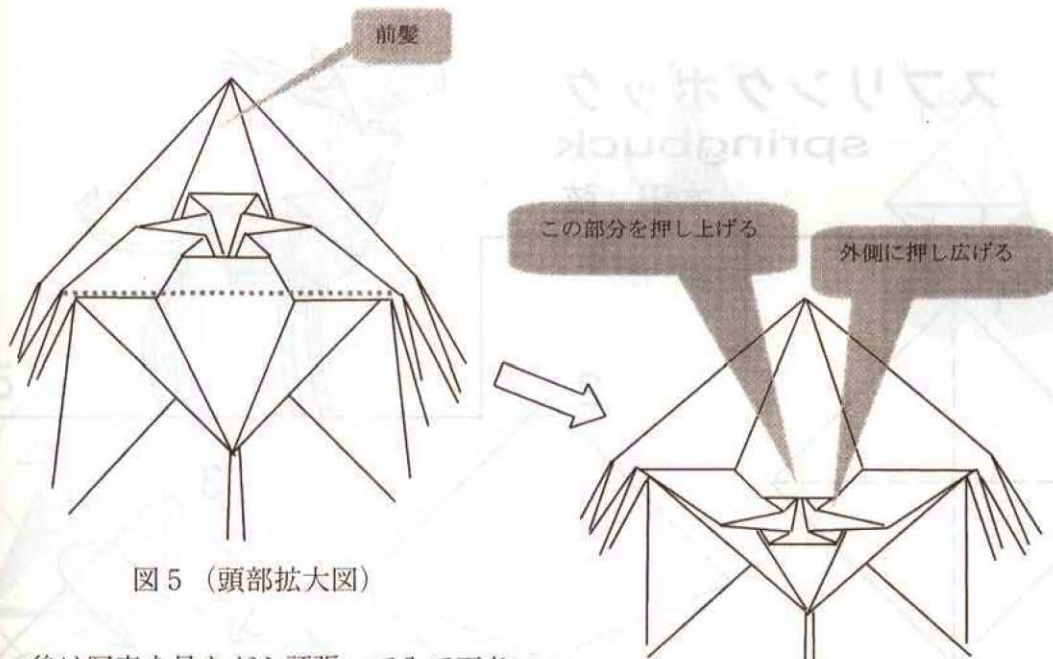
展開図の下半分の山谷を逆に折ると左下の写真のように腹部が割れてないオランウータンができます。折り方はほとんど同じです。腹割れバージョンに続けて折ってみてください。

こちらの方がオランウータンらしいと思いますが、今度は背中が割れてしまいます。

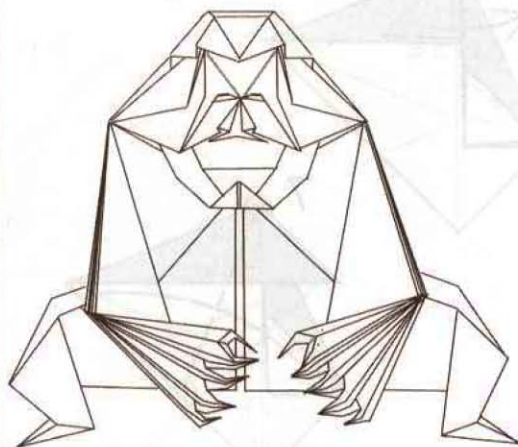
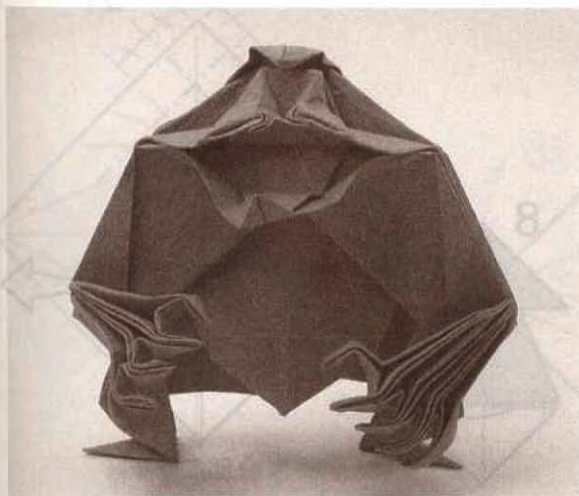

# スプリングボック springbuck

本田 弦

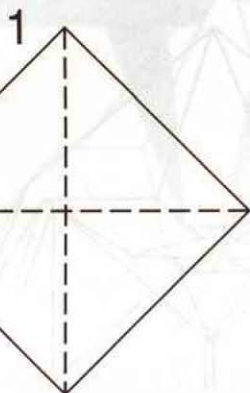

折り筋をつける

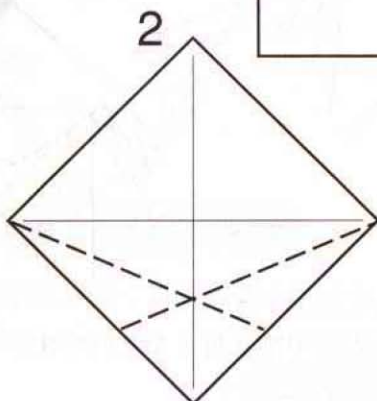

折り筋をつける

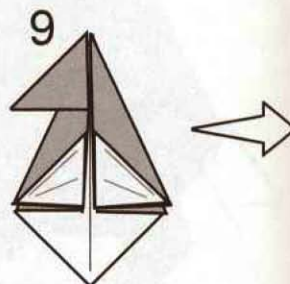
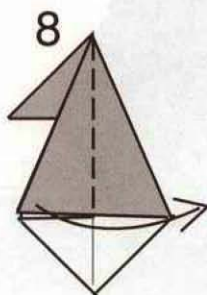
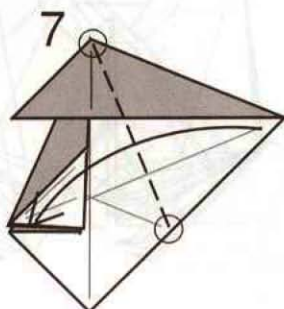
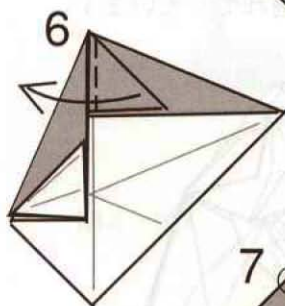
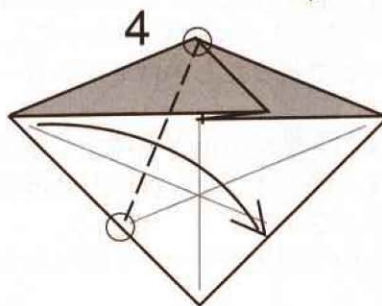
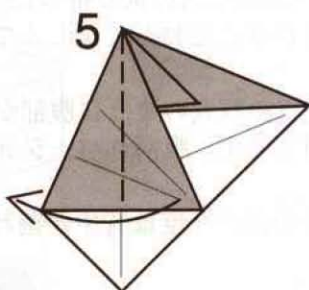
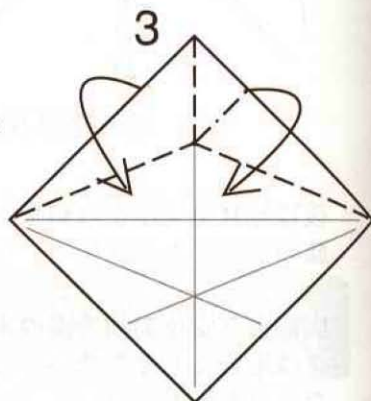

全部広げる

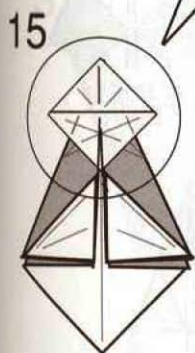

15

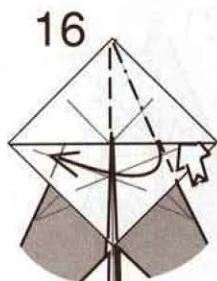

16

広げてつぶす

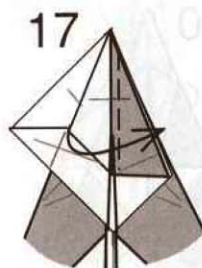

17

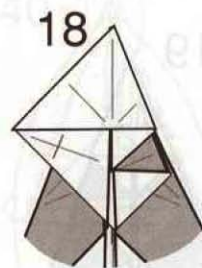

18

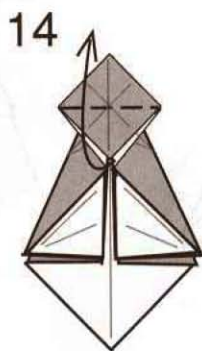

14

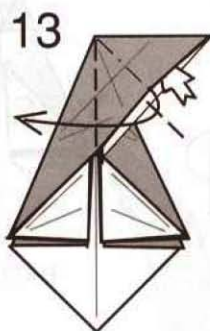

13

広げてつぶす

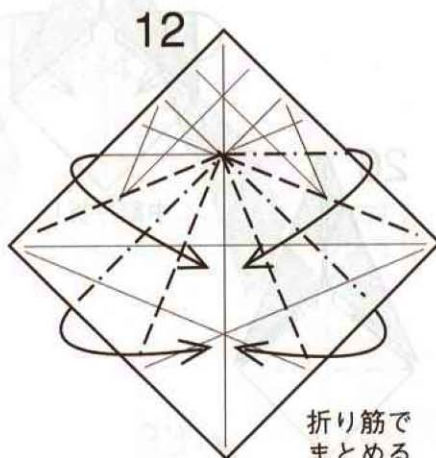

12

折り筋で  
まとめる

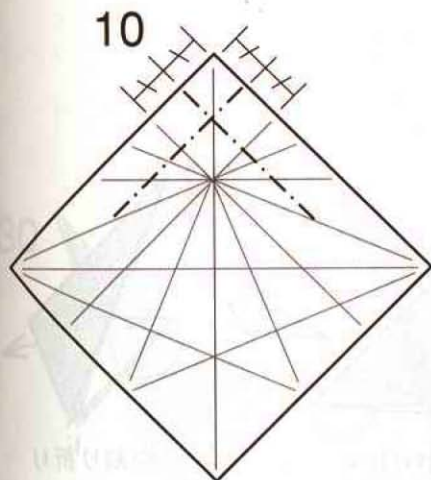

10

折り筋をつける

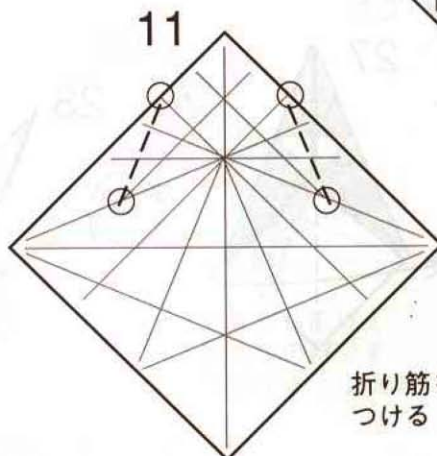

11

折り筋を  
つける

19

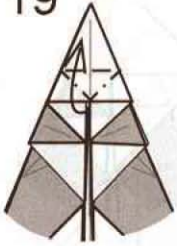

花弁折り

20

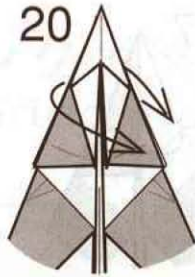

重なっている紙を広げる

21

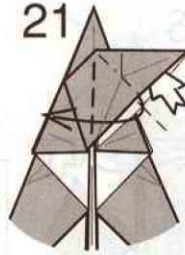

22

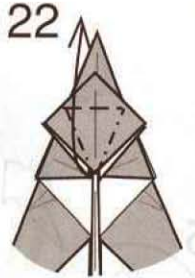

花弁折り

25

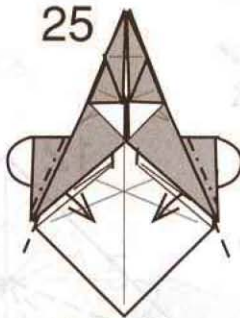

中割り折り

24

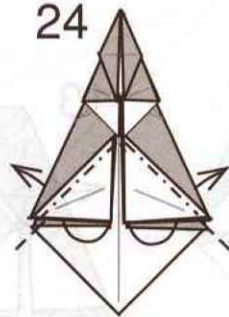

中割り折り

23

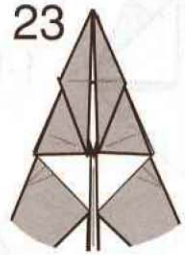

26

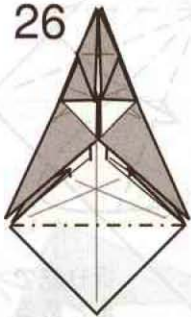

折り筋をつける

27

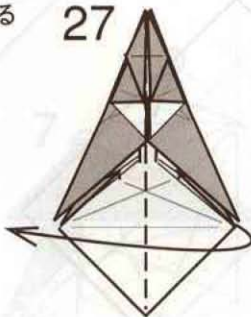

28

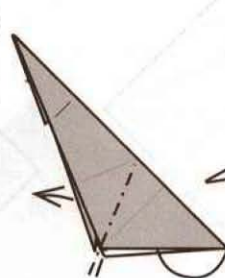

中割り折り

29

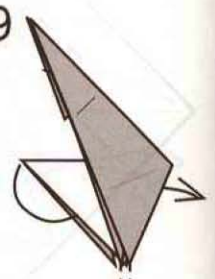

中割り折り

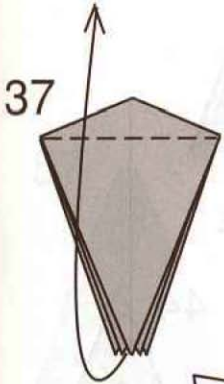

37

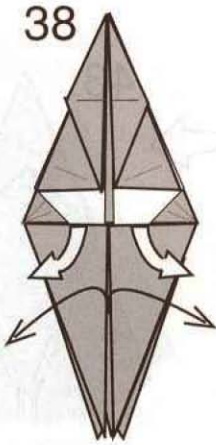

38

内側の紙を  
引き出す

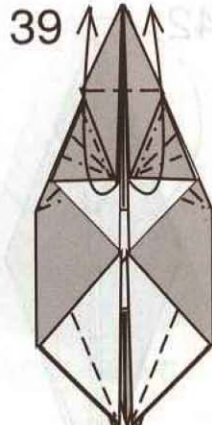

39

折り筋を使って  
かどを引き上げる

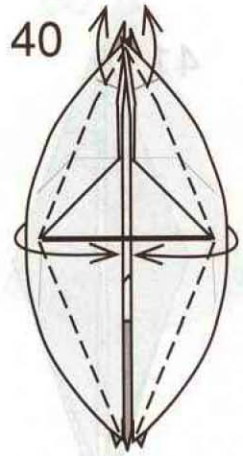

40

途中図



36

広げてつぶす

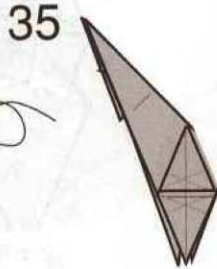

35

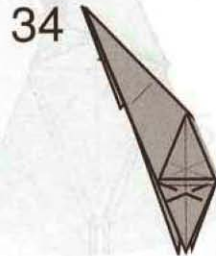

34

折り筋を  
つける

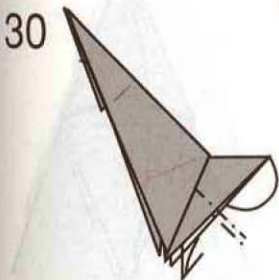

30

中割り折り

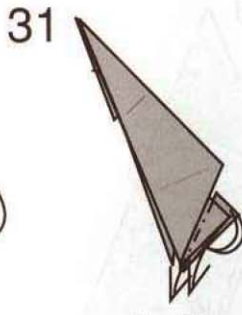

31

2ヶ所  
中割り折り

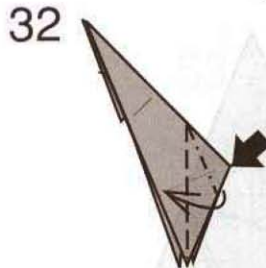

32

中央から広げて  
黒矢印の部分を  
つぶすように折る

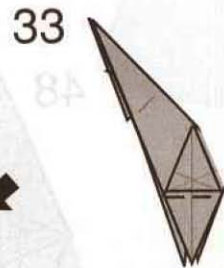

33

折り筋を  
つける

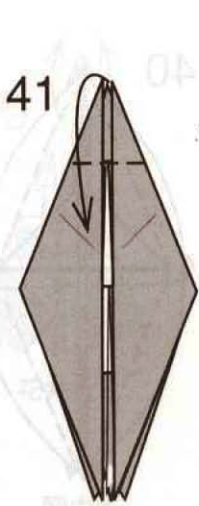

かどを3つ  
折り下げる

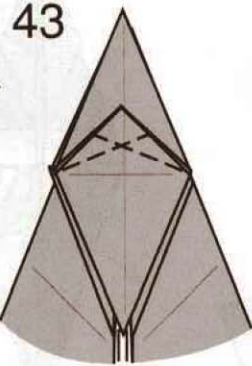
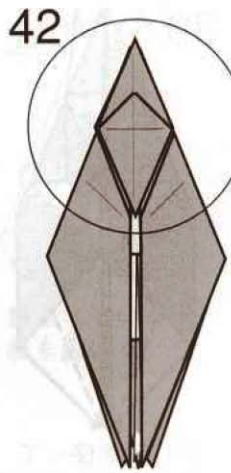

折り筋をつける

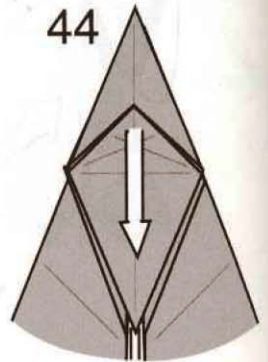

三角の部分を広げる

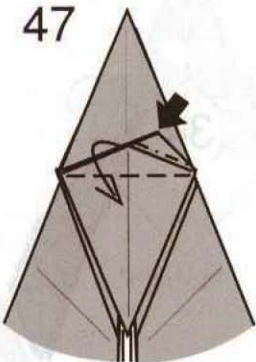

一番手前にある層を  
広げて黒矢印の部分  
つぶすように折る

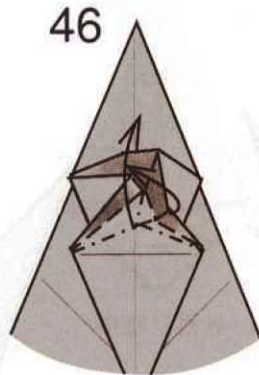

途中図

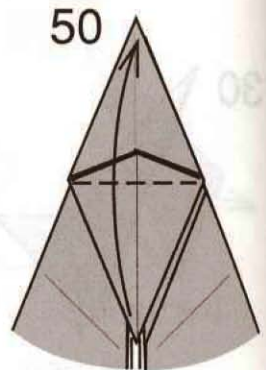
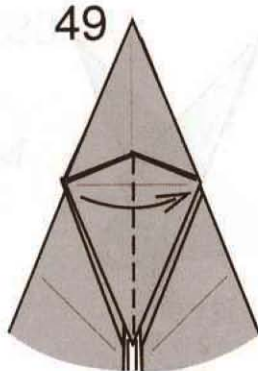
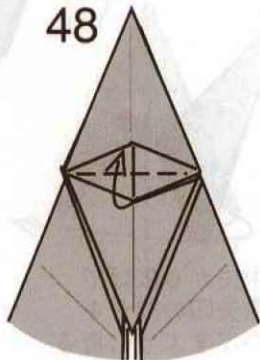



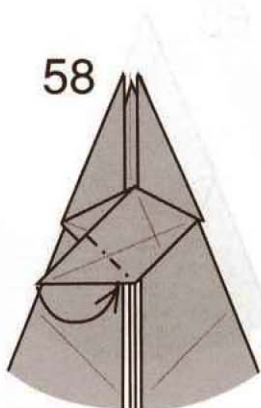

内側に折り込む

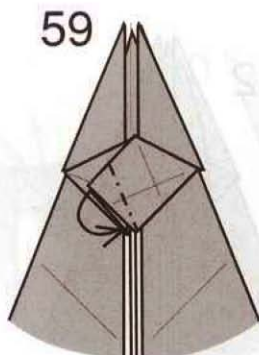

内側に折り込む

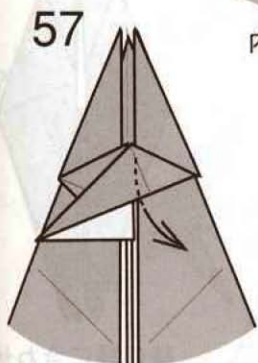
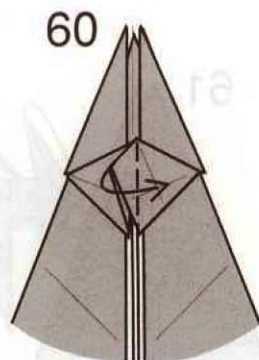

内側の紙を引き出す

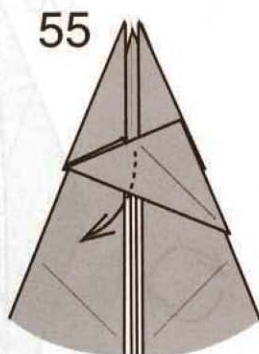
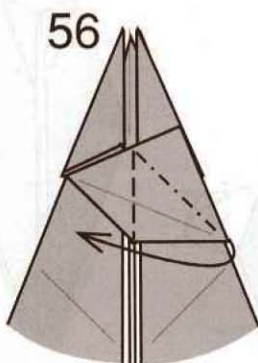

内側の紙を引き出す

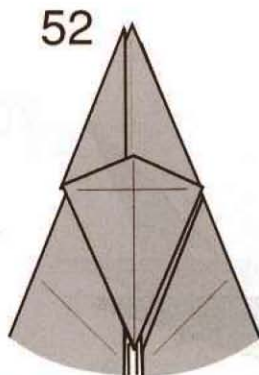
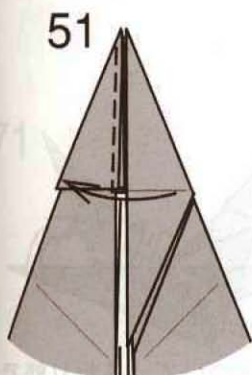
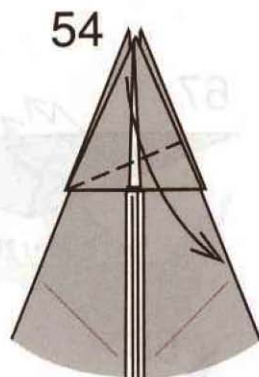

右側も 49～51と同じ

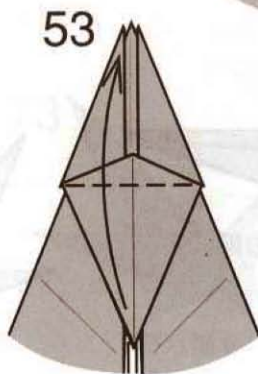

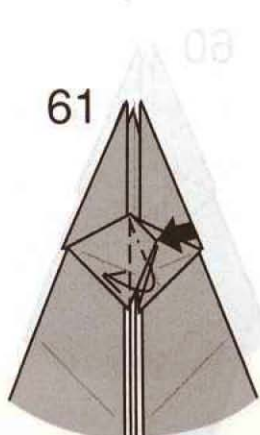

61

広げて黒矢印の部分  
をつぶすように折る

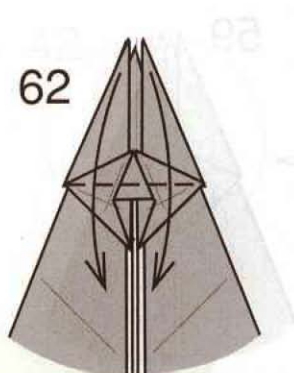

62

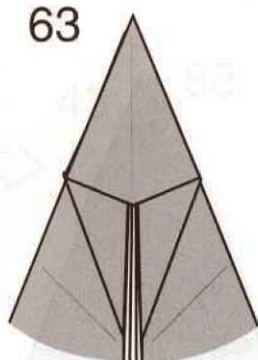

63

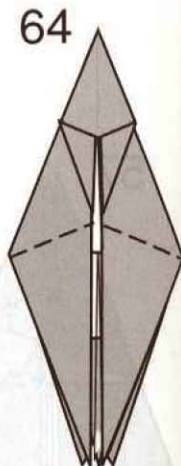

64

後の縁に合わせて  
折り筋をつける

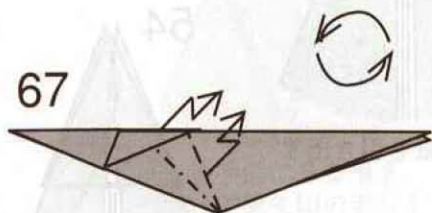

67

つけた折り筋で段折り

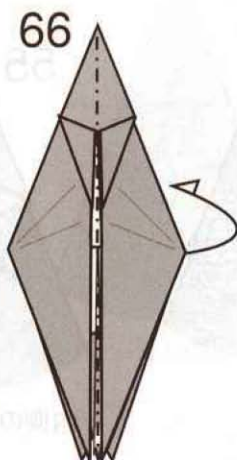

66

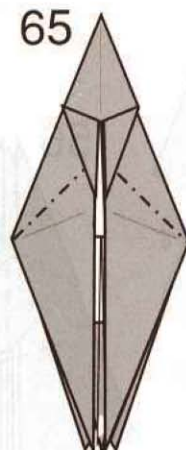

65

折り筋をつける

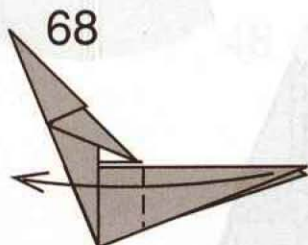

68

向こう側も同じ

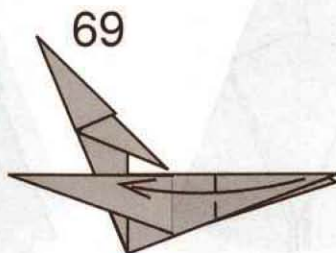

69

向こう側も同じ

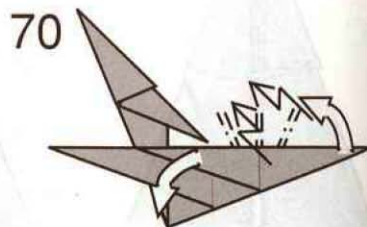

70

内側をついている折り筋で  
段に折りながら回転させる

78

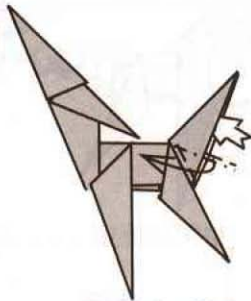

広げてつぶす

79

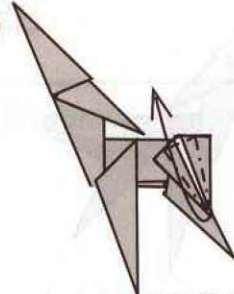

花弁折り

80

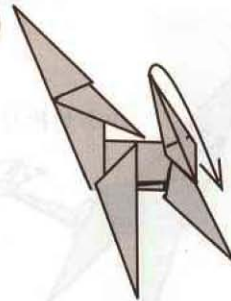

81

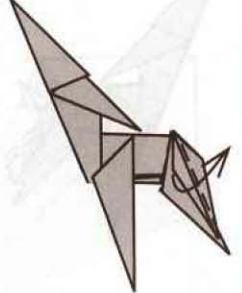

77

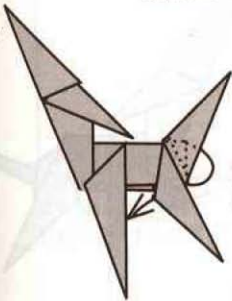

内側の2層を  
中割折り

76



向こう側も同じ

75

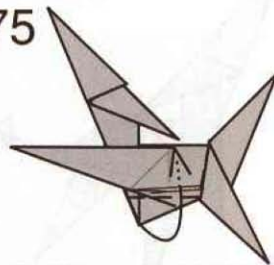

折り込んだところに  
向こう側の紙を差し込む

74



つけた折り筋で  
穴に折り込む

71

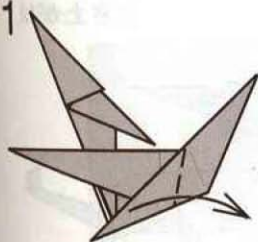

向こう側も同じ

72

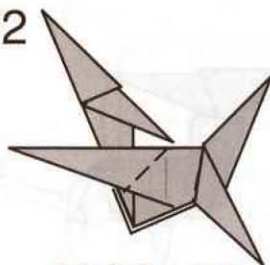

折り筋をつける  
向こう側も同じ

73



折り筋を  
つける

83

かぶせ折り



84

内側の紙を引き出す  
向こう側も同じ

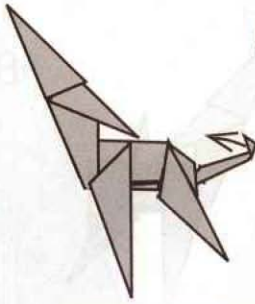

85

中割り折り

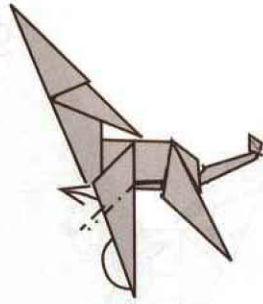

82

中割り折り

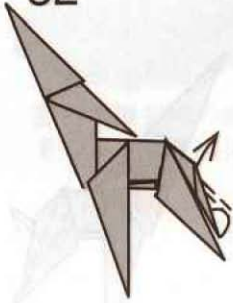

86

内側に折り込む  
裏側も同じ

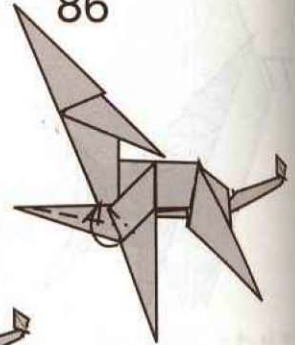

87

中割り折り



88

中割り折り

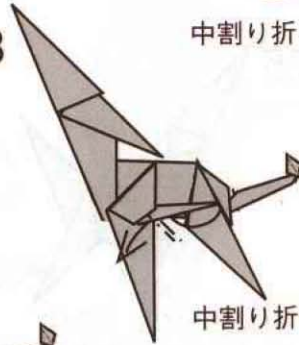

89

残り3ヶ所も  
84~87と  
同じ



93

でき上がり



90

段折り

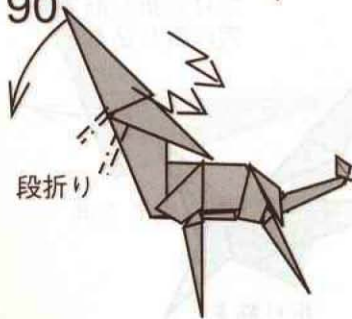

91

内側に  
折り込む

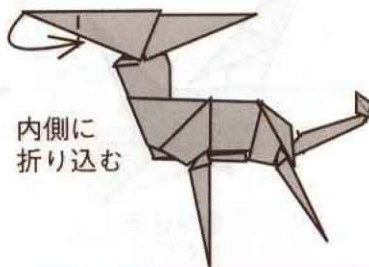

92

形を整える

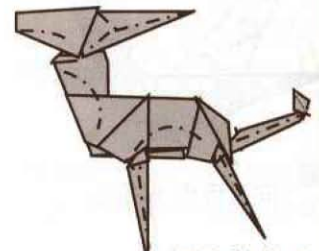

# ペリカン

**Pelican** 芦村俊一 / Ashimura Shun'ichi

[www.japaoburajirujin.blogspot.com](http://www.japaoburajirujin.blogspot.com)

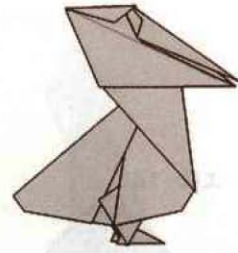

工程-1

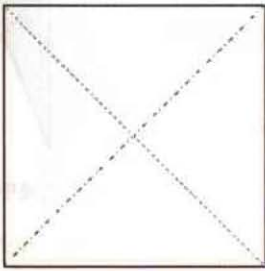

対角線に山・谷折で折線をつけておきます

工程-2

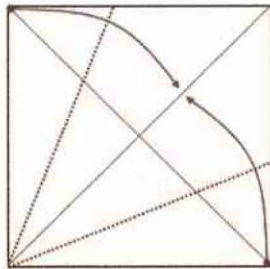

工程-3

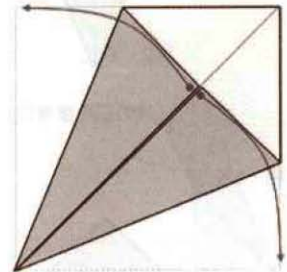

戻します

工程-5

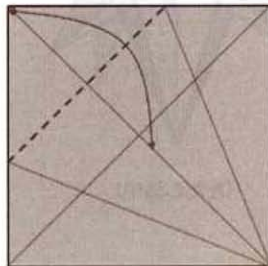

工程-4

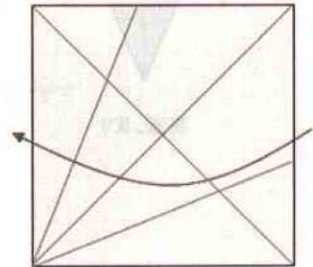

裏返します

工程-6

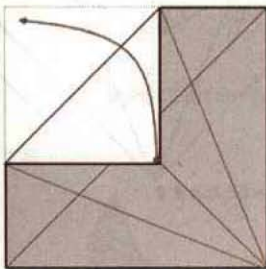

戻します

工程-7

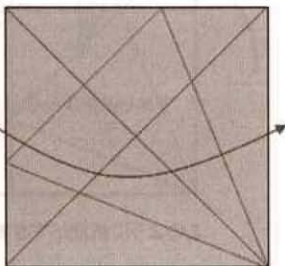

裏返します

工程-8

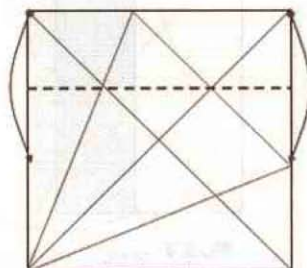

工程-9

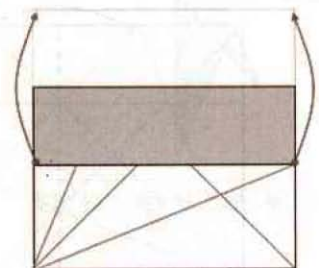

戻します

工程-16

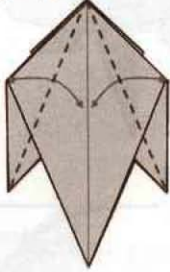

(次の図を参考に)

工程-17

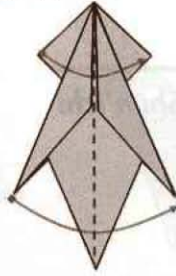

全体を半分に折ります

工程-18

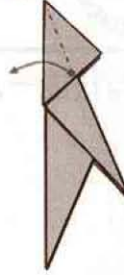

手前の袋を広げてたたみます

工程-19



(たたむ途中)

工程-15

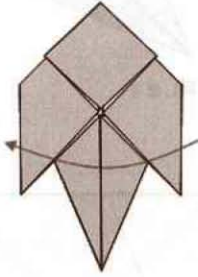

裏返します

工程-14

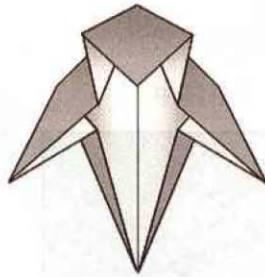

(たたむ途中)

工程-13

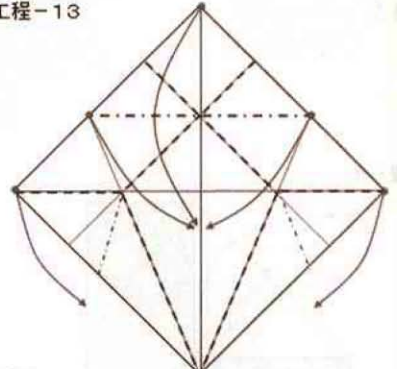

折り筋に従ってたたみます

工程-10

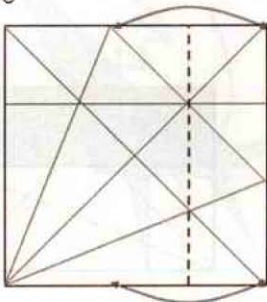

工程-11

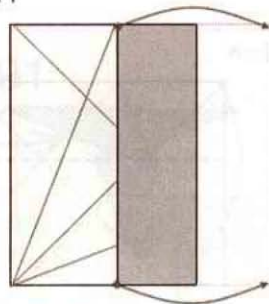

戻します

工程-12

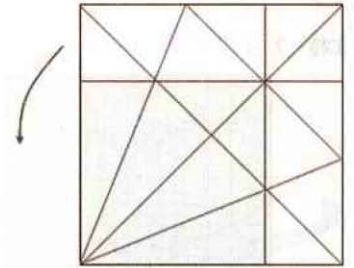

このように折筋ができます

工程-20

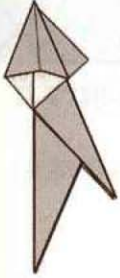

(たたむ途中)

工程-21



工程-22

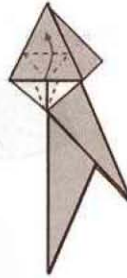

「カエル」の基本形の要領です

工程-23

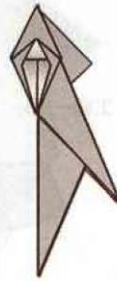

(途中)

工程-24

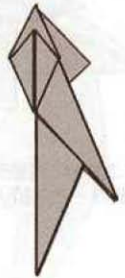

工程-25



角を下に下げます

工程-26



工程-27



裏側も工程18~26と同様に。

工程-28



手前の一枚を折ります

工程-29

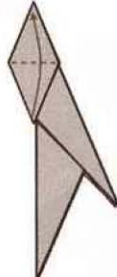

手前の角を折り上げます

工程-30

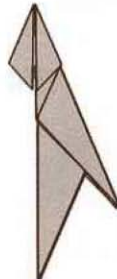

工程-31

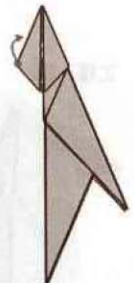

図で示した角を向こう側へ折ります

工程-41

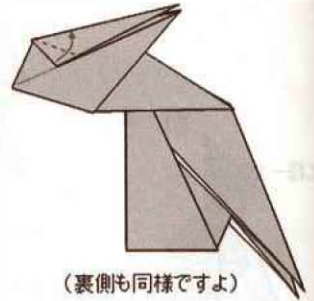

(裏側も同様ですよ)

工程-40

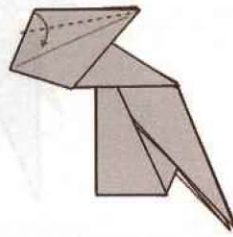

(裏側も同様です)

工程-39

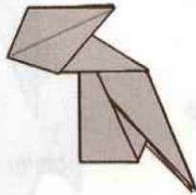

工程-38

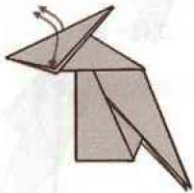

(ここからは裏側も同様に進めます)  
手前の一枚を折り上げます

工程-37

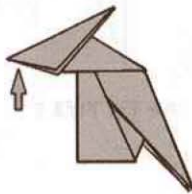

..すると内側の角も出てきます。

工程-36

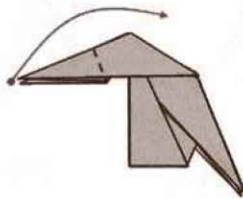

工程34の補助線で かぶせ折で

工程-35

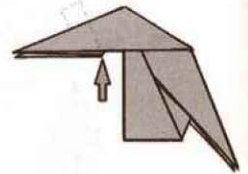

補助線と矢印に注目

工程-32

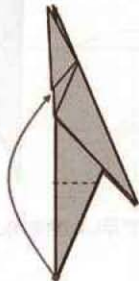

大きくかぶせ折

工程-33



工程-34

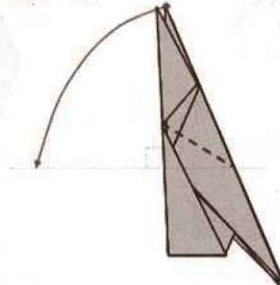

折の支点と角度に注意して、  
かぶせ折です



工程-43

工程-42

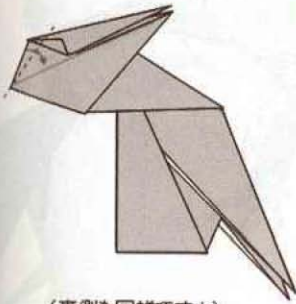

(裏側も同様ですよ)

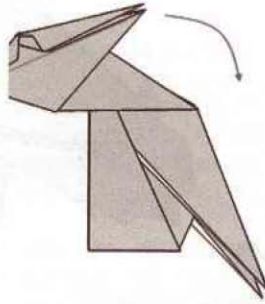

工程-44

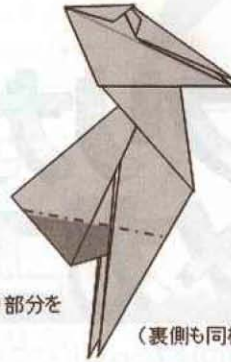

ピンクの部分を  
内側に

(裏側も同様ですよ)

工程-45

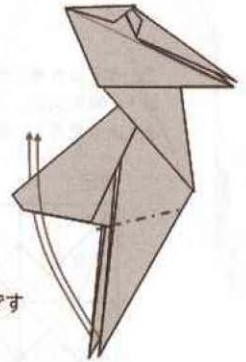

中割折です

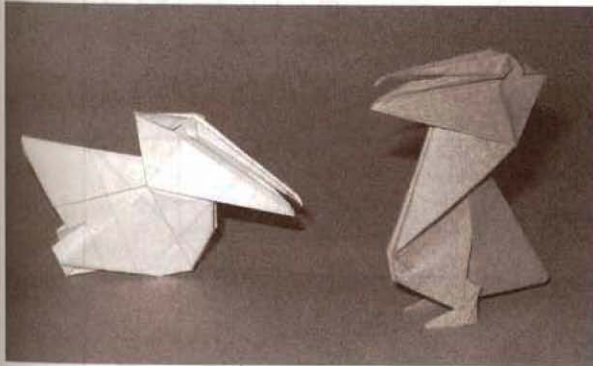

工程-46

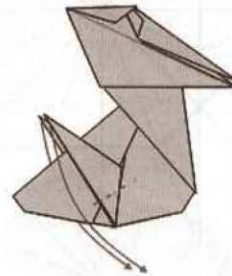

中割折です

工程-49

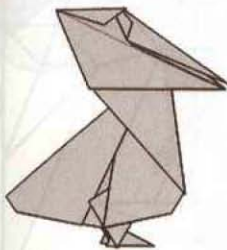

工程-48

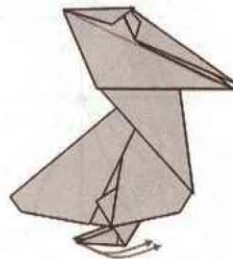

中割折です

工程-47

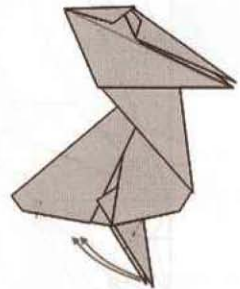

中割折です

立つように足の折りを微調整して完成です。  
お疲れさまでした。

# アフリカツメガエル

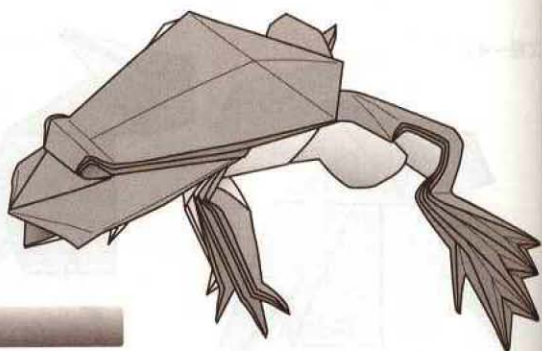

"Xenopus borealis" ©HOJYO Takashi 2003

創作・図 北條高史

創作：2003/05/25

作図：2003/07/05

この作品は表裏の色が異なる用紙を用いると、背側と腹側を色分けした完成形にすることができます。  
 以下の展開図は、用紙の裏側（作品の腹側の色になるほう）から見たもので、点線が谷折り、実線が山折りとなります。  
 よくよく見ると…基本的な比率は拙作「人物の基本形」と同じです。

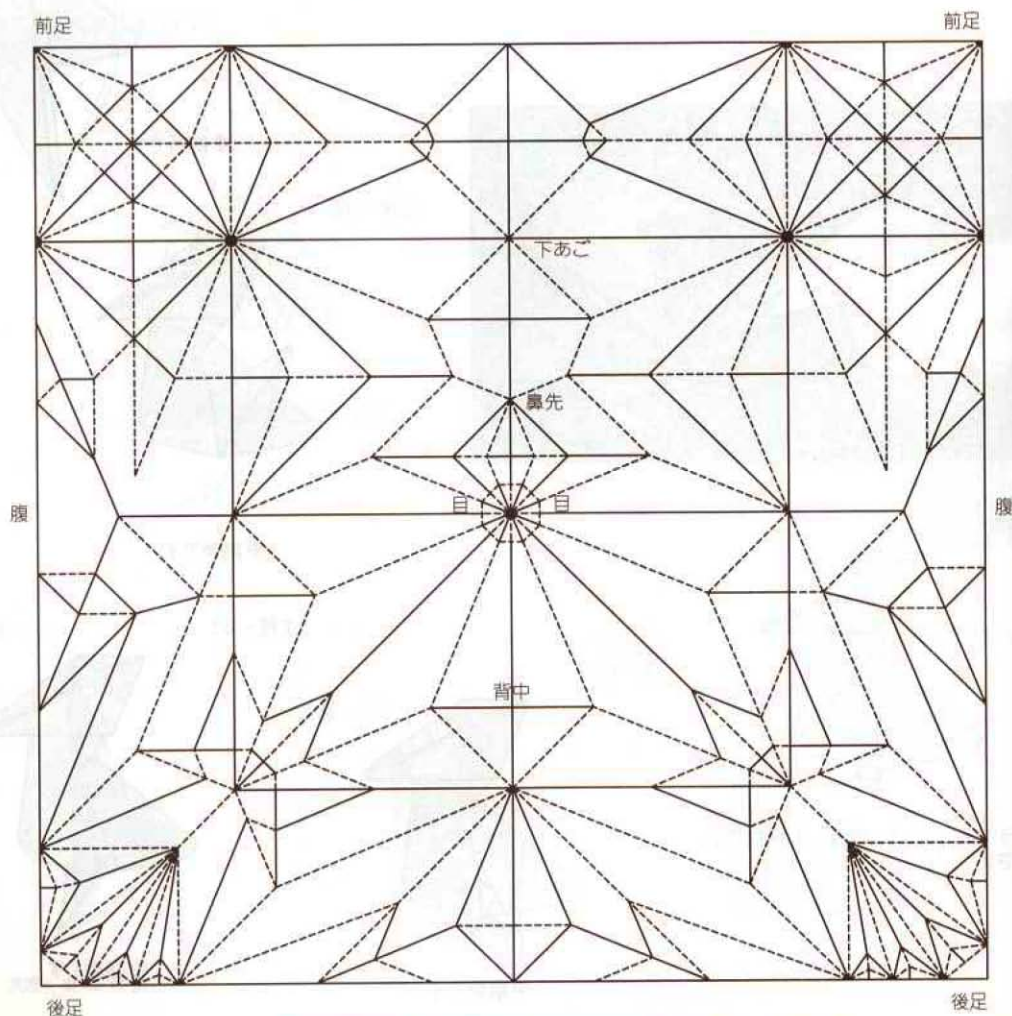

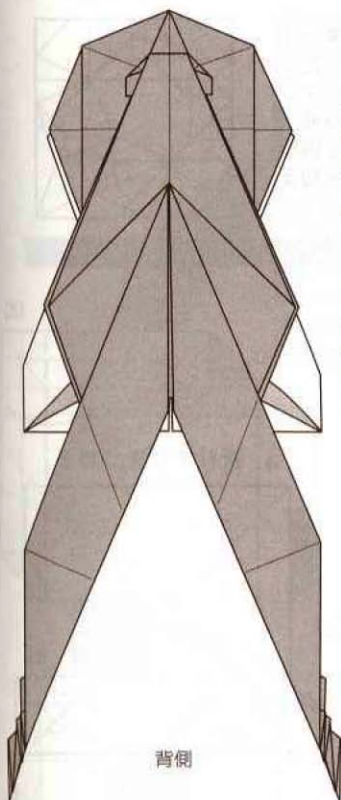

背側

前足の展開図通りに折ると、左右の図のようになります。腹の一部は平面的にぴったりとは折れず、立体的に少し湾曲したような状態になります。ここまでできたら、右の腹側の図にある折り線で頭部を細くし、下の完成図を参考にしてポーズを付けましょう。目の部分は、筒のように巻いて表現します。

前足の指は、腕の根元まで裂けた状態になっています。適度な長さを残して糊付けしてしまうのが簡単ですが、指の間の用紙を引き出し、隙間に差し込むことによって腕全体の開き止めを行い、同時に指の長さを調節するという方法も可能です。

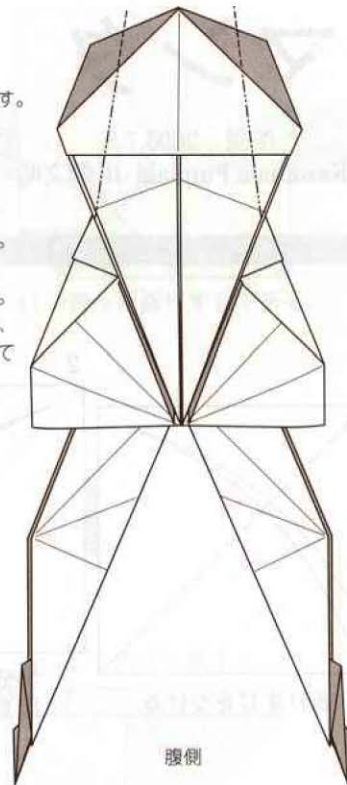

腹側

本作の題材である「アフリカツメガエル」は、筆者が大学院時代に研究対象として扱っていた実験動物です。一般的によく見かけるのは *Xenopus laevis* ですが、本作は北方亜種である *borealis* を参考としています。これは *laevis* よりも小型で、少々太めなのが特徴。水中での生活が主で陸上にあがることはなく、本当に図のようなポーズで水中に浮かんでいます。食欲旺盛で、実験室では牛レバーをサイコロ切りにしたものを与えていました。餌を前足で口にかき込む様子も、なかなかかわいらしいものでした。目と目の間をもう少し広くしたかったのですが、作品として自然なまとまりが得られたので、このままで完成形としました。

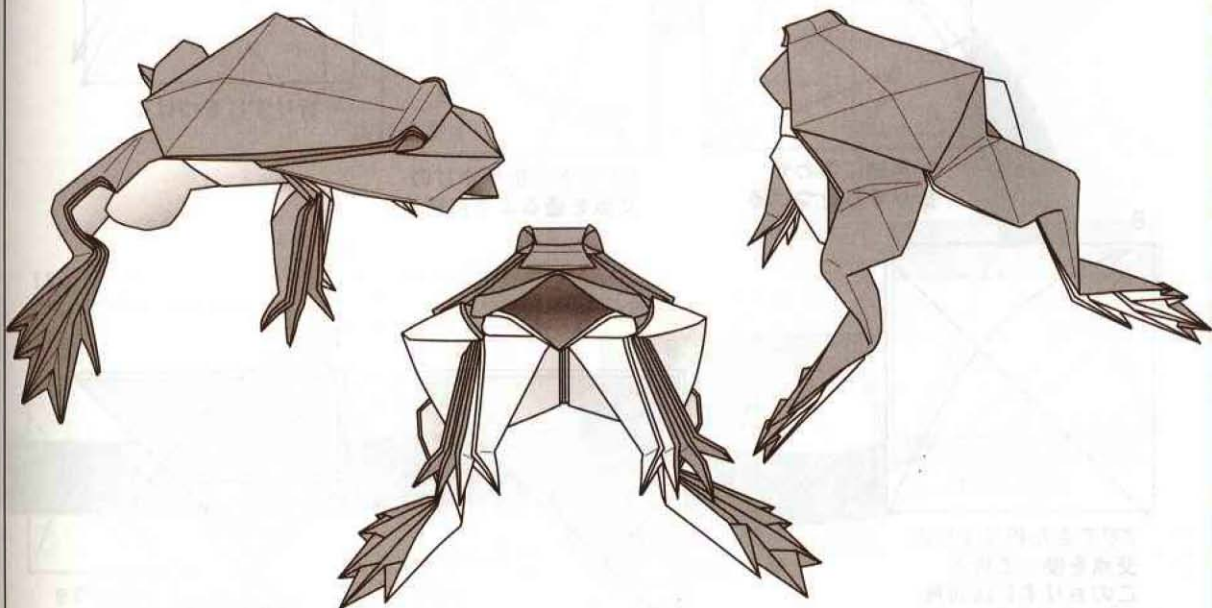

# マンタ

作図 2003.7.5

Kawahata Fumiaki 川畑文昭

約10年前のことですが、ある企画の展示用に吉野一生さんと私とでマンタの競作をしたことがあります。結局、吉野さんの素晴らしいマンタが展示用として選ばれたのですが、その時折った私の作品が最近段ボール箱の底から偶然見つかったため、これを機会に少し修正を加え折図にまとめてみました。

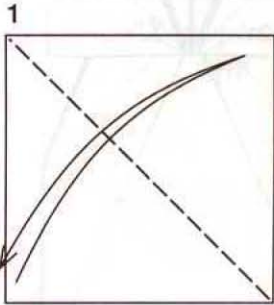
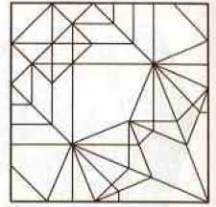

1 折りすじをつける

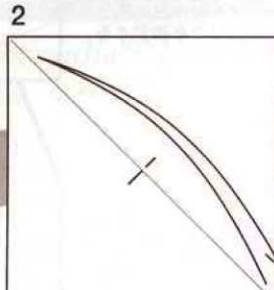

2 半分の位置に印をつける

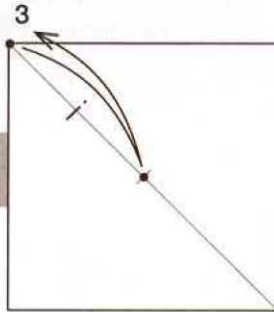

3 さらに半分の位置に印をつける

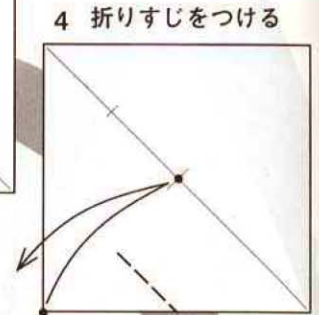

4 折りすじをつける

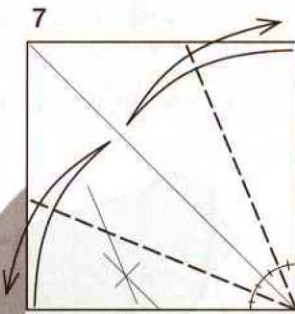

7 対角線にあわせ折りすじをつける

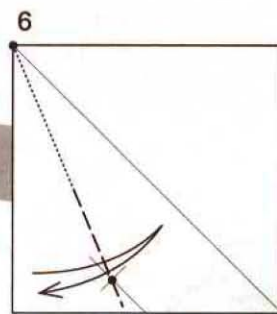

6 5でできた折りすじの交点を通るように折る

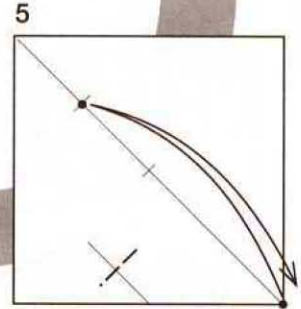

5 折りすじをつける

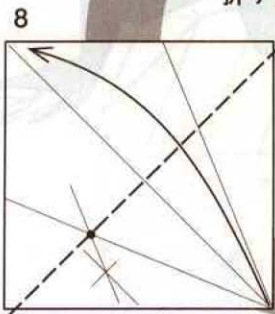

8 7でできた折りすじの交点を使って折る この折りすじは対角線ではないので注意

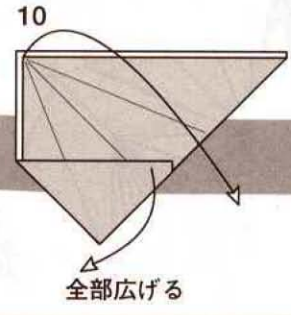
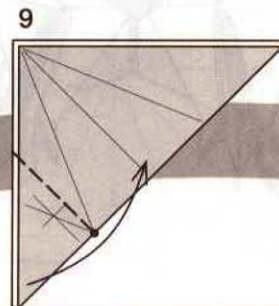

10 全部広げる

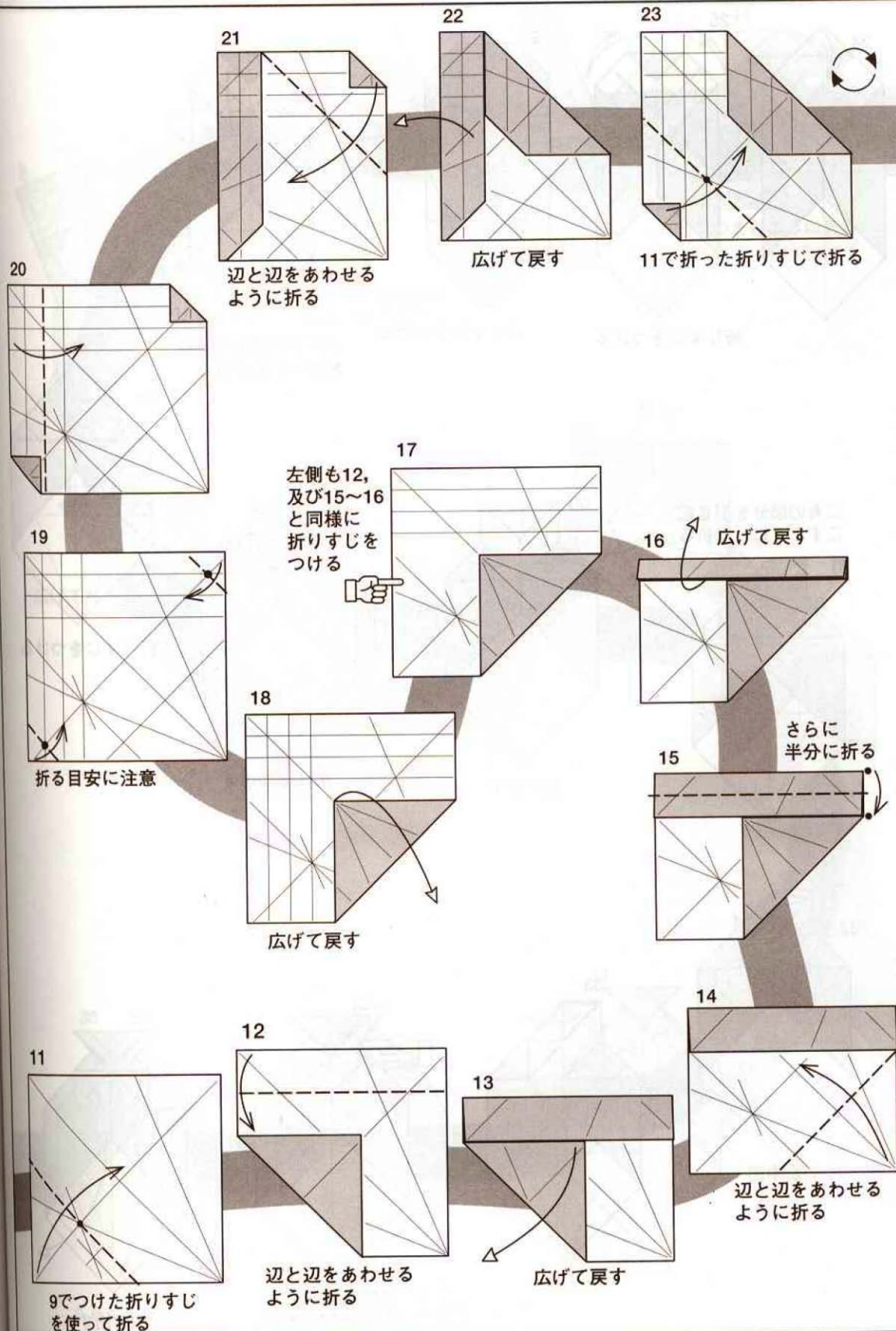

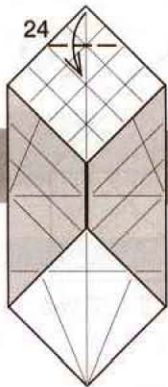

折りすじをつける

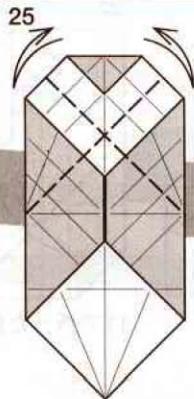

折りすじをつける

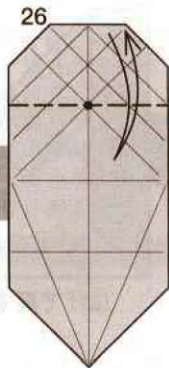

ついている折りすじ  
を使ってまとめる

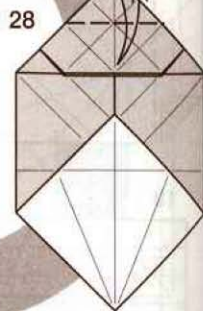
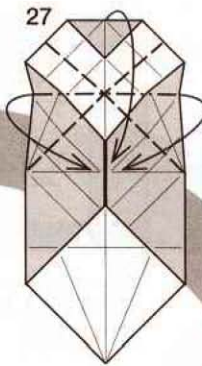

折りすじをつける

三角の部分を引き起  
こすようにして折る

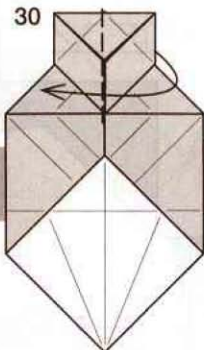
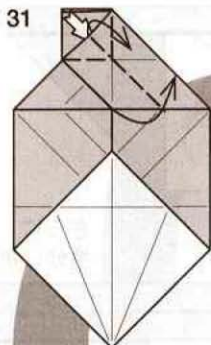

折り返す

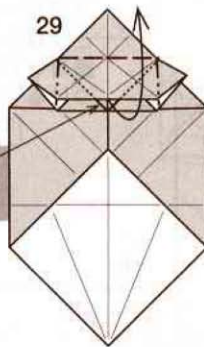

広げてつぶす

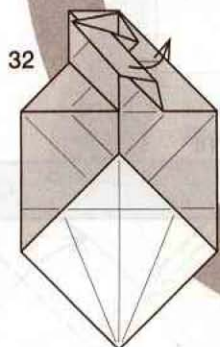

途中図

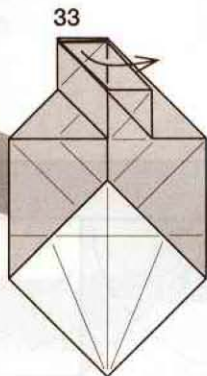

折り返す

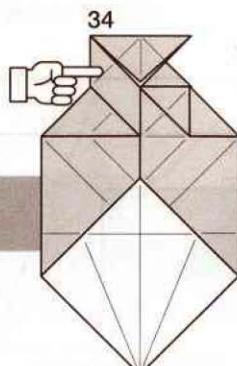

左側も30~33と  
同じように折る

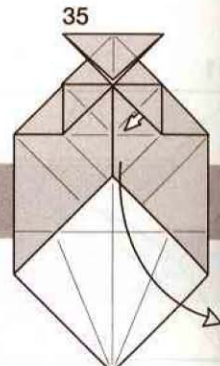

引き出す

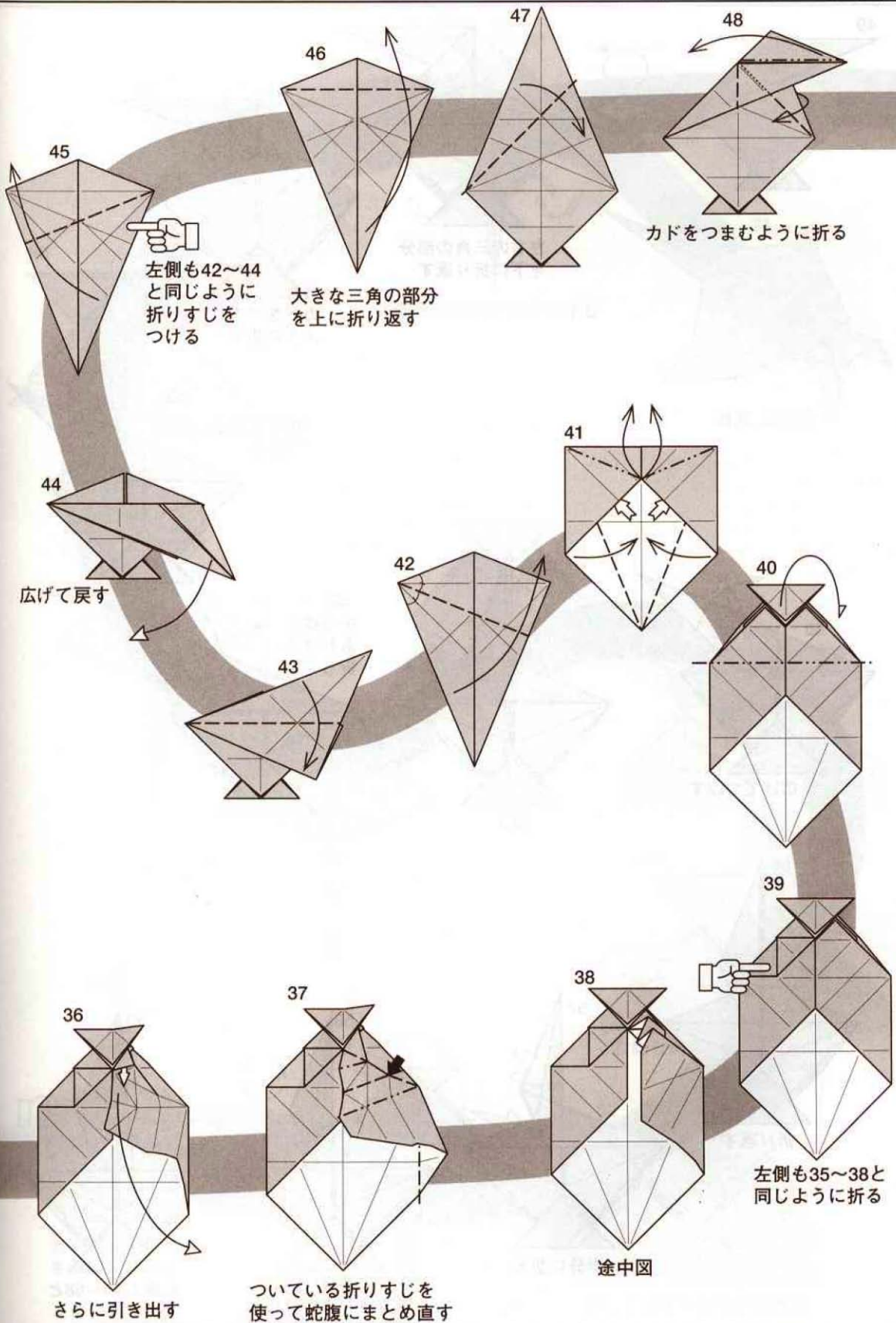

左側も42~44  
と同じように  
折りすじを  
つける

大きな三角の部分  
を上に戻す

カドをつまむように折る

広げて戻す

36

さらに引き出す

37

ついている折りすじを  
使って蛇腹にまとめ直す

38

途中図

39

左側も35~38と  
同じように折る

40

42

41

43

46

47

48

45

49

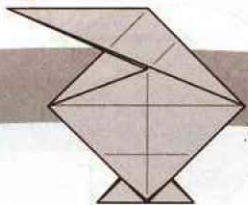

50

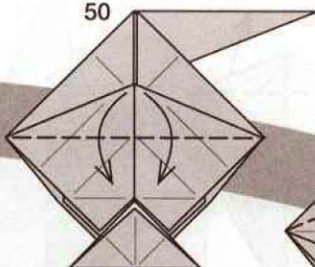

左右の三角の部分  
を下に折り返す

51

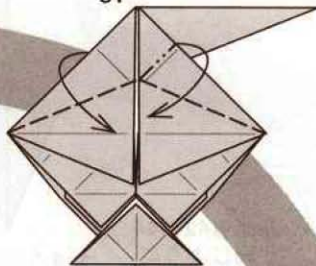

カドをつまむ  
ように折る

52

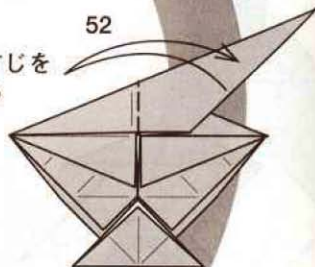

折りすじを  
つける

54

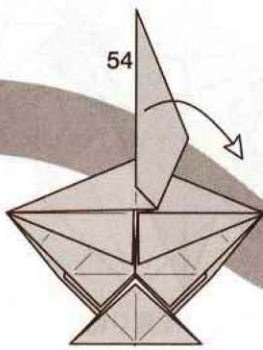

戻す

53

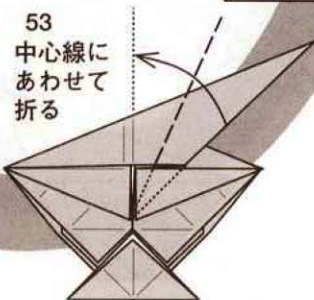

中心線に  
あわせて  
折る

55

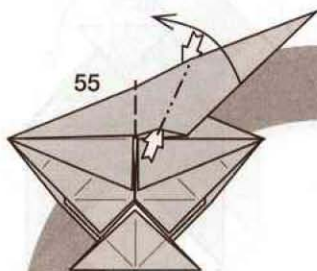

広げてつぶす

56

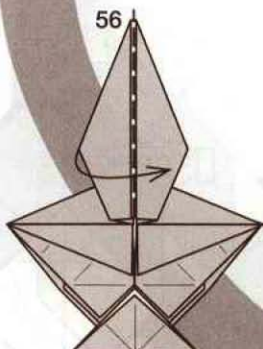

折り返す

57

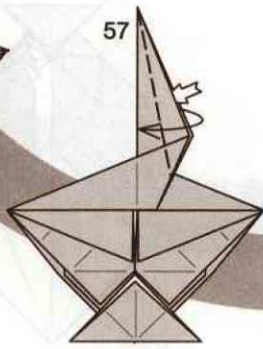

半分に折る

58

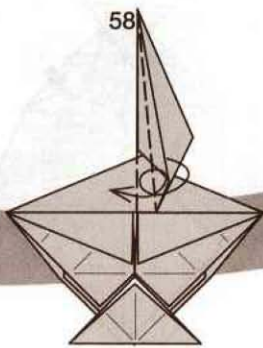

さらに半分に  
巻き込むように折る

59



右側も55~58と  
同じように折る



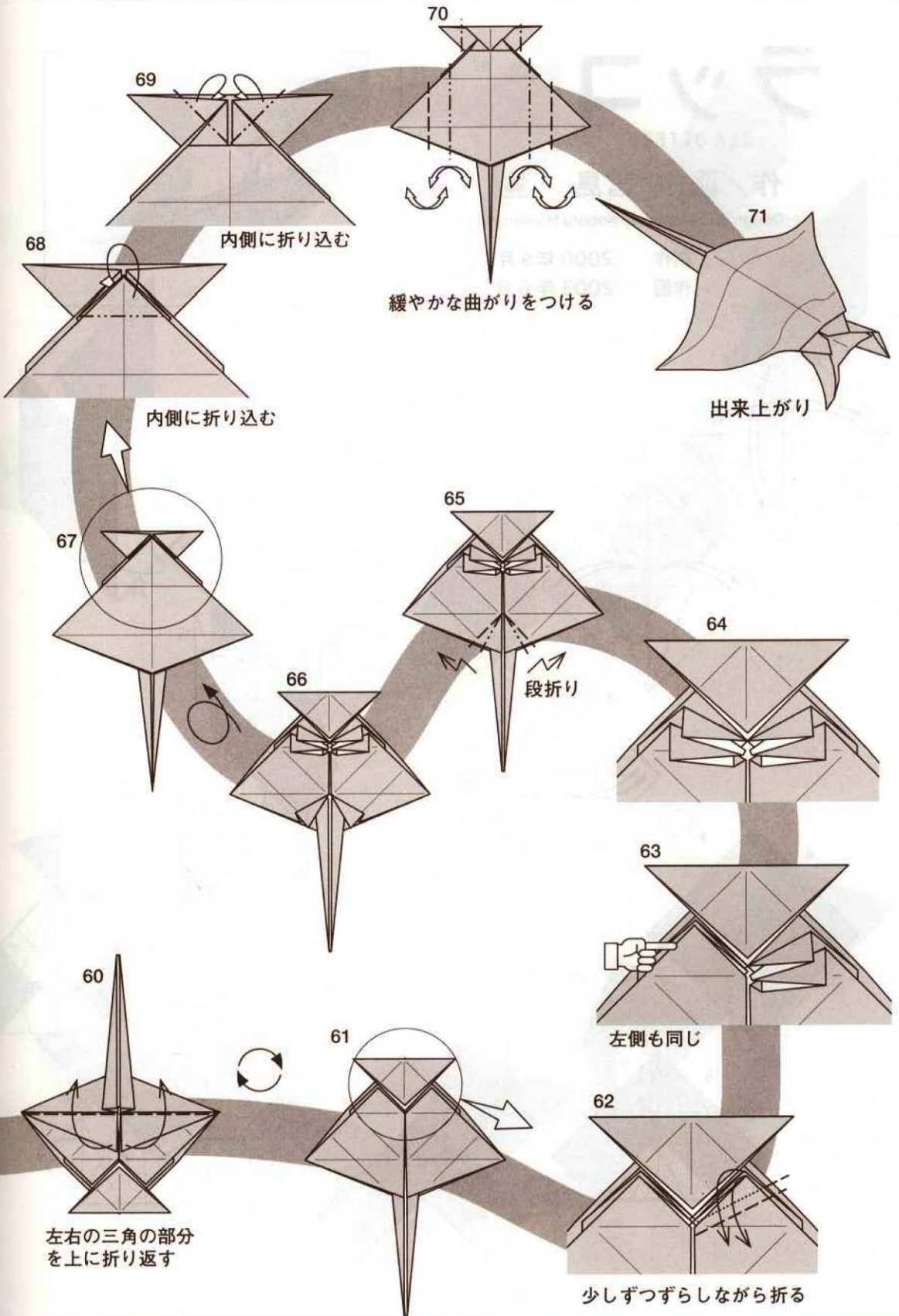

# ラッコ

SEA OTTER

作/図 宮島 登

Design & Diagrams By Noboru Miyajima

創作 2000年9月

作図 2003年6月

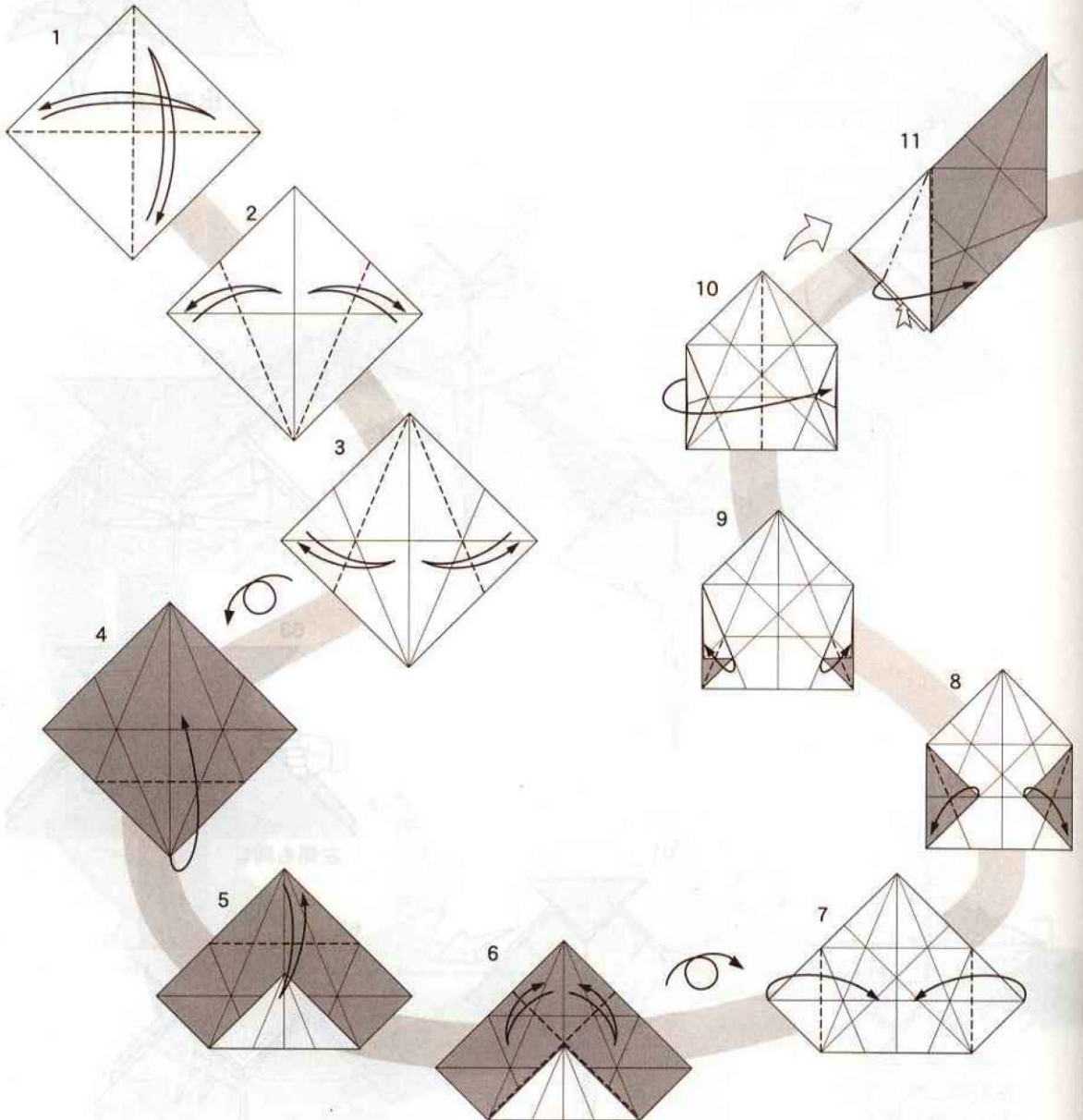
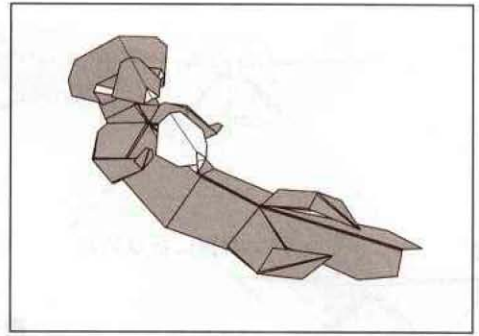

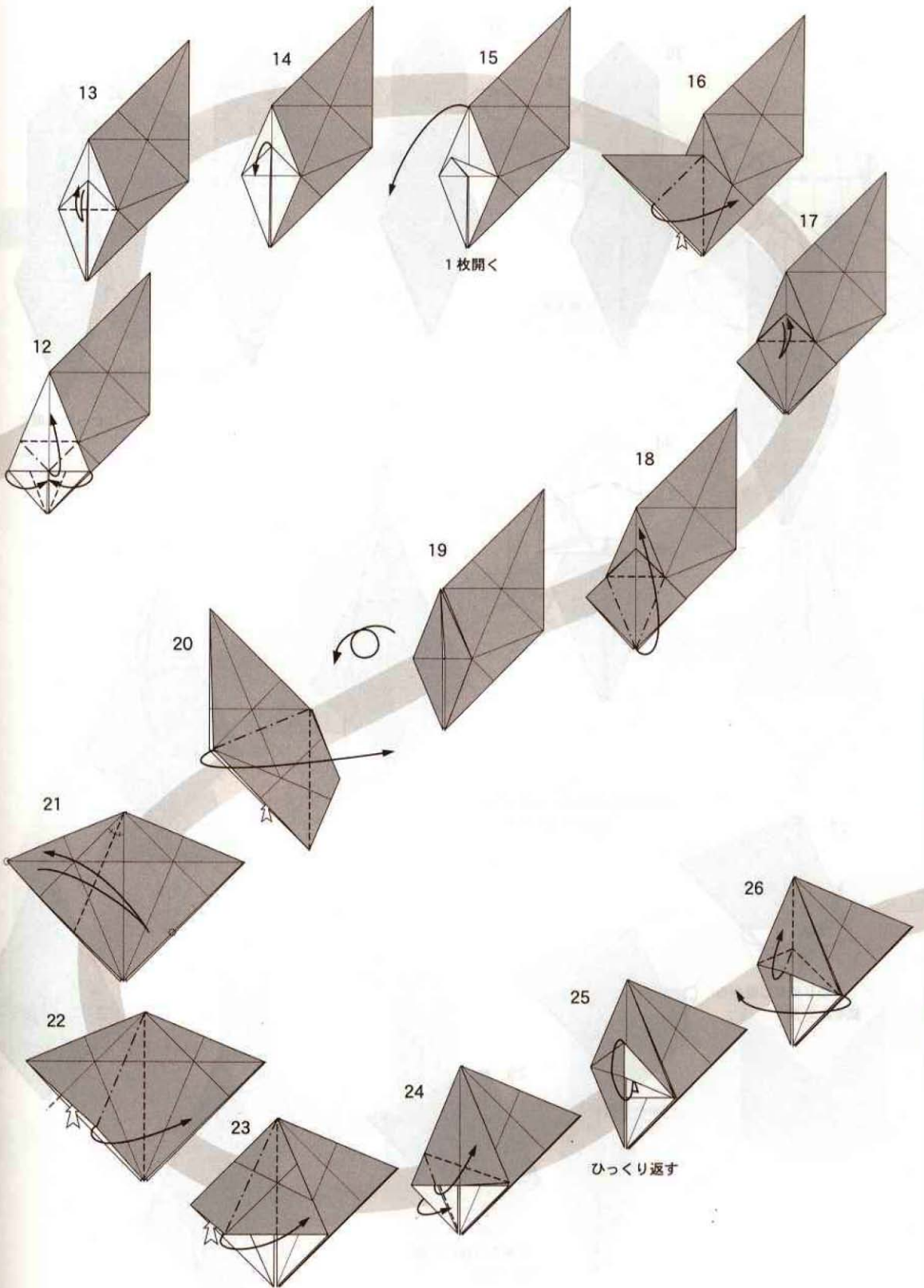

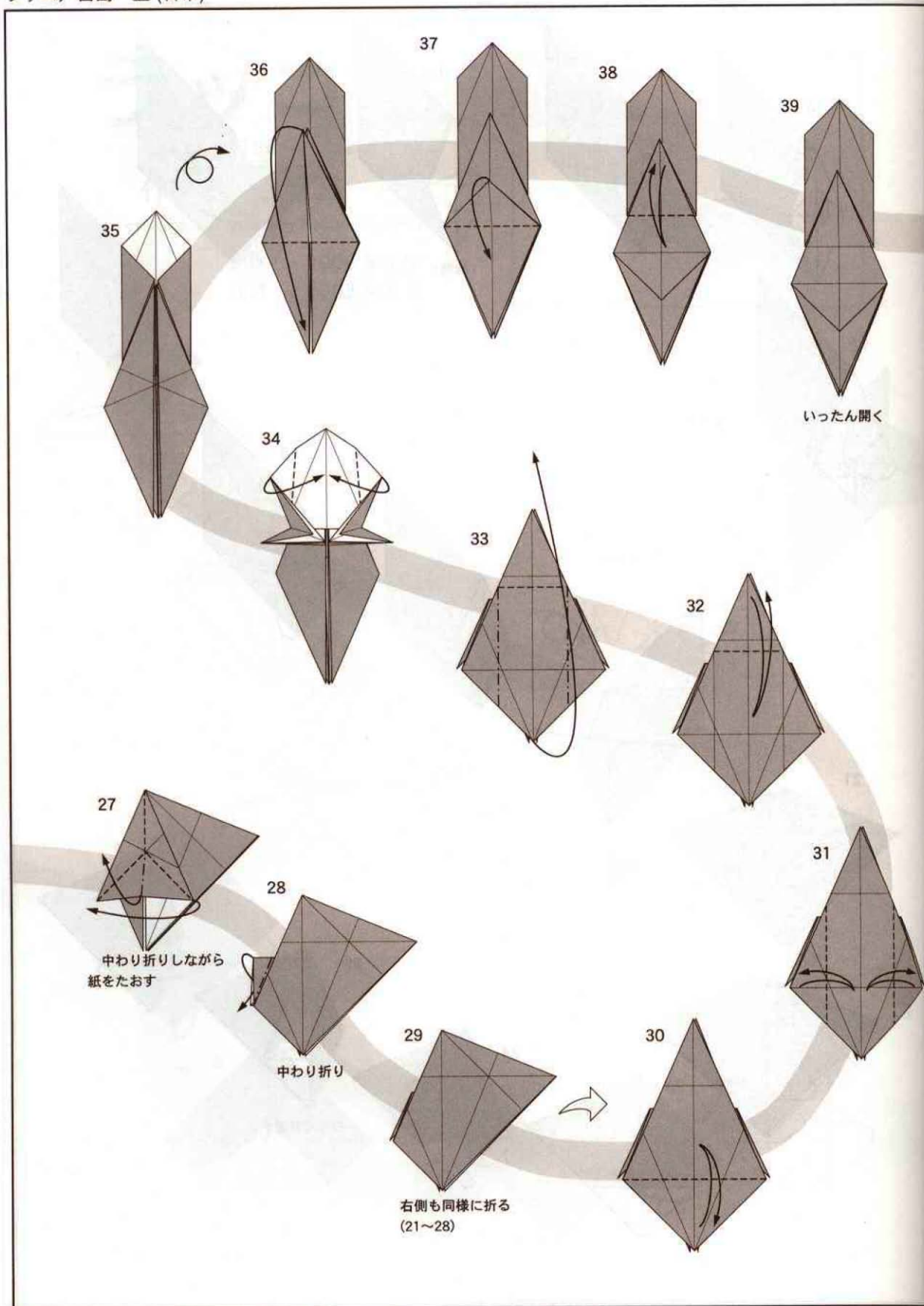

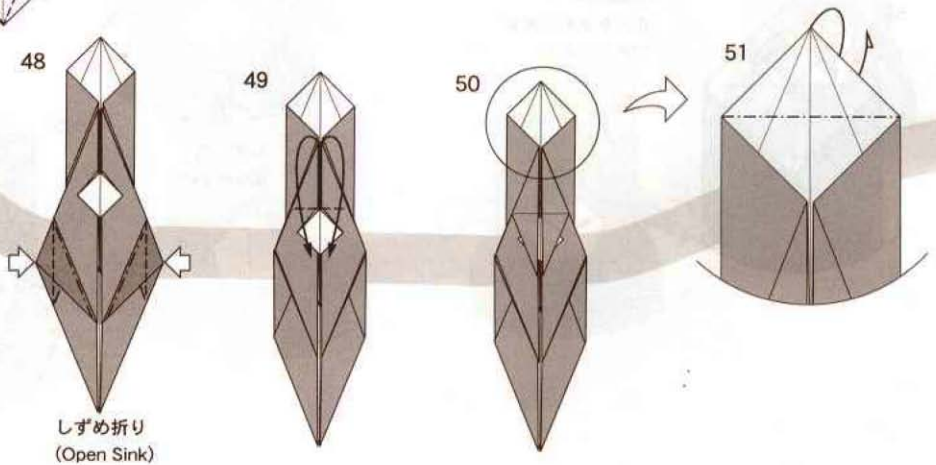
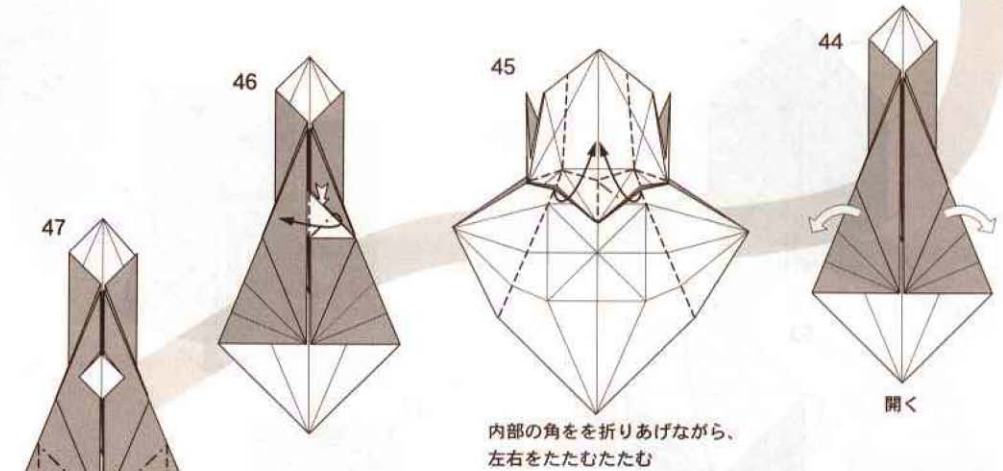
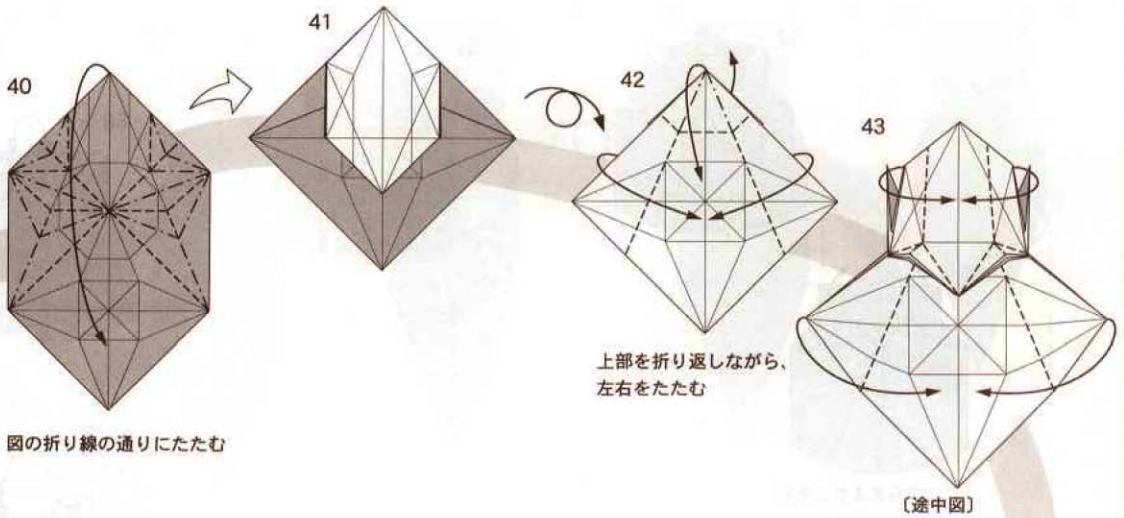

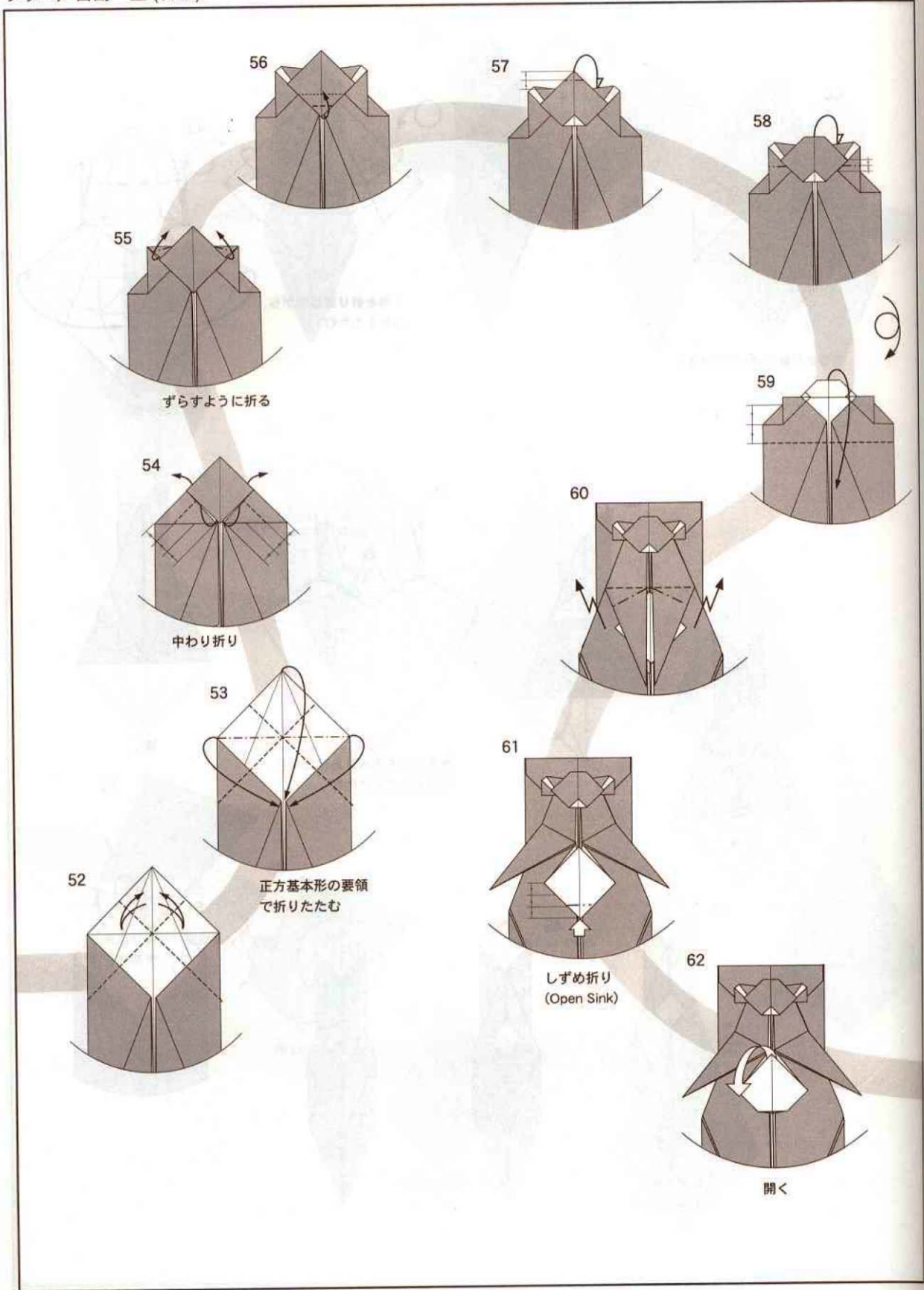

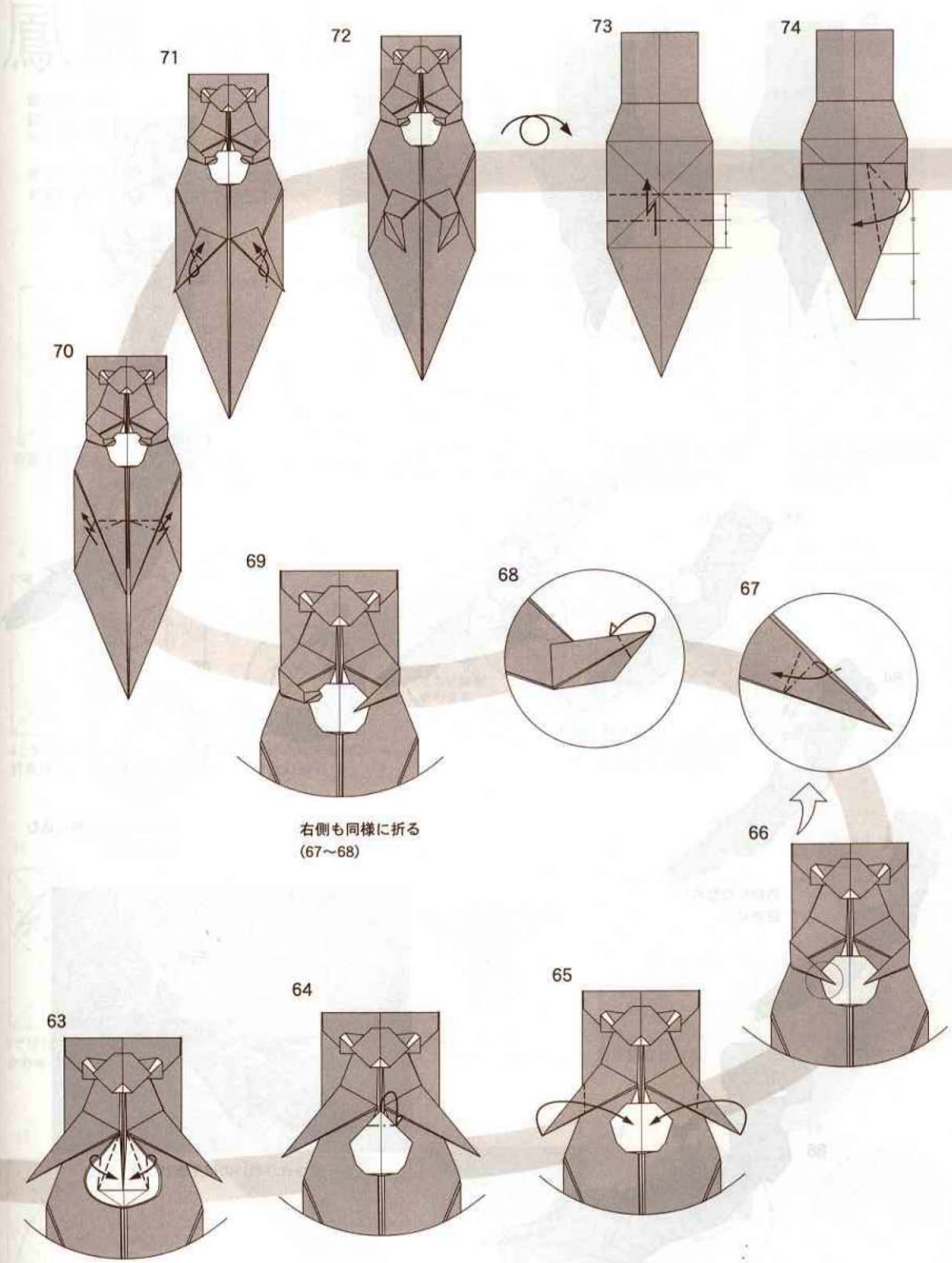

右側も同様に折る  
(67~68)

75

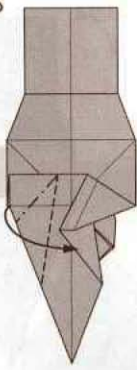

76

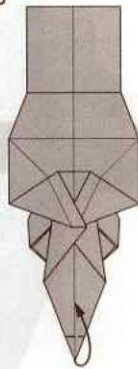

77

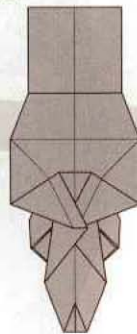

78

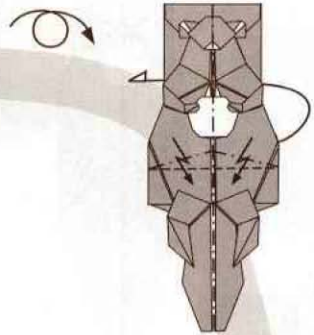

79

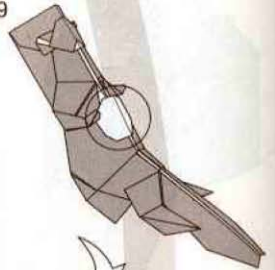

83

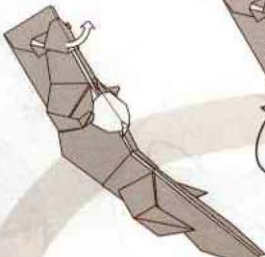

82

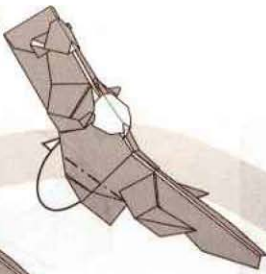

81

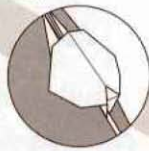

80

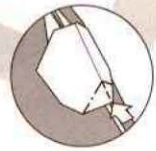

白矢印部分を押し込むように折る

84

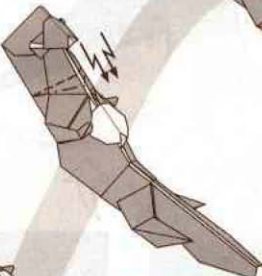

上に引き上げる

85



内側にななめに段折り

86

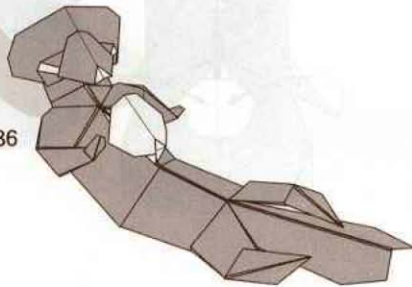

できあがり



目つきが悪いのは生まれつき



# 鳳凰 (ほうおう)

創作者：山口 智之  
 創作：2003年5月  
 作図：2003年5月

尾と内部の構造に見られる「沈め段折り」  
 が難所。折り線をしっかり付けて下さい。

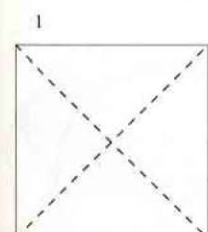
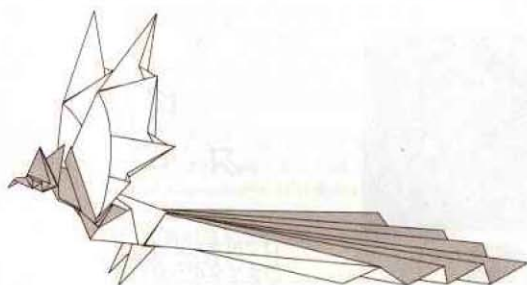

1 折線を付ける

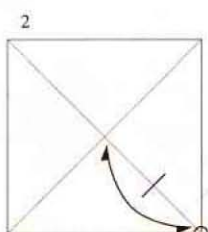

2 ○を中心に合わせ対角線の上に印を付ける

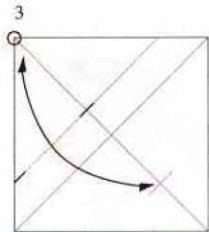

3 ○を2で付けた印に合わせ対角線とふちに印を付ける

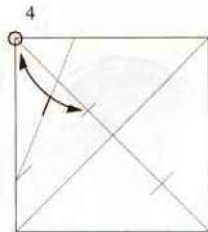

4 ○を3で付けた印に合わせて折り線を付ける

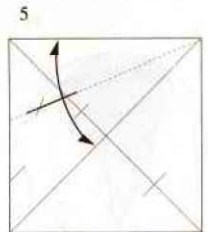

5 ふちを対角線に合わせ印を付ける

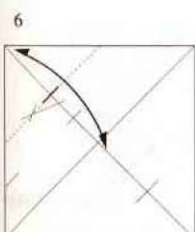

6 4と5の交点を基準として対角線上に印を付ける

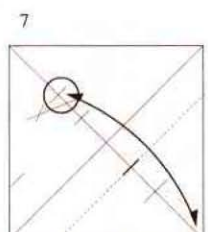

7 5と6で付けた印の2/3の所に角を合わせる

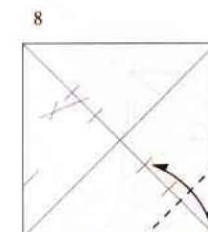
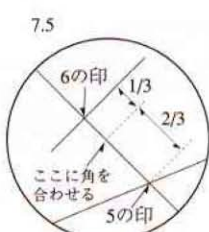

8 角を7に合わせて折る ※以下2~7は省略

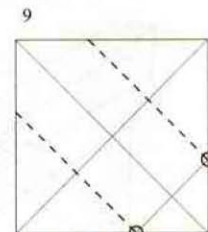

9 ○を基準に折り線を付ける

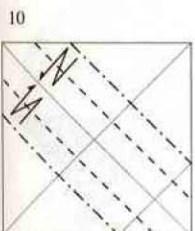

10 9で付けた線を中心線に合わせて段折り

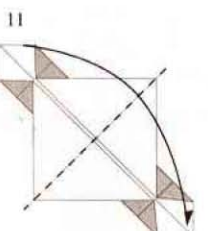

11 半分に折る (次図は45°回転して見る)

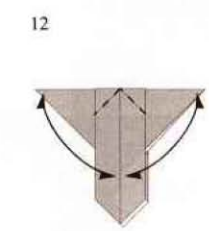

12 折線を付ける (次図は全部広げる)

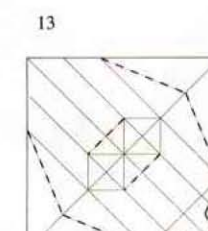

13 折り線を付ける

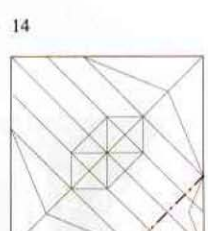

14 角を裏側へ折る

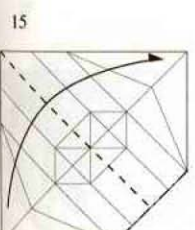

15 半分に折る

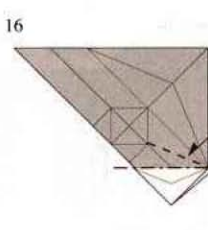

16 折り線を付ける △で示した線は工程43で重要な線となる

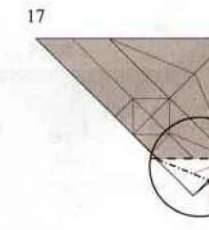

17 開いてつぶす丸の中を拡大

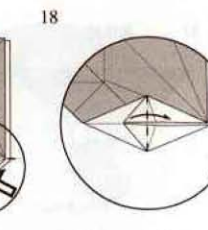

18 角をめくるように折る

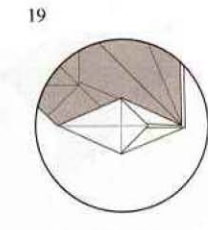

19 全部広げる (拡大終了)

20

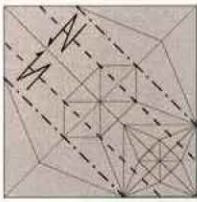

中心線に合わせるように段折り (次図は裏返す)

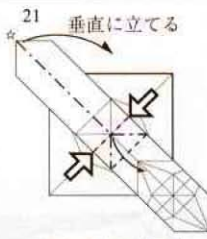

21 垂直に立てる  
12で出来た正方形を凹ませながら☆の角を垂直に立てる

22

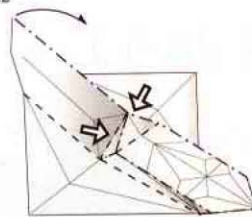

途中の図

23

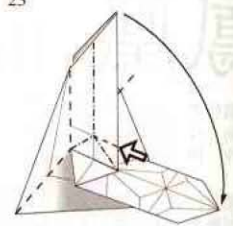

更に矢印部分を押し込むようにして平面にたたむ

24

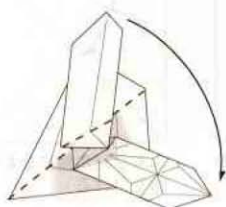

途中の図

25

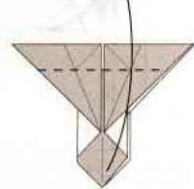

いっばいに折れる所で折り上げる

26

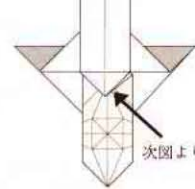

次図より拡大

27

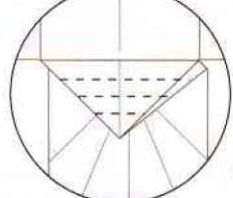

4等分の折り線を付け半開きにする

28

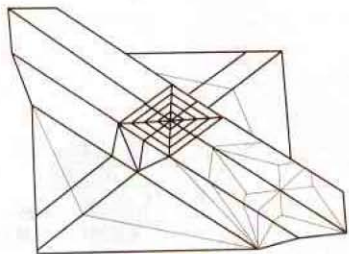

この図において細線で示した線を次図では省略する

29

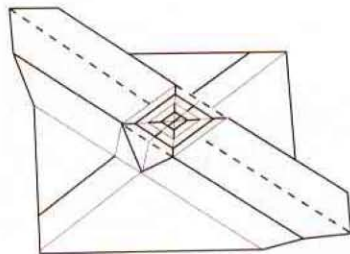

この図では太線を山折、細線を谷折とする  
なお、-----は本来は谷折を示す線であるがこの図においては山にも谷にも折らない線であることを示す

30

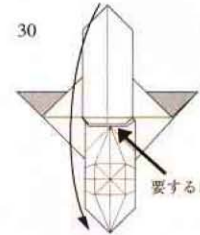

要するに沈め段折

角を折り下げる

31

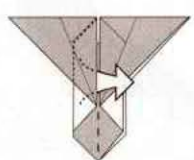

裏返すように引き出す (上の方はClosed Sinkの要領)

32

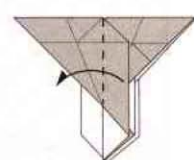

めくる

33

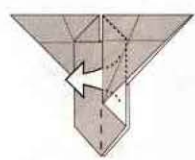

反対側も同じ 裏側も同じ

34

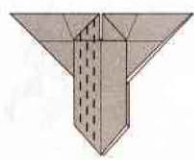

4等分

35

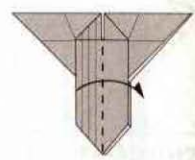

めくる

36

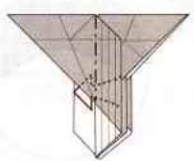

押し込む (31の逆)

37

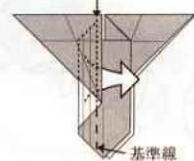

31の要領で裏返すように引き出すが、基準となる折り線は中心線より1つ左側の折り線となる。

38

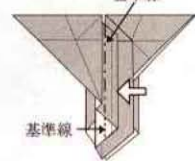

基準線に注意して36の要領で裏返すように押し込む

39

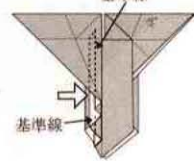

基準線に注意して37の要領で裏返すように押し込む

40

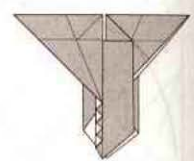

反対側も同じ (34~39)

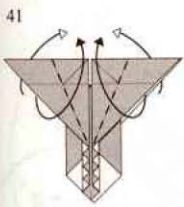

かぶせ折

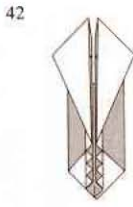

裏返す

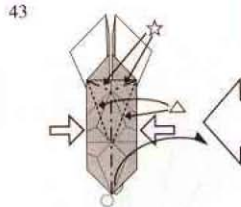

矢印の部分をもみながら16の△で示した折線を山折にする。この面からは見えないが、△で示した線を外側から見て山折にする。☆で示した山折線はこの工程で新たに付く線であるが紙をゆがみなくするため自動的に付く線である。○の角が浮き上がってくるので右側へたおす。

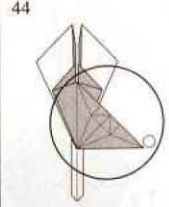

○の中を拡大

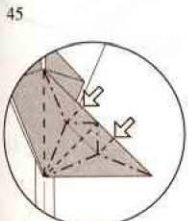

鶴の基本形をたたむ

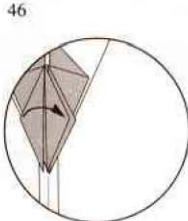

めくる  
(更に拡大)

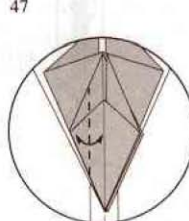

折り線を付ける

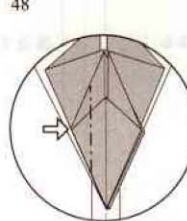

沈め折り  
(open sink)

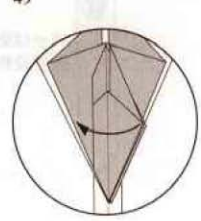

めくる

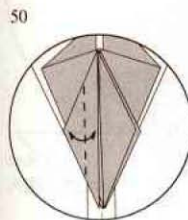

折り線を付ける

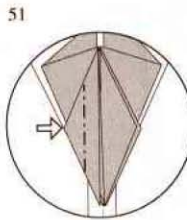

沈め折り  
(open sink)

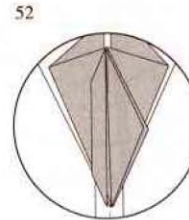

反対側も同じ  
(47~51)

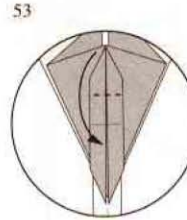

後ろの角に合わせて  
角を折り下げる

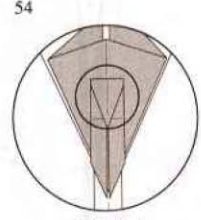

更に拡大

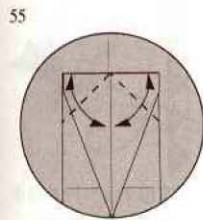

折り線を付ける  
53の形に戻す

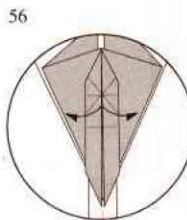

半開きにする

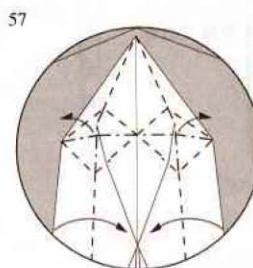

凹のひし形を凸にして閉じる

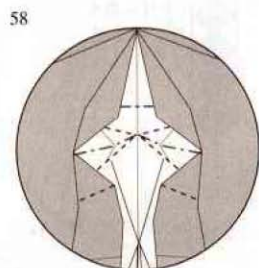

途中の図

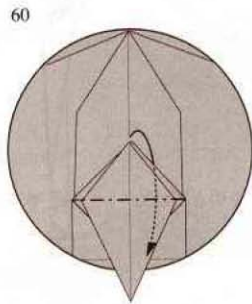
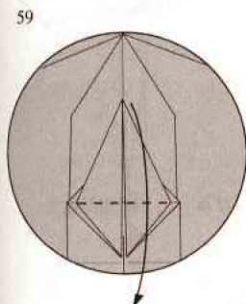

角を2枚後ろ側へ折る

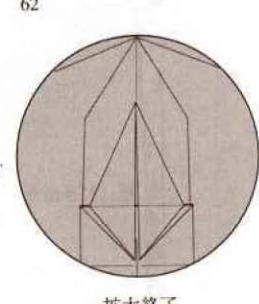
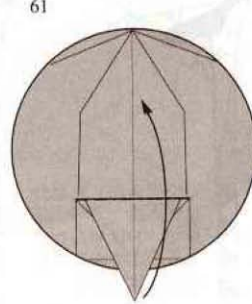

拡大終了

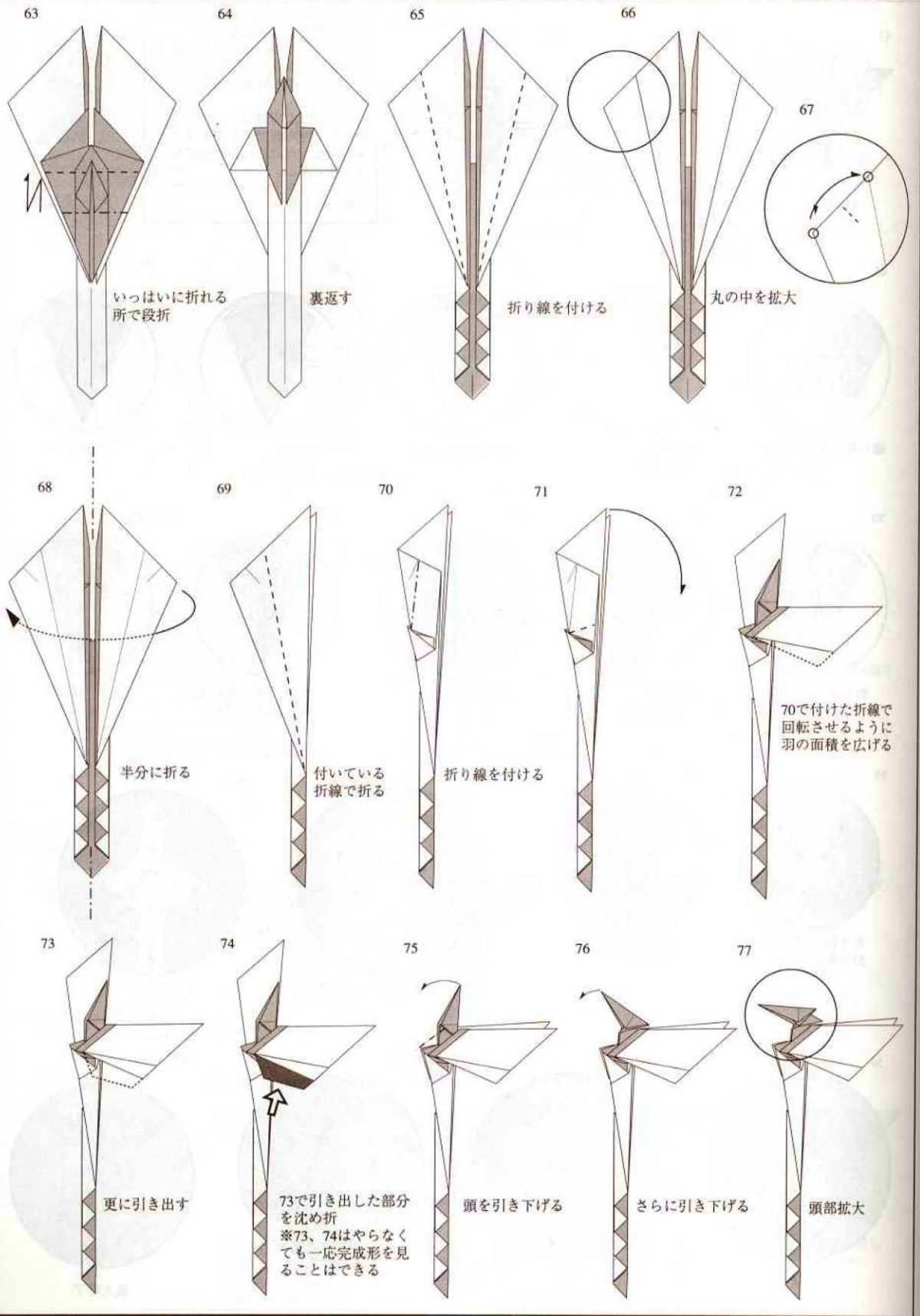

78

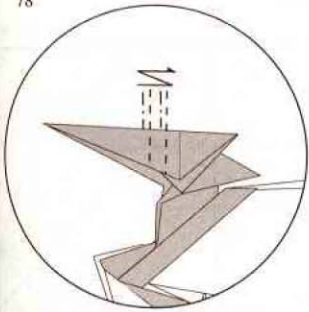

かぶせるように段折

79

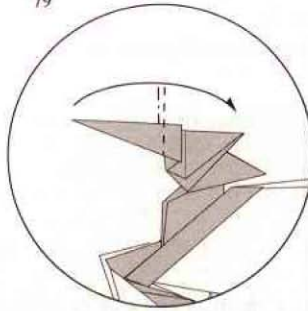

かぶせ折

80

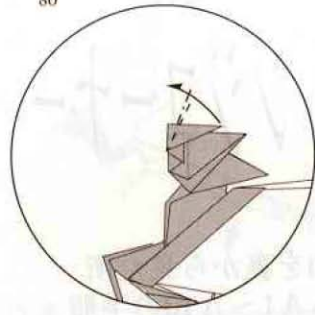

かぶせ折

81

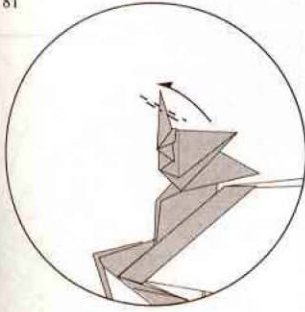

中わり折  
次図は翼を拡大

82

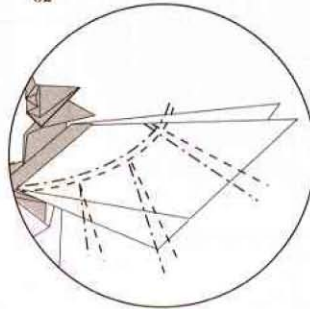

翼に表情を付ける

83

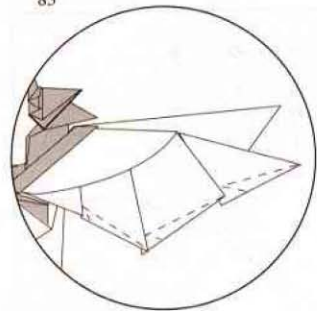

85

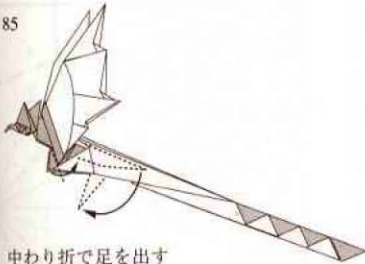

中わり折で足を出す

86

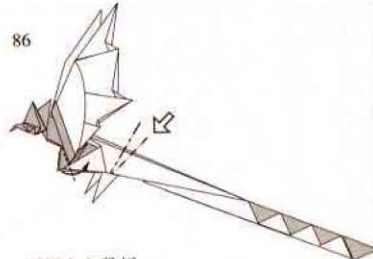

両側から段折  
矢印の方から見ると13層あるが手前側から6層  
向こう側から6層づつ段折をする。  
真ん中の層は、どちらか片側に寄せるか凹ませて  
次図のようにまとめる。

86.5

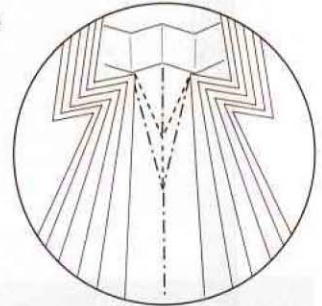

完成 (一応・・・)  
アレンジコーナーへ続く

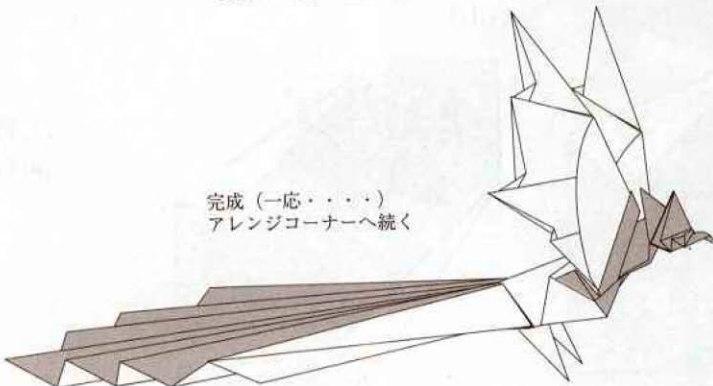

# アレンジコーナー

図20を裏から見た所からA1～A10の手順で折り線を付ける。

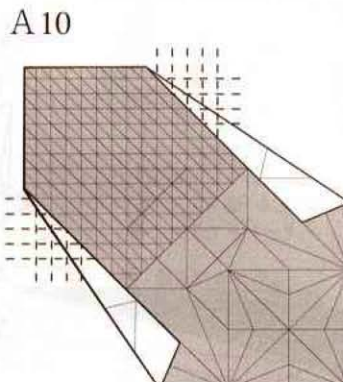
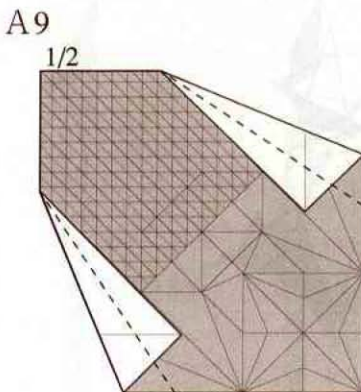
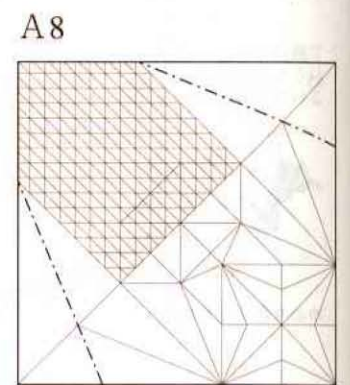
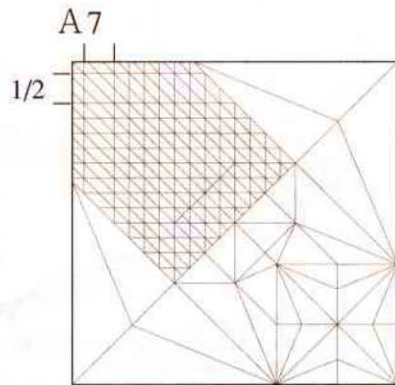
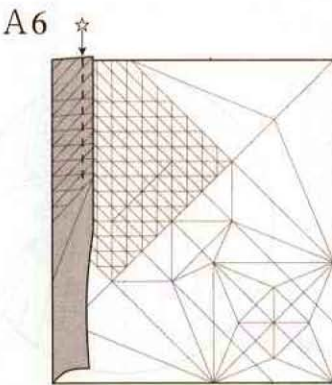
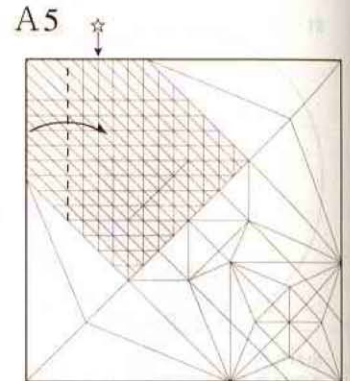
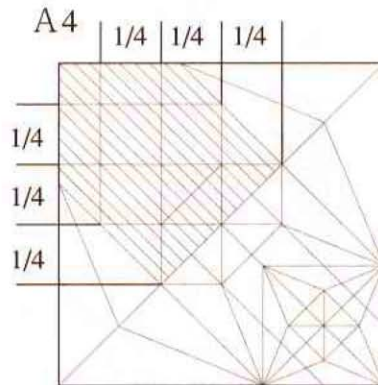
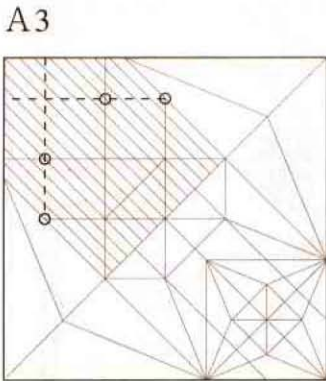
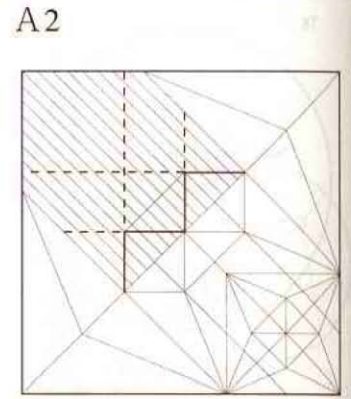
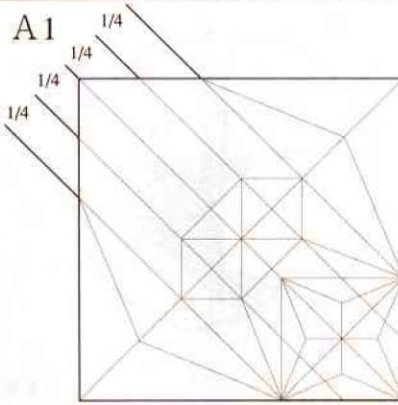

A11

工程20～85まで同様に折る。

アレンジ1

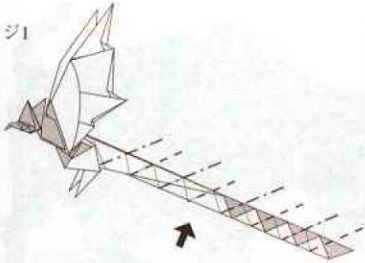

アレンジ2

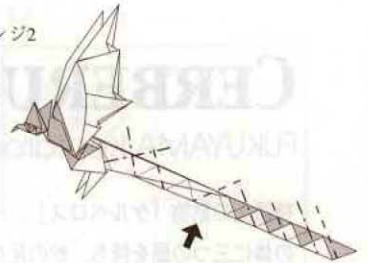

開いた中割折り (Opensink) を繰り返す。  
 図に示される折線は、尾を半開きにし  
 矢印の方から見てつながっている線を  
 全て山 (もしくは谷) にする。

実際には尾の部分のみを半開きにして作業します

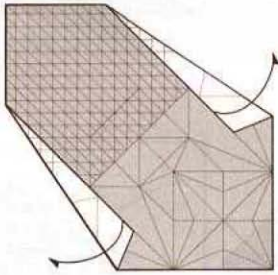

工程A10を次図のように開いて

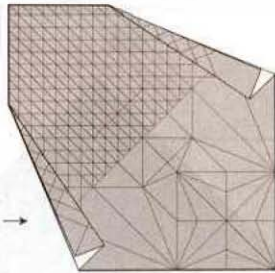

次図では裏返す

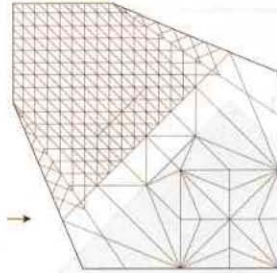

アレンジ1

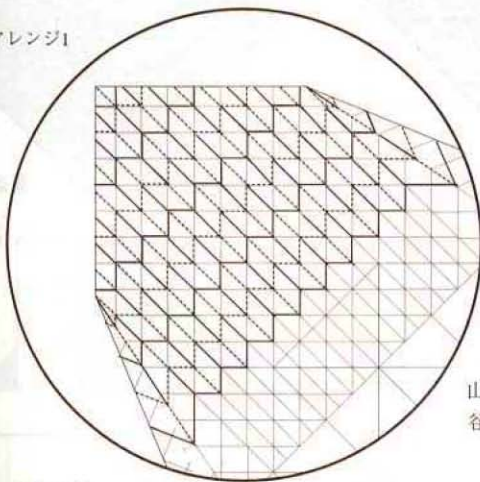

アレンジ2

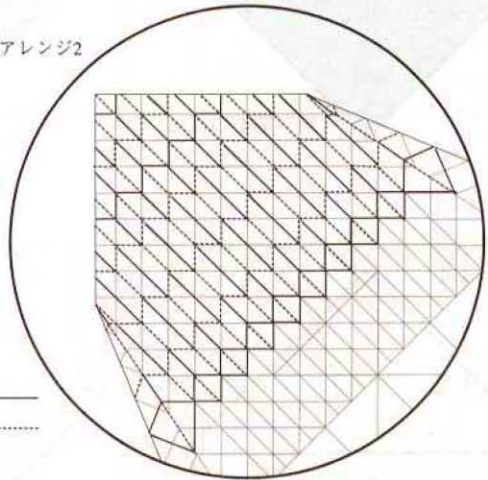

山 ———  
 谷 - - - - -

アレンジ1

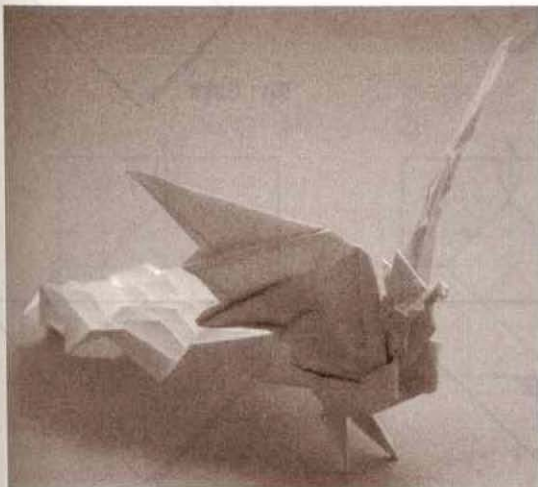

アレンジ2



# CERBERUS

FUKUYAMA Kentarou

神話上の動物「ケルベロス」。一つの体に三つの頭を持ち、蛇の尾を持つ犬。地獄の番犬。

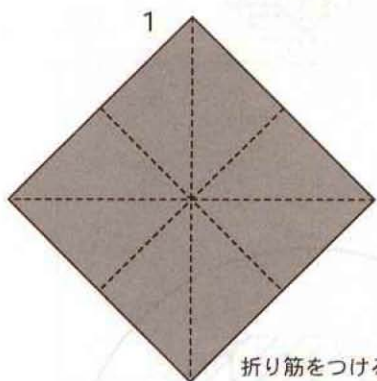
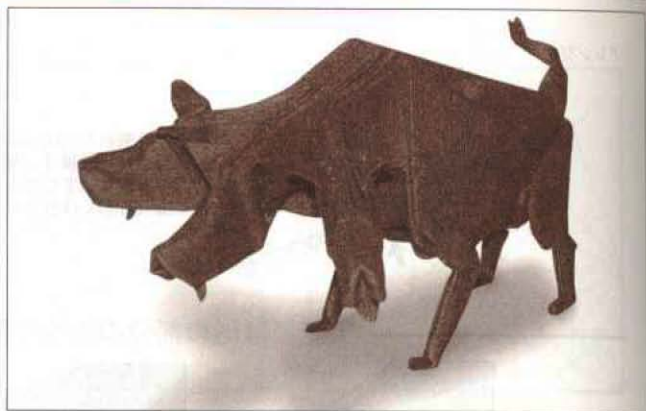

折り筋をつける

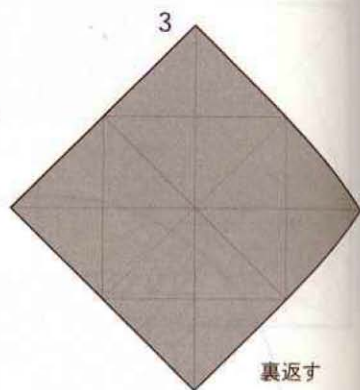
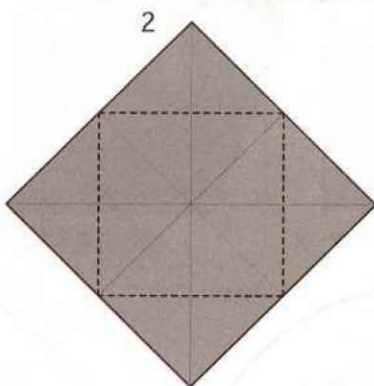

裏返す

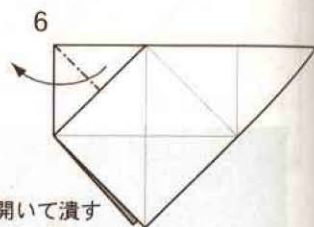
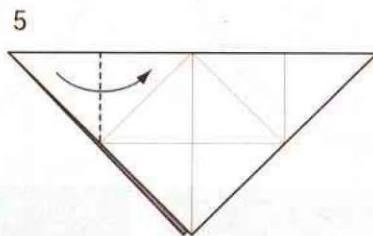
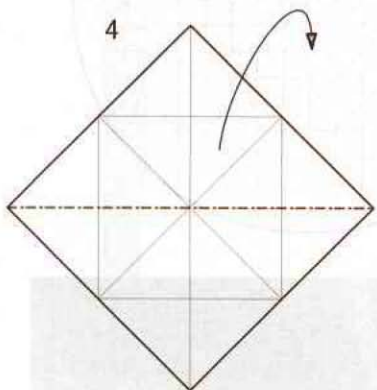

開いて潰す

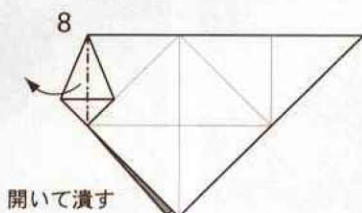
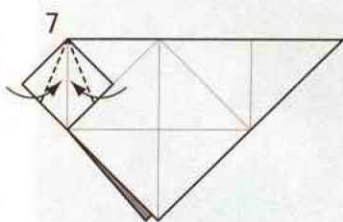

開いて潰す

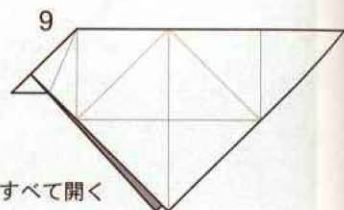

すべて開く



10

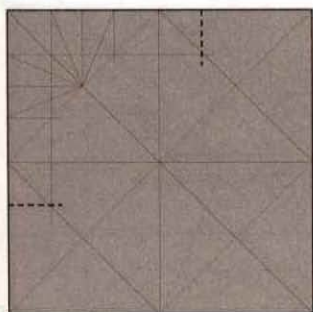

折り筋をつける

11



裏返す

12

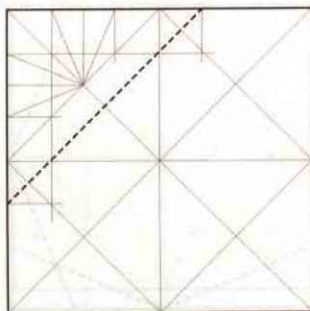

51にすくい折

13

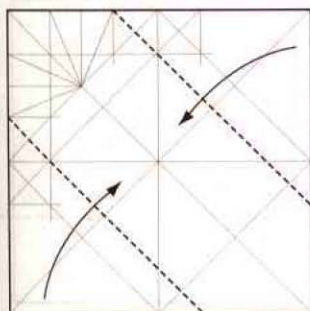

14

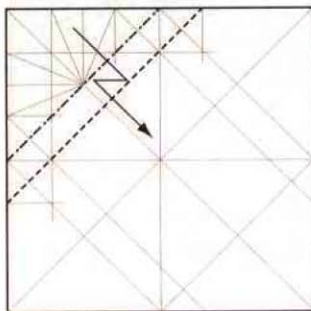

段折り

15

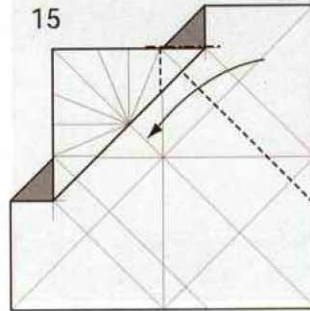

16

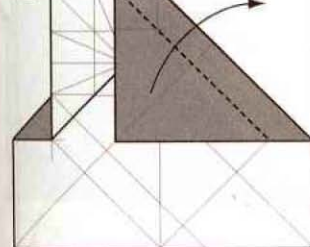

17

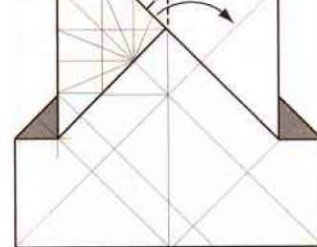

開いて潰す

18

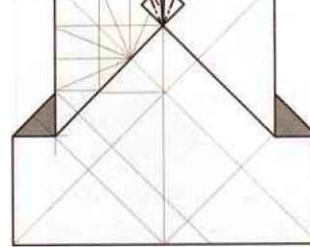

開いて潰す

19

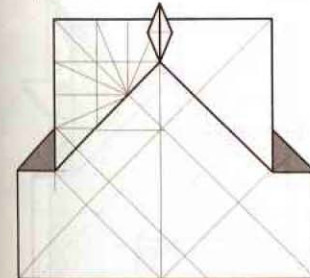

反対も15~19と同じ

20

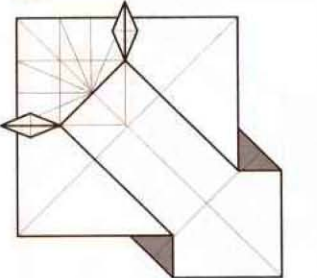

すべて開く

21

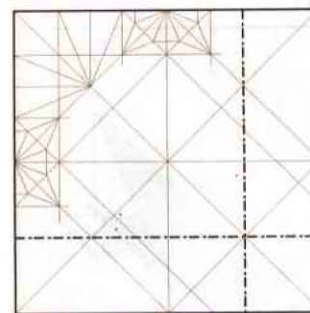

22

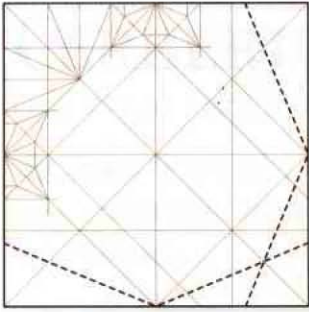

折り筋をつける

23

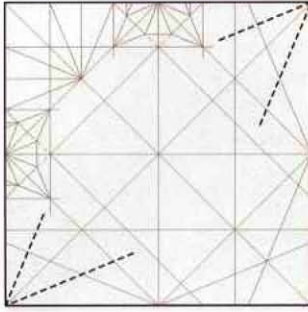

24

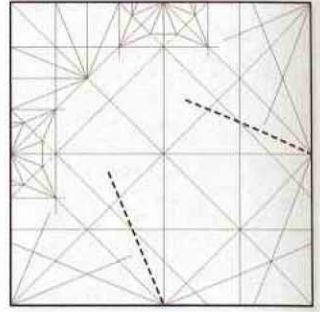

裏返す

25

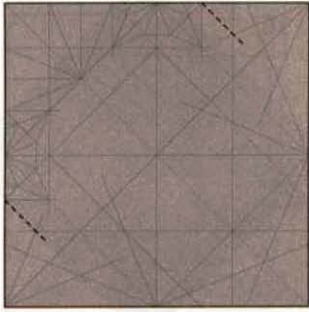

裏返す

26

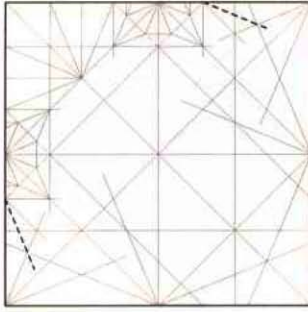

27

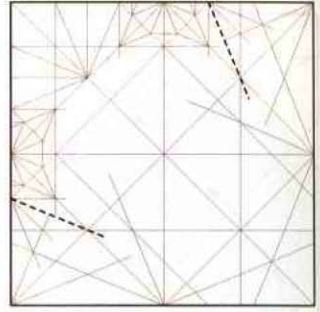

28

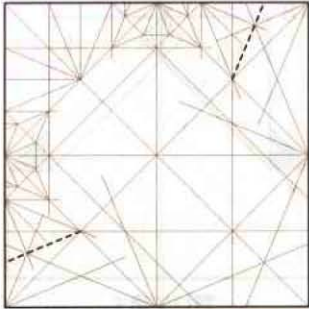

28

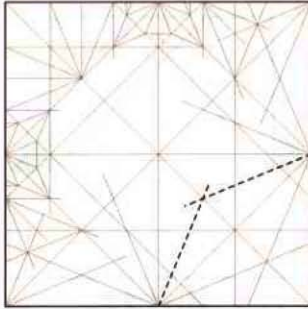

30

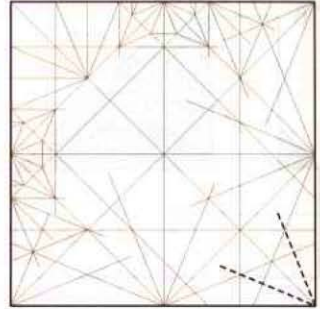

31

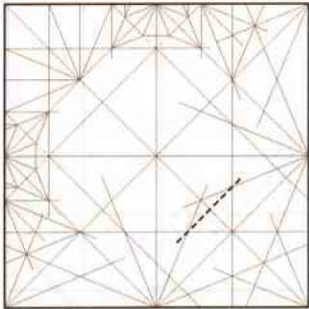

32

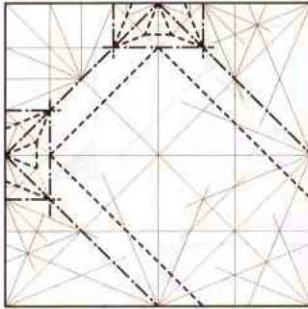

折り筋に沿って折り畳む

33

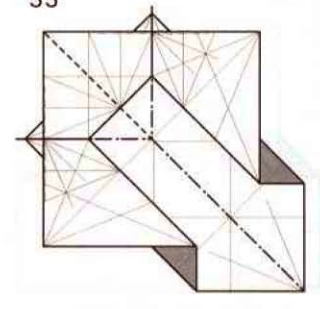

折り筋に沿って折り畳む

34

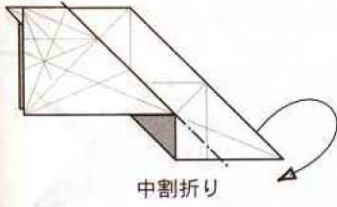

中割折り

35

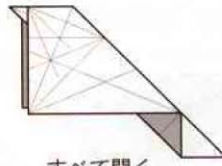

すべて開く

36

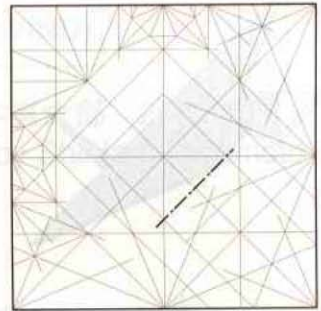

37

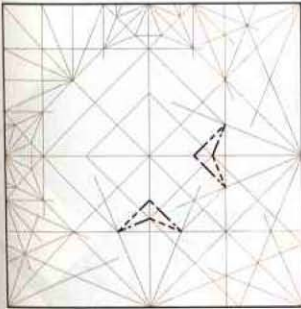

38

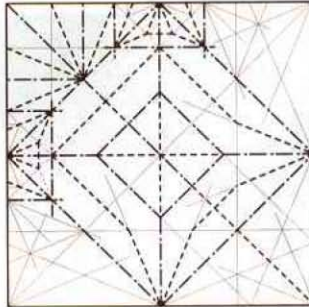

折り筋に沿って折り畳む

39

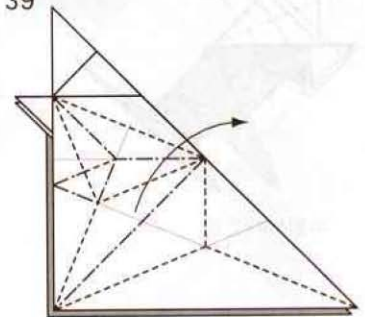

折り筋に沿って折り畳む

40

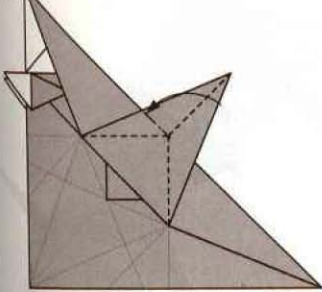

つまむ様にして折る

41

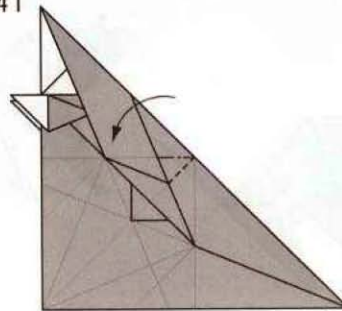

中割折り

42

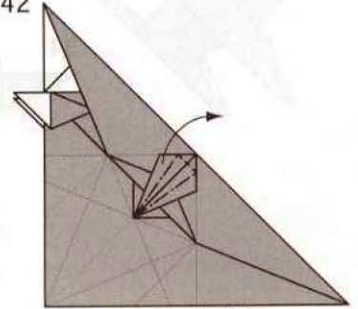

ひらいて潰す

43

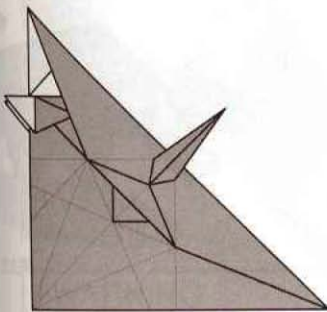

反対も39~42と同じ

44

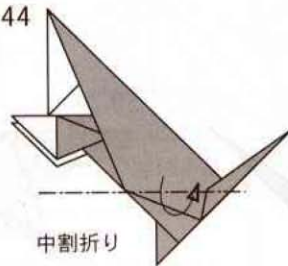

中割折り

45

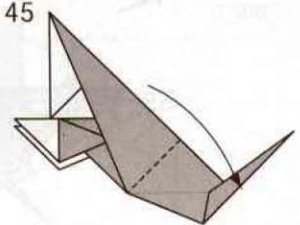

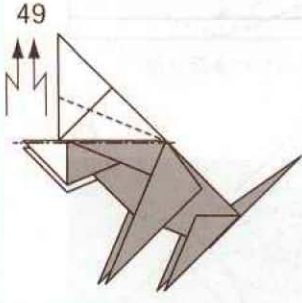
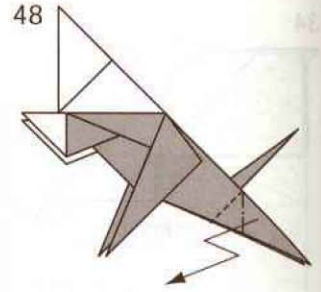
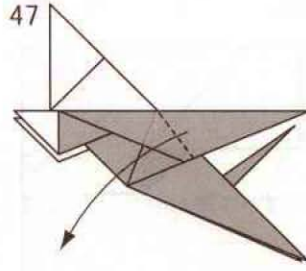
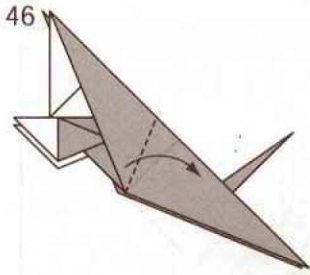

中割折り二回

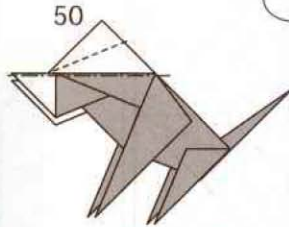

中割折り二回

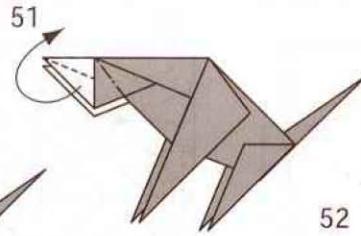

中割折り

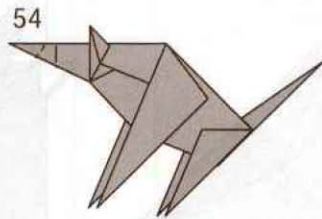
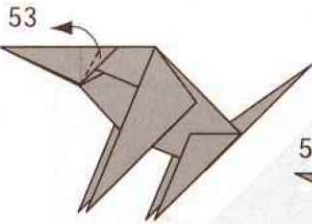
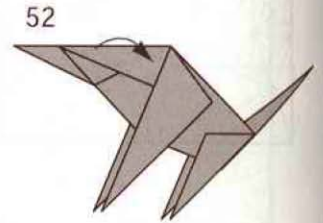

中割折り二回

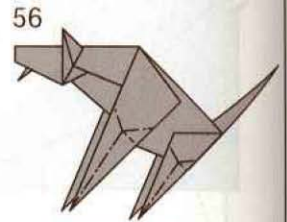
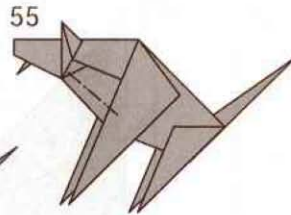

つまみ折り



中割折り

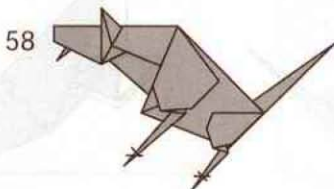

中割折り二回

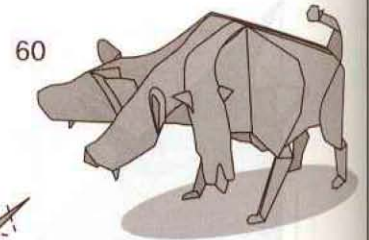
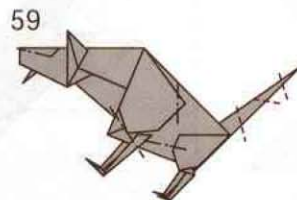

完成

◆ GSC.No.245:北風の生まれ変わり(THE NORTH WIND)

創作：宮本真太郎 2002/10/6  
Designed by Shintaro Miyamoto

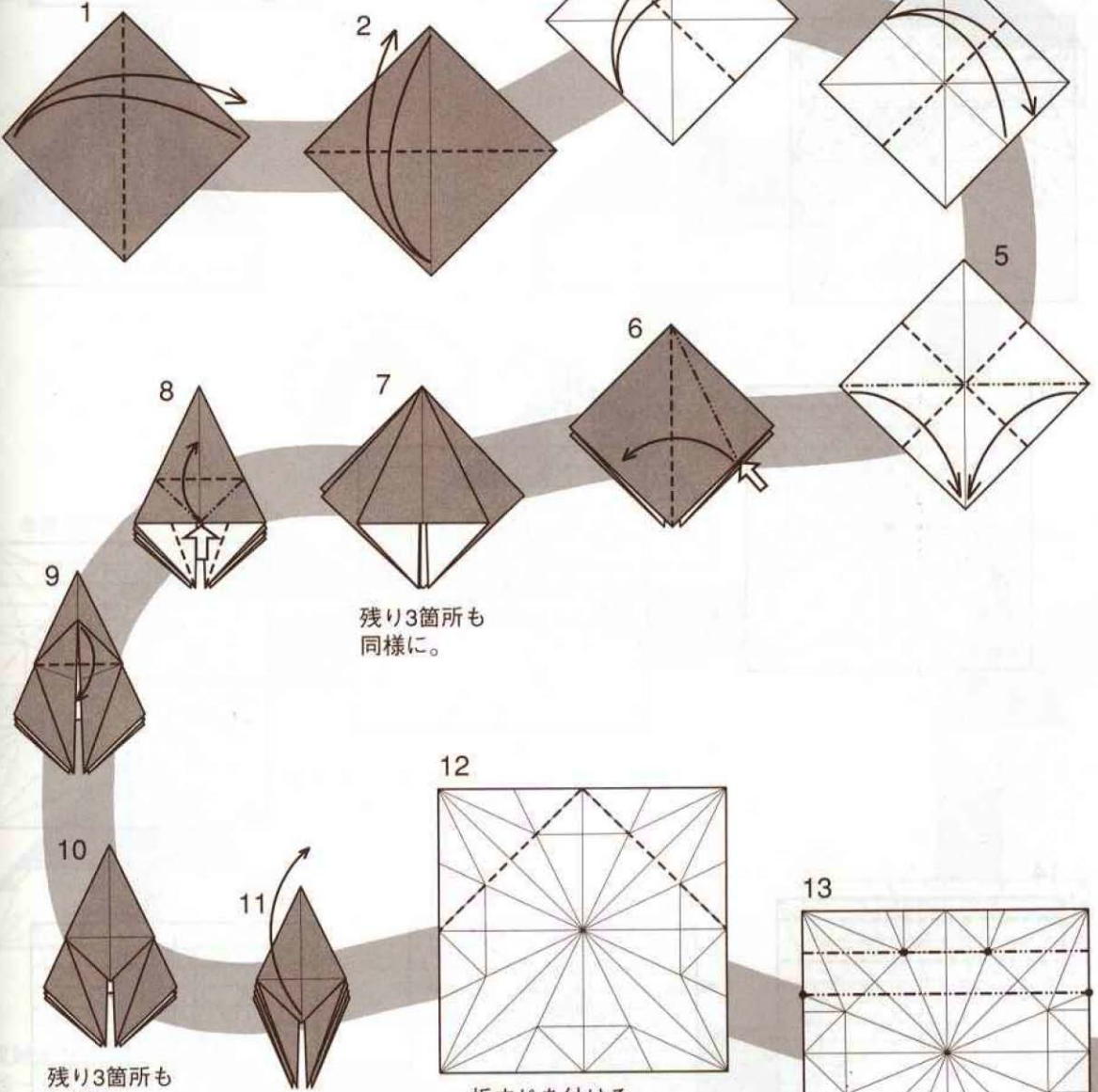
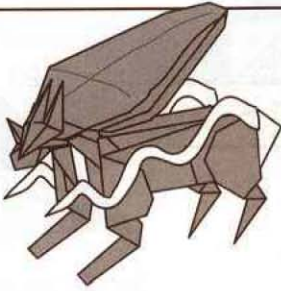

残り3箇所も同様に。

残り3箇所も同様に。

折すじを付ける。

**! WARNING**  
この折図は展開図折りの表現が使われています。

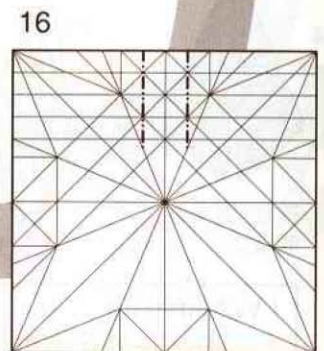
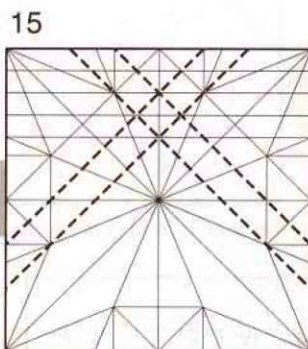
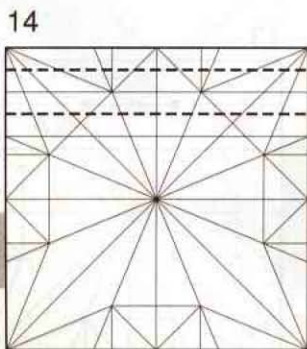
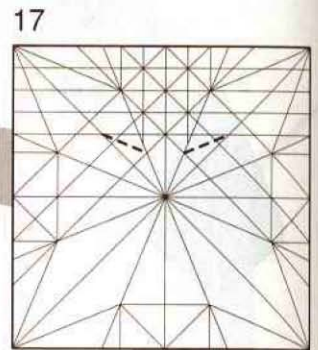
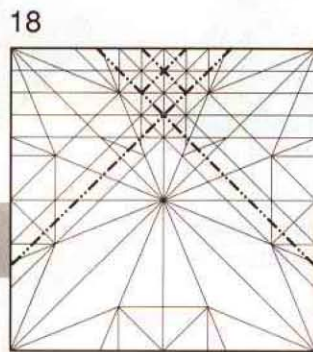
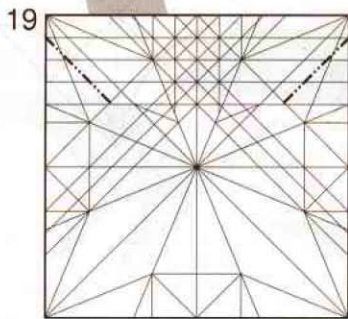
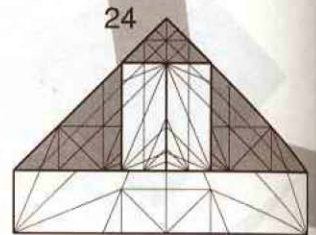
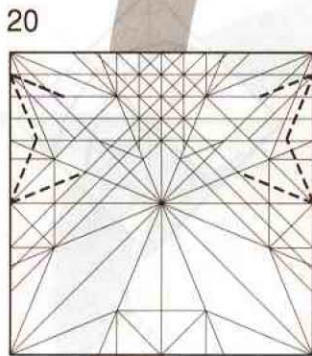
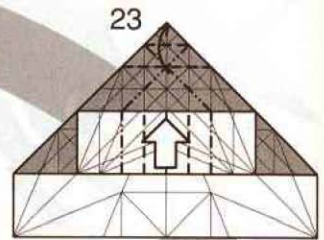
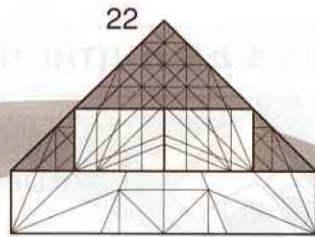
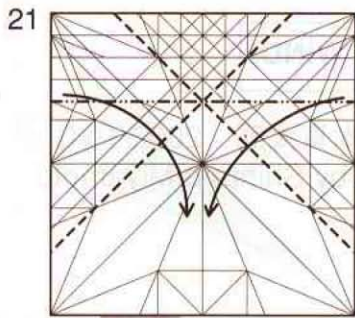

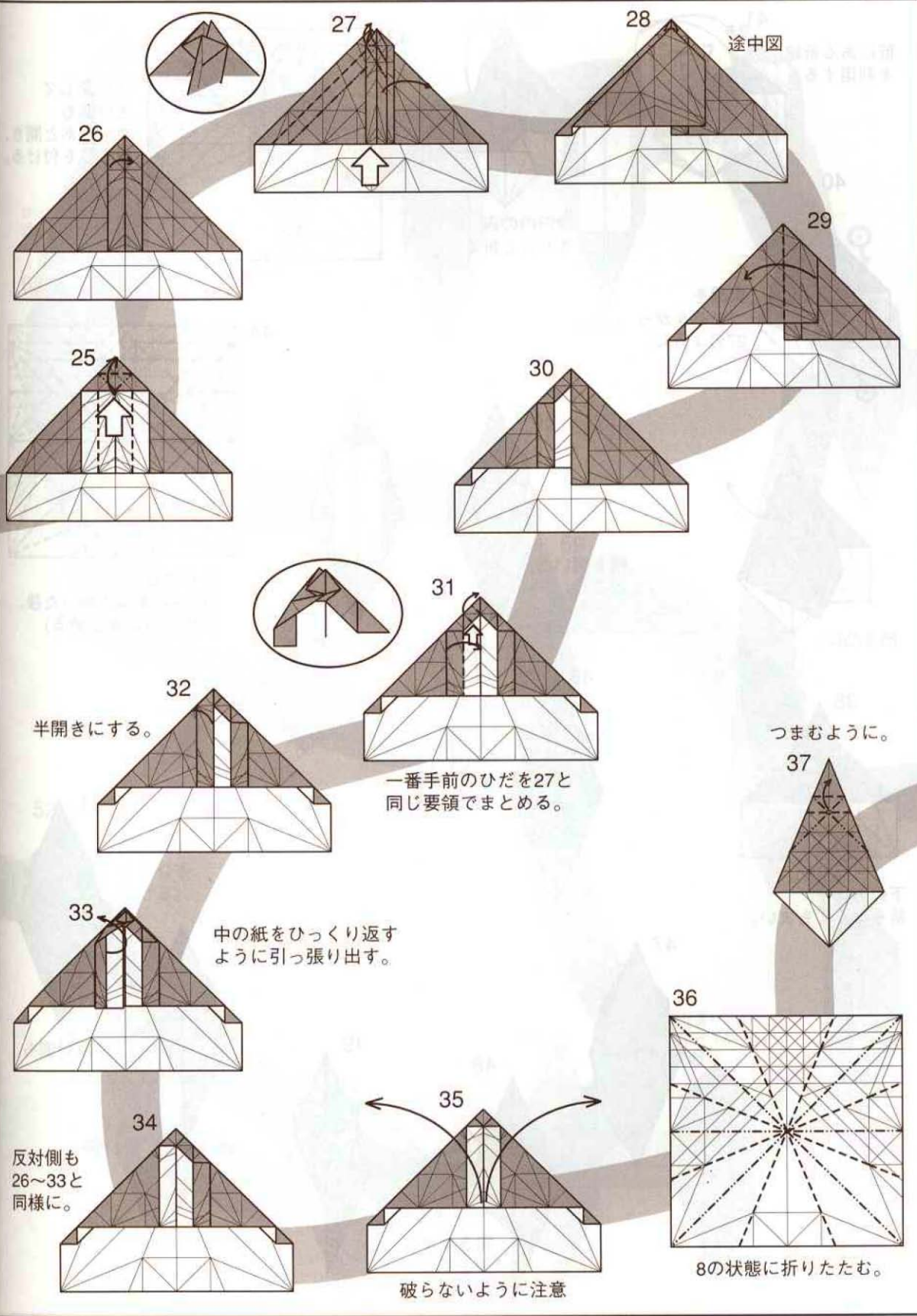

半開きにする。

途中図

一番手前のひだを27と同じ要領でまとめる。

中の紙をひっくり返すように引っ張り出す。

つまむように。

反対側も26~33と同様に。

破らないように注意

8の状態に折りたたむ。



既にある折線  
を利用する。

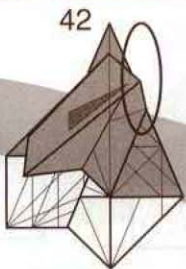

楕円内の  
みきちんと折る。

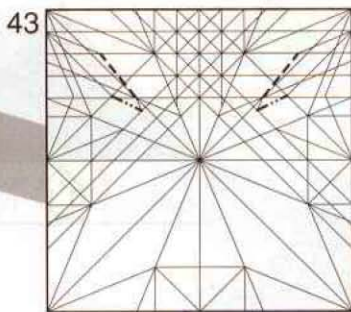

38に戻して  
反対側も  
やったあと開き、  
折すじを付ける。

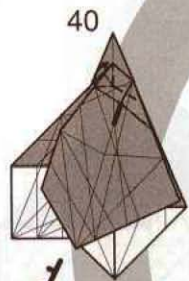

40

太線をつまみながら  
27のように。

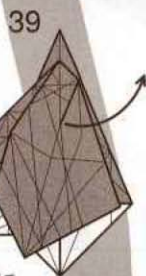

39

凹を凸に。



45

横を開いた  
ところ

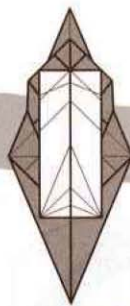

正面

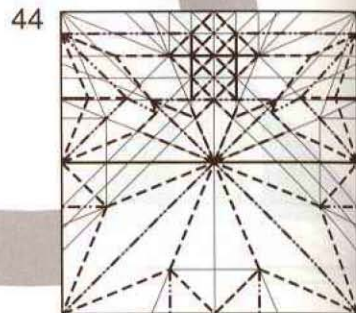

44

折り畳む。  
(38~42を両方やった後、  
28のようにまとめる)

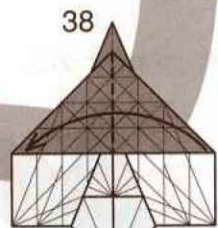

38

下の方は  
折らなくてもよい。



46

ひっくり  
返ってます。

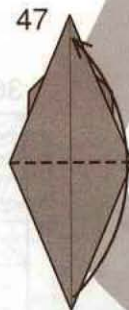

47

48



開きながら  
つぶす。



49

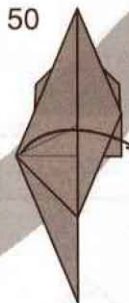

50



51

反対側も



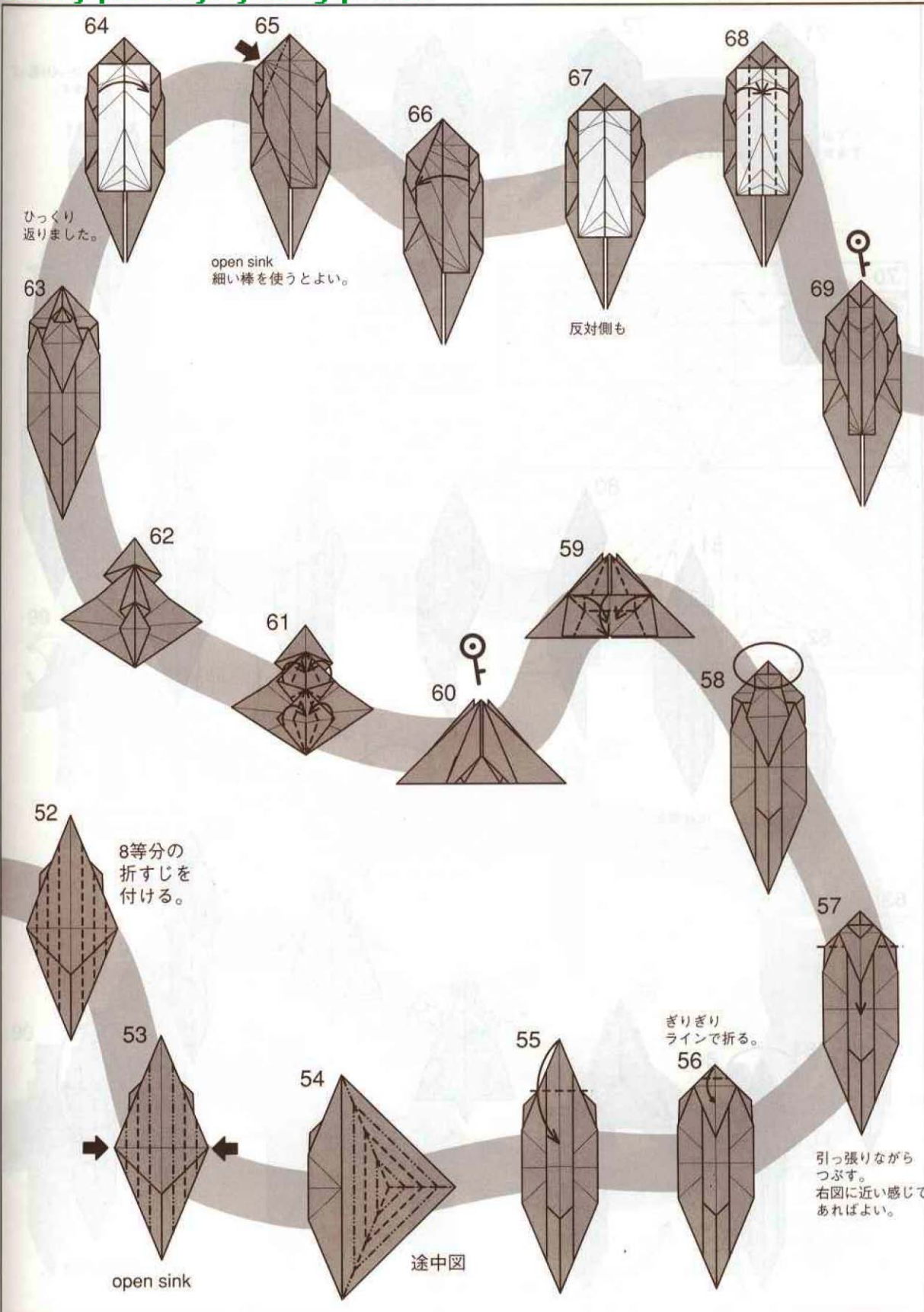

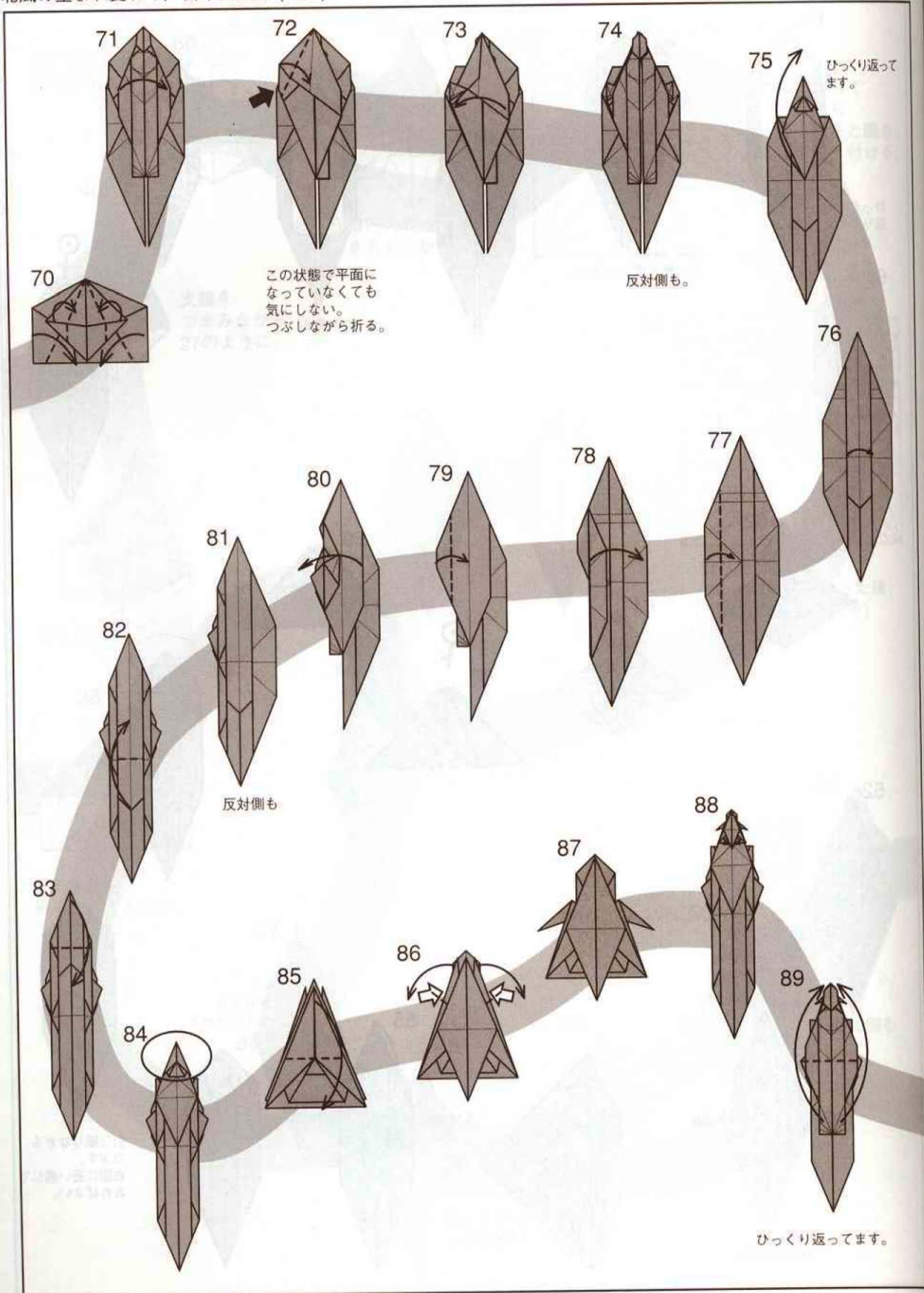

この状態で平面になっても気にしない。つぶしながら折る。

反対側も。

ひっくり返ります。

反対側も

ひっくり返ります。

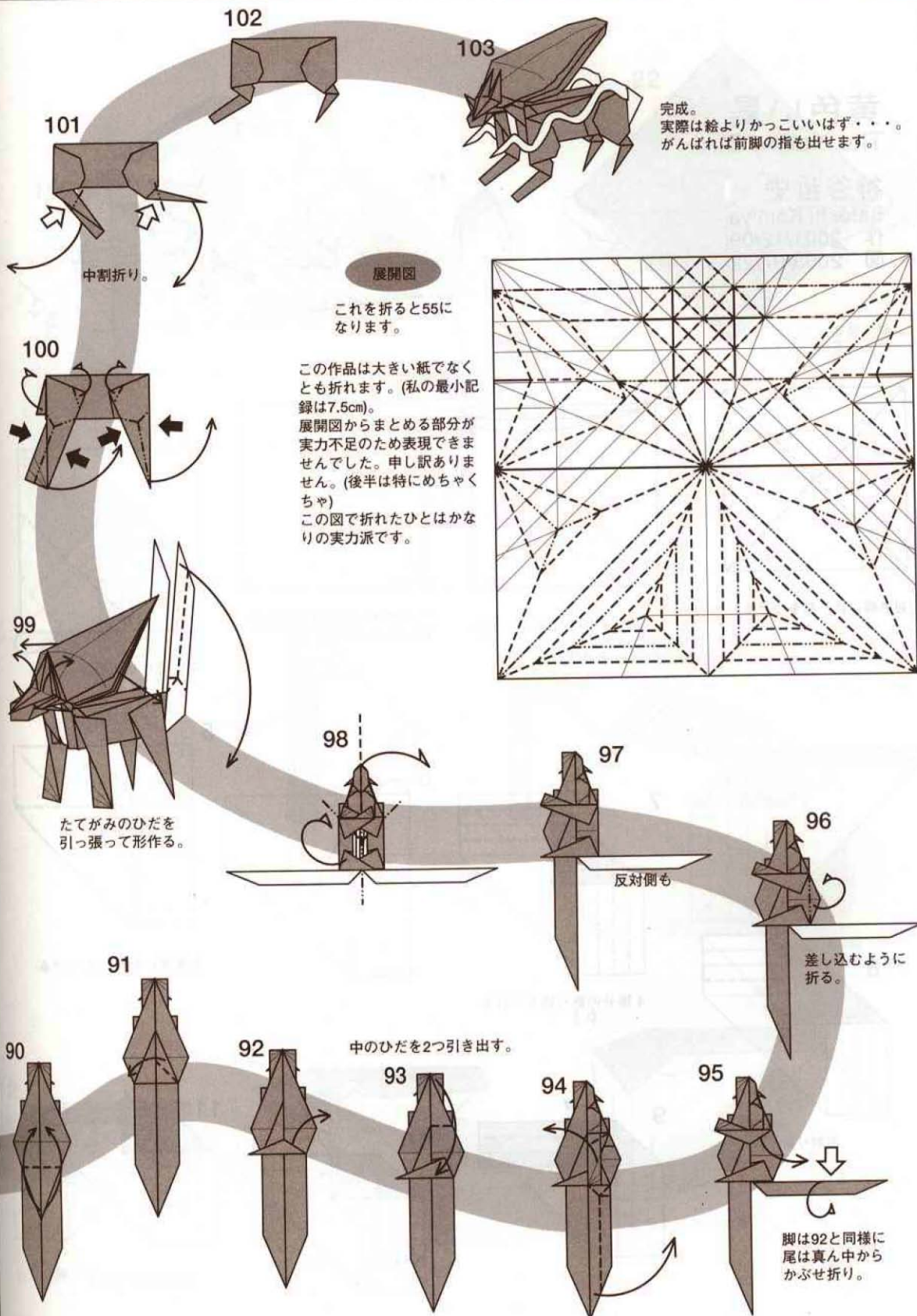

完成。  
 実際は絵よりかっこいいはず・・・。  
 がんばれば前脚の指も出せます。

**展開図**

これを折ると55になります。

この作品は大きい紙でなくとも折れます。(私の最小記録は7.5cm)。  
 展開図からまとめる部分が出来不足のため表現できませんでした。申し訳ありません。(後半は特にめちゃくちゃ)  
 この図で折れたひとはかなりの実力派です。

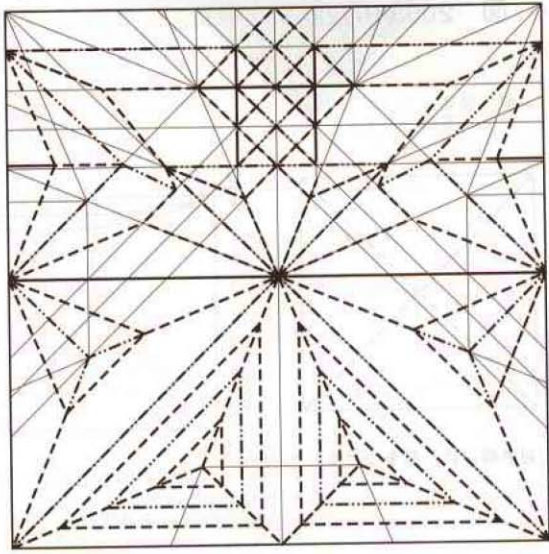

たてがみのひだを引っ張って形作る。

反対側も

差し込むように折る。

中のひだを2つ引き出す。

脚は92と同様に尾は真ん中からかぶせ折り。

# 黄色い鳥 The Yellow Bird

神谷哲史  
Satoshi Kamiya  
作 2001/12/09  
図 2003/07/22

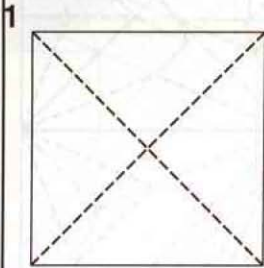
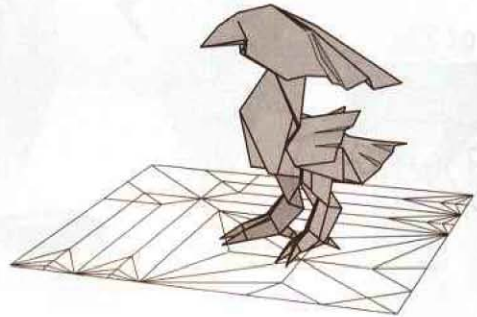

対角線に折り筋をつける

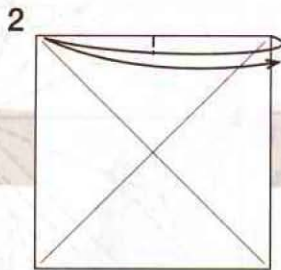

2/1 の印をつける

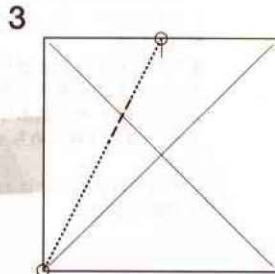

○を基準に対角線付近のみ折り筋をつける

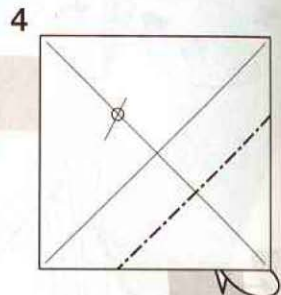

○に合わせて裏側に折る

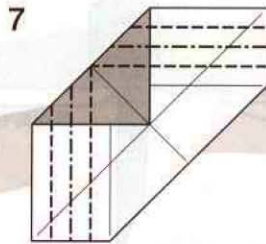

4等分の折り筋をつける

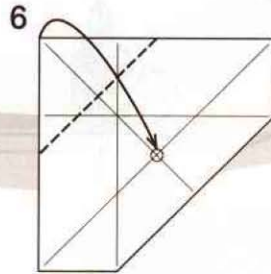

○を基準に折り筋をつける

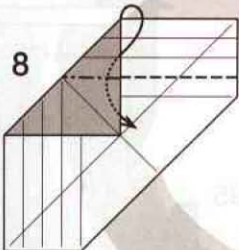
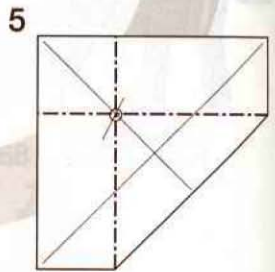

中割り折り

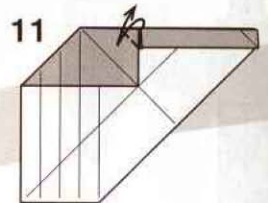
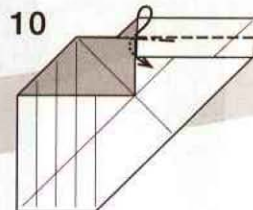
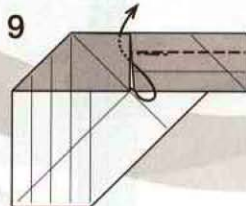

折り筋をつける

[www.japaoburajirujin.blogspot.com](http://www.japaoburajirujin.blogspot.com)

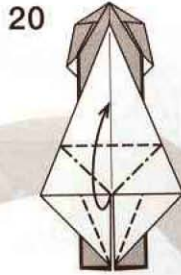

カエルの基本形のように折る

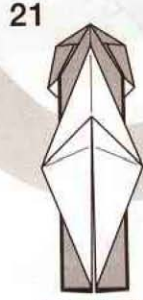

白い部分を開く

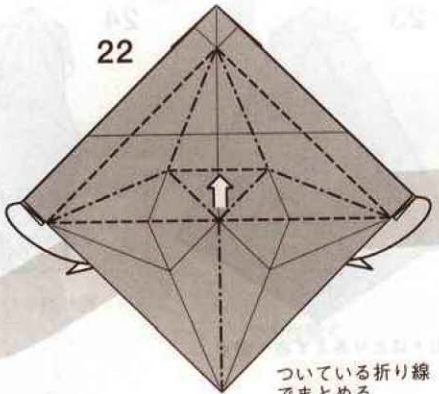

ついている折り線でまとめる

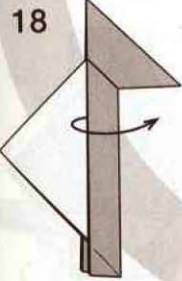
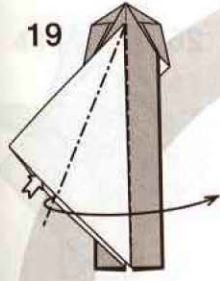

ヒダを開く

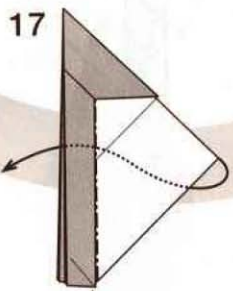

白い部分を中割り折り

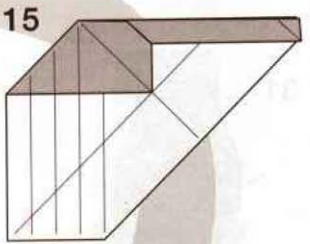
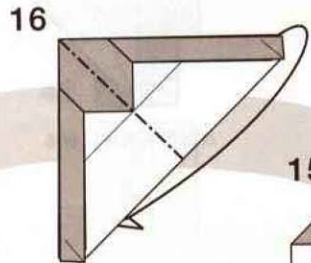

反対側も同じ

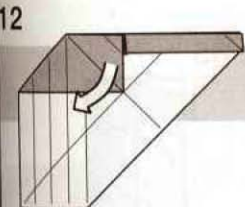

ヒダを開いて……

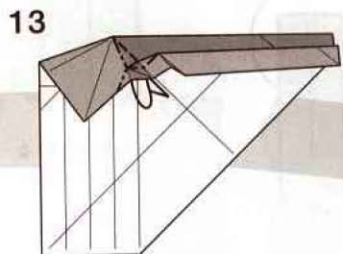

縦のヒダを開いてつぶす様にして……

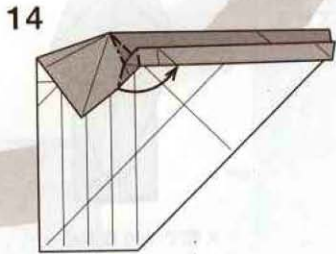

平らにまとめる

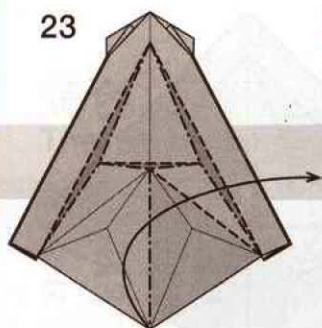

カドはとりあえず右へ倒す

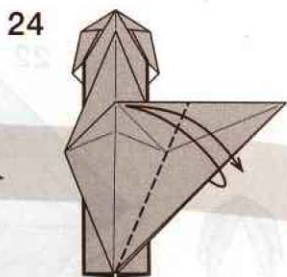

折り筋をつける

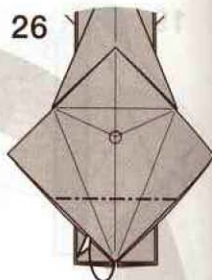
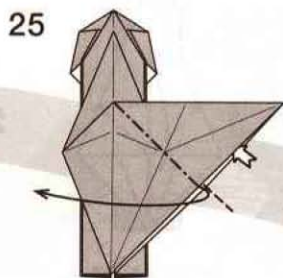

裏側に折り込む

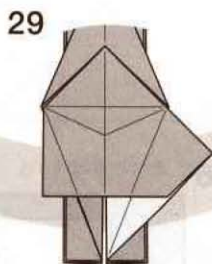
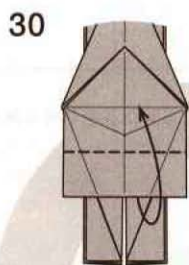

反対側も同様に折る

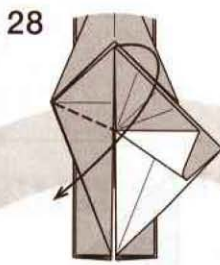

戻す。

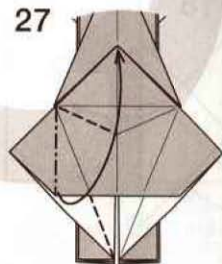

カドを引っ張り上げて……

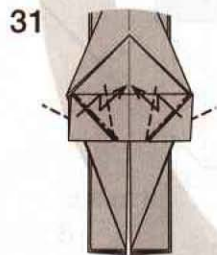

ずらすようにして折る



X軸で180度回転

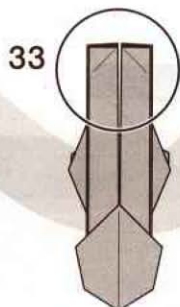

上のほうを拡大

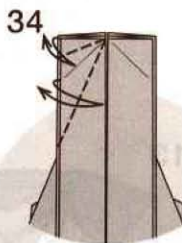

折り筋をつける

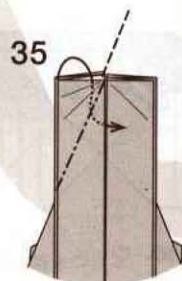

中割り折り

47

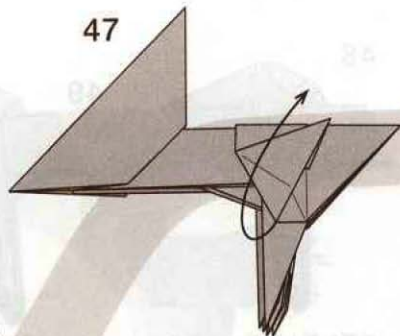

1枚開く

46

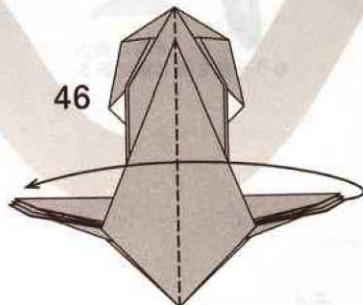

45

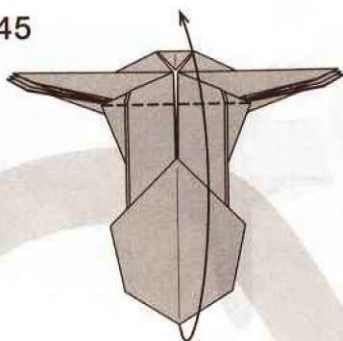

44

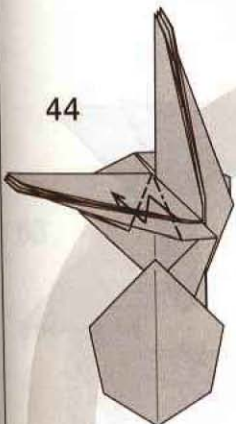

ついている線で  
段折りするように折りたむ

[www.japaoburajirujin.blogspot.com](http://www.japaoburajirujin.blogspot.com)

43

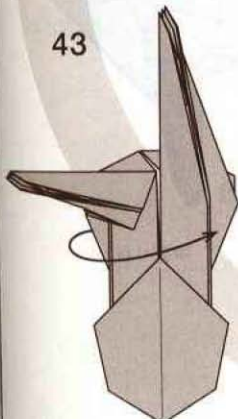

ヒダ3枚を反対側へ引き出す

42

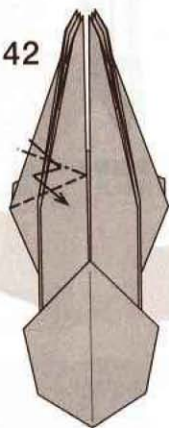

段折り

41

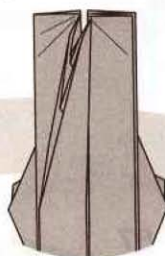

他の3ヶ所も  
34-40と同様に折る

40

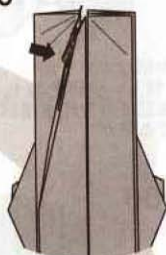

先の部分もしずめ折り  
(opensink)

39



しずめ折り  
(opensink)

38

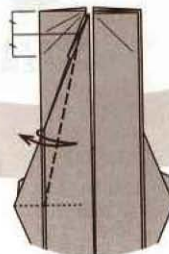

折り筋をつける

37



中割り折り

36



中割り折り

48

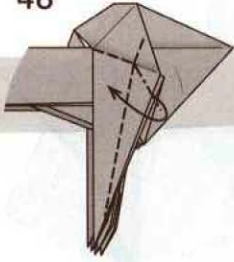

中割り折りするようにして  
脚を細くする

49

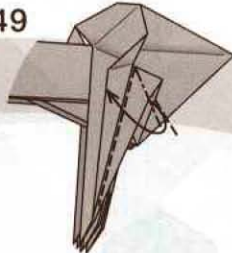

もう一枚も同じ様に折る

50

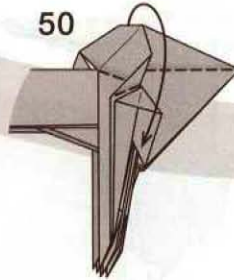

閉じる

51

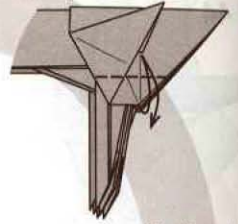

折り筋をつける

[www.japaoburajirujin.blogspot.com](http://www.japaoburajirujin.blogspot.com)

54

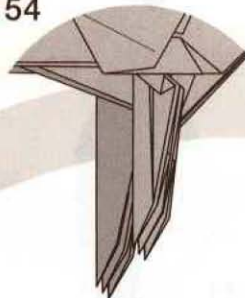

先端をさらに拡大

53

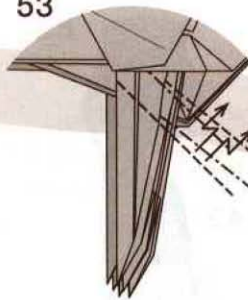

中割り折り 2回

52

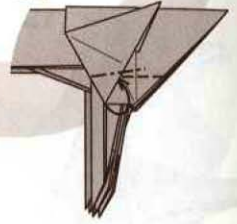

中割り折り

55

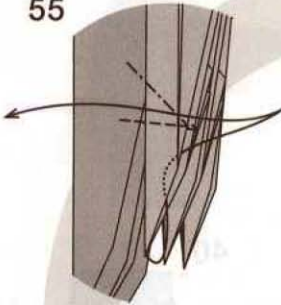

中割り折り 2回  
(怪しい矢印その1。  
毎回違う矢印を描いて  
る気が……)

57

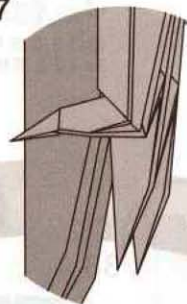

奥のカドも  
55-56 と同様に折る

56

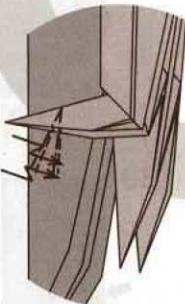

段折りするよう  
かぶせ折り

58

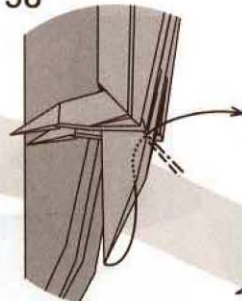

中割り折り

59

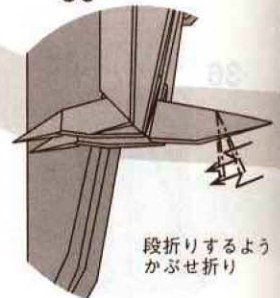

段折りするよう  
かぶせ折り



64

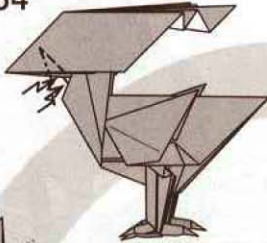

段折りするよう  
かぶせ折り

65

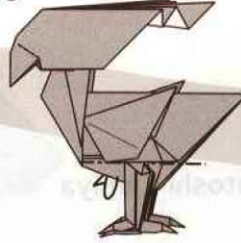

内側へ折る

66

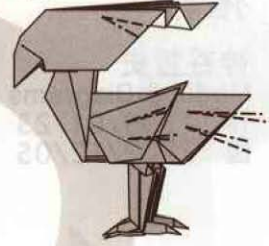

各部にヒダを入れる

[www.japaoburajirujin.blogspot.com](http://www.japaoburajirujin.blogspot.com)

63

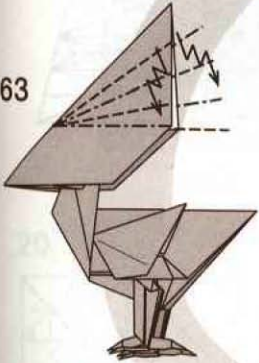

11.25度で段折り

67



尾の形を整える

62

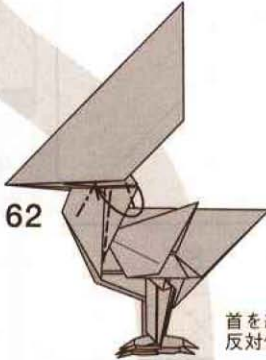

首を細く折る  
反対側も同じ

68

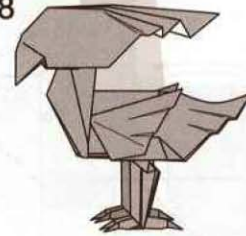

完成

61

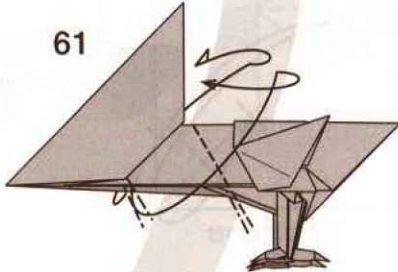

かぶせ折り2回  
(怪しい矢印その2。  
かぶせ折りの矢印をつな  
げただけ。個人的にこん  
な感じの動きをすと思  
うのですが如何?)

60



拡大終了

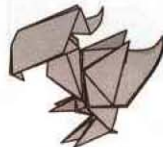

有名RPGより。  
元の題材は2Dの頃のアイコン状の  
物で(左図)、この作品はそれをさら  
に折り込んだものです。

[www.japaoburajirujin.blogspot.com](http://www.japaoburajirujin.blogspot.com)

# 猪神

神谷哲史

Model & Diagrams by Satoshi Kamiya

作 1999/01/23

図 2002/12/05

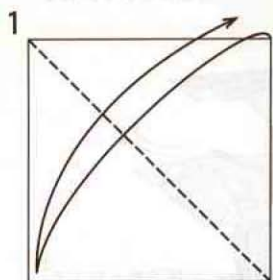
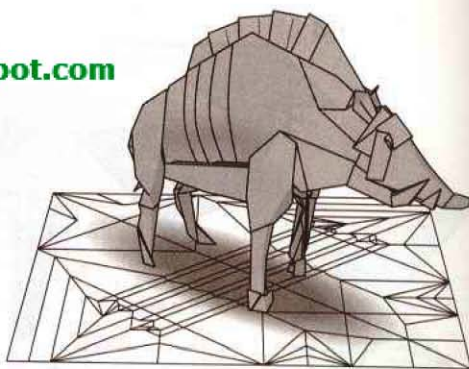

折り筋をつける

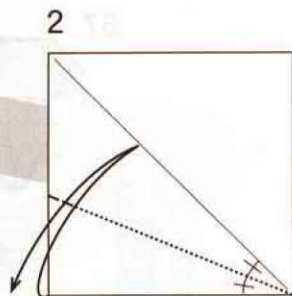

辺に印をつける

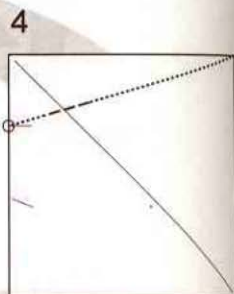
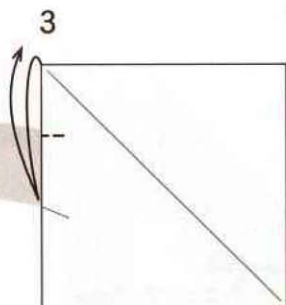

対角線のあたりに折り筋をつける

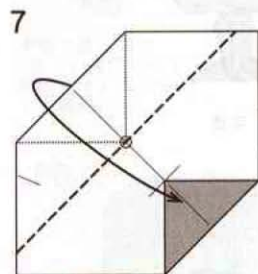

裏側にあるカドを基準に折る

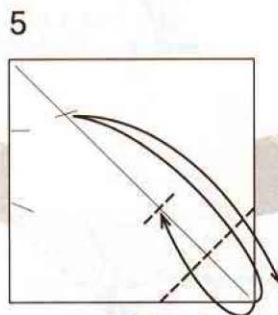
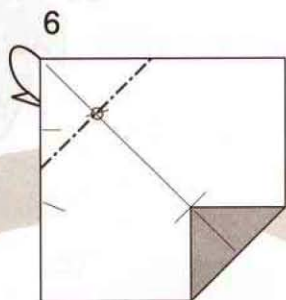

1/2 で印をつけ  
1/4 で折る

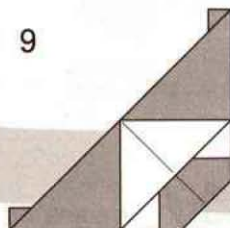
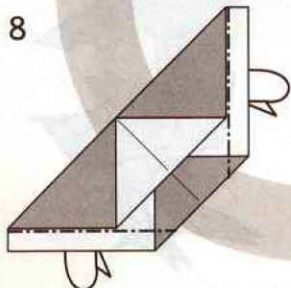

開く

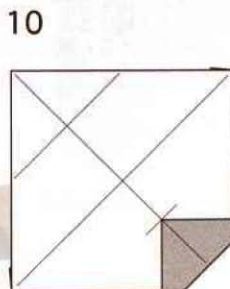

裏返す

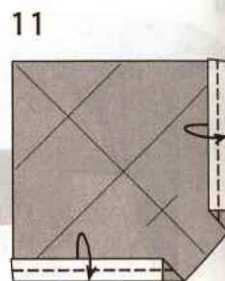

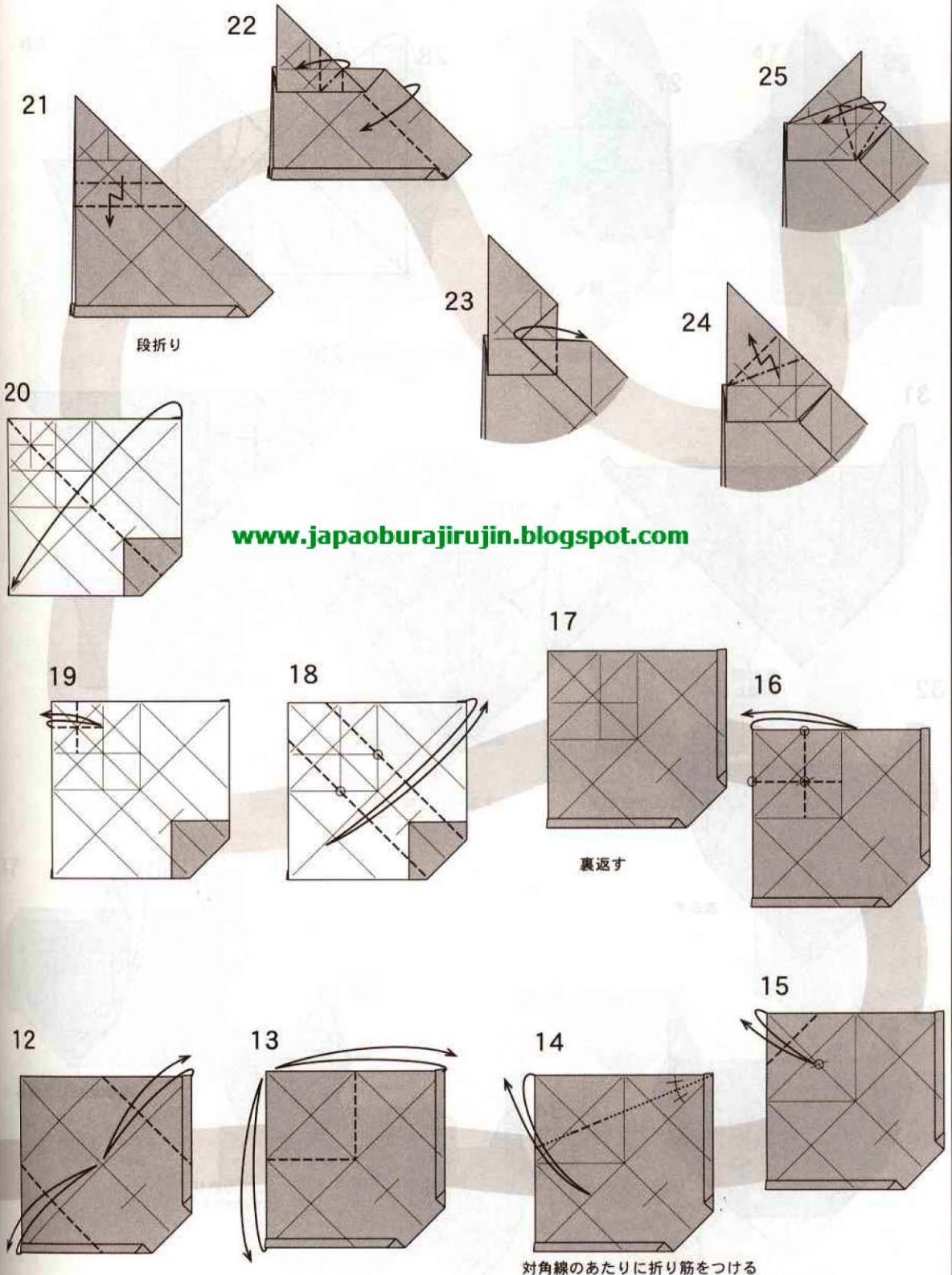

[www.japaoburajirujin.blogspot.com](http://www.japaoburajirujin.blogspot.com)

対角線のあたりに折り筋をつける

26

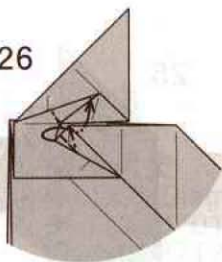

27

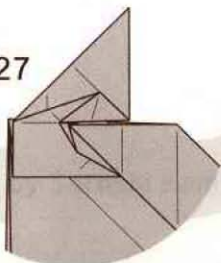

28

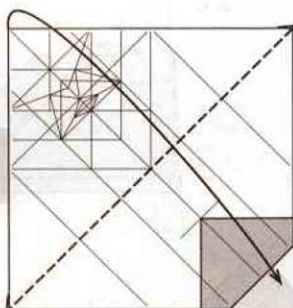

開く

[www.japaoburajirujin.blogspot.com](http://www.japaoburajirujin.blogspot.com)

31

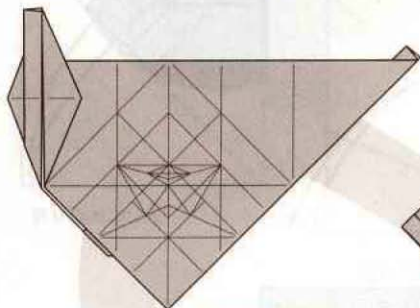

29

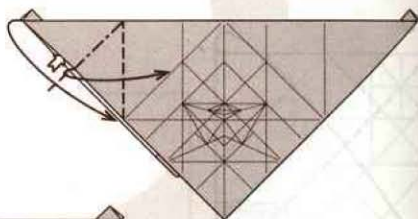

30

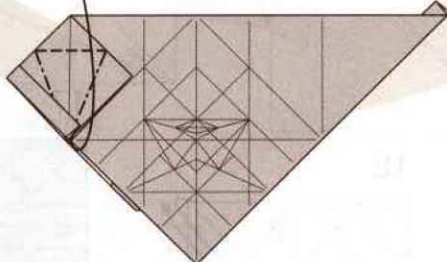

32

反対側も 29-30 と  
同様に折る

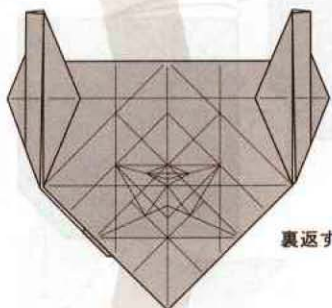

裏返す

33

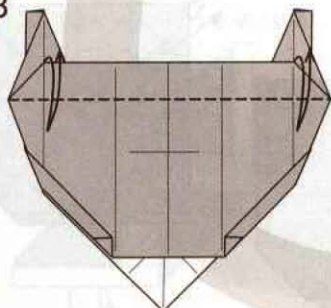

折り筋をつける

35

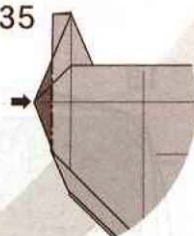

しずめ折り  
opensink

34

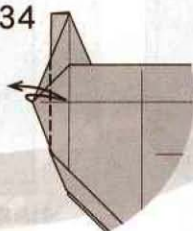

折り筋をつける

36

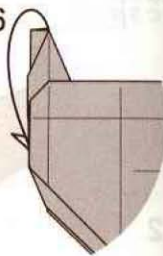

裏側に折り下げる

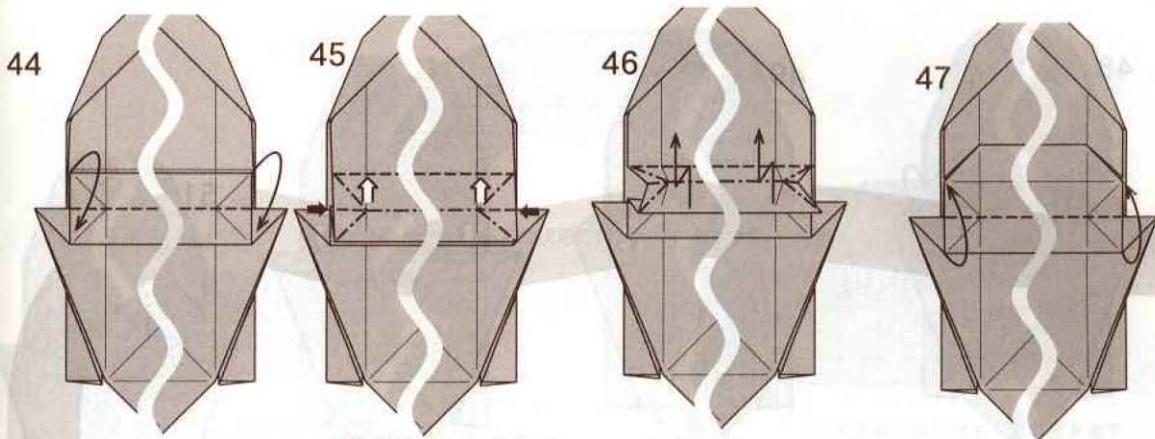

紙を突き出すようにして  
段折り状に折り畳む

途中図

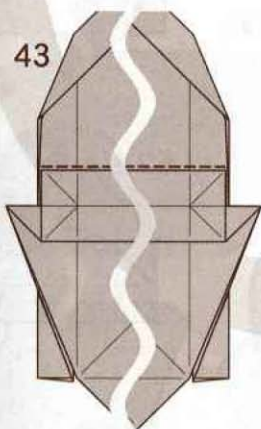

上の辺にそって  
折り筋をつける

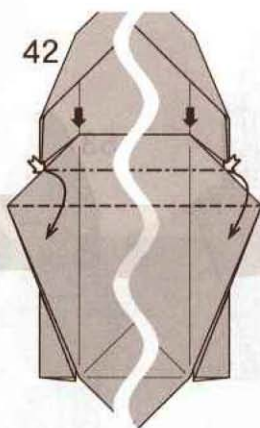

開いてつぶす

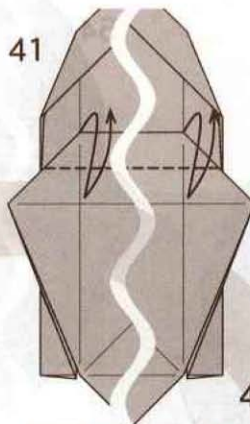

1/2 で折り筋をつける

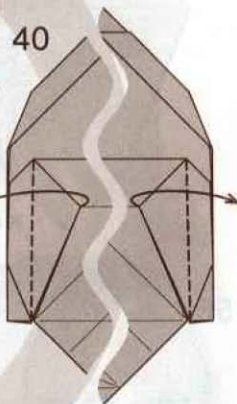

両側を拡大  
裏返す

[www.japaoburajirujin.blogspot.com](http://www.japaoburajirujin.blogspot.com)

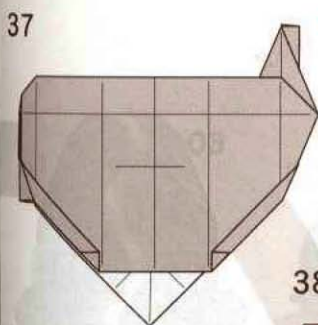

右側も 34-36  
と同様に折る

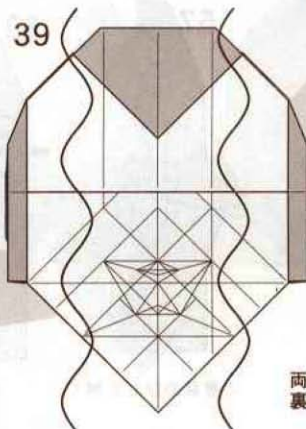
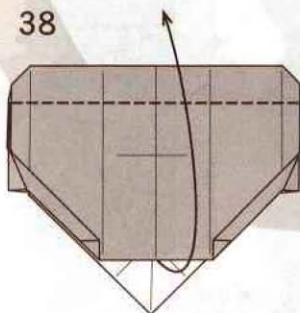

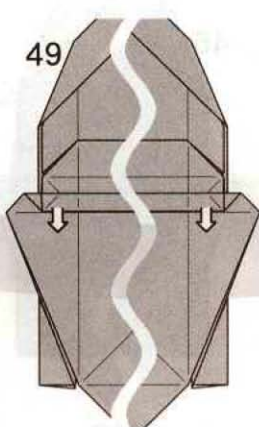
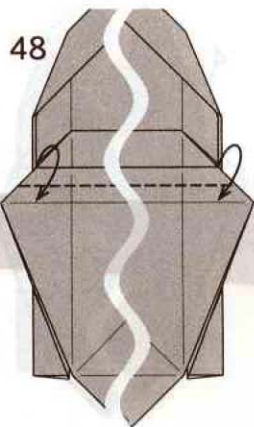

半開状にする

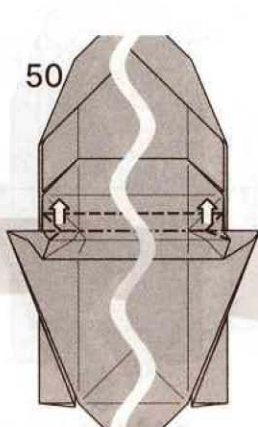

45と同様に  
段折り状に折り畳む

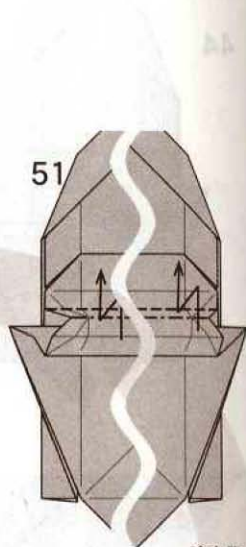

途中図

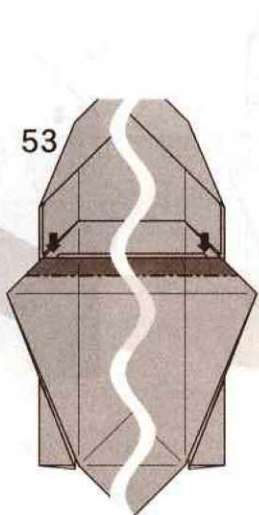
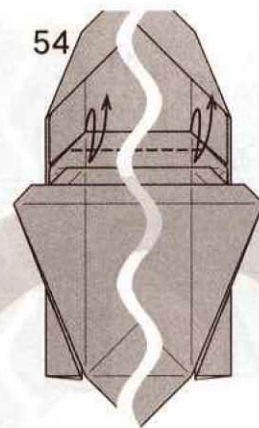

濃い部分を押し込む

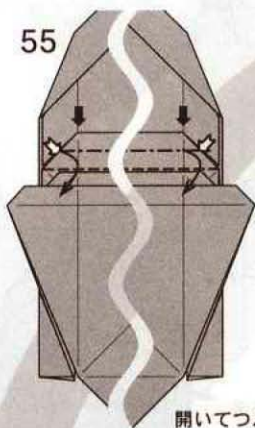
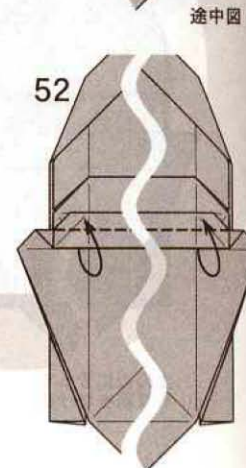

開いてつぶす

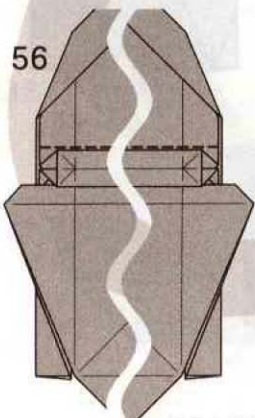

辺に合わせて  
折り筋をつける

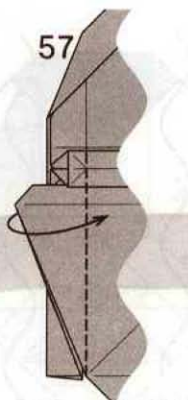

2番目のひだを開く

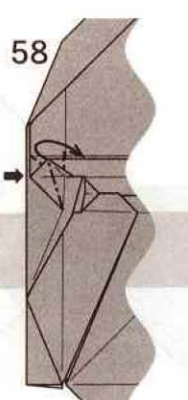

56でつけた折り筋と  
カドを基準につぶす

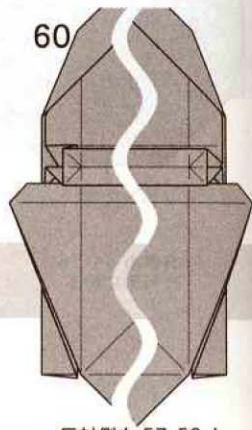
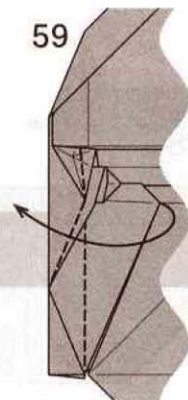

反対側も57-59と  
同様に折る

69

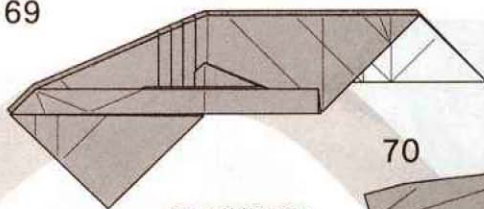

70

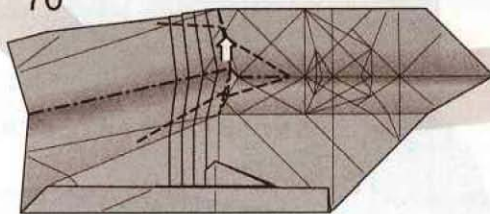

67の状態に開く

76を目安に中央部を下から突き出す

68

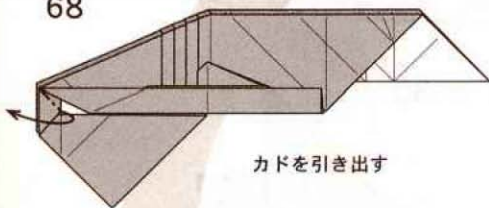

カドを引き出す

67

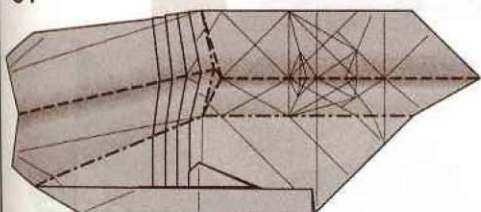

途中図

[www.japaoburajirujin.blogspot.com](http://www.japaoburajirujin.blogspot.com)

66

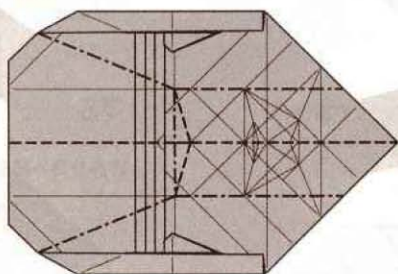

ついている折り筋で一気に折り畳む

65

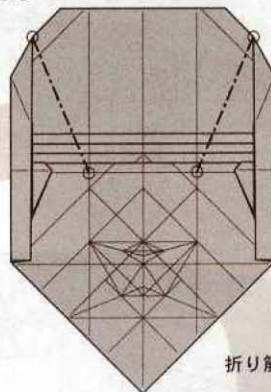

折り筋をつける

61

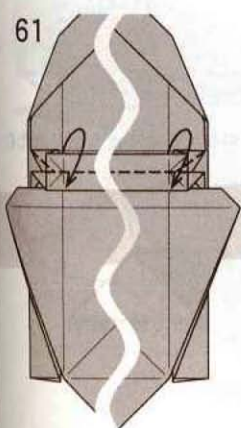

62

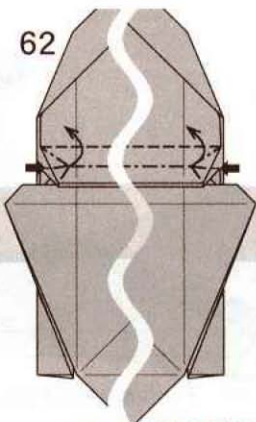

63

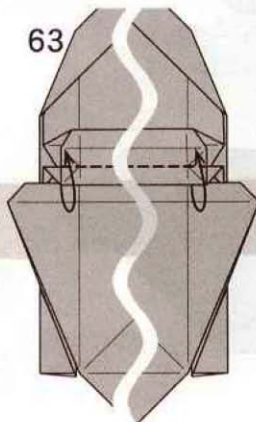

64

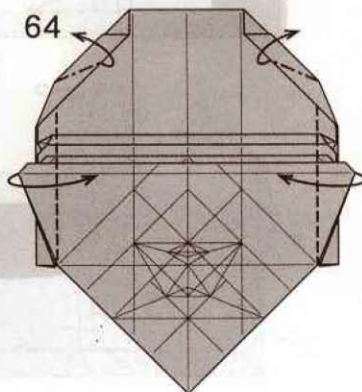

ついている折り目を使用し  
45、50と同様に  
段折り状に折り畳む

71

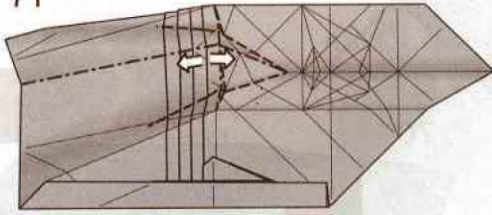

ひだを少し引き出す  
左側の谷折り線をずらして上手く吸収する

72

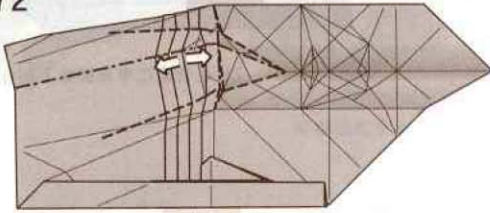

また

73

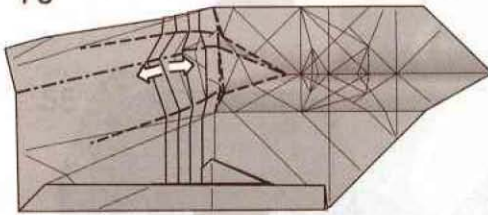

まだ

74

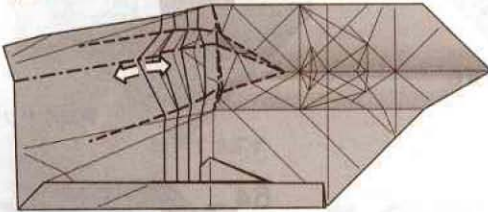

もう一つ

75

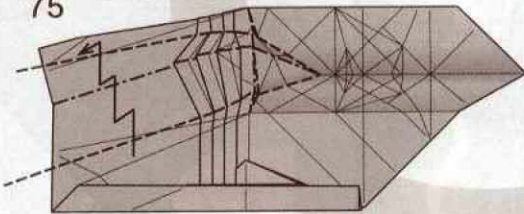

全体を折り畳む  
中央と左右の山が  
だいたい平行になるよう調整する

81

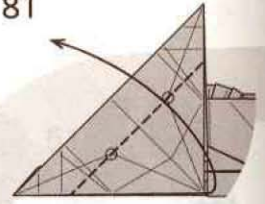

80

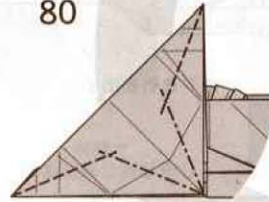

折り筋をつける

79

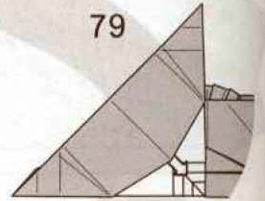

折り畳まれているカドを引き出す

78

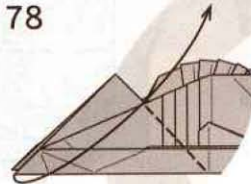

77

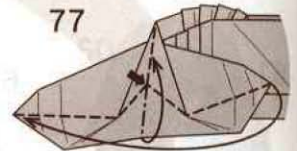

中割り折りするよう折りたたむ

76

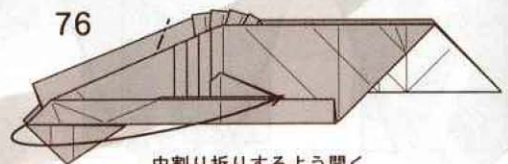

中割り折りするよう開く



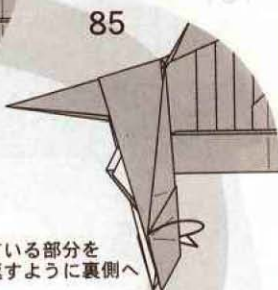
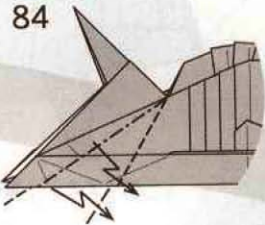
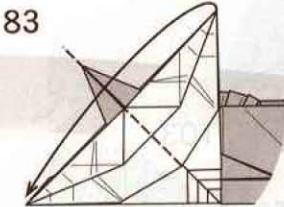
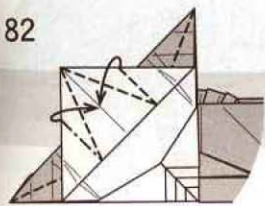

かぶさっている部分を  
ひっくり返すように裏側へ

[www.japaoburajirujin.blogspot.com](http://www.japaoburajirujin.blogspot.com)

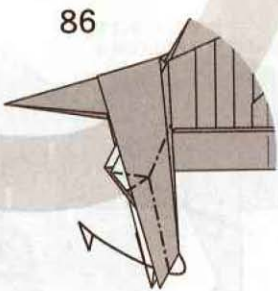
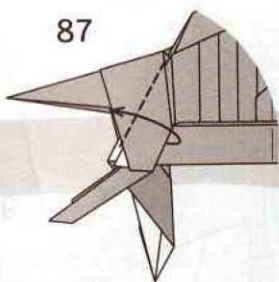
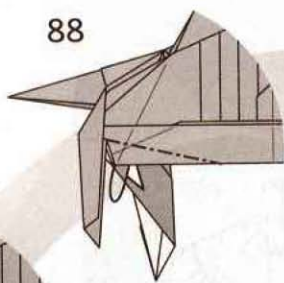

一端開き

裏側につまみ折り

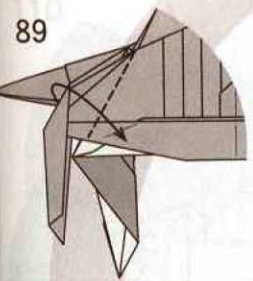

裏側へ折り込む

戻す

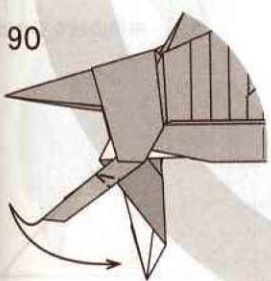

中割り折り 2回

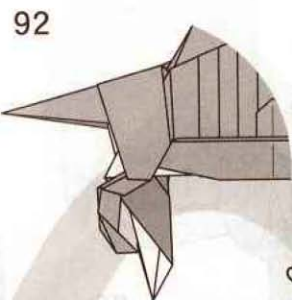

反対側も 85-91 と  
同様に折る

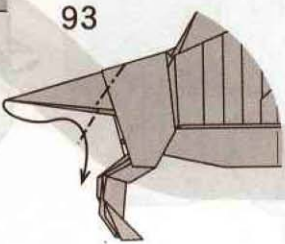
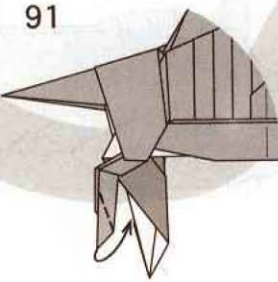

中割り折り



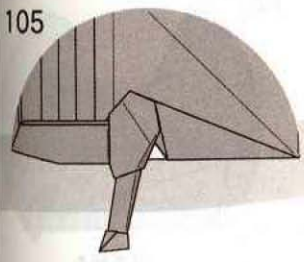

105

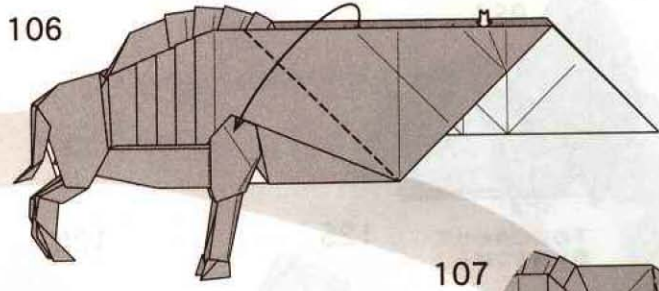

106

反対側も 96-104 と同様に折る

大きく開く

[www.japaoburajirujin.blogspot.com](http://www.japaoburajirujin.blogspot.com)

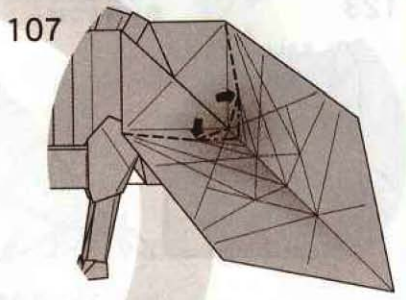

107

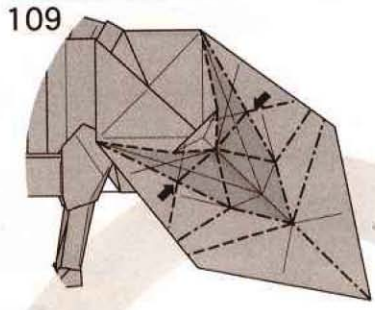

109

そのままついている線で折りたたむ

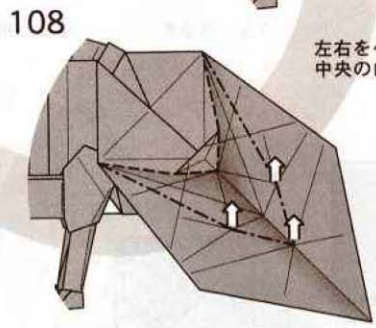

108

左右をへこませ  
中央の山折り線をしっかり折る

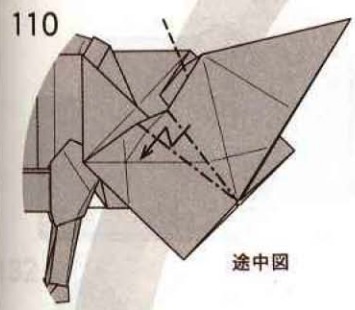

110

途中図

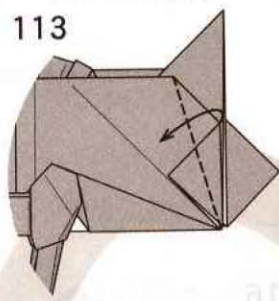

113

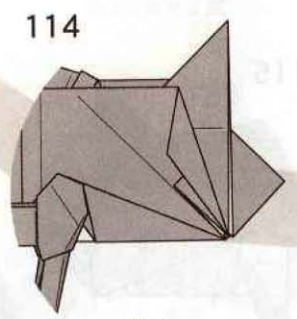

114

開く

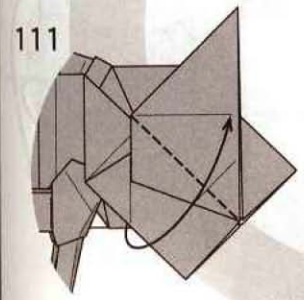

111

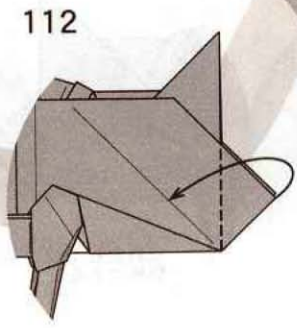

112

124

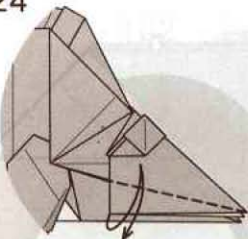

下の辺に合わせて  
折り筋をつける

127

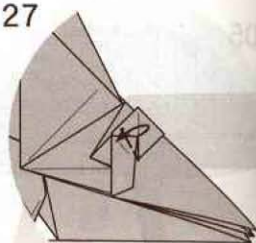

目を折る

123

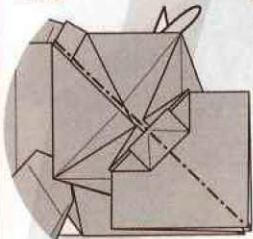

125

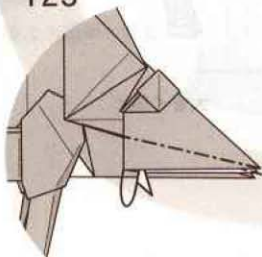

126

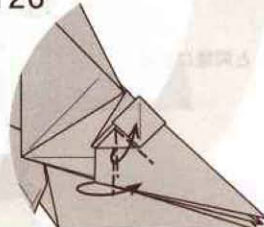

中割り折り

[www.japaoburajirujin.blogspot.com](http://www.japaoburajirujin.blogspot.com)

122

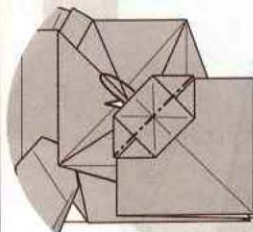

121

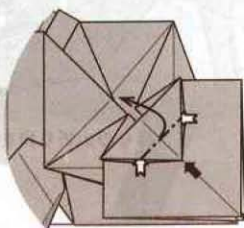

120

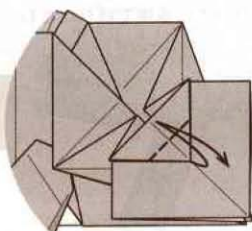

カドを開いてつぶす

119

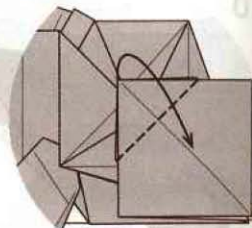

115

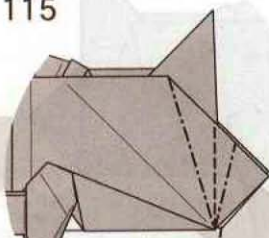

中割り折り 3回

116

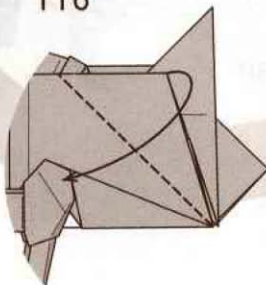

117



反対側も 112-115 と  
同様に折る

118

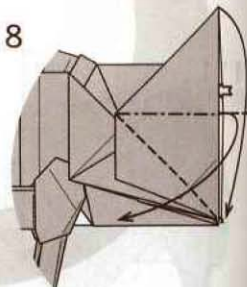

[www.japaoburajirujin.blogspot.com](http://www.japaoburajirujin.blogspot.com)

128

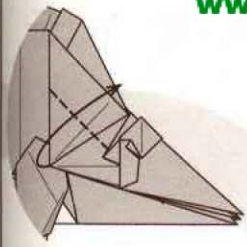

139

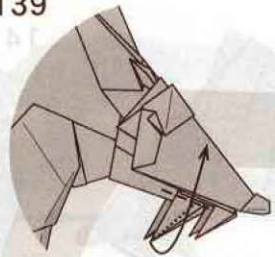

カドを折り上げる

129

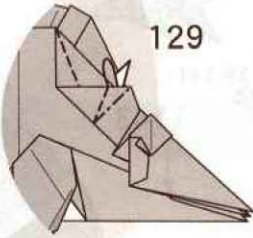

138

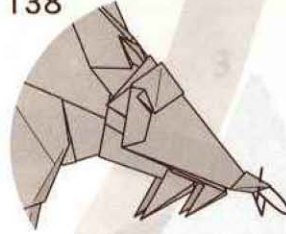

先を折り込む

130

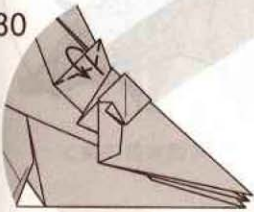

耳をつまむように折る

137

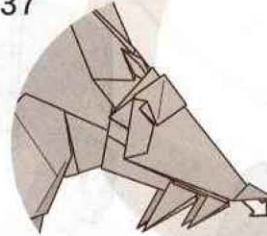

中側の紙を引き出す

131

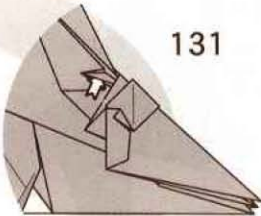

136

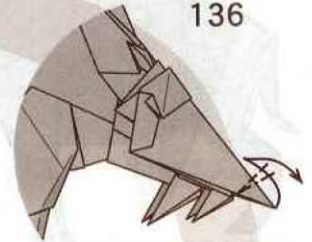

かぶせ折り2回

132

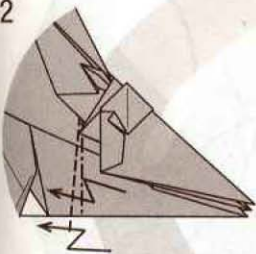

両側段折り

耳を開く  
反対側も 128-131 と同様折る

135

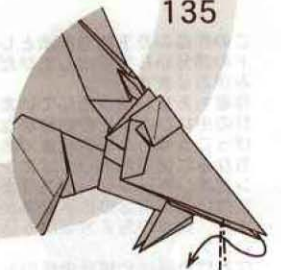

中割り折り

133

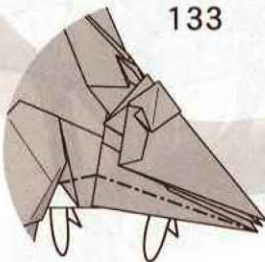

中側へ折り込む

134

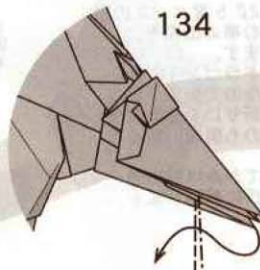

中割り折り

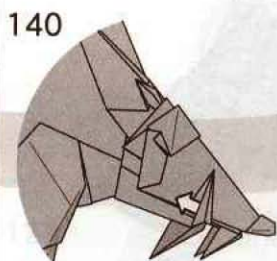

140  
中側の紙を引き出す

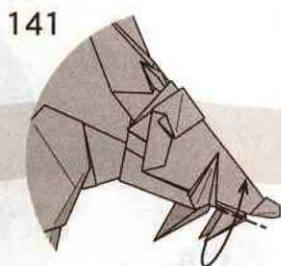

141

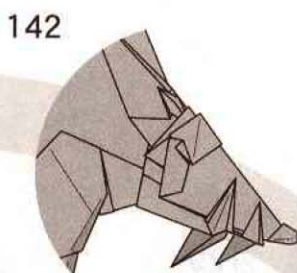

142

反対側も 139-141  
と同様に折る

143

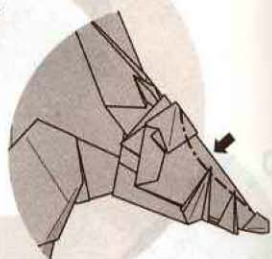

[www.japaoburajirujin.blogspot.com](http://www.japaoburajirujin.blogspot.com)

144

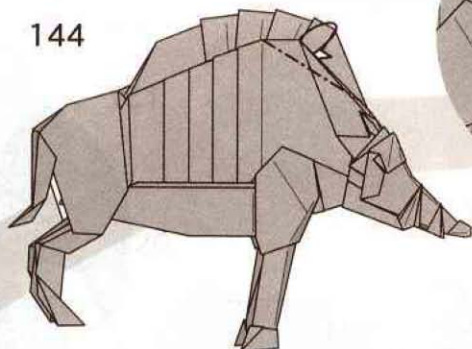

145

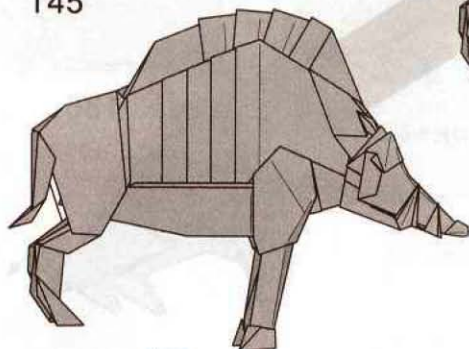

完成

この作品の目玉的な技法として、鶴の基本形の小さいカドの部分から折り出したひだで表現した肋骨からたてがみがあります。

作者もあまり使用はしていませんが、22.5度ベースの設計の中にひだを比較的無理なく組み込む事の出来る、けっこう強力な表現技法であると思います。

ちなみに使用例としてはエンシェントドラゴンTVチャンピオンバージョンがあります。腹部なのであまり目立たない上に折るのに手間がかかる上に折りにくくなりますが、興味のある方は組み込んでみるのも面白いかと思えます。

なお肋骨部は北條高史氏のトラを、たてがみは故吉野一生氏の技法をヒントになりました。両氏に感謝します。

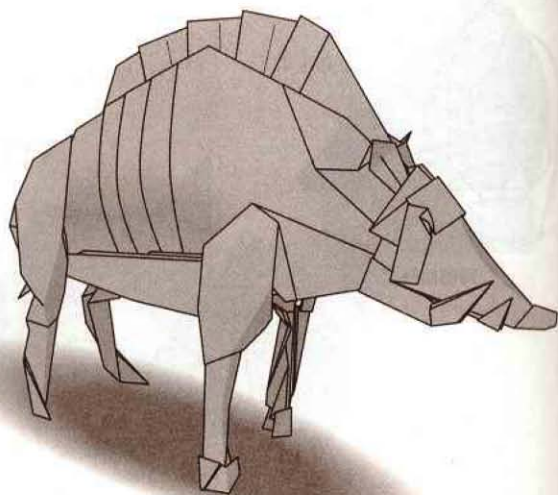

# ティラノサウルス

## TYRANNOSAURUS

創作・作図：木村哲夫  
(2003.02)

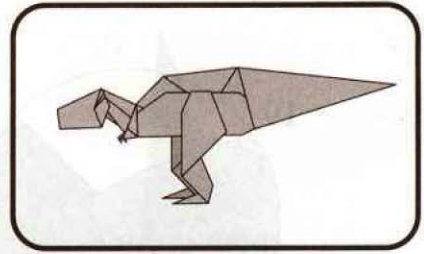

[www.japaoburajirujin.blogspot.com](http://www.japaoburajirujin.blogspot.com)

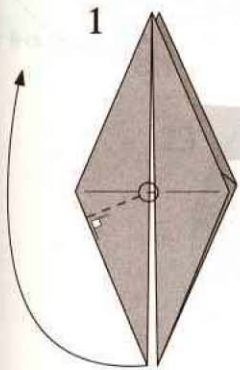

<鶴の基本型>

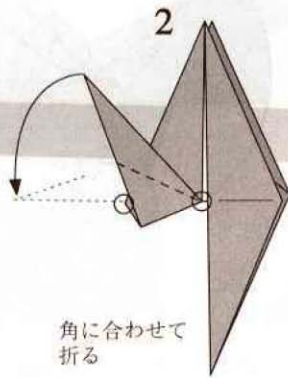

角に合わせて折る

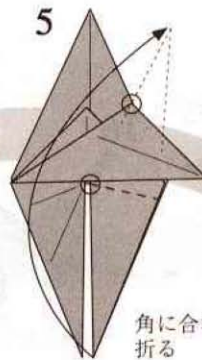
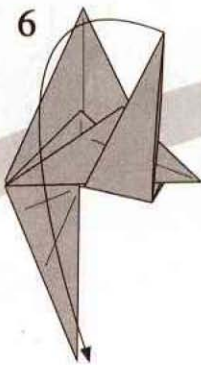
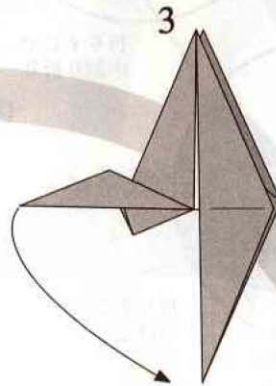

角に合わせて折る

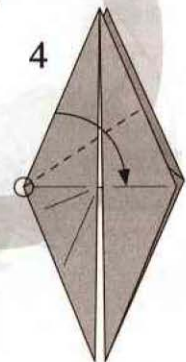

折りすじに合わせて折る

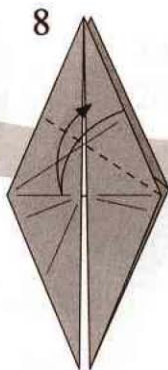
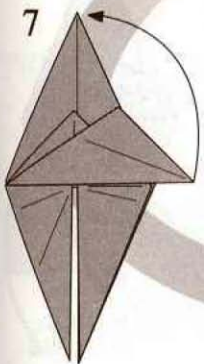

折りすじをつける

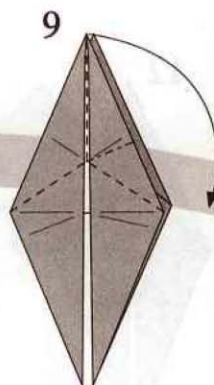

つまみ折り

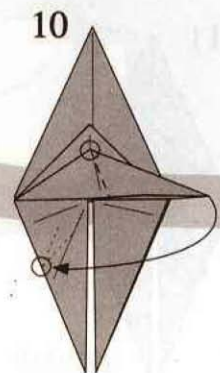

紙のふちにに合わせて折る

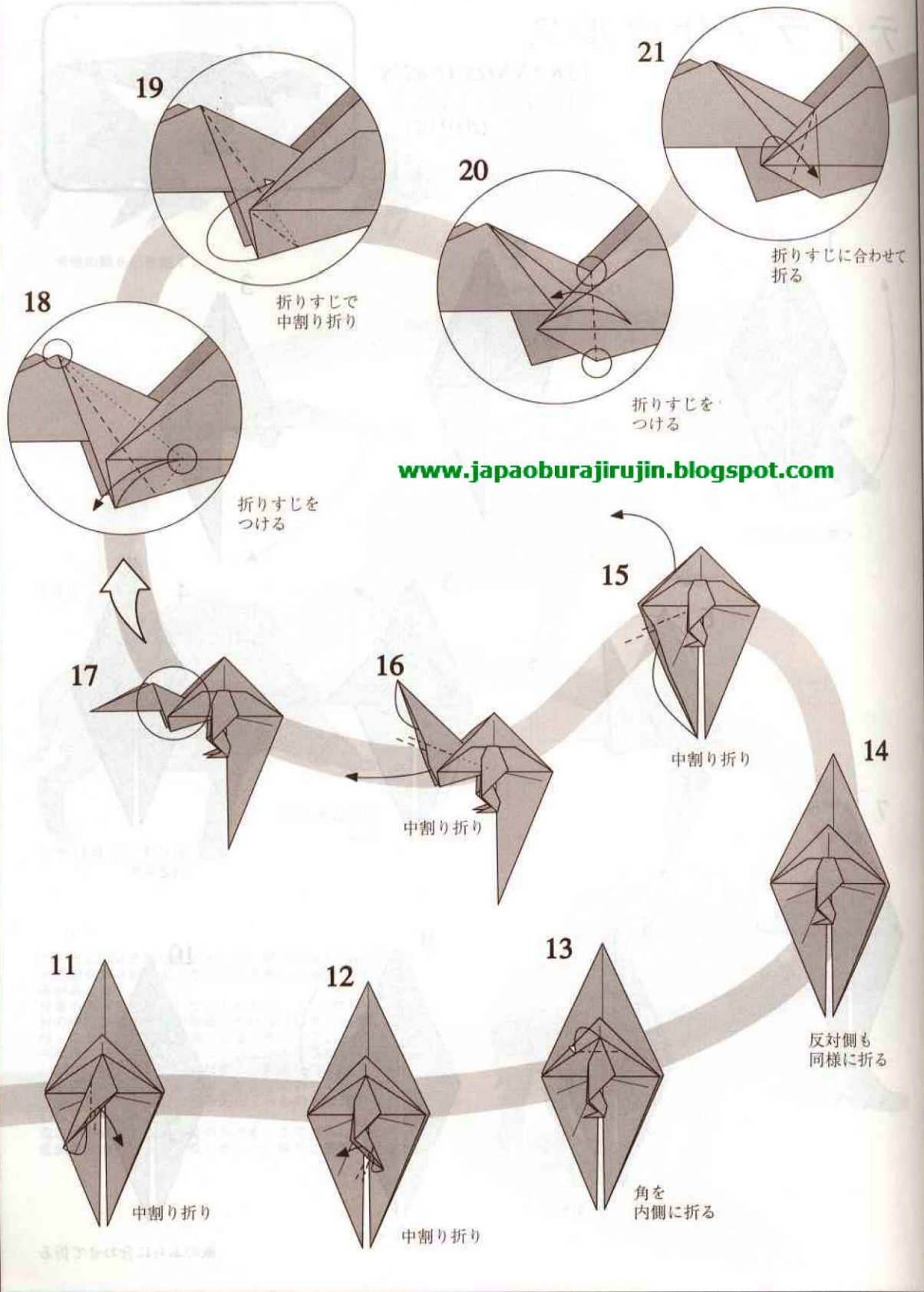



22

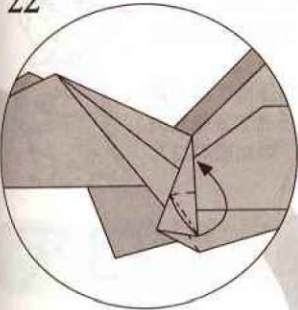

引き寄せるように折る

23

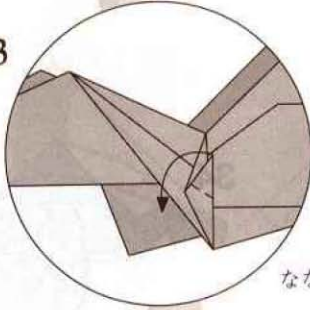

ななめに折る

24

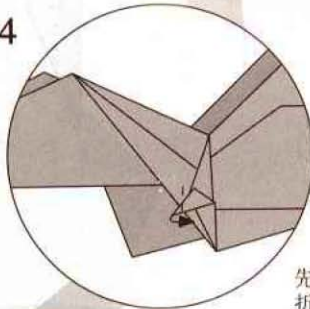

先端を折り返す

25

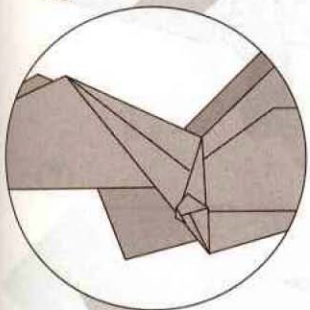

26



反対側も同様に折る

30



このように折る

29

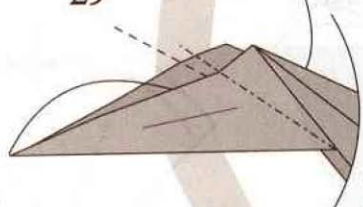

つけたしを角に合わせるように中割り折り(次図参照)

28

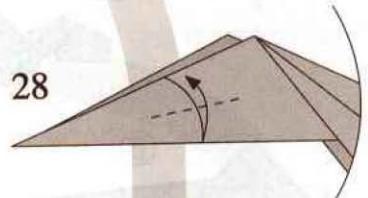

紙のふちを合わせてしるしをつける

27

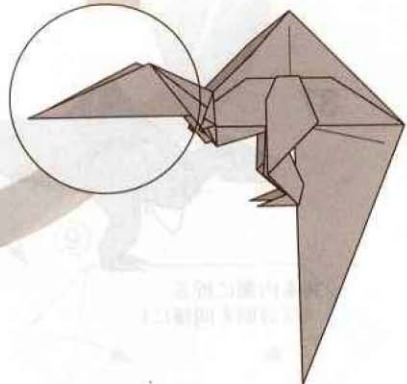

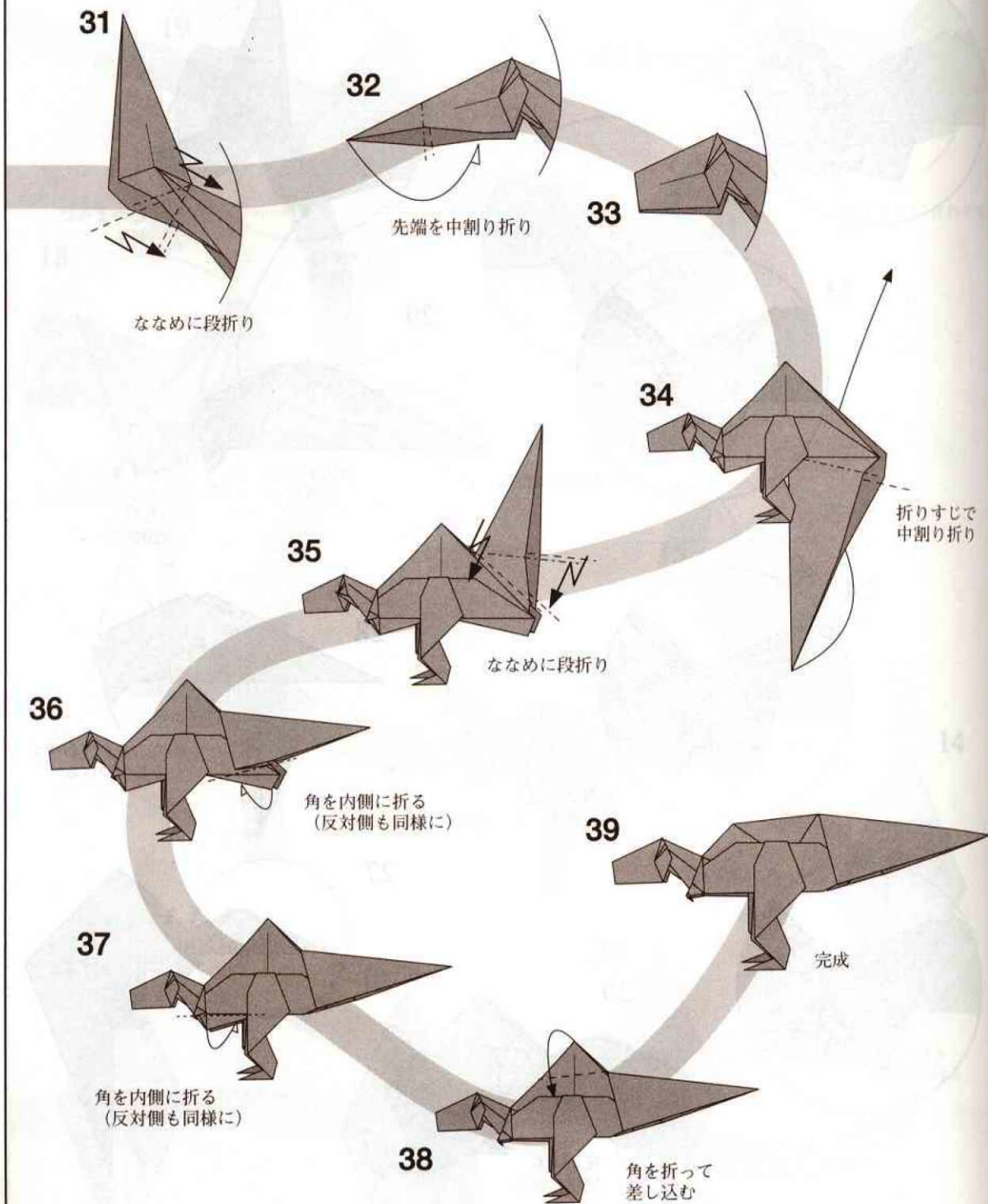



昨年、発表したセイスモサウルスの基本型のバランスを変えてアロサウルスを作ってみました。

福井県で化石が見つかり、日本で初めて復元された肉食恐竜である「フクイラプトル」もこのアロサウルスに体型は似ていたと考えられています。

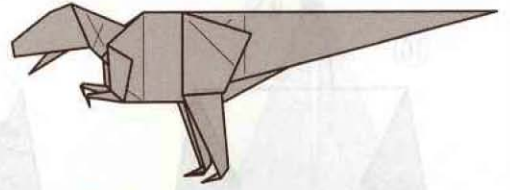

高井 弘明 May 18 2003

# アロサウルス Allosaurus

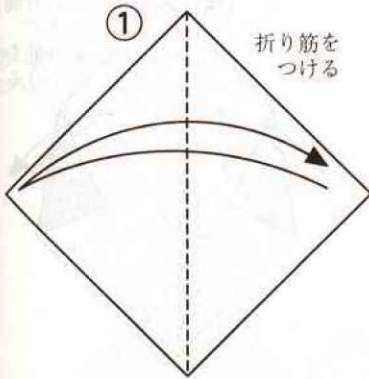

① 折り筋をつける

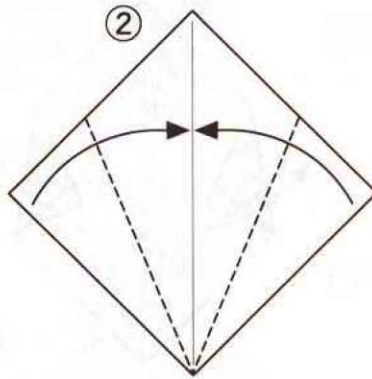

②

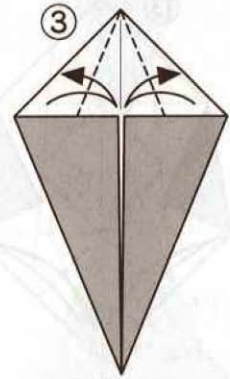

折り筋をつける

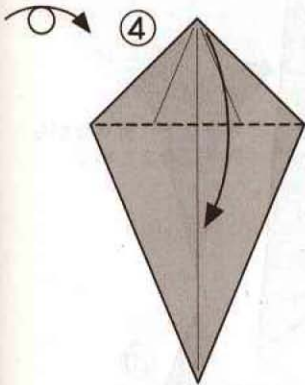

④ カドのところから折る

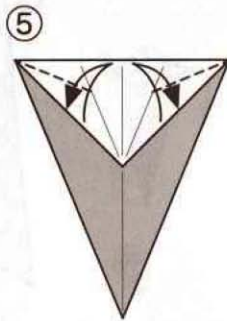

⑤ 折り筋をつける

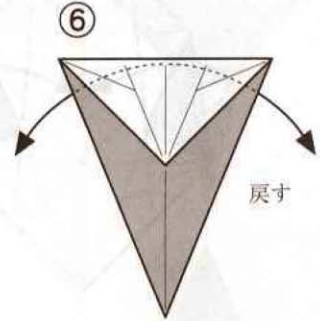

⑥ 戻す

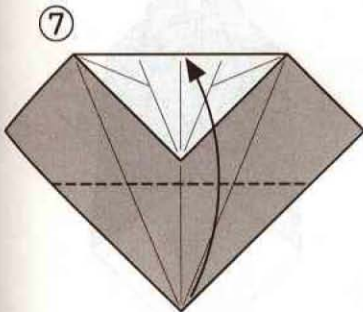

⑦ カドをふちに合わせるように折る

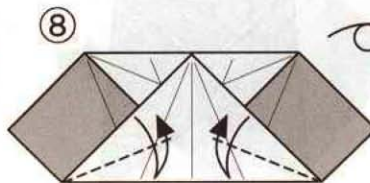

⑧ 折り筋をつける

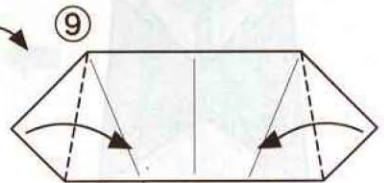

⑨ カドのところから折る

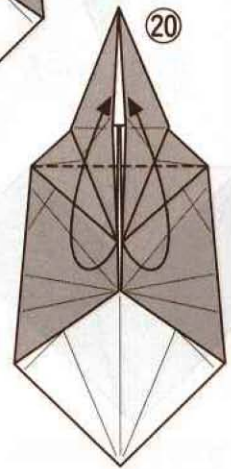
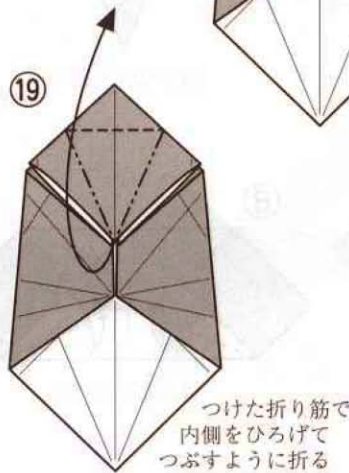
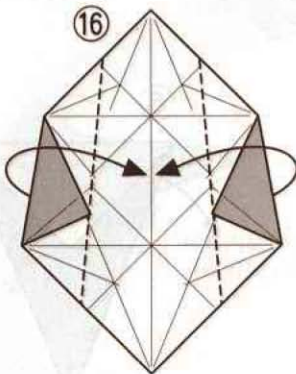
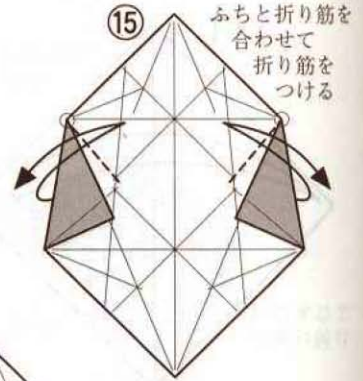
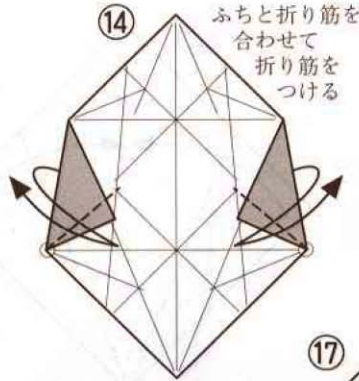
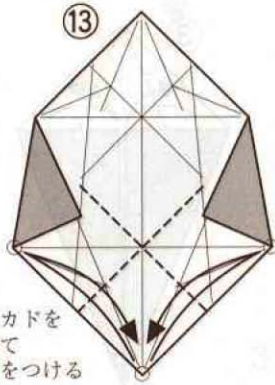
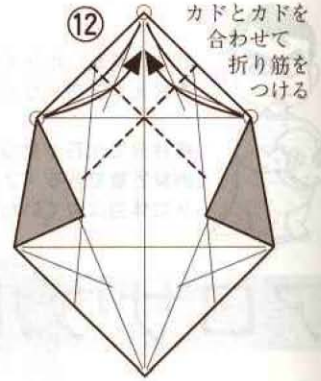
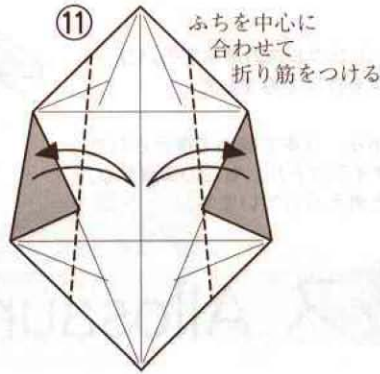
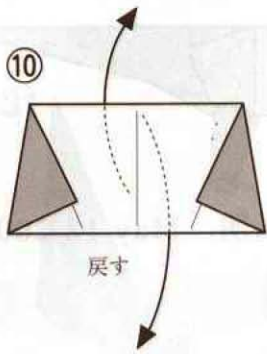

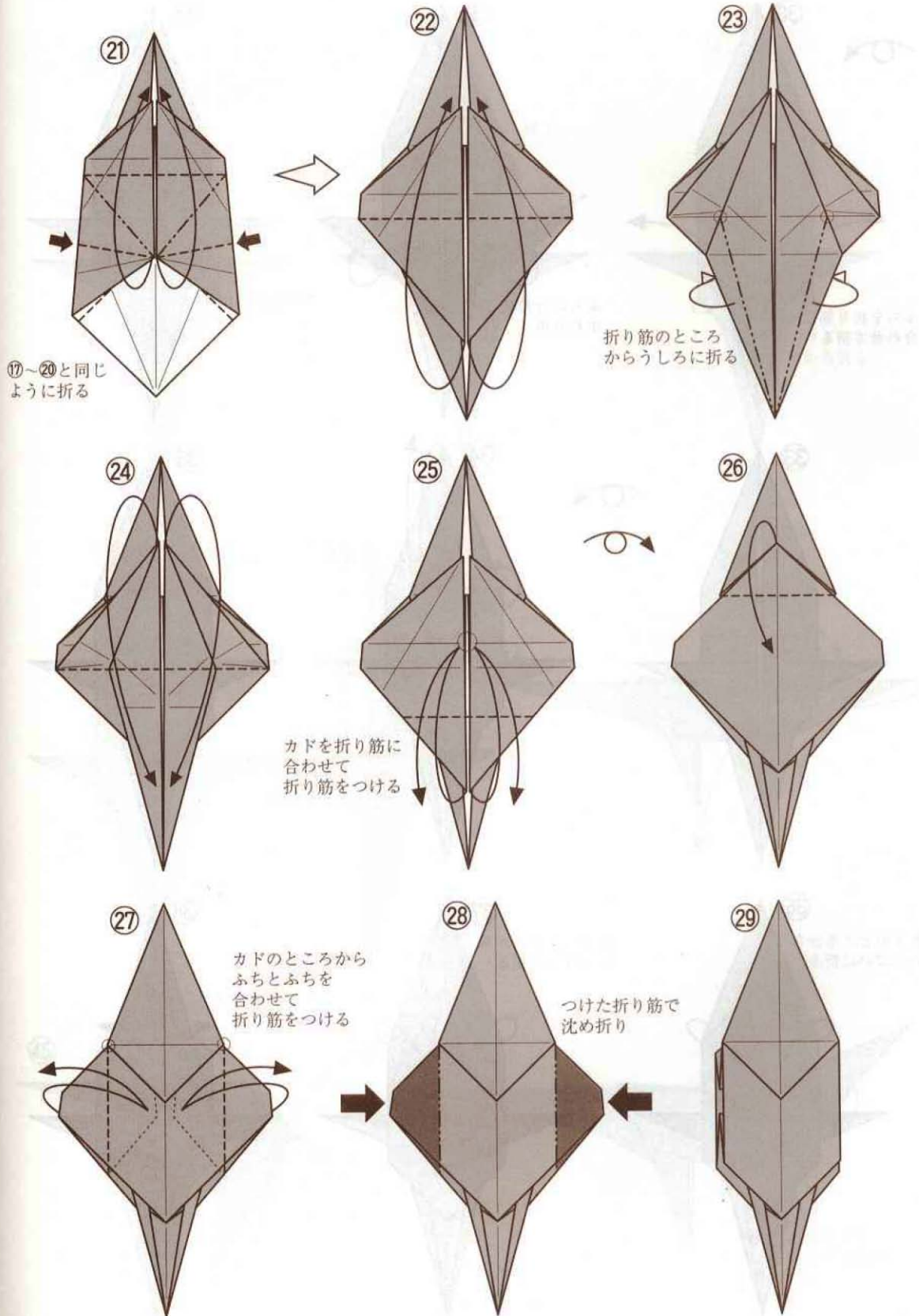

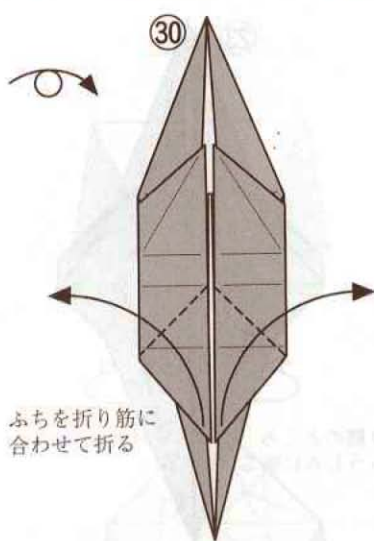

ふちを折り筋に合わせて折る

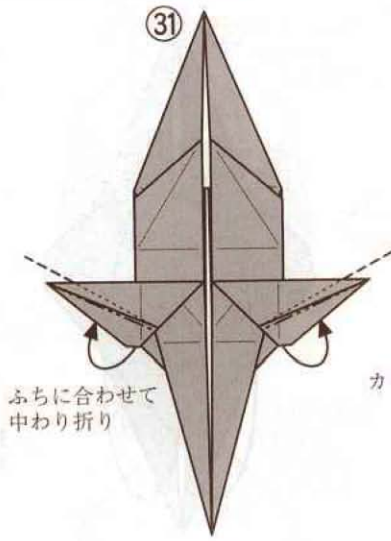

ふちにに合わせて  
中わり折り

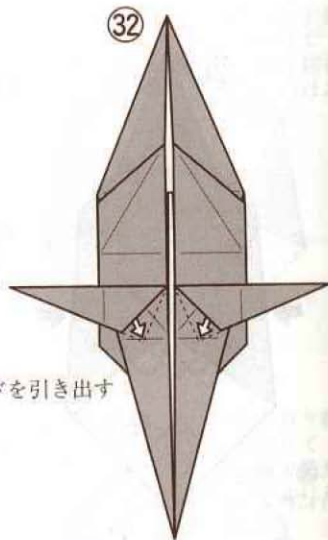

カドを引き出す

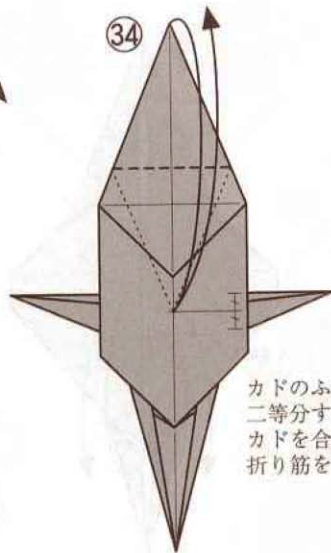
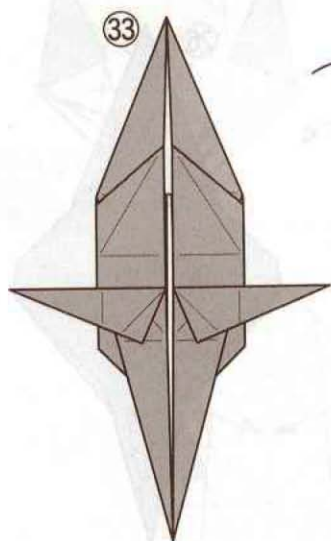

カドのふちを  
二等分するところに  
カドを合わせて  
折り筋をつける

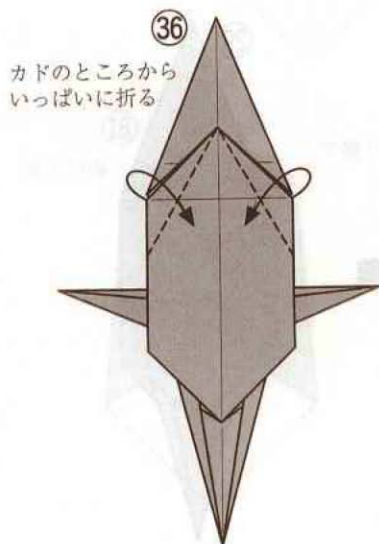
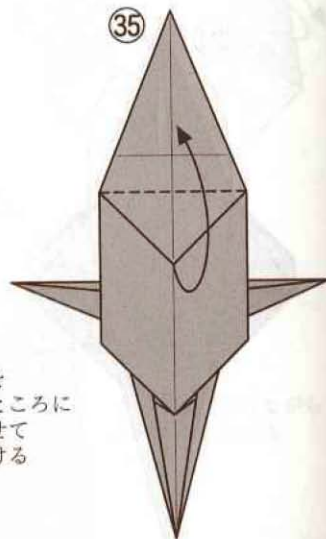

カドのところから  
いっぱい折る

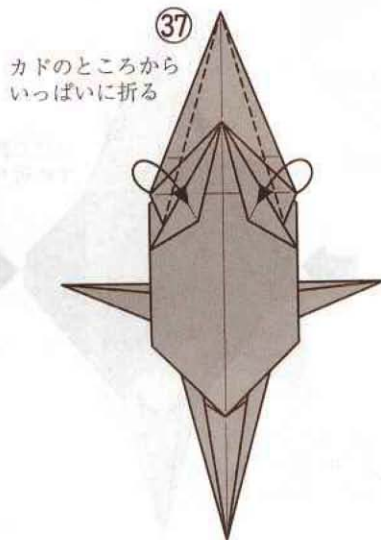

カドのところから  
いっぱい折る

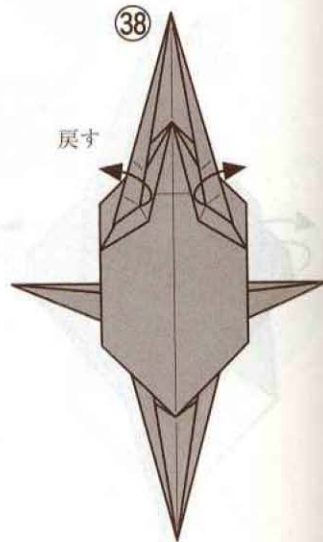

戻す

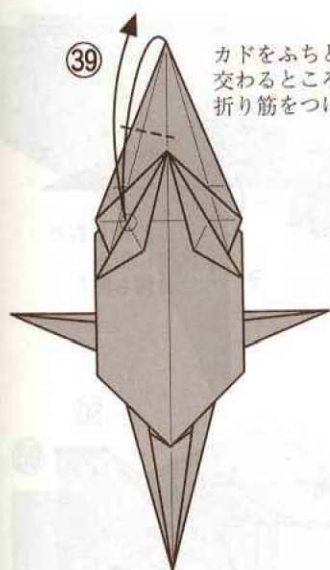

カドをふちと折り筋が  
交わるところで  
折り筋をつける

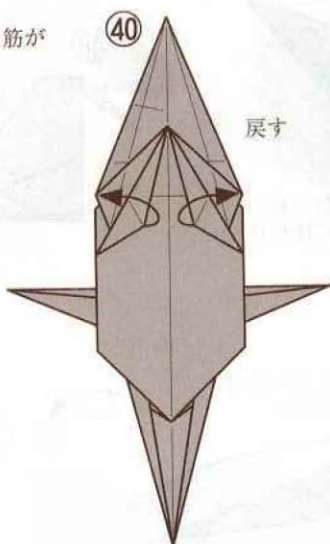

戻す

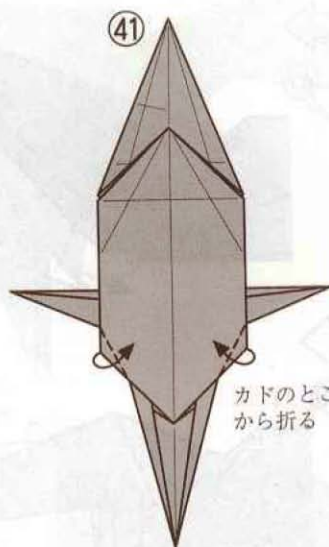

カドのところ  
から折る

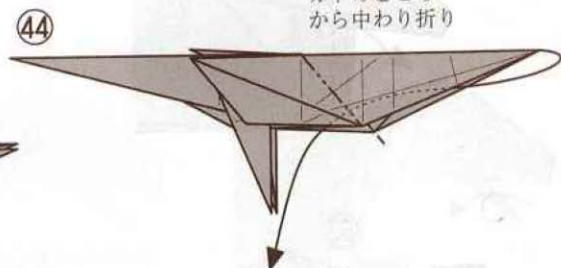
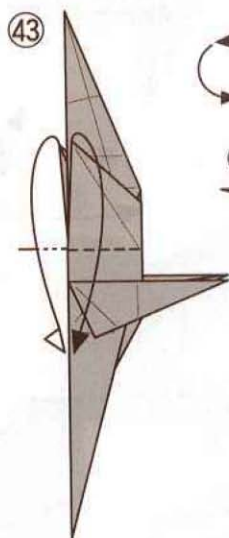
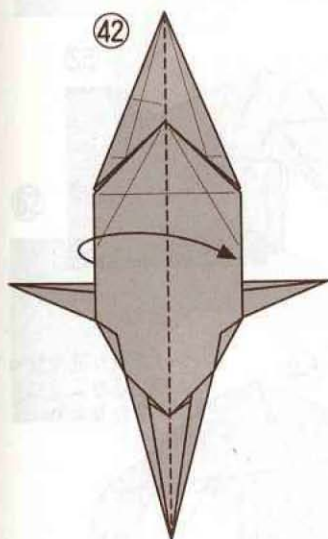

カドのところ  
から中わり折り

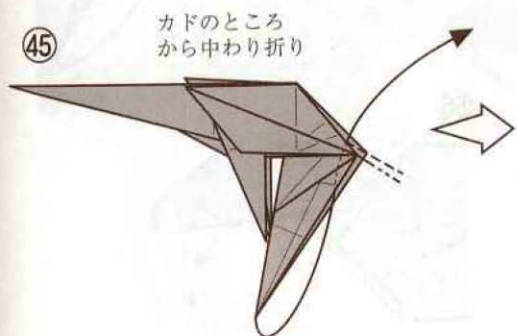

カドのところ  
から中わり折り

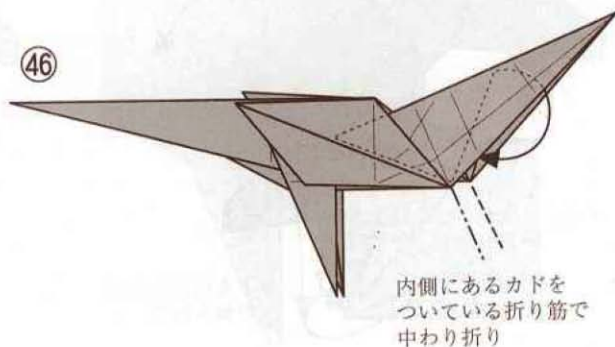

内側にあるカドを  
ついている折り筋で  
中わり折り

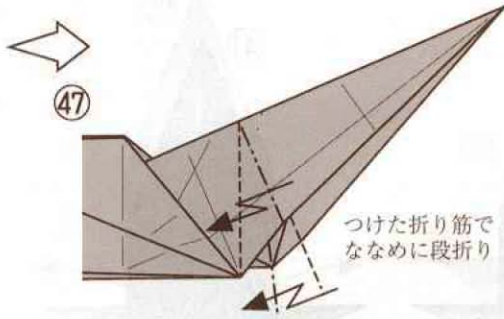

つけた折り筋で  
ななめに段折り

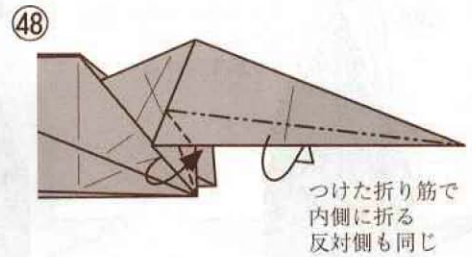

つけた折り筋で  
内側に折る  
反対側も同じ

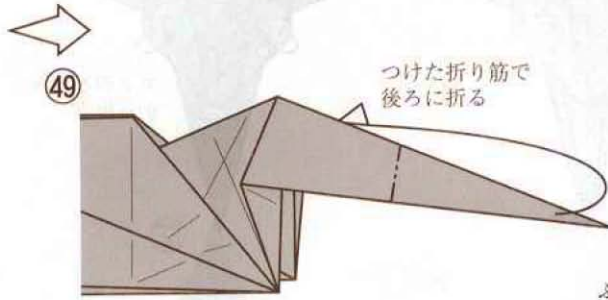

つけた折り筋で  
後ろに折る

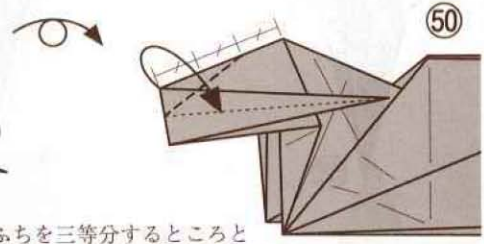

ふちを三等分するところと  
内側で紙が厚くなっているところ  
を結ぶ線で折る

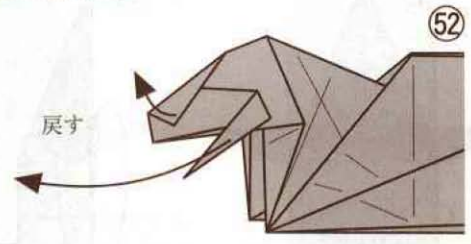
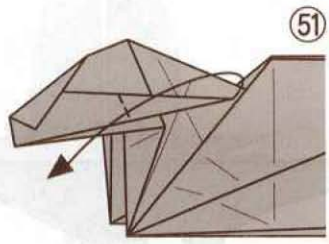

戻す

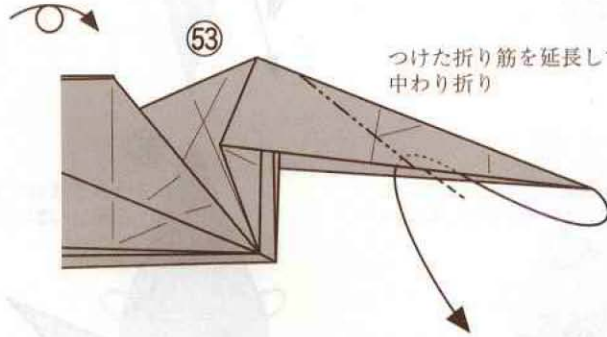

つけた折り筋を延長して  
中わり折り

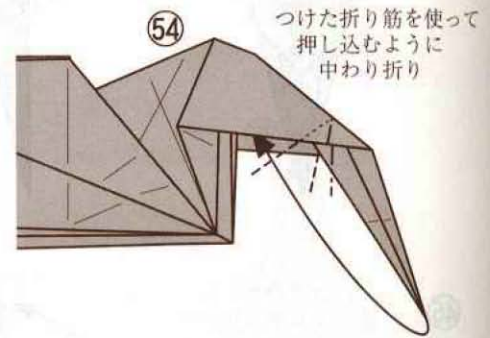

つけた折り筋を使って  
押し込むように  
中わり折り



カドを内側に折る  
反対側も同じ

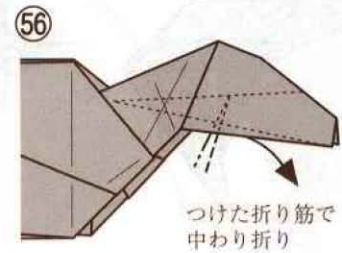

つけた折り筋で  
中わり折り



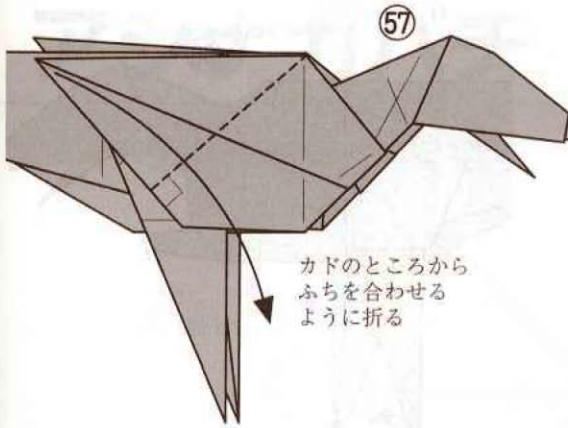

57

カドのところから  
ふちを合わせる  
ように折る

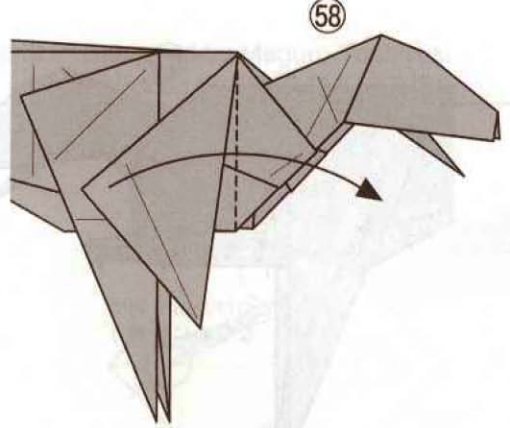

58



59

カドを三等分する  
角度で折る

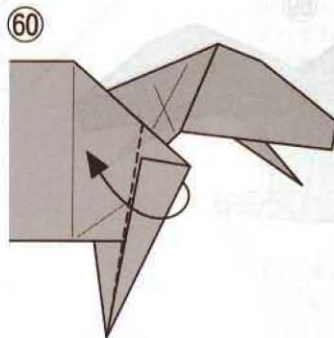

60

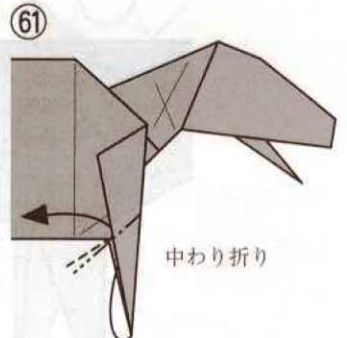

61

中わり折り

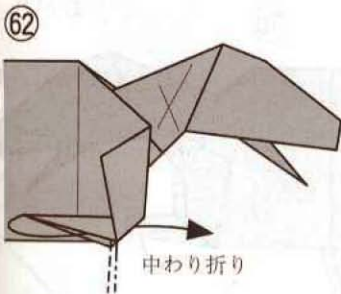

62

中わり折り

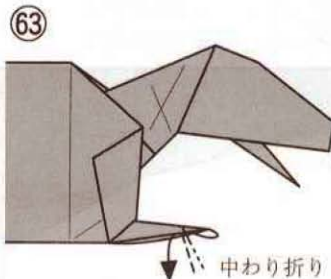

63

中わり折り

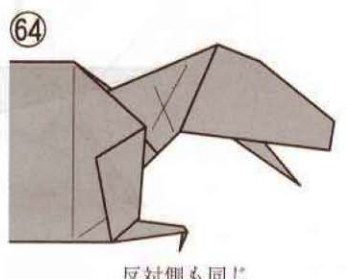

64

反対側も同じ  
ように折る

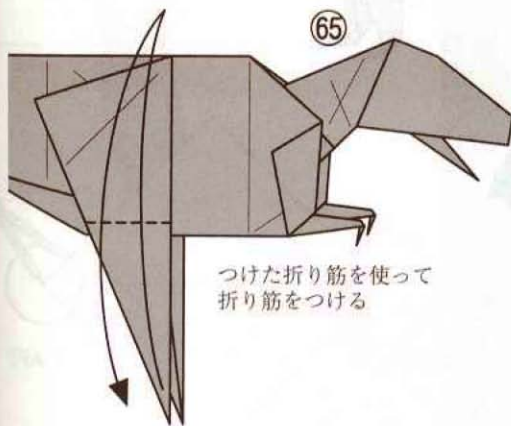

65

つけた折り筋を使って  
折り筋をつける

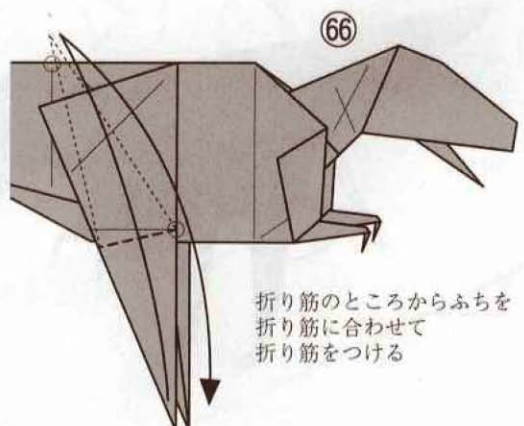

66

折り筋のところから  
ふちを  
折り筋に合わせて  
折り筋をつける

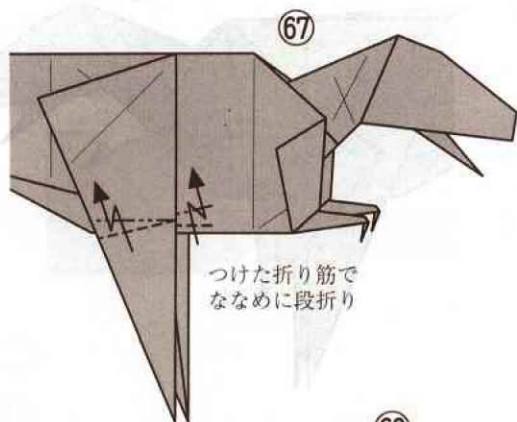

つけた折り筋で  
ななめに段折り

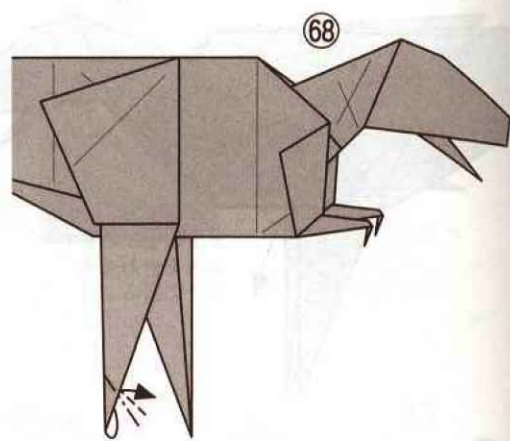

中わり折り

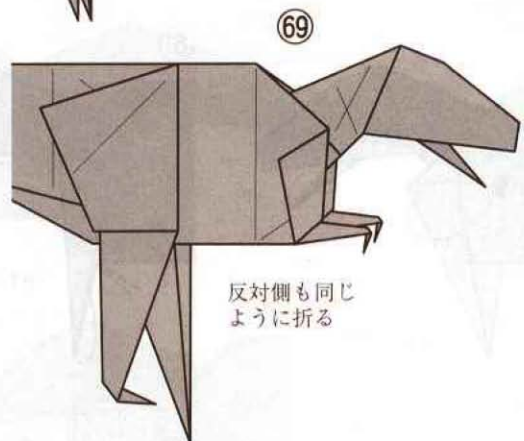

反対側も同じ  
ように折る

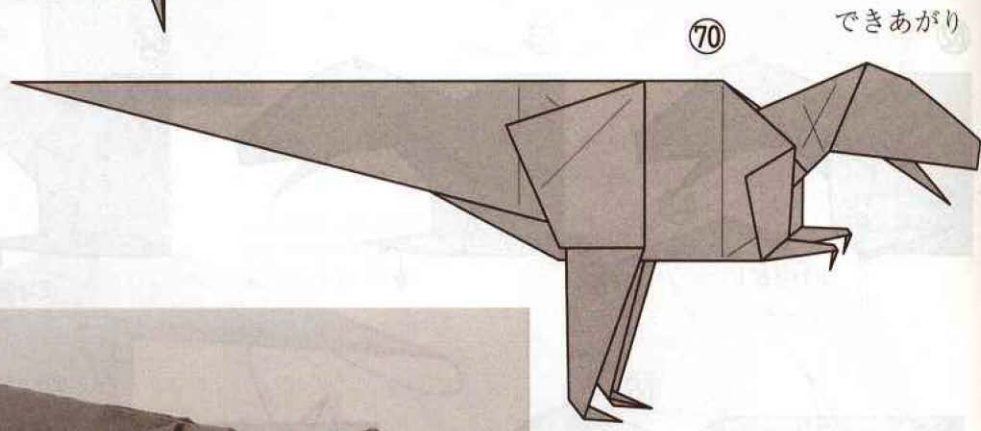

できあがり

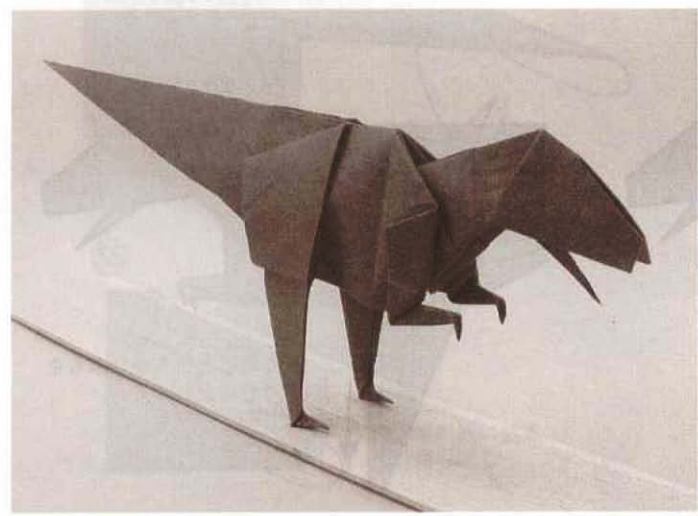

# アシナガバチ

目黒俊幸 / Designed by Meguro Toshiyuki  
Diagrams and Edited by ORIGAMI HOUSE

## Long-legged wasp

三角に  
折り筋をつける

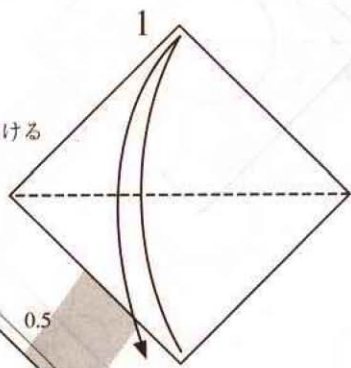

2

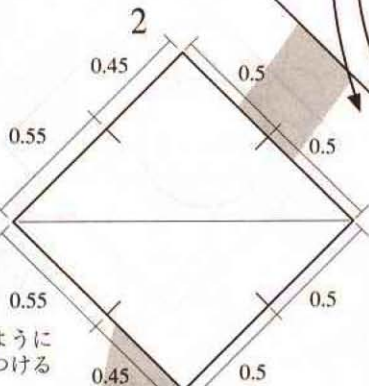

図のように  
印をつける

3

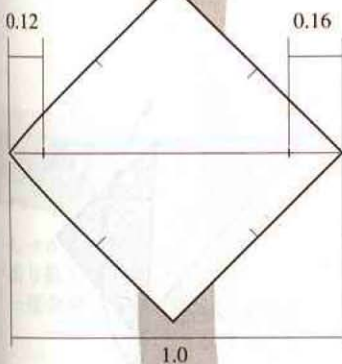

図のように  
印をつける

4

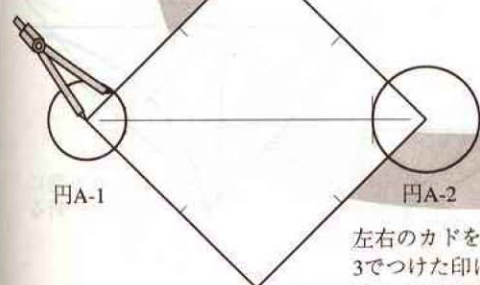

円A-1

円A-2

左右のカドを中心にして  
3でつけた印に触れるように  
コンパスで円を描き込む

7

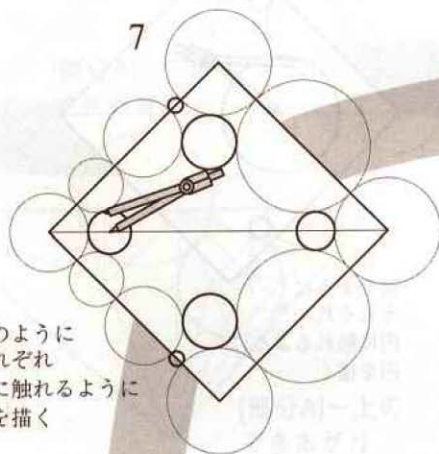

図のように  
それぞれ  
円に触れるように  
円を描く

6

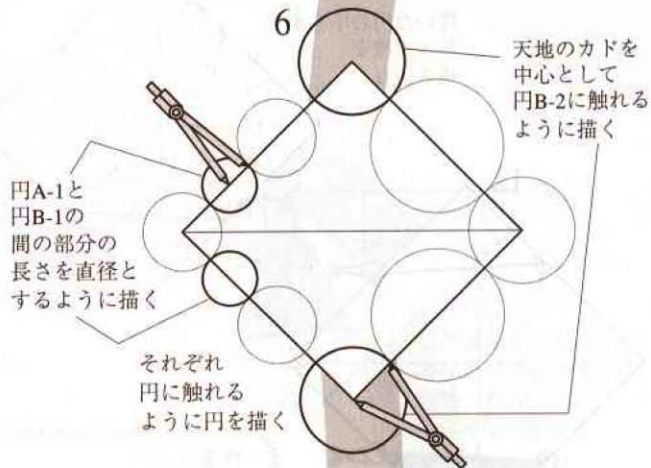

天地のカドを  
中心として  
円B-2に触れる  
ように描く

円A-1と  
円B-1の  
間の部分の  
長さを直径と  
するように描く

それぞれ  
円に触れる  
ように円を描く

5

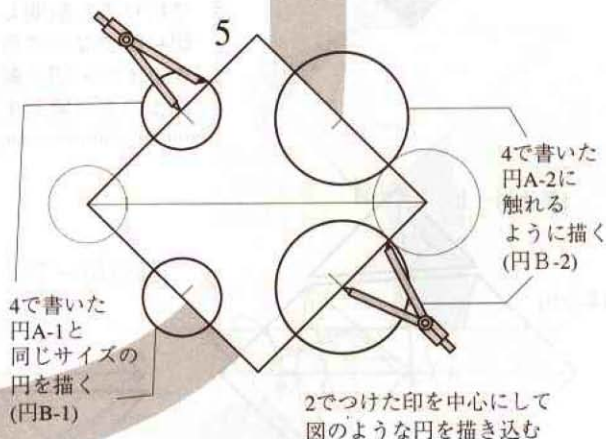

4で書いた  
円A-2に  
触れる  
ように描く  
(円B-2)

4で書いた  
円A-1と  
同じサイズの  
円を描く  
(円B-1)

2でつけた印を中心にして  
図のような円を描き込む

8

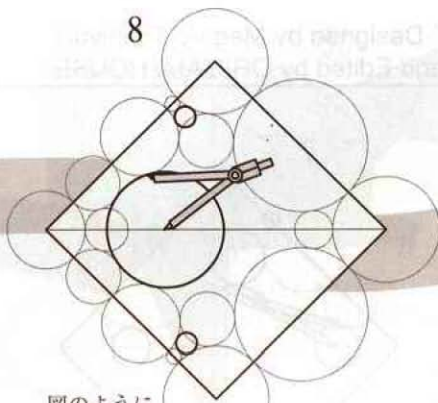

図のように  
それぞれ  
円に触れるように  
円を描く

9

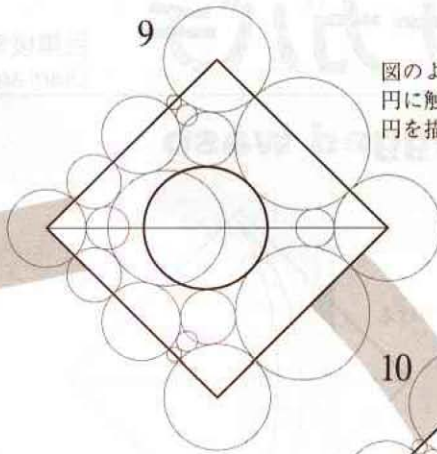

図のように  
円に触れるように  
円を描く

10

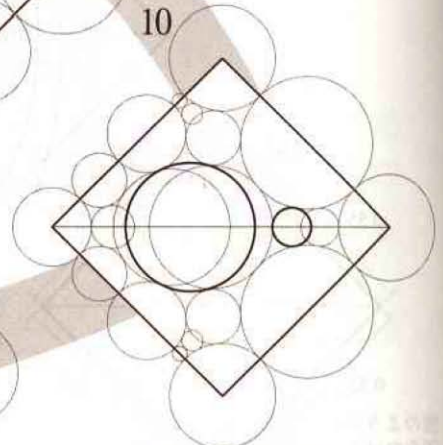

図のようにそれぞれ  
円に触れるように  
円を描く

11

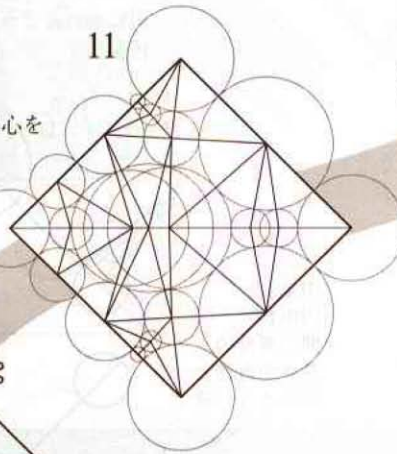

描いた円の中心を  
結んで線を  
描き込む

12

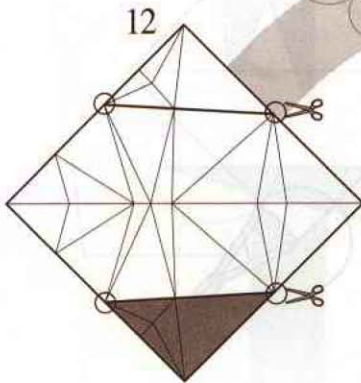

-作者より-  
アミの部分切り離した状態  
で折り方を説明します。  
切り離さないで折ることが  
できますが、切り離して折っ  
てみるのも一興です。

4

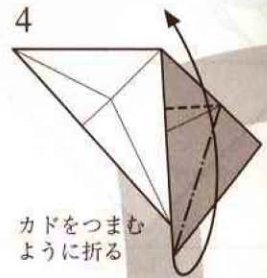

カドをつまむ  
ように折る

[部分A]-上

1

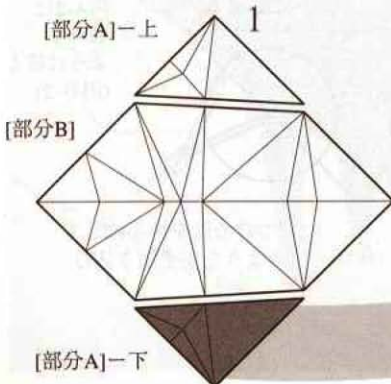

[部分B]

[部分A]-下

[部分A]-下

2

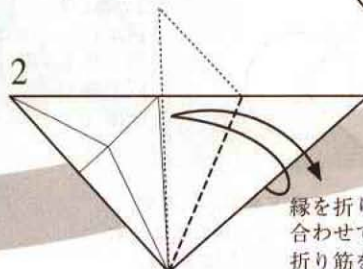

縁を折り筋に  
合わせて  
折り筋をつける

3

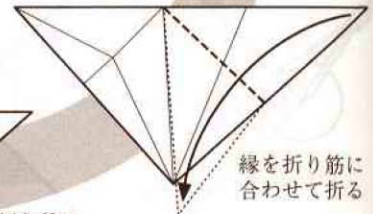

縁を折り筋に  
合わせて折る

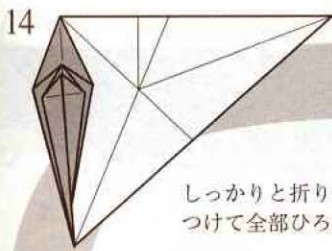

しっかりと折り筋をつけて全部ひろげる

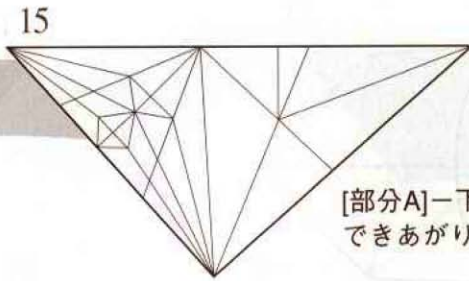

[部分A]一下の  
できあがり

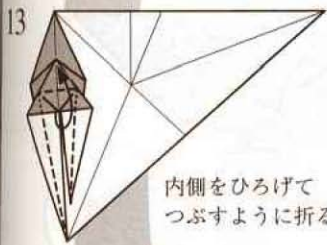

内側をひろげて  
つぶすように折る

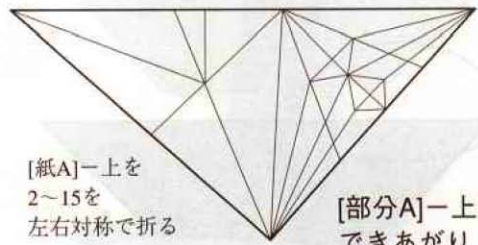

[紙A]一上を  
2~15を  
左右対称で折る

[部分A]一上の  
できあがり

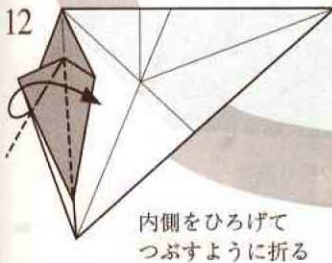

内側をひろげて  
つぶすように折る

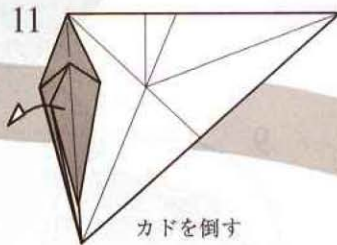

カドを倒す

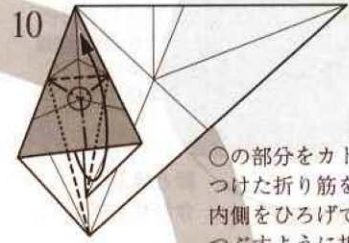

○の部分のカドにして  
つけた折り筋を使って  
内側をひろげて  
つぶすように折る



しっかりと  
折り筋をつけて  
一度全部ひろげる

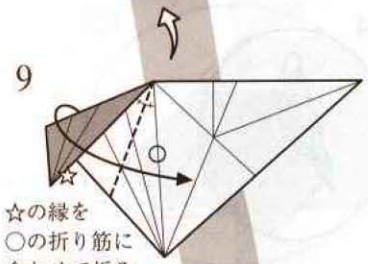

☆の線を  
○の折り筋に  
合わせて折る

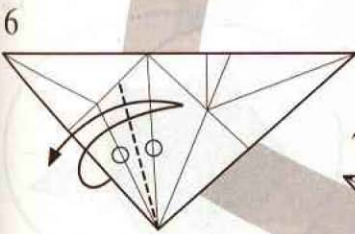

○の折り筋を  
合わせて  
折り筋をつける

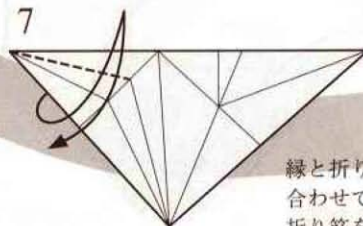

縁と折り筋を  
合わせて  
折り筋をつける

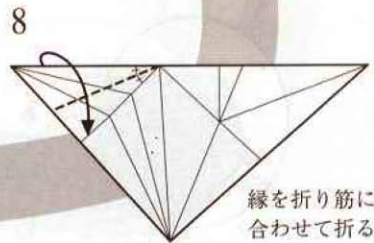

縁を折り筋に  
合わせて折る

[部分B]

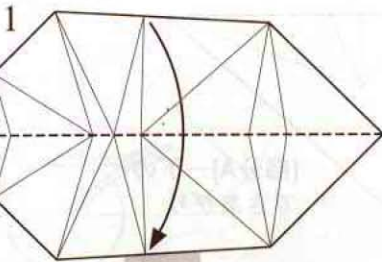

半分に折る

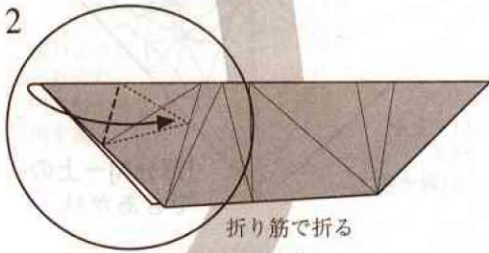

折り筋で折る

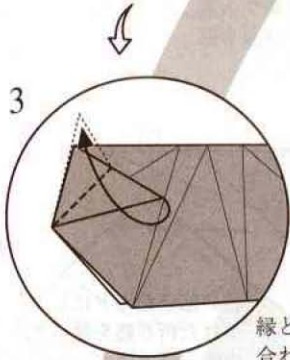

縁と縁を  
合わせて折る

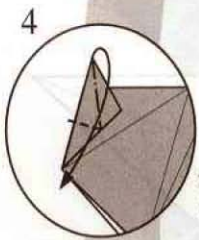

カドをつまむ  
ように折る

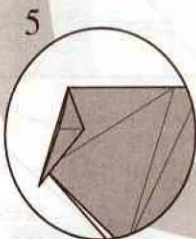

しっかりと折り筋を  
つけてから2の形に戻す

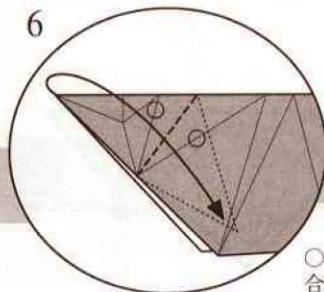

○と○の折り筋を  
合わせて折る

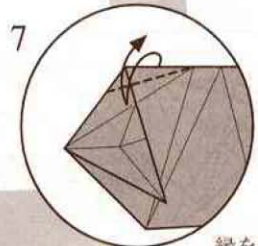

縁を折り筋に  
合わせて  
折り筋をつける

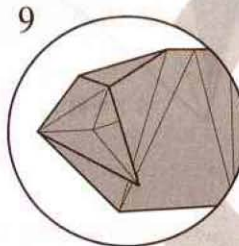

しっかりと折り筋を  
つけてから2の  
形に戻す



★の折り筋で  
折る

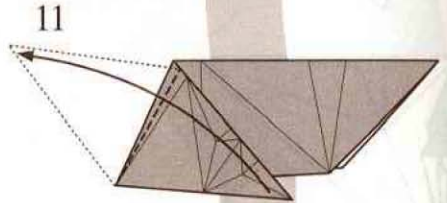

○の折り筋と縁を  
合わせて折る

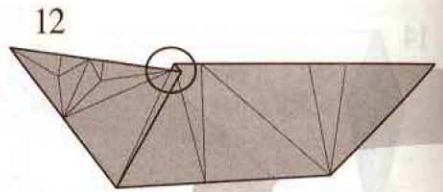

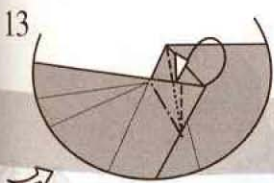

13  
カドを内側に折る

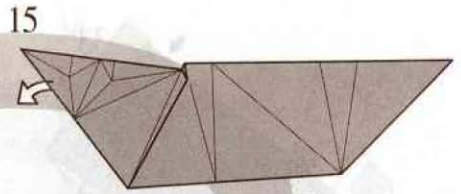
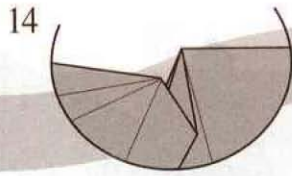

15  
しっかりと折り筋をつけてから10の形に戻す

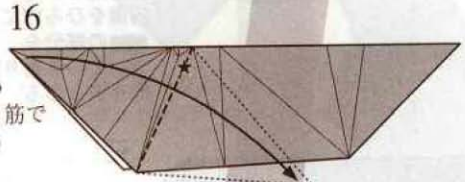

16  
★の折り筋で折る

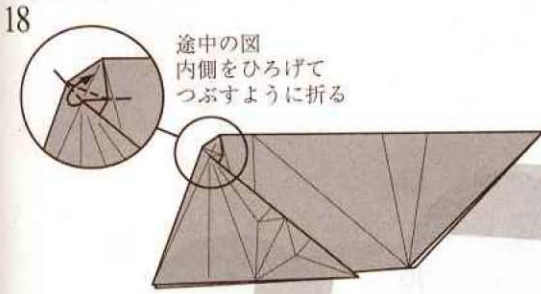

18  
途中の図内側をひろげてつぶすように折る

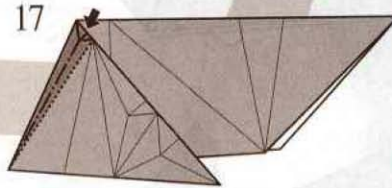

17  
黒矢印の部分を押し込むように内側をひろげて  
■の部分をついている折り筋で折りまとめる

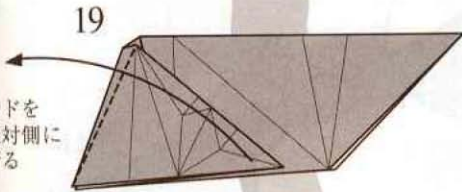

19  
カドを反対側に折る

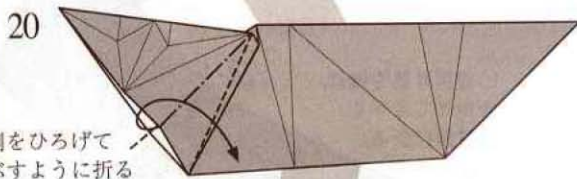

20  
内側をひろげてつぶすように折る

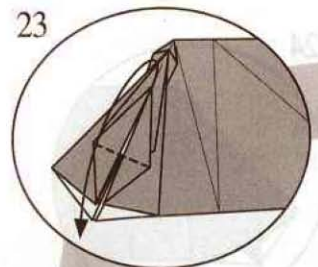

23  
カドを下に折る

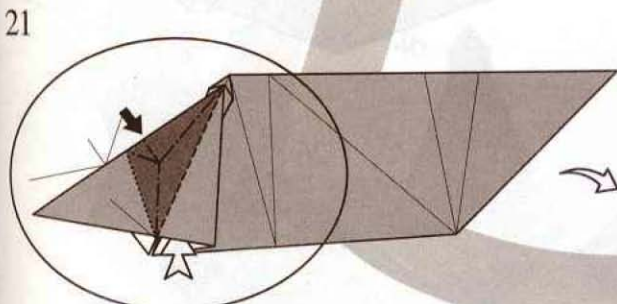

21  
黒矢印の部分を押し込むように内側をひろげて■の部分をついている折り筋で折りまとめる

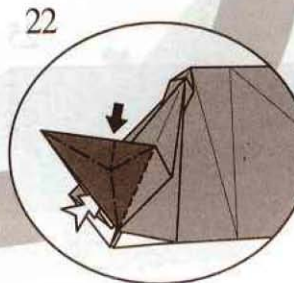

22  
黒矢印の部分を押し込むように内側をひろげて■の部分をついている折り筋で折りまとめる

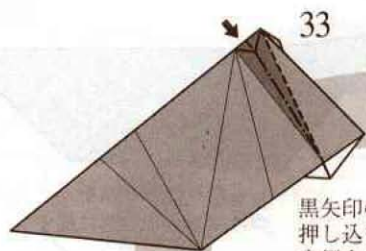

33

黒矢印の部分を押し込むように内側をひろげて  
■の部分をついている折り筋で折りまとめる

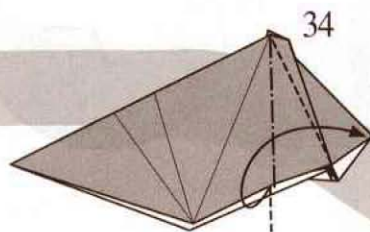

34

内側をひろげてつぶすように折る

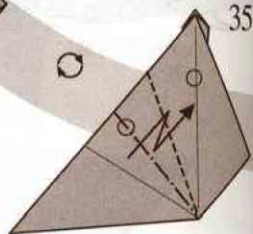

35

○と○の折り筋を合わせて斜めに段折り

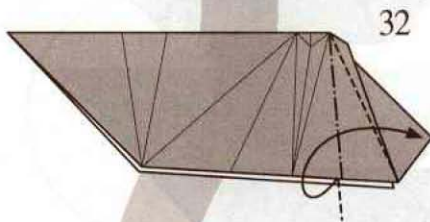

32

内側をひろげてつぶすように折る

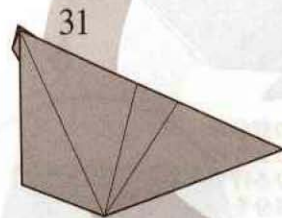

31

しっかりと折り筋をつけて25の形まで戻す

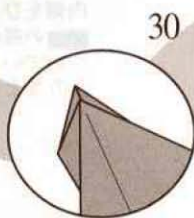

30

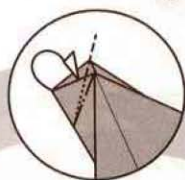

29

縁と縁を合わせてカドを内側に折る

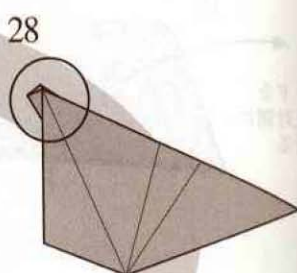

28

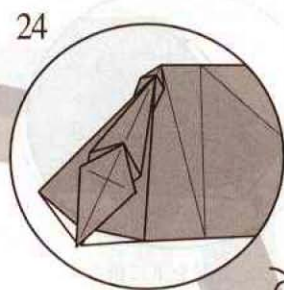

24

○の折り筋を縁に合わせてカドを反対側に折る

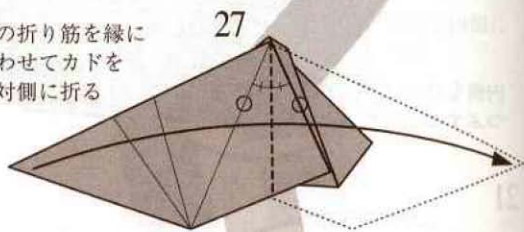

27

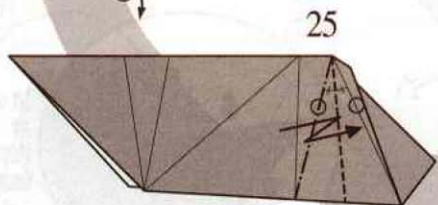

25

○と○の折り筋を合わせて斜めに段折り

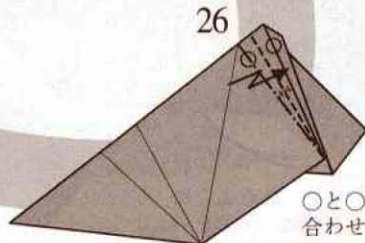

26

○と○の折り筋を合わせて斜めに段折り



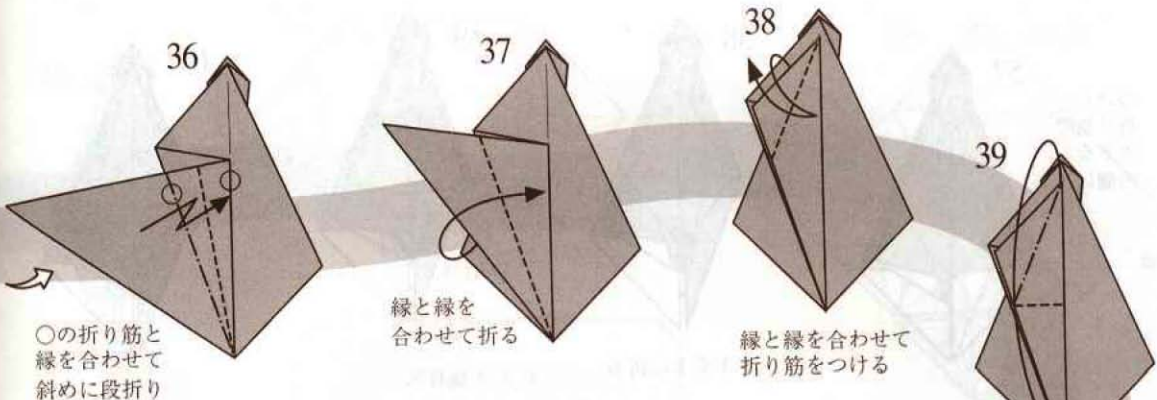

○の折り筋と  
縁を合わせて  
斜めに段折り

縁と縁を  
合わせて折る

縁と縁を合わせて  
折り筋をつける

カドをつまむ  
ように折る

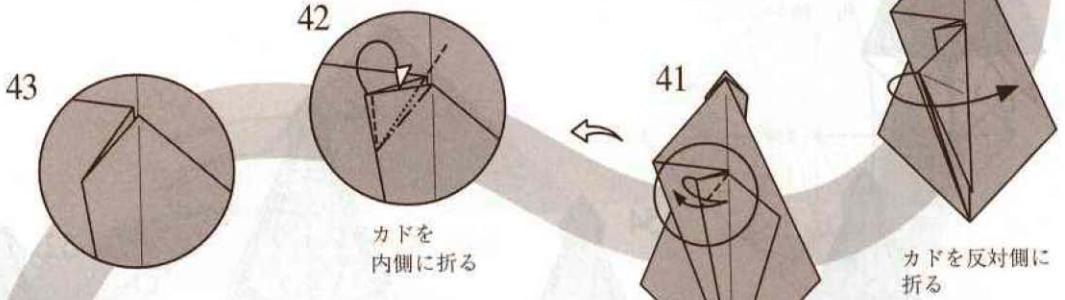

カドを反対側に  
折る

カドを  
内側に折る

縁を折り筋に  
合わせて  
折り筋をつける

縁を折り筋に  
合わせて  
折り筋をつける

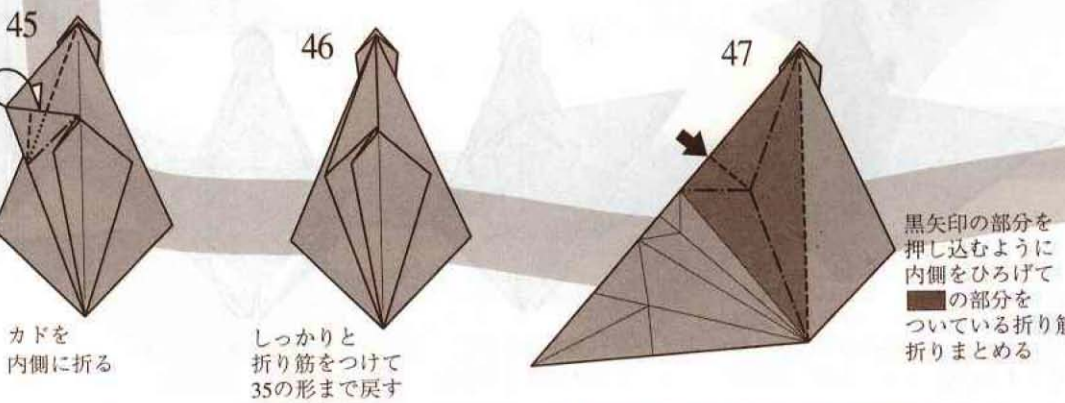
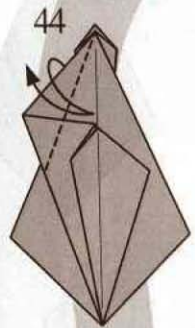

カドを  
内側に折る

しっかりと  
折り筋をつけて  
35の形まで戻す

黒矢印の部分  
押し込むように  
内側をひろげて  
■の部分  
ついている折り筋で  
折りまとめる

57

つけた  
折り筋で  
カドを  
内側に折る

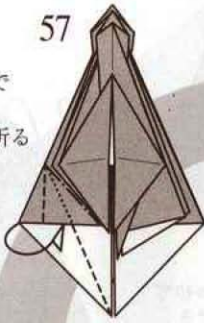

58

カドを下に折る

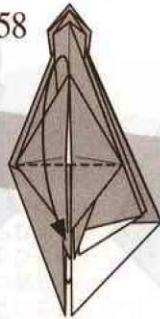

59

カドを  
反対側に折る

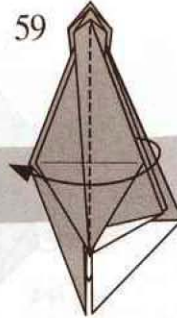

60

反対側も  
53~59と同じ

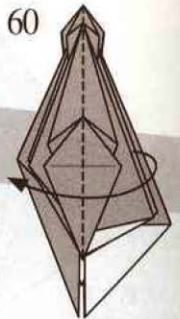

56

縁と縁を合わせて  
折り筋をつける

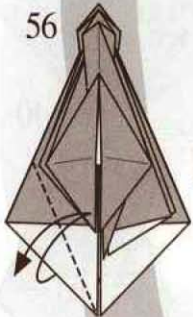

55

内側をひろげて  
つぶすように折る

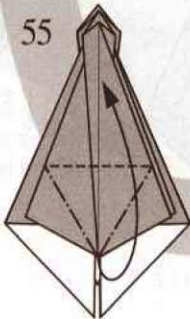

54

縁を折り筋に  
合わせて  
折り筋をつける

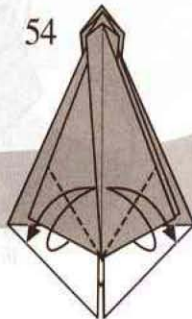

53

カドを3枚重ねて  
反対側に折る

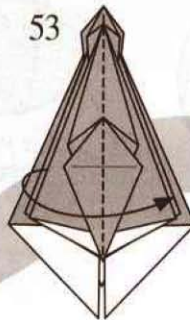

52

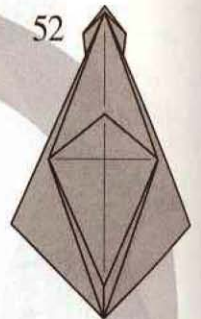

48

黒矢印の部分を  
押し込むように  
内側をひろげて  
■の部分  
についている折り筋で  
折りまとめる

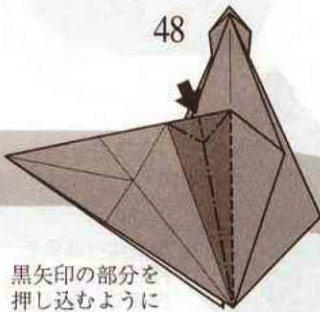

49

内側をひろげて  
つぶすように折る

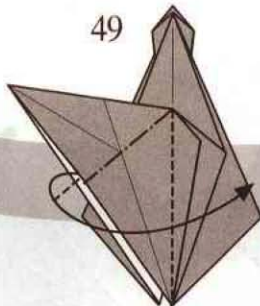

50

内側をひろげて  
つぶすように折る

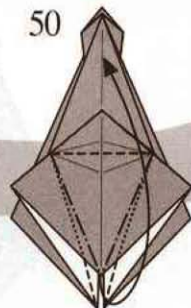

51

カドを下に折る

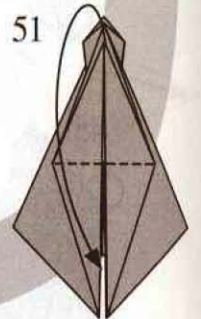

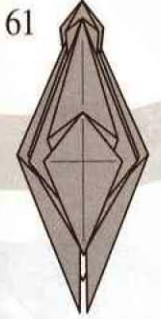

しっかりと  
折り筋をつけて  
全部ひろげる

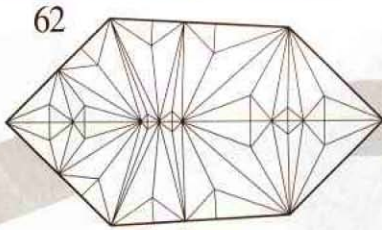

[部分B]の  
できあがり

-作者より-  
ここまで用紙を仮想的に分けて  
表示してきましたが、ここから  
はまた不切正方一枚として表示  
します。

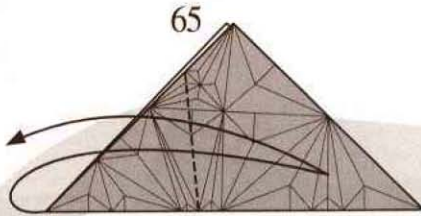
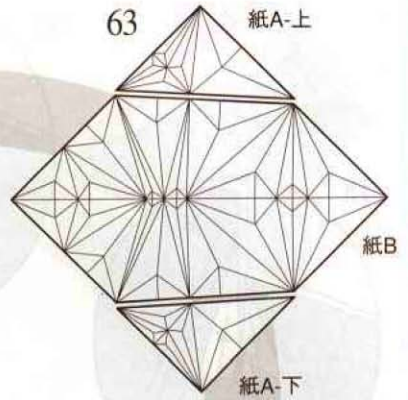

ついている折り筋を  
のばして折り筋を  
つける

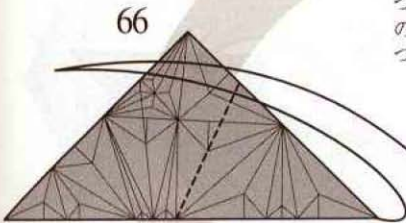

ついている折り筋を  
のばして折り筋を  
つける

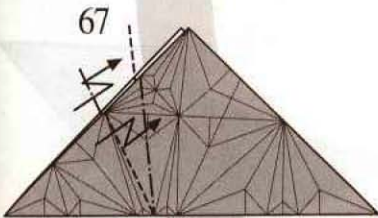

内側に段折り

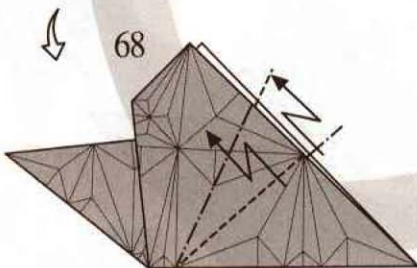

内側に段折り

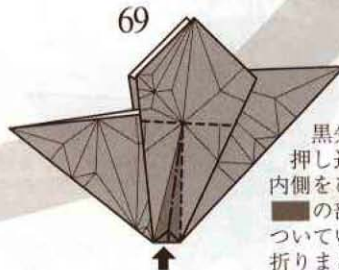

黒矢印の部分を  
押し込むように  
内側をひろげて  
■の部分をつ  
いている折り筋で  
折りまとめる

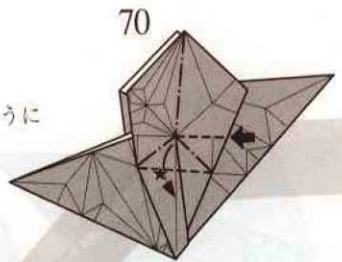

★のところを  
カドにするよう  
に  
ついている  
折り筋で  
折りまとめる

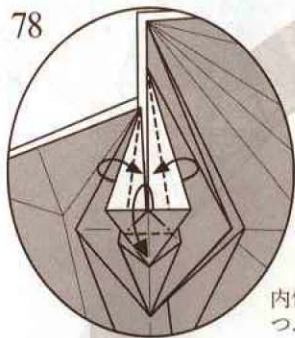

内側をひろげて  
つぶすように折る

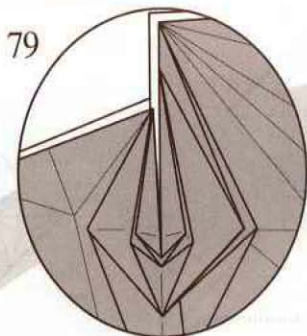

反対側も  
74~78と同じ  
ように折る

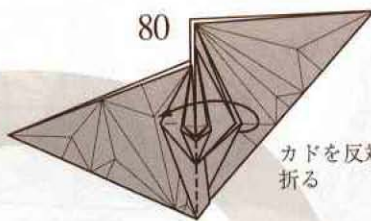

カドを反対側に  
折る

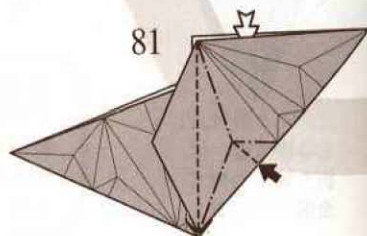

内側をひろげて  
黒矢印の部分  
押し込んで  
ついている折り筋で  
折りまとめる

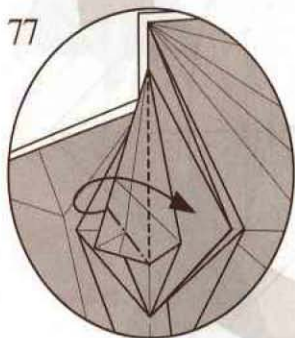

内側をひろげて  
つぶすように折る

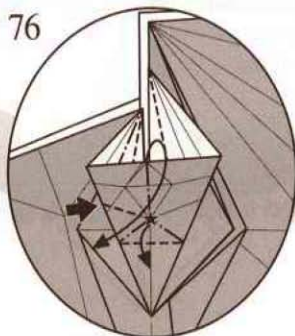

★のところが  
カドになるように  
ついている  
折り筋で  
折りまとめる

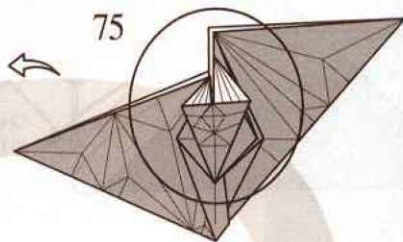

75

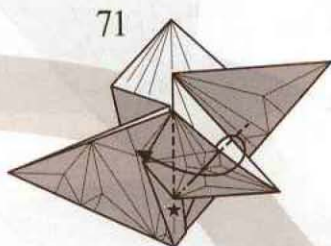

内側をひろげて  
つぶすように折る

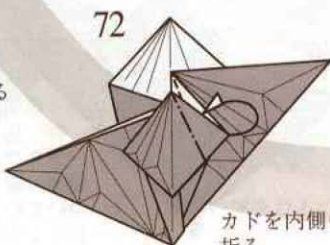

カドを内側に  
折る

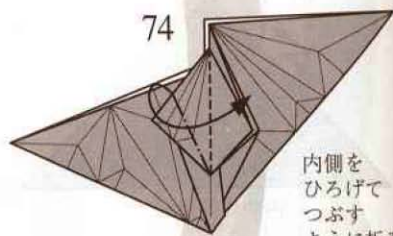

74

内側を  
ひろげて  
つぶす  
ように折る

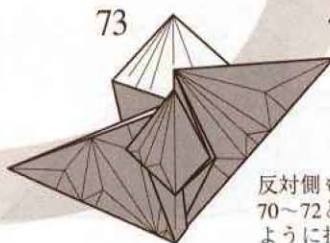

73

反対側も  
70~72と同じ  
ように折る

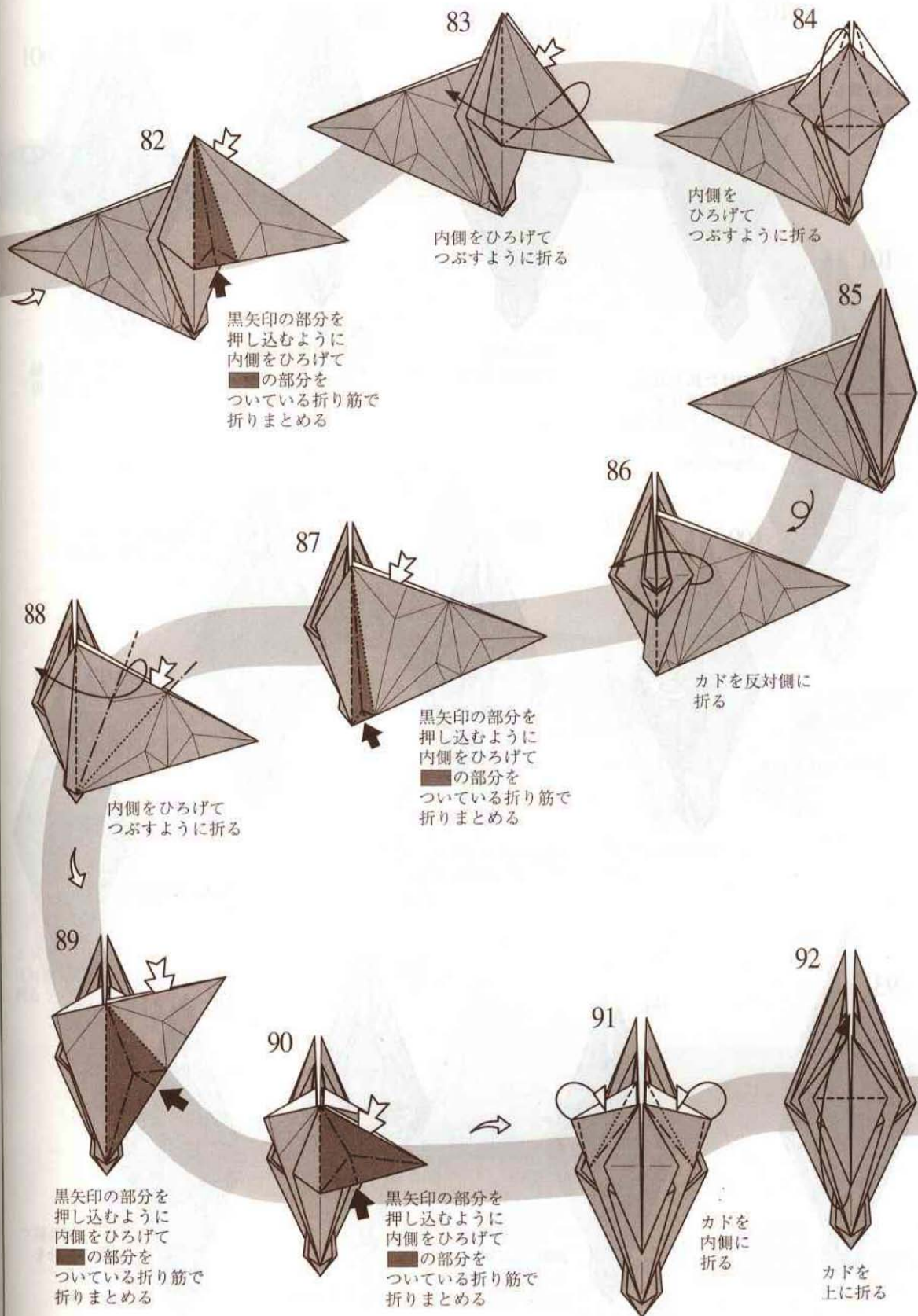

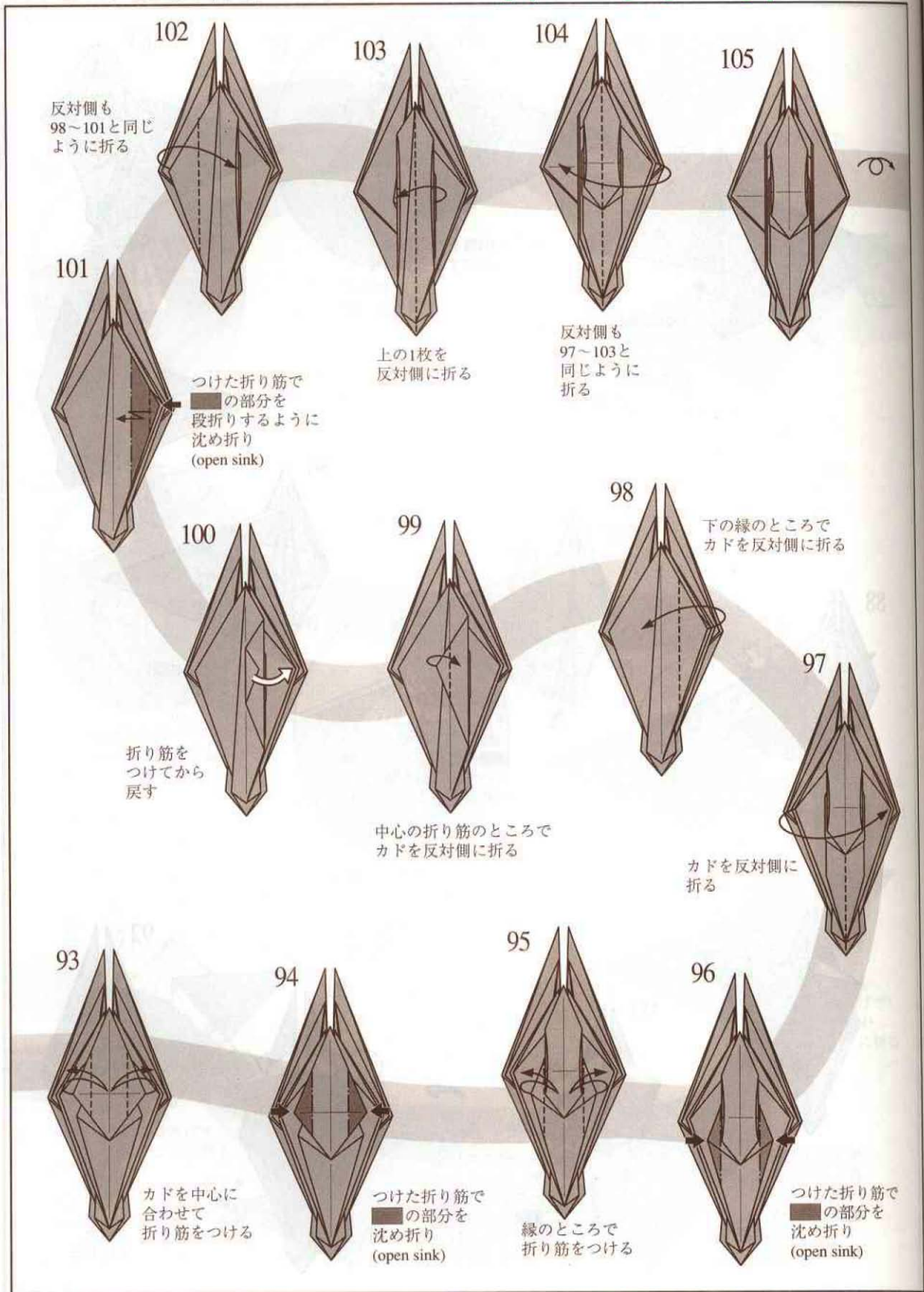

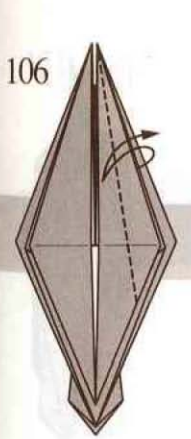

106  
縁と縁を合わせて  
折り筋をつける

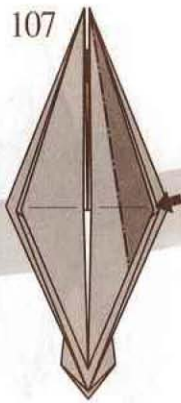

107  
つけた折り筋で  
■の部分  
沈め折り  
(Closed sink)

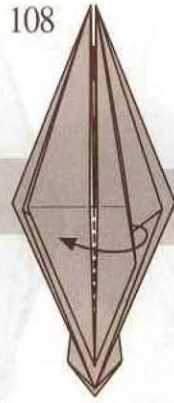

108  
カドを反対側に  
折る

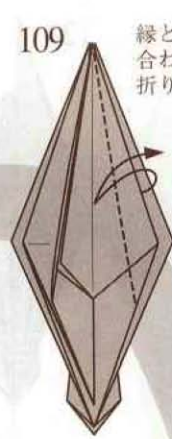

109  
縁と折り筋を  
合わせて  
折り筋をつける

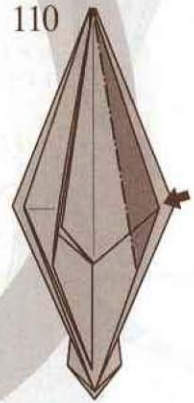

110

つけた折り筋で  
■の部分  
沈め折り  
(Closed sink)

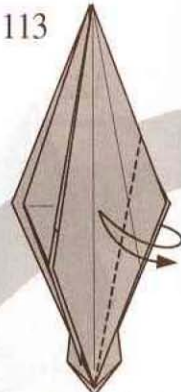

113

縁と折り筋を  
合わせて  
折り筋をつける

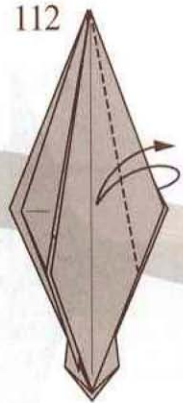

112

縁と折り筋を  
合わせて  
折り筋をつける

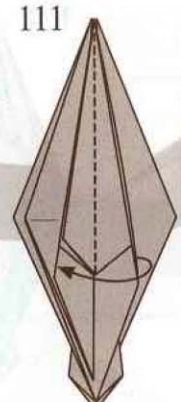

111

カドを反対側に  
折る

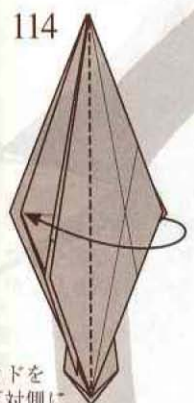

114

カドを  
反対側に  
折る

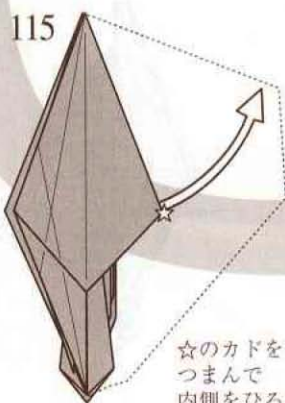

115

☆のカドを  
つまんで  
内側をひろげる

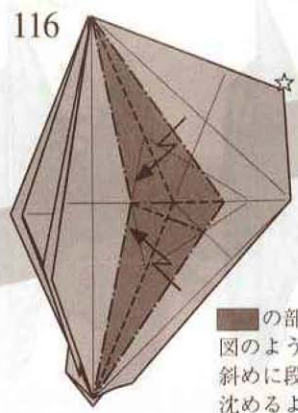

116

■の部分  
を  
図のような折り筋で  
斜めに段折りしながら  
沈めるように  
折りまとめる

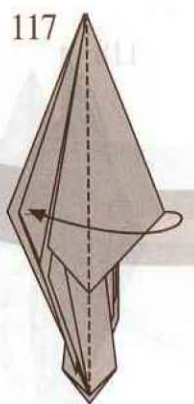

117

カドを2枚重ねて  
反対側に折る

126



開くところで  
カドを  
下に折る

127



カドを  
反対側に  
折る

128



縁を折り筋に  
合わせて折る

129



カドを縁に  
沿って折る

130

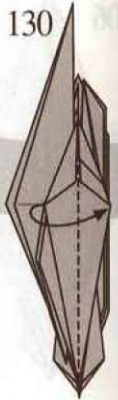

カドを3枚重ねて  
反対側に折る

125



開くところで  
カドを折り下げる

124



カドを  
反対側に折る

123



開くところで  
カドを折り上げる

122



の部分を  
図のような折り筋で  
斜めに段折りしながら

118

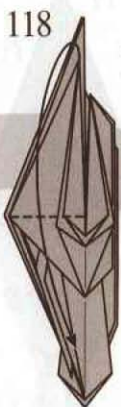

カドを折り下げる

119

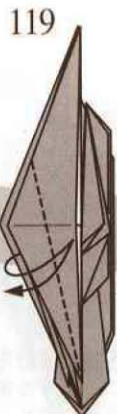

縁と縁を合わせて  
折り筋をつける

120



縁と縁を合わせて  
折り筋をつける

121

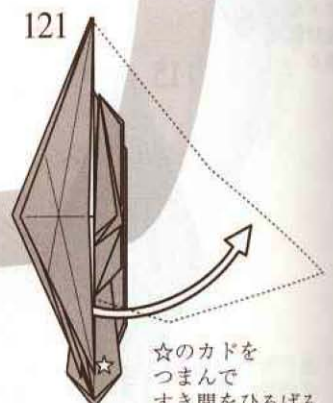

☆のカドを  
つまんで  
すき間をひろげる



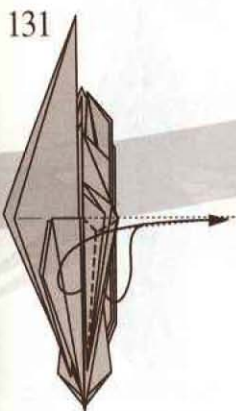

131  
カドをつまむ  
ように折る

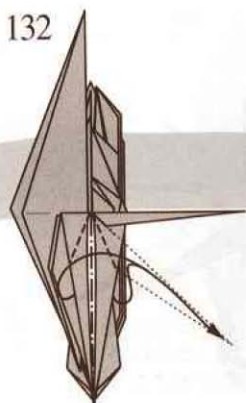

132  
カドをつまみながら  
カドを反対側に折る

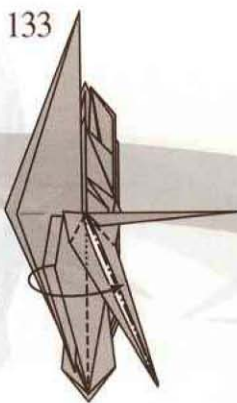

133  
途中の図

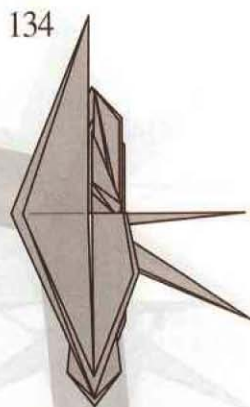

134  
反対側も  
106~133と同じ

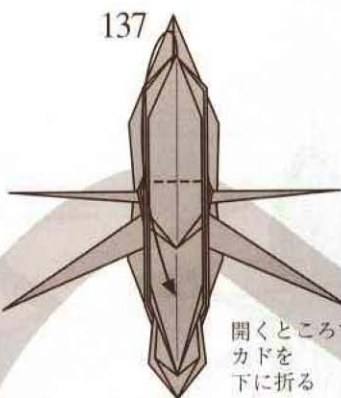

137  
開くところで  
カドを  
下に折る

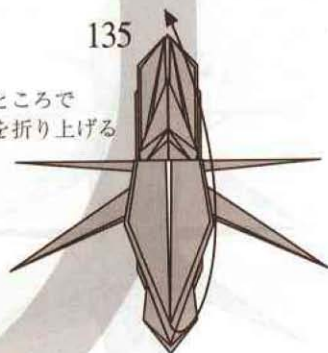

135  
開くところで  
カドを折り上げる

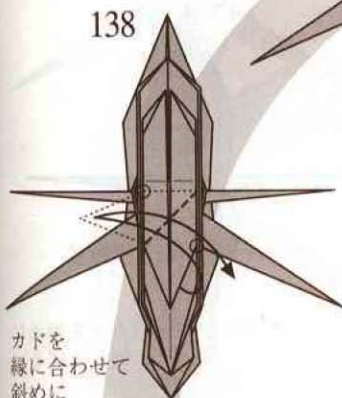

138  
カドを  
縁に合わせて  
斜めに  
折り筋を  
つける

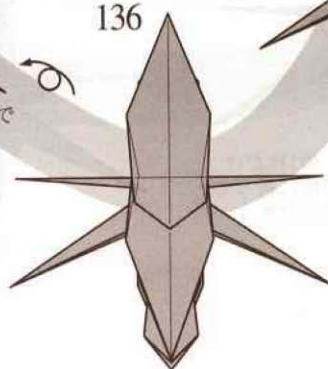

136

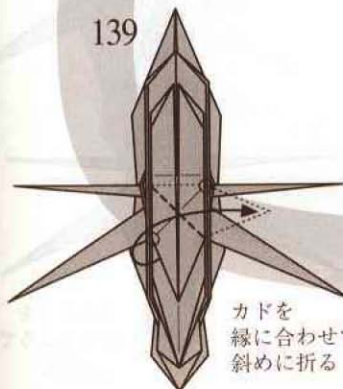

139  
カドを  
縁に合わせて  
斜めに折る

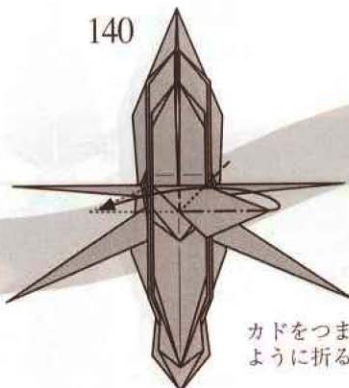

140  
カドをつまむ  
ように折る

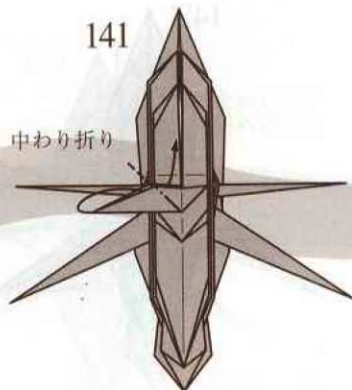

141  
中わり折り

149

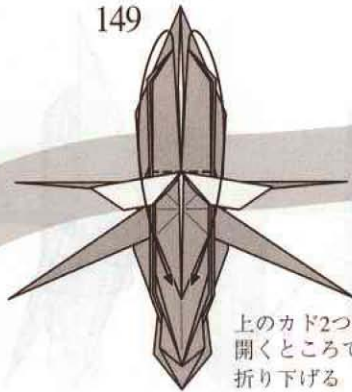

上のカド2つを  
開くところで  
折り下げる

150

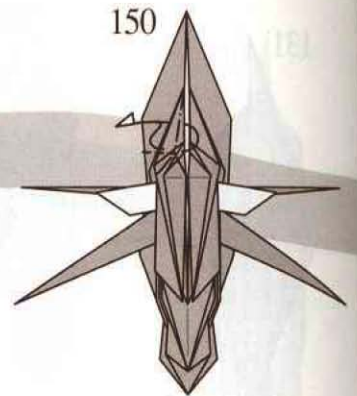

カドをつまむように  
後ろへ折る

148

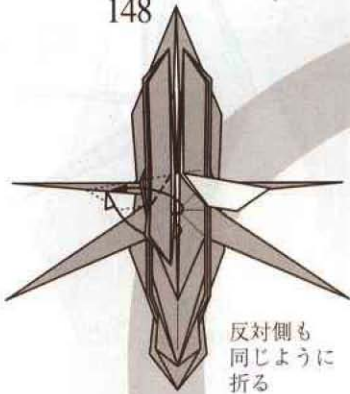

反対側も  
同じように  
折る

147

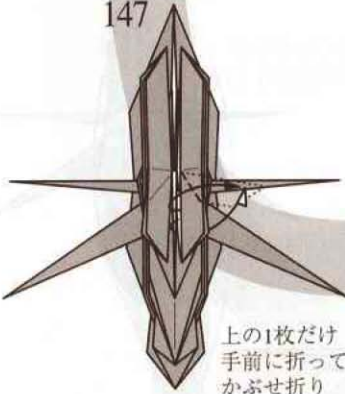

上の1枚だけ  
手前に折って  
かぶせ折り

146

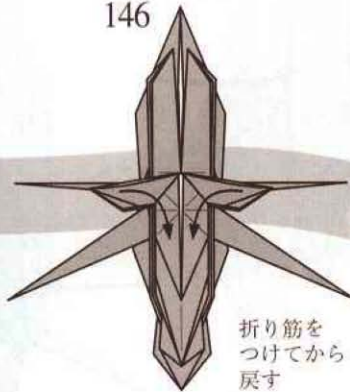

折り筋を  
つけてから  
戻す

145

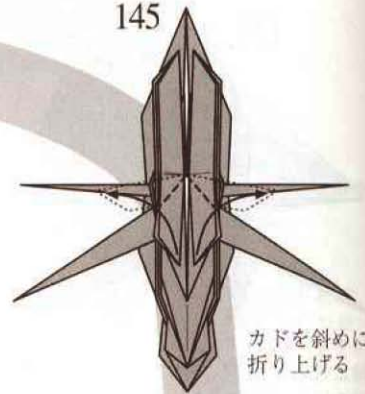

カドを斜めに  
折り上げる

142

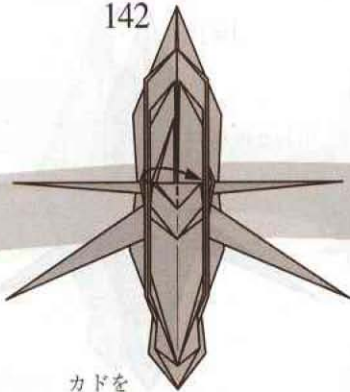

カドを  
反対側に折る

143

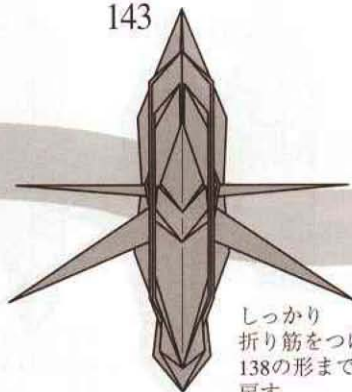

しっかり  
折り筋をつけて  
138の形まで  
戻す

144

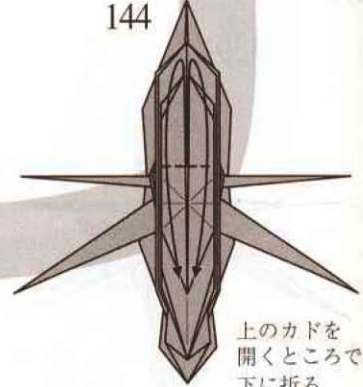

上のカドを  
開くところで  
下に折る

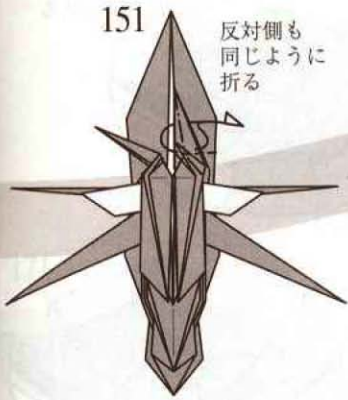

反対側も  
同じように  
折る

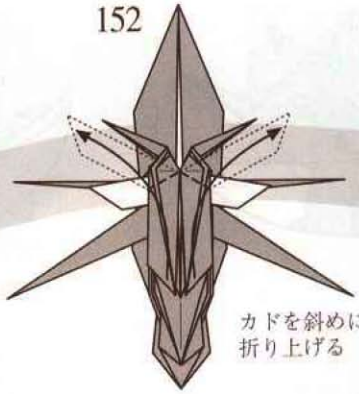

カドを斜めに  
折り上げる



折り筋を  
つけてから  
戻す

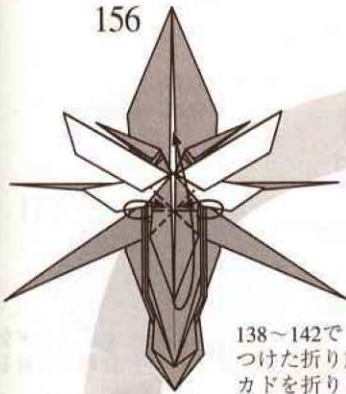

138~142で  
つけた折り筋で  
カドを折りまとめながら  
かぶせるように折る

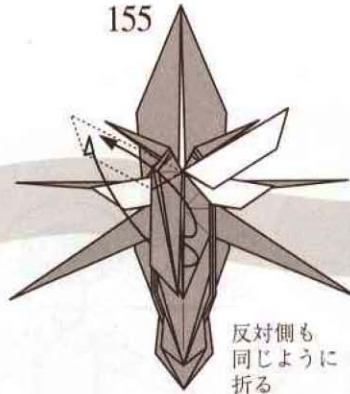

反対側も  
同じように  
折る

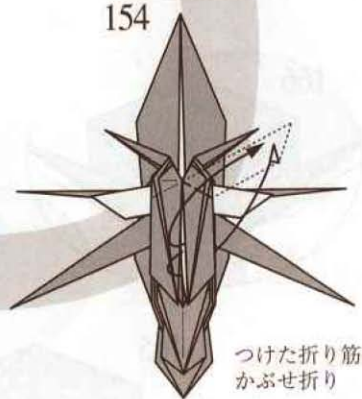

つけた折り筋で  
かぶせ折り

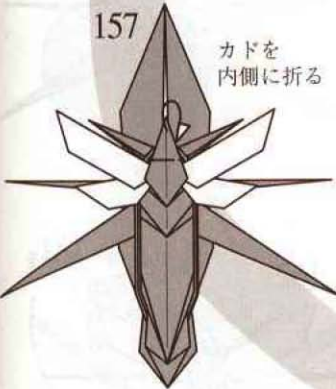

カドを  
内側に折る

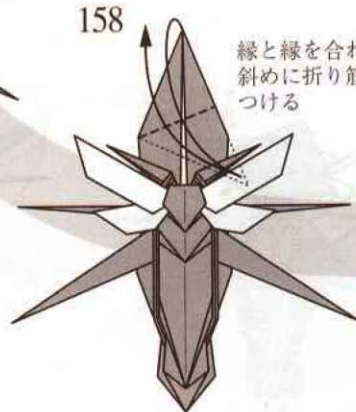

縁と縁を合わせて  
斜めに折り筋を  
つける

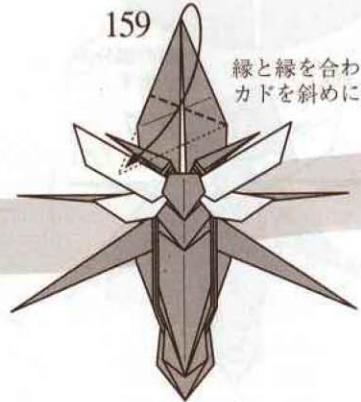

縁と縁を合わせて  
カドを斜めに折る

黒矢印の部分を  
押し込むように  
内側をひろげて  
■の部分をつ  
いている折り筋で  
折りまとめる

168

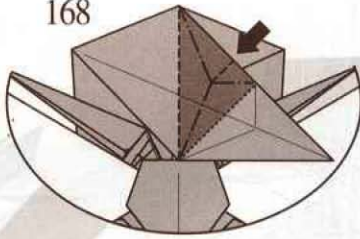

内側をひろげて  
つぶすように折る

169

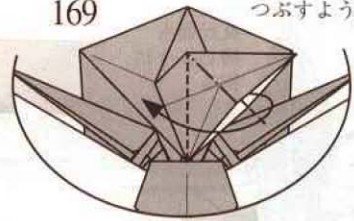

167

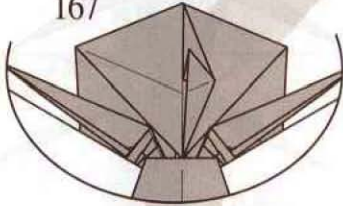

しっかりと  
折り筋をつけて  
163の形まで戻す

170

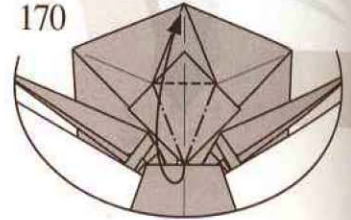

内側をひろげて  
つぶすように折

166

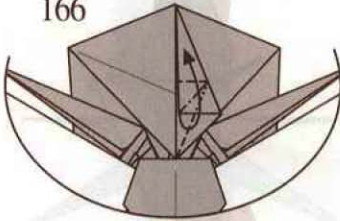

カドをつまむ  
ように折る

164

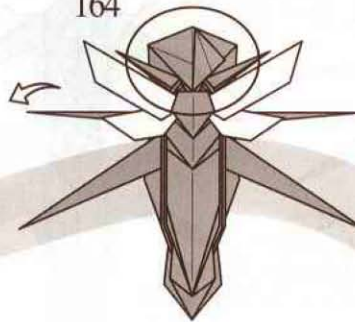

165

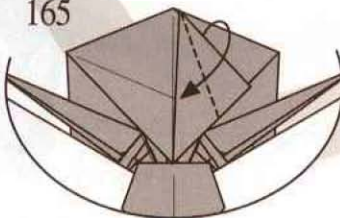

縁と縁を  
合わせて折る

163

カドとカドを  
合わせて折る

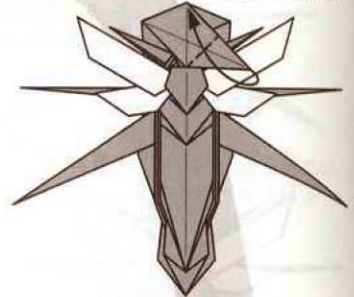

[www.japaoburajirujin.blogspot.com](http://www.japaoburajirujin.blogspot.com)

160

内側の部分を  
引き出す

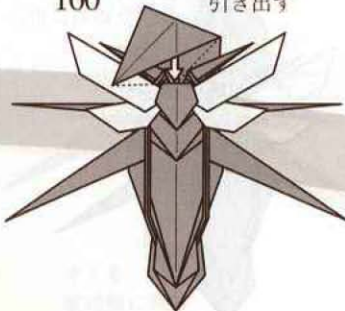

161

カドをつまむ  
ように折る

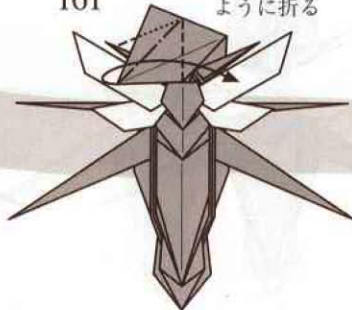

162

内側の部分を  
引き出す

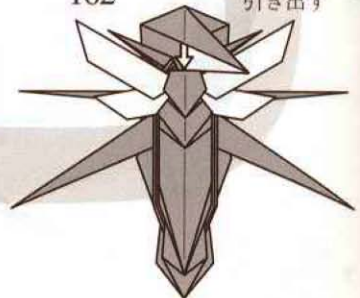

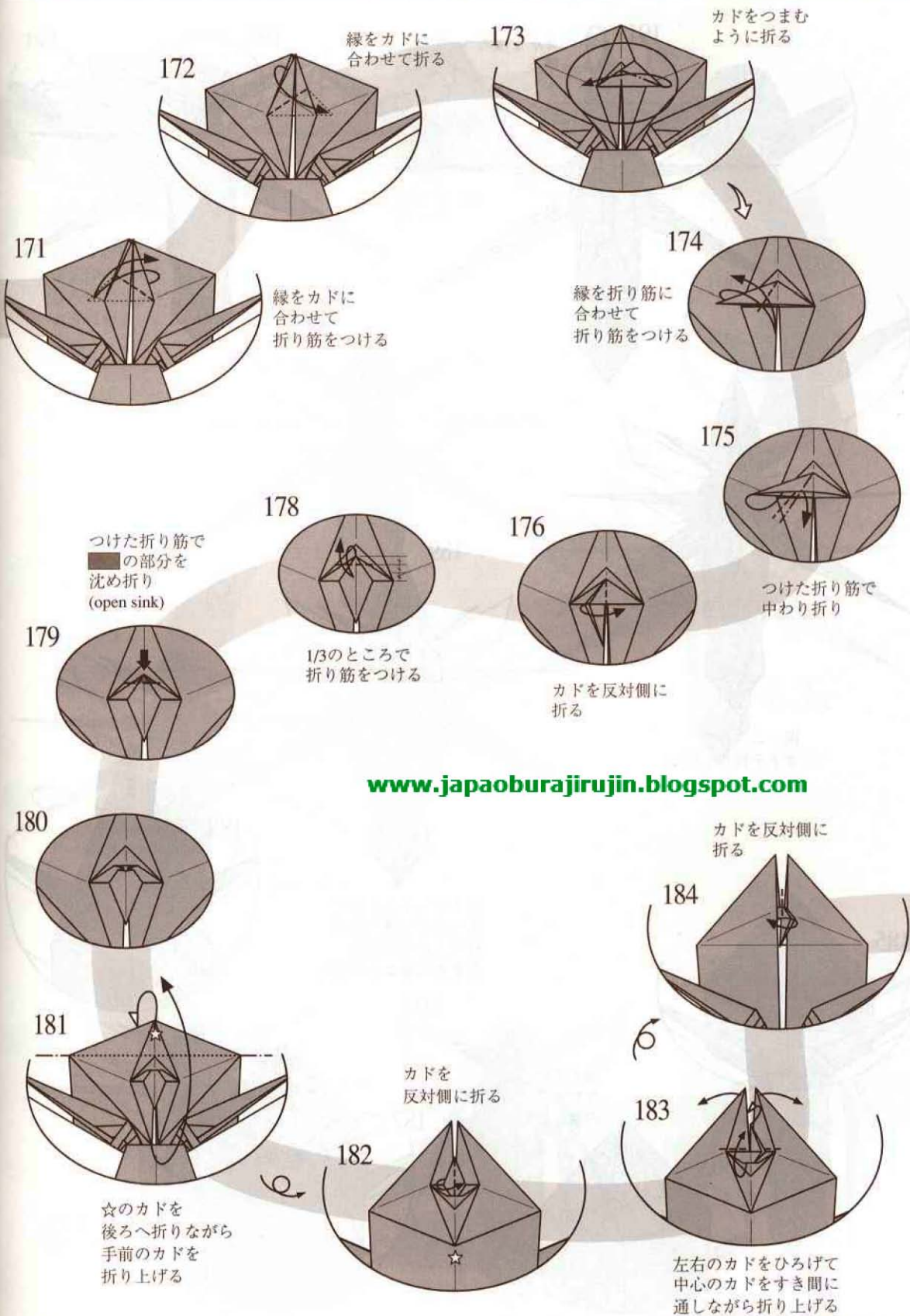

[www.japaoburajirujin.blogspot.com](http://www.japaoburajirujin.blogspot.com)

191 カドを後ろへ折る

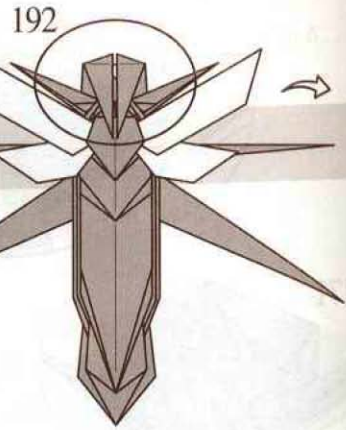
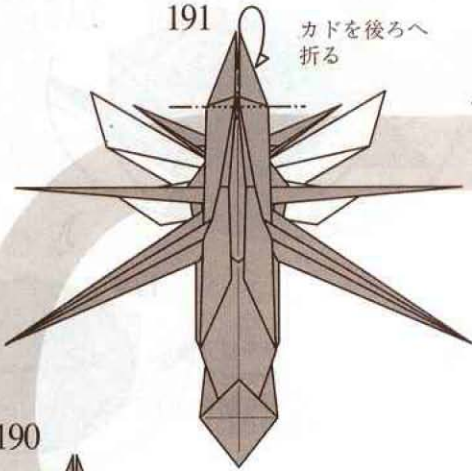

190

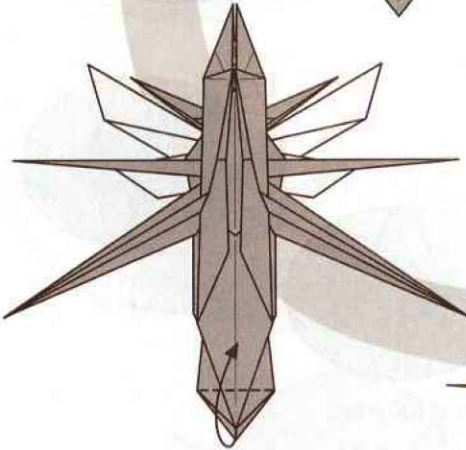

開くところでカドを折り上げる

[www.japaoburajirujin.blogspot.com](http://www.japaoburajirujin.blogspot.com)

189

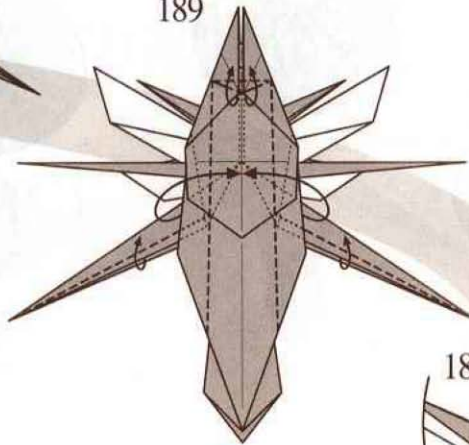

カドをつまむように折りながら連られて持ち上がる部分を引き寄せるように折る

188

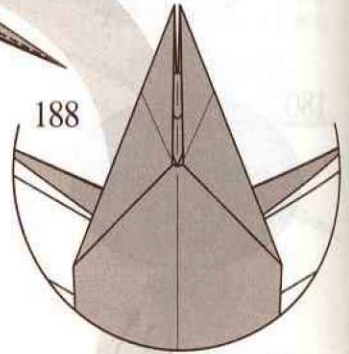

カドを中心に合わせて折る

185

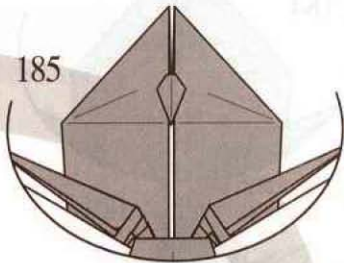

縁をを中心に合わせて内側に折る

186

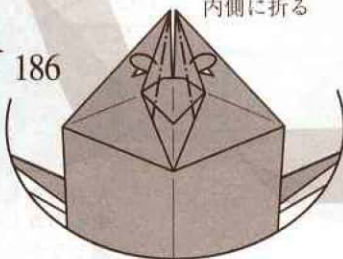

187

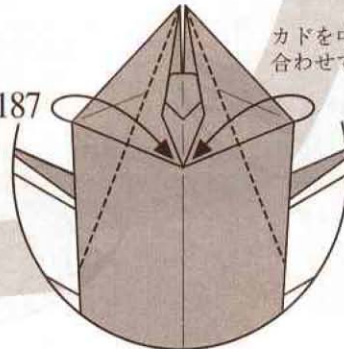

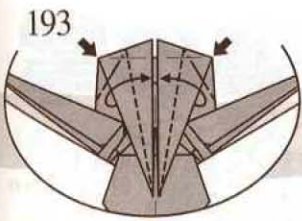

縁を中心に合わせ  
て  
折りながら  
黒矢印の部分  
ひろげてつぶす  
ように折る

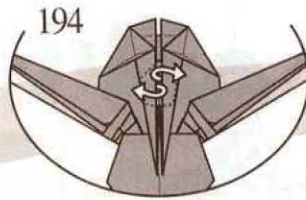

内側の部分を  
外に出す

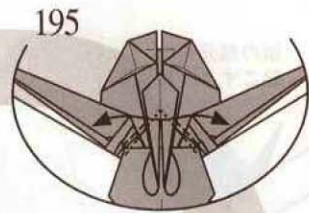

中わり折り

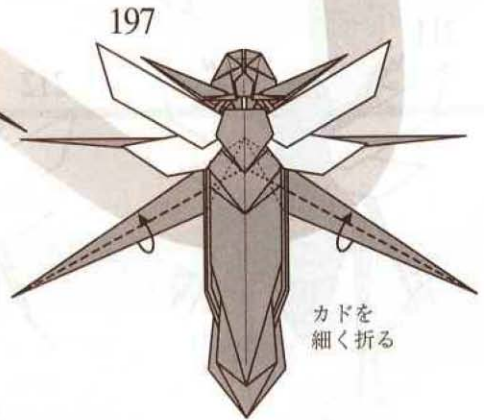
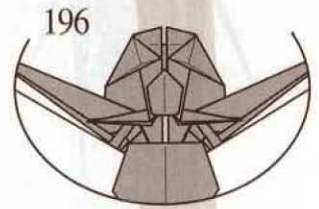
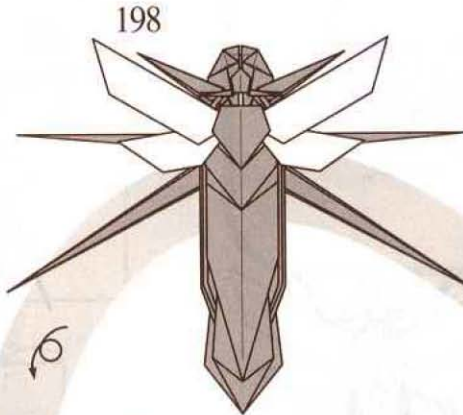

カドを  
細く折る

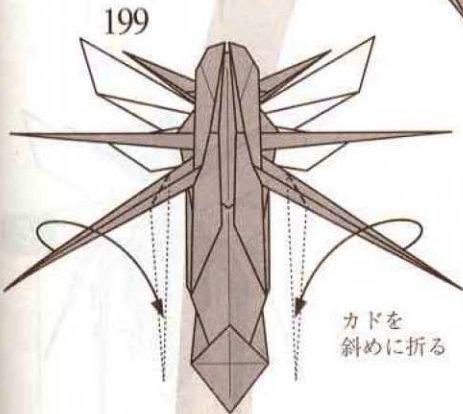

カドを  
斜めに折る

[www.japaoburajirujin.blogspot.com](http://www.japaoburajirujin.blogspot.com)

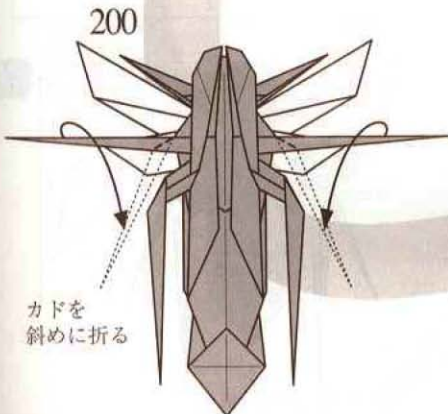

カドを  
斜めに折る

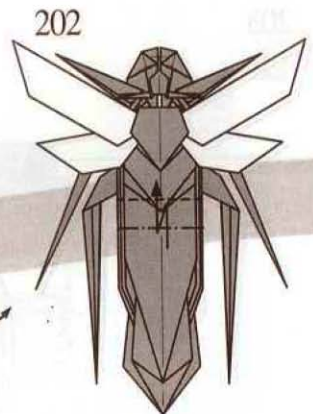
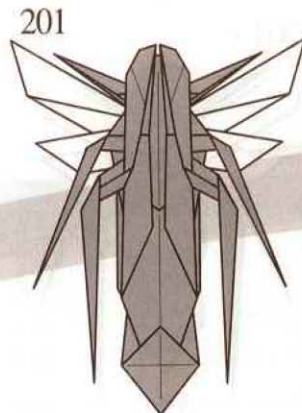

段折り

210

頭の部分を  
起こすようにする

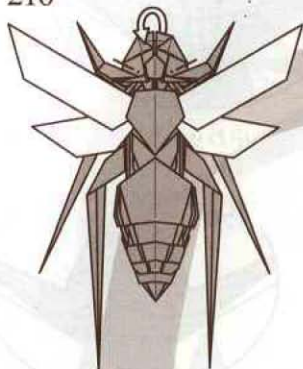

209

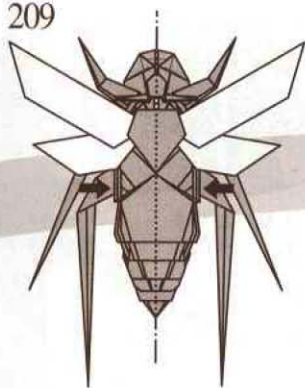

黒矢印の部分を  
左右からつまんで  
立体になるように  
形を整える

208



前脚を  
斜めに段折り

207

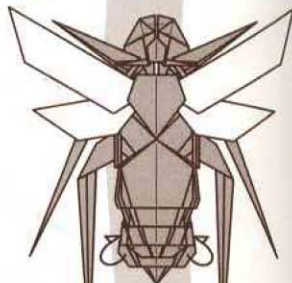

カドを  
内側に折る

211

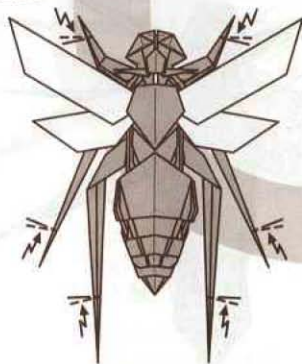

脚の先を  
斜めに段折り

212

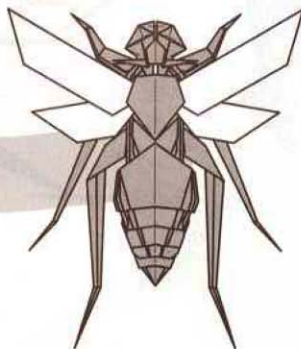

できあがり

206

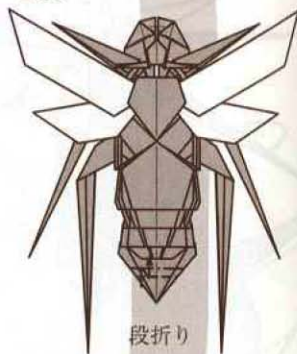

段折り

[www.japaoburajirujin.blogspot.com](http://www.japaoburajirujin.blogspot.com)

203

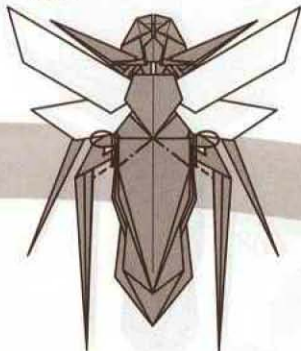

カドを  
内側に折る

204

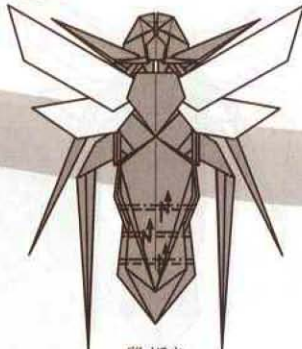

段折り

205

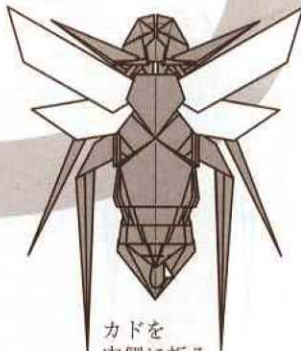

カドを  
内側に折る



# 掌の中の小鳥

創作 2001/1/25

作図 2003/8/3

作/図 渡辺 大

Model and Diagrams by *Dai Watanabe*

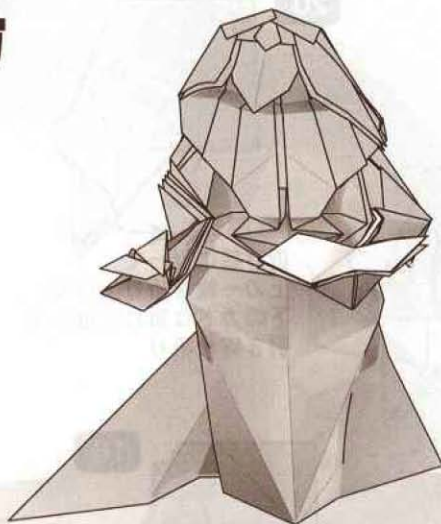

[www.japaoburajirujin.blogspot.com](http://www.japaoburajirujin.blogspot.com)

1

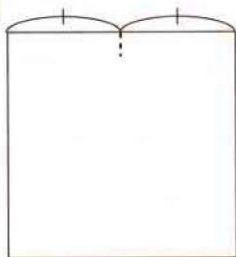

2

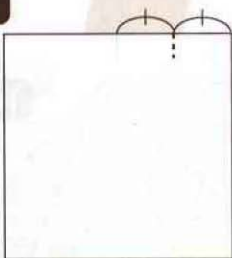

3



4

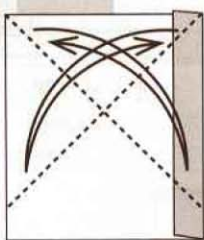

ご参考までに...(1)  
1/8 という分割は近似的なものです。理想的な分割に比べると、紙の大きさに対して1%以下の誤差が生じます。この誤差が意味を持つのは本を折り出す時だけなのですが、この誤差を許せない方は理想的な分割を与える方法を追求してみてください。

5

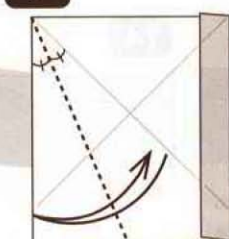

6

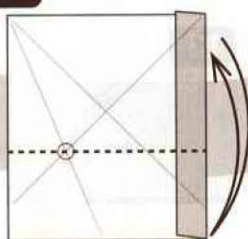

7

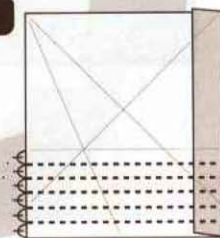

6等分の折り線をつける

9



90°

8

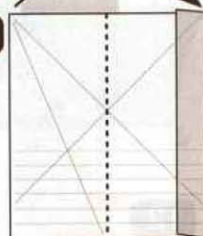

半分に折る

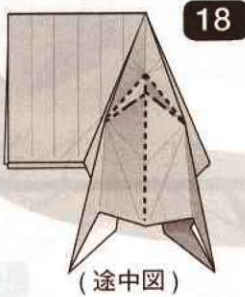
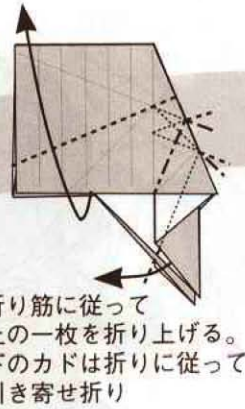
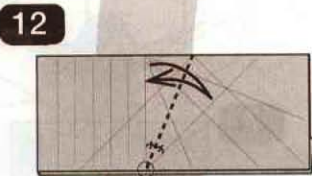
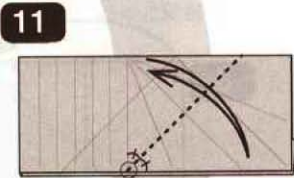
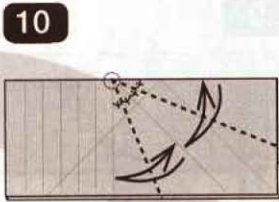
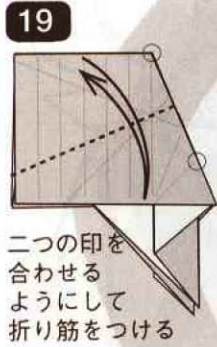

[www.japaoburajirujin.blogspot.com](http://www.japaoburajirujin.blogspot.com)

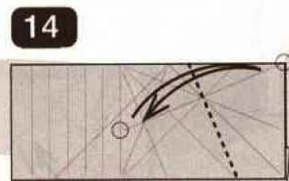
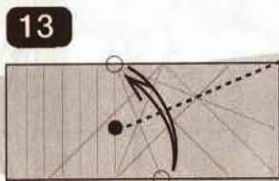
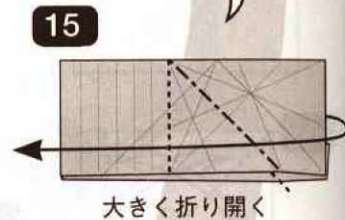
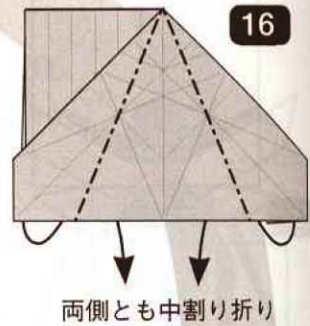
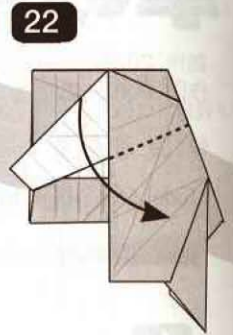
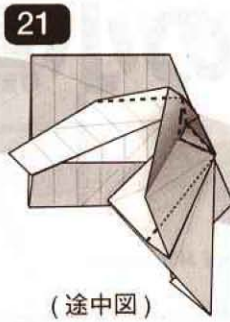
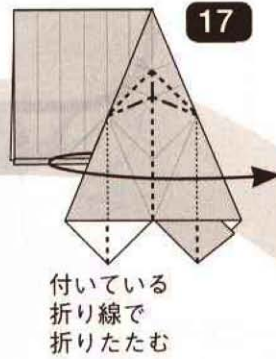

23

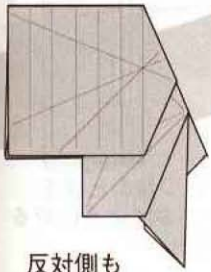

反対側も  
同じに折る

24

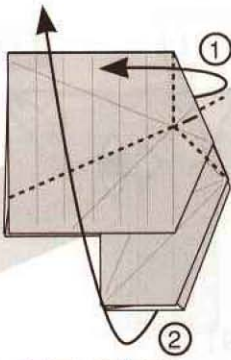

1. 上から2枚目のヒダで折り開く
2. 一番下だけ残して付いている折り線で折り上げる

25

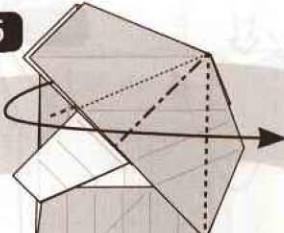

上の1枚を折り開く

26

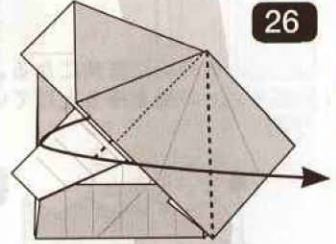

次の1枚も折り開く

27

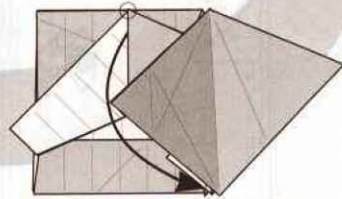

色の濃い部分を持ち上げて  
○印のついたカドを  
引き下ろす

28

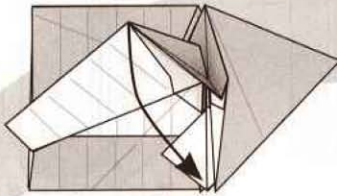

(途中図)

29

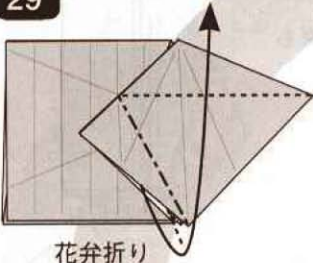

花弁折り

30

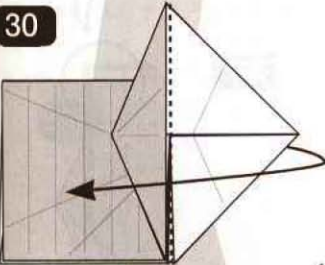

31

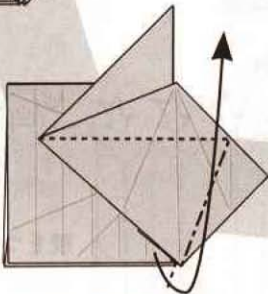

こちら側も花弁折り

32

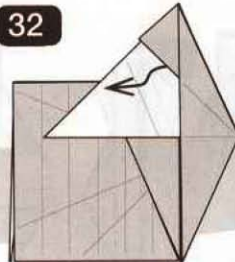

中に折り込まれている  
紙を引き出す

34

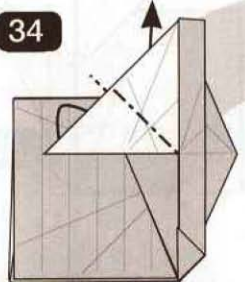

開いてつぶすように折る

33

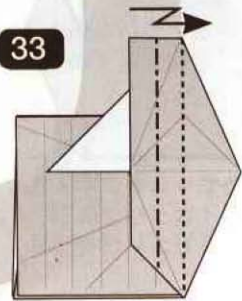

44

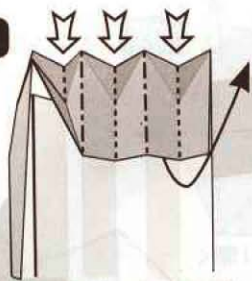

下の紙に直角になるように  
上の紙を持ち上げていく

45

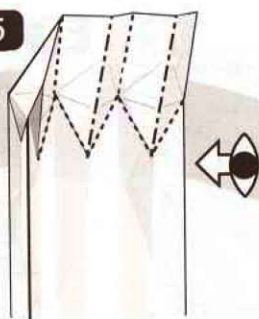

(途中図)

46

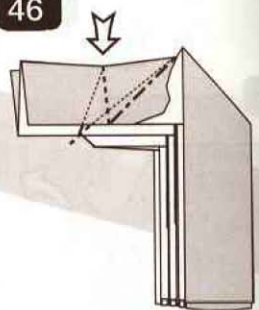

2つ目のヒダを  
つぶすように折る

43

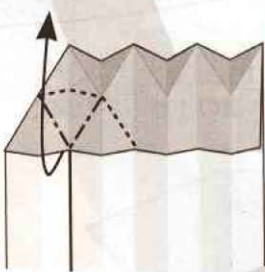

42

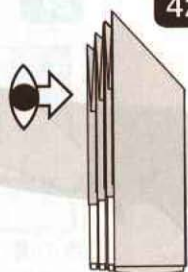

41

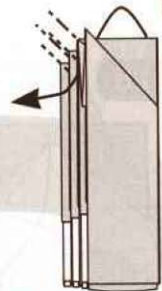

残り二つのヒダも  
同様に折る

40



中割折り

35

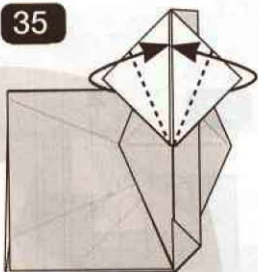

36

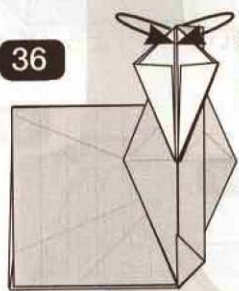

後ろに隠れている  
カドを手前に  
引き出す

39

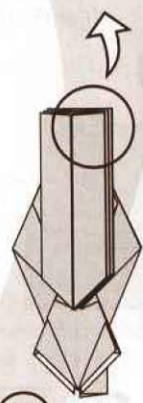

37

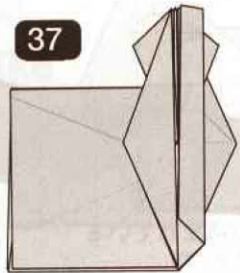

38

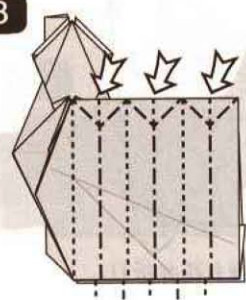

稜をつぶすように  
しながら段折り

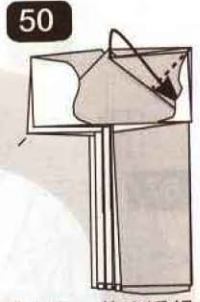
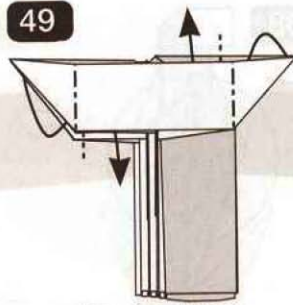
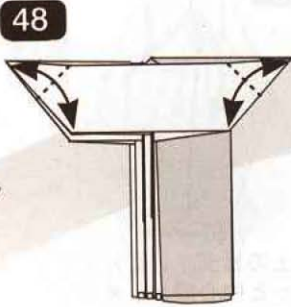
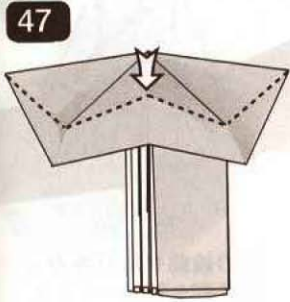

両側とも中割折り  
左右で折り込む  
向きが違います

(一番上の一枚を透視)  
48 でつけた折り筋で  
奥に折り込む  
(止め折りです)

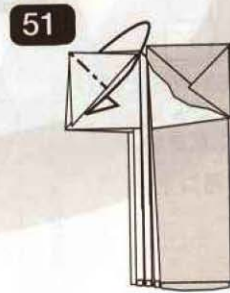
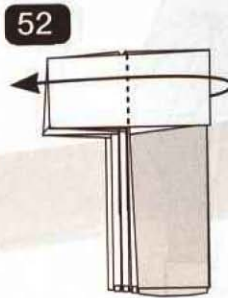
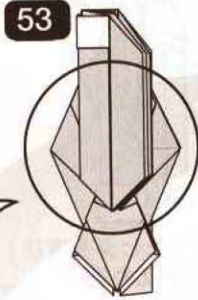
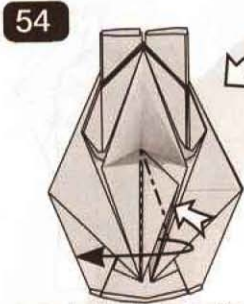

(これも透視です)  
今度は向こう側に  
折り込む

(上のカドを持ち上げた状態)  
山をつぶすように折る

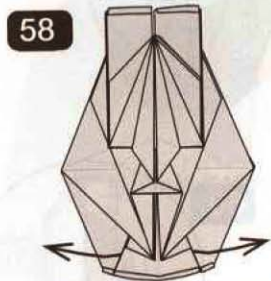

後ろに巻き込んだる  
紙を引き出す



一枚後ろのヒダを  
真ん中に引き寄せ  
ながら段折り

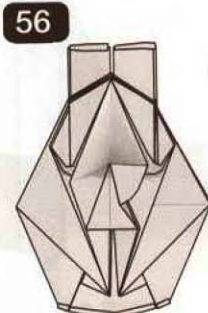

反対側も同じ

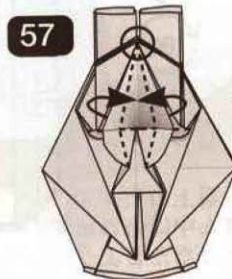

一番上のヒダを  
真ん中に合わせながら  
○印のついたカドを  
目一杯折り上げる

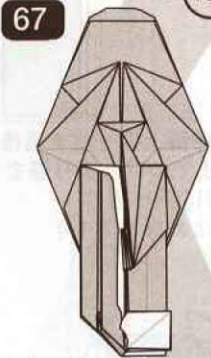

67

反対側も 63~66 と同じ  
(2 の open sink は  
無視してください)

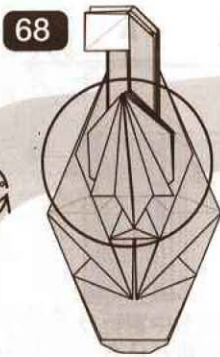

68



69

一番上のヒダだけ折ります。  
ちょっと中心線から外れて  
いるのに注意してください。

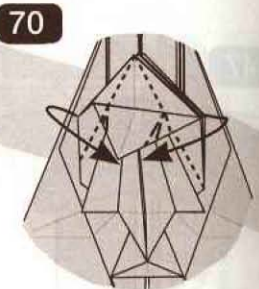

70

顔の輪郭を取りながら  
引き寄せ折り

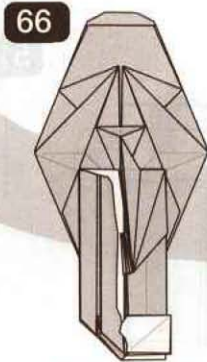

66

下のヒダも同じ

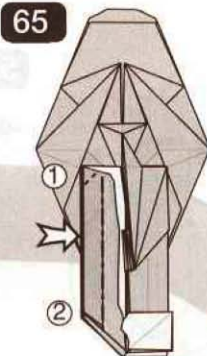

65

(64 で折ったヒダを透視)  
次のヒダを沈め折り  
(1 は closed sink,  
2 は open sink)

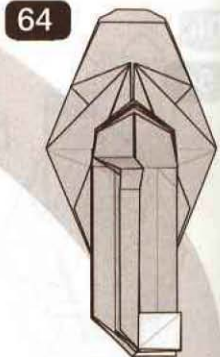

64

(途中図)

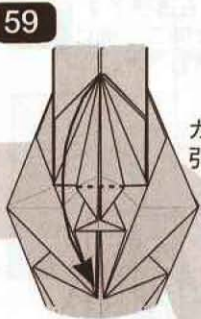

59

カドをまとめて  
引き下ろす

ご参考までに...(2).  
69以降の行程は顔の折り出しなので  
ぐらい折りばかりです。  
各自工夫してください。  
また、70で顔の角度が傾くのは  
「小鳥を見る」ポーズをつけるためです。

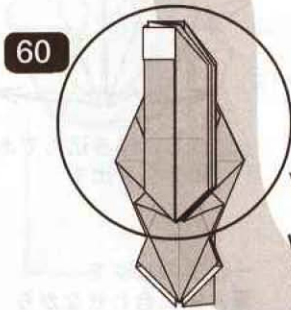

60

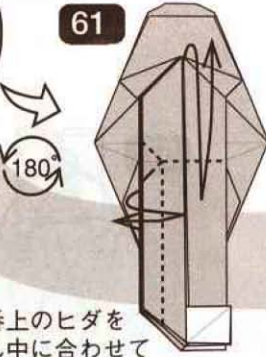

61

一番上のヒダを  
真ん中に合わせて  
折りたたむようにして  
折り筋をつける



62

下2枚と左側のヒダも  
同様の折り筋をつける

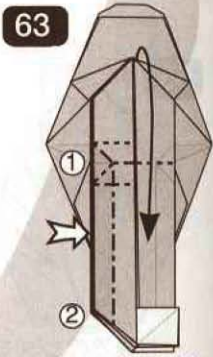

63

1と2を沈め折り  
(open sink) しながら  
上のカドを畳みこむ



71

カドを一枚だけ  
つまみ折り



72

つまんでできたカドを  
開いてつぶすように折る

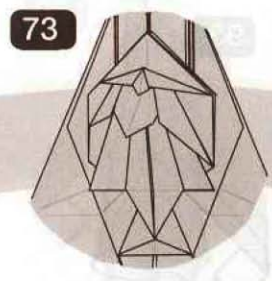

73

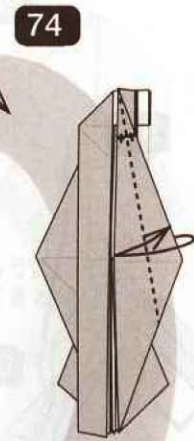

74

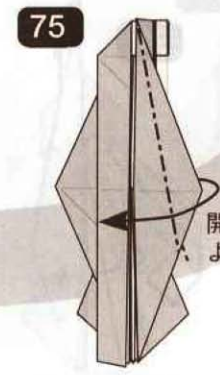

75

開いてつぶす  
ように折る

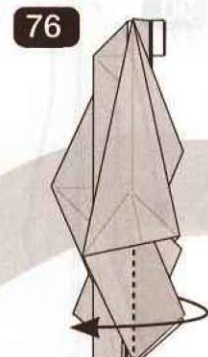

76

中のヒダを1枚だけ  
折り開く

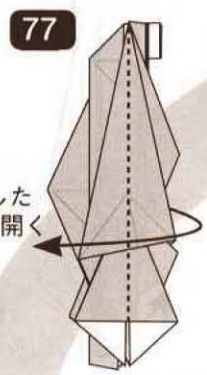

77

75でつぶした  
ヒダを折り開く

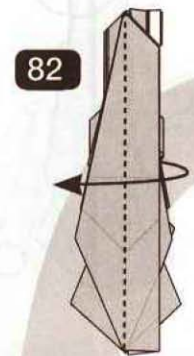

82

上の1枚だけ折る

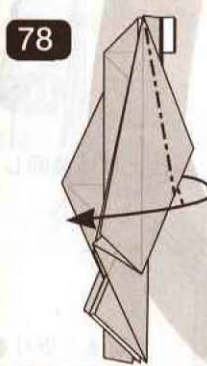

78

次のヒダも開いて  
つぶすように折る  
(引っかかる場所が  
あります。  
次図を参考にして  
カドをつぶしながら  
折ってください)

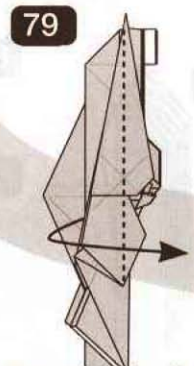

79

74~78で折ったヒダ  
(3枚)を元に戻す

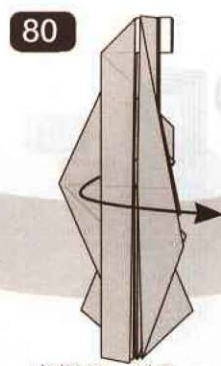

80

左側のヒダを  
1枚だけ折り開く

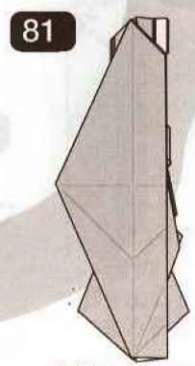

81

左側も74~79と  
同じように折る



93

94

上から2枚目で  
中割折り

95

引き寄せ折り

91

引き寄せ折り

90

付け根から折り  
下げる

89

88

仕上げは後回し

87

同様の折りを  
2回繰り返す

86

2つ目のカドをつぶしながら  
1つ目のカドを引き下げる

85

残りの5つのヒダも  
同様に折る

84

83

印を結ぶ線で  
折り筋をつける

92

ご参考までに... (3) ...  
 しまった... 小鳥の折り出しは67の  
 後に入れるべきでした。書き直す気力  
 が残っていないのでここに入れます。  
 ご参考までに、私は最後の仕上げと一  
 緒に折っています。



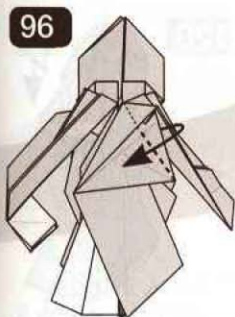

96

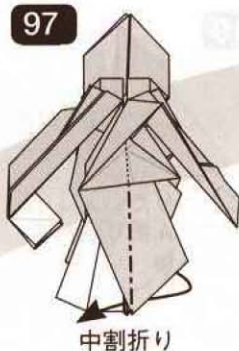

97

中割折り

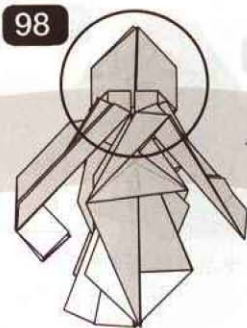

98

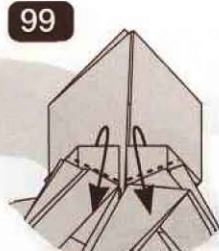

99

もうこの辺からは  
てきとうに...

[www.japaoburajirujin.blogspot.com](http://www.japaoburajirujin.blogspot.com)

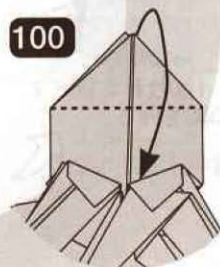

100

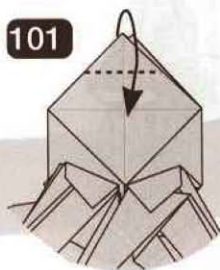

101

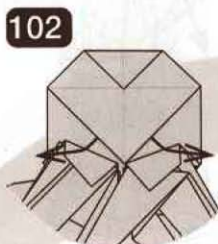

102

中の紙をずらすように  
して引き出す

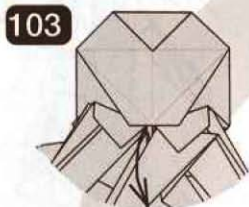

103

ヒダを下にひっぱる  
ように折る  
(西川虎折り)

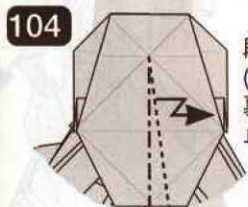

104

段折り  
(立体化します)  
裏でてきとうに  
止め折り



108

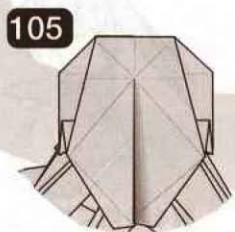

105

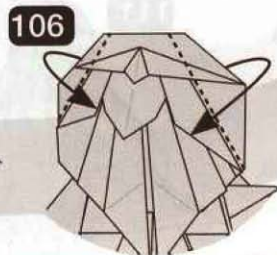

106

上のヒダの縁に沿って折る

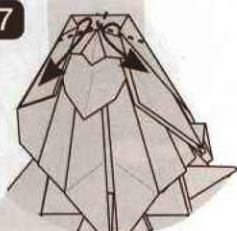

107

両側のカドを  
引き出しなが  
らつまみ折り

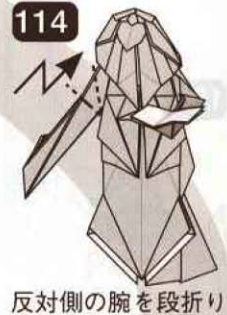
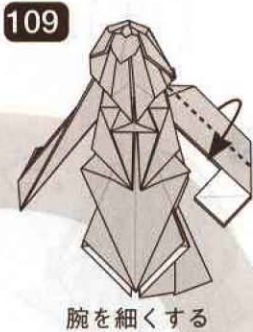
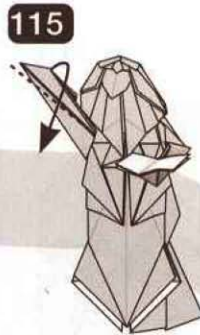
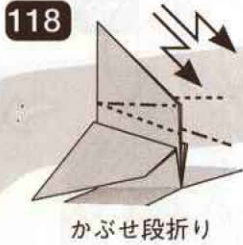

.....ご参考までに...(4).....  
 111 以降の行程は立体工程になります。造形的にかなり苦しいです...  
 折りにも無理があり、ウェットフォルディングなどを使わないと形が決まりません。  
 工程 115 では、自然に発生する立体 (小鳥より先の部分が平面にならない) を利用して掌を表現しています。

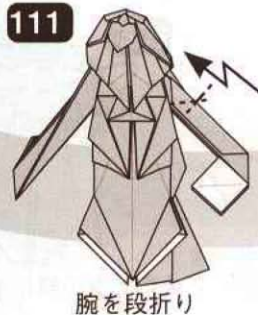
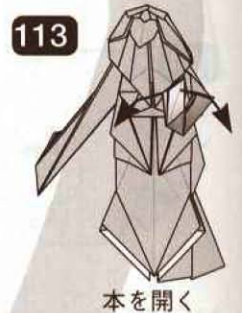

121

下に隠れているヒダを  
カーブさせながら腰を  
成形する

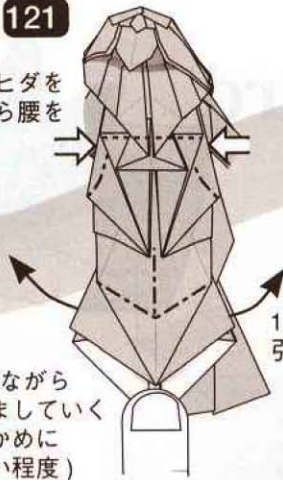

1枚下のヒダを  
引き出す

中に指を入れながら  
スカートを膨らましていく  
折りは柔らかめに  
(線をつけない程度)

122

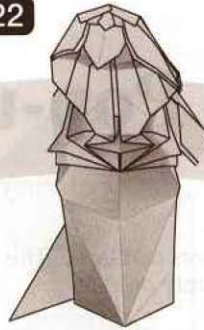

123



白い部分を中割折り

124

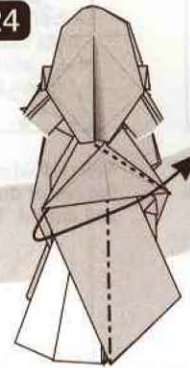

スカート部分を  
持ち上げていく

125

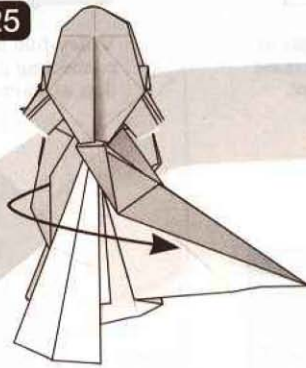

126

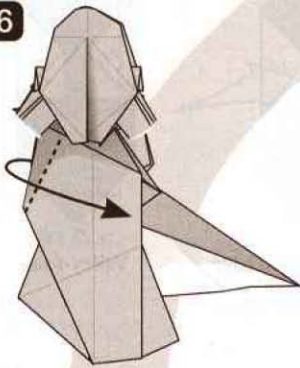

引き寄せ折り

ご参考までに...(5)  
スカートの仕上げ(膨らまし方、紙の重なった部分の処理など)は省略しています。  
力尽きた、というのが本音ですが、私自身、未だ同じ物を折ったことが無いのです。  
試行錯誤して自分の好みを探してみてください。

127

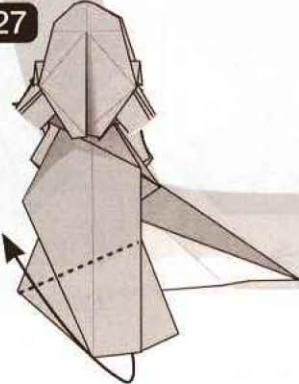

128

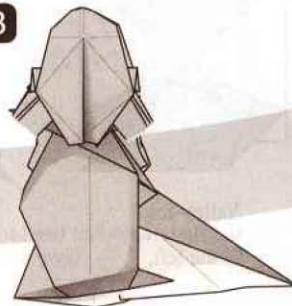

スカートを膨らませながら  
形を整える

129



できあがり

# Peacock Pop-up Card

by Jeremy Shafer ©2001

Let go of the scissors and tape. This Peacock Pop-up Card is purely origami.

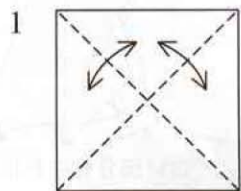
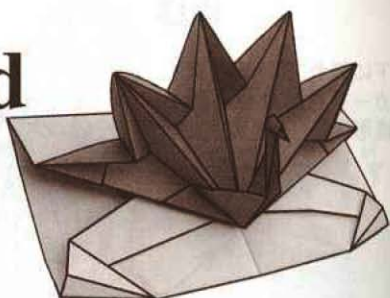

1 Valley-fold and unfold diagonally both ways.



2 Valley-fold each edges to the center diagonal crease and unfold. Turn over.

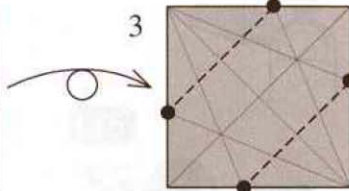

3 Valley-fold and unfold connecting the black dots as shown.

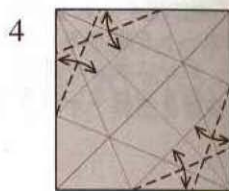

4 Valley-fold and unfold.

[www.japaoburajirujin.blogspot.com](http://www.japaoburajirujin.blogspot.com)

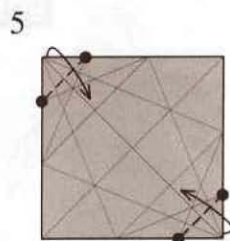

5 Valley-fold and unfold connecting the black dots.

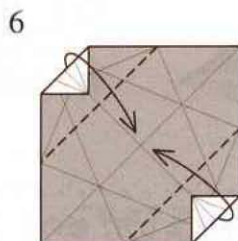

6 Valley-fold on the existing creases.

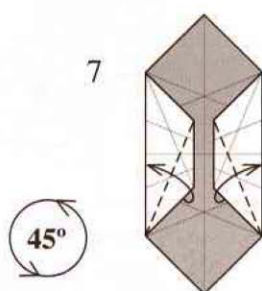

7 Valley-fold edge to edge letting the two hidden corners swing into view.

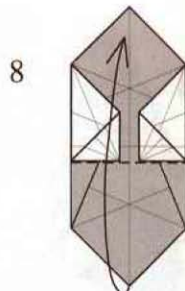

8 Valley-fold.

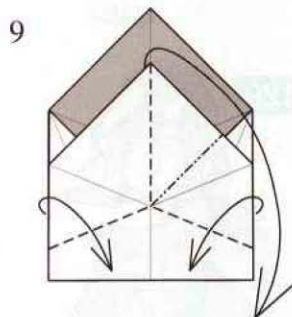

9 Rabbit-ear flattening the flap rightward. The valleys are on existing creases.

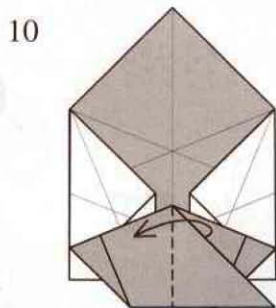

10 Valley-fold the flap over to the left.

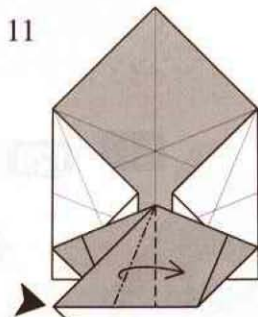

11 Squash!

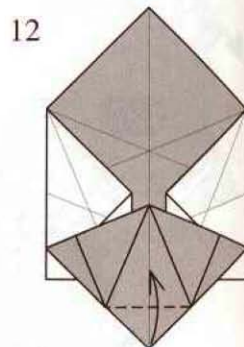

12 Valley-fold.

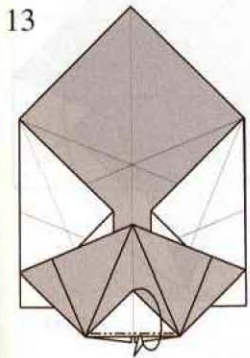

13 Unfold the flap and insert it into the pocket.

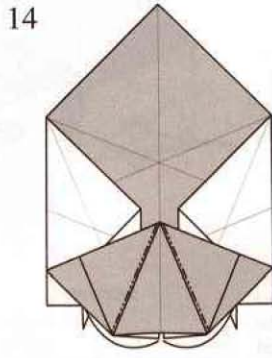

14 Mountain-fold, swinging the two hidden flaps apart.

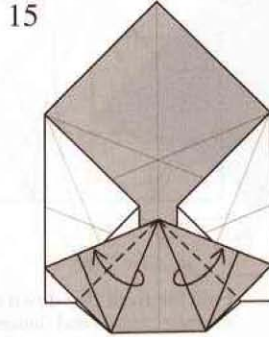

15 Valley-fold the flaps further apart. Think about Jacob's Ladder.

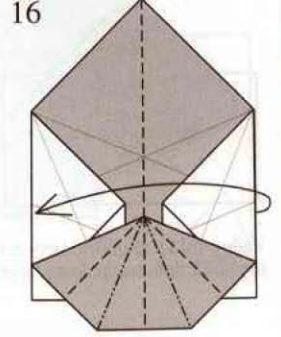

16 Valley-fold in half pleating the front layer. These pleats will become the peacock's tail feathers.

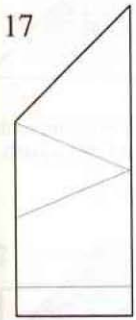

17 Like this.

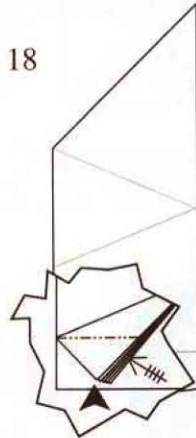
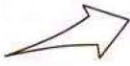

18 Tear-away view. Reverse-fold the central five points, starting with the middle point. The folds are horizontal.

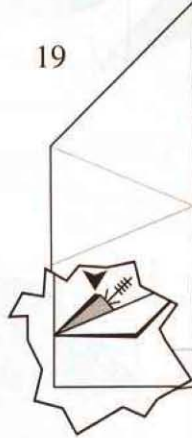

19 Reverse-fold the five flaps back the other way.

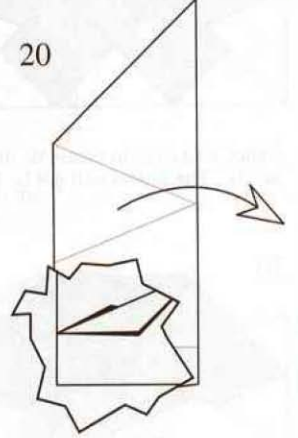

20 Open the card and flatten the tail feathers bringing the model back to how it looked in step 16

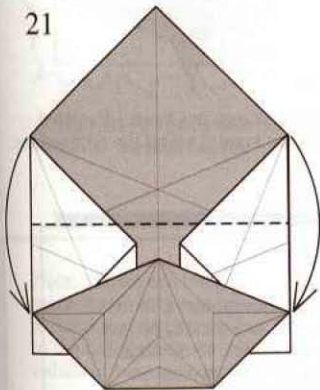

21 Valley-fold.

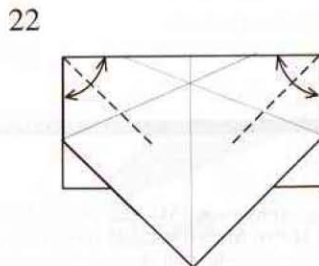

22 Valley-fold and unfold on the front layer.

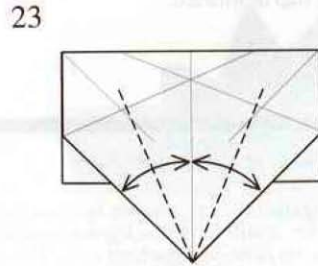

23 Valley-fold and unfold on the front layer. These creases should extend at least to the creases made in the previous step. Rotate the model 180°.



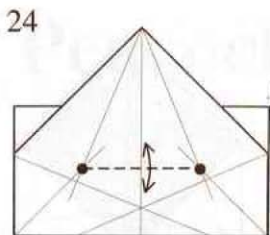

24  
Valley-fold and unfold between the black dots on the front layer.

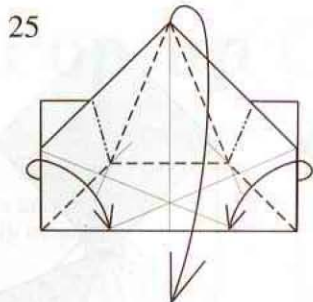

25  
Fold the front flap down on the existing creases and flatten. The two mountain folds get formed in the flattening.

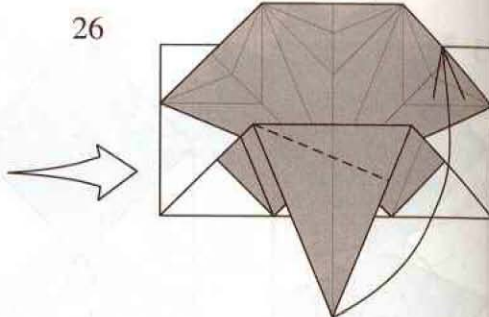

26  
Valley-fold the flap upward and to the right

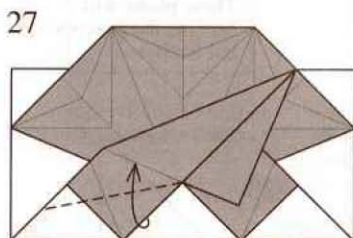

27  
Valley-fold edge-to-crease on the front layers. The model will not lie flat.

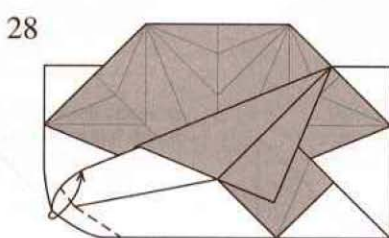

28  
Valley-fold the corner on to indicated edge and flatten.

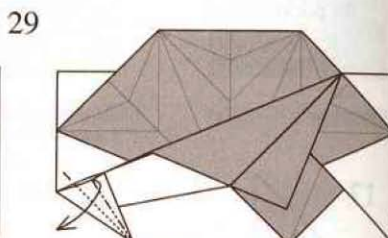

29  
Pull the front edge downward to the left as far as it will go and squash.

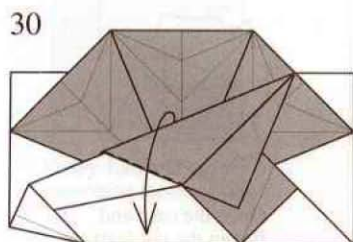

30  
I see the folds made in steps 27-30 as the shadow of the peacock's head and neck, or perhaps its alter ego. Valley-fold the flap downward.

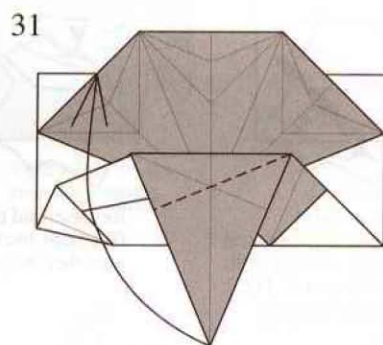

31  
Repeat steps 26-30.

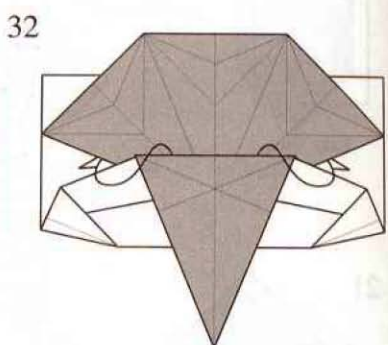

32  
Another alter ego has been identified. Put the front layers behind the tail feathers.

### Thoughts Behind the Folds.

Folding origami pop-up cards has been an ongoing exploration. My idea is that if you can incorporate a model into a pop-up, it will have much more appeal and utility. Sure you could just paste a model into a card, but we origami purists must do it the hard way. This particular pop-up of a peacock has undergone extensive evolution. The original version was quite rough but nevertheless I decided to teach it at the OrigamiUSA Convention 2000 on the assumption that I would be able to refine it in time. But it was much harder than I had anticipated and I found myself banging my head on the problem all the way to New York and even while teaching the class itself, which, just my luck, was soldout. I told everyone I would find a nicer version, diagram it and put it in BARF. So now, more than a year later, here it is.

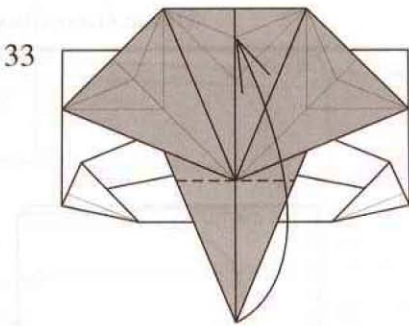

33 Valley-fold the flap upward.

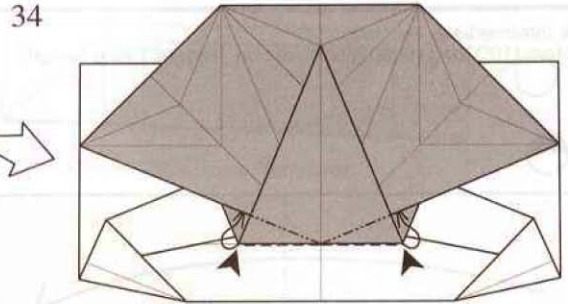

34 Reverse-fold inserting the paper into the pockets.

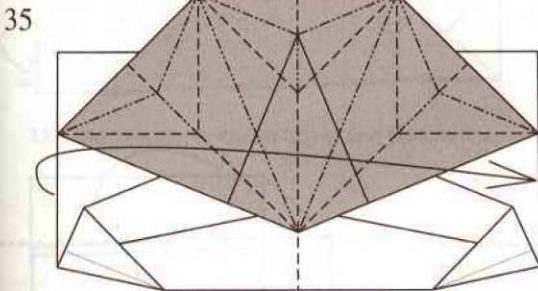

35 Fold the card in half, refolding the tail feathers as they were in step 20, but this time make the folds go through the top flap too as if it were part of the same layer.

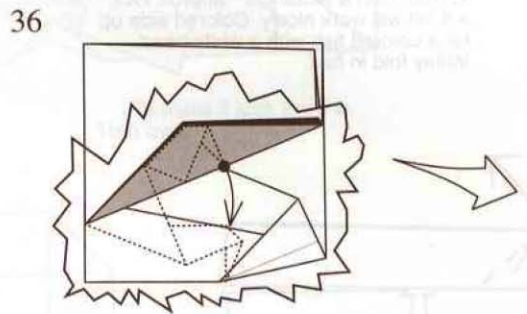

36 Cut-away view. Pull the peacock's beak downward.

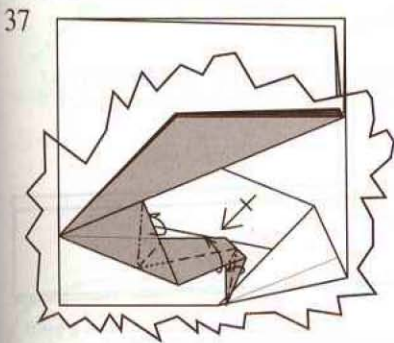

37 Narrow the neck with swivel folds. Repeat behind.

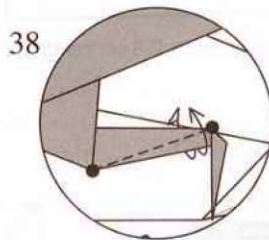

38 Outside-reverse-fold the neck. This fold extends between black dots on both sides. Let the folds on the head open and redefine themselves.

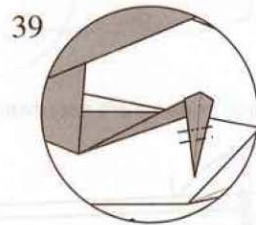

39 Crimp to form the beak.

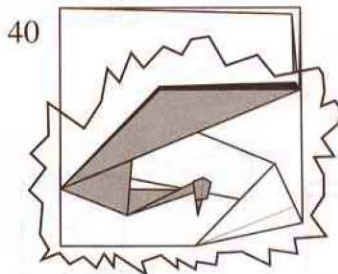

40 The Peacock Card is complete. Open it and so the peacock can strut its stuff.

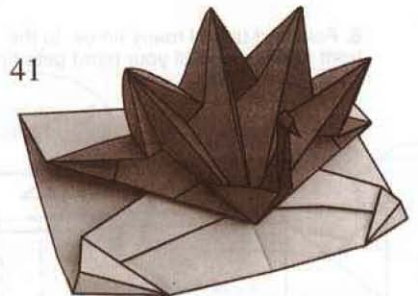

41 The Peacock is open, single, available, and looking to impress some hot peachicks.

Note: There are many much more intricate pleat patterns that can be applied to the tail feathers to enhance their appearance.

# ♪ The Singing Fish ♪

© Gilad Aharoni (Israel) 2002

Low Intermediate

A 24cm (10") long rectangle makes an 11cm (4") long model.

[www.japaoburajirujin.blogspot.com](http://www.japaoburajirujin.blogspot.com)

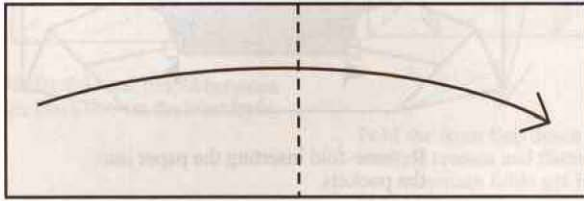

1. Start with a rectangle - approx 1X3, a \$ bill will work nicely. Colored side up for a colored fish with a white head. Valley fold in half.

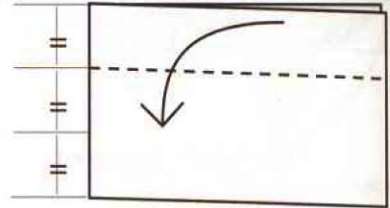

2. Fold a 1/3 down.

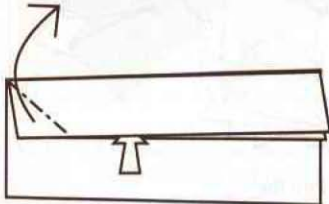

3. Squash fold.

2-3

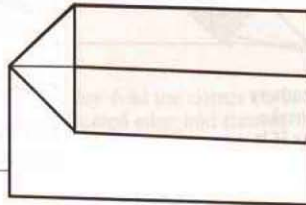

4. Repeat steps 2-3 on the bottom.

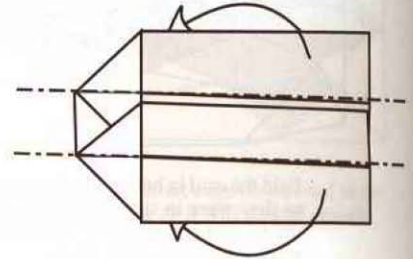

5. Mountain fold top and bottom.

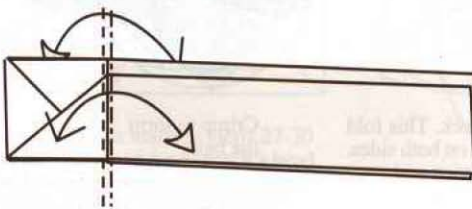

6. Fold and unfold many times, to the front and back, until your hand gets tired. Crease very firmly.

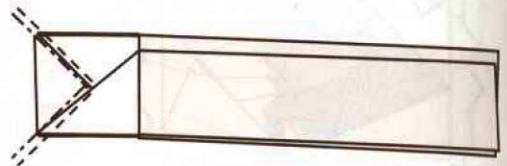

7. Fold and unfold many times, to the front and back, until your hand starts to really hurt. Crease very firmly.

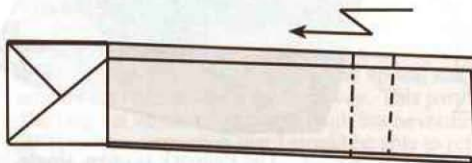

8. Pleat top layer only (no landmarks).

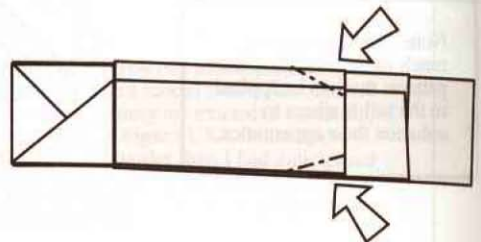

9. Inside reverse fold the corners.



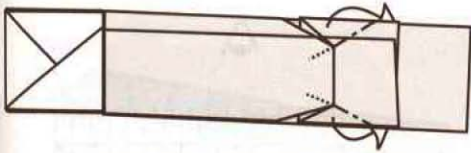

10. Mountain fold corners behind.

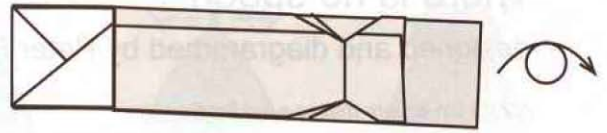

11. The tail is done. Turn over.

[www.japaoburajirujin.blogspot.com](http://www.japaoburajirujin.blogspot.com)

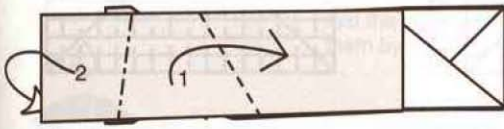

12. Fold to taste, to create upper and bottom fins.

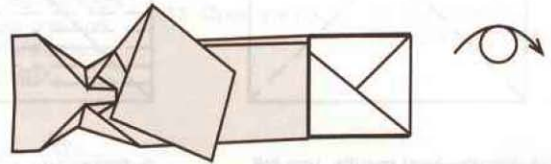

To make it look like this.  
Turn over.

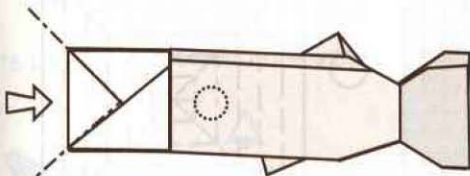

14. Gently push in the mouth - to make it 3-D. It helps if you place your finger inside.

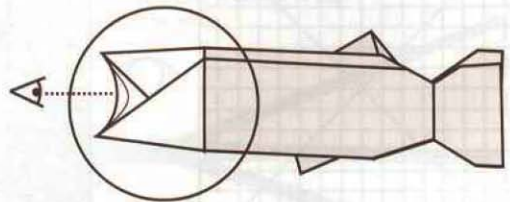

15. Views from the side and from the front.

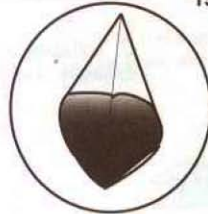

Here's a little song I wrote;  
ou might want to sing it  
note-for-note...

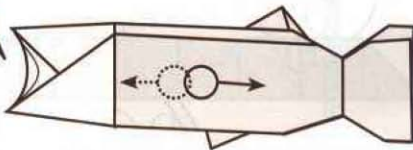

16. Place your thumb in the front, and your finger in the back, and slide in opposite directions...

Don't worry,  
Be happy!

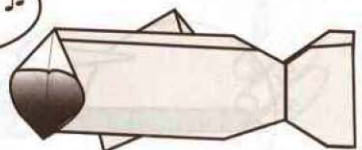

17. To make the fish sing!

Visit [WWW.GILADORIGAMI.COM](http://WWW.GILADORIGAMI.COM) for more!

# "There is no spoon"

[www.japaoburajirujin.blogspot.com](http://www.japaoburajirujin.blogspot.com)

designed and diagrammed by Peter Farina

A 21.3 cm square makes a ~ 17 cm spoon.

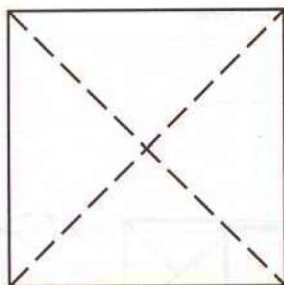

1. For the best results, use foil paper. Start with the color side down. Fold diagonals.

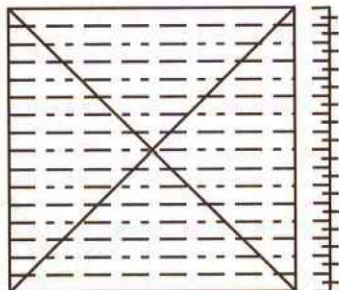

2. Divide into 1/16ths horizontally.

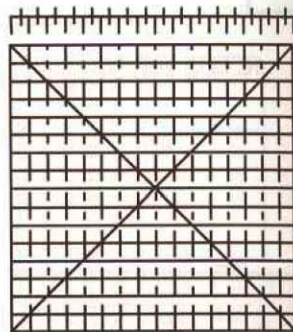

3. Divide into 1/16ths vertically.

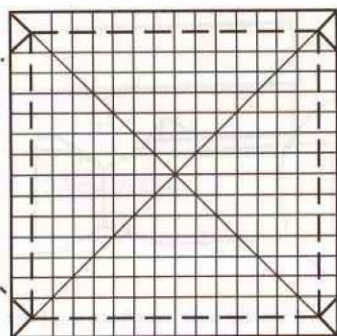

4. Collapse on existing creases. Turn over.

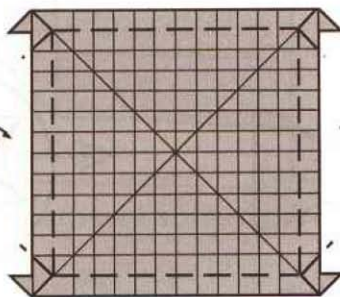

5. Collapse on existing creases. Turn over.

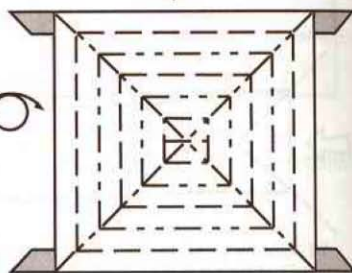

6. Repeat steps 4-5 three times.

4-5 (X 3)

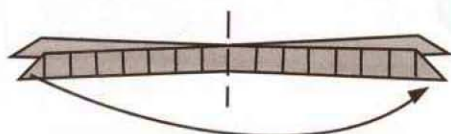

7. Swing one flap over.

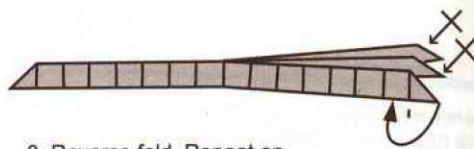

8. Reverse fold. Repeat on the two flaps behind.

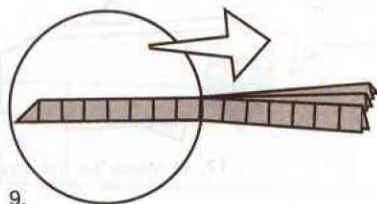

9.

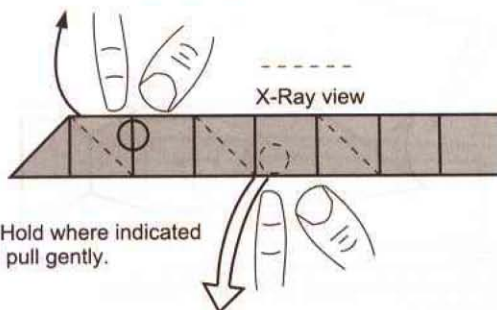

10. Hold where indicated and pull gently.

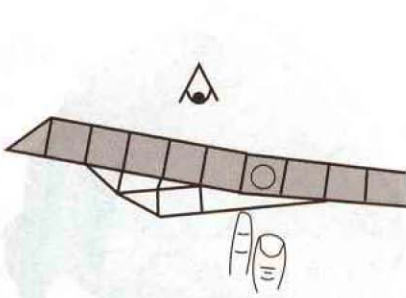

11. Pinch where indicated.



12. Round the spoon. There are two flaps in the center. Spread the larger one and fold the smaller one to the side. Flatten them by pressing with your thumb.

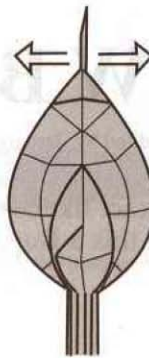

13. Open the tip.

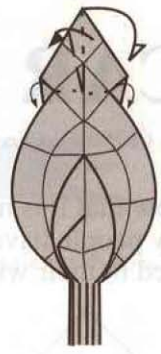

14. Fold the tip down as indicated.

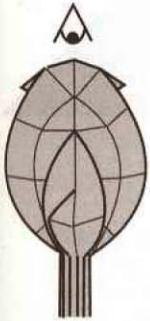

15. Like this.

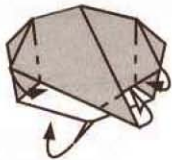

16. Reverse fold the corners. Tuck the tip under. Flatten the bottom of the spoon.

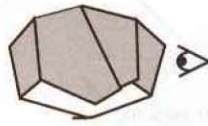

17. Like this.

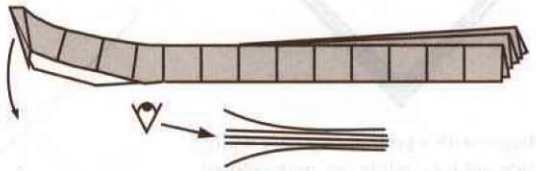

18. Bend the spoon down incorporating a crimp in the center layers.

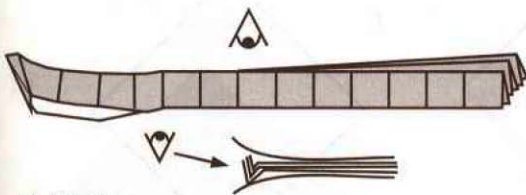

19. Like this.

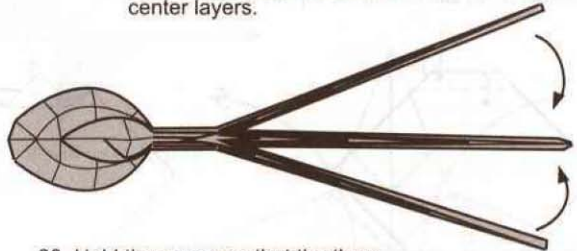

20. Hold the spoon so that the three handle flaps are pressed together.

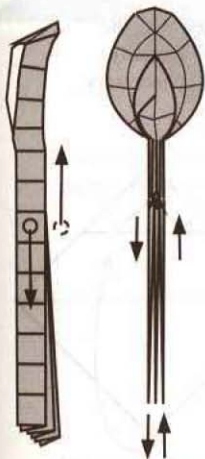

21. Simultaneously slide one handle flap down with your thumb and the opposite flap up with your index finger...



22. ...to make the spoon bend.

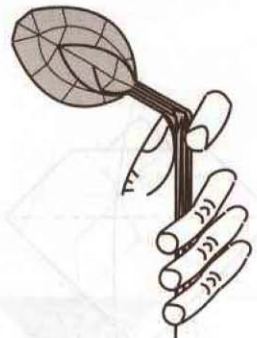
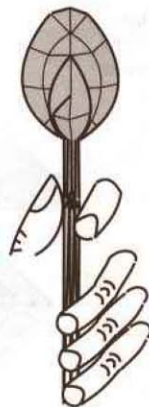

"Do not try and bend the spoon. That's impossible. Instead, only try to realize the truth . . . There is no spoon . . . Then you'll see that it is not the spoon that bends. It is only yourself."

- The Matrix

# CAR (VW BUG)

By: Charles Esseltine (2001) Edited by: Jeremy Shafer (2002)

I know that it is not an exact likeness. But so many people have called this a Bug, that I have bowed to their will.

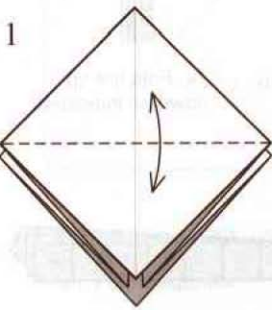
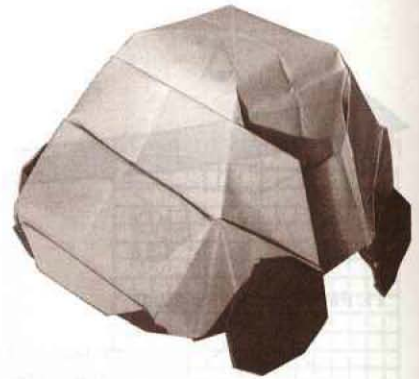

Begin with a preliminary base white side out for a white car, with colored wheels. I think foil is best for this model. But it can be done from any material. Fold and unfold the top layer.

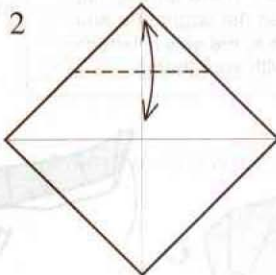

Fold the top to meet the center. Then unfold.

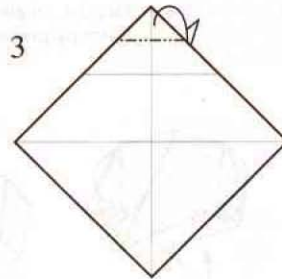

Fold the top point behind to the nearest crease.

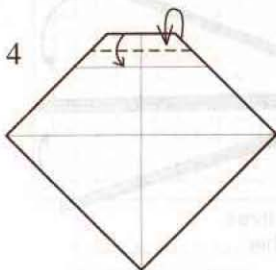

Fold down the new edge. This brings the top point back to the front.

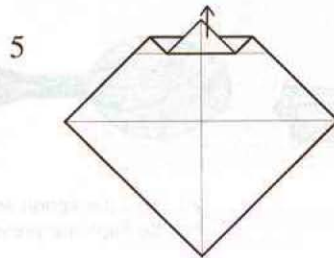

Unfold the layers.

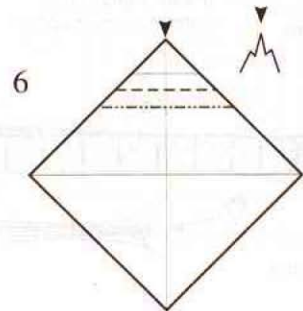

Pleat sink the center, with the center pointing up. Partially opening the model is necessary.

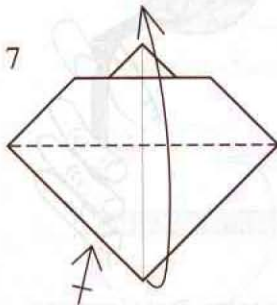

Fold up the front flap. Repeat behind.

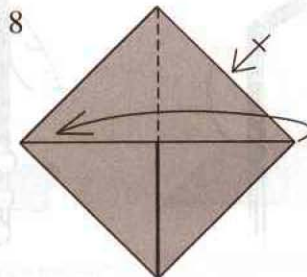

Open up the side, and refold the model so that the white side is on the outside.

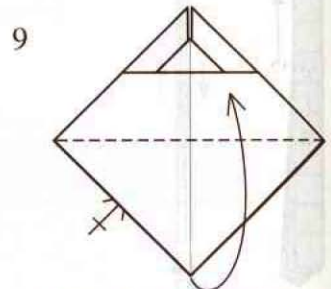

Fold up the remaining sides.

10a

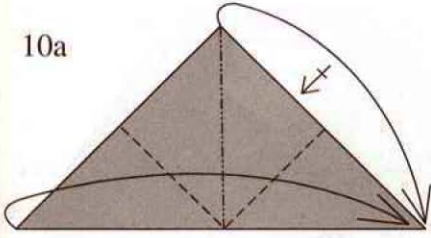

On the front layer, fold the top point to the right corner. Then fold the left point to the right corner.

10b



This is how the bottom will look like when it's done.

11

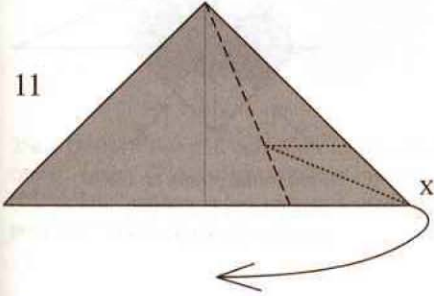

Fold the top 3 layers to the centerline. This will pull up one layer from point X. Fold it down to meet the bottom line.

12

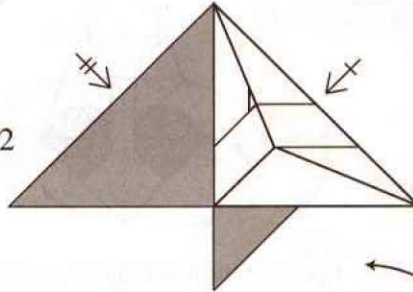

This is how it will look. Repeat on the other three sides.

14

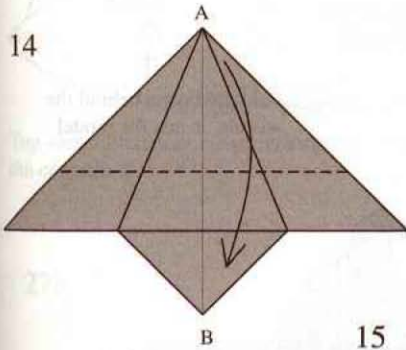

Fold the first layer down from point A to point B.

13

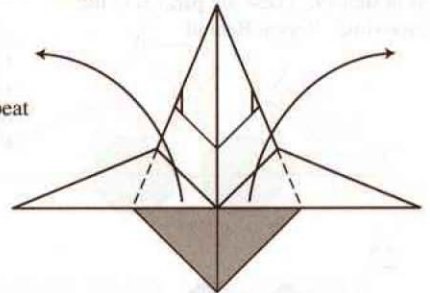

Open out the two middle sections without unfolding the ends.

15

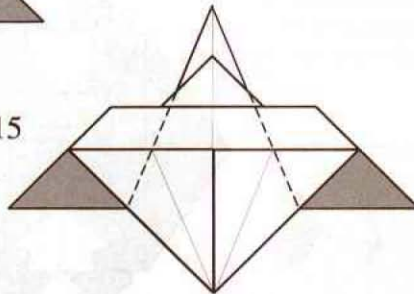

Fold the sections back along the existing lines.

16

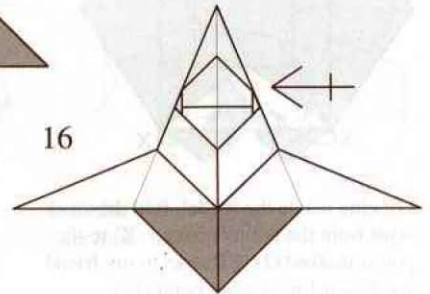

Repeat steps 13-15 on the back.

[www.japaoburajirujin.blogspot.com](http://www.japaoburajirujin.blogspot.com)

17

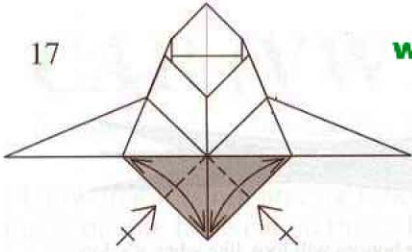

Fold and unfold the bottom flaps on both sides.

18

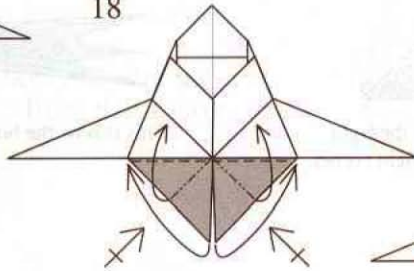

Squash fold the bottom sections. Repeat behind.

19

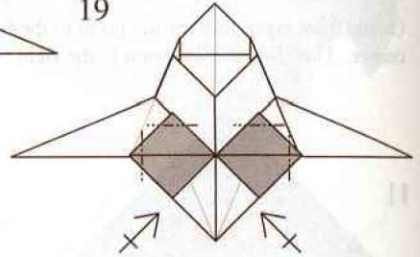

Fold in the points on the outside and top of the wheels. Repeat behind.

20

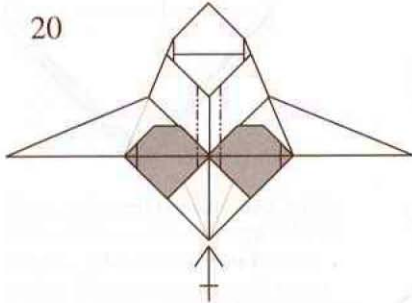

Fold the edges inward the same distance as in step 19. These are parallel to the centerline. Repeat Behind.

21

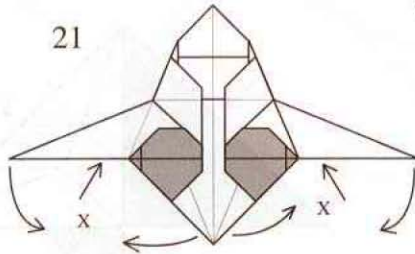

Open the bottom and form the roof. At point (X) open the layers and push upward on the interior layer to form the hood and trunk. Pull down the left and right points.

22

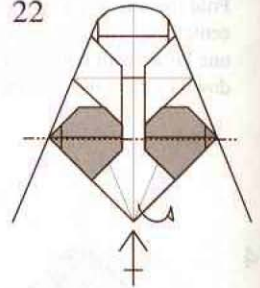

Fold the layers behind the wheels, inside the model.

23

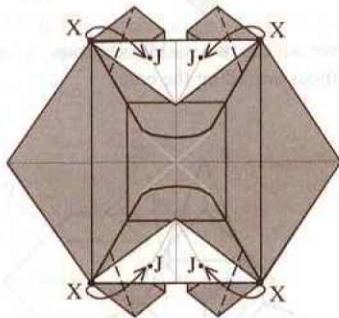

Looking inside the model, fold the inner layer from the points marked (X) to the points marked (J). [Thanks to my friend Joe Power for locating point (J).]

24

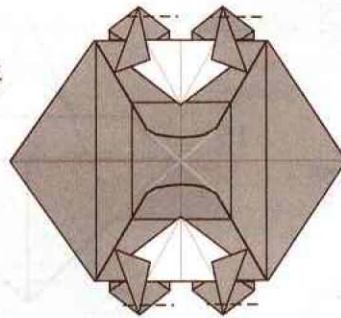

Fold in the bottoms of the wheels. Note: The larger the model, the more you can round the wheels.

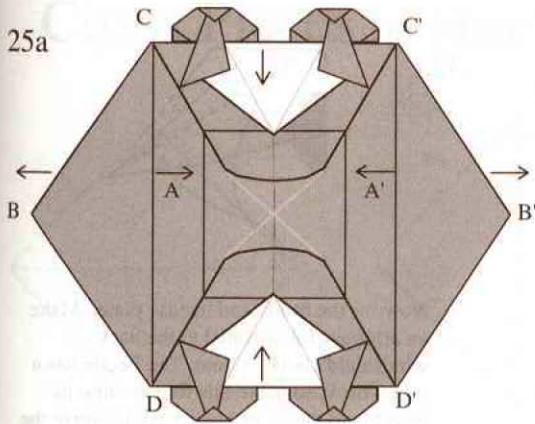

25a.) On each side pull only layer (A & A') in towards the center. Line CD of layer (A) will arc inward, and the sides (CC' & DD') will move towards each other. The outer points (B & B') will move apart.

25b.) The model should look like this.

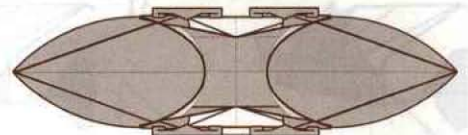

Bottom View

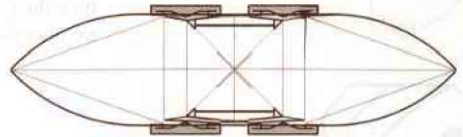

Top View

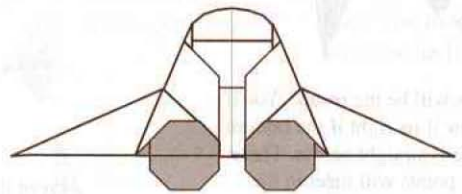

Side View

Now for the tough part! Choosing which side will be the front!

26

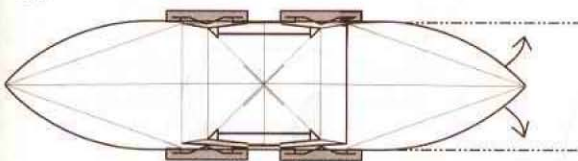

Top view. Flatten one end, making the creases parallel to the centerline.

27a

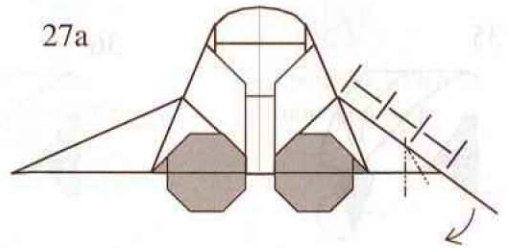

This looks harder than it is. About 2/3 of the way down the edge of the hood, make a soft crease. Pinch the corners so that the front points straight down.

27b

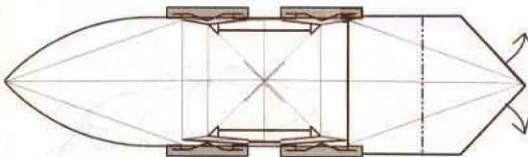

Same step, different view.

28

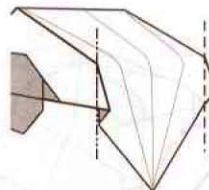

Fold the tips inward, so that they are flat against the front.

29

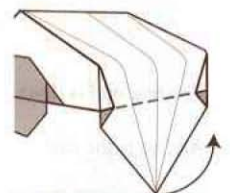

Fold the bottom up as far as it will go.

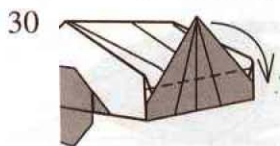

Now fold it down a little bit shy of the top of the hood.

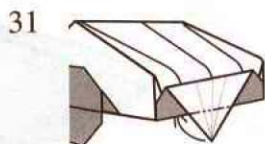

To finish the headlights, just tuck the remaining tip under the edge.

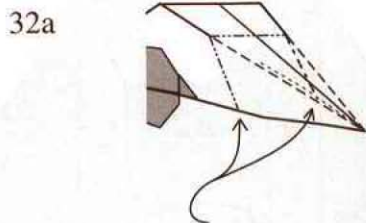

Now for the trunk, and license plate. Make an arbitrary fold parallel to the back windshield's edge. (Note: The Beetle has a round back, so make this fold as close as possible to the windshield.) And reverse the creases as indicated. A soft crease will form on each side of the trunk.

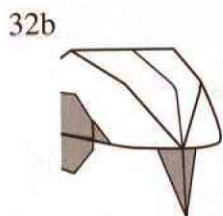

This will be the result. You'll know if its right if the bottom edge is straight across. These two points will meet in the middle of the back. If you want a wider European style plate, leave a gap between the points.

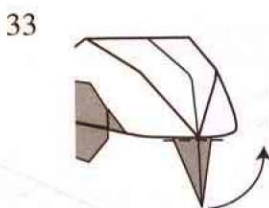

From the bottom edge, fold the point up as far as it will go.

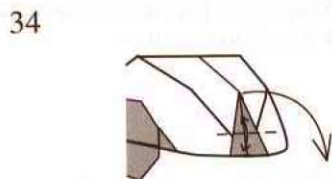

Using the edges as a guide, fold, and unfold a line where they meet. Bring the point back down.

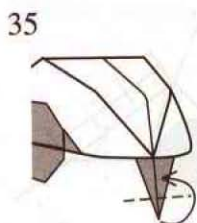

Fold the tip to the marker fold.

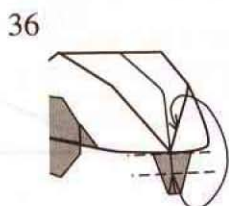

Tuck the flap inside the edges to lock the trunk.

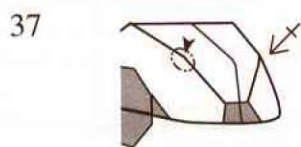

Now that the trunk is formed, we can add the taillights. Dimple sink the points to taste.

O.K. We've got the trunk locked. Now We've got to figure out how to unlock the doors!

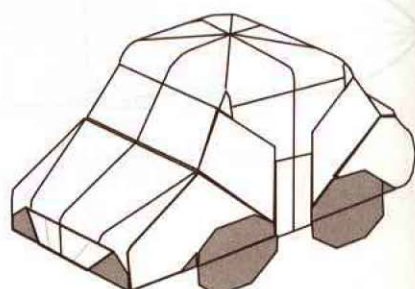
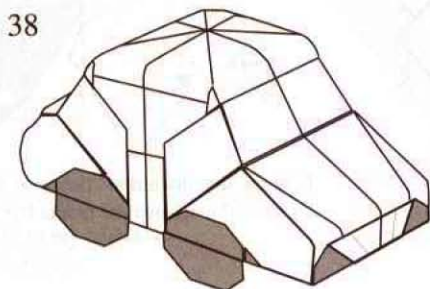

The rear end is done.

And so is the car!

Drive Safely!



# Chess Pieces by Marc Kirschenbaum ©1996

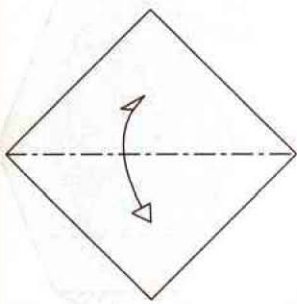

1. Precrease with a mountain fold.

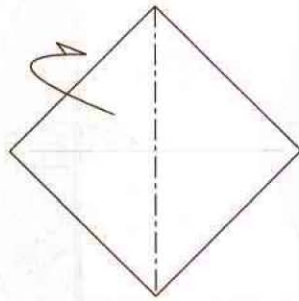

2. Mountain fold in half.

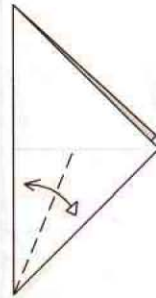

3. Precrease the lower portion.

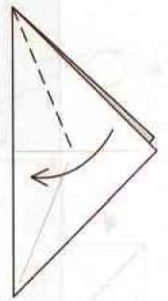

4. Valley fold part way. The model will not lie flat.

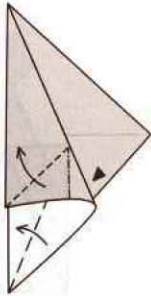

5. Squash fold to flatten.



6. Repeat steps 3-5 behind.

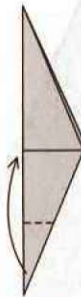

7. Valley to the center.



8. Precrease with a mountain fold.

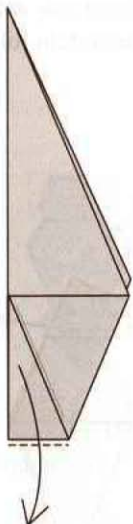

9. Unfold.

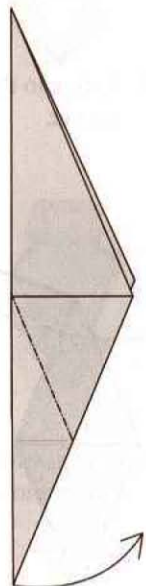

10. Reverse fold.

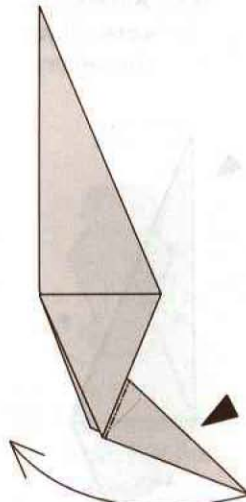

11. Reverse fold again.

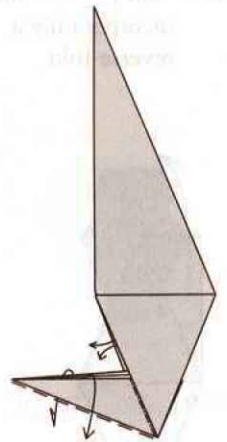

12. Pull out a single layer at each side.

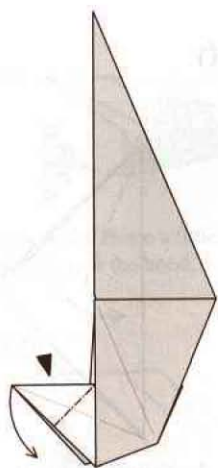

13. Reverse fold.

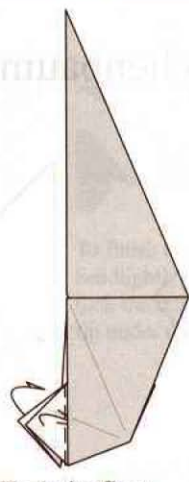

14. Tuck the flaps under the outer layers.

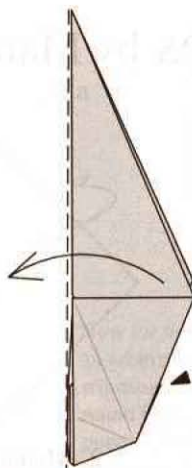

15. Open out, allowing the center flap to squash flat.

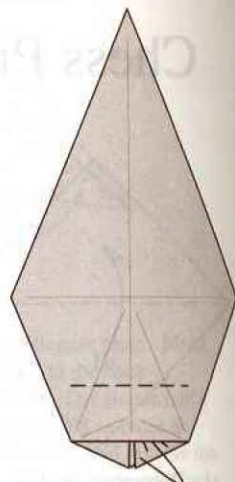

16. Valley into the pocket.

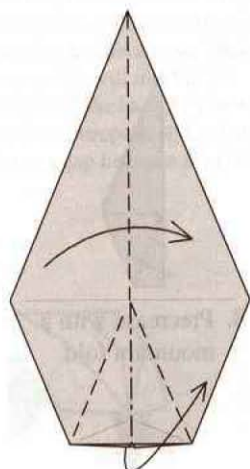

17. Valley over, while incorporating a reverse fold.



18. Reverse the center layer through.

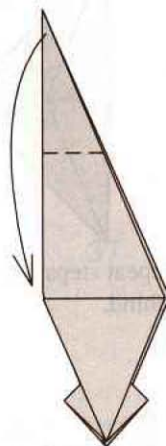

19. Valley to the corner.



20. Precrease with a mountain fold.

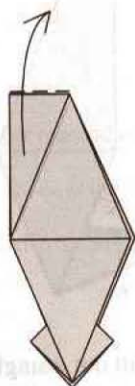

21. Unfold.

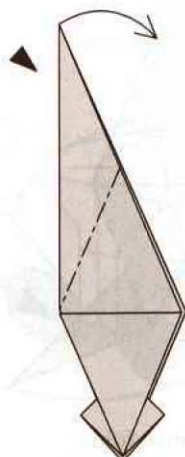

22. Reverse fold.

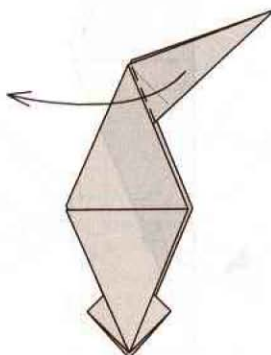

23. Valley over.

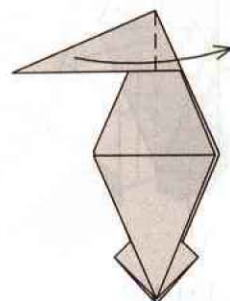

24. Valley again.

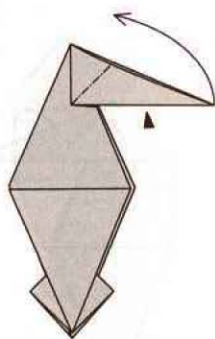

25. Squash fold.

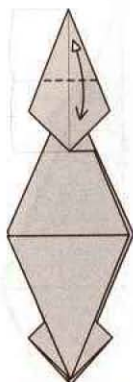

26. Precrease and turn over.

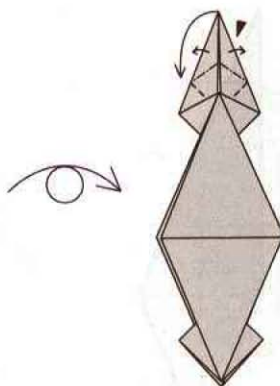

27. Squash fold, so as to make the top look the same on both sides.

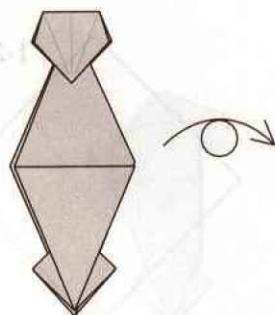

28. Turn over.

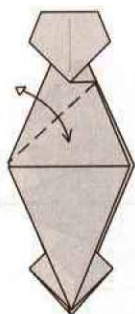

29. Precrease.

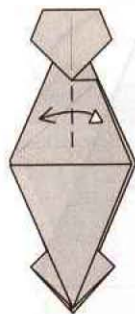

30. Precrease the top section in half.



31. Reverse fold in and out. Note that the valley fold goes through the intersection of creases.

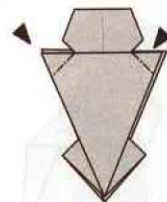

32. Reverse fold the thick corner at the left, and one corner at the right.

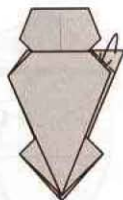

33. Tuck the flap into the pocket.

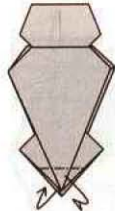

34. Mountain fold the corners in.

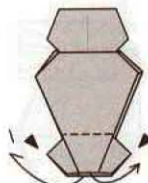

35. Open out the base. You can either crease sharply or leave it rounded.



36. Completed Pawn.

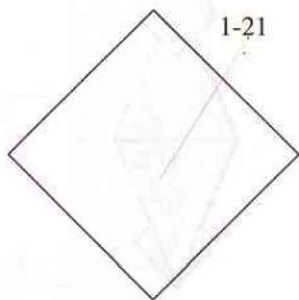

37. Begin with a same sized square for the castle. Repeat steps 1-21.

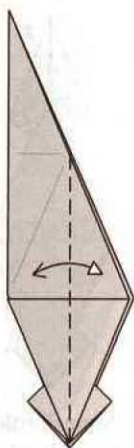

38. Precrease lightly. Repeat behind.

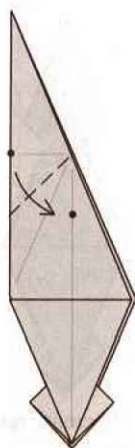

39. Valley, such that the creases meet.

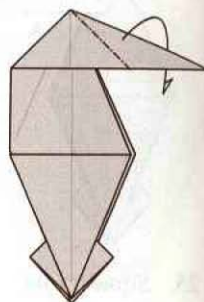

40. Mountain fold.

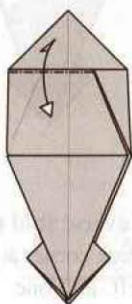

41. Precrease with a mountain fold.

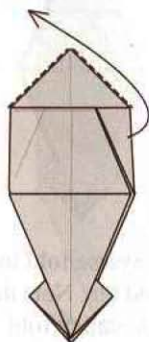

42. Open out the flap.

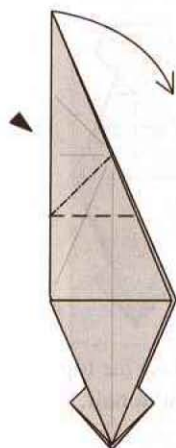

43. Squash fold.

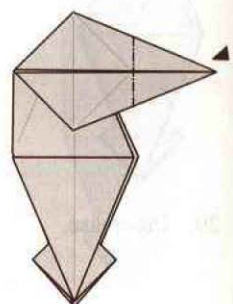

44. Sink the tip.

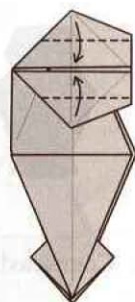

45. Valley the corners to the center.

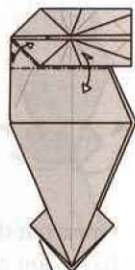

46. Precrease with mountain folds.

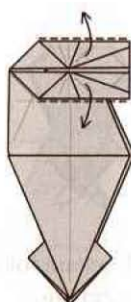

47. Open out.

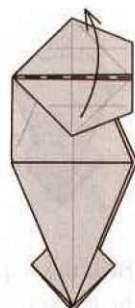

48. Swing up.

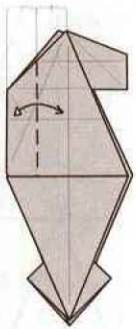

49. Precrease.

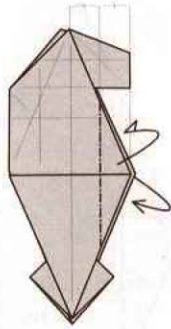

50. Mountain fold the sides in halfway.

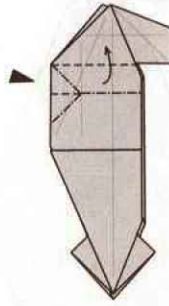

51. Crimp upwards, while pushing in the side.

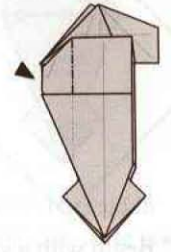

52. Sink halfway. Part of the sink is hidden.

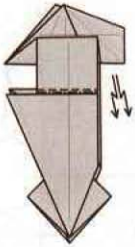

53. Form a very tiny crimp.

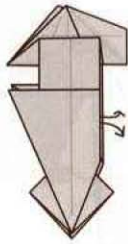

54. Pull out a layer from each side, allowing the upper edge to taper.

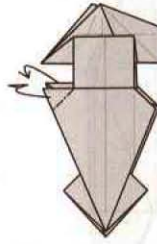

55. Mountain fold the two corner to match the right side.

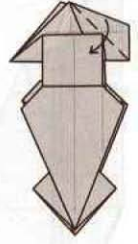

56. Valley over at each side to lock.

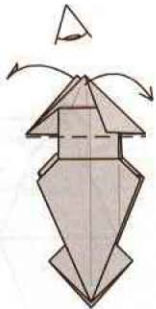

57. Open out the sides at a angle.

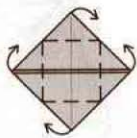

58. View from above. Valley each corner up at a 90° angle.

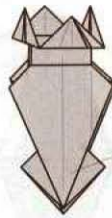

59. Repeat steps 34-35.



60. Completed Castle.

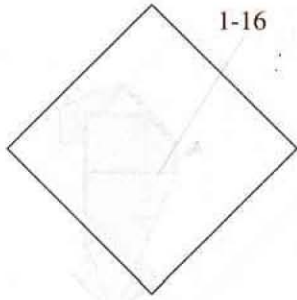

61. Begin with a same sized square for the knight. Repeat steps 1-16.

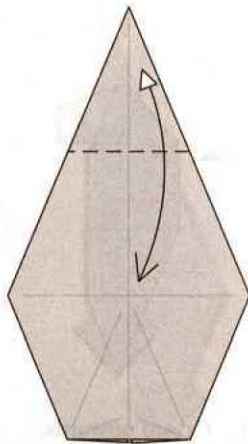

62. Precrease.

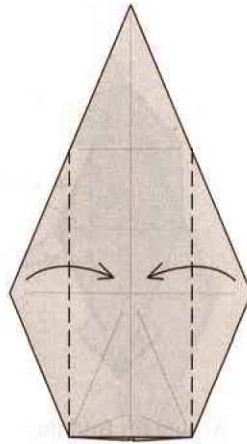

63. Valley to the center. Do not crease sharply.

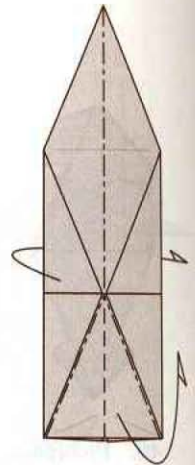

64. Mountain fold in half, while incorporating a reverse fold.

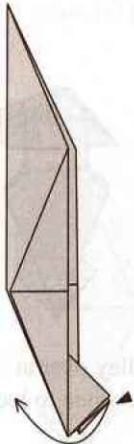

65. Reverse the center layer through.

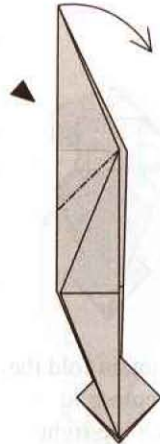

66. Reverse fold.

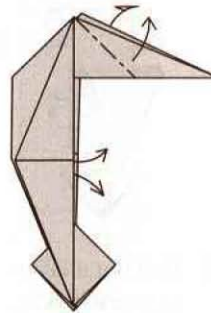

67. Pull out a layer from each side. Do not completely flatten.

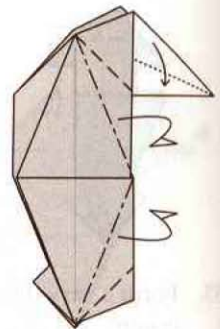

68. Swivel in all of the sides, and flatten.

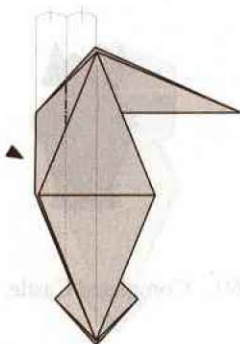

69. Closed sink the center flap halfway.

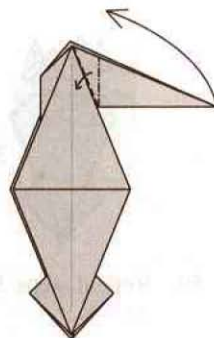

70. Crimp upwards.

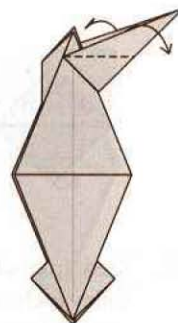

71. Outside reverse fold.

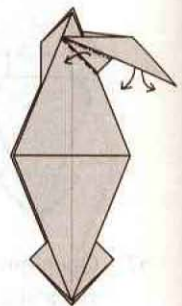

72. Pull out a single layer from each side as far as possible.

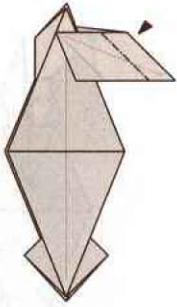

73. Closed reverse fold.

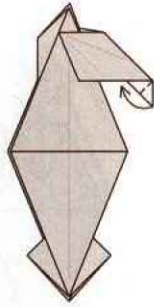

74. Outside reverse fold.

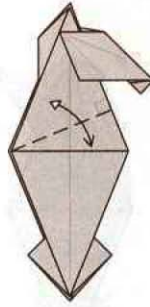

75. Precrease.

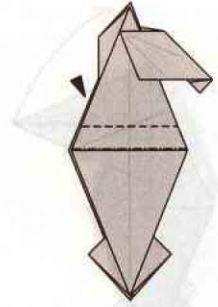

76. Reverse fold in and out. Note that the valley fold goes through the intersection of creases.

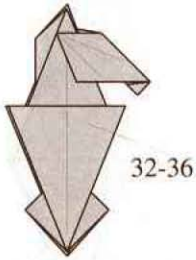

77. Repeat steps 32-36.

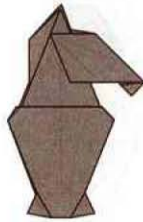

78. Completed Knight.

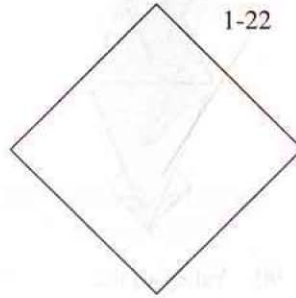

79. Begin with a same sized square for the bishop. Repeat steps 1-22.

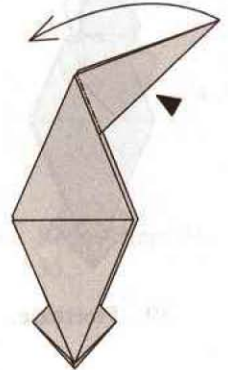

80. Reverse fold.

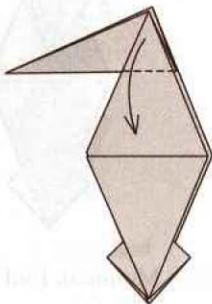

81. Open out.

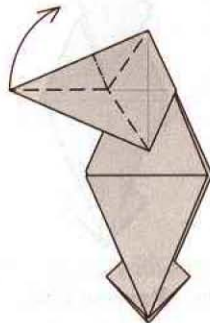

82. Rabbit ear.

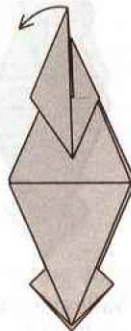

83. Undo the rabbit-ear.

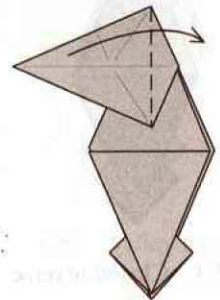

84. Swing over.

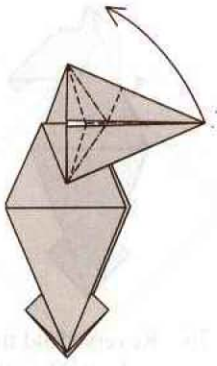

85. Redo the rabbit-ear, while adding additional folds.

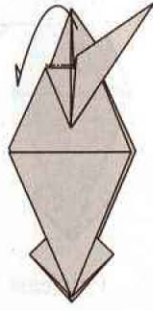

86. Swing back.

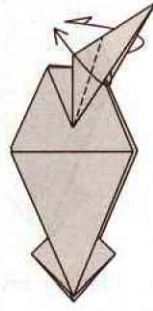

87. Outside reverse fold.

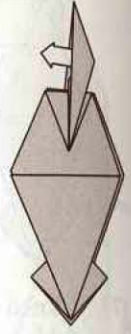

88. Pull out a single layer at each side.

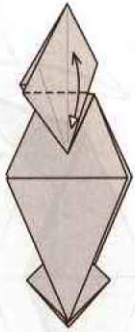

89. Precrease.

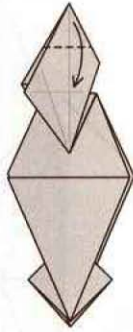

90. Valley to the intersection of creases.

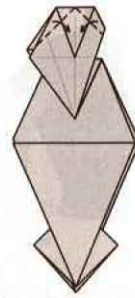

91. Valley to the center.

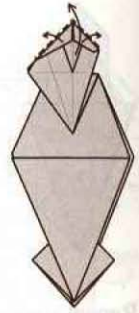

92. Unfold.

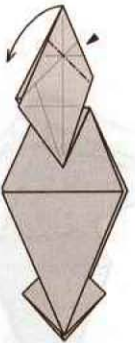

93. Closed reverse fold.

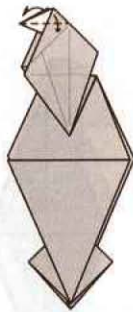

94. Valley down at each side.

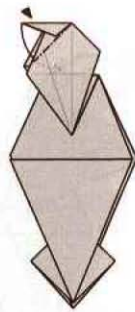

95. Reverse fold.

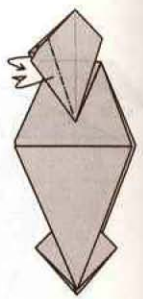

96. Mountain fold at each side.



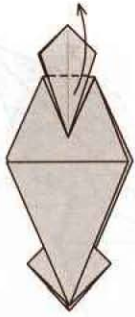

97. Valley up.

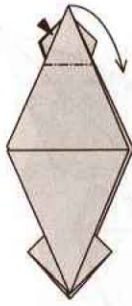

98. Reverse fold.

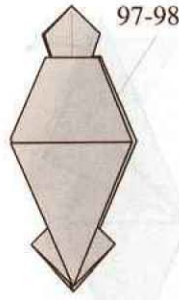

99. Repeat steps 97-98 behind.

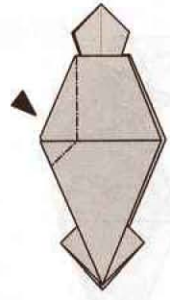

100. Invert the corner. The model will not lie flat.

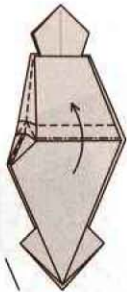

101. Crimp both sides to flatten.

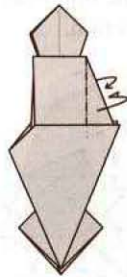

102. Swivel in both sides.

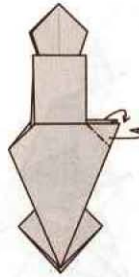

103. Mountain fold the two corners.

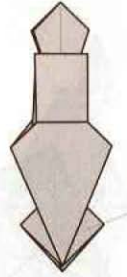

104. Repeat steps 34-35.



105. Completed Bishop.

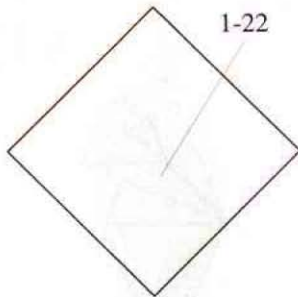

106. Begin with a same sized square for the queen.

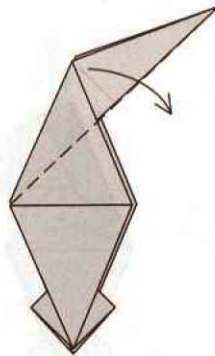

107. Swing down lightly.

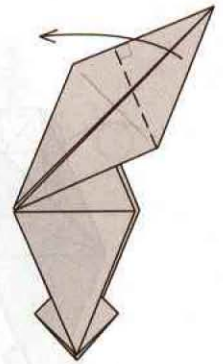

108. Valley over.

[www.japaoburajirujin.blogspot.com](http://www.japaoburajirujin.blogspot.com)

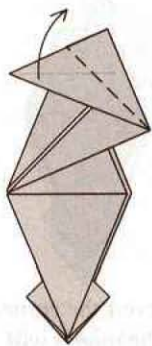

109. Valley up.

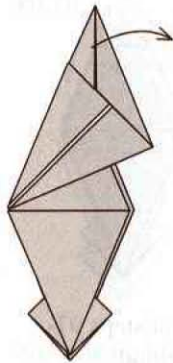

110. Unfold the pleat.

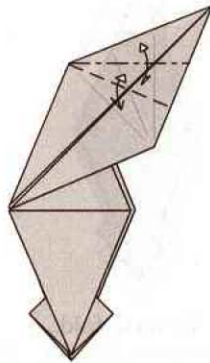

111. Repeat the precreases from steps 108 and 109 in the opposite direction.

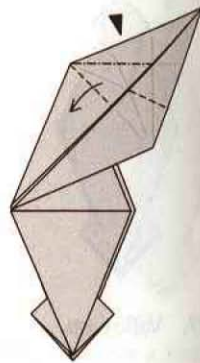

112. Squash fold.

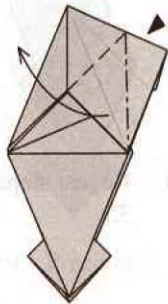

113. Squash again.

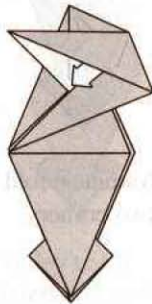

114. Pull out a single layer.

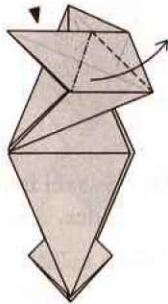

115. Squash fold.

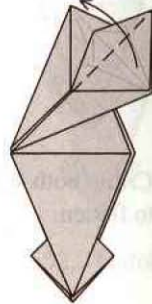

116. Valley up.

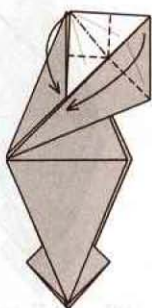

117. Swing the flap down, while incorporating a reverse fold.

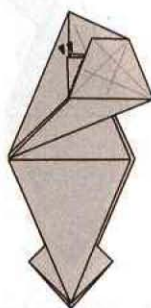

118. Reverse fold twice.

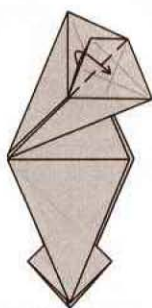

119. Swing the center flap over.



120. Flip the cluster of flaps upwards.

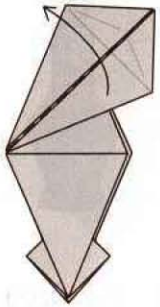

121. Swing up.

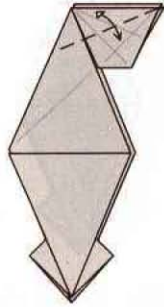

122. Precrease.

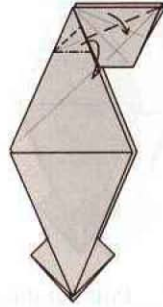

123. Swivel fold.

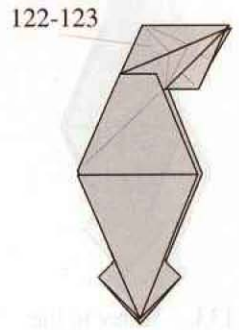

124. Repeat steps 122-123 behind.

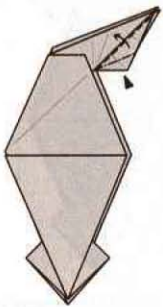

125. Spread squash.

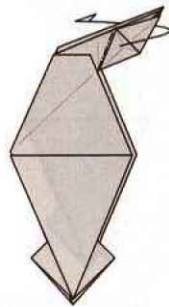

126. Mountain fold.

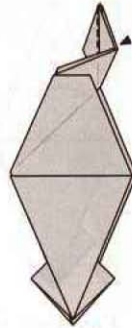

127. Reverse one layer through.

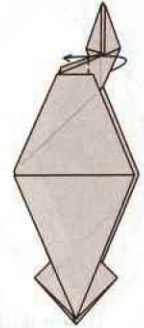

128. Valley so as to align along the center.

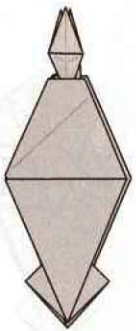

129. Turn over.

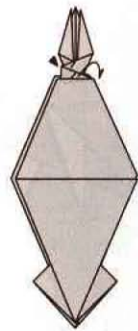

130. Swivel fold the double layer.

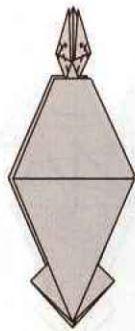

131. Valley the top layers to the center.

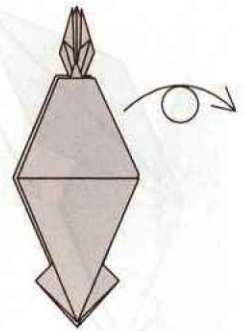

132. Turn over.

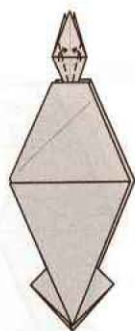

133. Valley to the center.

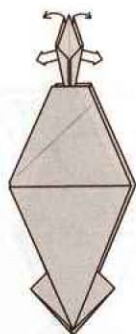

134. Pull out the side flaps.

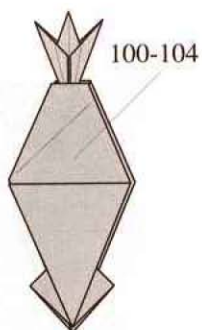

135. Repeat steps 100-104.



136. Completed Queen.

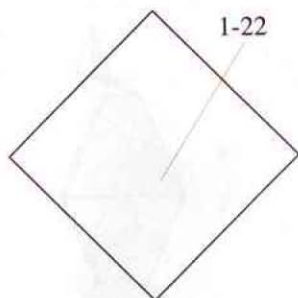

137. Begin with a same sized square for the king. Repeat steps 1-22.

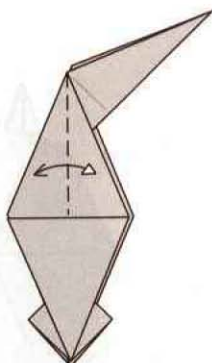

138. Precrease in half lightly.

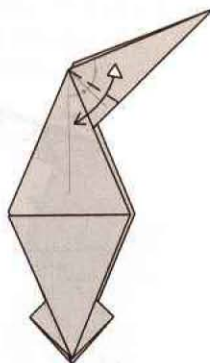

138. Bring the flap along the center and unfold.

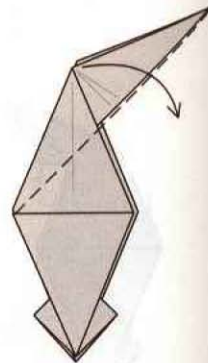

139. Lightly open out the flap.

[www.japaoburajirujin.blogspot.com](http://www.japaoburajirujin.blogspot.com)

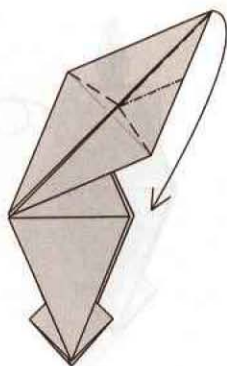

140. Rabbit ear using the existing creases.

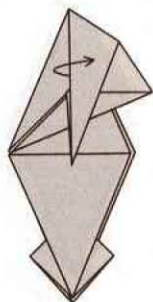

141. Wrap around a single layer.

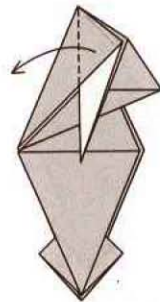

142. Swing over.

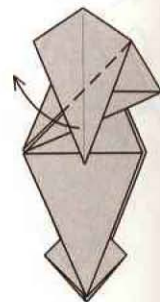

143. Valley up lightly.

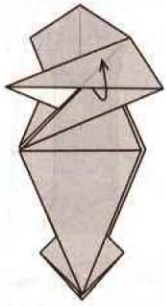

144. Wrap around a single layer.

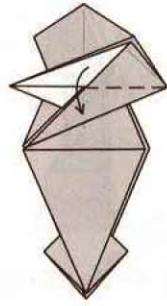

145. Swing down.

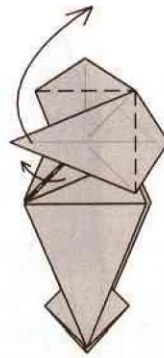

146. Pull the flap up, while collapsing.

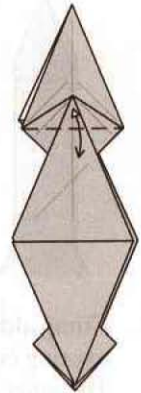

147. Precrease.

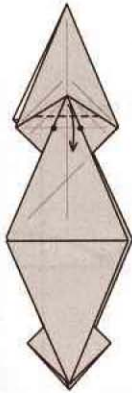

148. Valley allowing the edges to meet the indicated intersections.

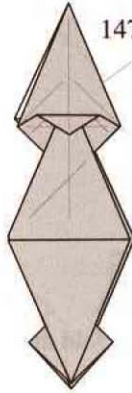

149. Repeat steps 147-148 behind.

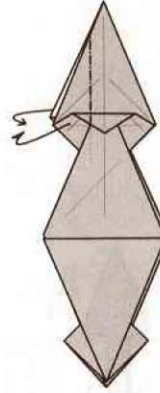

150. Mountain fold the sides.

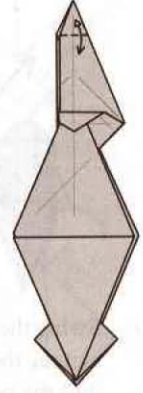

151. Precrease.

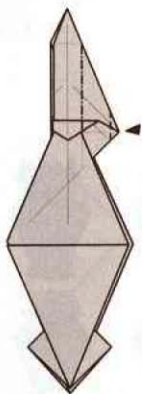

152. Closed sink the corner in and out.

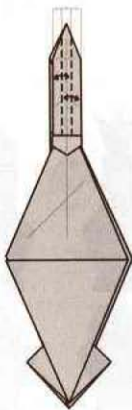

153. Precrease into thirds.



154. Precrease.

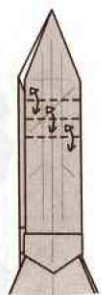

155. Precrease, using the intersection of creases as guides.

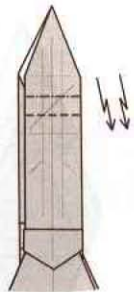

156. Crimp along the existing creases. The inner layers will not be symmetrical.



157. Valley over, pulling some paper from inside the crimp.

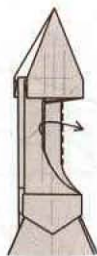

158. Swing through.

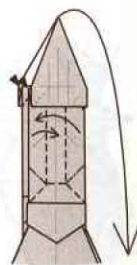

159. Swivel the sides inwards, allowing two reverse folds to form at the right. The flap will swing down.

[www.japaoburajirujin.blogspot.com](http://www.japaoburajirujin.blogspot.com)

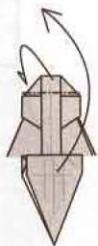

160. Swing the flap up, tucking the excess into the pocket behind.

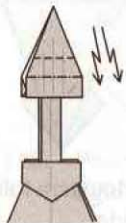

161. Crimp the tip.

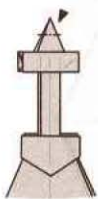

162. Reverse fold the tip.

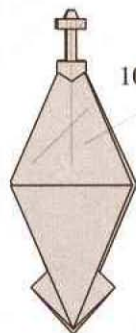

163. Repeat steps 100-104.



164. Completed King.

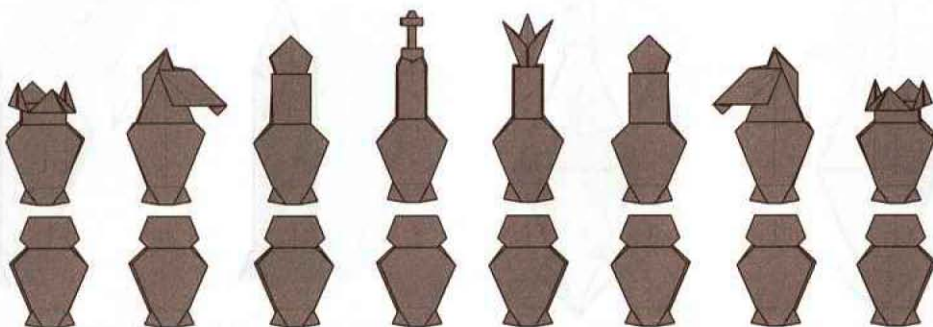

165. Completed Chess Pieces.  
©1996 Marc Kirschenbaum

# SIRENA

POR: Willyman Reed Cardona A  
COLOMBIA

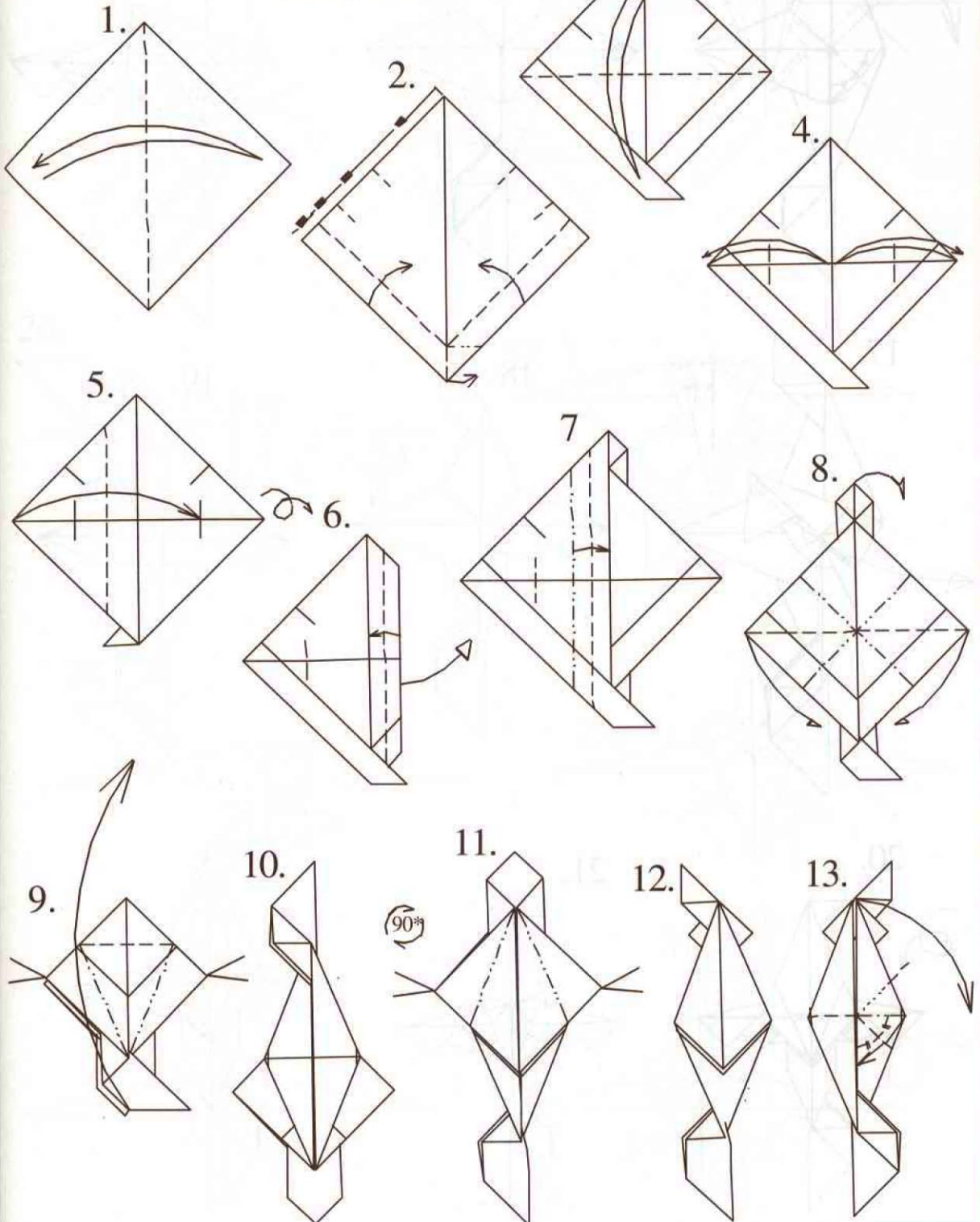

14.

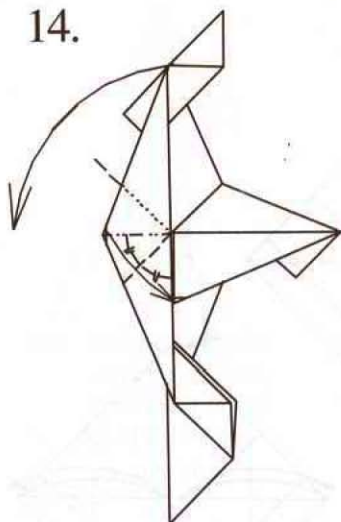

15.

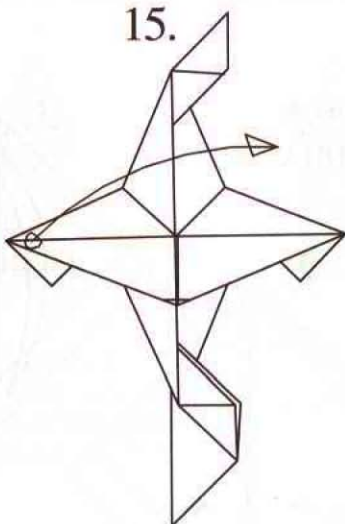

16.

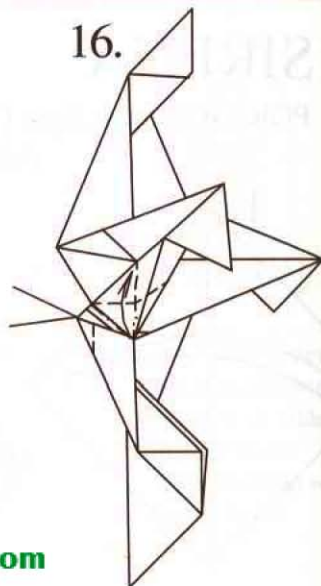

[www.japaoburajirujin.blogspot.com](http://www.japaoburajirujin.blogspot.com)

17.

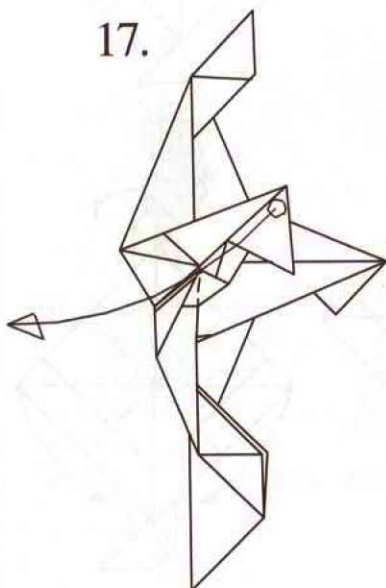

18.

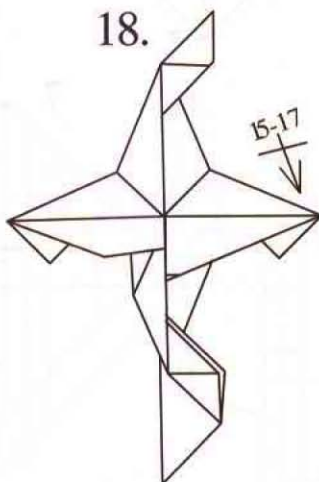

19.

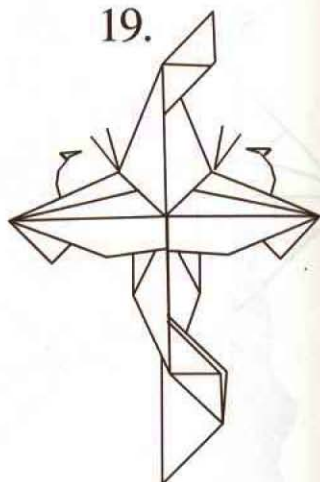

20.

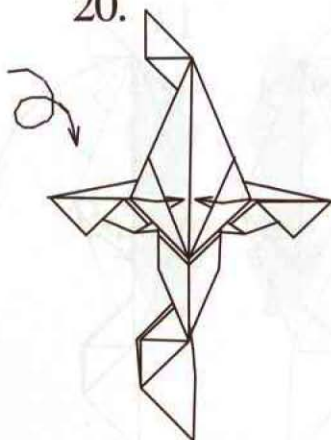

21.

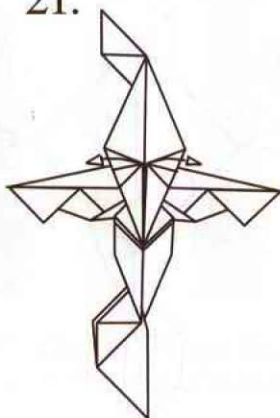

22.

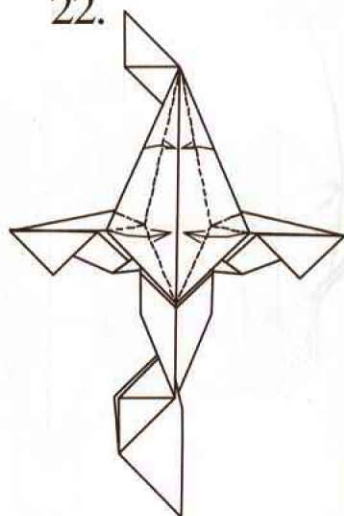



23.

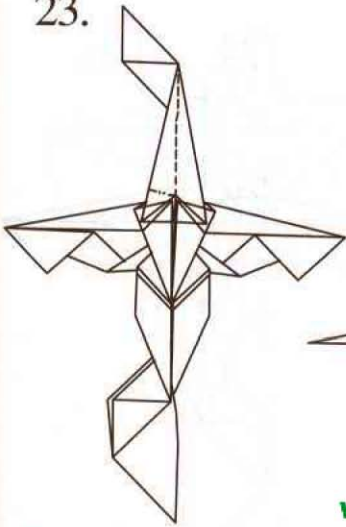

24.

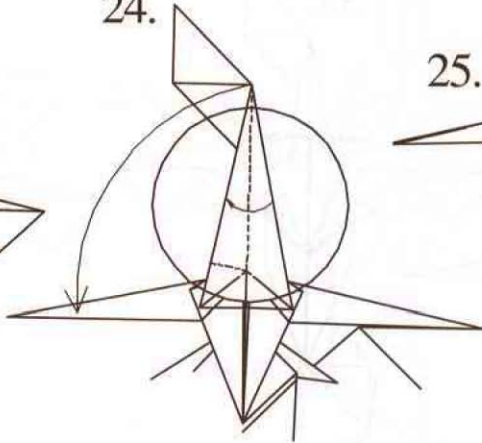

25.

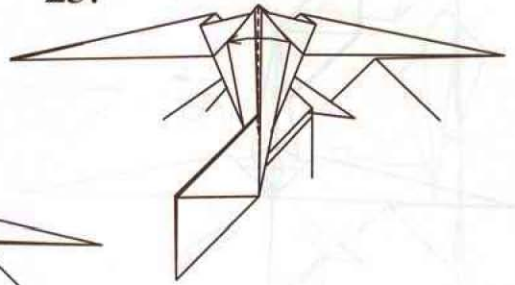

[www.japaoburajirujin.blogspot.com](http://www.japaoburajirujin.blogspot.com)

26.

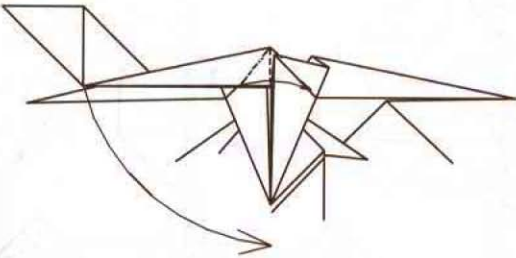

27.

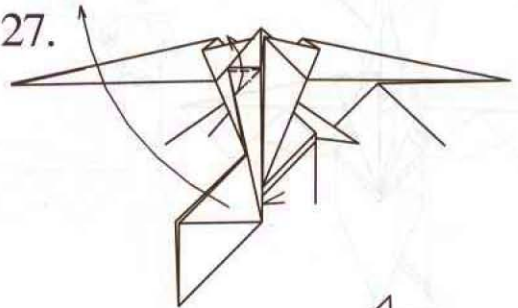

28.

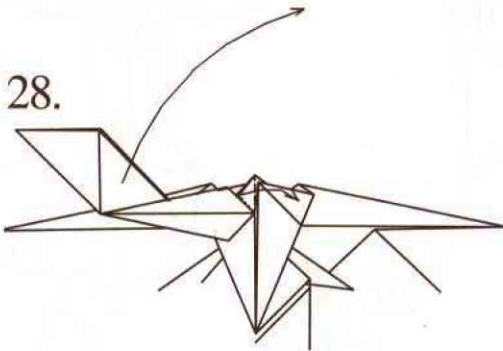

29.

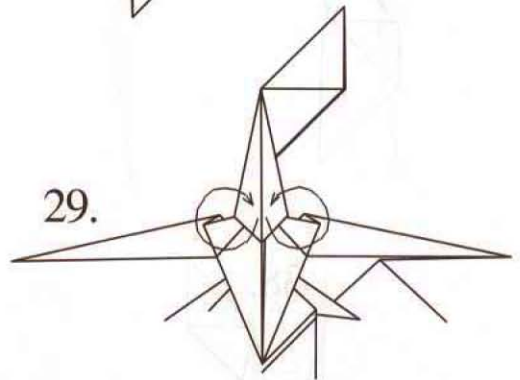

30.

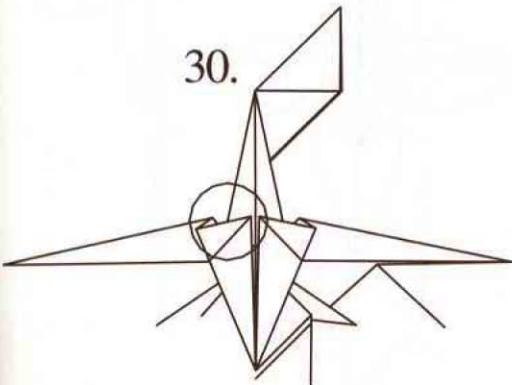

31.

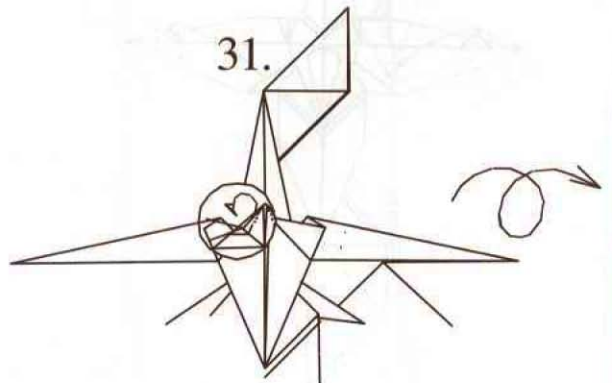

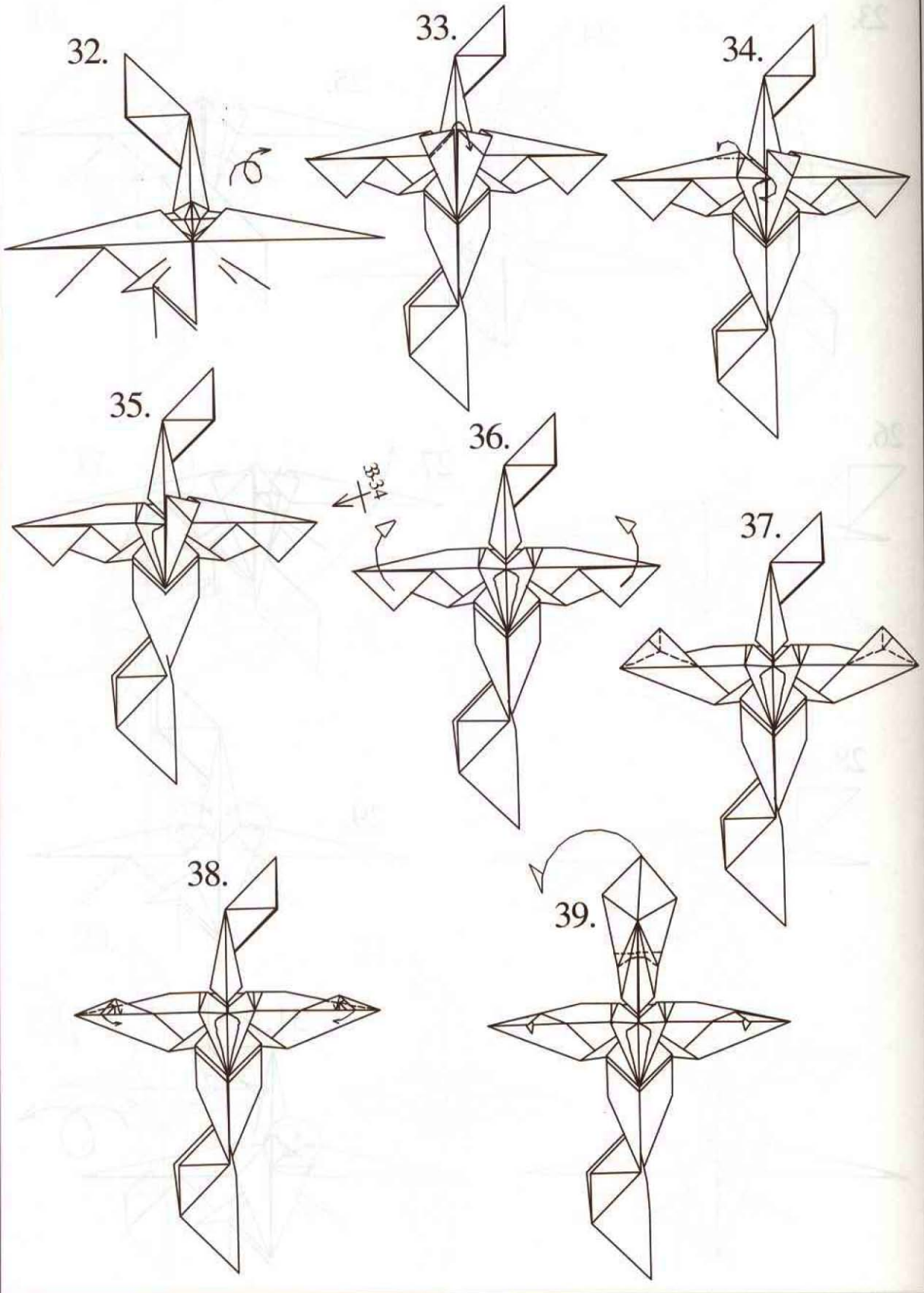

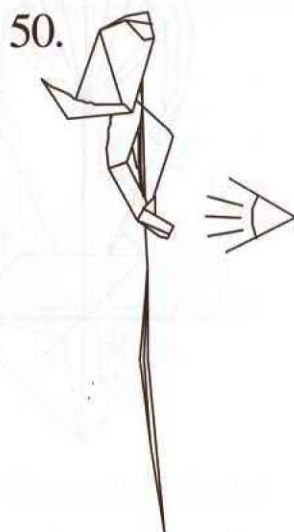
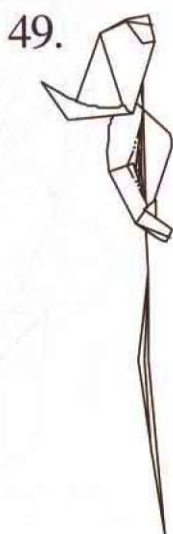
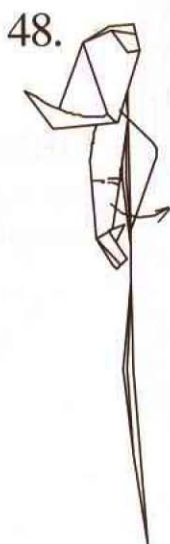
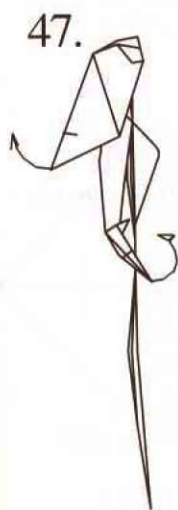
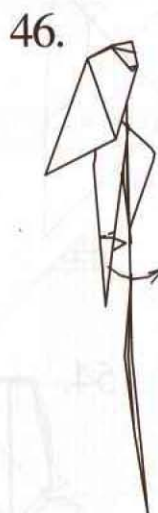
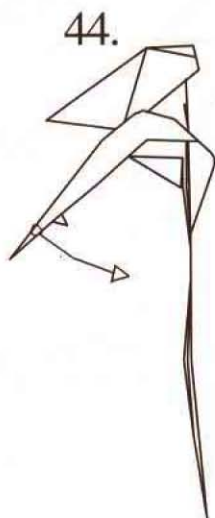
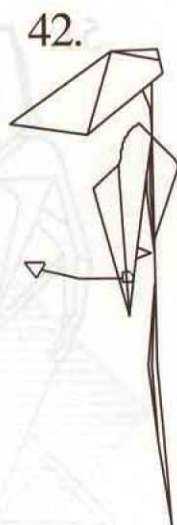
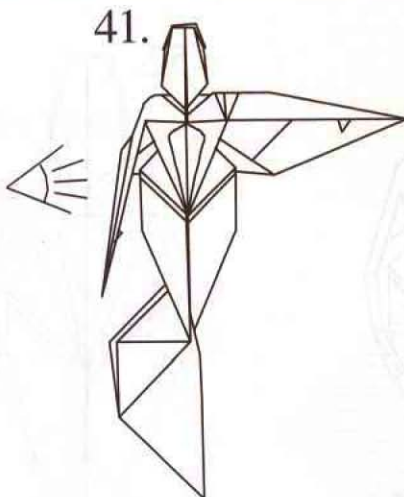
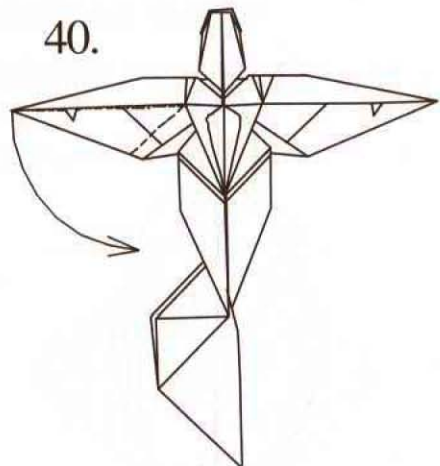

51.

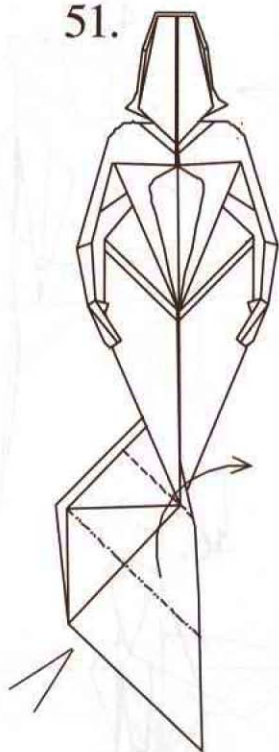

52.

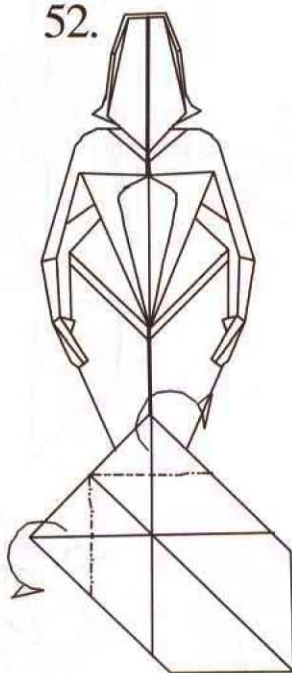

53.

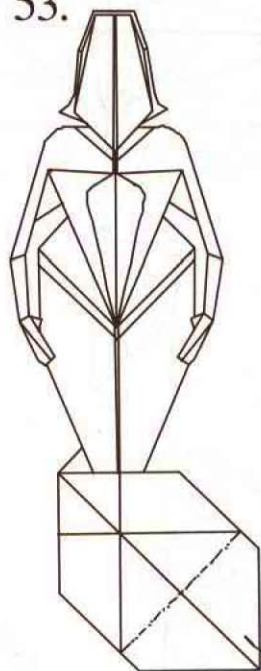

54.

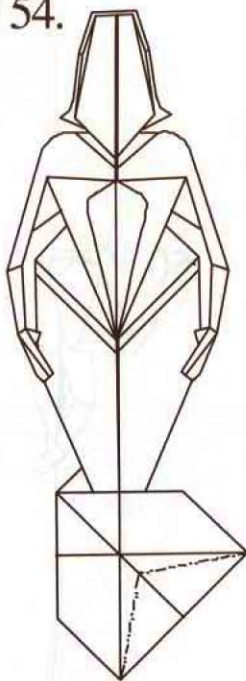

55.

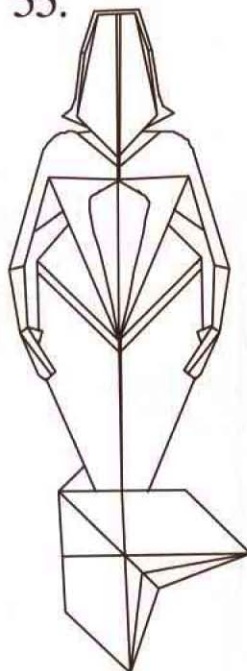

## SIRENA

POR: Willyman Reed Cardona A  
COLOMBIA

# Golden Snitch

designed and diagrammed by Peter Farina

A 12 cm square makes a golden snitch with a ~12.5 cm wingspan.

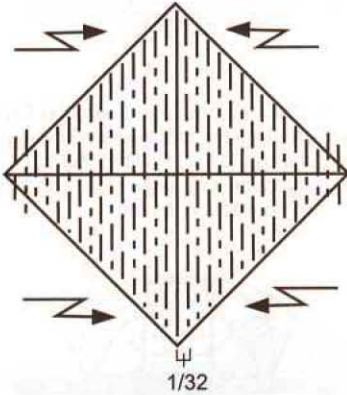

1. For best results, use gold foil. Divide into thirtyseconds (1/32) and pleat.

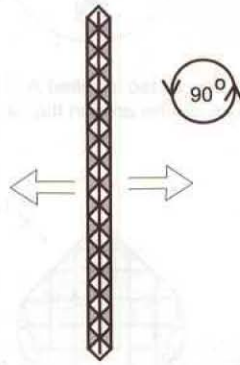

2. Unfold and turn the paper so the creases are horizontal.

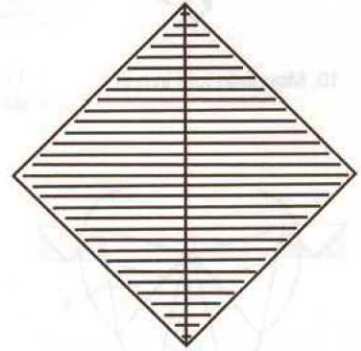

3. The next diagrams have some creases omitted to make them clearer.

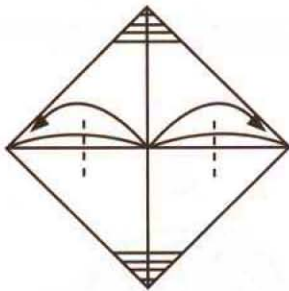

4. Fold the corners to the center and make a light crease. Unfold. Turn over.

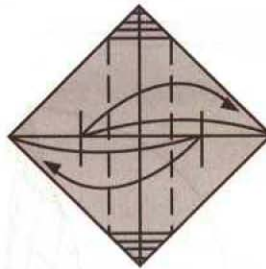

5. Fold the corner to the crease made in step 4 and unfold. Repeat on the other side.

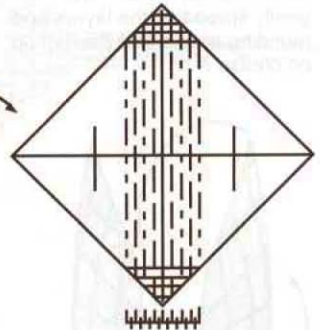

6. Divide the area between the creases made in step 5 into 8 equal sections.

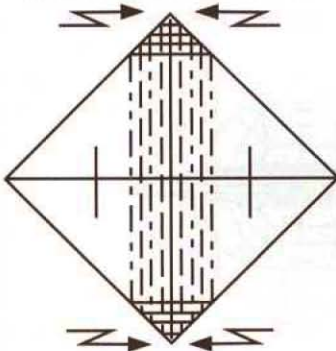

7. Pleat.

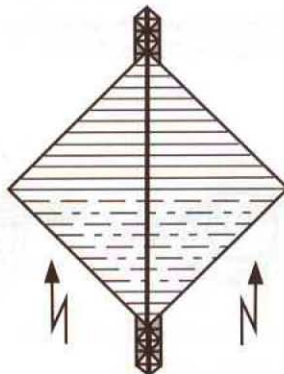

8. Pleat on existing creases.

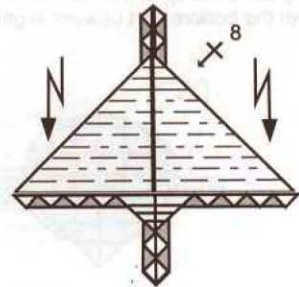

9. Repeat step 8 on the top half.

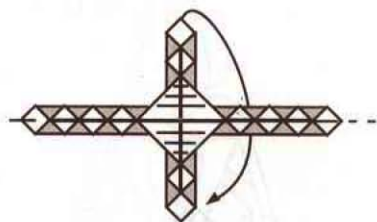

10. Mountain fold in half.

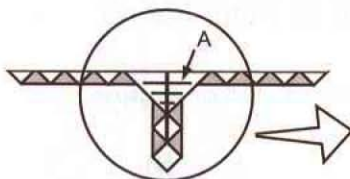

11. Note the crease labelled A. The next steps focus on the area in the circle.

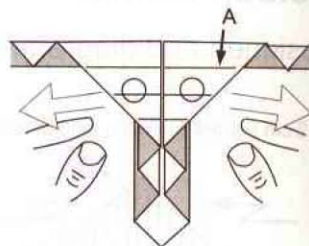

12. Grab the large triangular flaps. (Make sure that you are holding only the top layer.) Pull the flaps in opposite directions slowly and gently to spread the layers.

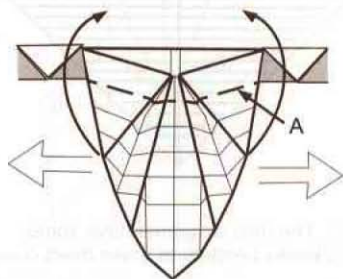

13. From this point on, the model will not lie flat. Keep gently spreading the layers and rounding as you fold the flap up on crease A.

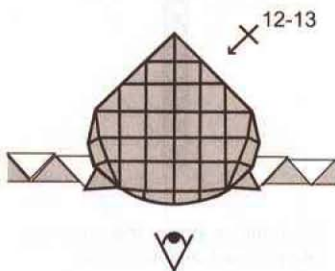

14. Repeat steps 12-13 on the other side.

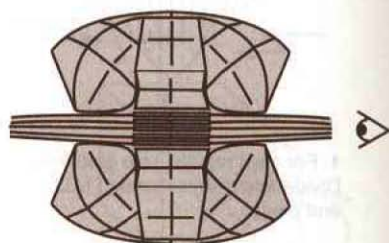

15. This a veiw from the back. The next diagram is a view from the side.

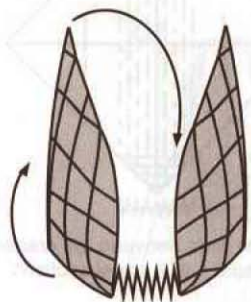

16. Gently bend the tip of the left flap down and swivel the bottom part upward slightly.

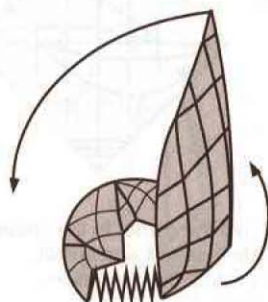

17. Repeat step 16, wrapping the right layer over the left.

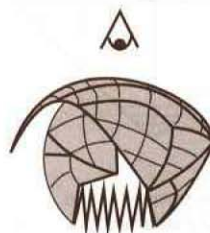

18. Like this. The next diagram is a view from the front.

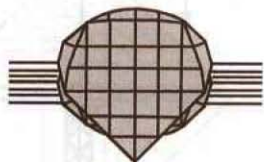

19. Turn over

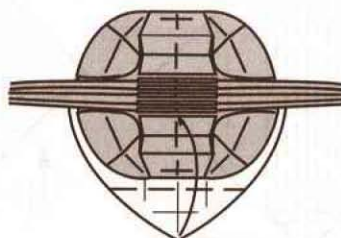

20. Fold the tab up.

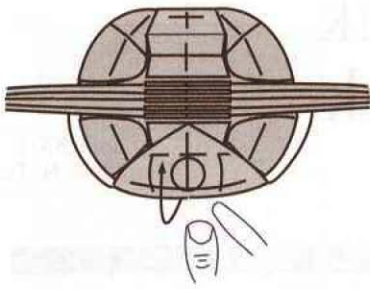

21. Grab the model where indicated, pinch and fold to keep the flap in place.

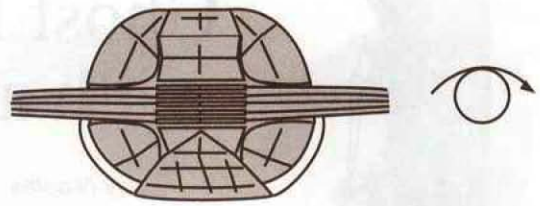

22. Turn model over.

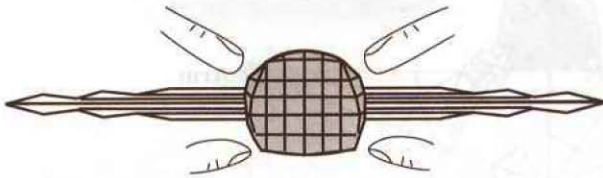

23. Pinch gently to shape the ball.

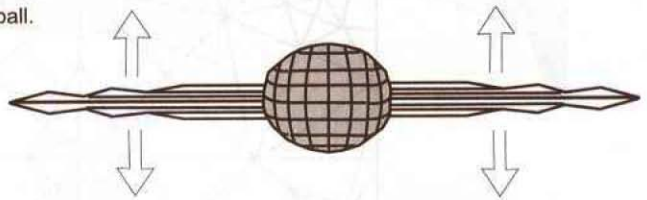

24. Spread the wings.

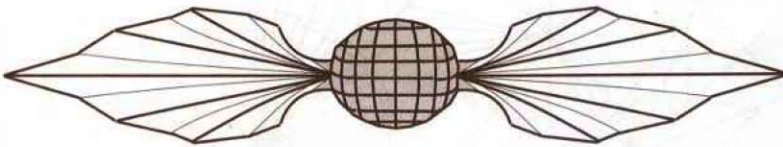

25. Shape wings to taste.

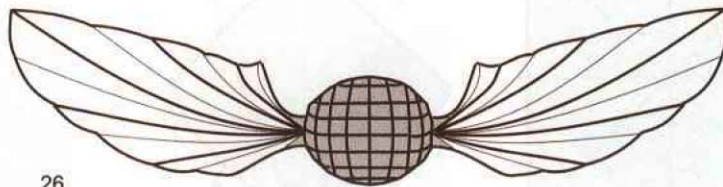

26.

Now pick up your wand and enunciate clearly:

Wingardium leviosa

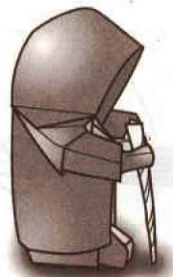

# Ghost Monk with a stick

By Nicolas TERRY

april 2003  
Diagram : N. Terry

**Dimension** : a square of 20 cm makes a monk of 7 x 4 cm.

Note the asymmetry  
of the Crease Pattern !

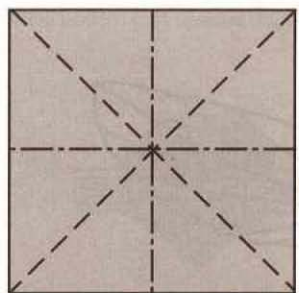
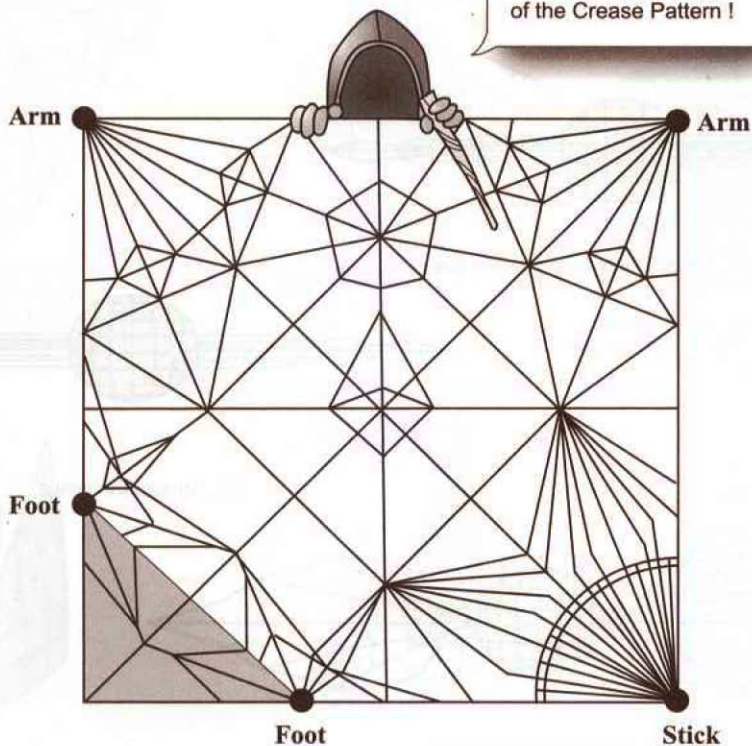

20 cm  
20 cm

1. Start with white side down.

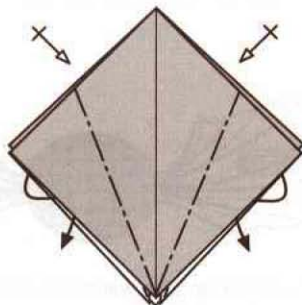

2. Four reverse  
folds.

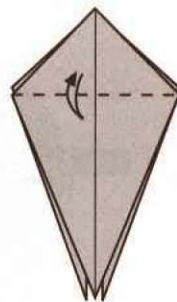

3. Bird Base. Fold and Unfold.  
Then, unfold until step 1.



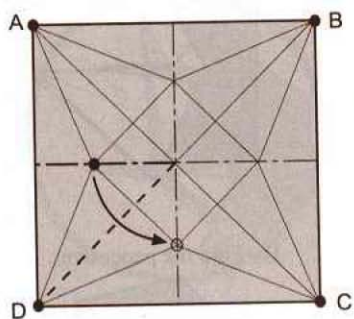

4. The model becomes 3D.  
The fold creates a pyramidal shape.

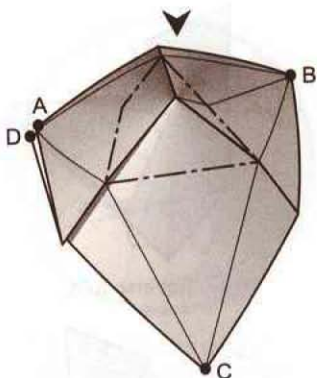

5. Sink the tip.

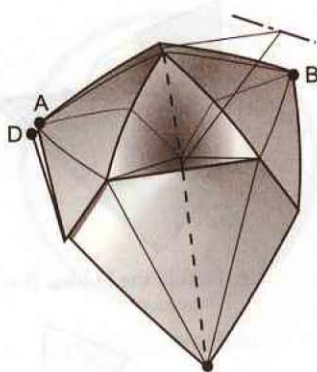

6. Fold in half.

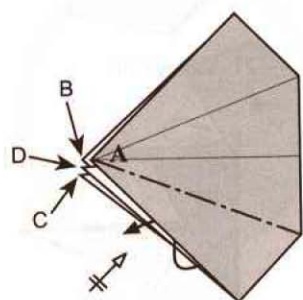

7. Three reverse folds.

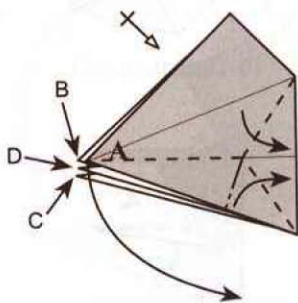

8. Rabbit ear on the flaps A & B.

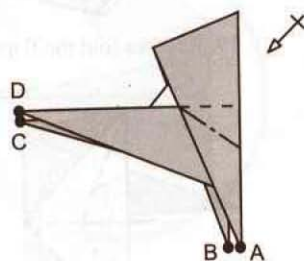

9. Squash Fold.  
Repeat behind.

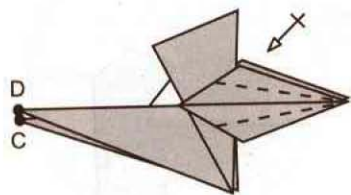

10. Fold and unfold.  
Repeat behind.

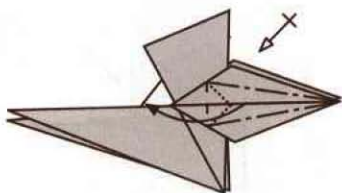

11. Petal-fold.  
Repeat behind.

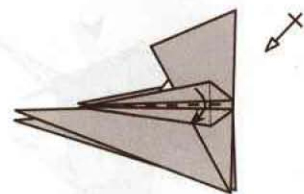

12. Valley fold.  
Repeat behind.

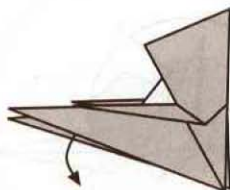

13. Pull the loose paper out.

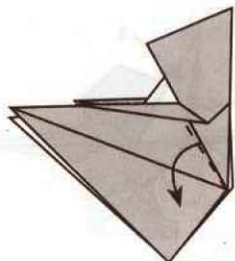

14. Unfold the hidden flap.

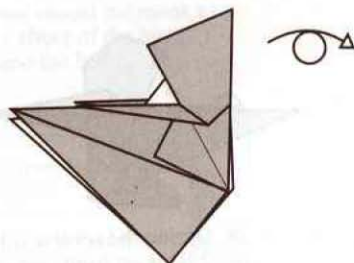

15. Turn the paper over.

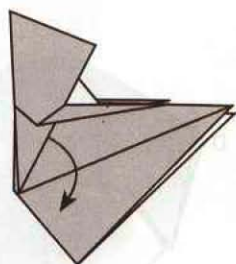

16. Unfold the hidden flap.

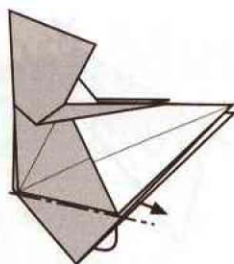

17. Reverse fold.

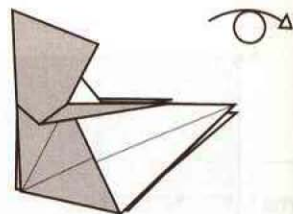

18. Turn the paper over.

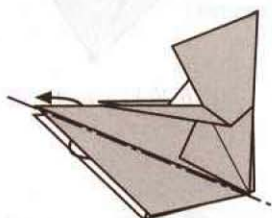

19. Reverse fold the flap.

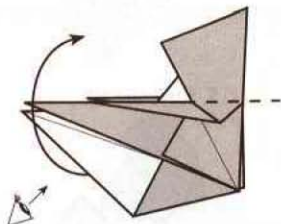

20. Open the model.

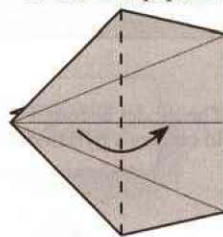

21. Valley fold.

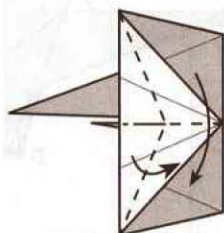

22. Fold the flap.  
Turn the paper over.

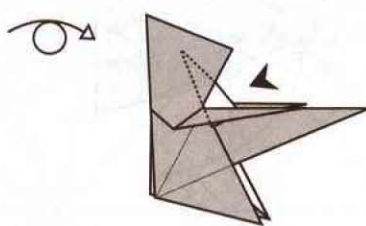

23. Sink the white flap  
inside the model.

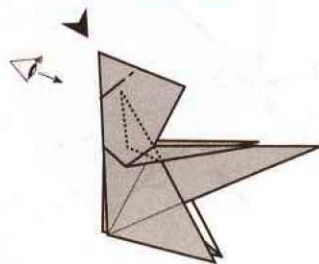

24. Sink the top of the head.  
See the next step.

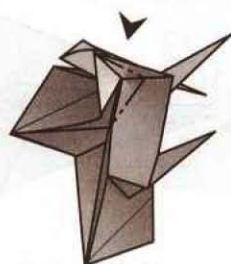

25. Work in progress.

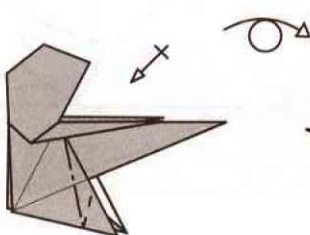

26. Crimp the feet.  
Turn the paper over.

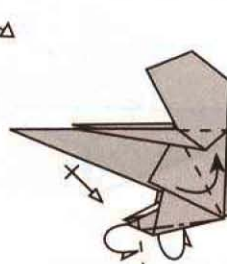

27. Fold the feet. Then open  
the left arm and valley  
fold the first flap.

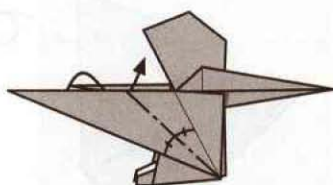

28. During the reverse fold,  
put 2 flaps on front (see the  
flaps a & b on the next step)  
and one behind (flap c).

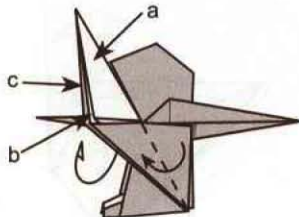

29. Insert the coloured flap  
behind the flap a.

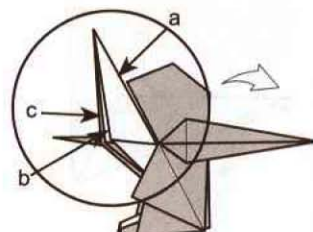

30. The flaps b & c will be  
now fold together as one flap.

[www.japaoburajirujin.blogspot.com](http://www.japaoburajirujin.blogspot.com)

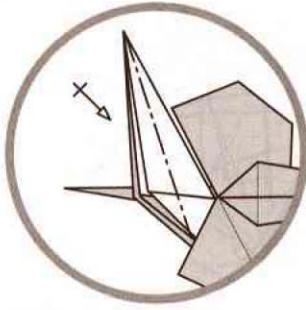

31. Mountain fold and repeat behind (Enlarged view).

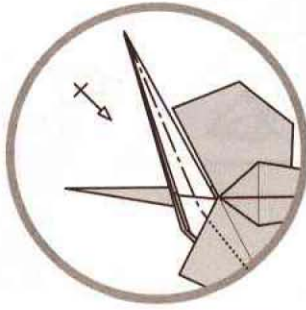

32. Continue to refine the stick from the top to the base. Repeat behind.

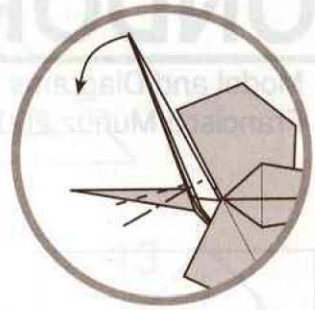

33. Reverse fold.

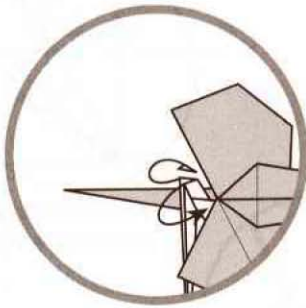

34. Model the stick.

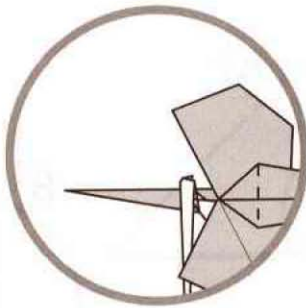

35. Valley fold the arm.

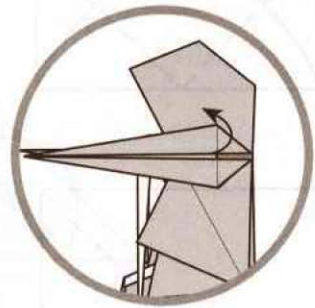

36. Open only the upper flap. The arm becomes 3D.

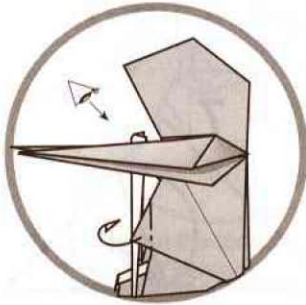

37. Mountain fold the flap.

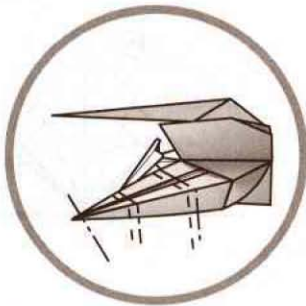

38. Crimp the arms. Then repeat steps 34 to 36 on the other arm.

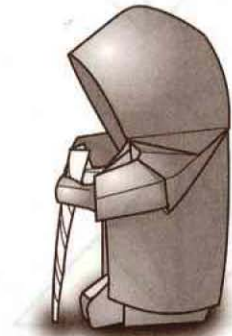
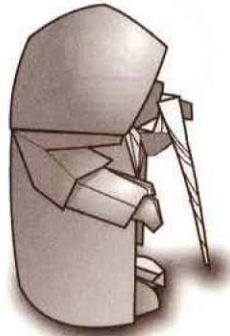

39. Twist the stick and model the monk to emphasize the 3D effect of the head, the arms and the body.

Creation & Diagram : N. Terry  
April 2003

<http://design.origami.free.fr>

# CONDOR

Model and Diagrams by  
Francisco Muñoz 2003

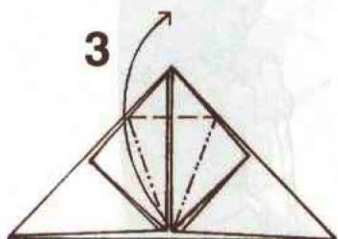
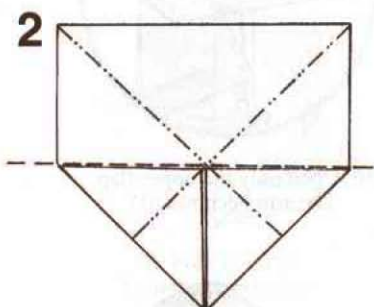
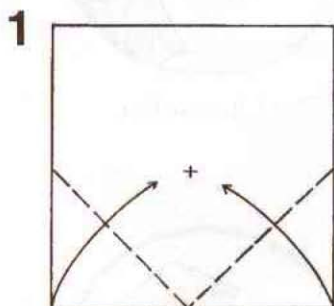
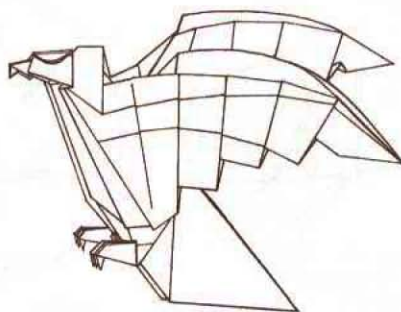

Lift top layer along the creases

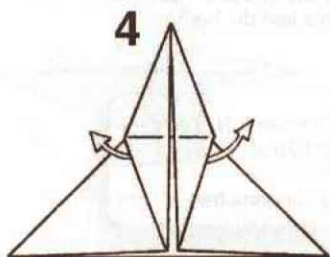

Pull out the loose paper

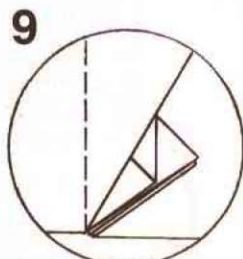
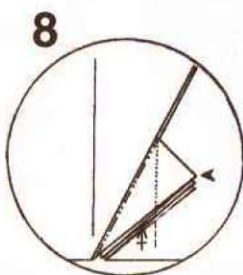
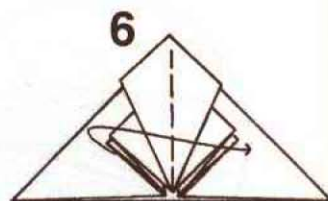
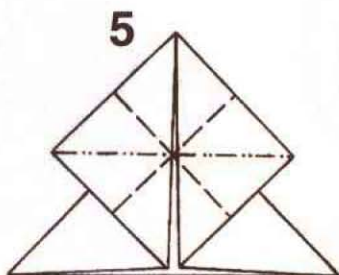

Return the layers  
folded on step 6

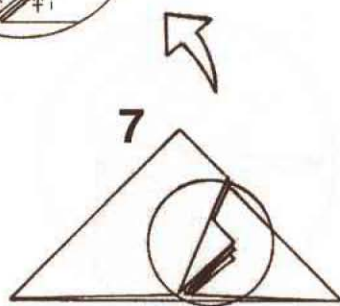

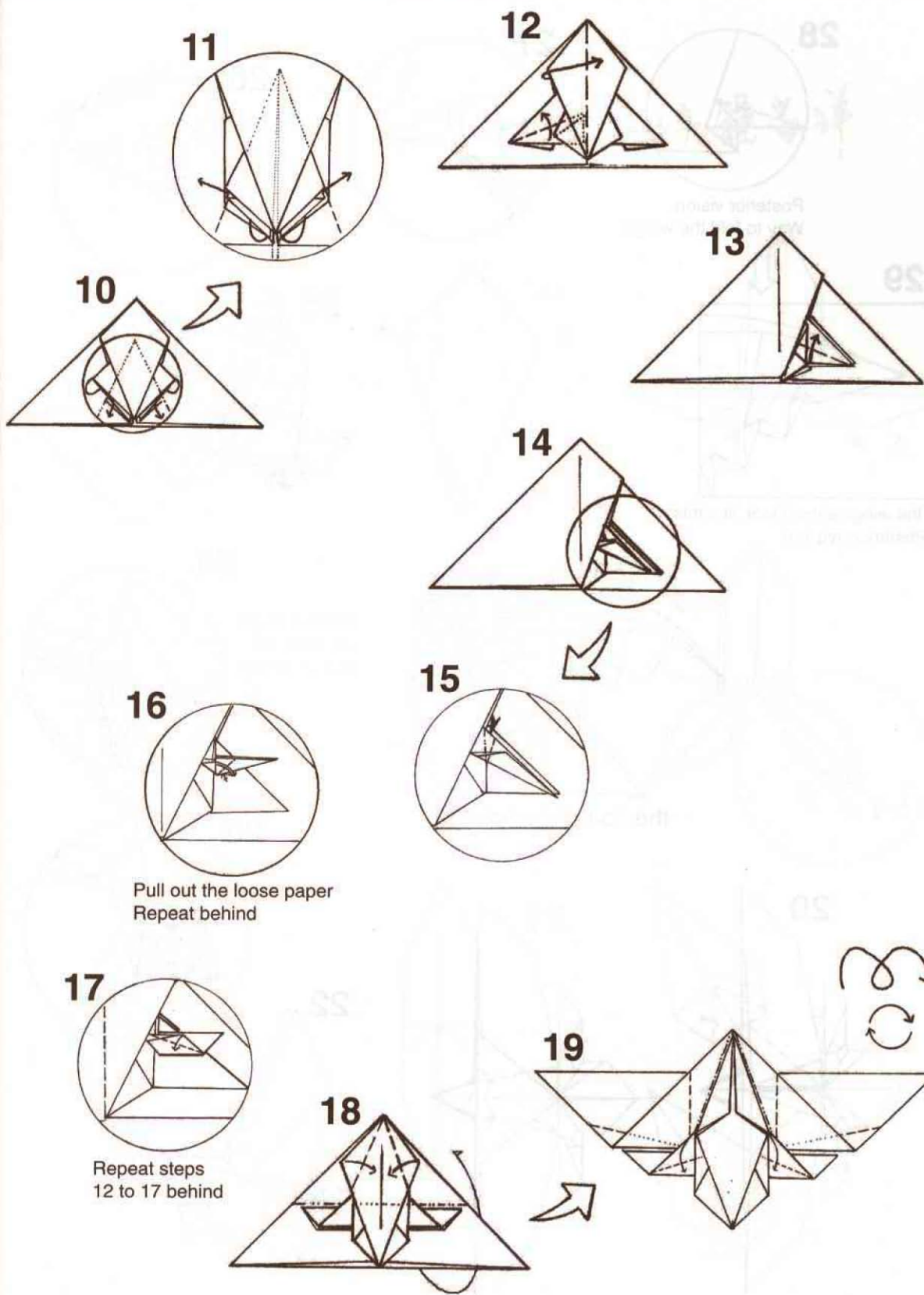

28

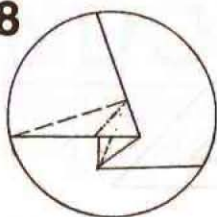

Posterior vision.  
Way to fold the wings

27

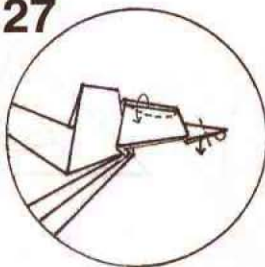

26

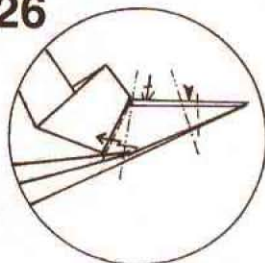

29

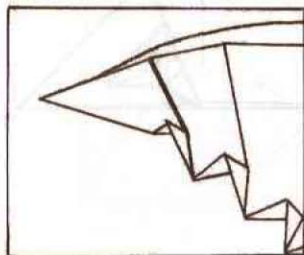

The wings should look like this  
(Posterior avision)

25

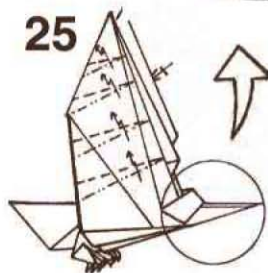

24

Repeat steps  
22 to 24 on  
the other side

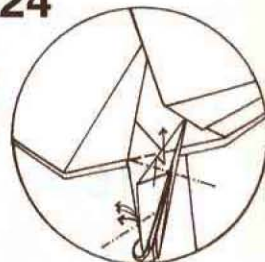

23

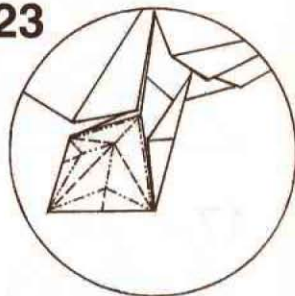

22

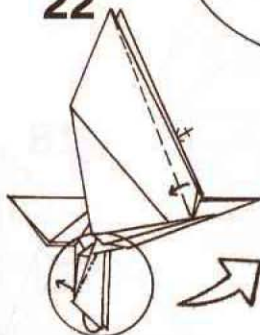

20

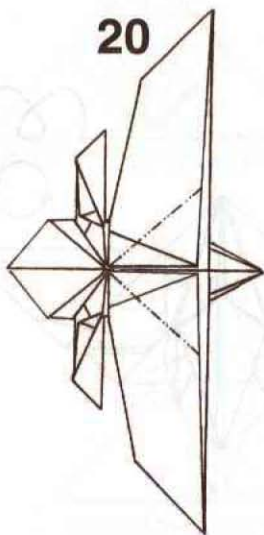

21

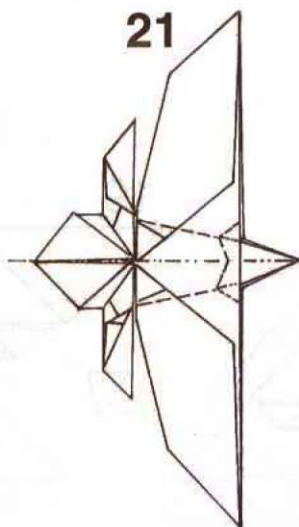

the completed condor

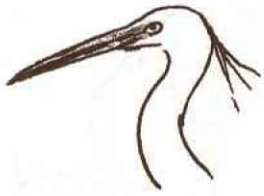

小白鹭

作图于2003年魏高洋

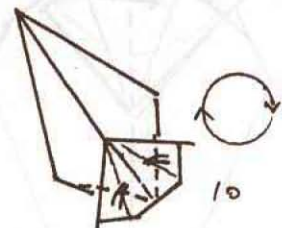
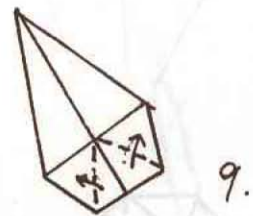
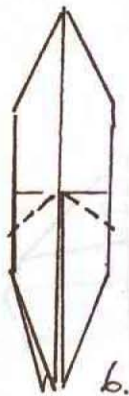
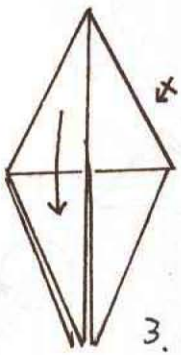
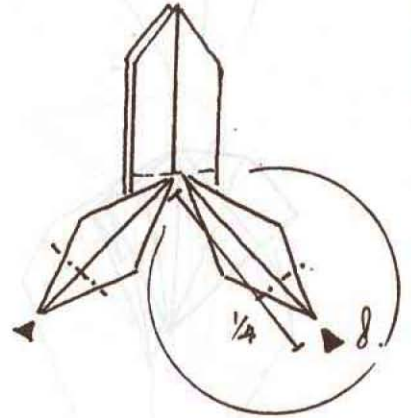
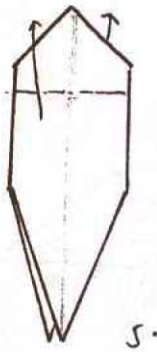
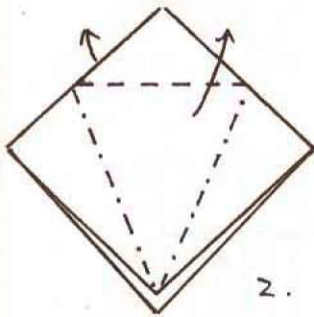
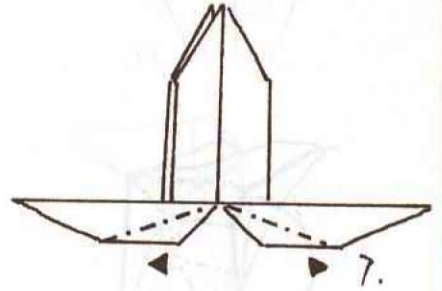
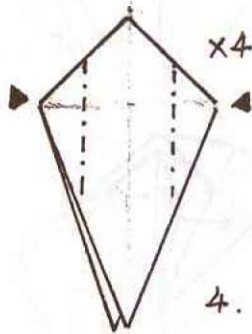
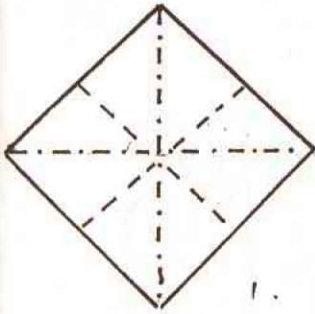

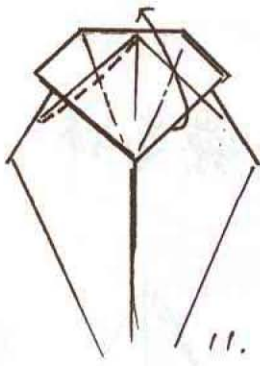

11.

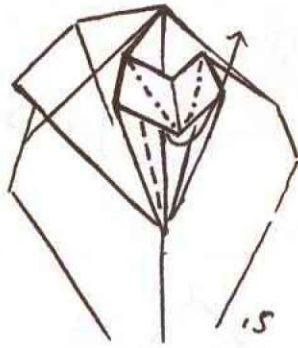

15

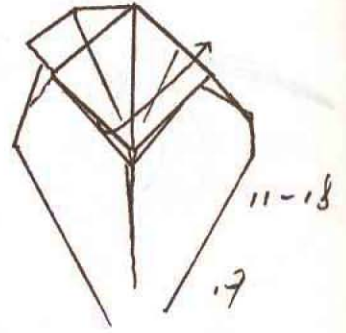

17

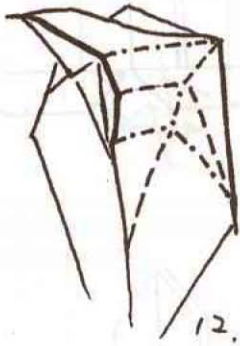

12.

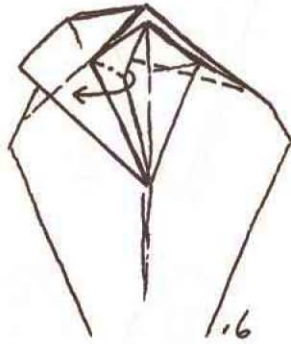

16

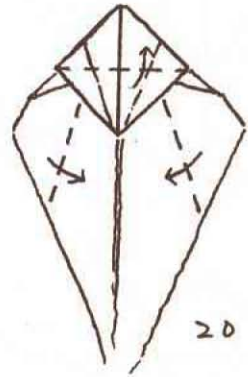

20

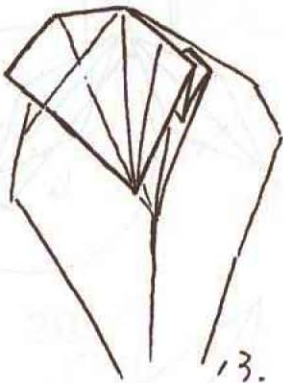

13.

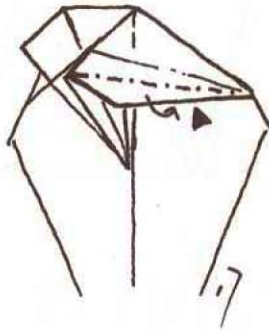

17

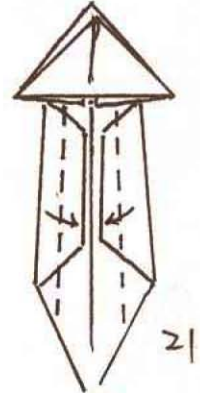

21

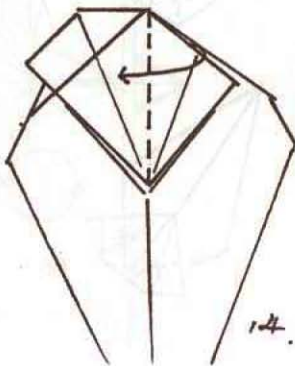

14.

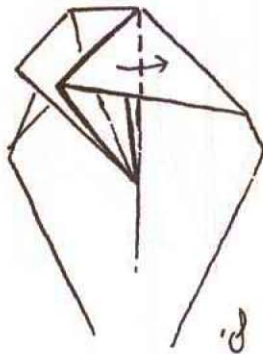

18

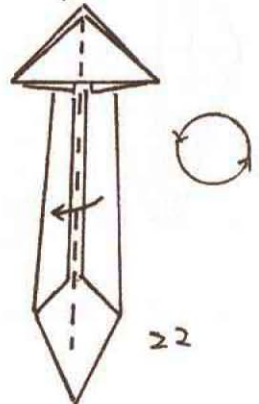

22



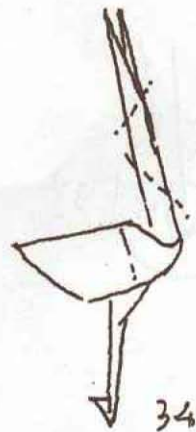
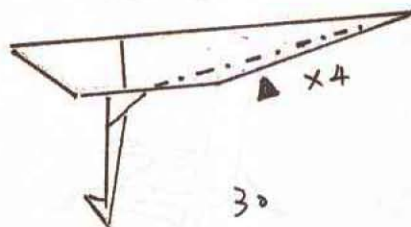
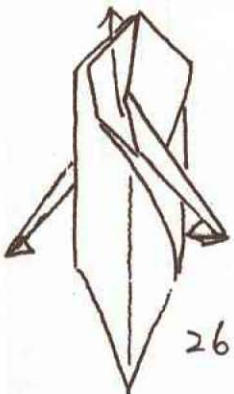
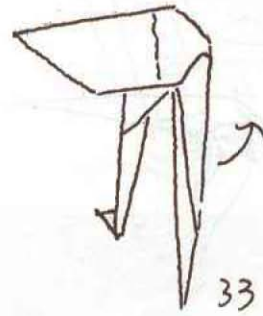
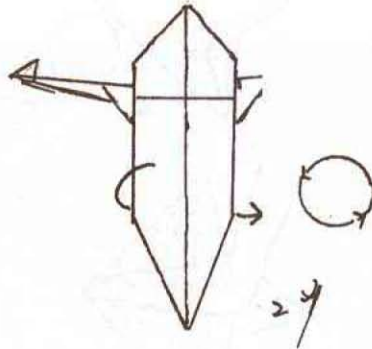
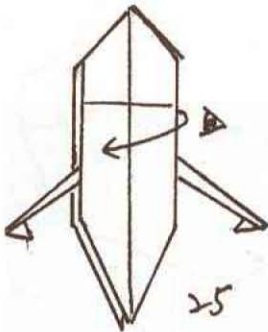
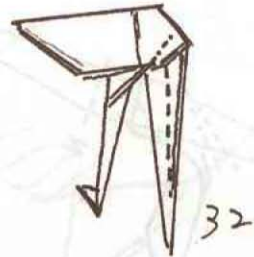
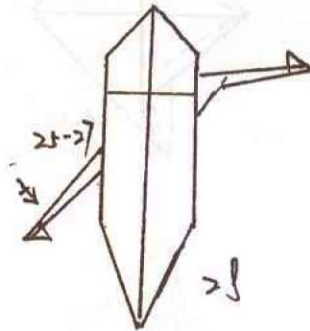
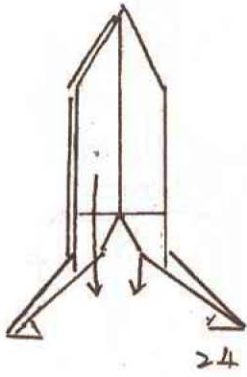
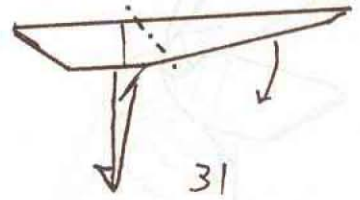
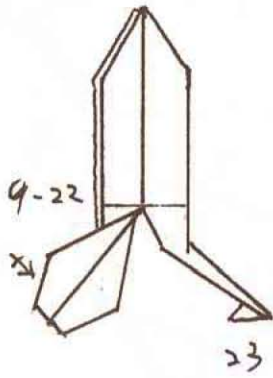

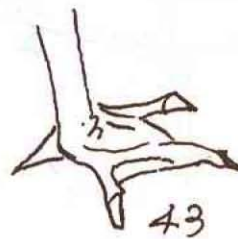
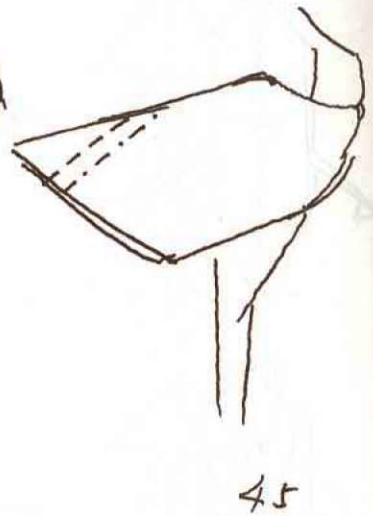
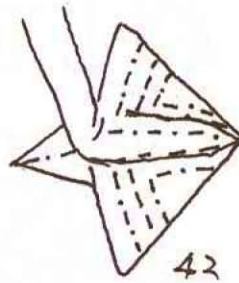
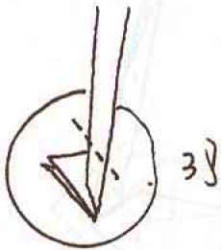
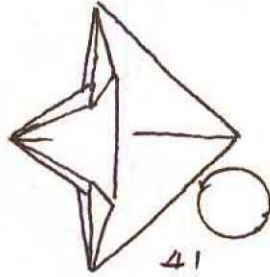
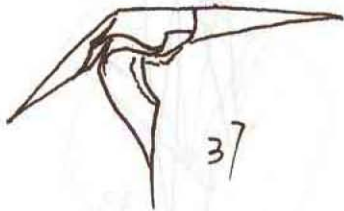
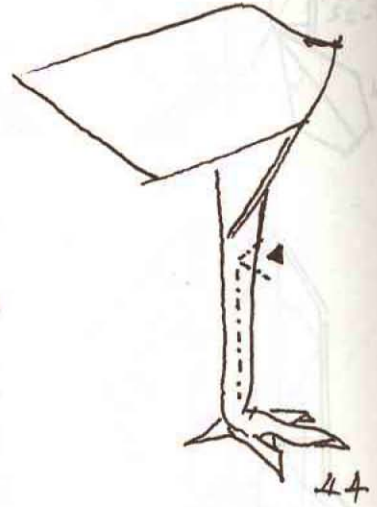
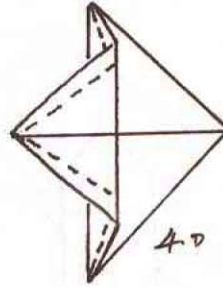
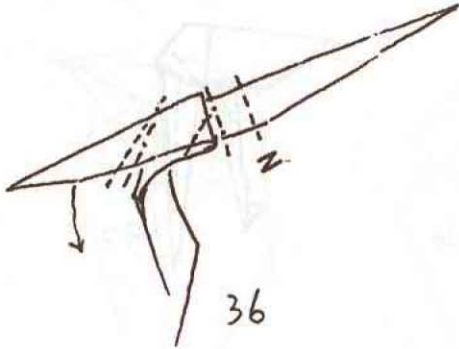
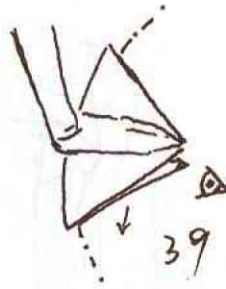
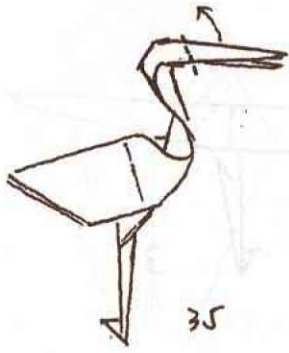

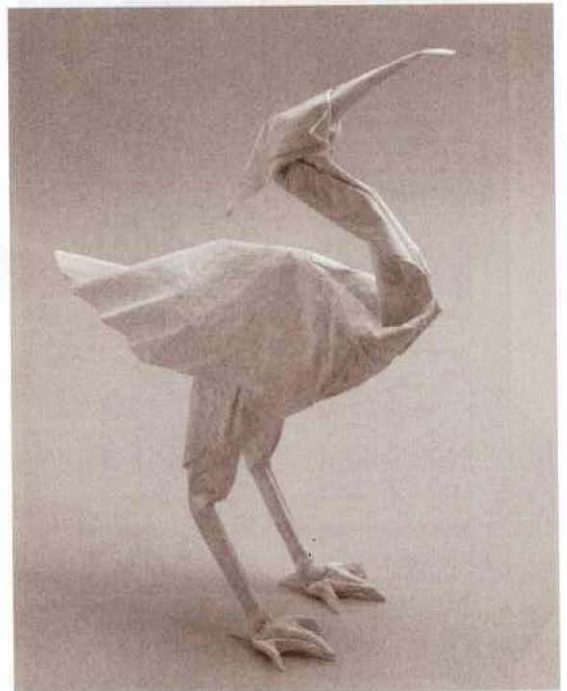
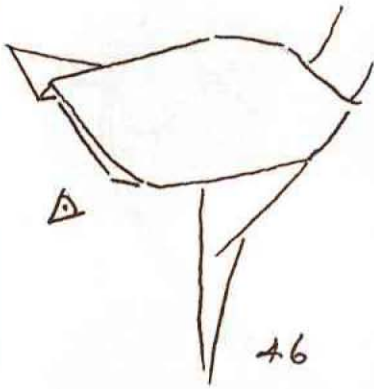

# Acantocino

(c) Manuel Sirgo Alvarez  
2002-ESPAÑA

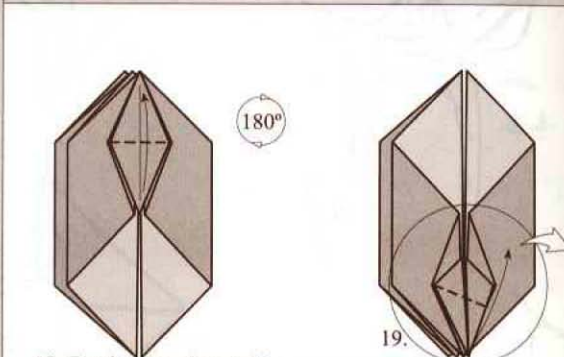
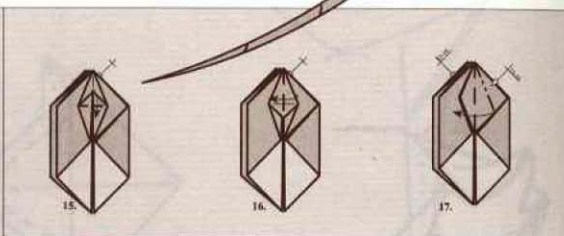
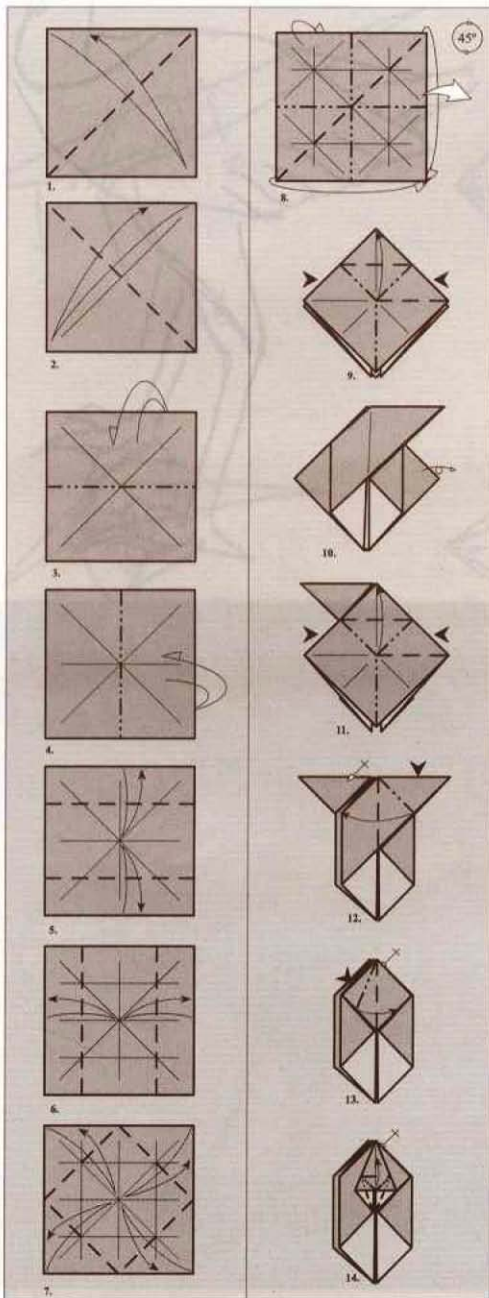
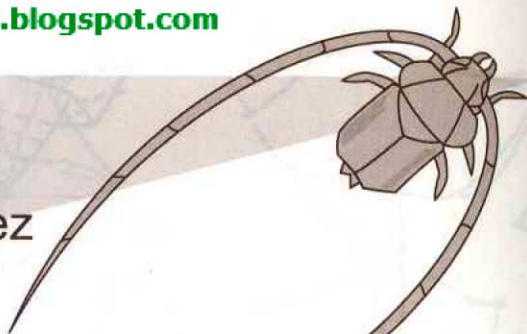

18. Empieza en el paso 18 de la Tabaquera.

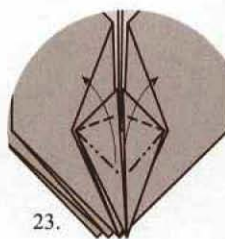
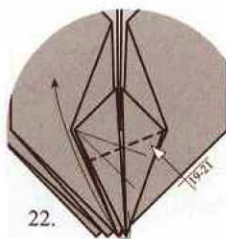
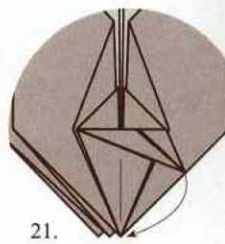
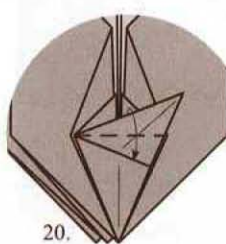

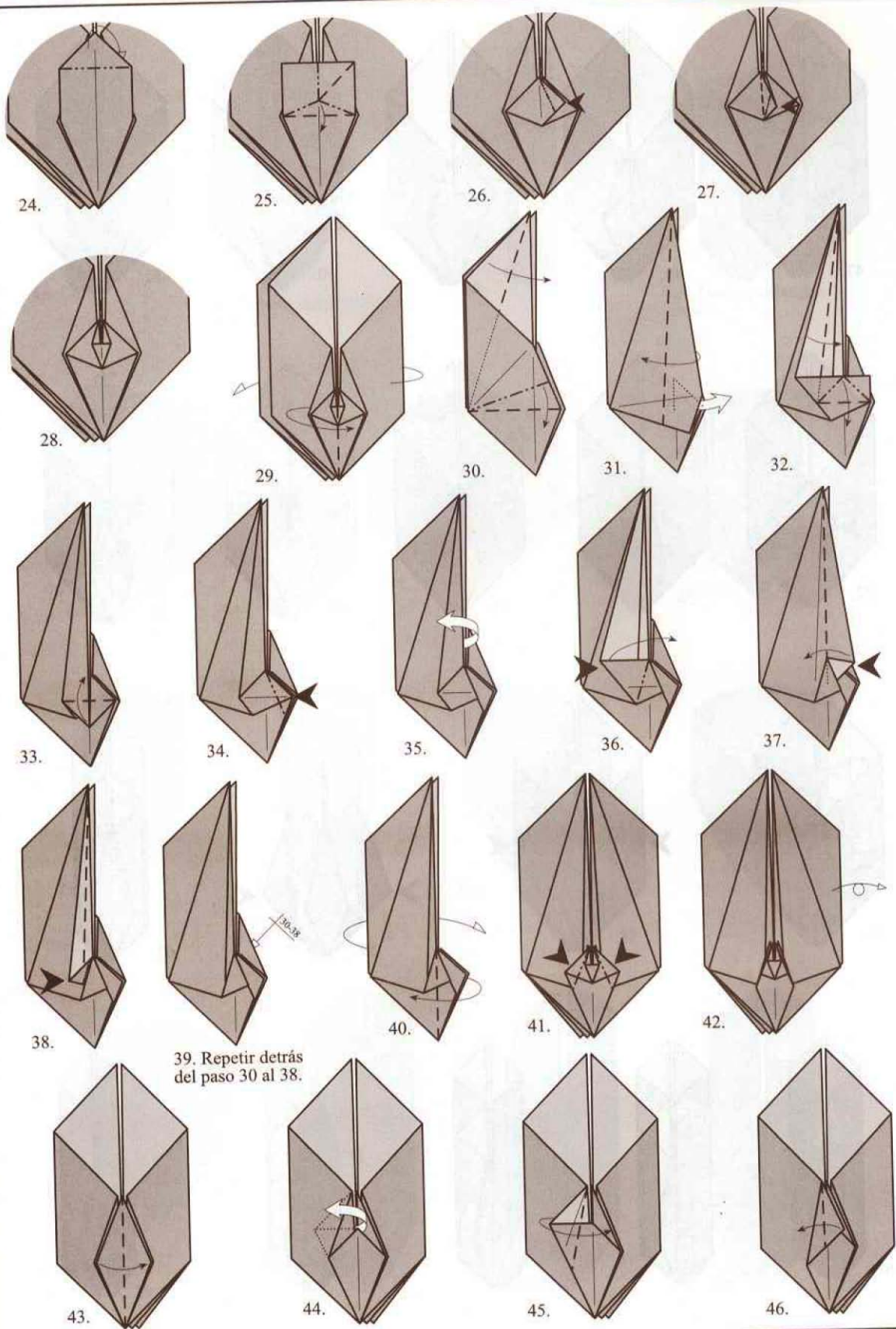

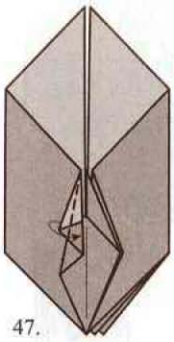

47.

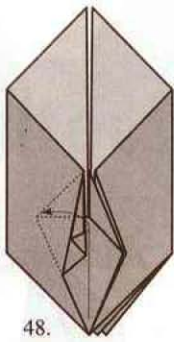

48.

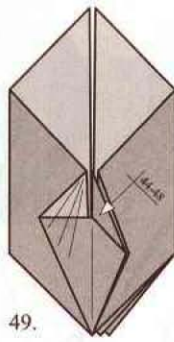

49.

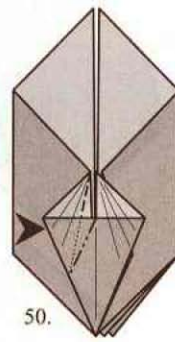

50.

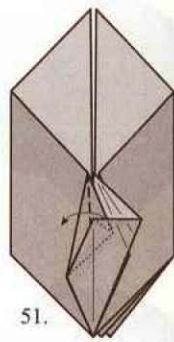

51.

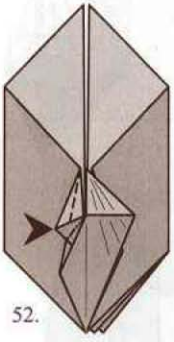

52.

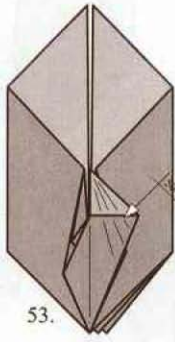

53.

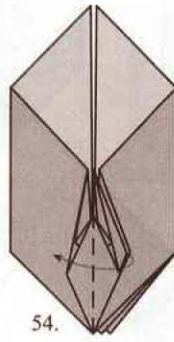

54.

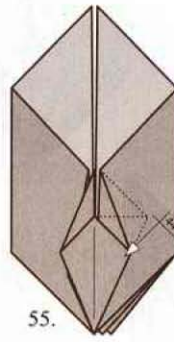

55.

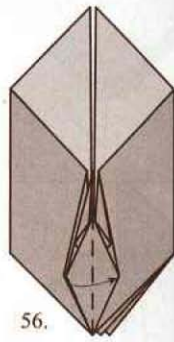

56.

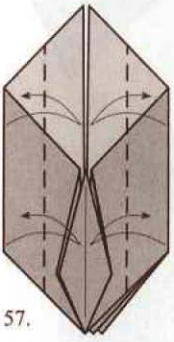

57.

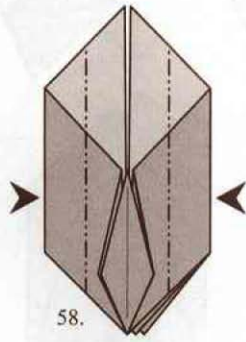

58.

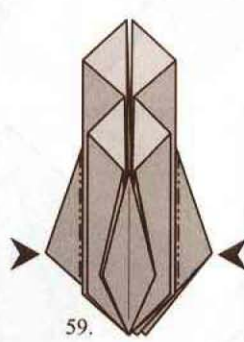

59.

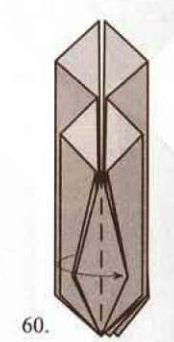

60.

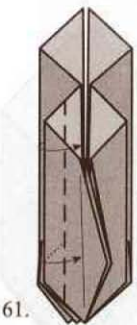

61.



62.

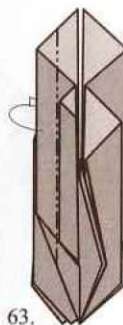

63.

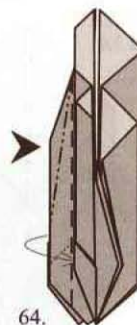

64.



65.

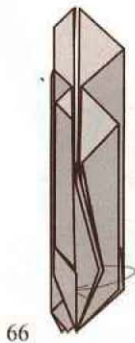

66.

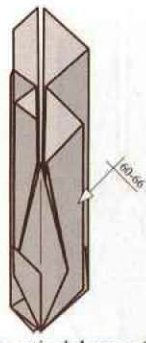

67. Repetir del paso 60 al 66.

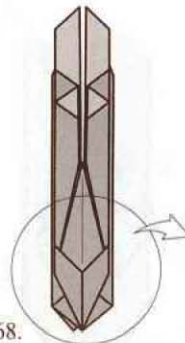

68.

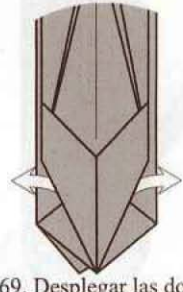

69. Desplegar las dos capas.

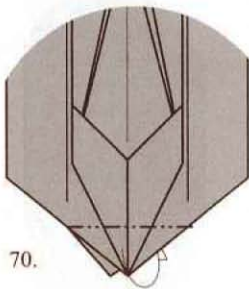

70.

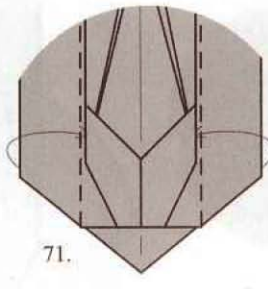

71.

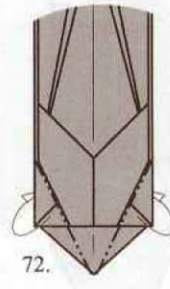

72.

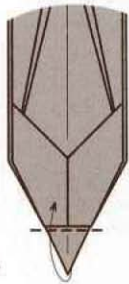

73.

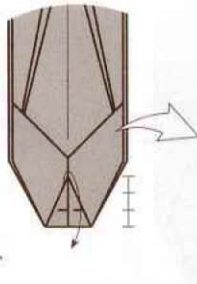

74.

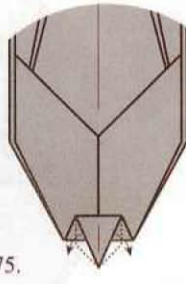

75.

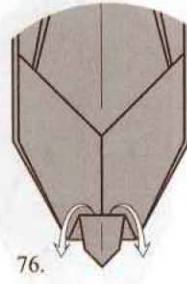

76.

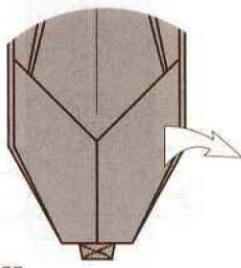

77.

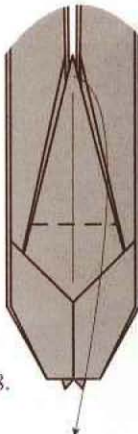

78.

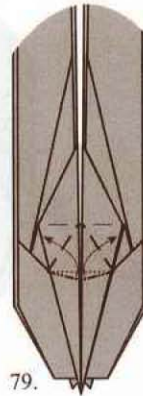

79.

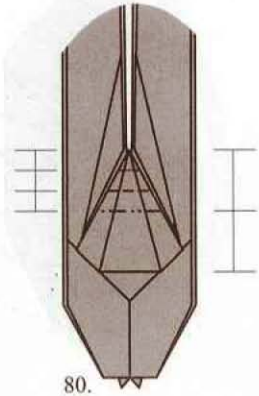

80.

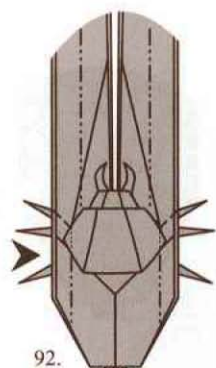
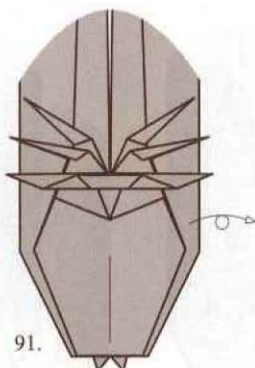
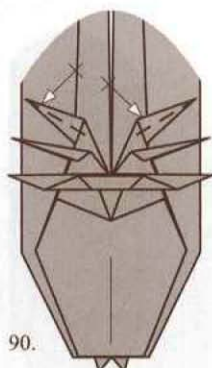
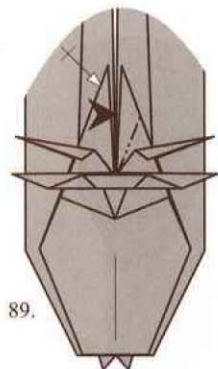
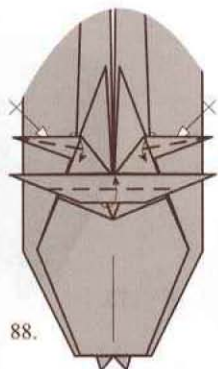
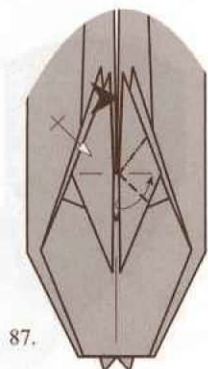
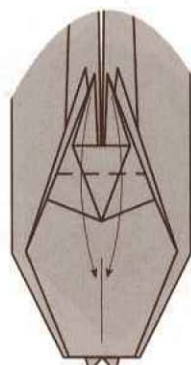
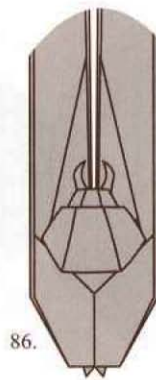
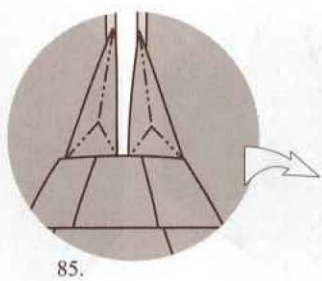
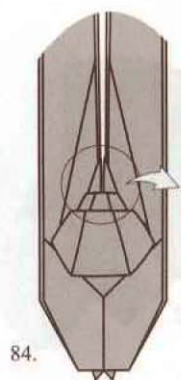
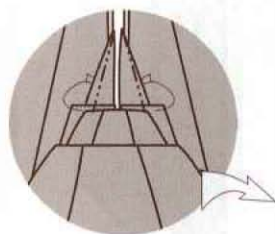
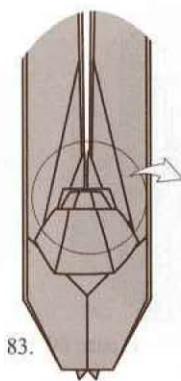
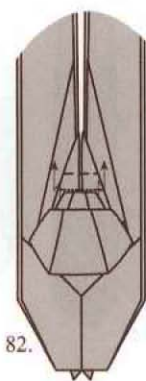
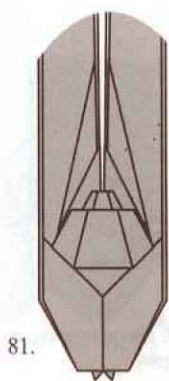



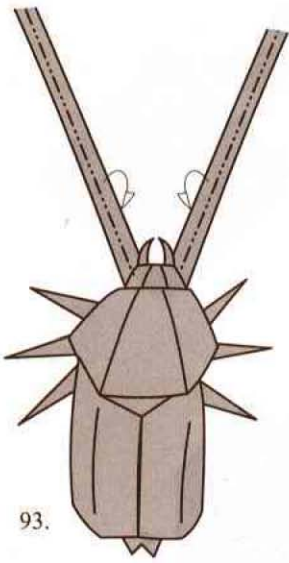

93.

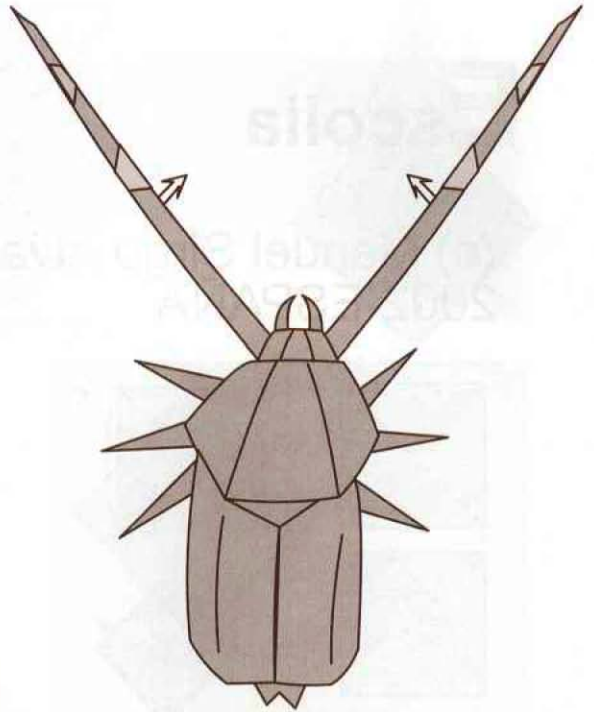

94. Desplegar la antena.

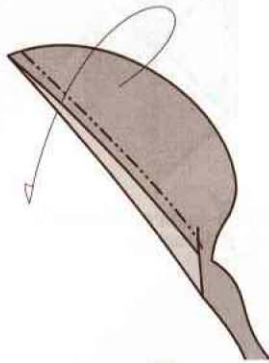

95.

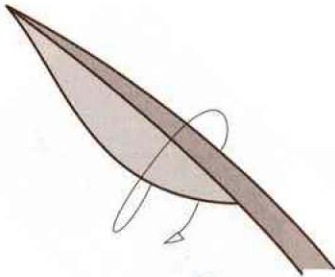

96.

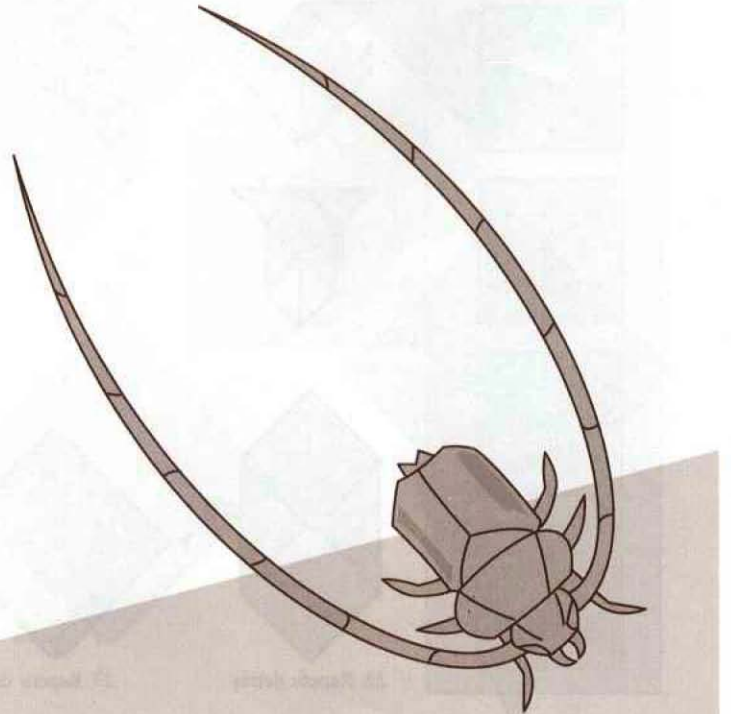

# Escolia

(c) Manuel Sirgo Alvarez  
2002-ESPAÑA

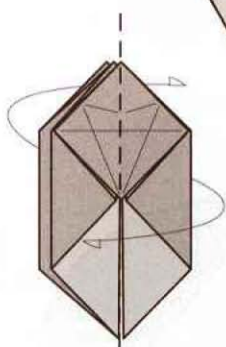
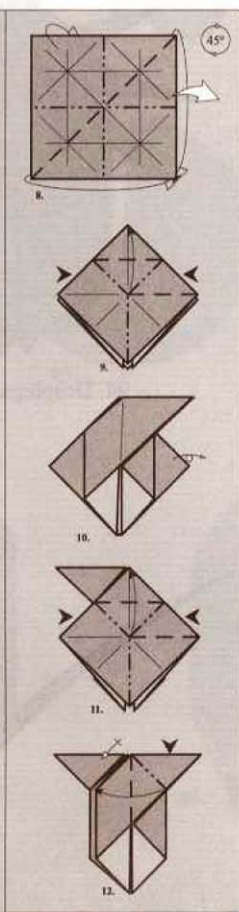
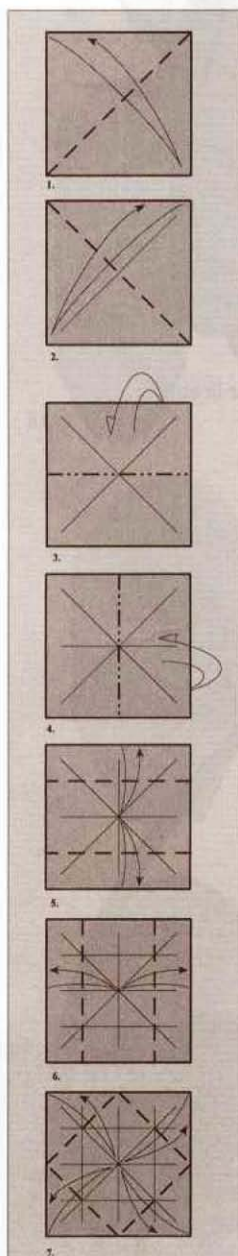
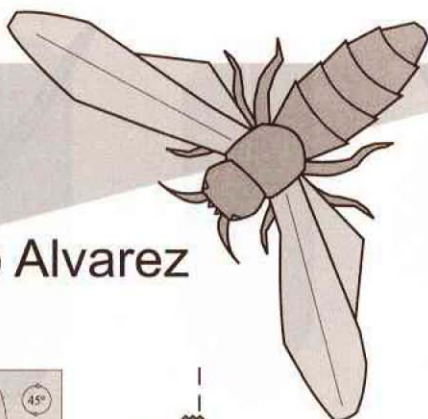

18. Empieza en el paso 12 de la Tabaquera.



19.

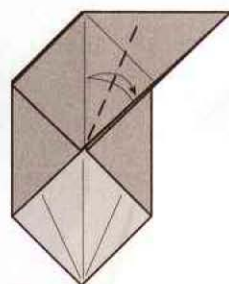

20.

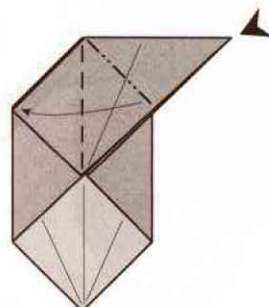

21.

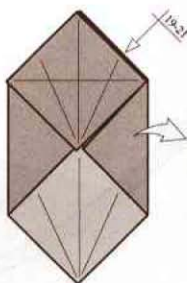

22. Repetir detrás

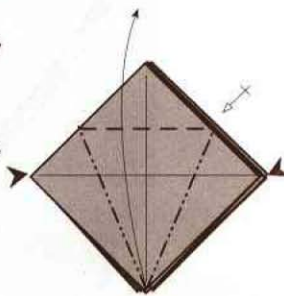

23. Repetir detrás

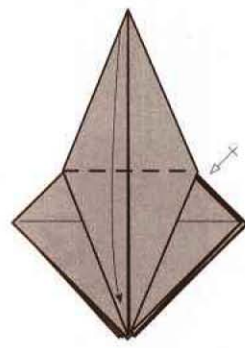

24. Repetir detrás

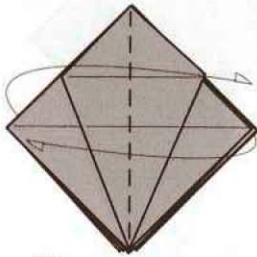

25.

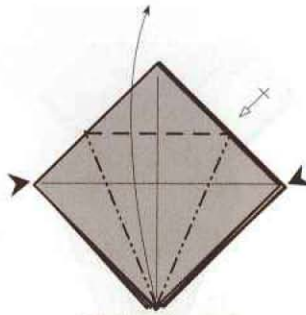

26. Repetir detrás

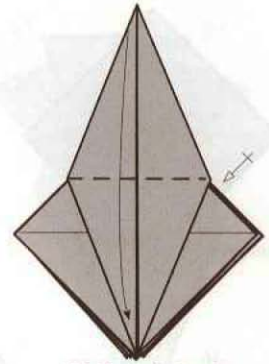

27. Repetir detrás

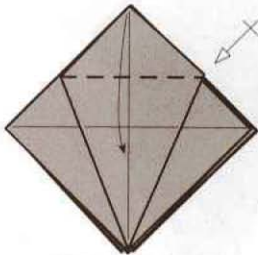

28. Repetir detrás

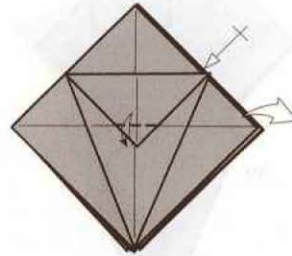

29. Repetir detrás

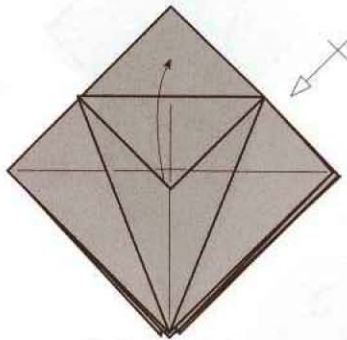

30. Repetir detrás

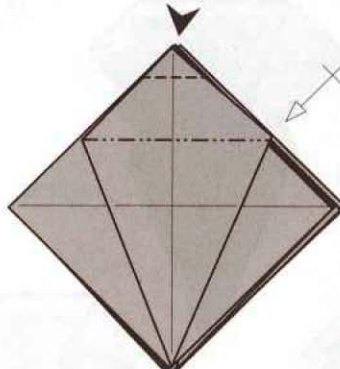

31. Repetir detrás

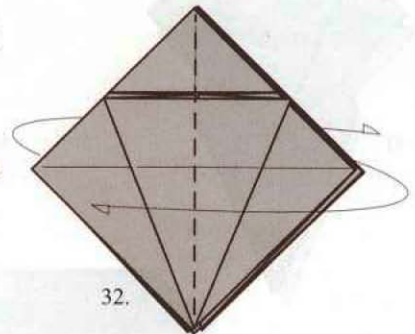

32.

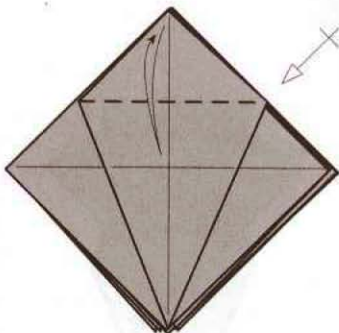

33. Repetir detrás

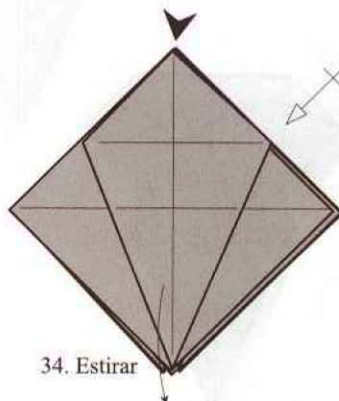

34. Estirar

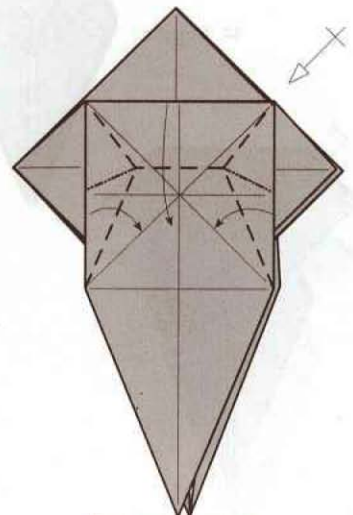

35. Repetir detrás

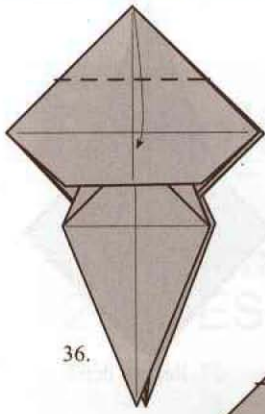

36.

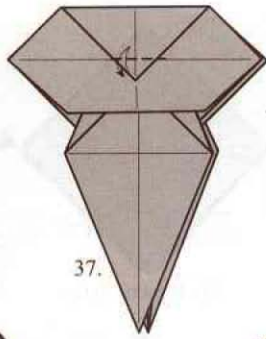

37.

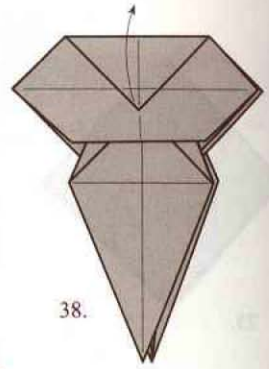

38.

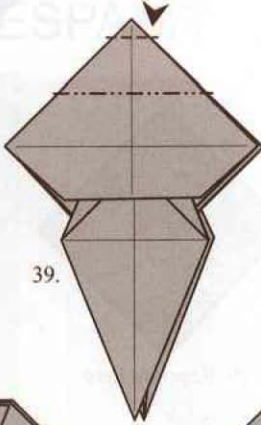

39.

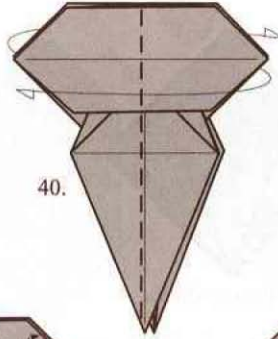

40.

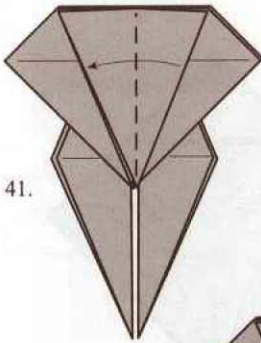

41.

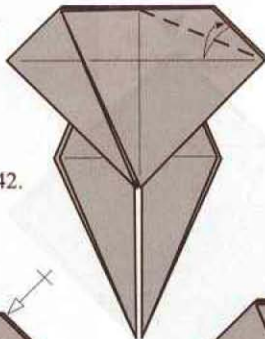

42.

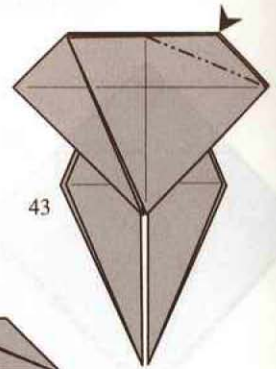

43.

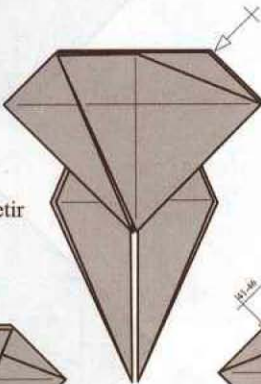

44. Repetir

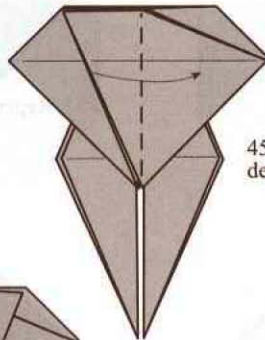

45. Doblar hacia la derecha las dos puntas

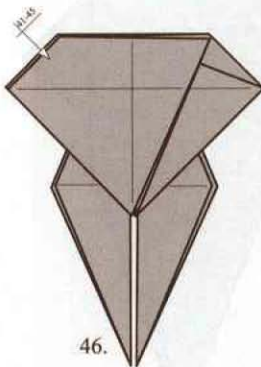

46.

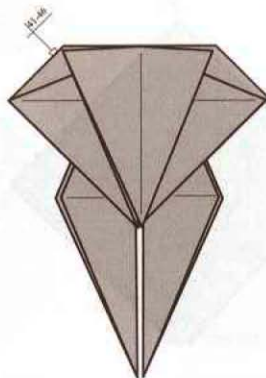

47. Repetir detrás

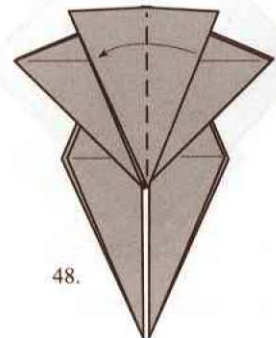

48.

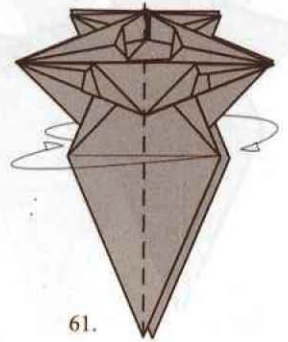
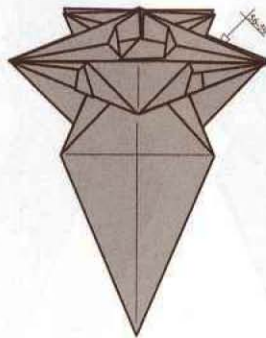
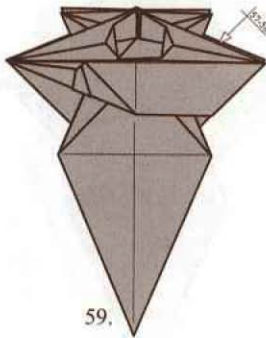
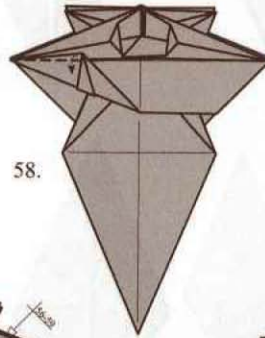
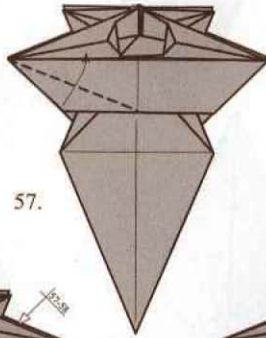
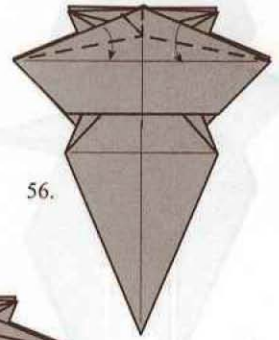
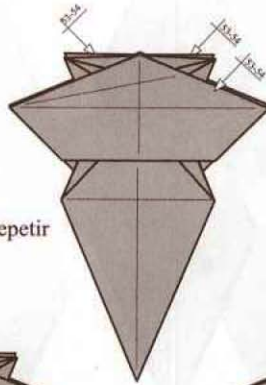
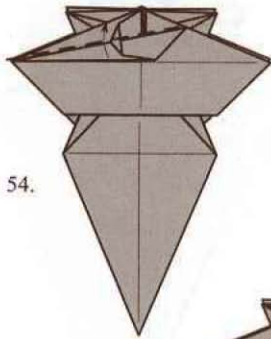
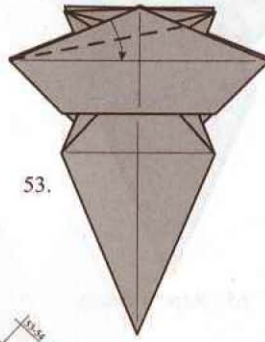
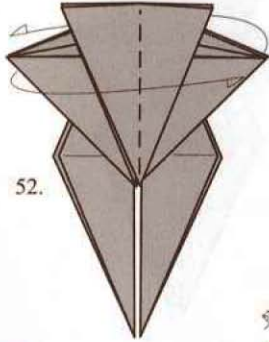
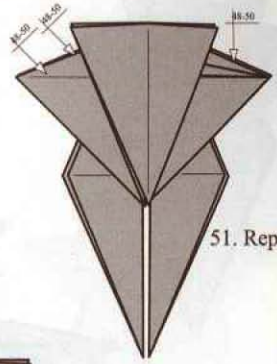
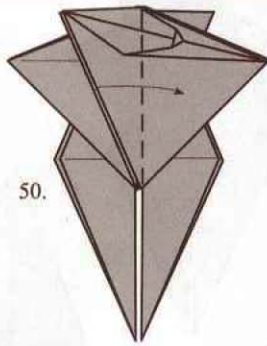
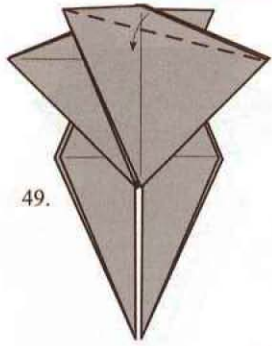

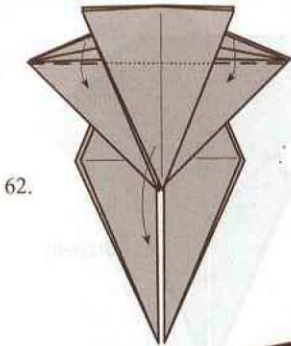

62.

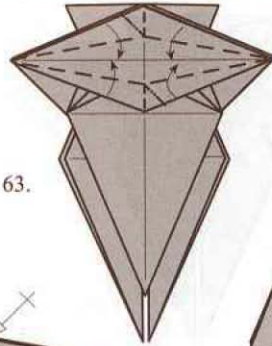

63.

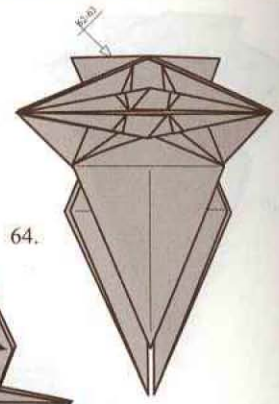

64.

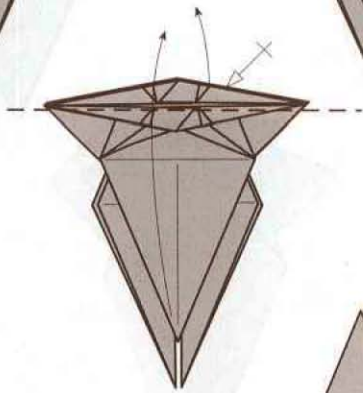

65. Repetir detrás

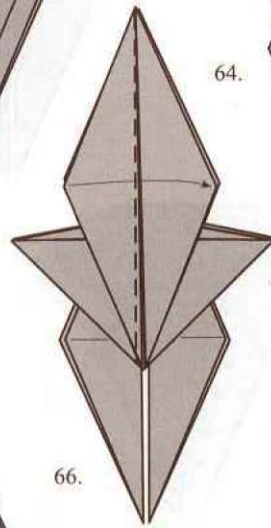

66.

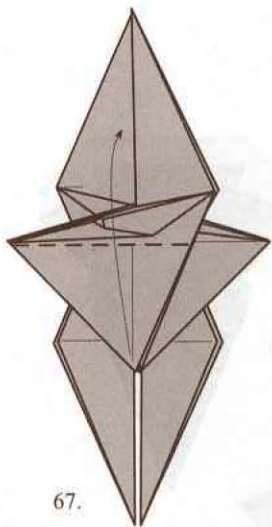

67.

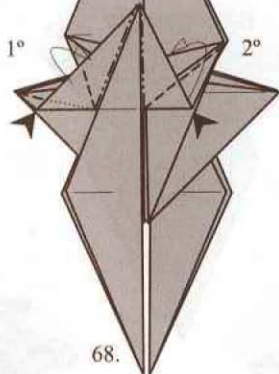

68.

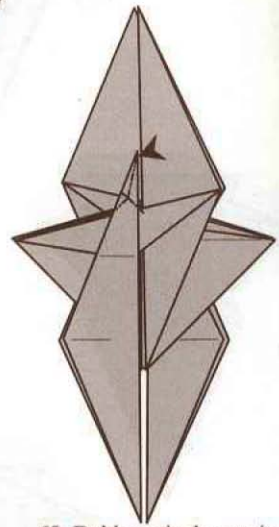

69. Doble oreja de conejo (dos capas hacia delante)

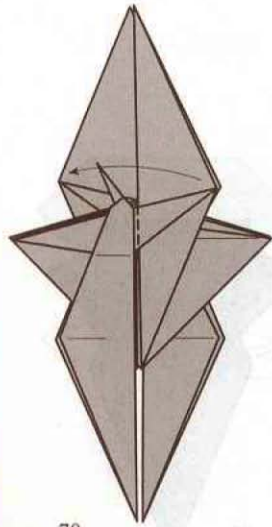

70.

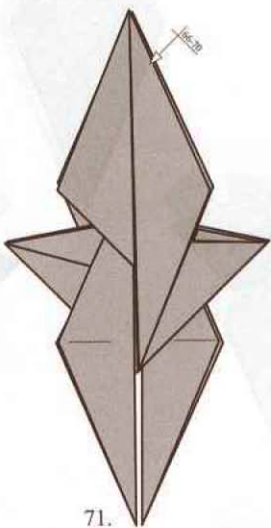

71.

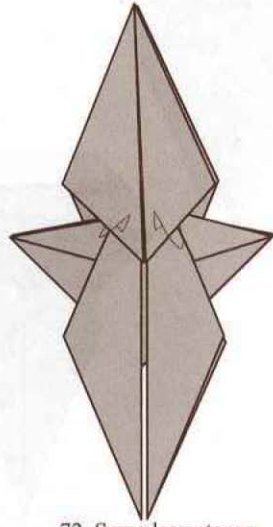

72. Sacar las antenas hacia delante

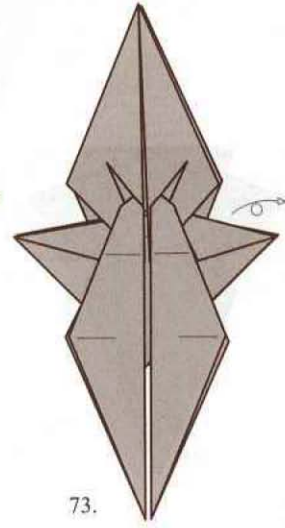

73.

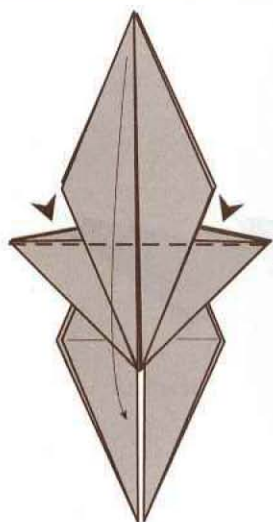

74. Bajar y aplastar el centro

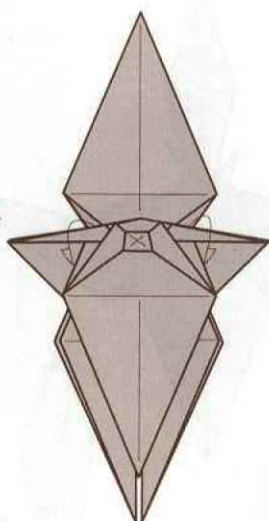

75. Bajar dos capas

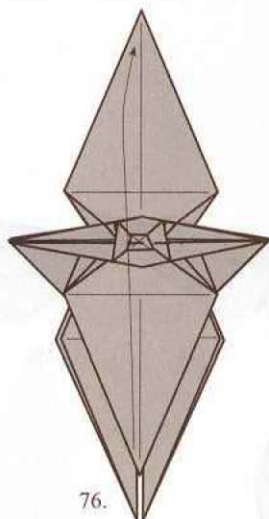

76.

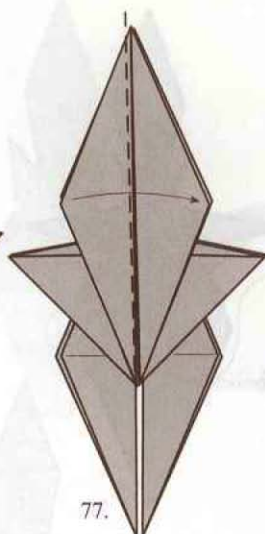

77.

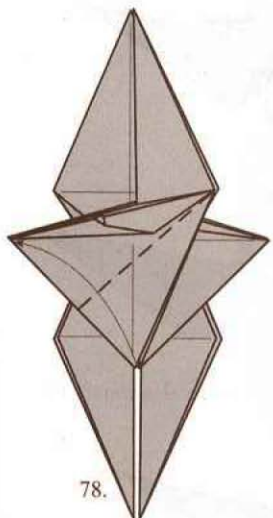

78.

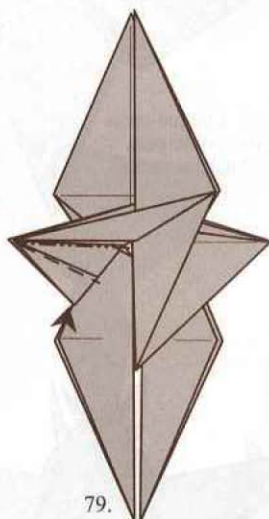

79.

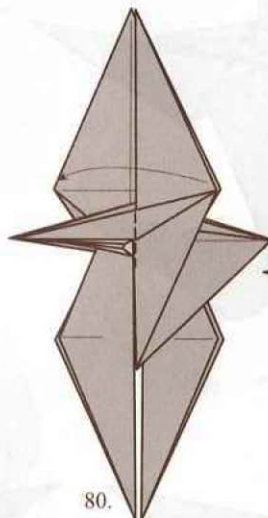

80.

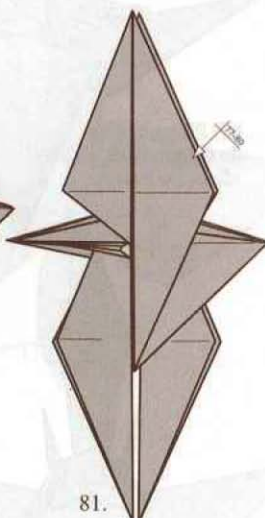

81.

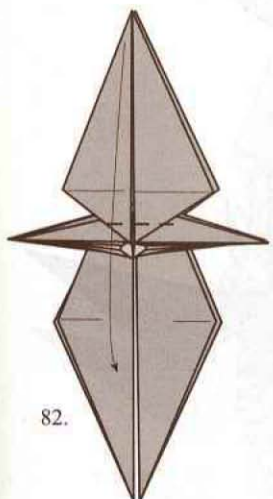

82.

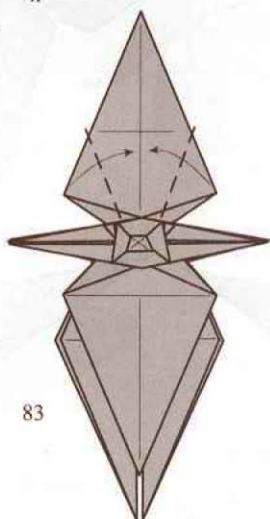

83

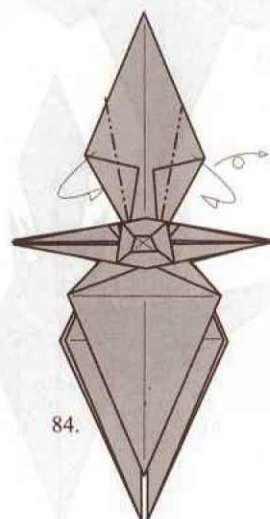

84.

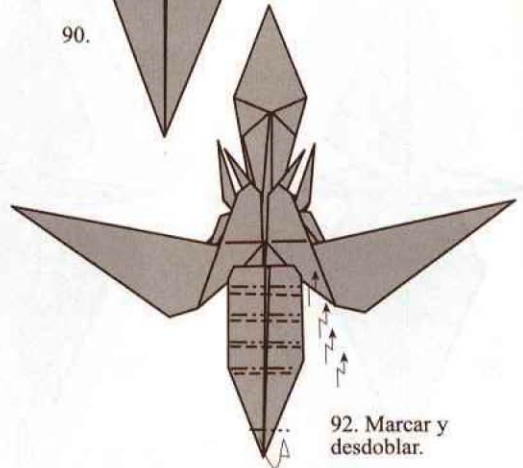
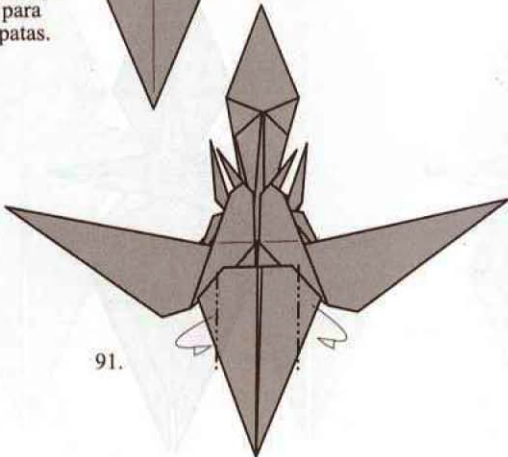
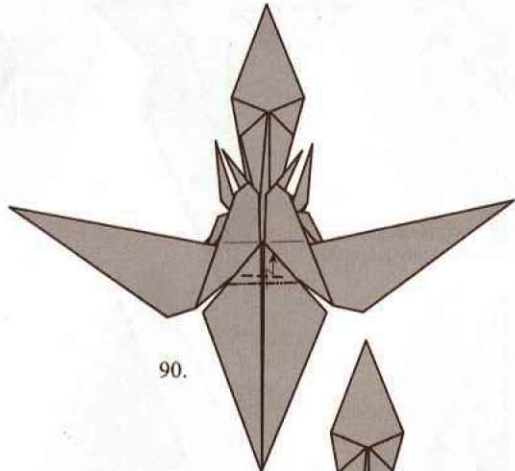
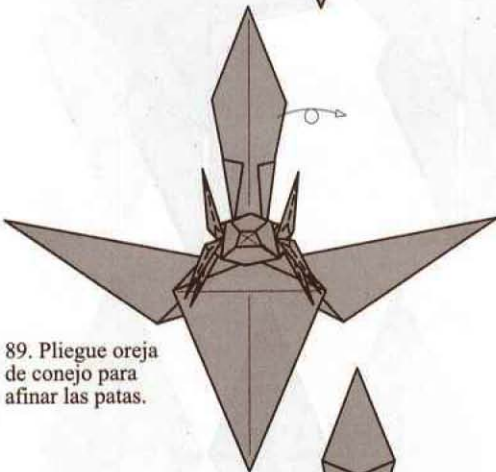
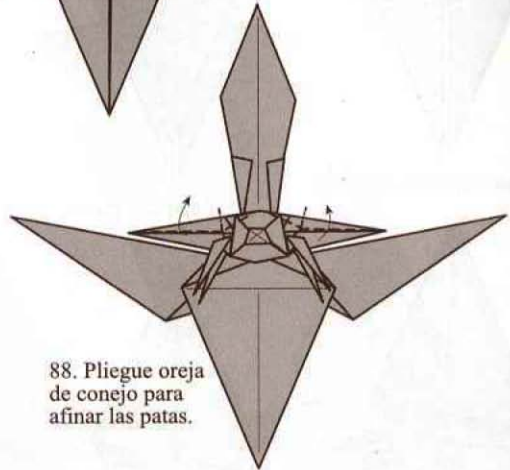
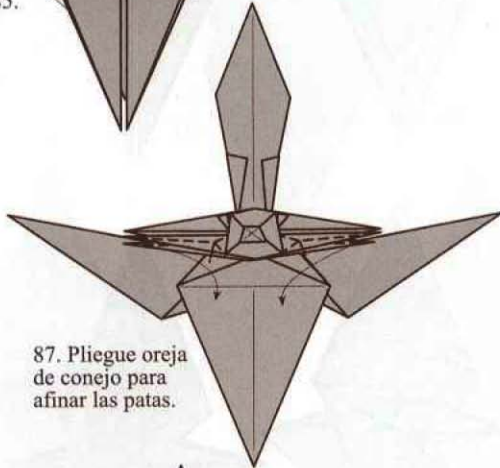
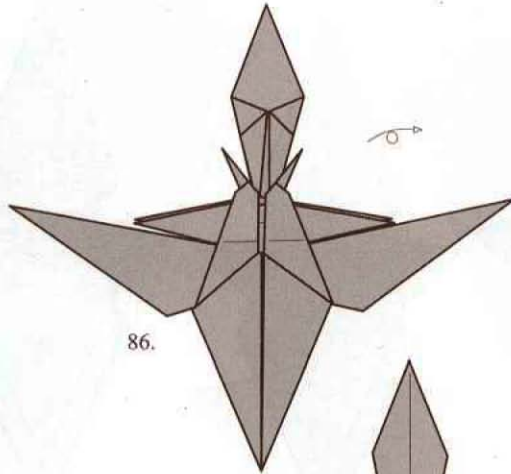
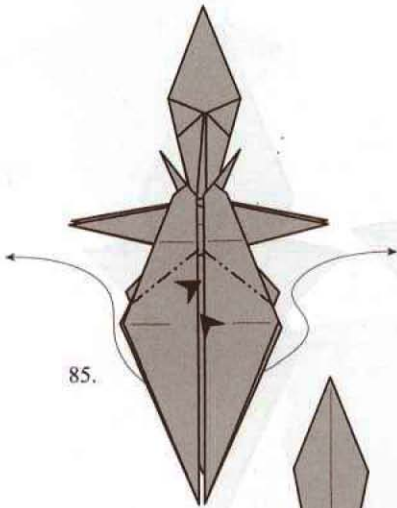



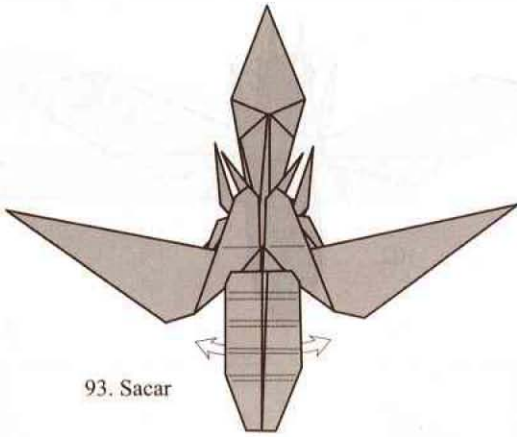

93. Sacar

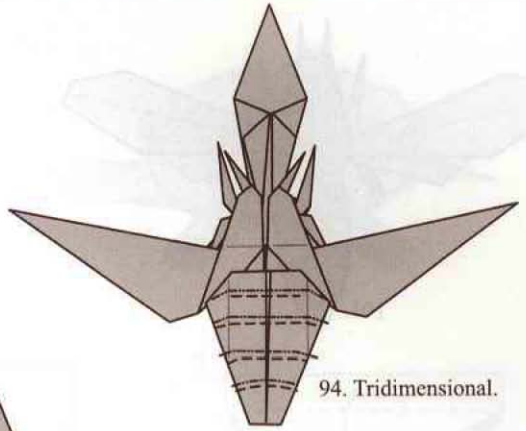

94. Tridimensional.

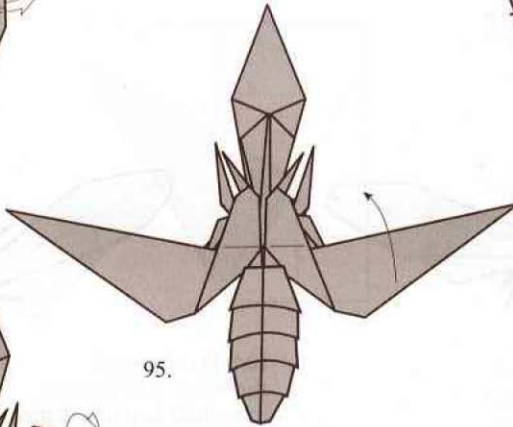

95.

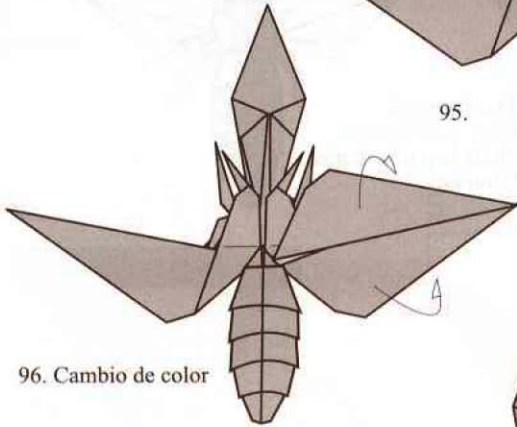

96. Cambio de color

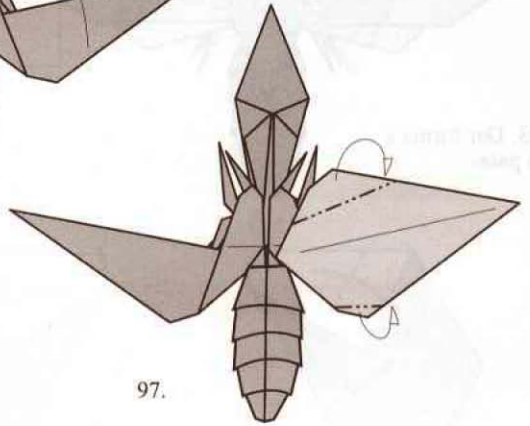

97.

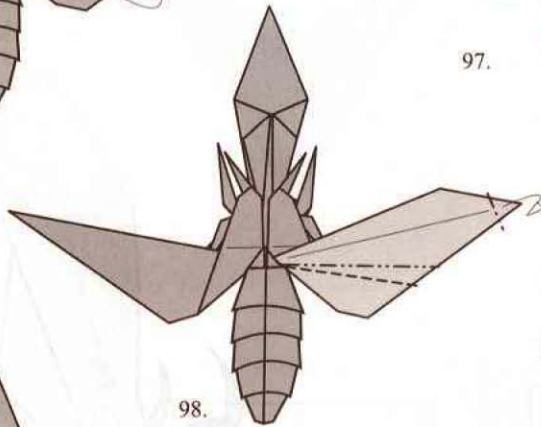

98.

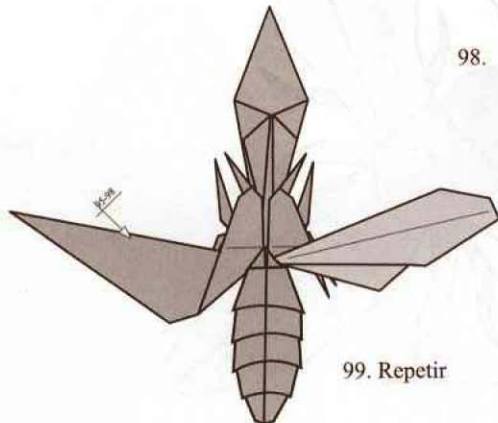

99. Repetir

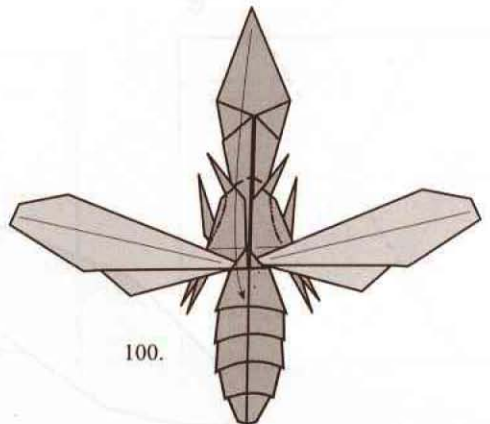

100.

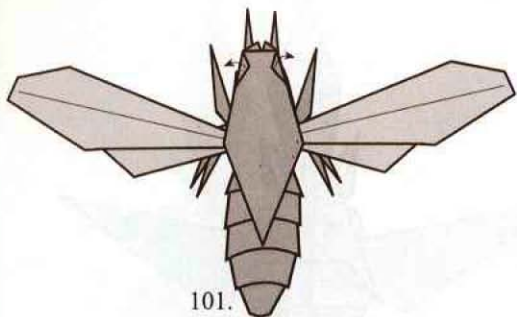

101.

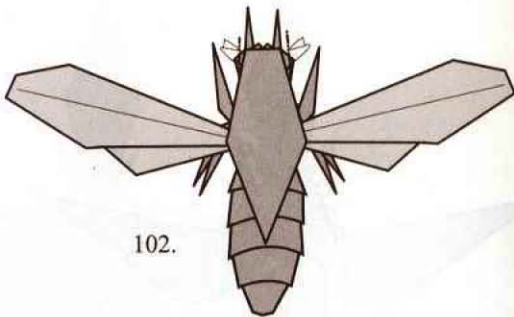

102.

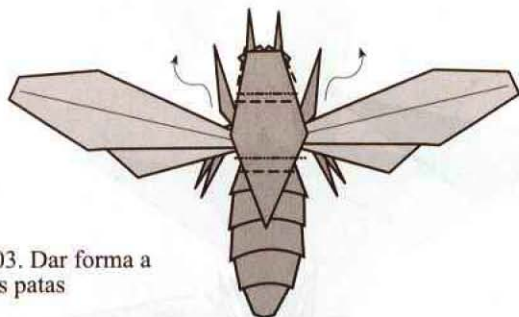

103. Dar forma a las patas



104. Dar forma al abdomen y a las alas. Introducir la punta dentro del abdomen



# Turtle

Eran Leiserowitz

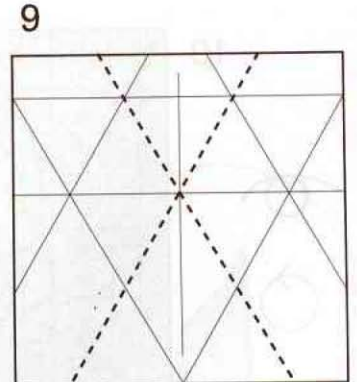
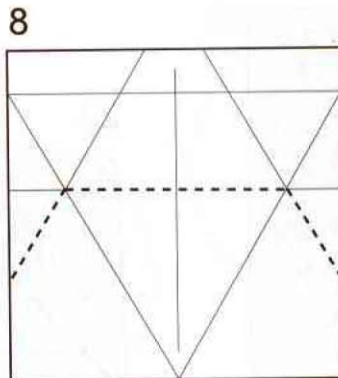
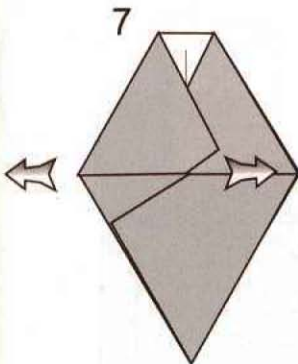
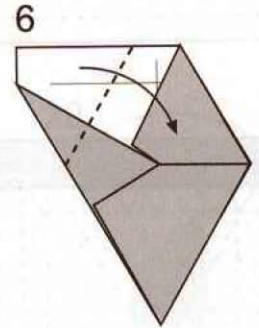
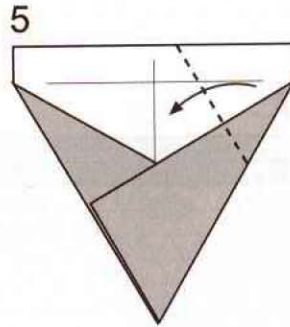
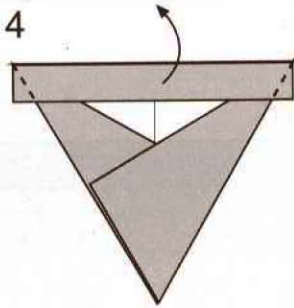
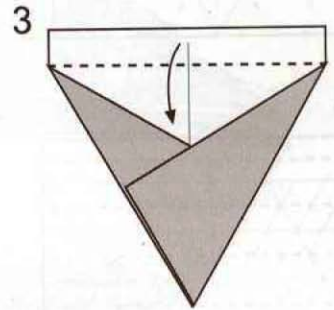
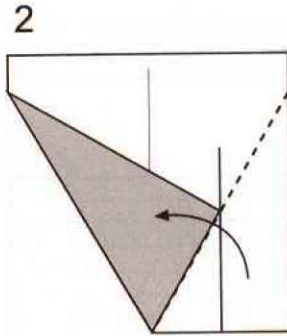
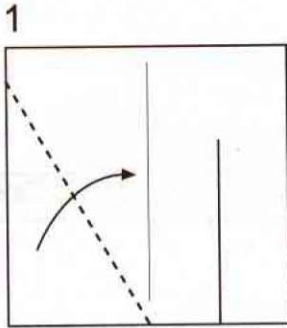
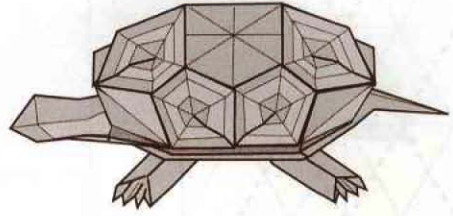

10

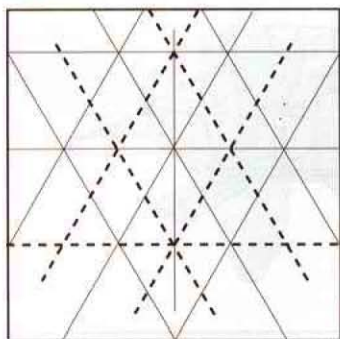

11

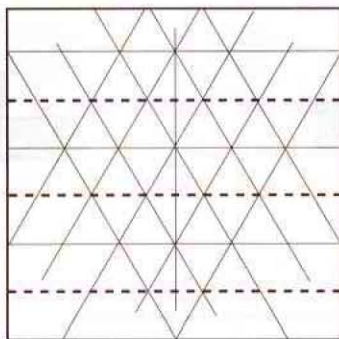

12

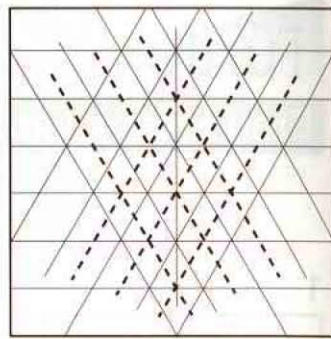

13

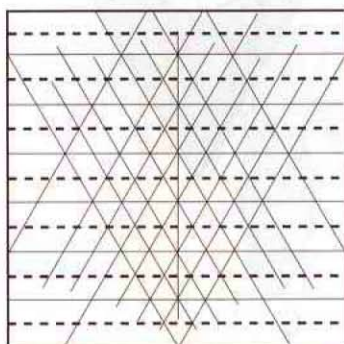

14

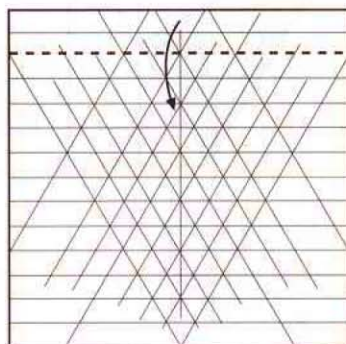

15

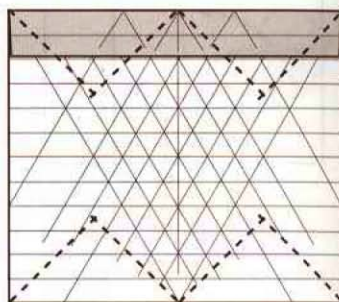

16

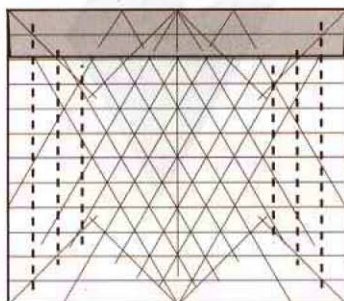

17

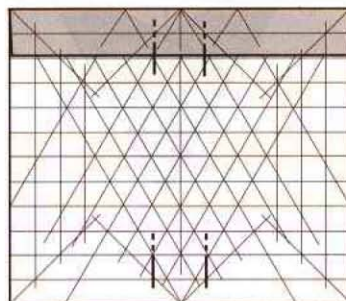

18

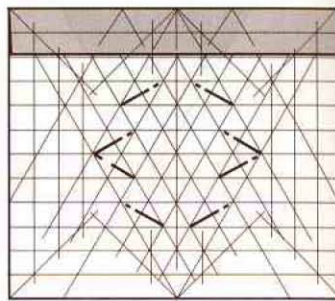

19

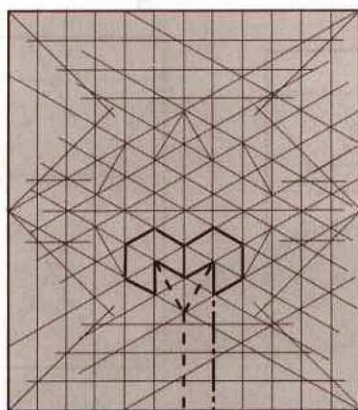

20

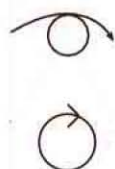
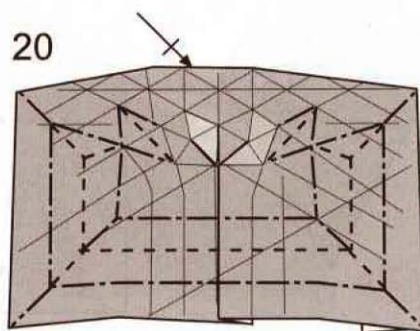

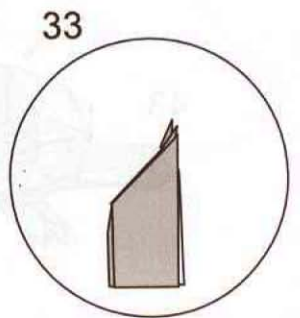
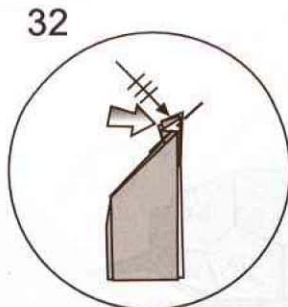
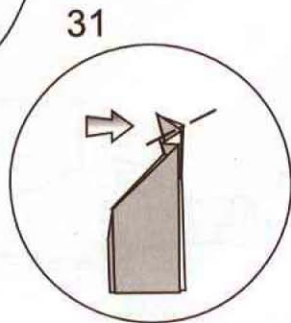
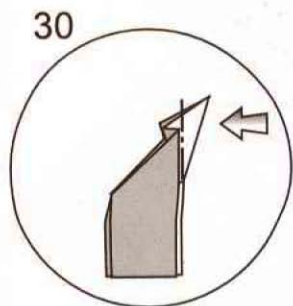
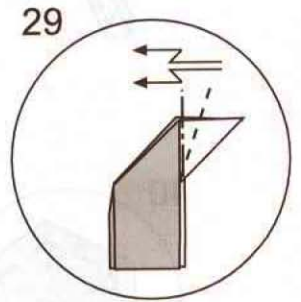
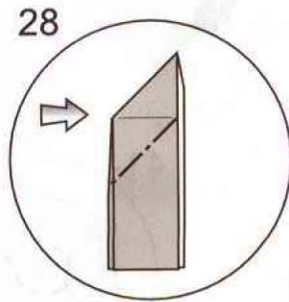
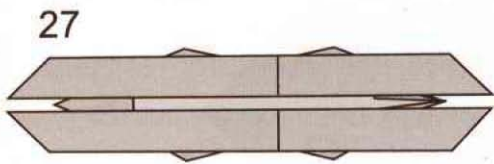
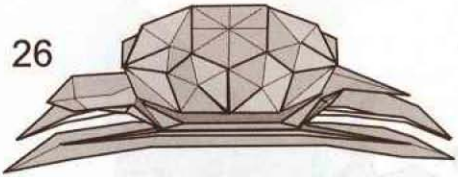
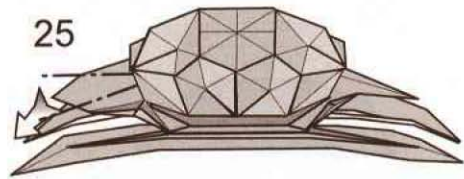
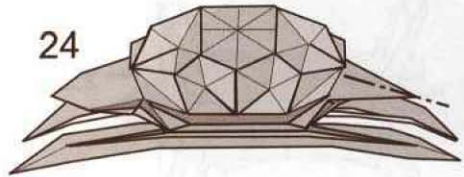
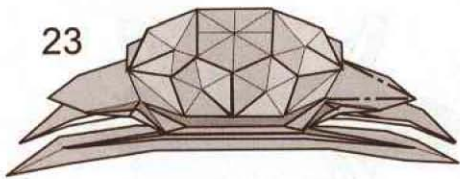
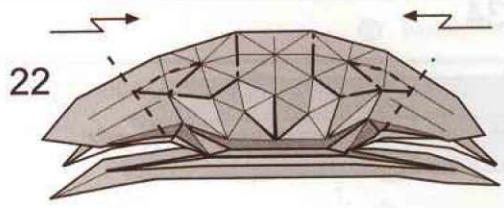
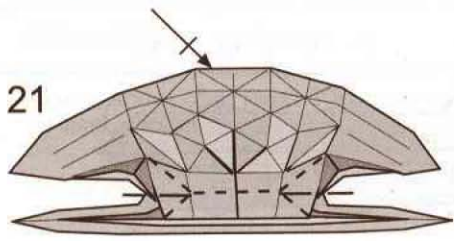

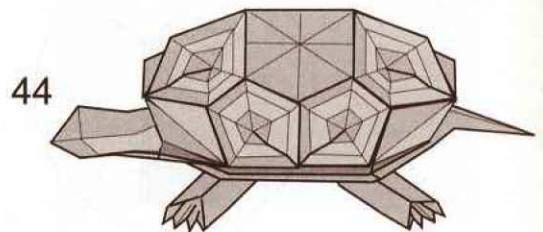
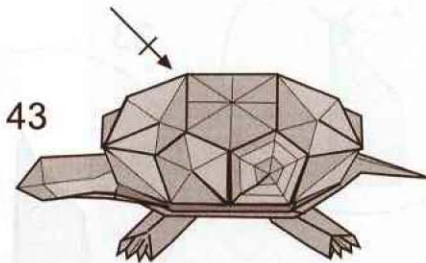
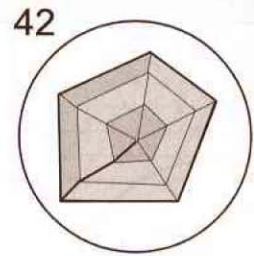
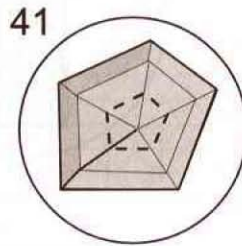
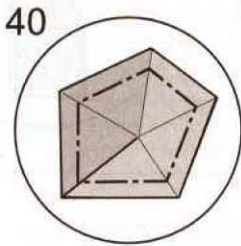
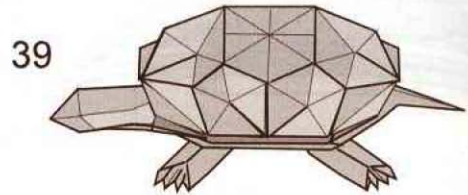
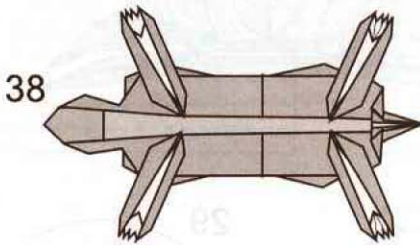
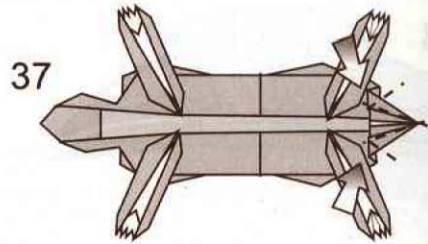
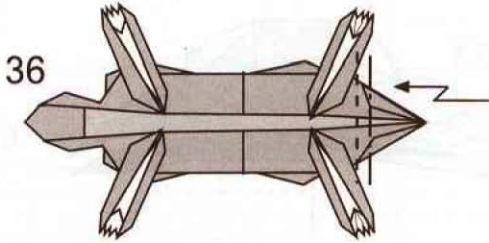
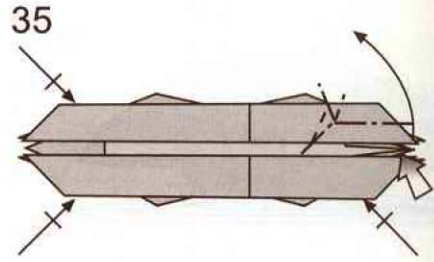
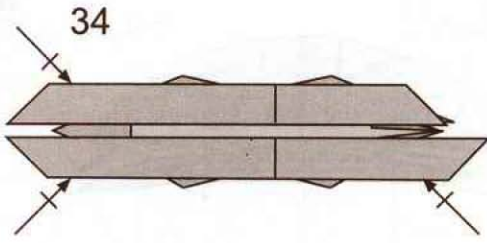

# Giraffe (Version 2)

© Ronald Koh - 2003

Use a sheet of at least 30cm square for a 12cm tall model. Kraft paper of about 70gsm or tissue foil is best.

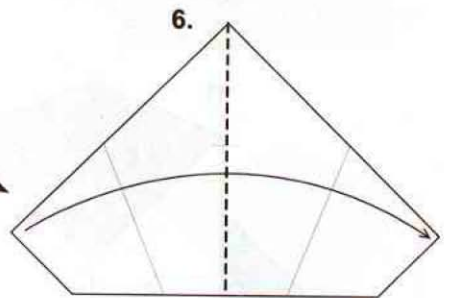
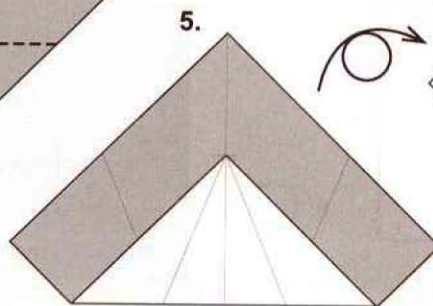
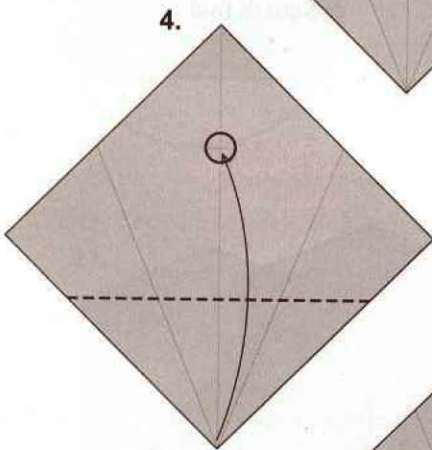
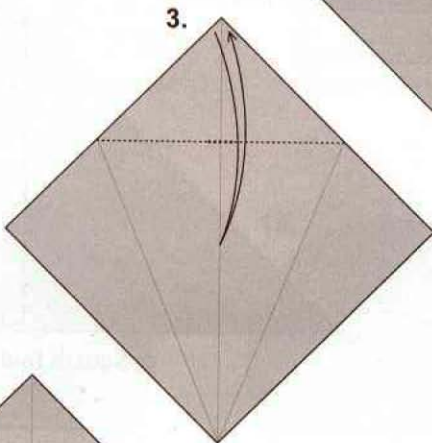
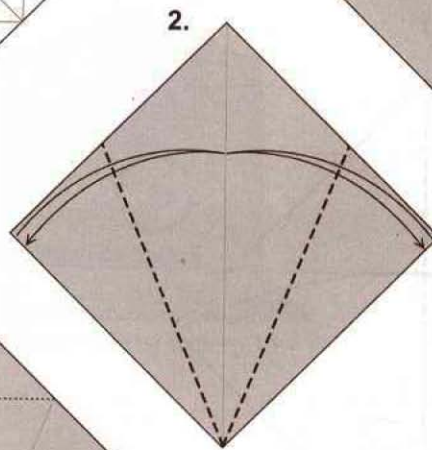
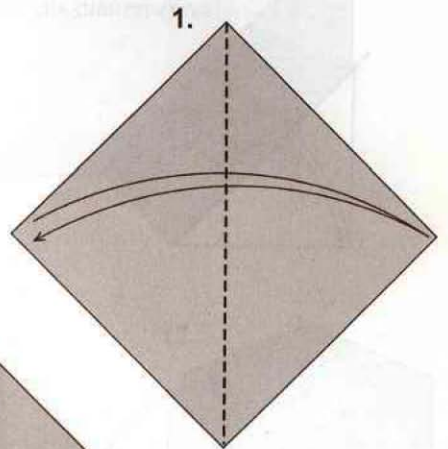
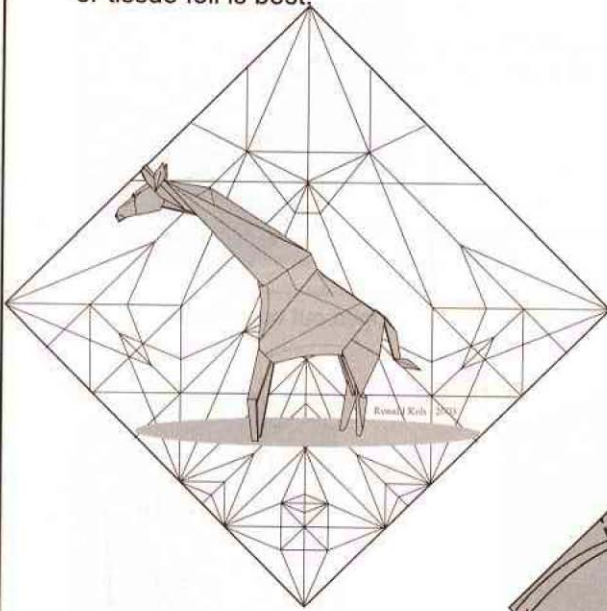

7. Accuracy is very important here. Make sure that the respective layers remain align as you fold.

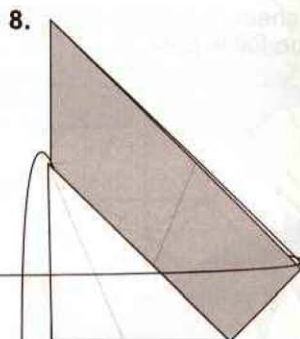
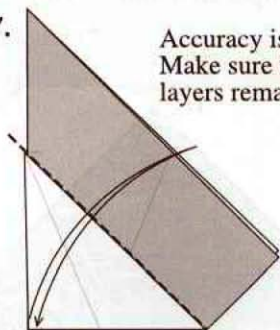

Open out completely.

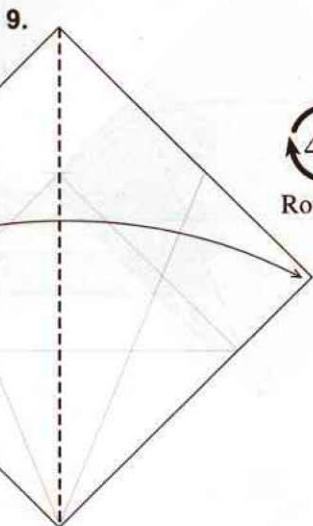

Rotate 45 degrees, clockwise.

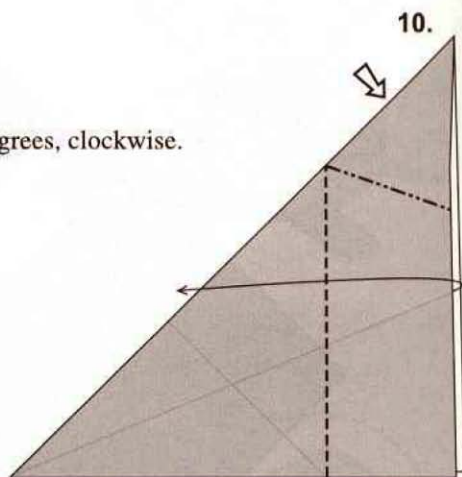

Squash fold

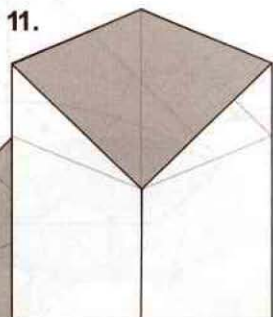

Turn over.

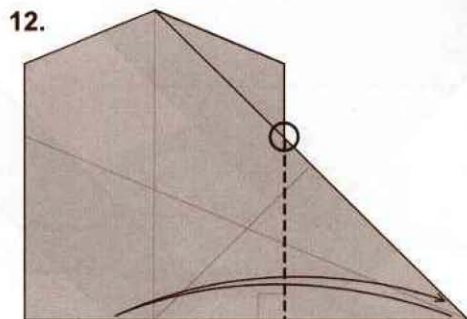



[www.japaoburajirujin.blogspot.com](http://www.japaoburajirujin.blogspot.com)

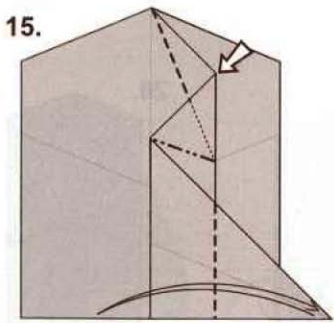
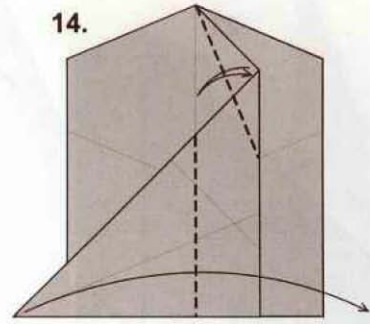
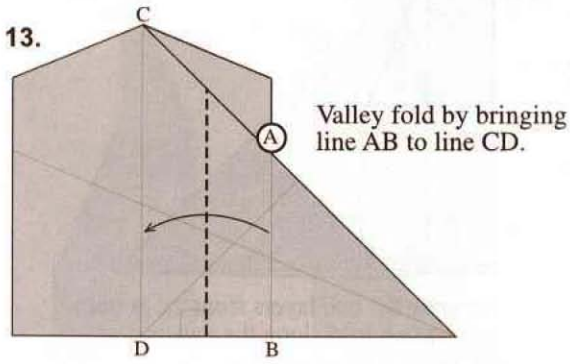

Crimp fold at the top as illustrated.

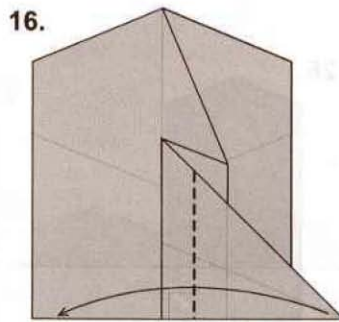

This is similar to Step 13.

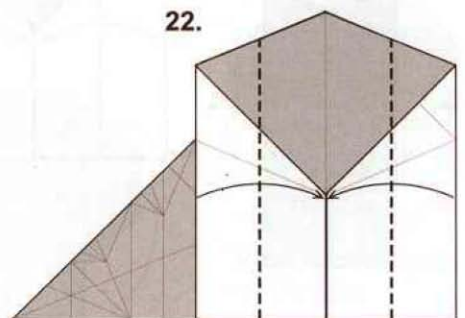
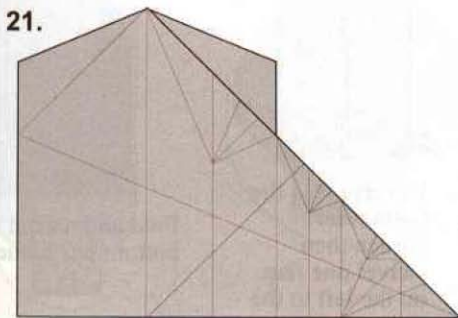
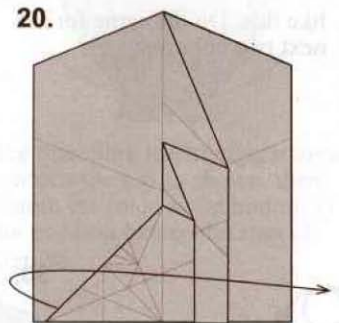
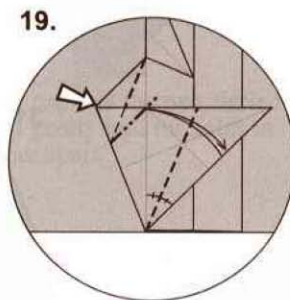
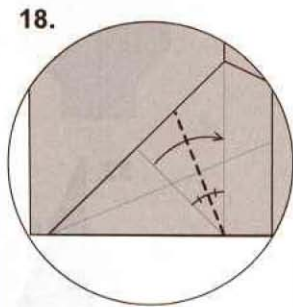
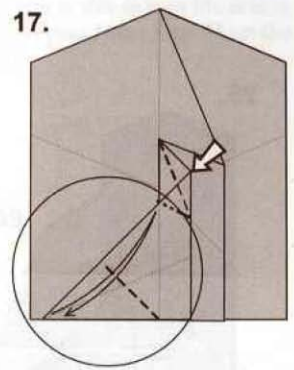

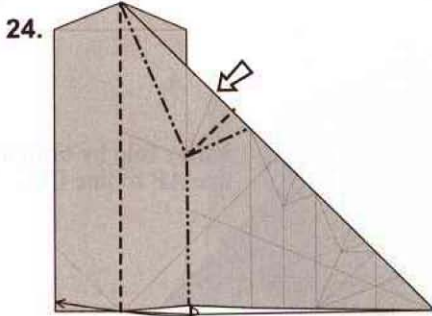
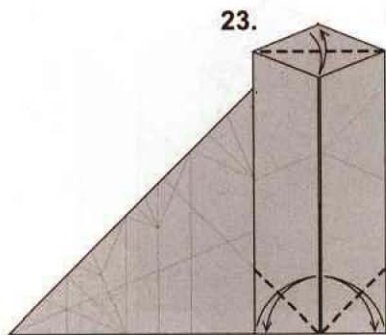

Separate the two layers from the bottom and squash fold along the existing creases lines as shown, ...

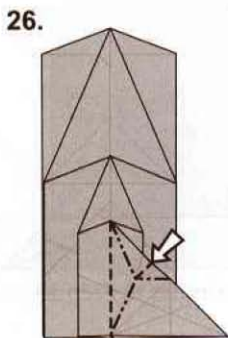
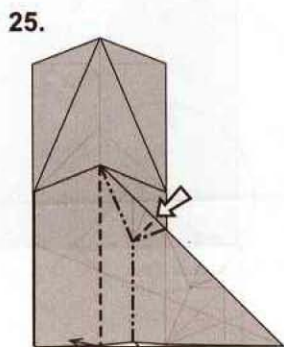

... and so on.

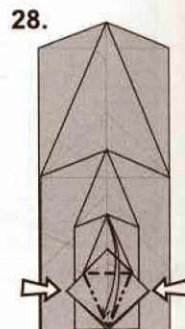
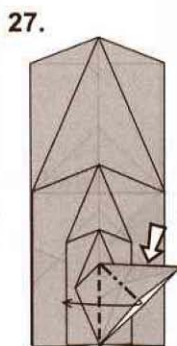

... like this. Do the same for the next two columns, ...

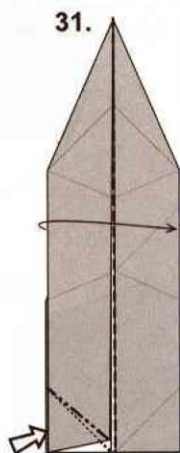
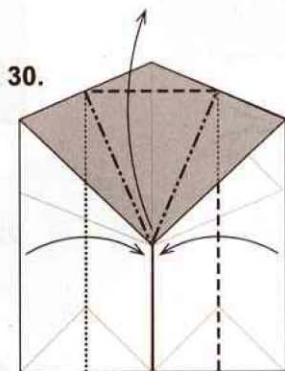
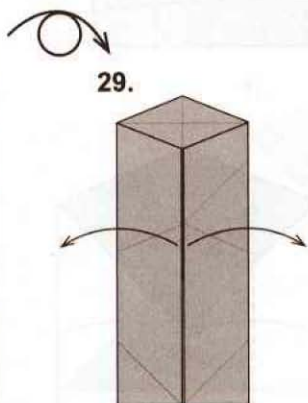

Reverse fold the bottom left corner, then swivel one flap on the left to the right.

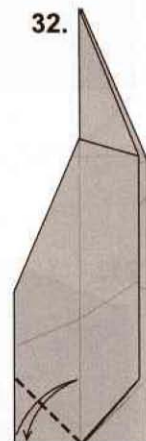

Fold and unfold the bottom left corner, ...

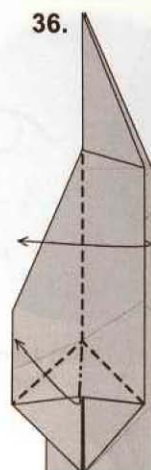
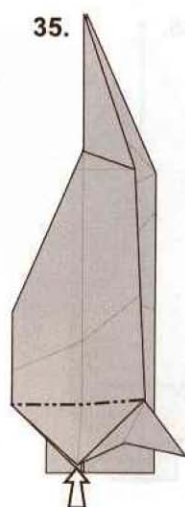
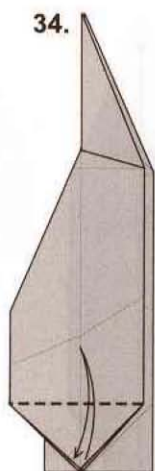
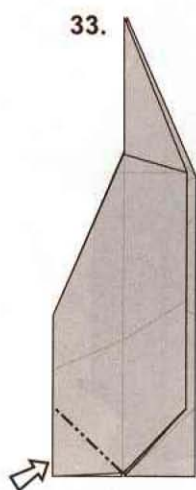

Complete this side as illustrated, then repeat from Step 31 on the right.

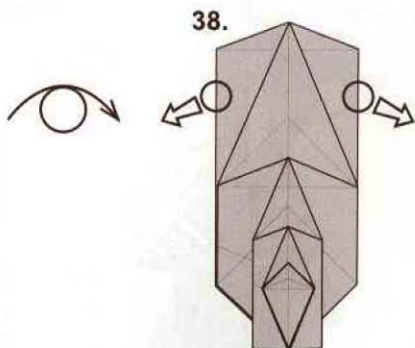
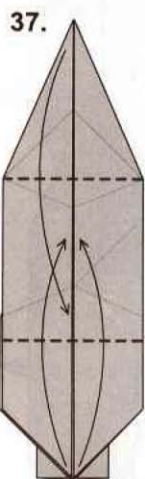

Grasp the paper at the two circled areas and gently pull the folds at the bottom apart, ...

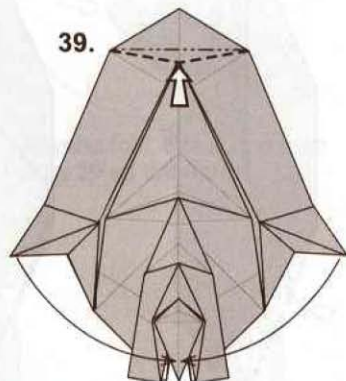

... like this. Sink the triangular area towards the top as shown, then restore the folds at the bottom to the position before the start of Step 38.

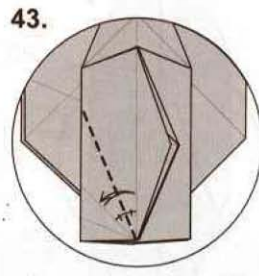
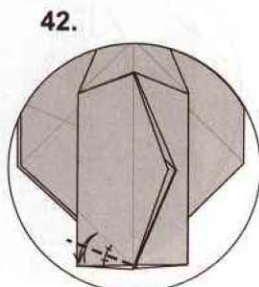
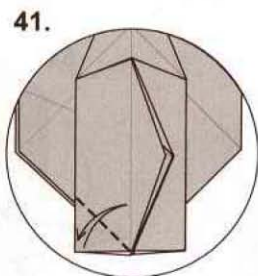

Repeat from Step 40 on the right

44.

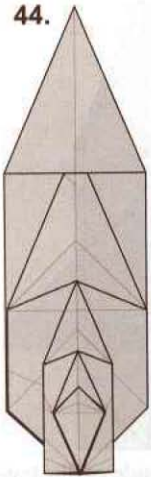

45.



46.



47.

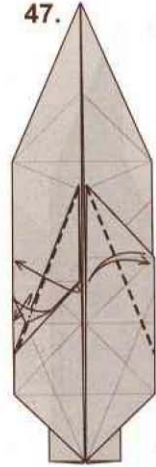

Note the little pocket on the left. Unfold and repeat from Step 46 on the right.

48.

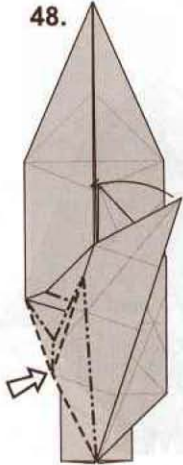

Open sink.

49.

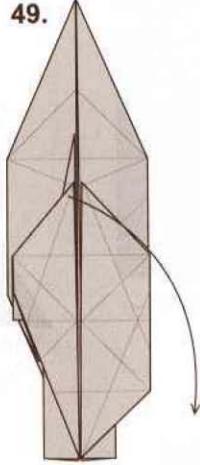

50.

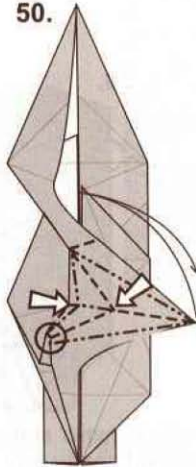

Open sink again. Watch the layers at the circled corners. Fold this point up to flatten the layers, then open up again, ...

51.

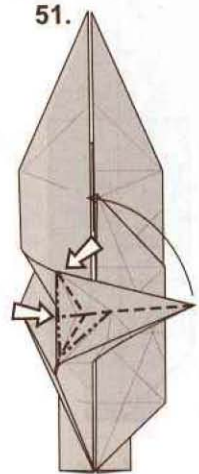

... to reposition the layers as shown, before flatten again.

52.

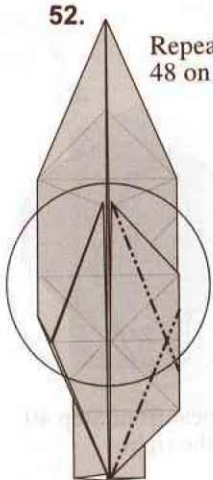

Repeat from Step 48 on the right.

53.

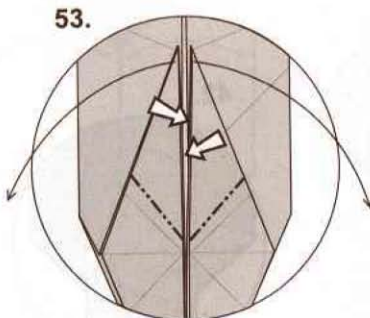

Reverse fold.

54.

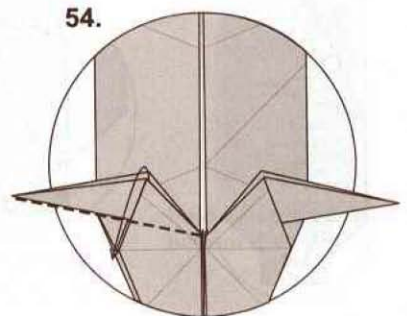

55.

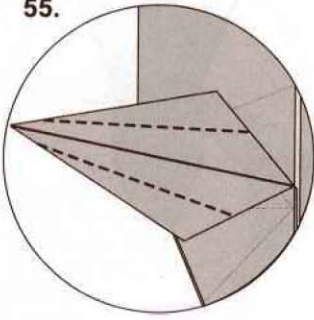

56.

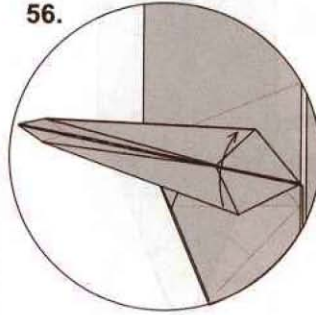

57.

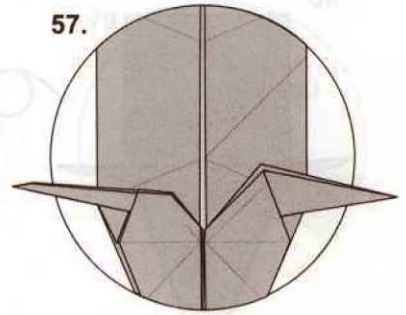

Repeat from Step 55 on the right.

58.

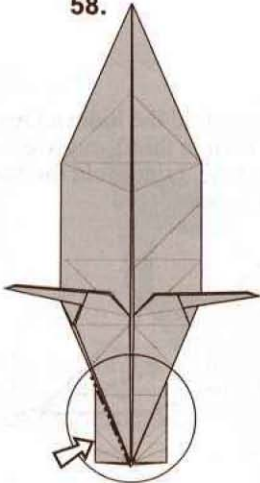

59.

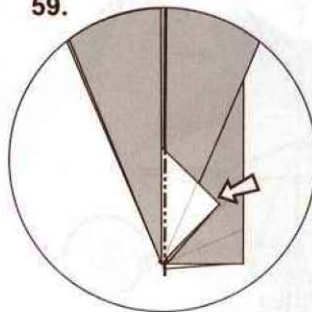

60.

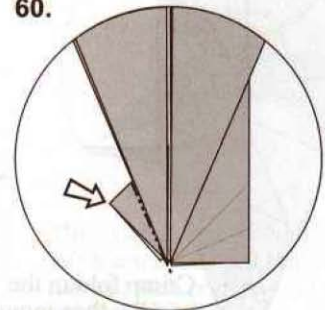

Reverse fold, then repeat from Step 59 on the right.

61.

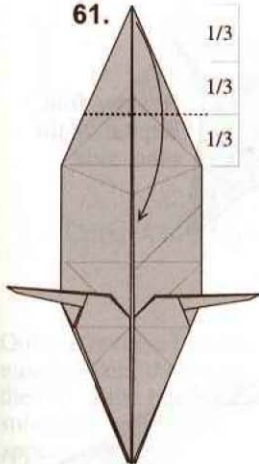

62.

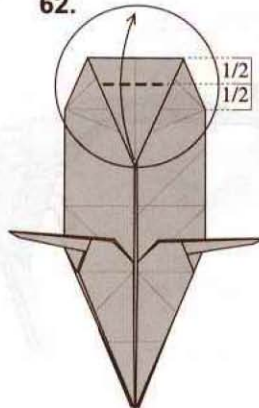

63.

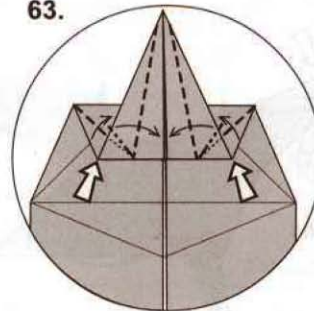

64.

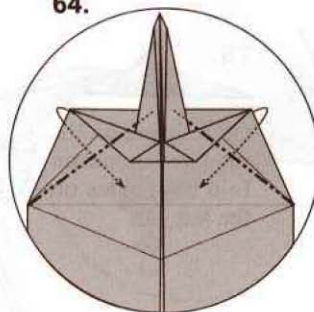

65.

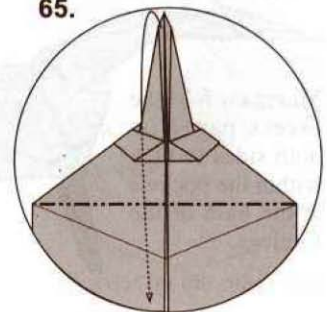

66.

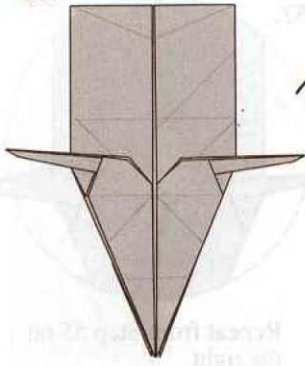

67.

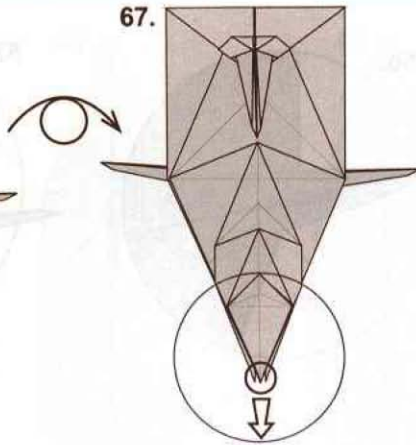

68.

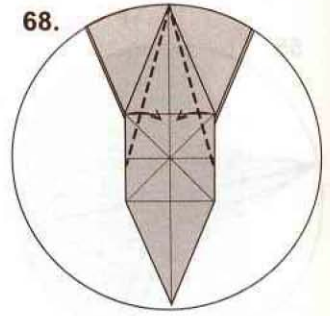

69.

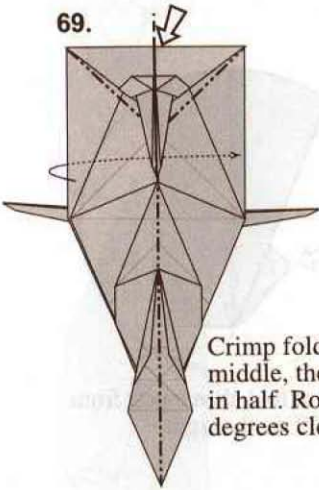

Crimp fold in the middle, then mountain in half. Rotate 90 degrees clockwise.

70.

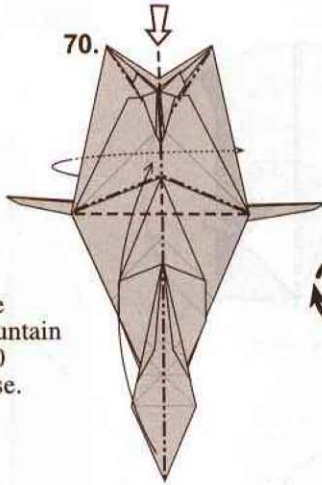

71.

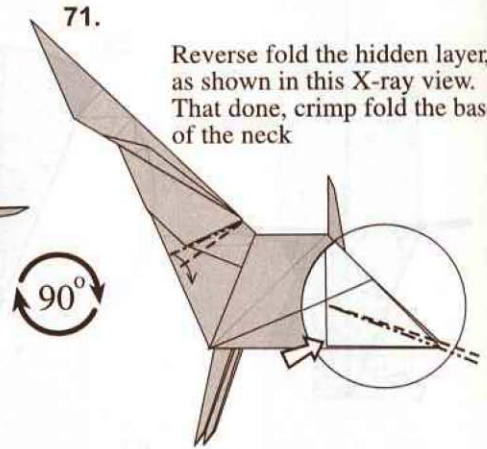

Reverse fold the hidden layer, as shown in this X-ray view. That done, crimp fold the base of the neck

72.

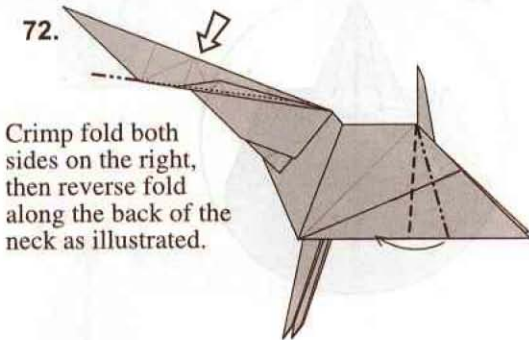

Crimp fold both sides on the right, then reverse fold along the back of the neck as illustrated.

73.

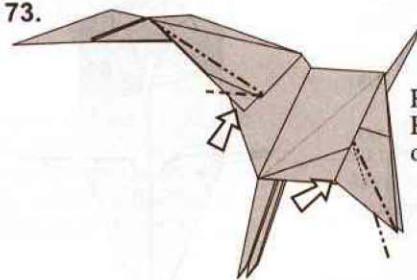

Reverse fold. Repeat on the other side.

74.

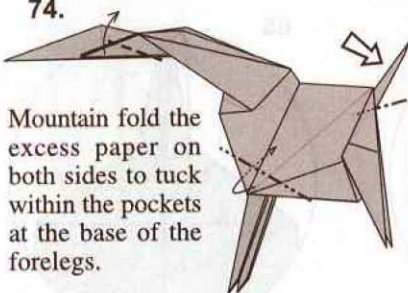

Mountain fold the excess paper on both sides to tuck within the pockets at the base of the forelegs.

75.

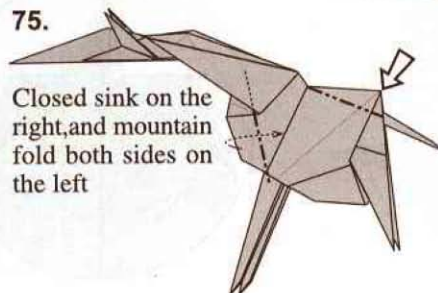

Closed sink on the right, and mountain fold both sides on the left

76.

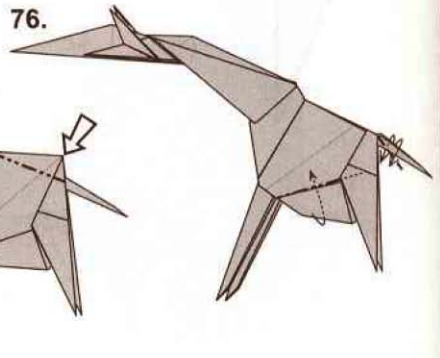



Mountain fold. This should help to keep the layers along the neck together. Repeat on the other side.

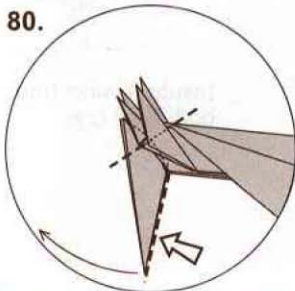
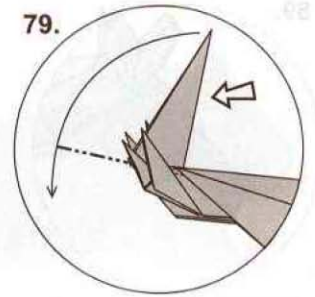
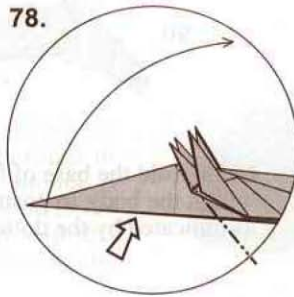

Fold the corners on both sides of the head down, and reverse fold the head piece, ...

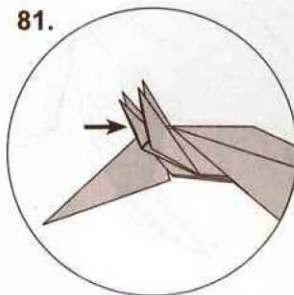

We will now work on the horns, which are the short points sandwiched between the ears.

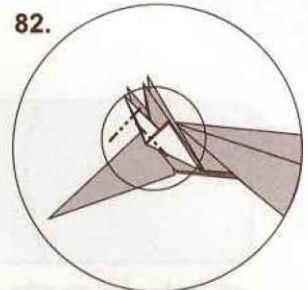

This is an X-ray view of the left horn. Mountain fold to narrow, then reverse fold the tip. Repeat behind.

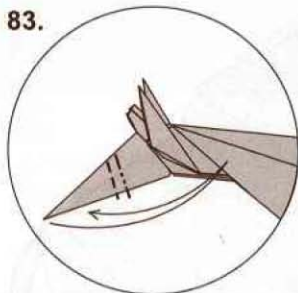

Crimp fold as shown.

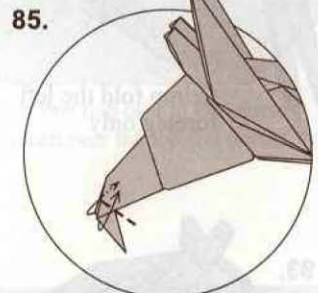
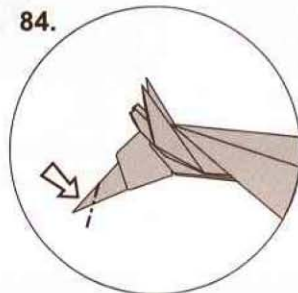

Outside reverse fold.

Outside reverse fold the mouth again, then flatten the top of the head and snout to give it a 3D appearance.

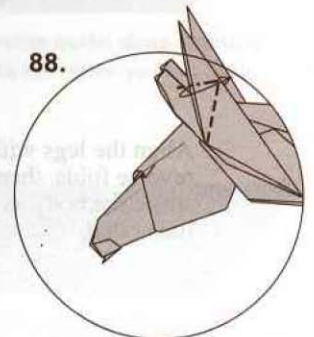
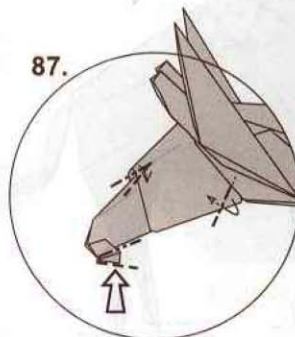
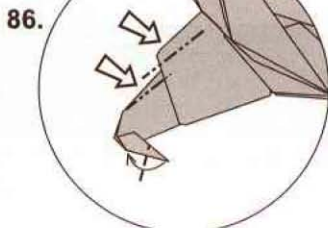

Repeat on the other side

89.

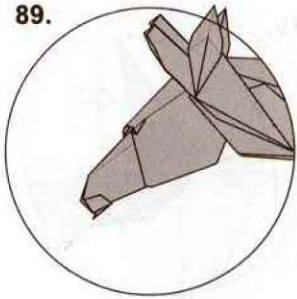

Head done!

90.

Crimp fold the base of the forelegs, within the body, to position the legs as indicated by the dotted lines.

Outside reverse fold the tail

91

Inside reverse fold both hind legs

92.

Crimp fold the left foreleg only.

93.

Align the legs with reverse folds, then shape the body as illustrated.

Ronald Krib - 2003



# Lion

Designed by Robert J. Lang  
Copyright ©1999. All rights reserved.

[www.japaoburajirujin.blogspot.com](http://www.japaoburajirujin.blogspot.com)

This model is designed to be folded from an untrimmed 3x4 rectangle. Since the proportions of untrimmed rectangles may vary, this model is relatively forgiving of small variations in the initial folding proportions. If you plan to wet-fold this model, fold the paper dry up to step 20, then unfold, dampen, refold, and continue.

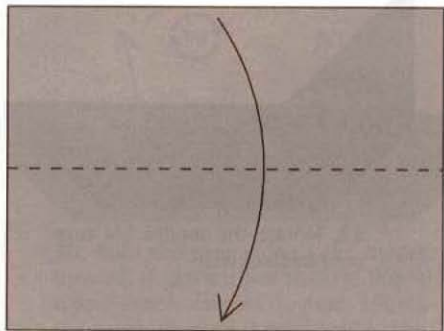
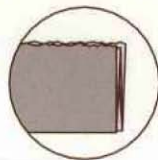
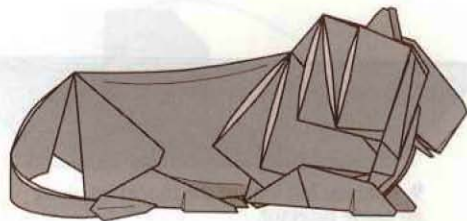

1. Begin with the colored side up. Fold the paper in half from top to bottom.

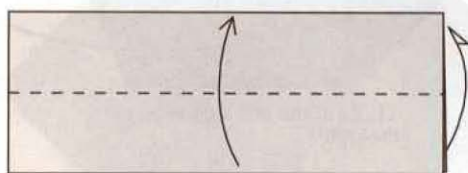

2. Fold the bottom edge up to lie along the top edge. Repeat on the far side. If the edge is rough, it should overlap the top edge slightly as shown in the inset.

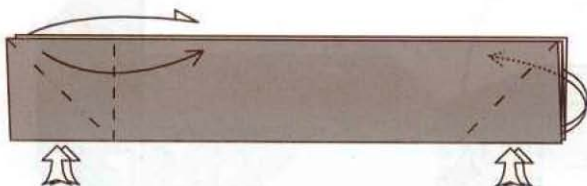

3. Squash-fold the lower left corner; repeat behind. Reverse-fold the lower right corner; repeat behind.



4. Fold the tip of one flap over to the crease; make a small pinch near the top and unfold.



5. Fold the tip of the flap over to the crease you just made; make a small pinch near the top and unfold.



6. Crease through the entire model along a vertical crease that lines up with the crease you just made.



7. Fold a rabbit ear from the near flap. Repeat behind.

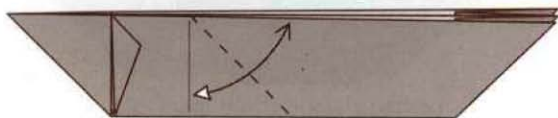

8. Crease lightly along the angle bisector.

[www.japaoburajirujin.blogspot.com](http://www.japaoburajirujin.blogspot.com)

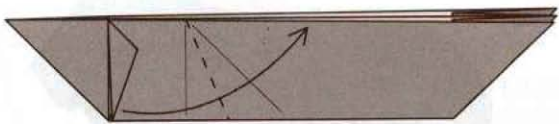

9. Fold the left side of the model up along an angle bisector.

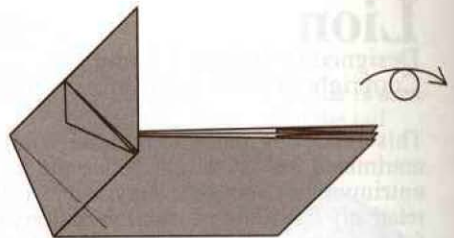

10. Turn the model over from side to side.

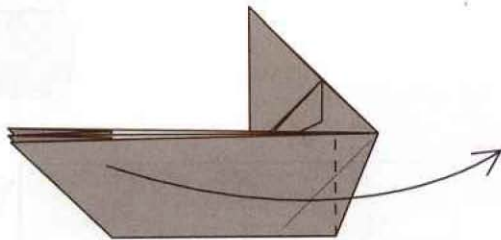

11. Fold the left side over to the right.

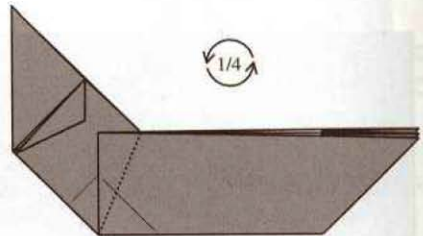

12. Rotate the model 1/4 turn counterclockwise.

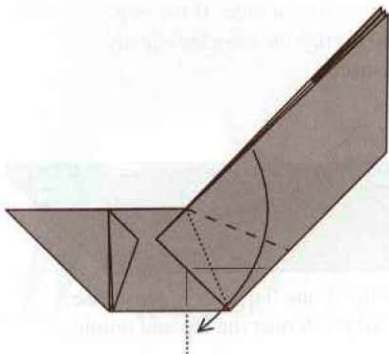

13. Fold the flap back downward so that its edge lines up with the existing vertical crease.

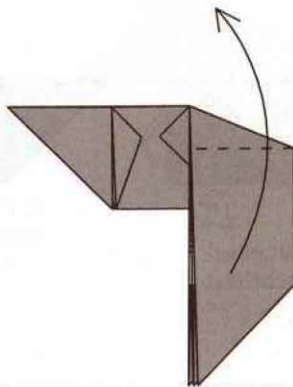

14. Fold the flap back up so that its left edge is vertical.

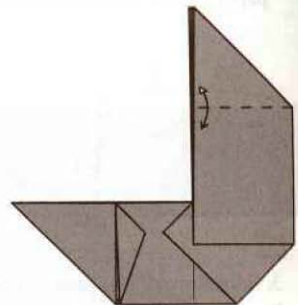

15. Crease lightly through a single layer. Repeat behind.

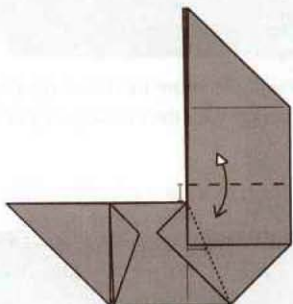

16. Fold and unfold. The exact position of the crease isn't critical, but you can use the distance marked "d" as a guide.

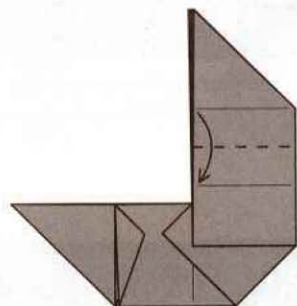

17. Fold the flap down so that the pinch from step 15 lines up with the crease you just made.

[www.japaoburajirujin.blogspot.com](http://www.japaoburajirujin.blogspot.com)

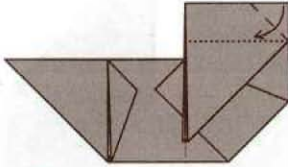

18. Fold the thick corner down so that its edge lies along a horizontal line.

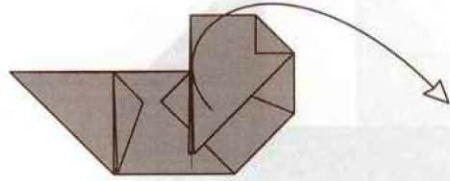

19. Unfold to step 9.

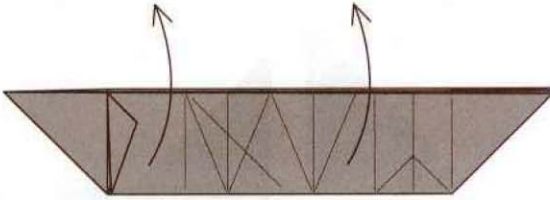

20. Fold the near side of the model upward. If you are wet-folding, this is a good time to dampen the paper. Unfold the paper, dampen it completely, then refold to this step.

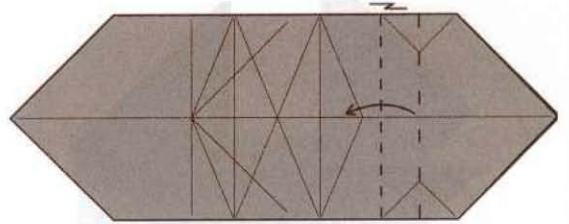

21. Pleat the paper on the existing creases.

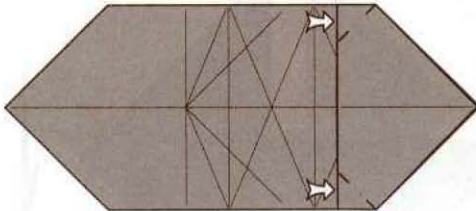

22. Reverse-fold the corners.

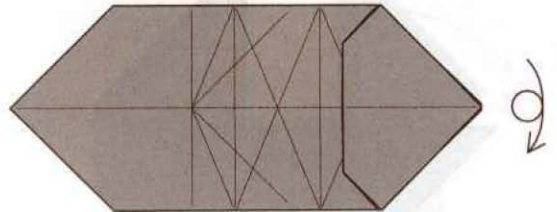

23. Turn over the model from top to bottom.

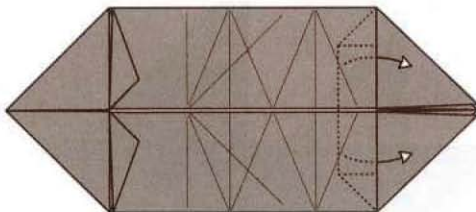

24. Pull out the loose paper.

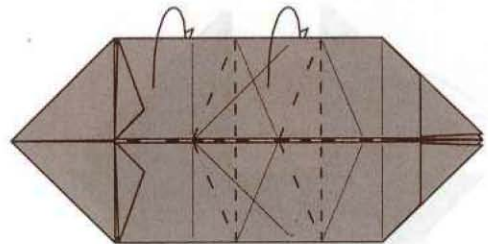

25. Fold the model in half, incorporating the two pleats on the existing creases.

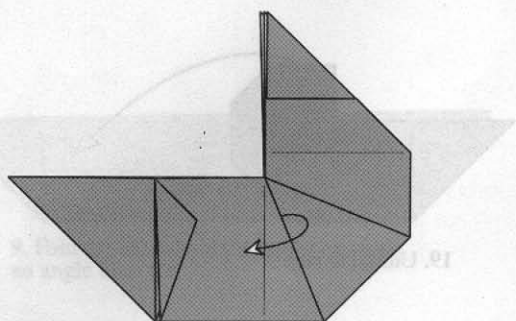

26. Pull out some loose paper. Repeat

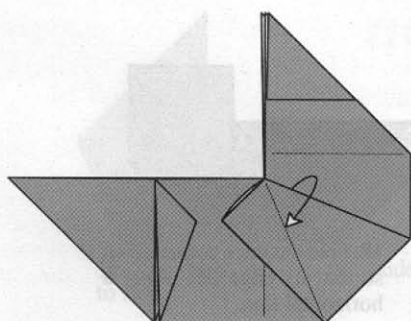

27. Pull out some more loose paper. Repeat behind.

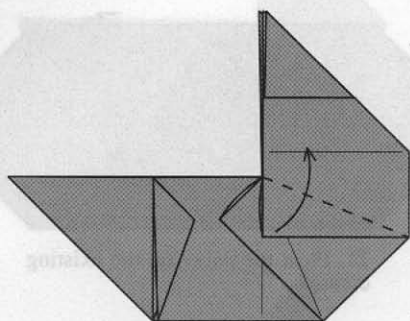

28. Fold one flap up as far as possible. Repeat behind.

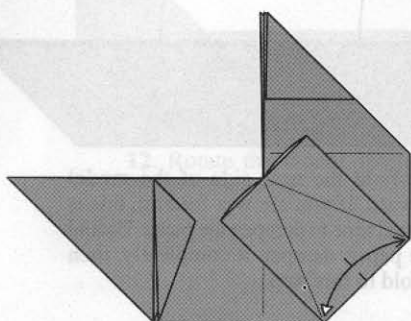

29. Fold and unfold.

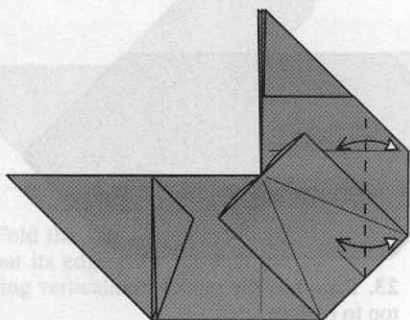

30. Fold and unfold. Repeat behind.

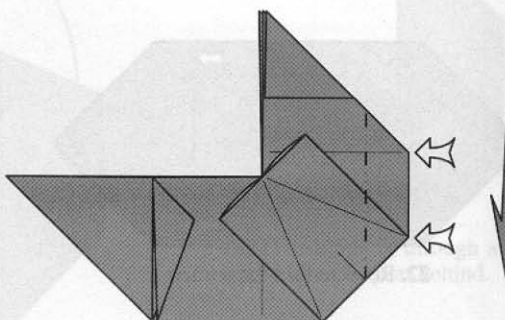

31. Sink the edge. The sink is partially open, partially closed. The edge view shows where the open parts are. Repeat behind.

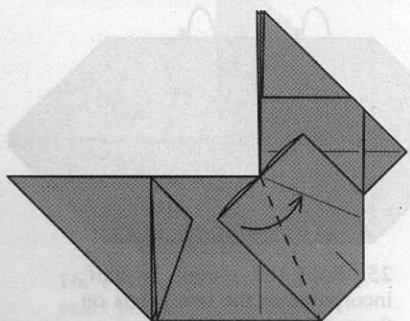

32. Fold one flap upward. Repeat behind.

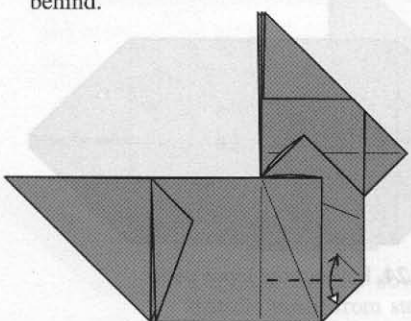

33. Fold and unfold. Repeat behind.

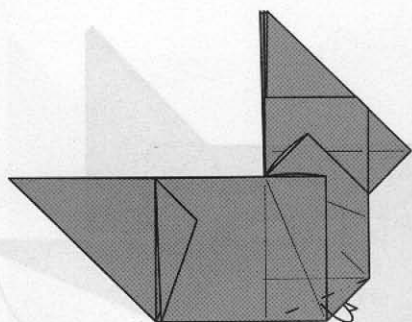

34. Mountain-fold the corner underneath. Repeat behind.

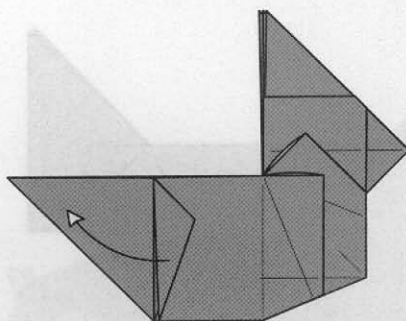

35. Unfold the flap. Repeat behind.

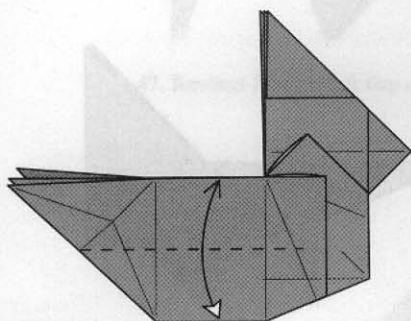

36. Fold the bottom edge up to the top; crease firmly and unfold. Repeat behind.

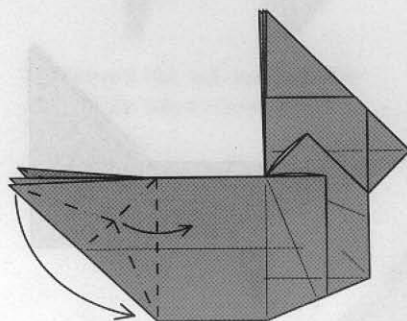

37. Refold the left flap. Repeat behind.

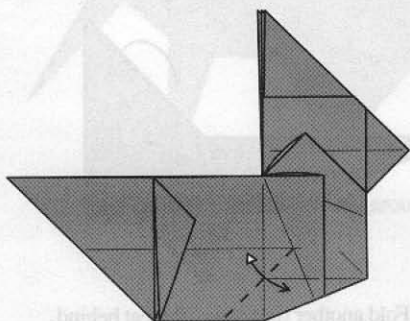

36. Fold and unfold. The crease runs through two crease intersections and is at 45°. Repeat behind.

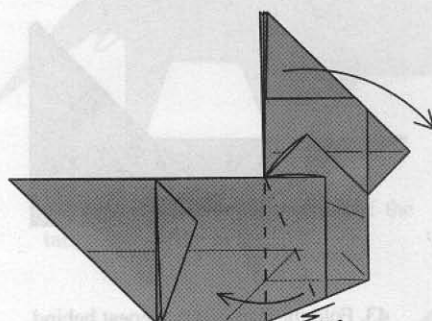

37. Crimp on the existing creases. The top of the model swings over to the right. Flatten firmly.

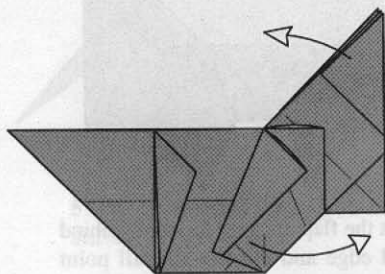

38. Unfold to step 37.

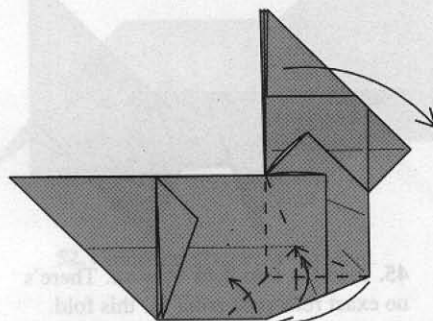

39. Redo the crimp, but incorporating the creases shown, both front and behind.

[www.japaoburajirujin.blogspot.com](http://www.japaoburajirujin.blogspot.com)

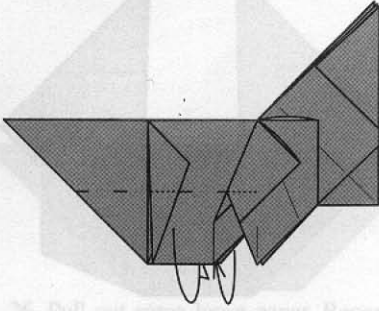

39. Mountain-fold the edges underneath on the existing creases.

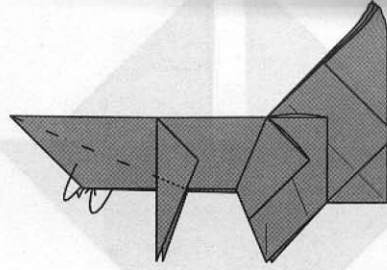

40. Mountain-fold the edges underneath.

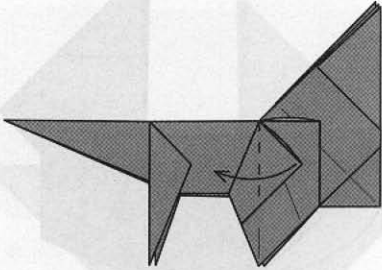

41. Valley-fold the flap to the left. Repeat

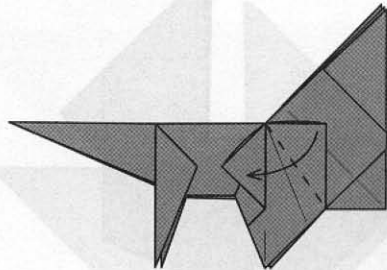

42. Fold the next flap down. Repeat

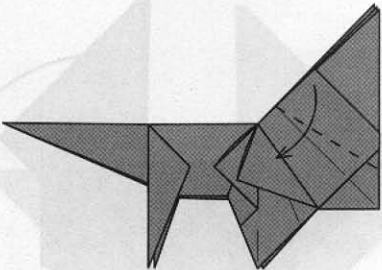

43. Fold the flap down. Repeat behind.

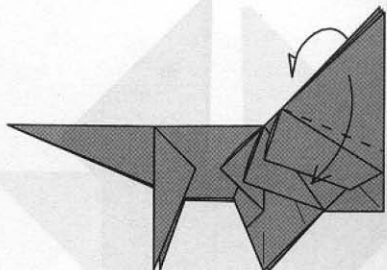

44. Fold another flap down. Repeat behind.

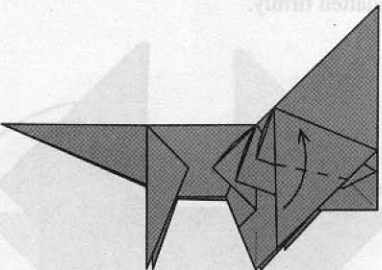

45. Fold the flap back upward. There's no exact reference point for this fold.

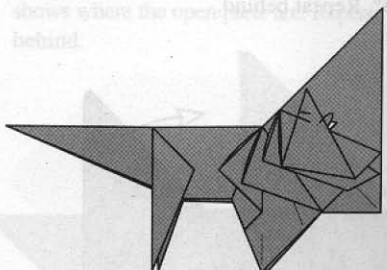

46. Pleat the flap, tucking the pleat behind a folded edge and leaving a small point poking up. Repeat behind.

[www.japaoburajirujin.blogspot.com](http://www.japaoburajirujin.blogspot.com)

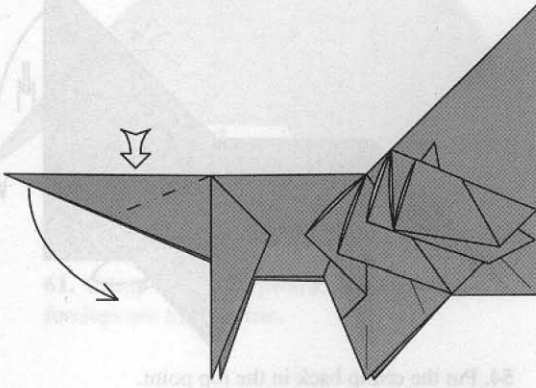

47. Reverse-fold the left flap downward.

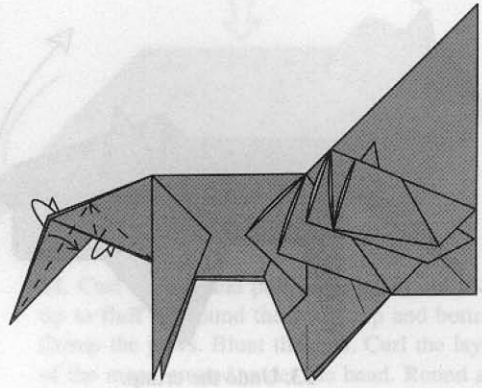

48. Narrow the tail and tuck the edges inside where it joins the body.

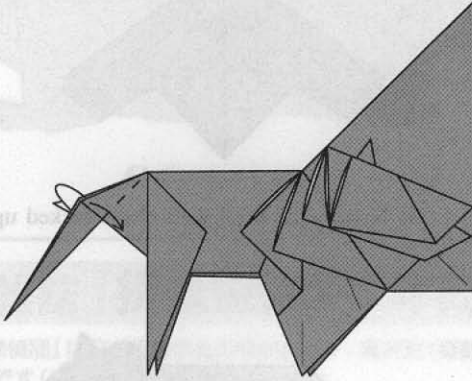

49. Wrap the edges of the tail around.

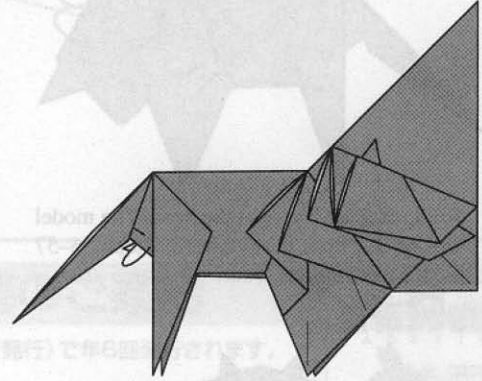

50. Tuck the edges at the base of the tail up inside the model.

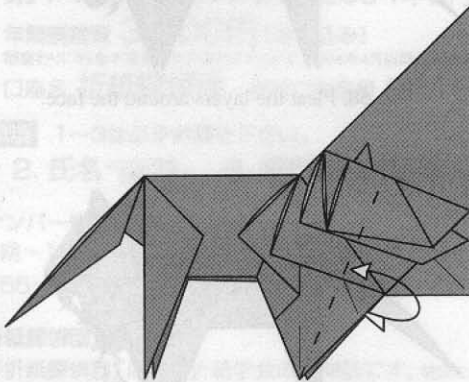

51. Mountain-fold through all layers and unfold. Repeat behind.

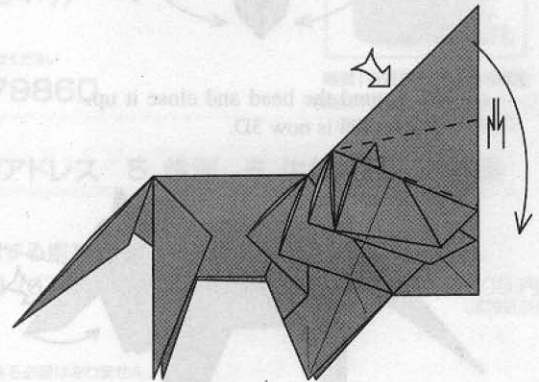

52. Crimp the top point downward.

[www.japoburajirujin.blogspot.com](http://www.japoburajirujin.blogspot.com)

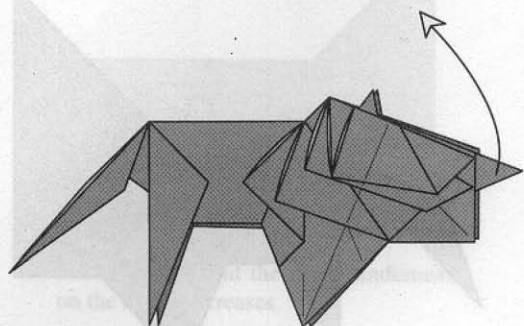

53. Undo the crimp.

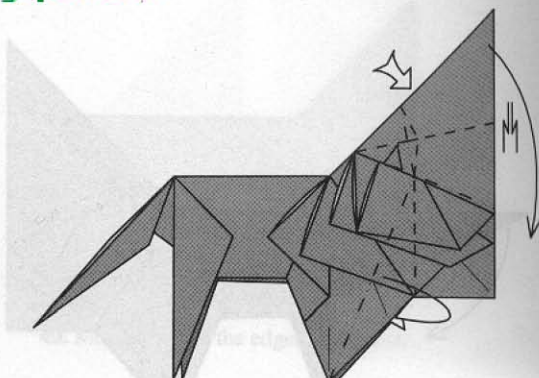

54. Put the crimp back in the top point, but at the same time pleat the forelegs and add some creases to the top crimp.

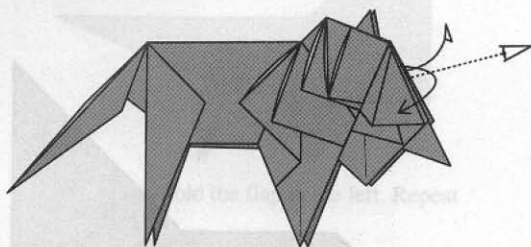

55. Spread the layers of the head. The model will be 3D from here onward. Steps 56–57 are a view from the front.

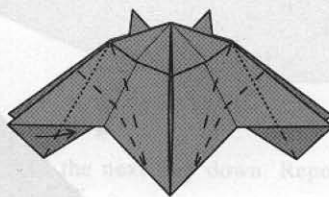

56. Narrow the head with pleats tucked up

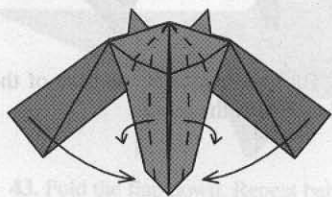

57. Round the head and close it up. The model is now 3D.

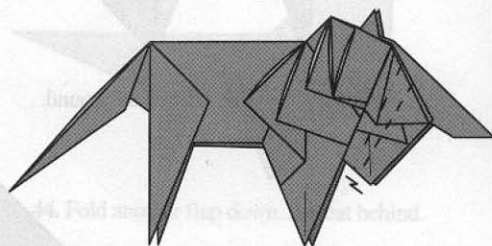

58. Pleat the layers around the face.

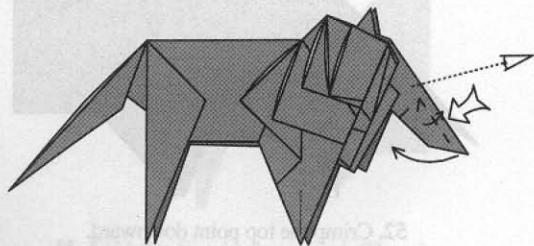

59. Squash-fold the nose downward and wrap the edges around the front of the face.

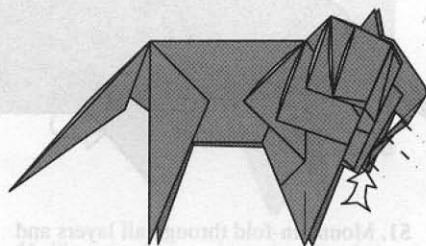

60. Sink the corner of the flap. Fold it back and forth to make a lower jaw.



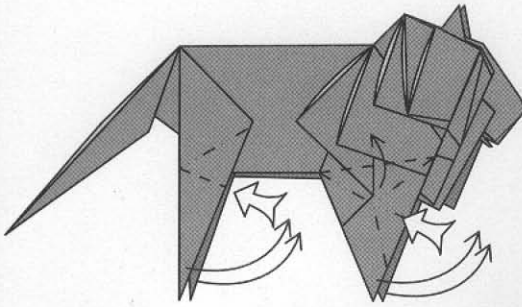

61. Crimp the feet upward. Note that the forelegs are asymmetric.

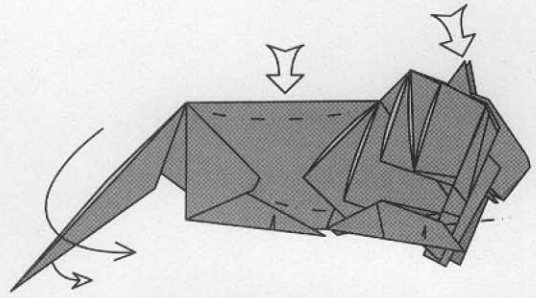

62. Curl the tail and pull some paper out of its tip to fluff it. Round the body, top and bottom. Crimp the paws. Blunt the ears. Curl the layers of the mane around under the head. Round and shape the entire body.

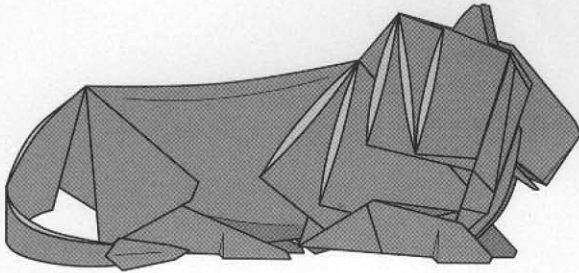

63. Finished Lion.

## 雑誌「折紙探偵団」年間購読のご案内

雑誌「折紙探偵団」は日本折紙学会の機関誌です。隔月刊(奇数月 25 日発行)で年6回発行されます。年間購読制です(ばら売りは行っておりません)。

- 申込方法** 1. 郵便振替にてご送金下さい(普通の振替用紙でお申込み頂けます)。  
2. 振替用紙の「通信欄」に下記必要事項をご記入下さい。

第14期(2003年4月~2004年3月/79~84号)

年間購読費 3,600円(送料込み)

期変わりに料金が変わる場合があります。2004年4月以降は事務局にお問い合わせください

口座名 折紙探偵団 振替口座番号 00180-8-579860

**記入必要事項** 1~3は必ずお書き下さい。

1. 住所 2. 氏名 ※ふりがなをお願いします。 3. 電話、FAX番号 4. E-Mailアドレス 5. 性別 6. 生年月日 7. 職業

### ■バックナンバー購入について

現在10期~13期を取り扱っております。「通信欄」のところへ希望する期を明記の上、相当金額をお振り込み下さい。

10期(55~60号)……3,000円、11期(61~66号)・12期(67~72号)・13期(73~78号)……各3,600円(送料込み)

### ■雑誌「折紙探偵団」について

- ・「折紙探偵団」は日本折紙学会の機関誌です。購読には学会会員である必要はありません。
- ・隔月刊(奇数月 25 日発行)で年6回発行されます。
- ・年間購読のみ受け付けています。ばら売りは行っておりません。
- ・海外発送をご希望の場合は料金が異なります。事務局へお問い合わせください。
- ・折り図・展開図・折り紙研究・エッセイ・最新情報など充実の誌面です。



雑誌「折紙探偵団」79号表紙  
表紙フルカラー/本文38ページ  
(カラー図絵2ページ含む)

日本折紙学会事務局(10:00~18:00 日祝休)〒113-000東京都文京区白山 1-33-8-216  
Phone/Fax 03-5684-6080 日本折紙学会ホームページ <http://www.origami.gr.jp/>

# Japão Burajirujin

[www.japaoburajirujin.blogspot.com](http://www.japaoburajirujin.blogspot.com)

41. Crimp the paper out of the top to fluff the head, top and bottom. Crimp the paper. Fluff the ears. Round and shape the entire body.

42. Put the crimp paper in the top point, but at the same time pleat the forelegs and the back to give it the top crimp.

43. Finished lion.

## 第9回 折紙探偵団 コンベンション折り図集

PRINTED IN JAPAN

2003年8月23日発行

著者／日本折紙学会

発行人／西川誠司

編集人／山口 真

編集スタッフ／松浦英子、神谷哲史

デザイン／おりがみはうす

翻訳協力／立石浩一

発売元 おりがみはうす

発行所／日本折紙学会

113-0001

東京都文京区白山 1-33-8-216 (ギャラリーおりがみはうす内)

Phone & Fax 03-5684-6080 (10:00~18:00/日・祭日休)

E-mail= [webman@origami.gr.jp](mailto:webman@origami.gr.jp)

Web Site = <http://www.origami.gr.jp/>

■OrigamiTanteidan Convention Book vol.9 / Published on 23, August, 2003 by Japan Origami Academic Society, 1-33-8-216 Hakusan Bunkyo-ku 113-0001 Tokyo JAPAN / Publisher : Nishikawa Seiji / Editor in Chief : Yamaguchi Makoto / Editorial Design : OrigamiHouse / Translation Adviser : Tateishi Koichi

本書の内容の無断転載・複製頒布を禁す

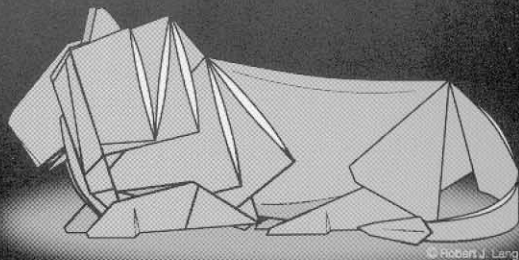

© Robert J. Lang

# Japão Burajirujin

[www.japaoburajirujin.blogspot.com](http://www.japaoburajirujin.blogspot.com)

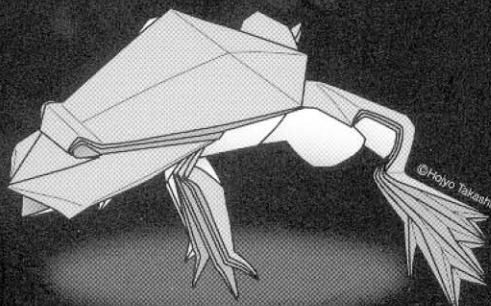

© Hoyo Takashi

9th CONVENTION 2003

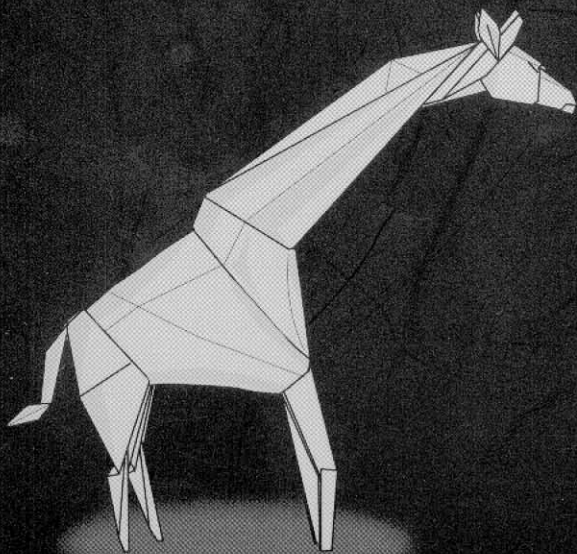

© Ronald Koh 2003

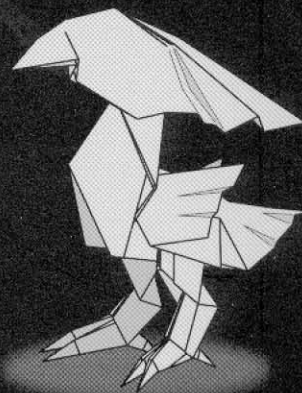

© Kamiya Satoshi

定価 2,000円