

ORIGAMI TANTEIDAN 12th CONVENTION

第12回
折紙探偵団
コンベンション

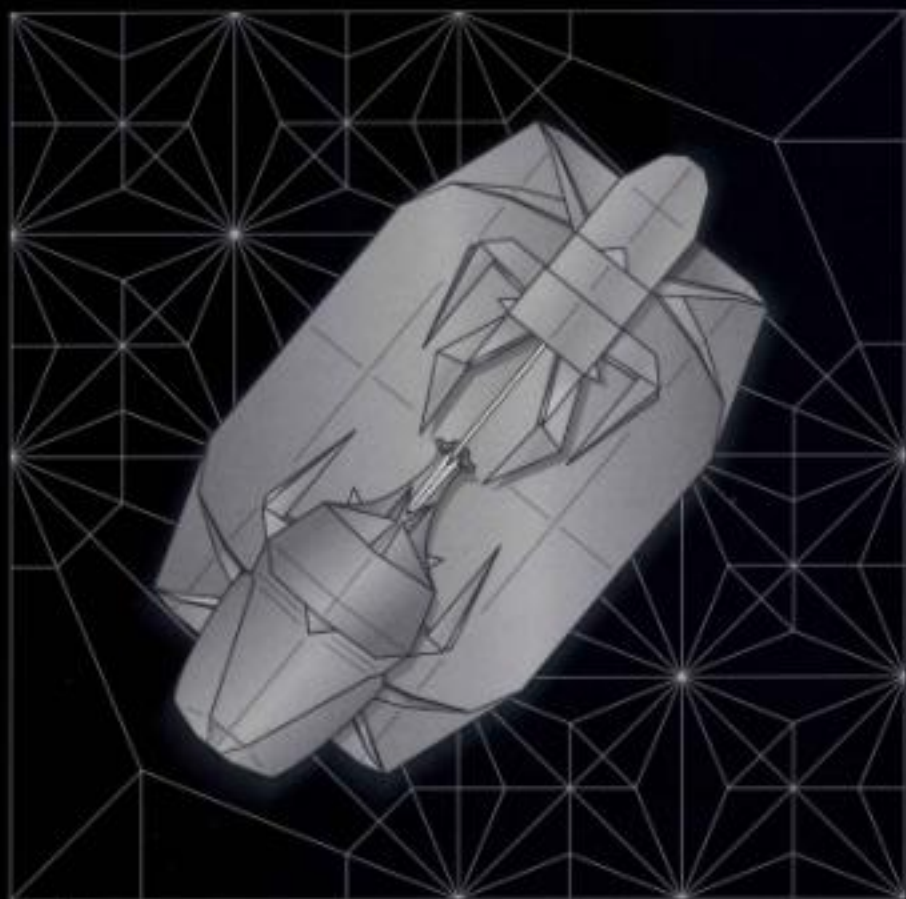

© Hagen Tokuda

折り図集

.....
Vol.12

発行・日本折紙学会

第12回

折紙探偵団コンベンション折り図集

12th Origami Tanteidan Convention Book

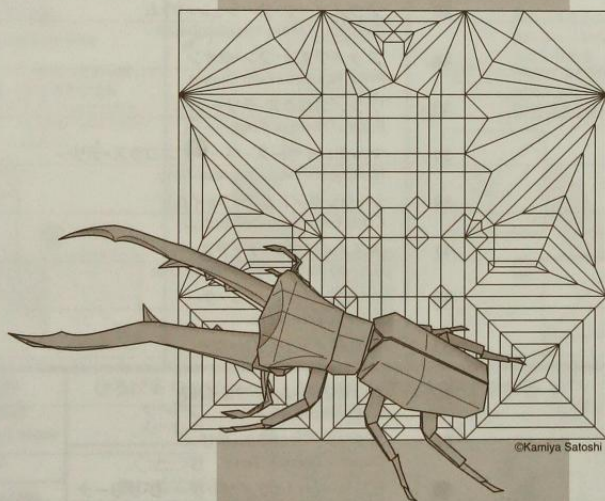

©Kamiya Satoshi

Vol.12

発行・日本折紙学会

12th Origami Tanteidan Convention Book

折り図記号 Symbols for Folding	3	折りたたみ椅子 / 津田良夫 Camp chair / Tsuda Yoshio	87
基本形・沈め折り Preliminary Bases and Sink	4	オリガミビルダー2・鉄橋 / 木下一郎 ORIGAMI BUILDER NO.2, Bridge / Kinoshita Ichiro	90
国内編 : Models by Japanese Folders			
ペンギンくん(ちび) / 木村良寿 Penguin-Kun, Chick / Kimura Yoshihisa	6	クラスタ / 田中将司 CLUSTER / Tanaka Masashi	98
海亀 / 宮本真理子 Sea Turtle / Miyamoto Mariko	7	3つの6枚組みユニット / 川畑文昭 Three-units of 6-pieces / Kawahata Fumiaki	101
イルカ / 宮本真太郎 Dolphin / Miyamoto Shintaro	8	吉本キューブ / 川島英明 YOSHIMOTO'S CUBE / Kawashima Hideaki	104
イルカ / 青木 良 Dolphin / Aoki Ryo	8	ステラ・コニカ(ニードルズ) / 川村みゆき STELLA CONICA (NEEDLES) / Kawamura Miyuki	106
カブトガニ / 青木 良 Horseshoe Crab / Aoki Ryo	15	15°ショウリョウバッタ / 西川誠司 Longheaded Locust based on 15° / Nishikawa Seiji	109
メコンオオナマズ / 水野 健 Mekong Giant Catfish / Mizuno Ken	18	メタルフェルホソアカクワガタ 2.0 / 神谷哲史 Cyclommetalifer 2.0 / Kamiya Satoshi	114
ネズミ式 / 水野 健 Mouse 2 / Mizuno Ken	20	カタツムリ / 目黒俊幸 Snail / Meguro Toshiyuki	128
うさぎ / 藤倉敦夫 Rabbit / Fujikura Atsuo	22	決戦!!カブト対クワガタ / 北條高史 Samurai Helmet Beetle vs. Stag Beetle / Hojyo Takashi	141
ねねこ(いねむりねこ) / 木村良寿 Napping Cat / Kimura Yoshihisa	25	海外編 : Models by Foreign Folders	
ころねこ(おすわりねこ) / 木村良寿 Sitting Cat / Kimura Yoshihisa	26	ライオン / チェン・チット・レオン Lion / Cheng Chit Leong	160
でぶねこ / 木村良寿 Tubby Cat / Kimura Yoshihisa	28	ゾウ / マーク・カーシェンバウム Elephant / Marc Kirschenbaum	164
白足袋猫・ブルテリア / 前川 淳 White Socks, Bull Terrier / Maekawa Jun	30	ブタ / グエン・フンクオン PIG / Nguyen Hung Cuong	170
仔犬 / 勝田恭平 Puppy / Katsuta Kyohei	34	ワシ / ニcolas・テリー Eagle / Nicolas Terry	173
ダックスフント / 青木 良 Dachshund / Aoki Ryo	38	マルチレイヤーズ・バード / ニcolas・テリー Multilayers Bird / Nicolas Terry	176
コリー / 渡辺 大 Collie / Watanabe Dai	41	シャクシギ / トム・デフォイルト CURLEW / Tom Defoirdt	182
セントバーナード / 霞 誠志 Saint Bernard / Kasumi Seishi	48	スズメ / ロマン・ディアス Gorion (Sparrow) / Roman Diaz	183
フライング・ピッグ / 永田創平 Flying Pig / Nagata Sohei	53	ペリカン / ジェイソン・クー Pelican / Jason Ku	192
いのしし / 宮島 登 Wild Boar / Miyajima Noboru	60	七面鳥 / ジェイソン・クー Turkey / Jason Ku	197
コウモリ / 川村みゆき Bat / Kawamura Miyuki	66	コウモリ / トム・デフォイルト BAT / Tom Defoirdt	202
マンモス / やまぐち真 Mammoth / Yamaguchi Makoto	68	ゴブリン / ニcolas・テリー Goblin / Nicolas Terry	205
オウム / 猪原龍介 Ohmu / Ihara Ryusuke	71	ビンテージバイク / ザンダー・D・アリーナ Iconic Motorcycle / Xander D. Arena	217
ニケ / 中井 努 The Winged victory of Samothrace / Nakai Tsutomu	74	一枚折りのバラ / ブライアン・チャン One-Sheet Rose / Brian Chan	225
かめはめ波を撃つフードの人 / 舘 知宏 Man in Hood Shooting Kamehameha Wabe / Tachi Tomohiro	79	ミウラ・ケン・ビューティー・ローズ / ロバート・J・ラング A Miura-ken Beauty Rose / Robert J. Lang	230
おほしさま / 木下 剛 Twinkle Star / Kinoshita Go	82	コノハギス / ブライアン・チャン Leaf Katydid / Brian Chan	235
レイ / 市川 学 Lei / Ichikawa Manabu	84	ユウレイヒリアシナナフシ / マヌエル・シルゴ Espectro Macleay (Walking stick-leaf) / Manuel Sirgo	238
		プテラノドン / ジェイソン・クー Pteranodon / Jason Ku	249

折り図記号 Symbols for Folding

折り線の種類 Types of crease lines

谷折り線 Valley fold



谷折り
Valley fold

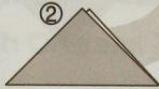

山折り線 Mountain fold

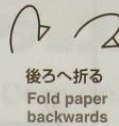

山折り Mountain fold

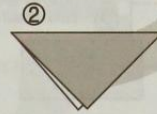

折り方の技法 Basic Folding Skills

中わり折り Inside-reverse fold

内側を割るようにして
カドを出すように折る
Push the corner in
the middle.

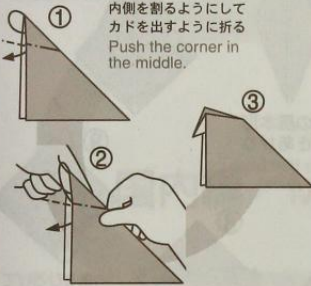

かぶせ折り Outside-reverse fold

内側を開いてかぶせる
ように折る
Open and fold outside.

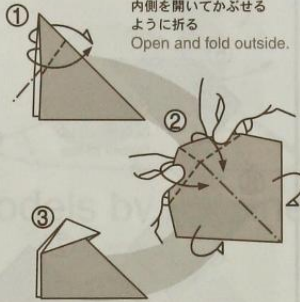

内側をひろげてつぶすように折る Squash fold

角度が違ったり、一部分で
あったりすることもある
Many types of total/partial
squashing are possible.

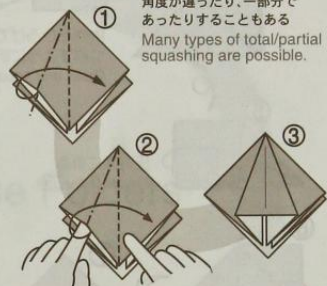

いろいろな記号 Symbols

折り筋をつける

Making a crease line

一度折ってから戻して
折り筋をつける
Fold and mark a
crease line, then
unfold.

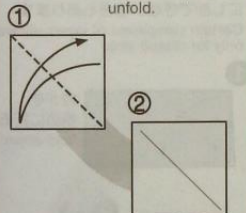

裏返す Turn paper over

おりがみを裏返す
上下の位置は
変わらない
Don't rotate the
paper upside
down.

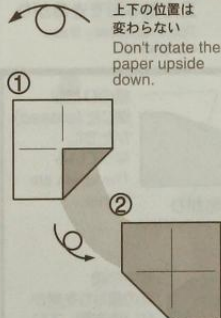

段折り Pleat fold

横から見ると
段になっている
ように見える
Pleats are formed
when you look
from the side

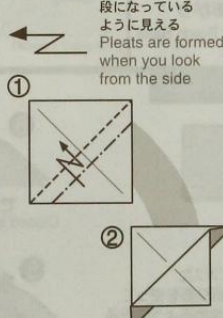

下の部分を出すように折る Release bottom flap when making a fold

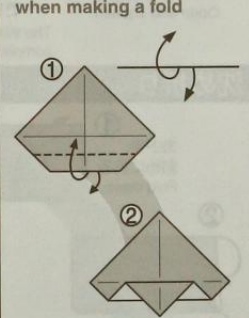

次の図が
大きくなる
A magnified view



仮想線・透視線
A hidden line



押す・つぶす
Push paper in



引き出す
Pull out



ひろげる Open up



○と○を
合わせて折る
Match circled points



巻くように折る
Roll the flap by
repeated folds

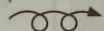

注意するところ
Marked points



次の図の見る位置が変わる
Paper position changes
(rotation)

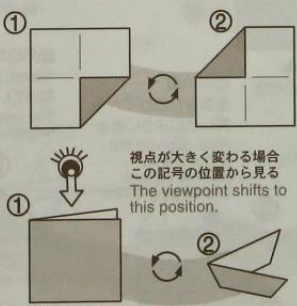

等分記号 Division

長さの等分 Dividing the length

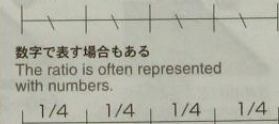

角度の等分
Dividing the
angle

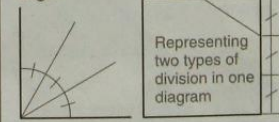

基本形 / 沈め折り Preliminary Bases and Sink

基本形 Preliminary bases

風船基本形 Water Bomb Base

① 半分に折る
Fold in half.

② 半分に折る
Fold in half again.

③ 内側をひろげて つぶすように折る
Open and squash.

④ 反対側に折る
Swivel to the left.

⑤ 内側をひろげて つぶすように折る
Open and squash.

⑥ 内側をひろげて つぶすように折る
Open and squash.

⑦ 風船基本形 できあがり
The Water Bomb Base completed.

正方形基本形と鶴の基本形 Preliminary Base / Bird Base

① 三角に折る
Fold corner to corner.

② 三角に折る
Fold in half.

③ 内側をひろげて つぶすように折る
Open and squash.

④ 反対側に折る
Swivel to the left.

⑤ 内側をひろげて つぶすように折る
Open and squash.

⑥ 内側をひろげて つぶすように折る
Open and squash.

⑦ 正方形基本形 できあがり
The Preliminary Base completed.

⑧ 縁を中心に合わせて 折り筋をつける
Fold the lower edges to the center diagonal.

⑨ 内側をひろげて つぶすように折る
Open, swivel up and squash.

⑩ 反対側も ⑧~⑨と同じ
Repeat ⑧~⑨ on the back.

⑪ 鶴の基本形 できあがり
The Bird Base completed.

沈め折り Open sink / Closed sink

① カドを斜めに折る
Fold down.

② カドを内側に折る
Inside reverse fold.

③ 沈め折りをする部分にしっかりと折り筋をつける
Mark the crease line to use for sink.

④ Open sink (オープン・シンク)
つけた折り筋を使って沈めるように折る
Push the arrowed corner inside ...

⑤ 途中の図 全体をひろげてから押し込むように折る
After opening the corner lightly, push in without overlapping layers.

⑥ できあがり
Open sink completed.

⑦ 紙のひだが開いた (open) かたちになっている
The layers can be reopened.

⑧ 途中の図 紙の重なりを開かないまま押し込むように折る
without opening the corner. Push in with layers overlapped to each other.

⑨ できあがり
Closed sink completed.

⑩ 紙のひだが閉じた (closed) かたちになっている
The layers are locked.

ひだの形によっては closed sink にしかできない場合もあります
Certain complexes of layers allows only for closed sink.

① カドを斜めに折る
Fold down.

② 沈め折りをする部分にしっかりと折り筋をつける
Mark the crease line to use for sink.

③ つけた折り筋を使って沈めるように折る
Push in the corner.

④ できあがり
The closed sink completed.

第12回

折紙探偵団コンベンション折り図集

12th Origami Tanteidan Convention Book

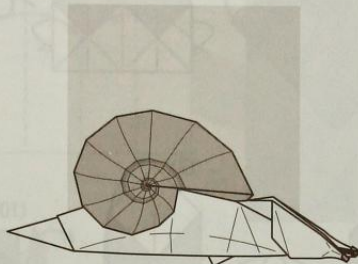

国内編 / Models by Japanese Folders

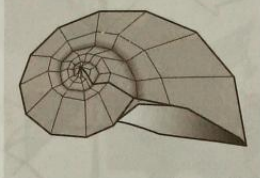

©Meguro Toshiyuki

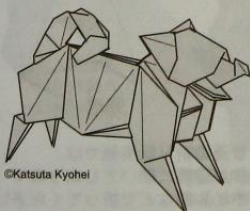

©Katsuta Kyohel

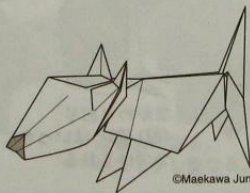

©Maekawa Jun

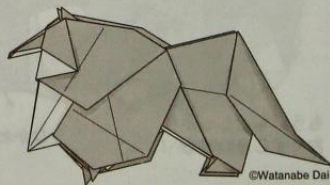

©Watanabe Dai

ペンギんくん (ちび)

Penguin-Kun, chick

木村良寿
Kimura Yoshihisa

2004.07.25 創作 Designed
2005.08.05 作図 Drawn
05 年東京コンベンション
にて講習済

1/3 のおりすじをつける

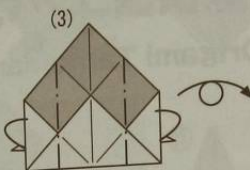
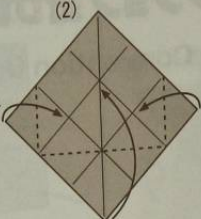
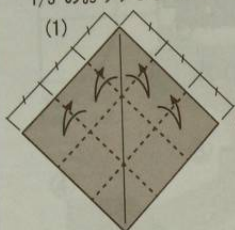

なかりおり

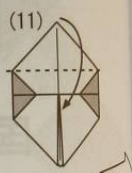
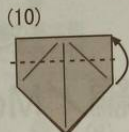

かどを内側にいれる

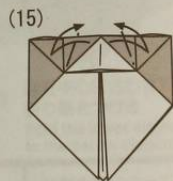
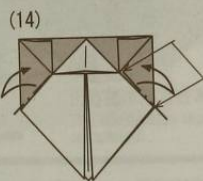
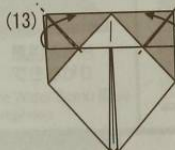
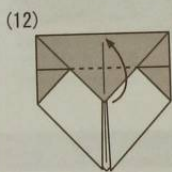

このはんでしっかりと
やまおりのおりすじをつける

こちらはまがっているていどの
ゆるいおりすじをつける

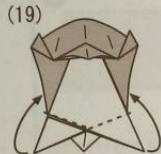
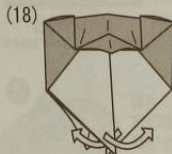
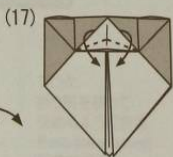
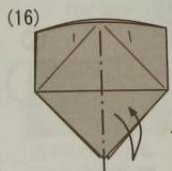

やまおりで
おりすじをつける

かぶせおりかな?

かみをずらして
くみあわせる

あしをまえに
だすように折る

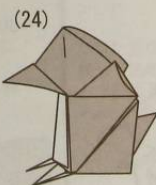
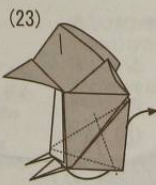
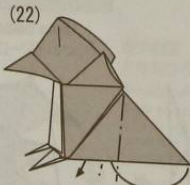

もういちどしっかりと
おりすじをつける

なかりおり

なかりおり
(22)(23) はいっき
つづけておる

完成

普通の折り紙用紙では
体が自然に開いてしまうので
ホイル紙などで折ってください

海亀

Sea Turtle

創作：宮本眞理子/2006.5

この作品は折紙教室用に考えた作品です。折図の工程は教えるときの工程となっています。講師をされる方々の参考になれば幸いです。

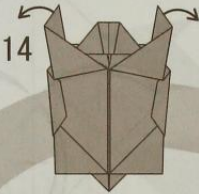
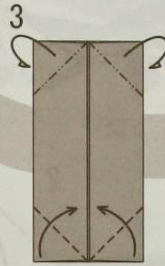
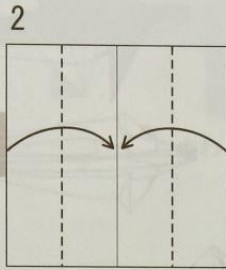
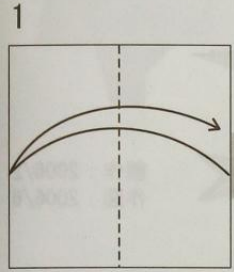
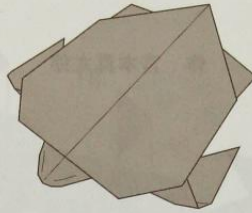

引っ張るように
拡げる。

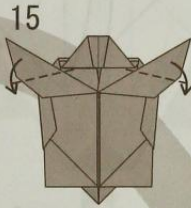

首を細くする。

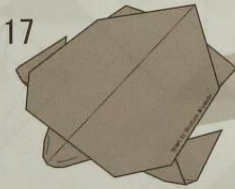
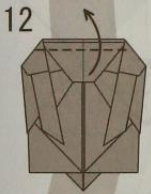
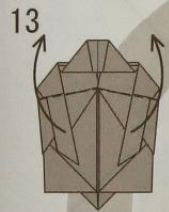
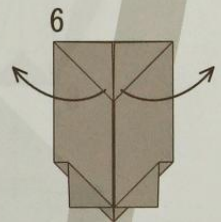
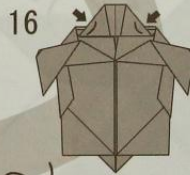

できあがり。

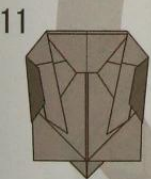
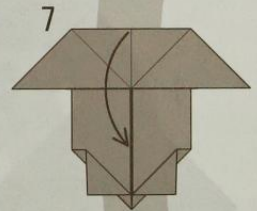

黒い部分を
手の内側へ
はさみ込む。

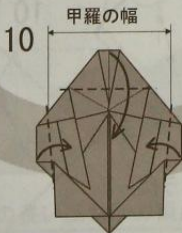

甲羅の形に
なるように折る。

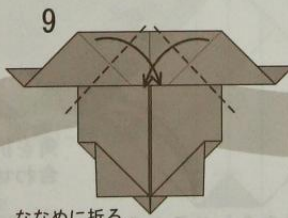

ななめに折る。
中央で少し重なる。

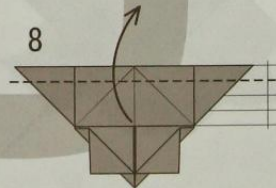

1/4で折る

イルカ

作：宮本真太郎

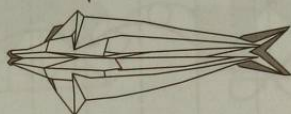
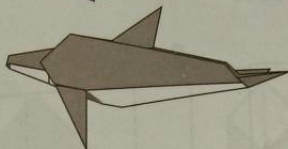
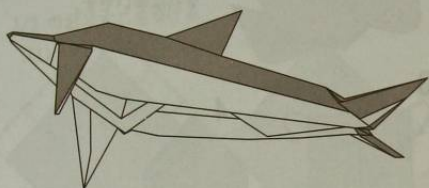

創作：2006/2
作図：2006/6

1

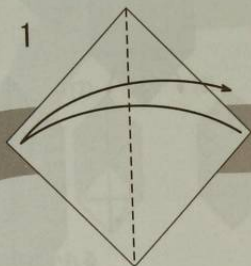

2

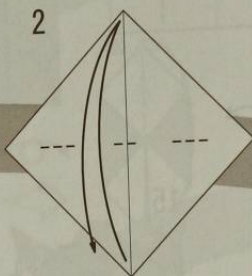

3

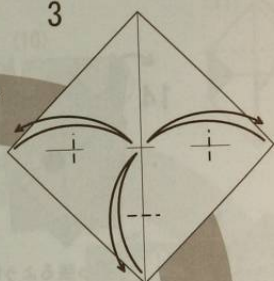

4

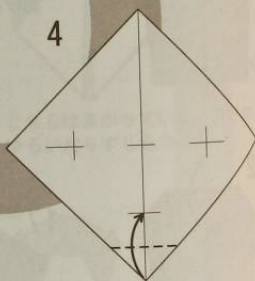

6

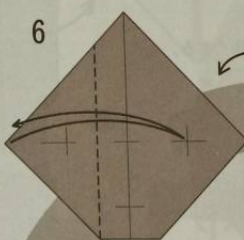

5

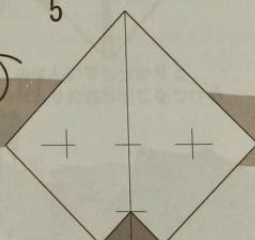

7

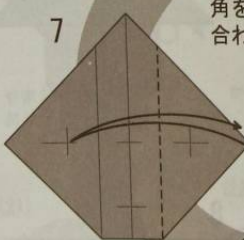

角を十字線に
合わせるように

8

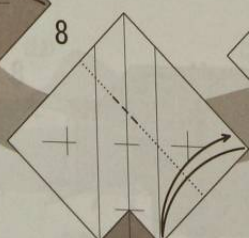

角と角を合わせるように

9

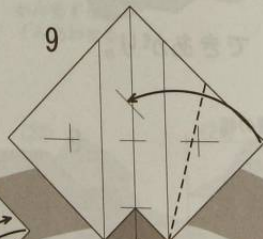

角を折線に
合わせるように

10

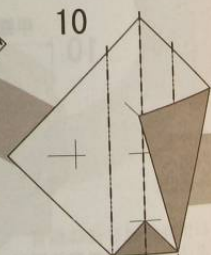

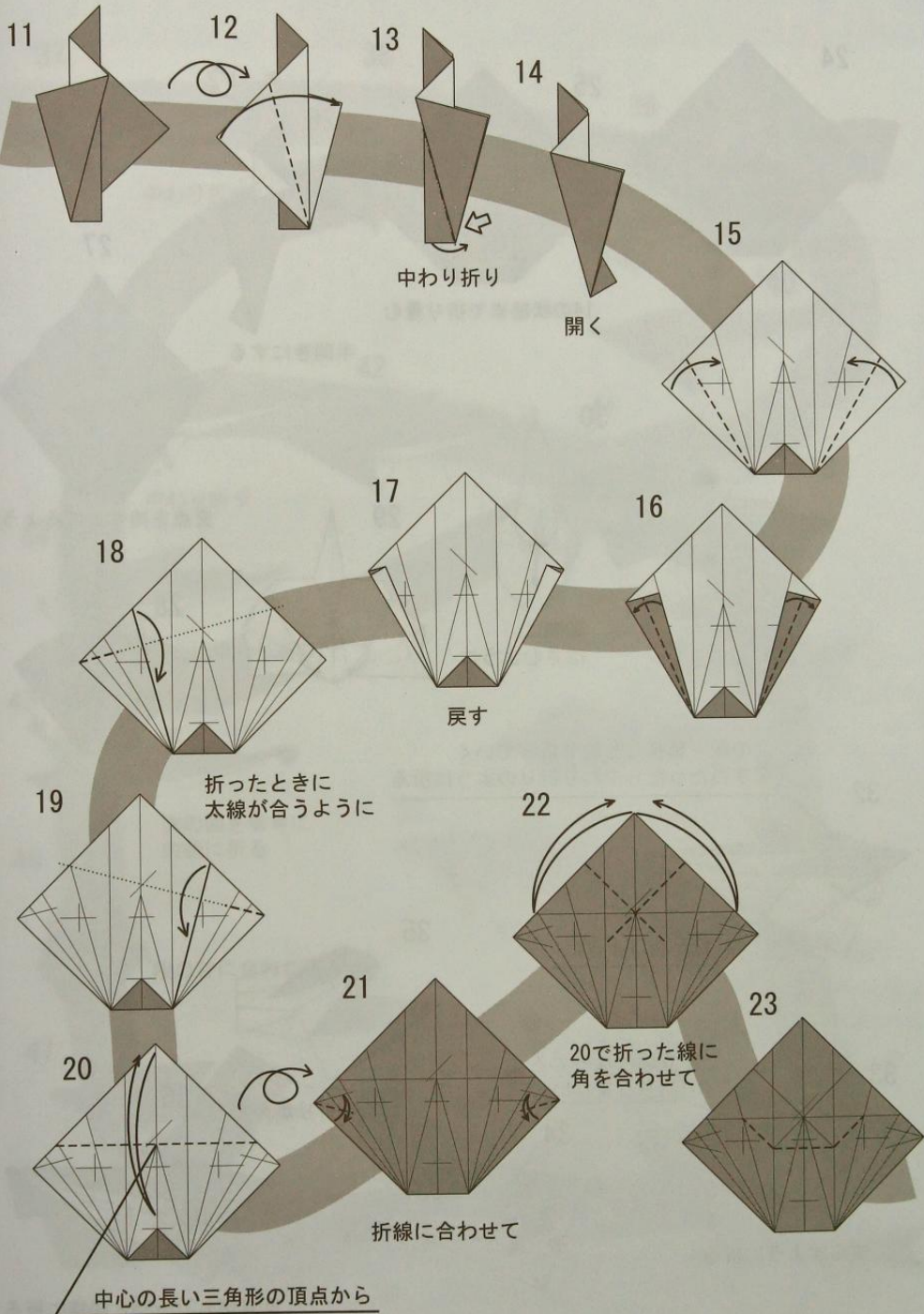

24

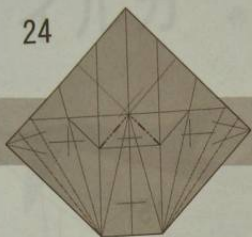

25

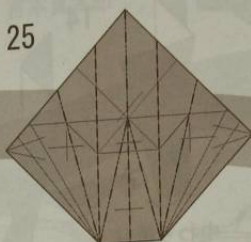

14の状態まで折り畳む

26



半開きにする

27

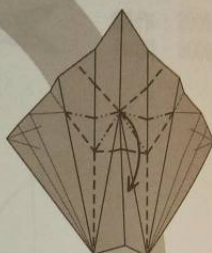

交点を持ち上げるように

31



↑

30



隙間にはさむように

29

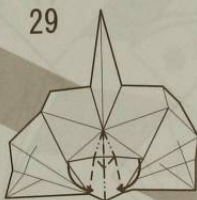

28

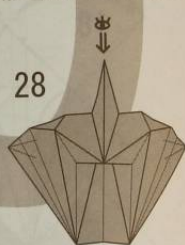

↓

上の縁を延長した線で折っていく
突き当たったら中わり折りのように折る

32

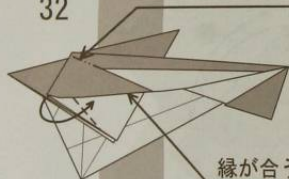

縁が合うように

33

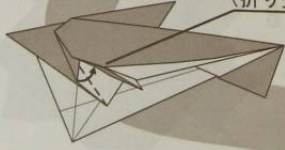

ずらすように折る

半立体になっている
(折り畳まない)

34

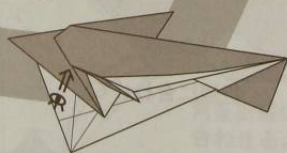

35

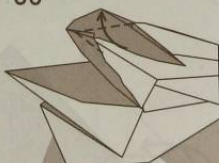

ヒレを折りかえす

36



反対側も31~35と同様に折る

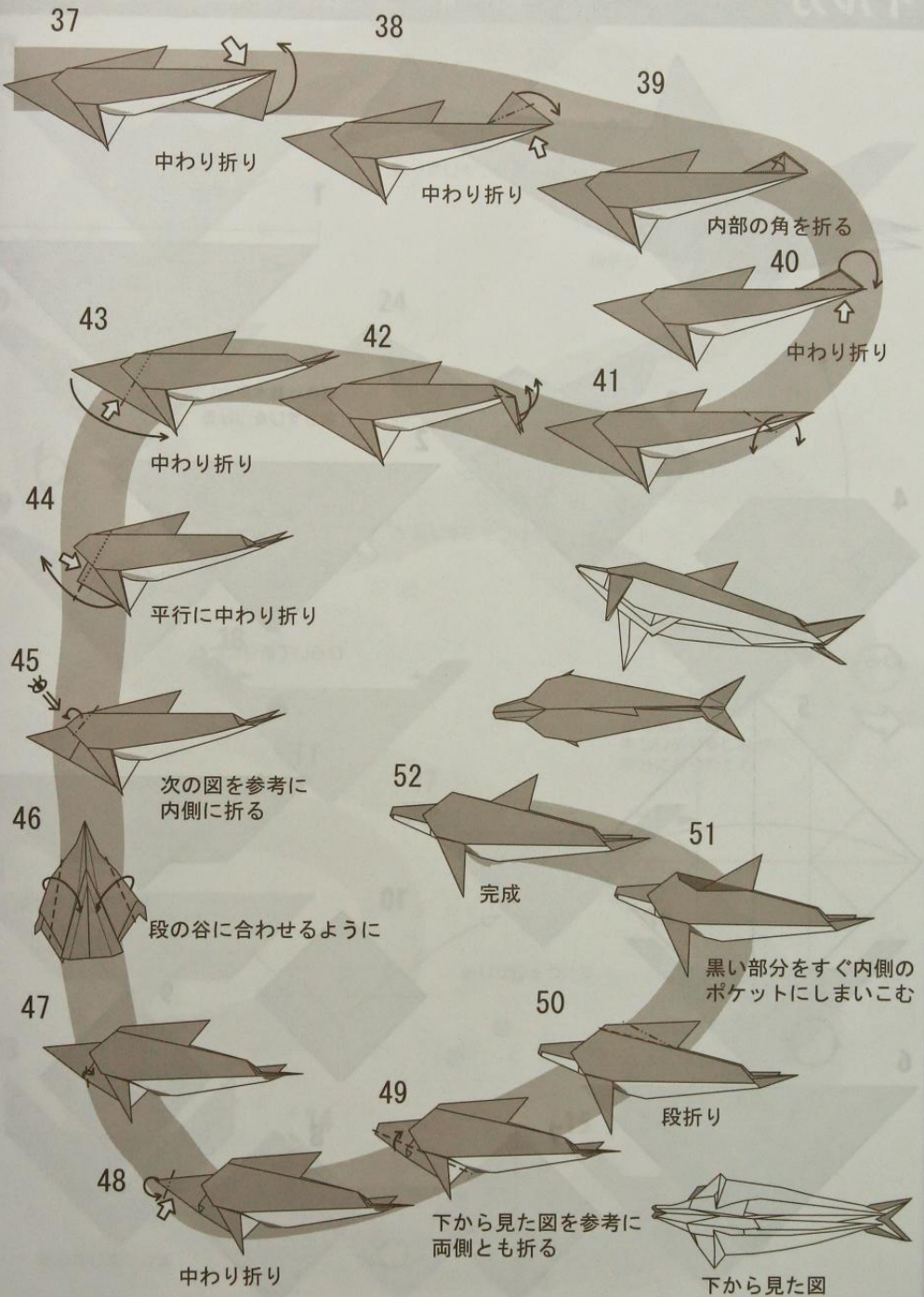

イルカ

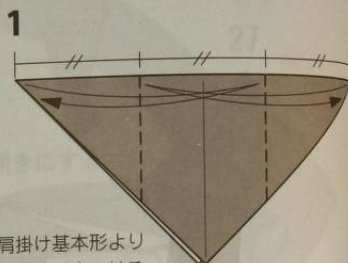
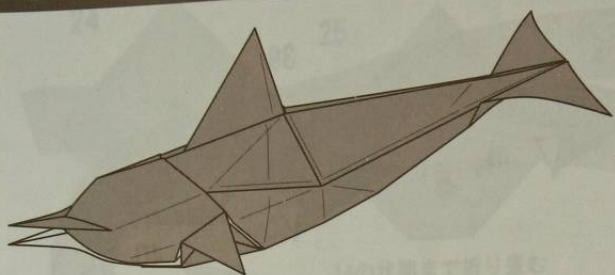

肩掛け基本形より
折りすじをつける

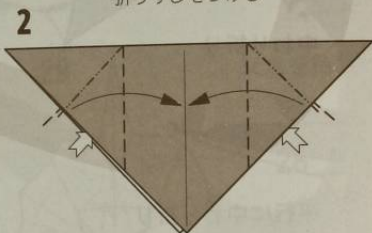

ひらいて折りたたむ

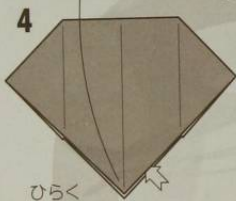
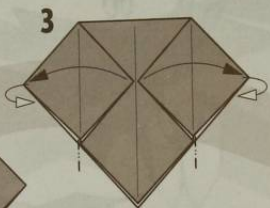

ひらく

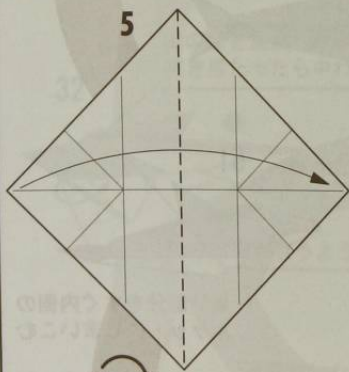

5

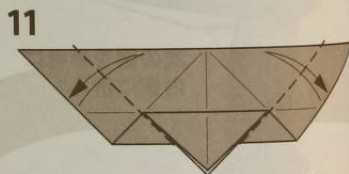

折りすじをつける

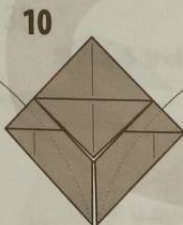

10

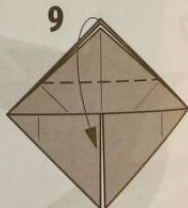

9

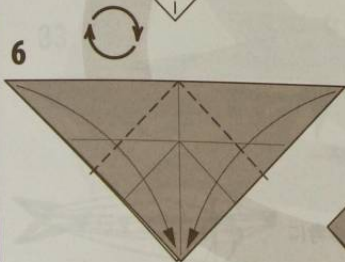

6

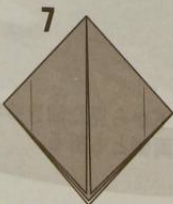

7

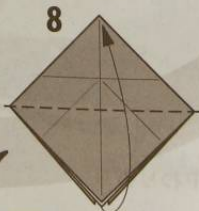

8

21

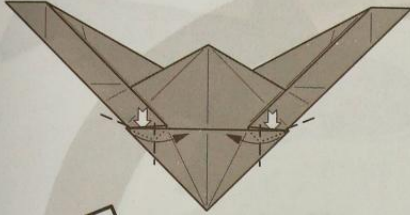

20



ひらいて折りたたむ

19

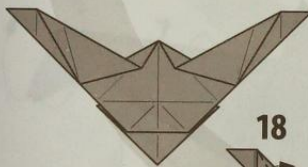

折りすじをつける

12

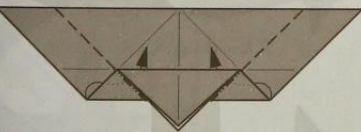

中わり折り

13

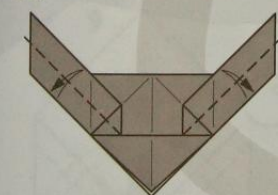

折りすじをつける

22

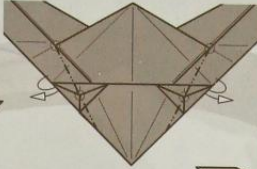

折りすじをつける

24

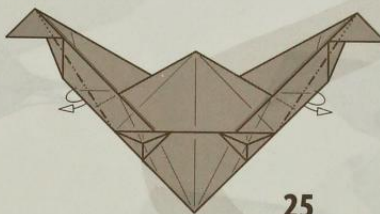

折りすじをつける

23

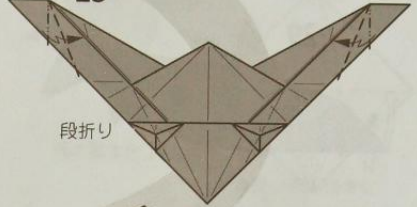

段折り

18



段折り

17

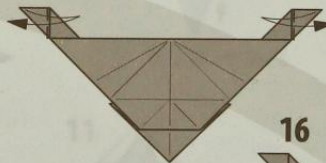

折りすじをつける

16

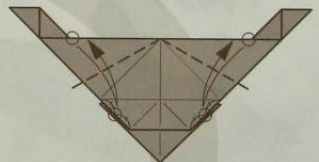

よせるように
中わり折りをしながら
半分折りたたむ

15

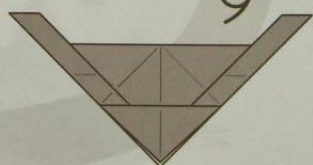

中わり折り

14

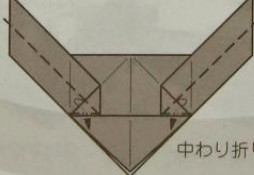

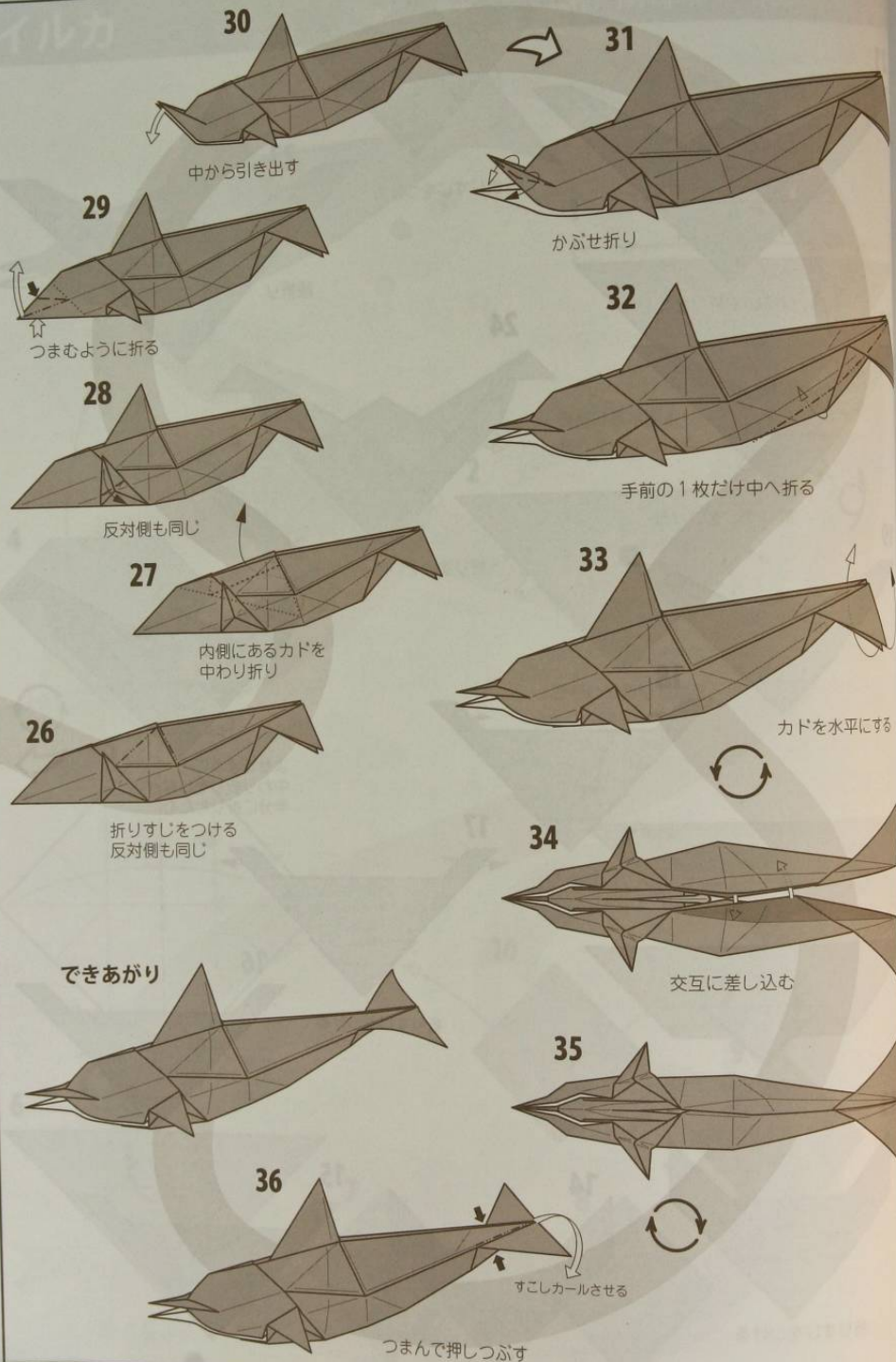

カブトガニ

創作：青木 良 試作：2003.8.6 修正：2005.12 作図：2006.6.18

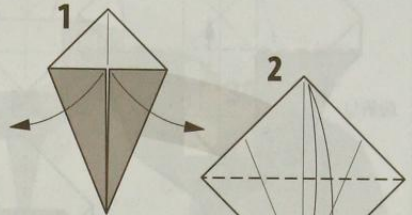
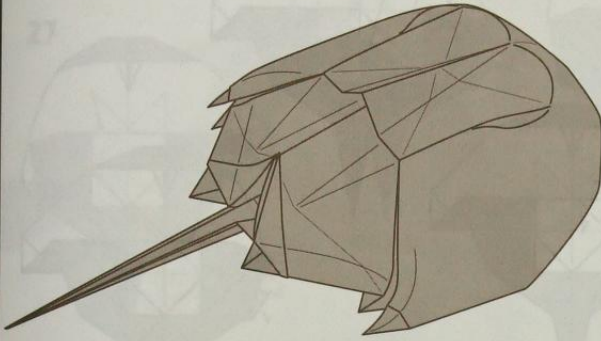

扇の基本形より

折りすじをつける

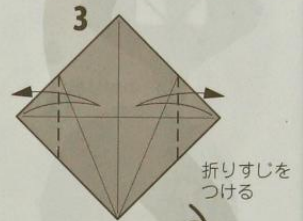

折りすじをつける

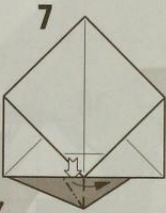

ひらいて折りたため

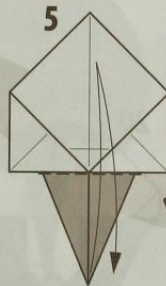
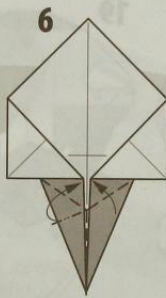

折りすじをつける

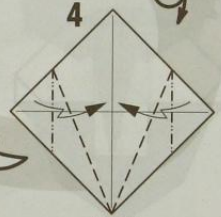

段折り

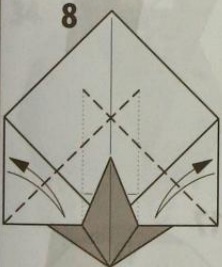

折りすじをつける

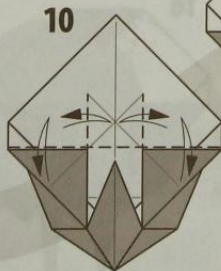
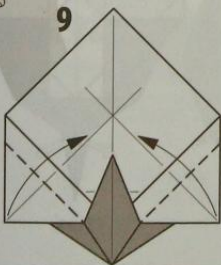

折りすじをつける

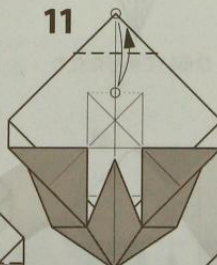

折りすじをつける

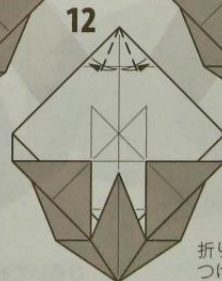

折りすじをつける

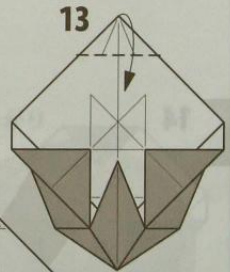

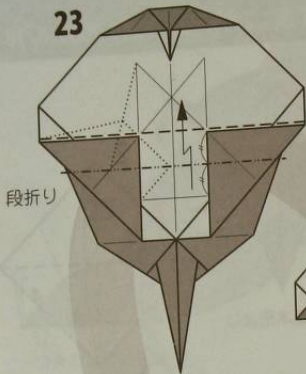

段折り

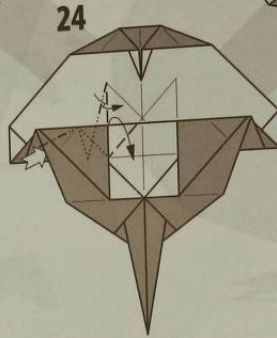

段折りしながら
ひらいて折りたたむ

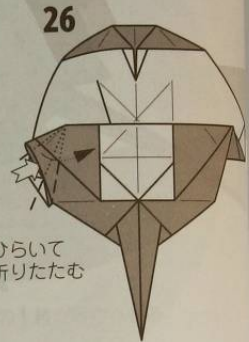
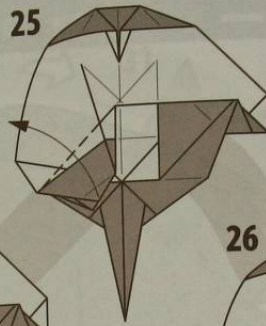

ひらいて
折りたたむ



中わり折り

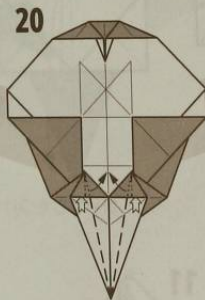
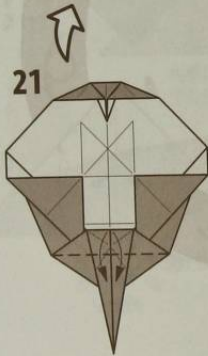

ひらいて折りたたむ

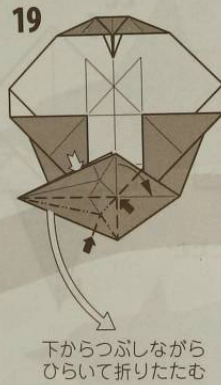

下からつぶしながら
ひらいて折りたたむ

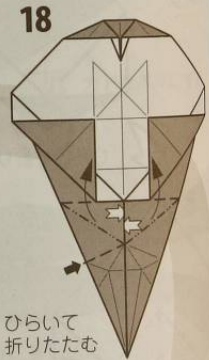

ひらいて
折りたたむ

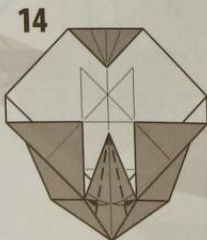

折りすじをつける

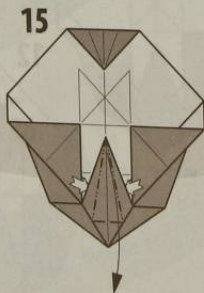

ひらいて折りたたむ

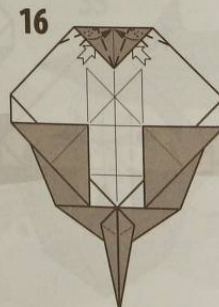

ひらいて折りたたむ

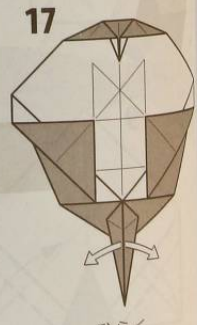

ひらく

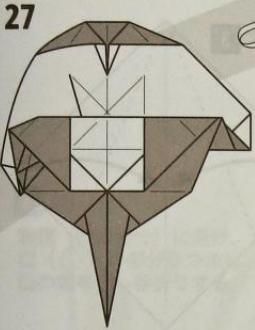

27

反対側も24~26と同じ

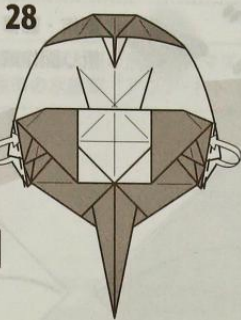

28

差し込む

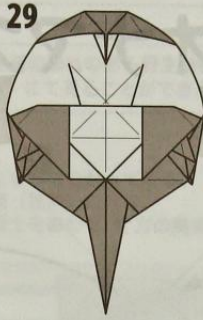

29

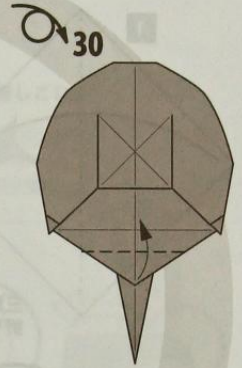

30



33

段折りしながら
中わり折り

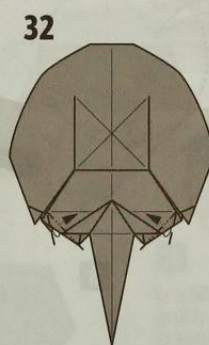

32

中わり折り

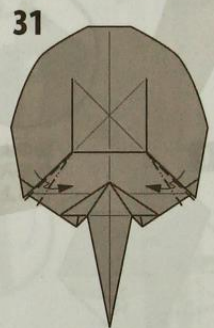

31

段折り

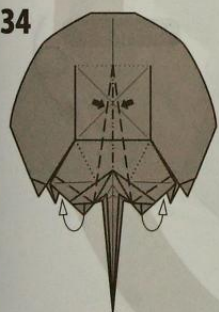

34

中心を山型にする

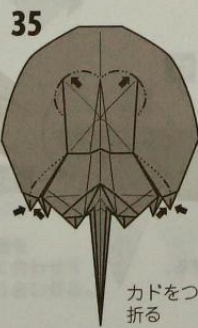

35

カドをつまむように
折る

できあがり

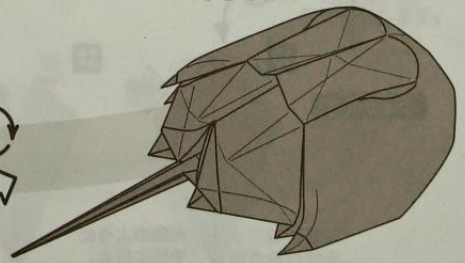

メコンオオナマズ

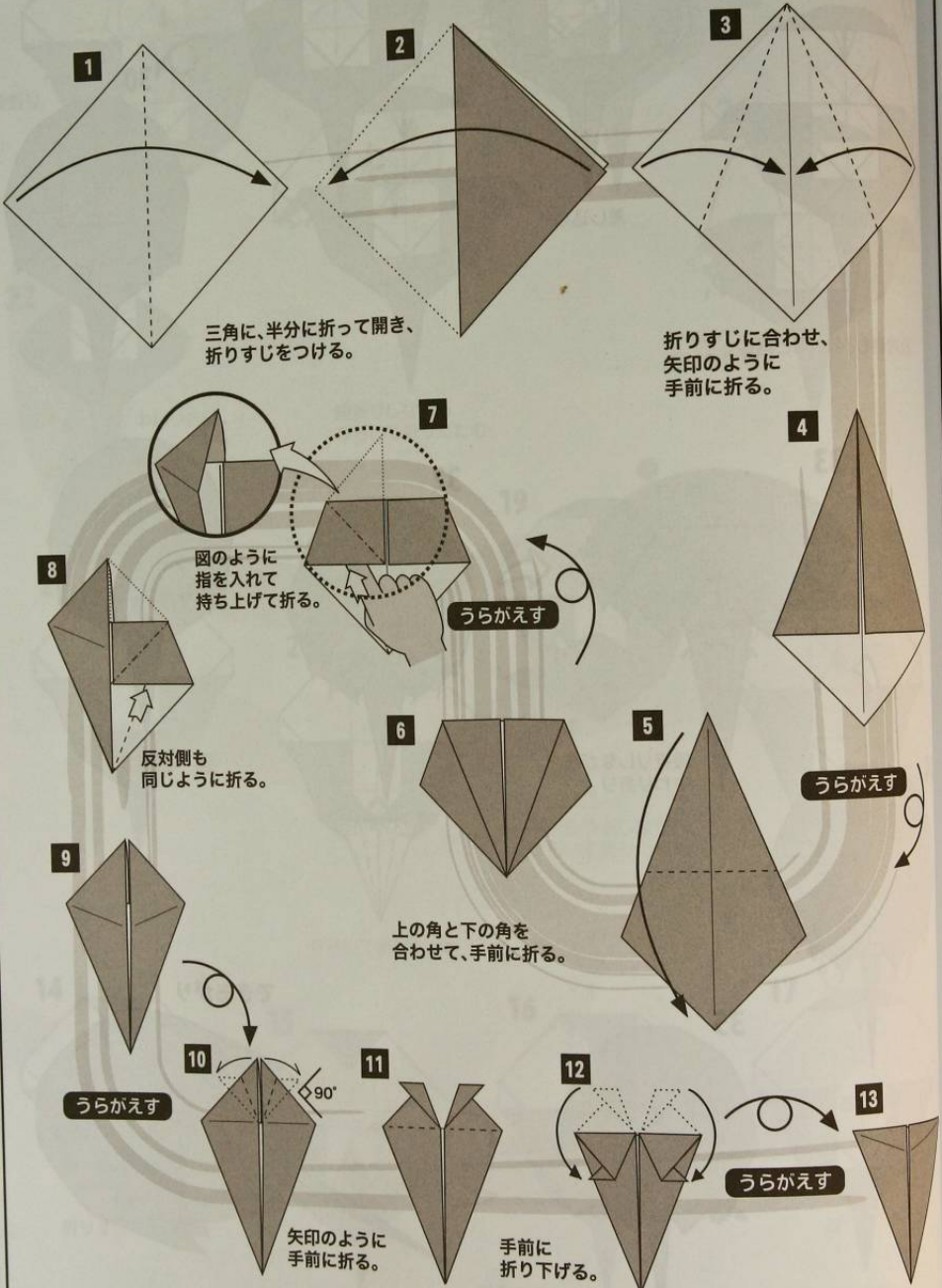

1 三角に、半分に折って開き、
折りすじをつける。

3 折りすじに合わせ、
矢印のように
手前に折る。

7 図のように
指を入れて
持ち上げて折る。

うらがえす

8 反対側も
同じように折る。

うらがえす

6 上の角と下の角を
合わせて、手前に折る。

うらがえす

10 矢印のように
手前に折る。

12 手前に
折り下げる。

うらがえす

メコンオオナマズとは

学名: *Pangasianodon gigas*

東南アジア・メコン川に生息する大型の淡水性ナマズ。絶滅の恐れのある野生動物としてワシントン条約で保護されている。岐阜県各務原市の水族館“アクア・トト ぎふ”にて見ることができる。

20 ひれを外にむかって折る。
裏側（腹側）に向け、
角同士をあわせ、片方の奥まで差しこむ。

21 表側（背の部分）に向け、
口（○）の部分をつぶし、
口の端を少し谷折りする。

うらがえす

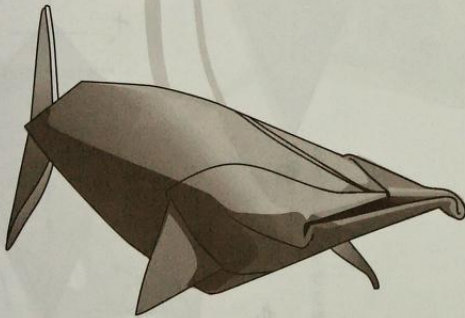

19 しっぽを折り出す **その2**
上のかさなり部分だけを
上の中わり折り。

18 しっぽを折り出す **その1**
かさなっている2まいとも
つるの頭のように中わり折り。

17
横向きにします。

14
三角の両端を
○の中心に合わせて
手前に折り合わせる。

15
うらがえす

16
たてに半分に
折り合わせる。

ネズミ式

2003.03.02 制作

物
種

2006.06.22 折図 水野香織 (折)

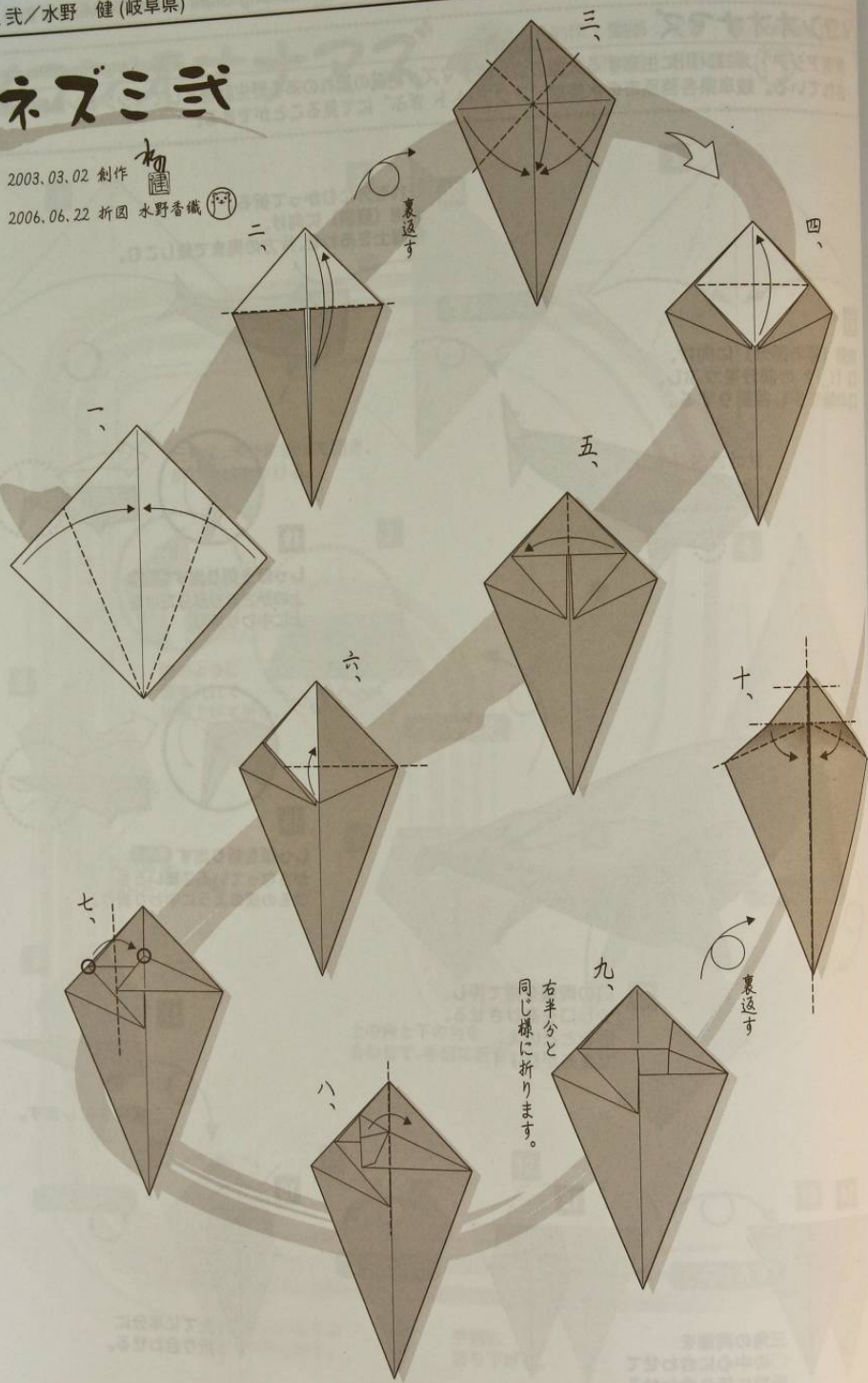

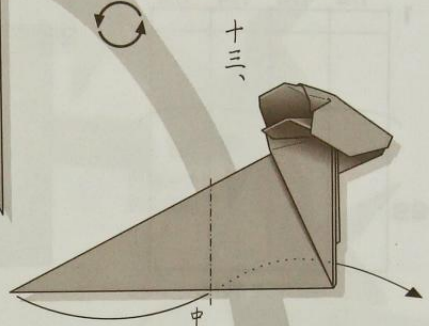
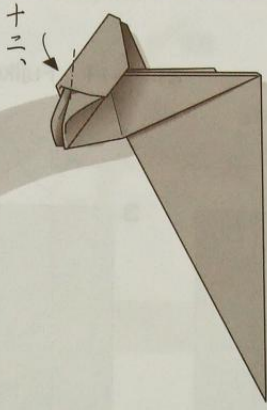
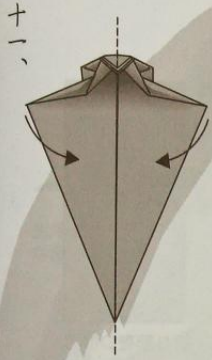

出来上がり。



尻尾を波打たせる様に形作ります。

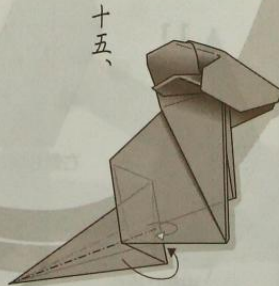
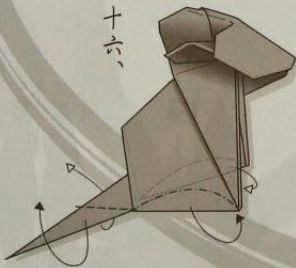
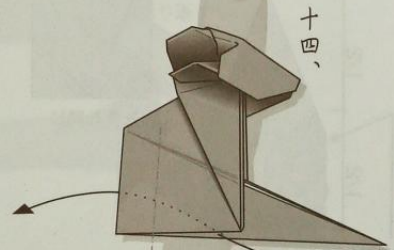

Rabbit うさぎ

2005-11 Fujikura Atsuo 藤倉 敦夫

紙裏面から見る white side up

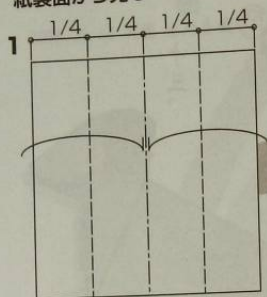

折り筋をつける

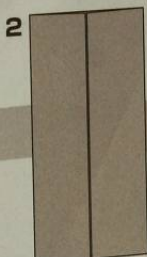

折り筋をつける



折り筋をつける

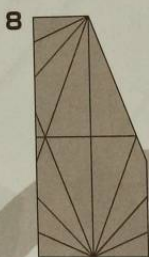

左側も同じ



中割り折り

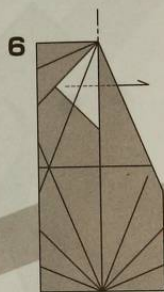

中割り折り



中割り折り

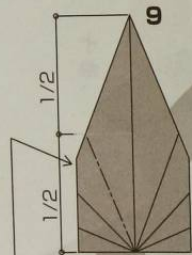

OPEN SINK

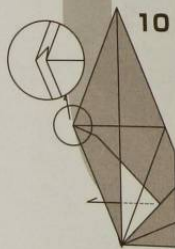

中割り折り



中割り折り

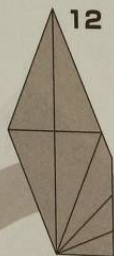

右側も同じ



上の角をつまみ
折りしながら、
全体を半分にする

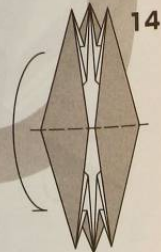

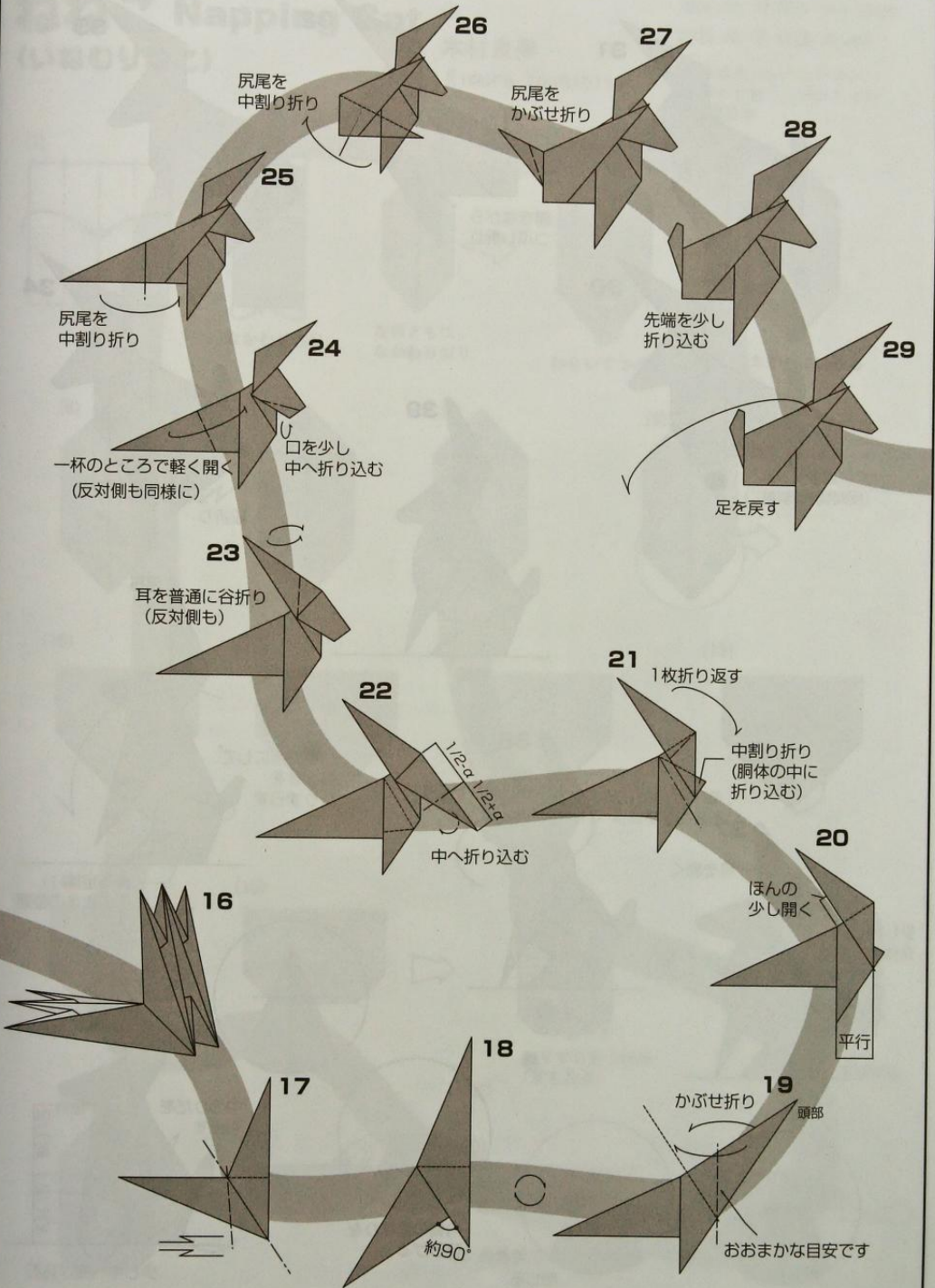

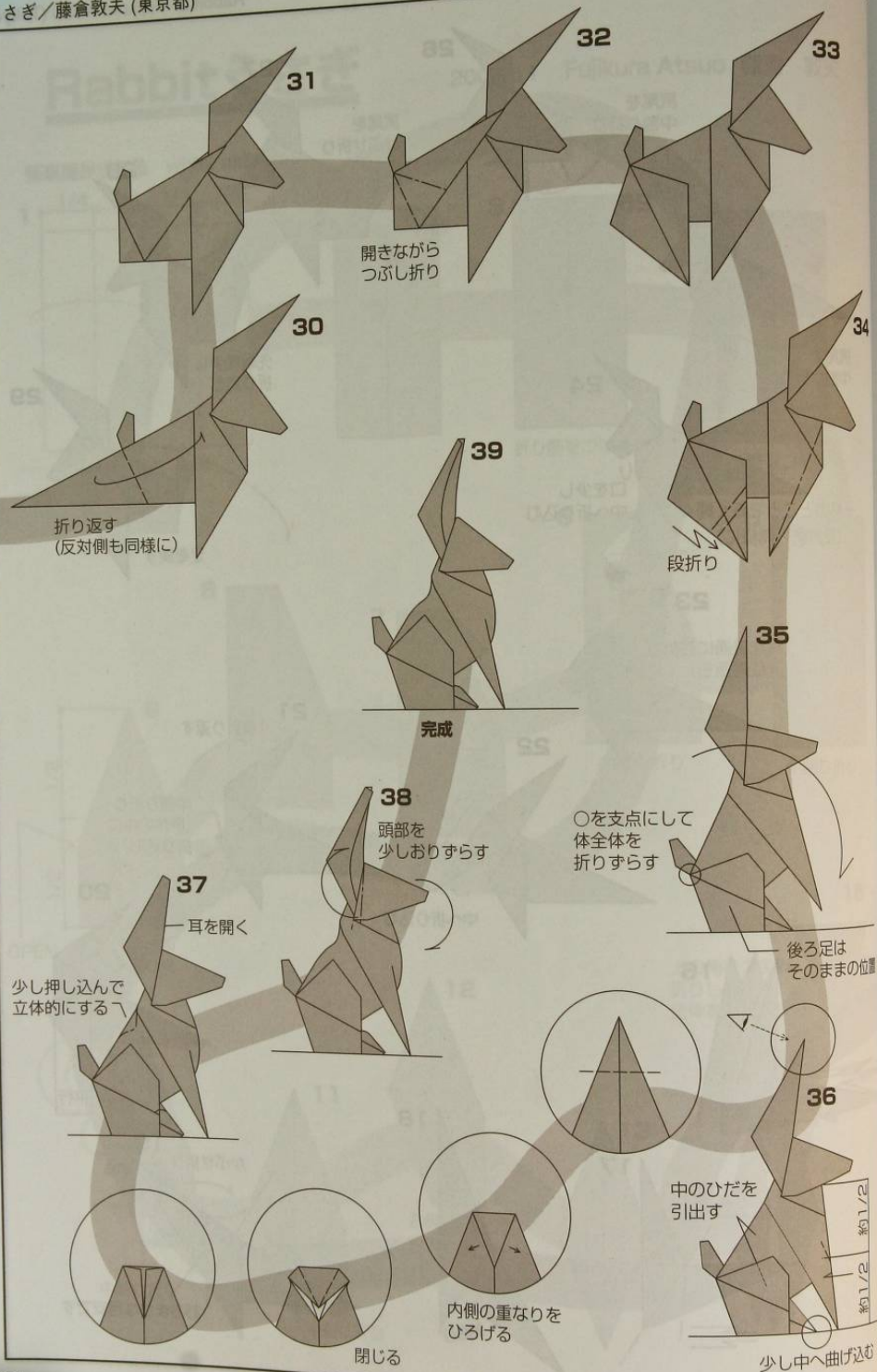

31

32

33

30

34

39

35

開きながら
つぶし折り

折り返す
(反対側も同様に)

段折り

完成

38

頭部を
少しおりずらす

○を支点にして
体全体を
折りずらす

後ろ足は
そのままの位置

耳を開く

少し押し込んで
立体的にする

36

中のひだを
引出す

内側の重なりを
ひろげる

閉じる

少し中へ曲げ込む

ね
い

(1)

ねねこ Napping Cat

(いねむりねこ)

木村良寿
Kimura Yoshihisa

2005.06.12 創作 Designed

2005.08.02 作図 Drawn

05 年東京コンベンション
05 年名古屋コンベンション
にて講習済

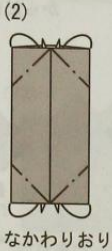
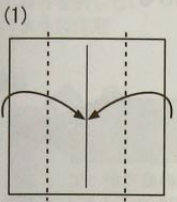

なかわりおり

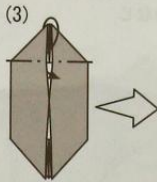

左右ともに
なかわりおり

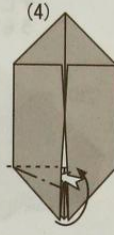

ひらいてつぶす

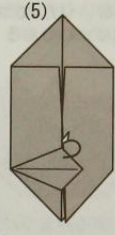

うちがわにのいる

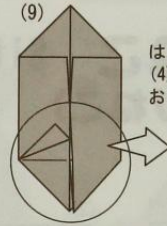

はんたいがわも
(4) から (8) と
おなじにおる

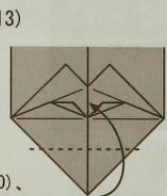
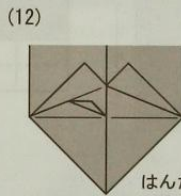
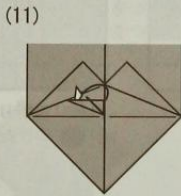
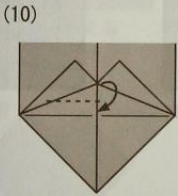

はんたいがわも (10)、
(11) とおなじにおる

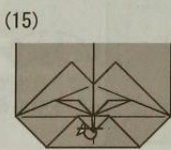
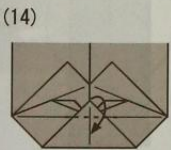

おりすじをつける
(耳もおる)



おりすじをつける

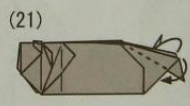
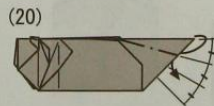
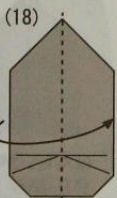

1/3 の角度でなかわりおり

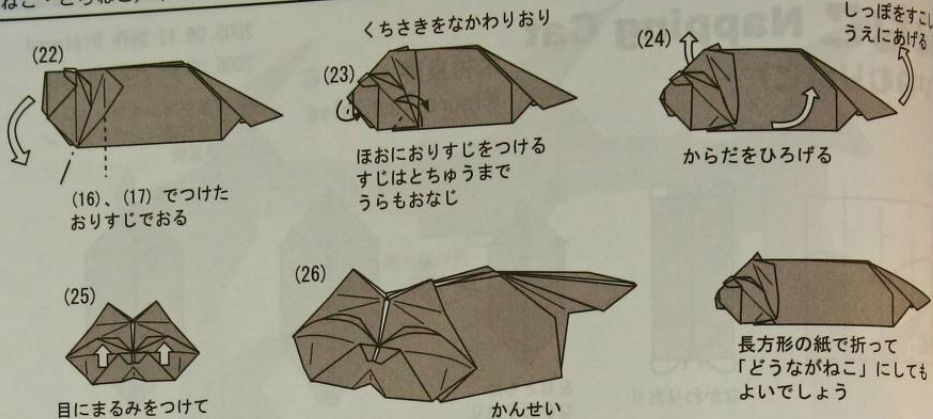

ころねこ Sitting Cat (おすわりねこ)

木村良寿
Kimura Yoshihisa

2005.07.10 創作 Designed
2006.06.28 作図 Drawn
05 年東京コンベンション
にて講習済

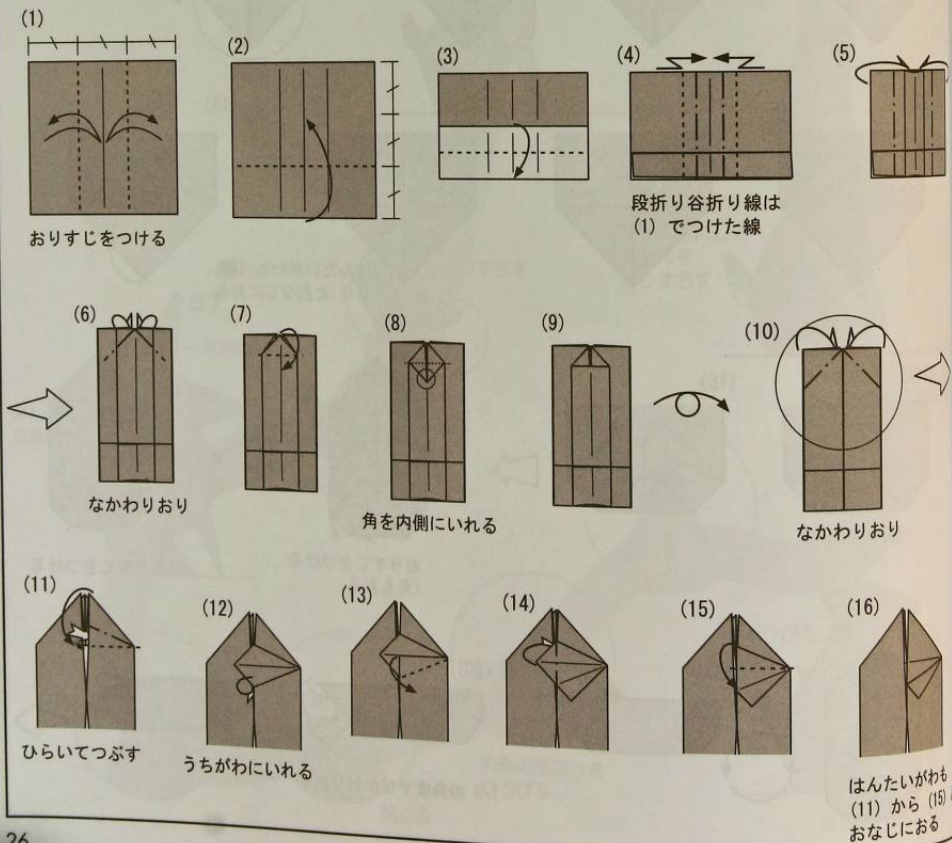

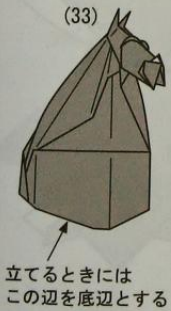
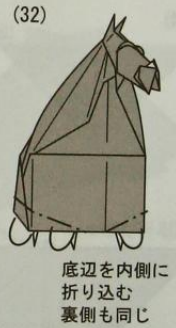
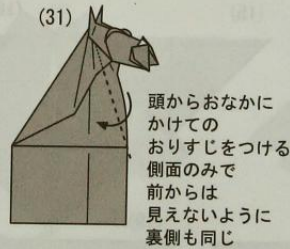
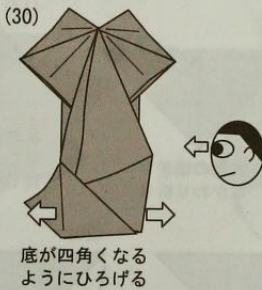
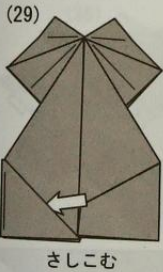
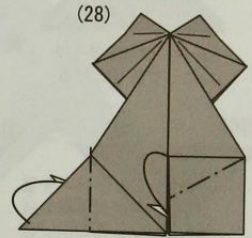
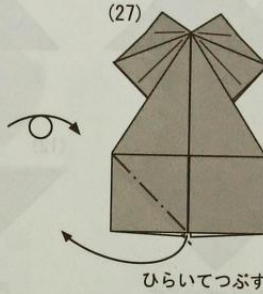
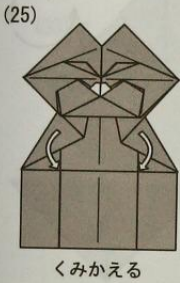
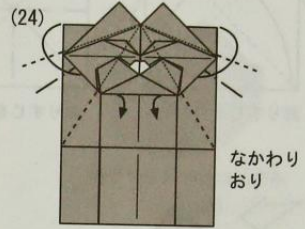
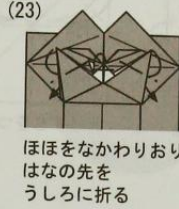
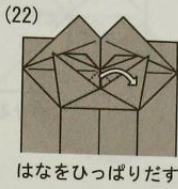
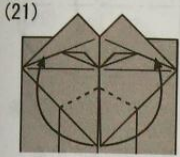
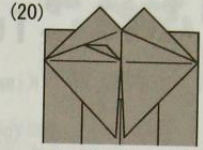
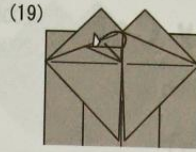
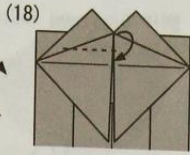

でぶねこ Tubby Cat

木村良寿 Kimura Yoshihisa

(1) おりすじをつける

(2) おりすじをつける

(3) おりすじをつける

(4) おりすじをつける

(5) (1) (2) のおりすじ
つかつて風船の
基本形にまとめる

(6)

(7) なかわり折り

(8)

(9)

(10) (3) (4) のおりすじを
つかつて折り上げる

(11) ひらいてつぶす

(12) 内側にいれる

(13)

(14)

(15)

(16) 内側の紙を
なかわり折り

(17) 反対側も
(11) から (16) と
同じに折る

(18) 一番下の紙
以外を段折り

(19)

(20)

(21)

(22)

(23) なかわり折り

(24)

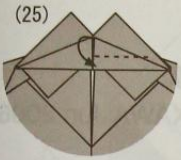

(25)

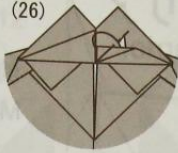

(26)

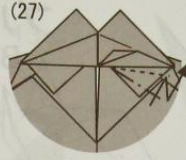

(27)

ヒゲを段折り

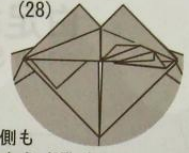

(28)

反対側も
(25) から (27) と
同じに折る

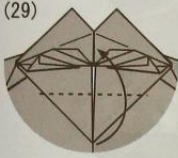

(29)

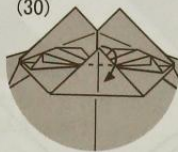

(30)

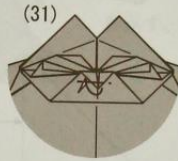

(31)

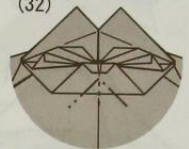

(32)

折りすじをつけ口にする

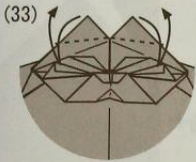

(33)

耳に折りすじをつける

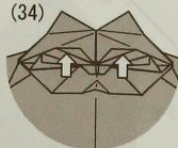

(34)

目にまるみをつけて

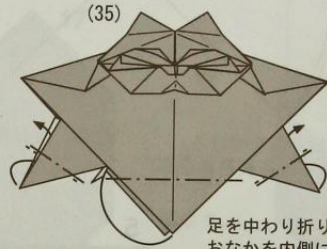

(35)

足を中わり折り
おなかを内側に折る
しっぽは折らないように

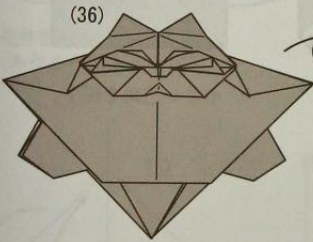

(36)

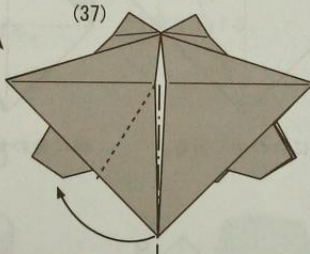

(37)

引きよせるようにして
しっぽを片側にあおす

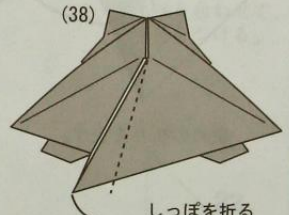

(38)

しっぽを折る
中わりではない

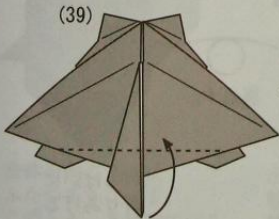

(39)

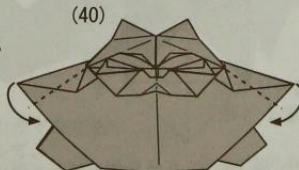

(40)

手を前に折る

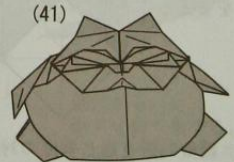

(41)

かんせい

白足袋猫
White Socks

ブルテリア
Bull Terrier

前川淳
MAEKAWA Jun 2006

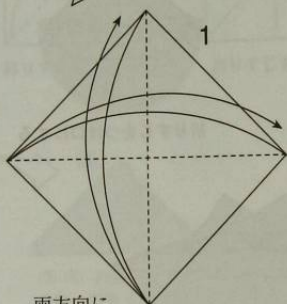

1
両方向に
対角線の折り目をつける。
(ブルテリアは裏表逆になる)

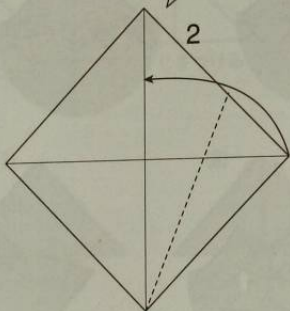

2
片側だけ対角線に合わせて折る。

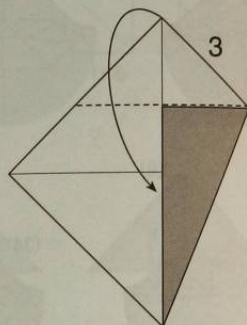

3
縁に合わせて折る。

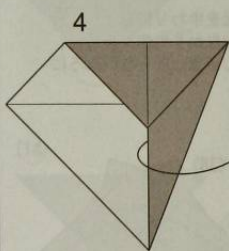

4
斜めの折りを戻す。

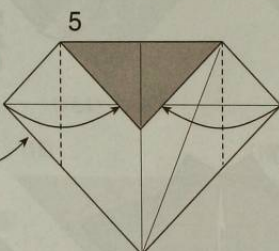

5
縁に合わせて折る。

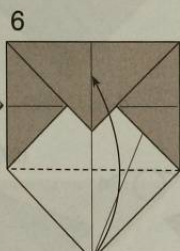

6
縁に合わせて折る。

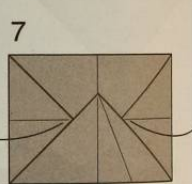

7
小さい三角を戻す。

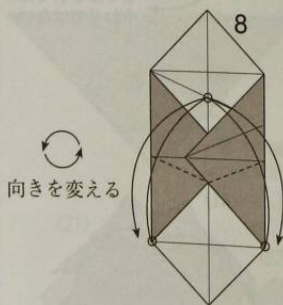

8
向きを変える

斜めの折り目と垂直の対角線の
交点に合わせて折り目をつける。

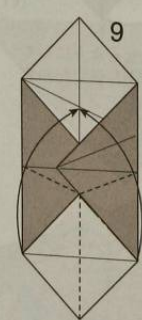

9
8 図の折り目を使って
つまみ折りをする。

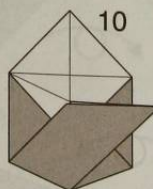

10
裏返す。



11
いっぱい
折りあげる。

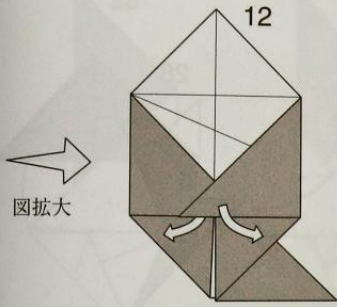

図拡大

からまっているふたつのカドを折り目を変えずにひきはがす。

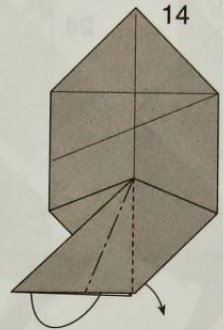
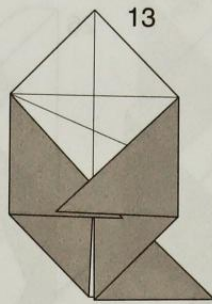

真ん中で開いてつぶす。

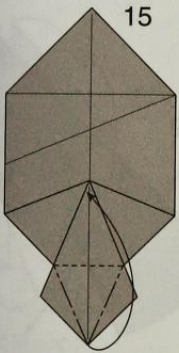

花卉折りする。
(あやめの基本形と同じ)

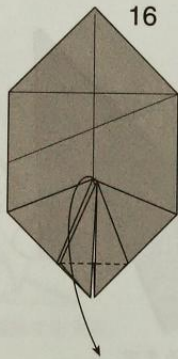

折り下げる。

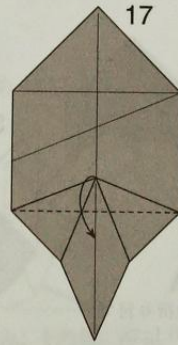

折り下げる。

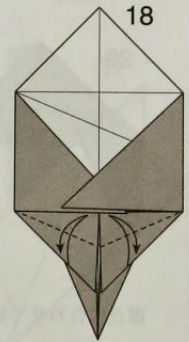

縁と縁を合わせて、
折り目をつける。

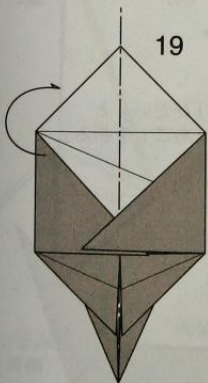

全体を向こう側に
ふたつ折りにする。
このとき、とびでている
カドを一緒に折らない。

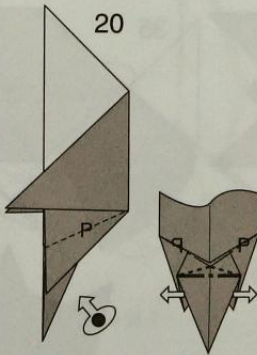

小さい三角のカドを左右に
軽く引っ張って、
横一直線の山折りの折り目
(図の太い鎖線)をつくる。

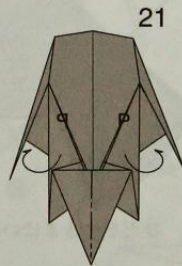

「後ろから見た
立体的な途中の図」

P線がかぶせ
折りする。

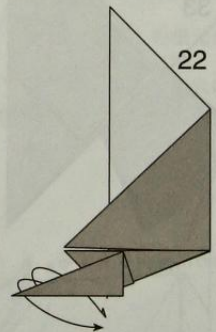

根元から
かぶせ折りする。
(ここまでの、犬猫共通)

犬は次ページ

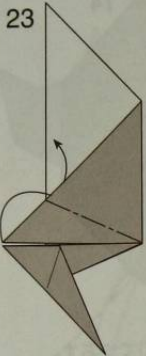

23 中割折りする。
(両側)

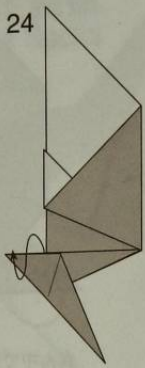

24 中割折りする。
(部分的に裏返す
ような折りである)
(両側)

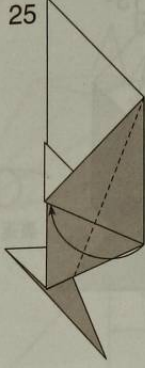

25 縁に合わせて折る。
(両側)



26 縁に沿って
中割折りする。



28 折り目をつける。

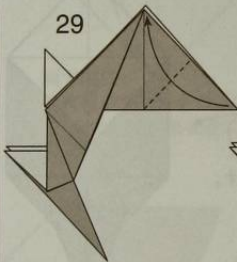

29 頂点に合わせて折る。

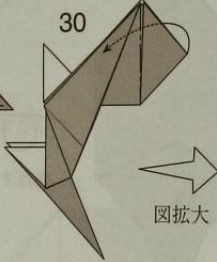

30 28 図の折り目で
中割折りして、
三つの頂点が
そろうようにする。



図拡大

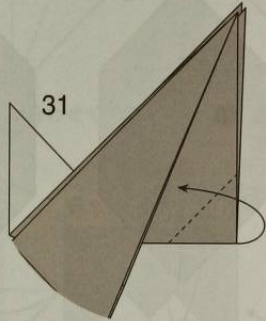

31 段のところまで、
45 度の角度で谷折りする。

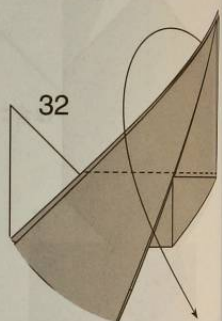

32 真ん中で開いてつぶす。

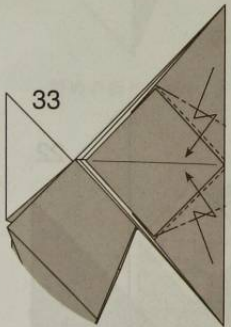

33 斜めに段折りする。

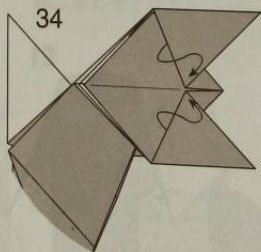

34 ひだをすきまに入れる。

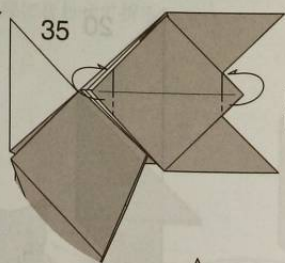

35 「ひたい」と
「あご」を折る。

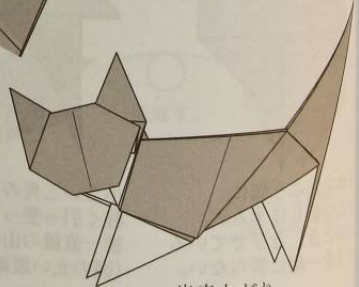

出来上がり

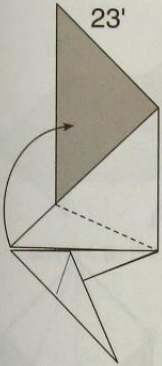

23'

「白足袋猫」の 23 から。
(ただし、裏表は逆)
カドを根元で谷折りする。
(両側)

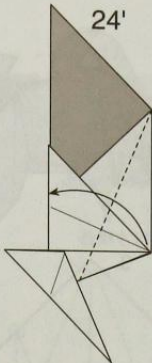

24'

縁に合わせて折る。
(両側)

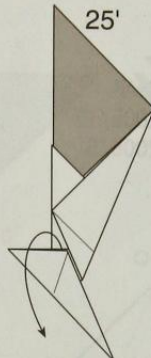

25'

いっぱい引き伸ばして
つぶす。(両側)



26'

谷折り。(両側)

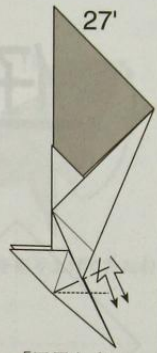

27'

「尻尾」を
内側で斜めに
段降りする。
(角度は 28' 図
参照)



28'

縁に沿って
中割折りをする。

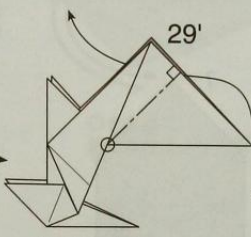

29'

中割折りをする。

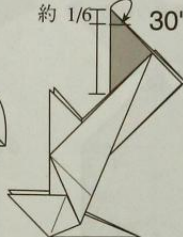

約 1/6

30'

「鼻先」を内側に折る。



図拡大

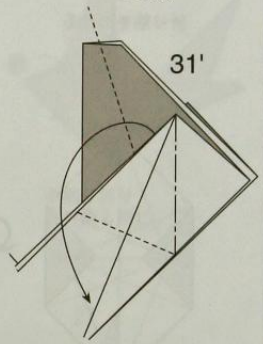

31'

つまみ折りでカドをつくる。
(両側)

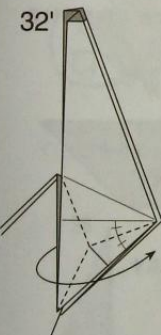

32'

つまみ折り。
(両側)

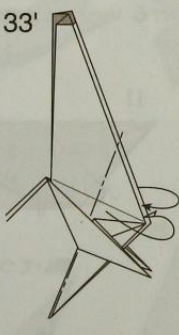

33'

両側のひだを
真ん中に寄せる。

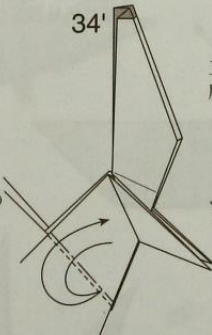

34'

折り目をつける。

立体的に
広げる。



35'

「上から見た図」

「耳」の根元を
押しつけて
「耳」を中央に
寄せる。

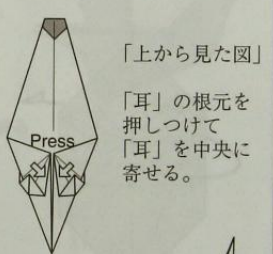

Press

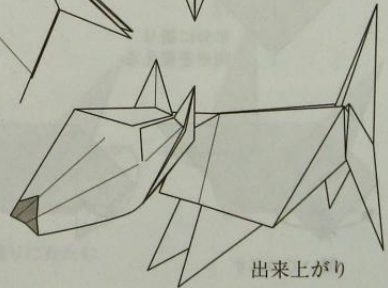

出来上がり

仔犬

勝田恭平
作：2005/12
図：2006/6

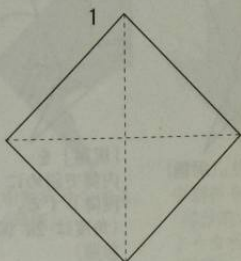
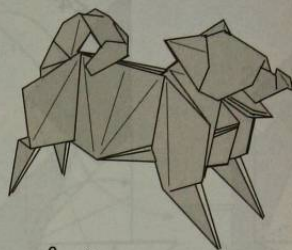

1
折り筋をつける

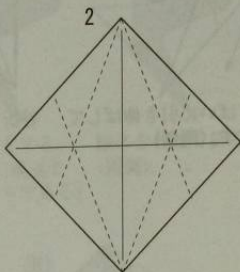

2
折り筋をつける

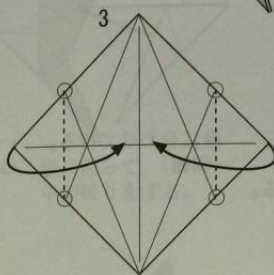

3
○と○を結ぶ線で折る

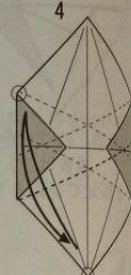

4
○と○を合わせるように
折り筋をつける
残り3カ所も同じ

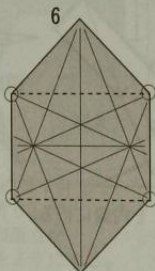
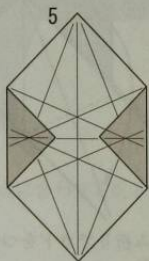

5
6
○と○を結ぶ線で
折り筋をつける

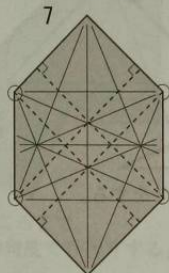

7
○を基準に対角の辺に
垂直に折り筋をつける

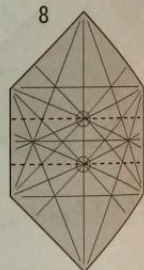

8
○を基準に折り筋をつける

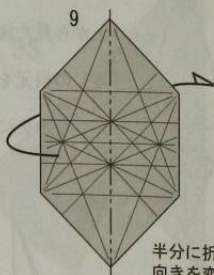

9
半分に折り
向きを変える

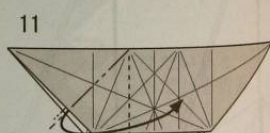
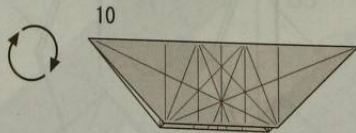

10
11
開いてつぶす

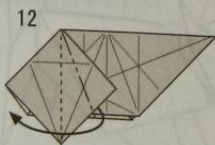

12
開いてつぶす

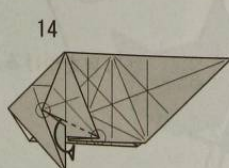
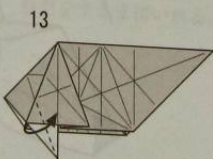

13
14
○と○を結ぶ線で
後ろに折り込む

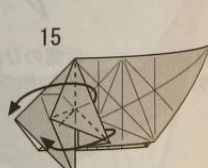

15
フチを合わせるように
折りたたむ

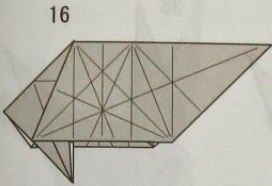

16
反対側も12-15と同じ

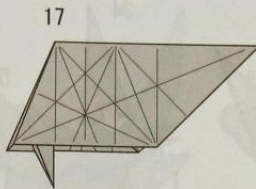

17
右側も11-16と同じ

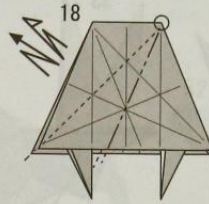

18
○を支点に両側に段折り

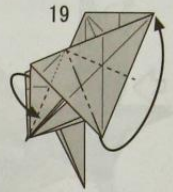

19
カドを折り上げてたたむ

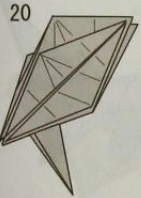

20
21
○を支点に
回転させるように折る

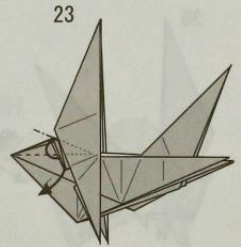
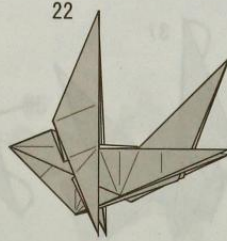

22
23
中割り折り
反対側も同じ

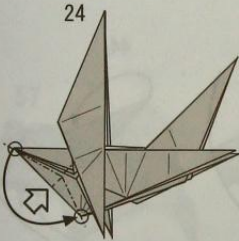

24
矢印の位置を押し潰しながら
○と○を合わせるように折る

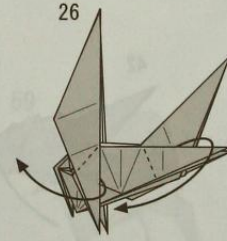
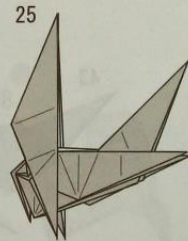

25
26
カドをめいっばいのところで折る
以下36まで反対側も同じ

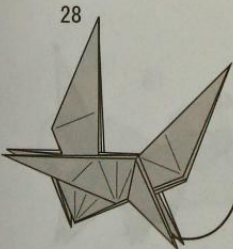
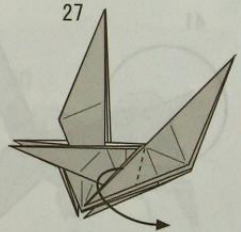

28
カドを25の状態に戻す

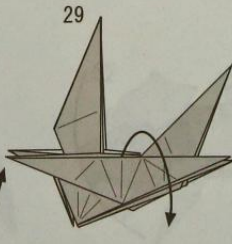

29
軽く開く

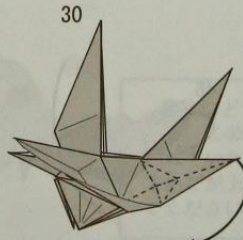

30
山谷の線通りにたたむ

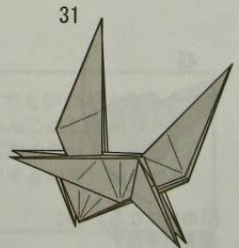

32

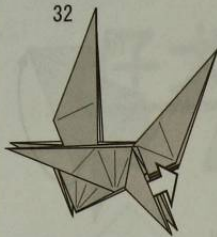

紙を引き出す

33

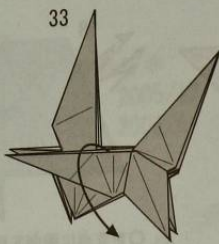

軽く開く

34

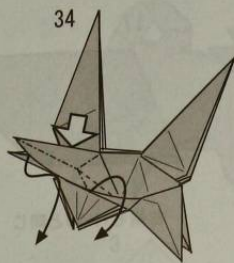

中割り折りしながら
かぶせるように折る

35



36

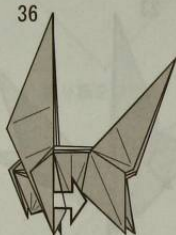

□のようになるように
紙を引き出す
言うほど簡単じゃない

37

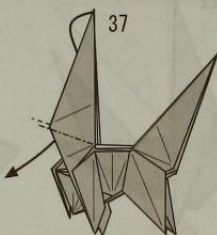

中割り折り

38

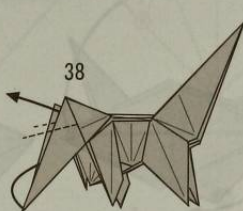

中割り折り

39

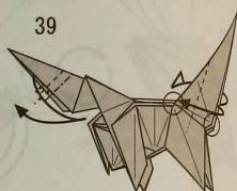

中割り折り×2

○を合わせるよ
かぶせ折り

41

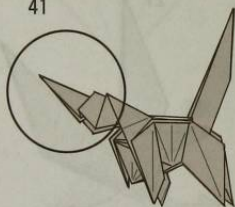

拡大

42



小さく中割り折り
反対側も同じ

43

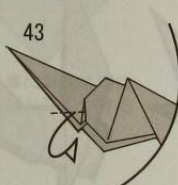

後ろに折り込む
反対側も同じ

44

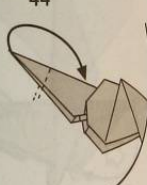

かぶせ折り
開いて谷折りでもよい

45

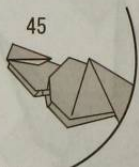

□の形になるように
紙を引き出す

46

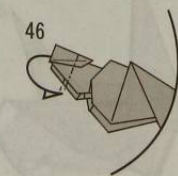

まとめて折り込む

47



拡大終了

48

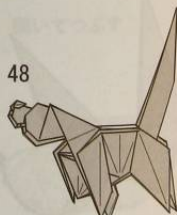

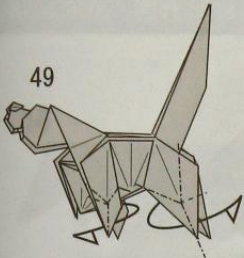

49

つまむようにして折る
反対側も同じ

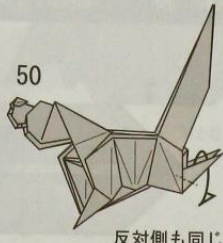

50

反対側も同じ

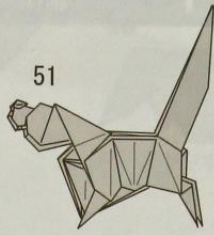

51

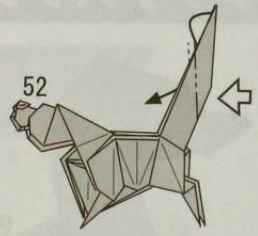

52

潰しながら中割り折り

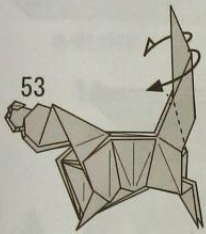

53

かぶせ折り

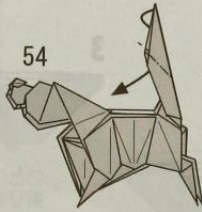

54

中割り折り

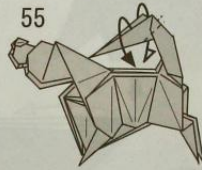

55

かぶせ折り
以下数回繰り返す

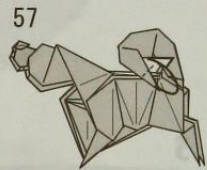

57

内側に折り込む

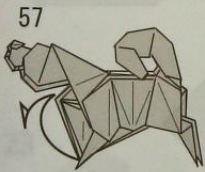

57

中割り折り×2して
下あごを作る

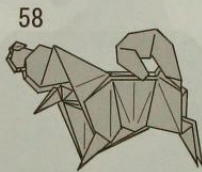

58

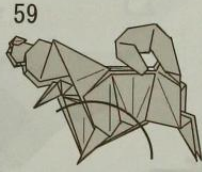

59

透視

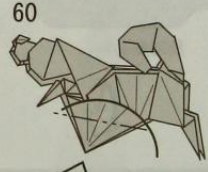

60

沈め折り

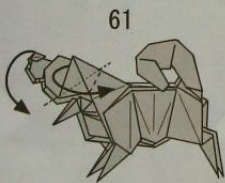

61

耳を立て、頭を下げる

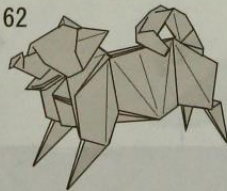

62

できあがり

最後にどうでもいいギミックとして、このわんこはしっかりと折られていれば胸の部分をつまむと下あごが上下するので、遊んでみてください。

ダックスフント

創作/青木 良

試作/2005. 8. 3 作図/2006. 6. 11

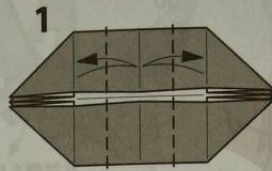
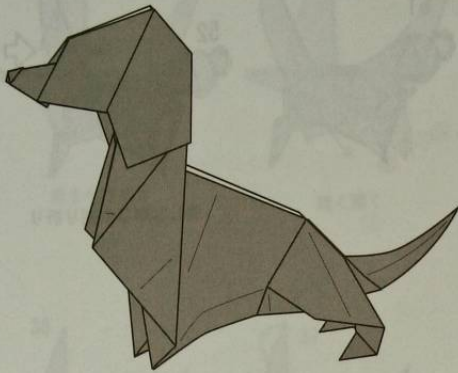

1
二そう舟基本形より
折りすじをつける

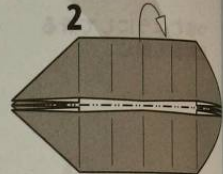

2
半分に折る

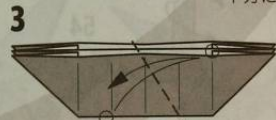

3
○と○を合わせるように
折りすじをつける

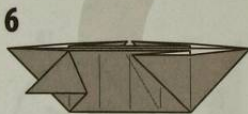
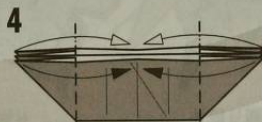

6
反対側も同じ

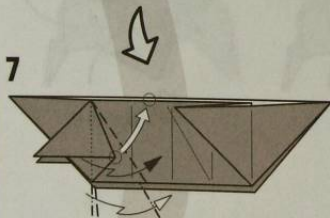

7
かぶせるように段折りをして
○と○を合わせる

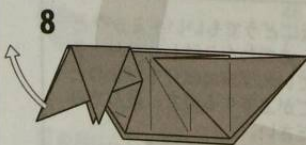

8
もどす



9
ひらく

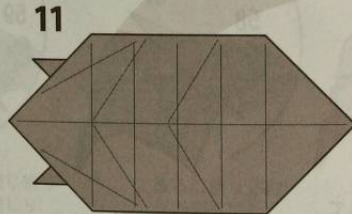

11
図 8 の形にもどす

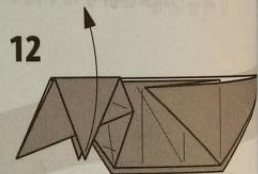

12
折りすじをつける

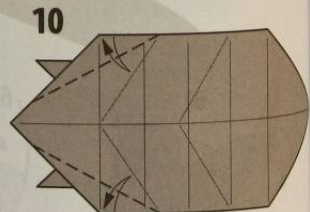

10
折りすじをつける

17



折りすじをつける

18



折りすじをつける

16

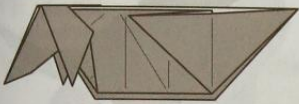

反対側も12~15と同じ

19



折りすじをつける

15



ひらいて折りたたむ

20



14

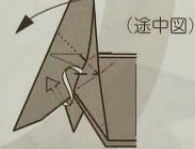

(途中図)

21



かぶせるように段折り

13

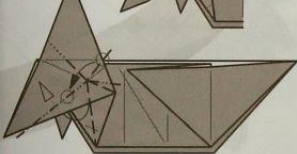

中わり折り

22



図17でつけた線に合わせて折りすじをつける

23

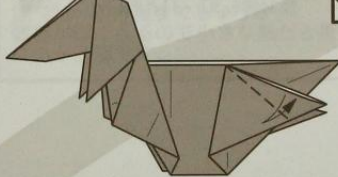
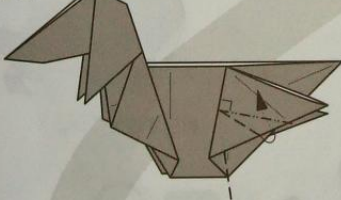

中わり折り

26

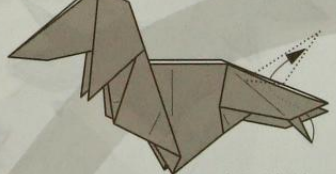

中わり折り

24

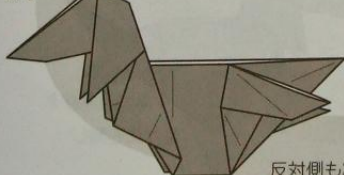

反対側も22~23と同じ

25

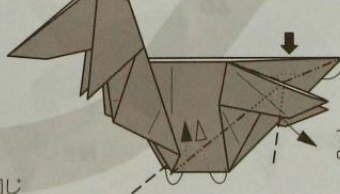

つまむようにして中わり折り

34

かぶせ折り



35

形を整える

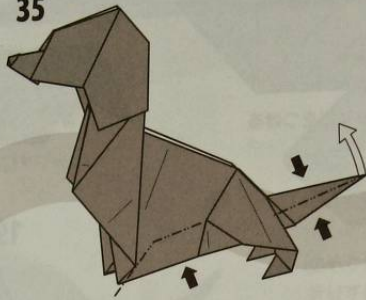

できあがり

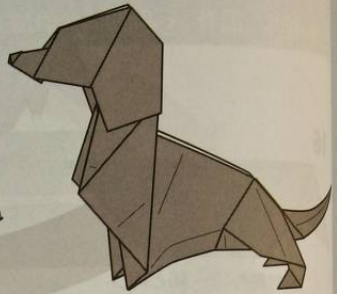

33

内側へ段折り



32

反対側も30~31と同じ

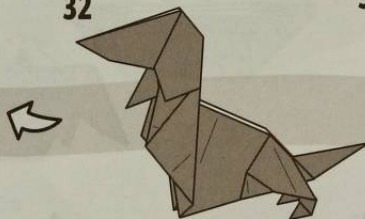

31

中わり折り



27

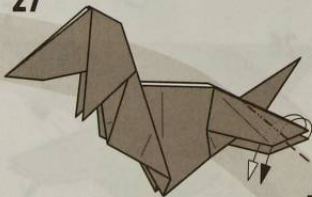

28

段折り



29

反対側も同じ

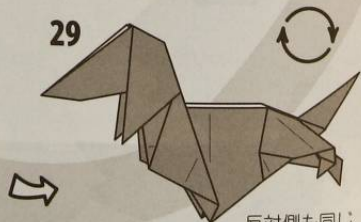

30

折りすじをつける

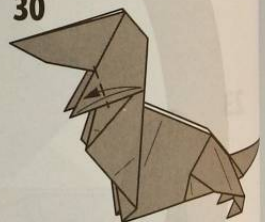

コリー

Collie

作 / 図 渡辺 大
Model and Diagrams by Dai Watanabe

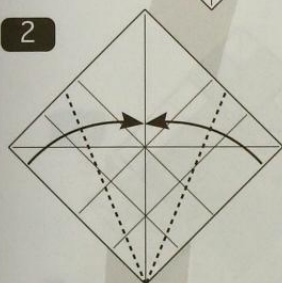
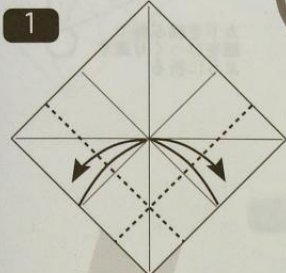
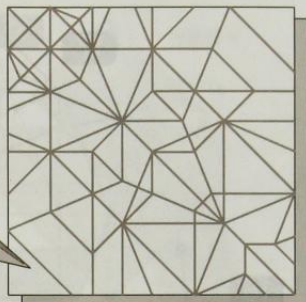
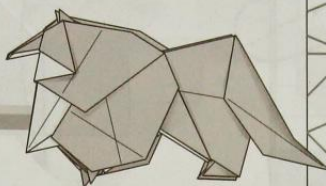

—ご参考までに：用紙の選択—

インサイドアウト作品なので、できれば表裏別色の紙を使ってください。
用紙サイズは通常のおりがみ用紙であれば 25cm 四方程度でしょうか。
頭部が厚くなるので小さな紙だと折るのに力が必要です。

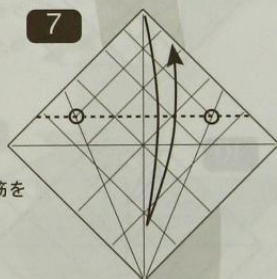
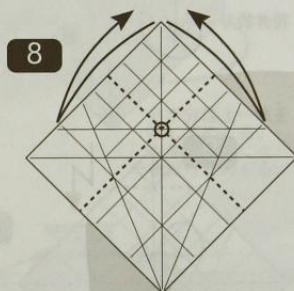
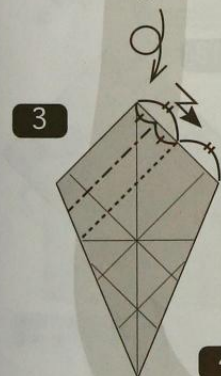

両側についている折り筋を
伸ばすように折る

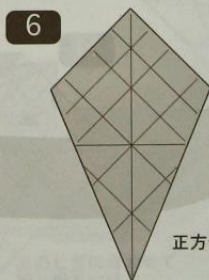

3 の状態に戻す

反対側も
同様に折る

正方形の状態まで戻す

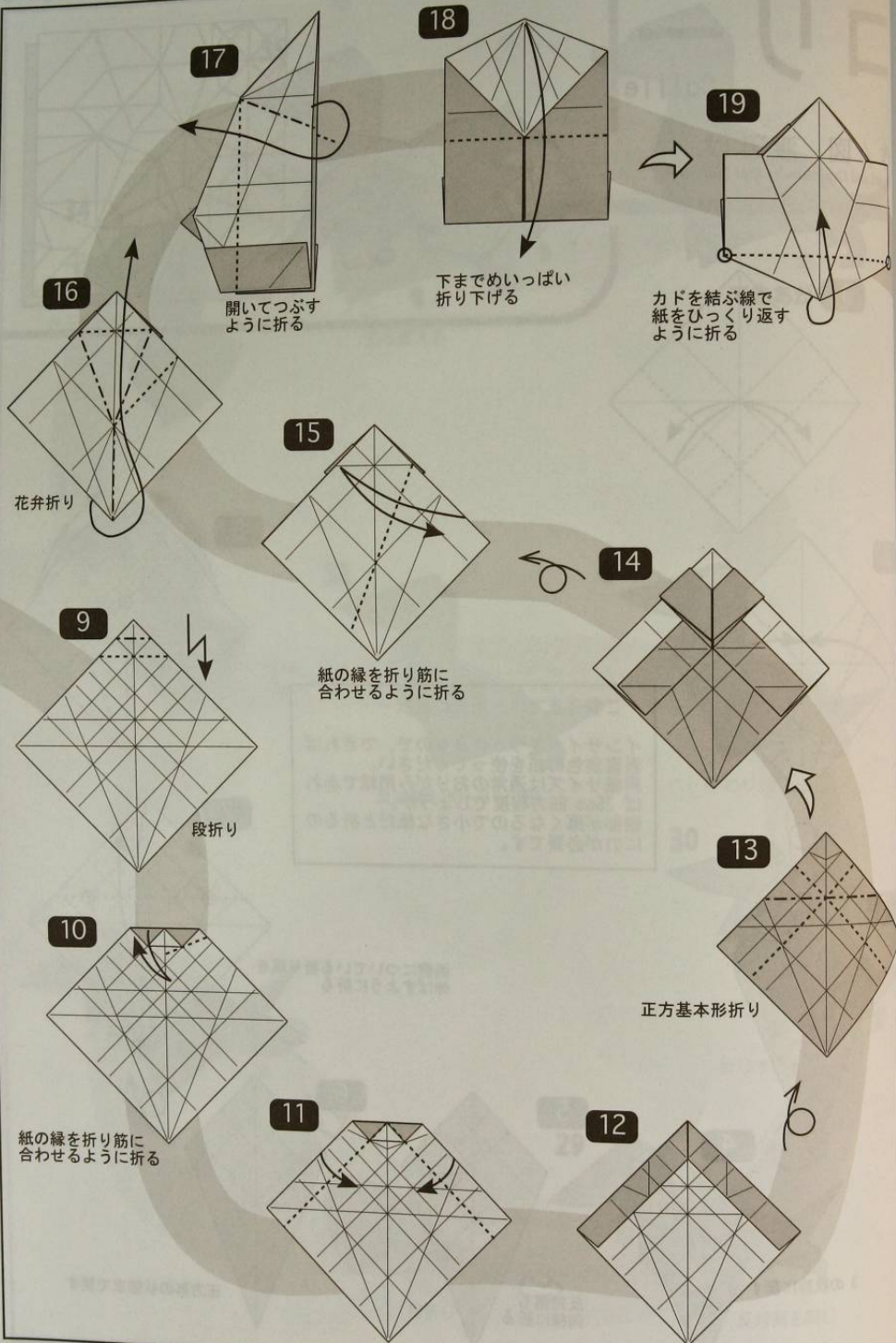

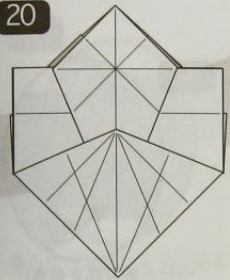

20

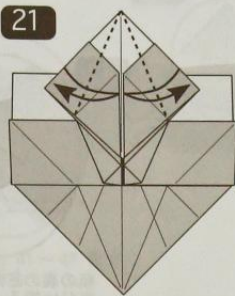

21

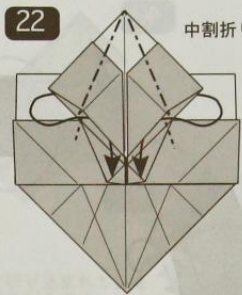

22

中割折り

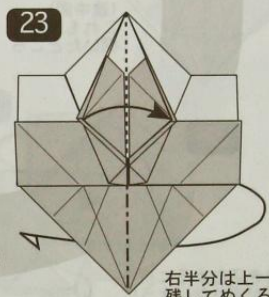

23



右半分は上一枚を残してめくる。
左半分は逆に上一枚だけをめくる。

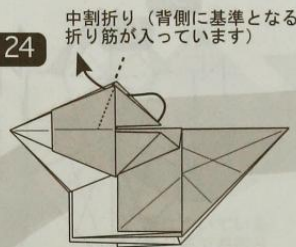

24

中割折り（背側に基準となる折り筋が入っています）

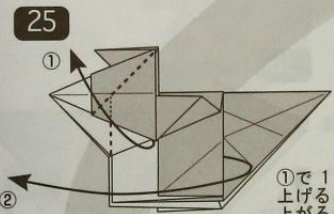

25

①で1番上のヒダを折り上げると②の部分が浮き上がる。浮き上がった部分をそのまま開くように折る

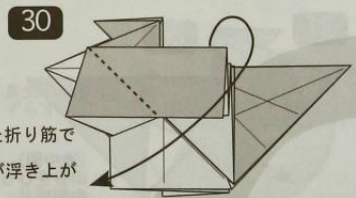

30

28 でつけた折り筋で谷折り（後ろの紙が浮き上がる）

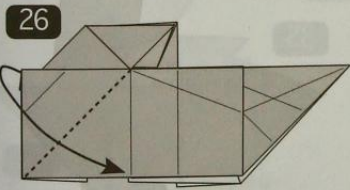

26

裏側の紙の縁に合わせて折る

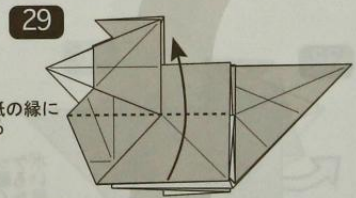

29

裏側にある紙の縁に合わせて折る

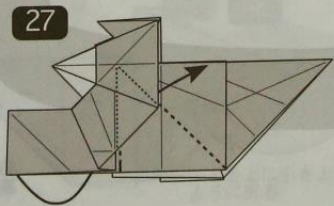

27

山折りの線を背中に合わせるようにして中割折りくっついてくる部分にはなるべく折り筋をつけないように

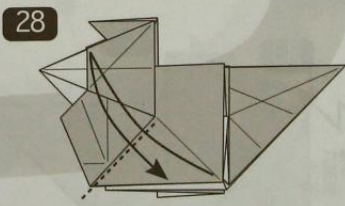

28

上のヒダに合わせて折り筋をつける

40

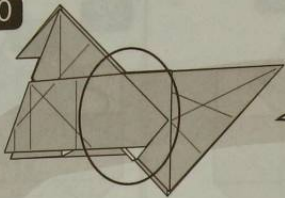

41

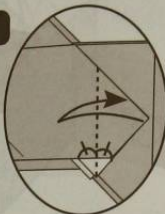

紙の裏の三角形を
半分に分るように
折り筋をつける

42

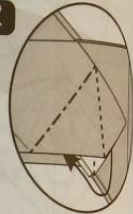

つけた折り筋を参考に
しながらきょうに
折り込む

39



(途中図)
これも腹部を
開いたところ

38

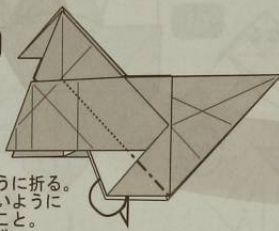

巻き込むように折る。
紙がずれないように
気をつけること。
反対側も同様

37

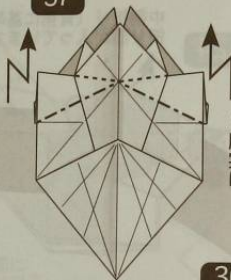

(途中図)
腹部を開いてみたところ。
実際には開きすぎると折り
にくいので注意すること

31

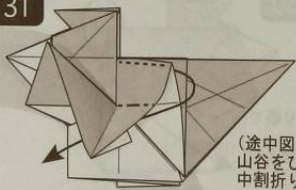

(途中図)
山谷をひっくり返しながら
中割折り

36

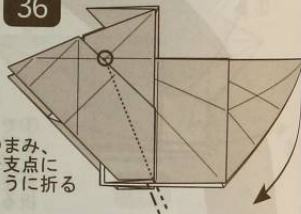

背中部分をつまみ、
○印の部分を中心点に
してずらすように折る

32

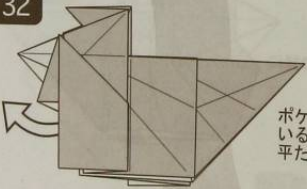

ポケットにしまわれて
いる紙を引き出して
平たく折り潰す

35

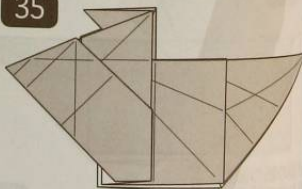

反対側も 25～34 まで
同様に折る

33

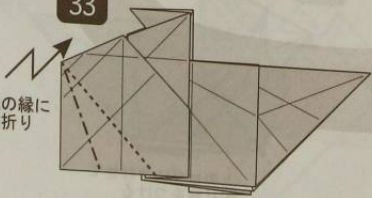

裏にある紙の縁に
合わせて段折り

34

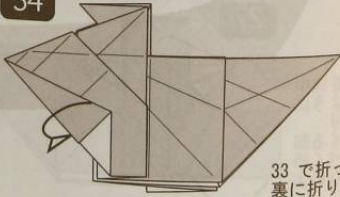

33 で折った部分を
裏に折り返す

45

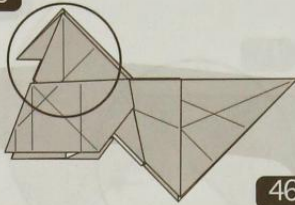

44



反対側も 41～43 まで
同様に折る

43



後ろに巻き込むように折る

46

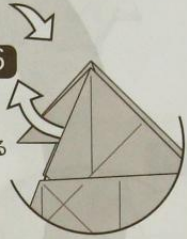

中に折り込まれている
ヒダを引き出す

47

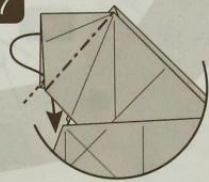

中割折り
折り込んだヒダは内側にある
白いヒダの奥に差し込む

48

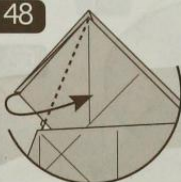

既についている
折り筋で谷折り

49



反対側も 46～48 まで
同様に折る

55

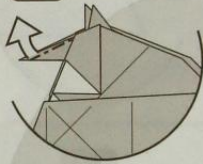

鼻先の紙を少し
ずらす

50

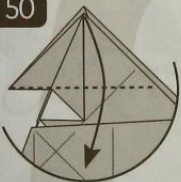

めいっぱい折れる
ところで折り下げる

—ご参考までに—
工程 50～、59～は折り下げ
ないで折った方がきれいに
仕上がります。

54

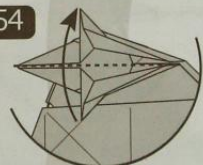

折り下げた部分を
元に戻す

51

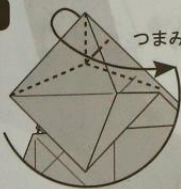

つまみ折り

52

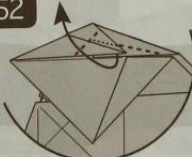

かどを上引き上げる
ように折る

53

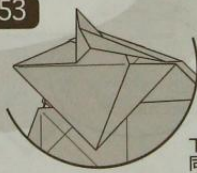

下側も 51～52 と
同様に折る

65

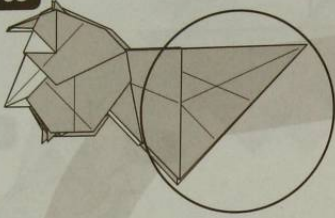

66

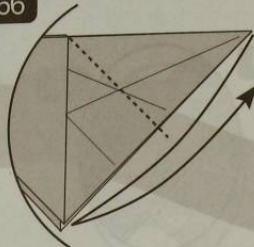

カドを合わせて
折り筋をつける

67

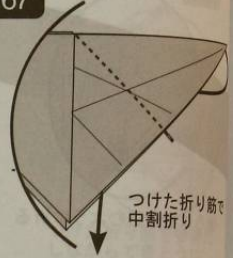

つけた折り筋で
中割折り

64

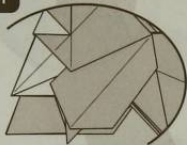

反対側も 59～63 まで
同様に折る

63



中割段折り

62



折り下げた部分を
元に戻し、60 で
引き出した紙の下
に入れる

56

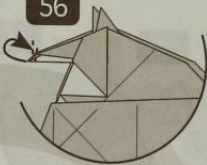

鼻先を中に折り込む

61



ついている折り線に
カドを合わせるよう
にして折る

57

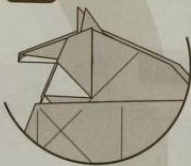

60

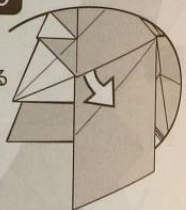

ポケットに
しまわれている
紙を引き出す

58

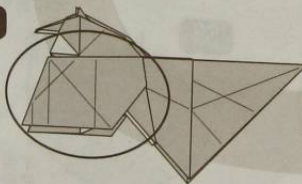

59

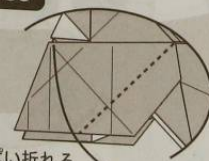

めいっぱい折れる
ところで折り下げる

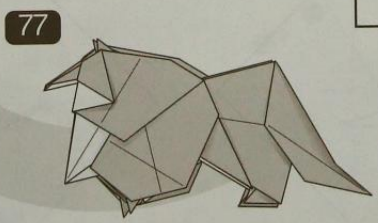
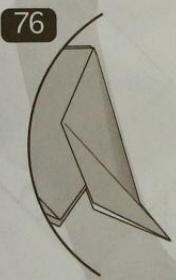
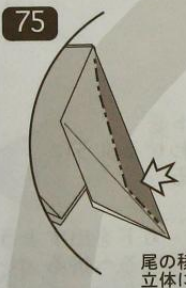
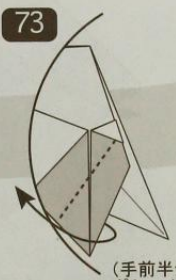
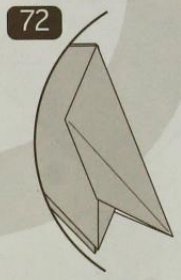
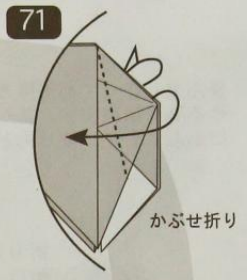
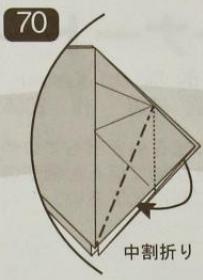
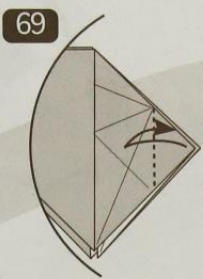
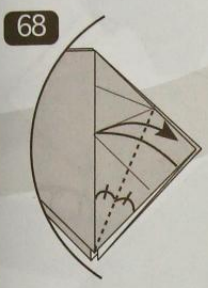

—ご参考までに—

工程 63、73 (足先の仕上げ折り) を省くと走り回るような感じになります。

～セントバーナード～

By Seishi Kasumi
霞 誠志 作：2005.12

畳んでしまっている後ろの方の紙を引き出して口や舌を作る事も出来ます。また、大きな紙で折ると帽子のようにかぶれます。被り物としてご利用下さい。

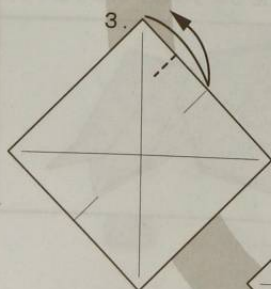
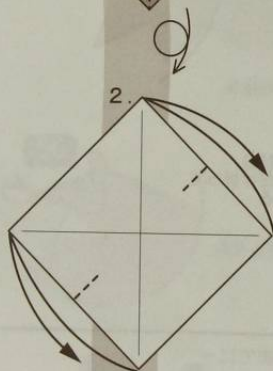
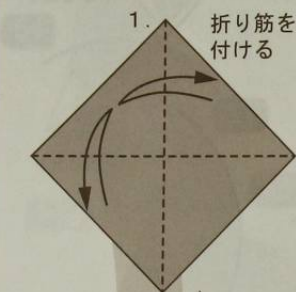
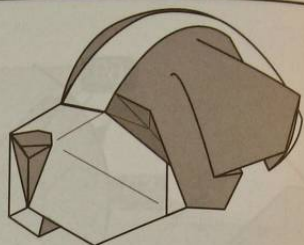

○印を
結ぶ線と
折り筋の
交点に
印を付ける

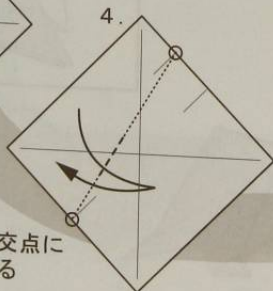

折り筋を
付けたら開く

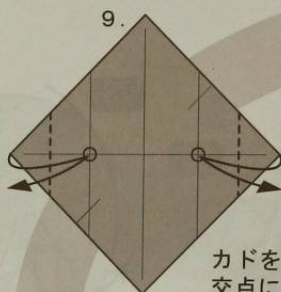
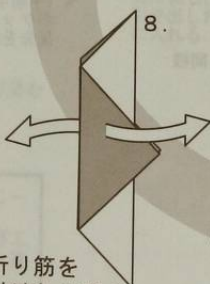

カドを折り筋の
交点に合わせて
折り筋を付ける

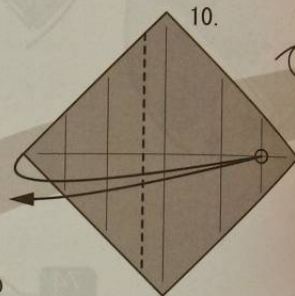

カドを折り筋の交
点に合わせて折り
筋を付ける
反対側も同じ

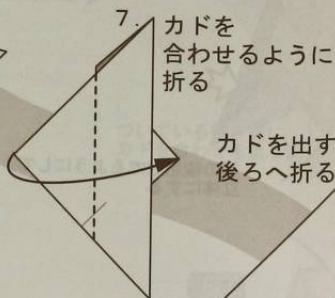

カドを出すようにして
後ろへ折る

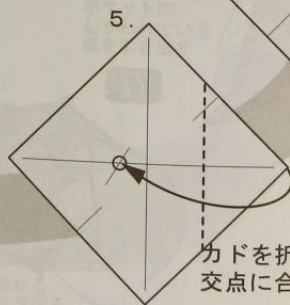

カドを折り筋の
交点に合わせて折る

11. (2で付けた) 折り筋に
カドを合わせて折る

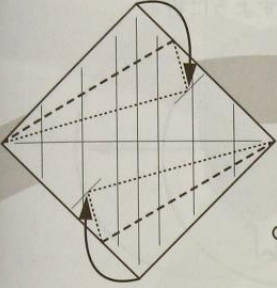

12. ○印を結ぶ線で折る

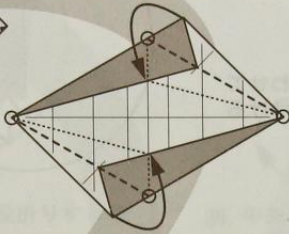

13. フチを合わせるように
して半分に折る

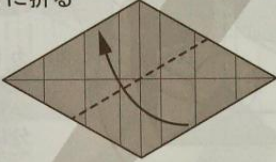

14. 折り筋を付けたら元に戻す
反対側も13と同様に折る

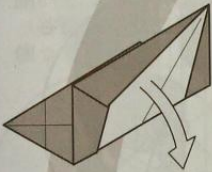

15. フチを折り筋に合わせて折り筋を付ける
反対側も同じ

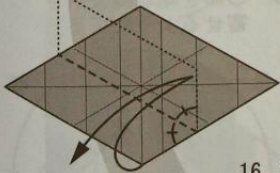

16. 半分の幅で折り筋を付ける

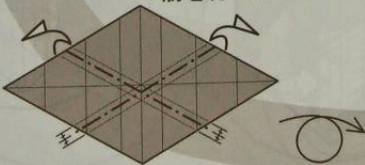

21. フチを折り筋に合わせて折り筋を付ける
反対側も同じ

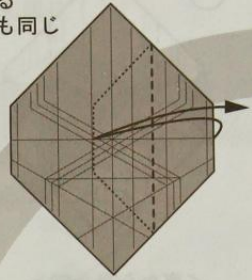

20. カドを19で付けた
折り筋の交点に合わせて折る

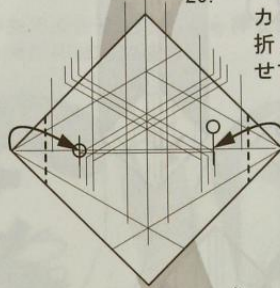

19. カドを折り筋の
交点に合わせて
印を付ける
反対側も同じ

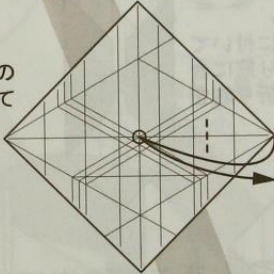

18. 谷折線を山折
に折り返る

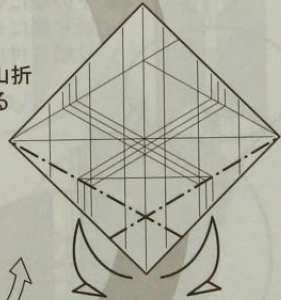

17. カドを折り筋の交点
に合わせて折り筋を
付けたら全て開く

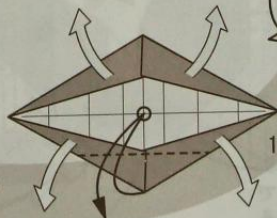

22. すでにある折り筋で折る

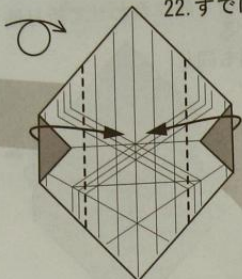

31. (谷折線=18で付けた折り筋) 開いてつぶすように折る

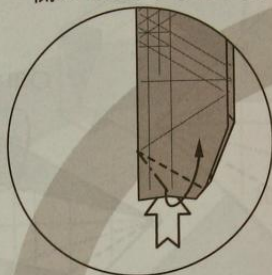

23. フチに合わせて折り筋を付ける

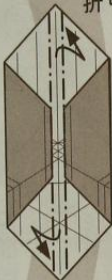

<裏から見た図>

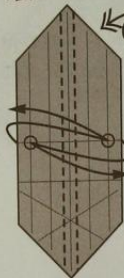

30. カドを小さく後ろに折ってから全体を半分に折る



24. 下の紙に付いている折り筋に合わせて折り筋を付ける



29. フチを折り筋の交点に合わせて折る

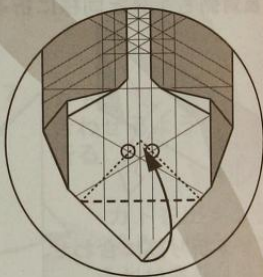

25. 下の紙に付いている折り筋に合わせて折り筋を付ける

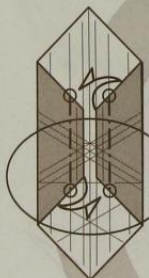

28. ○印を結ぶ線で引き寄せるように折る

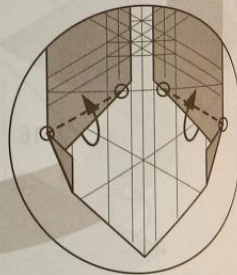

27. フチを折り筋に合わせて折る

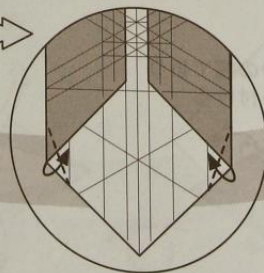

26. ○印を結ぶ線で折り筋を付ける

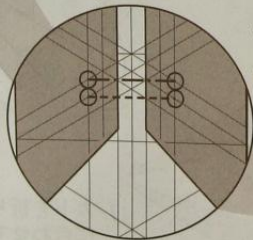

32. 折り筋を付けたら
一旦開く

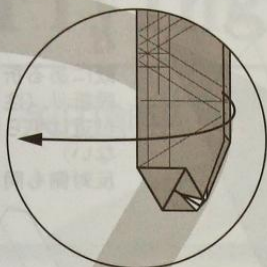

33. 図のような折り筋で段折りする

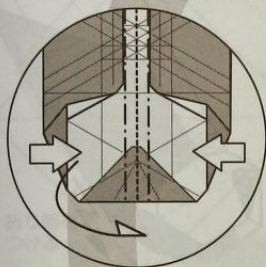

34. 開いてつぶすように折る
(谷折線は既にある折筋を
使って折る)

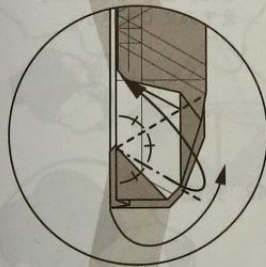

35. 折り筋を付けたら一旦
開く

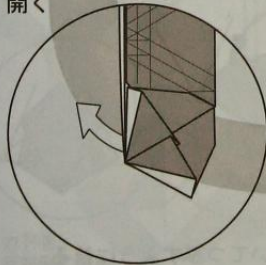

36. 図のような折り筋で
たたみ直す

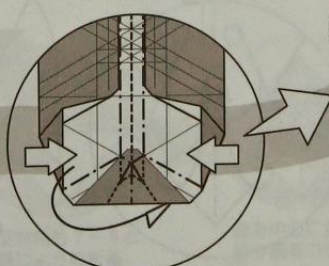

40. カドを後ろに折る
反対側も同じ

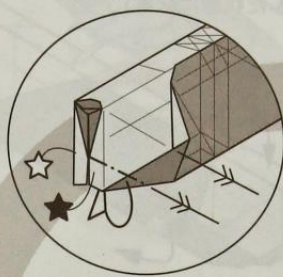

39. 中央の段折りを後ろから押し出して立体化する
☆☆印の位置に注意



[透視図]

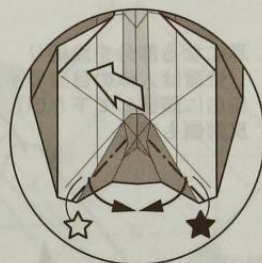

[正面から見た図]

38.

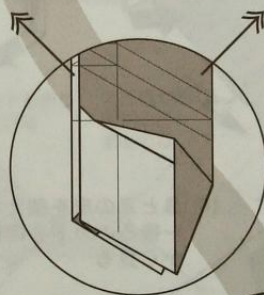

37. [途中図]

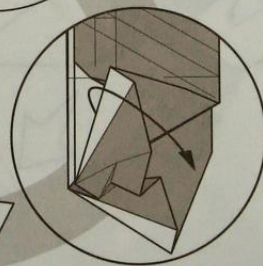

41. 次図のようにカドを立ち上げる
(この時、☆印のフチの部分
はたわんだ状態になる)

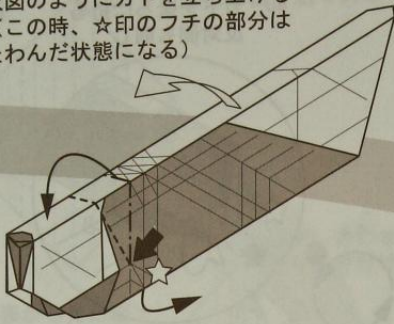

43.
既にある折り筋で
段折り (注: 目の
付近は平らになら
ない)
反対側も同じ

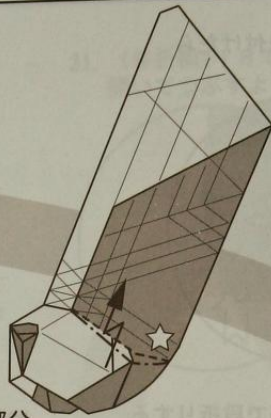

42.
たわんでいる部分
が平らになるよう
に段折り
反対側も同じ

45. 耳になる部分を段折り
(位置は大体の目安です
自由に調整して下さい)
反対側も同じ

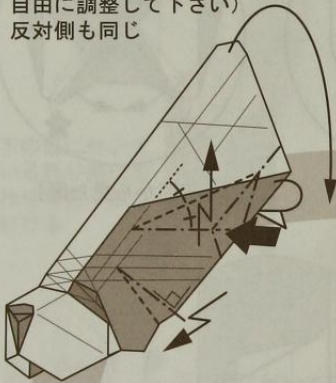

作者より: 体の方は、
(未だに) 出来ていま
せん。皆さんで体は考
えてみてください。



44.
後ろへ折る
反対側も同じ

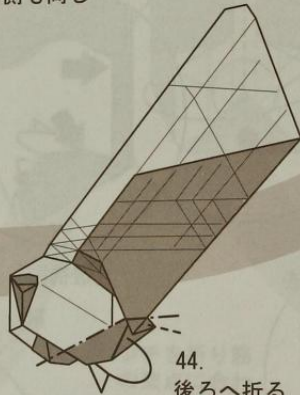

46. 鼻と耳の形を整える
～後ろのカドを内側
から見る

49. 完成



47. 既にある折筋を使
ってつまみ折り

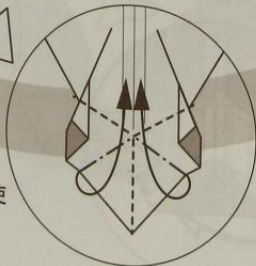

48. 開いてつぶすように折る

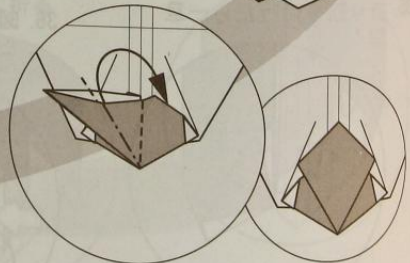

Flying Pig

永田創平 作・2005/11/23
図・2006/6/10

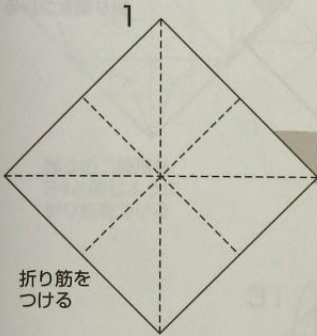
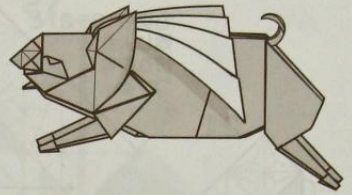

1
折り筋をつける

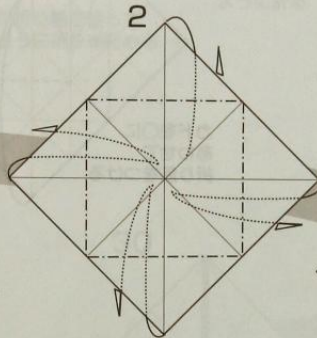

2
折り筋をつける

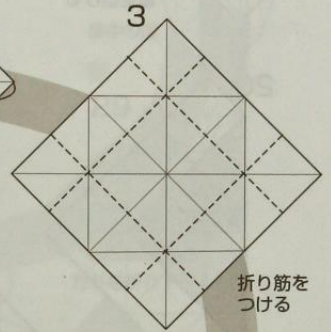

3
折り筋をつける

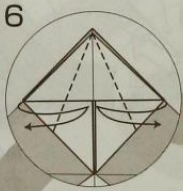

4
折り筋をつける

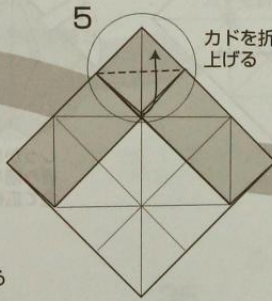

5
カドを折り上げる

正方基本形の要領で折りまとめる

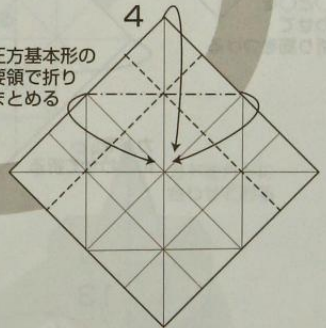

6
折り筋をつける

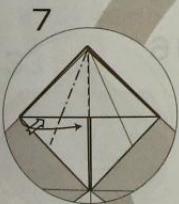

7
内側をひろげてつぶすように折る

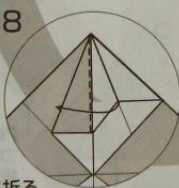

8
カドを反対側に折る

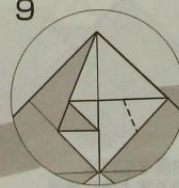

9
反対側も7~8と同じように折る

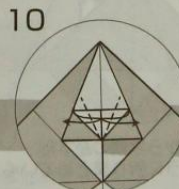

10
縁を中心に合わせて折り筋をつける

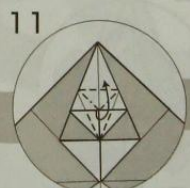

11
花弁折り

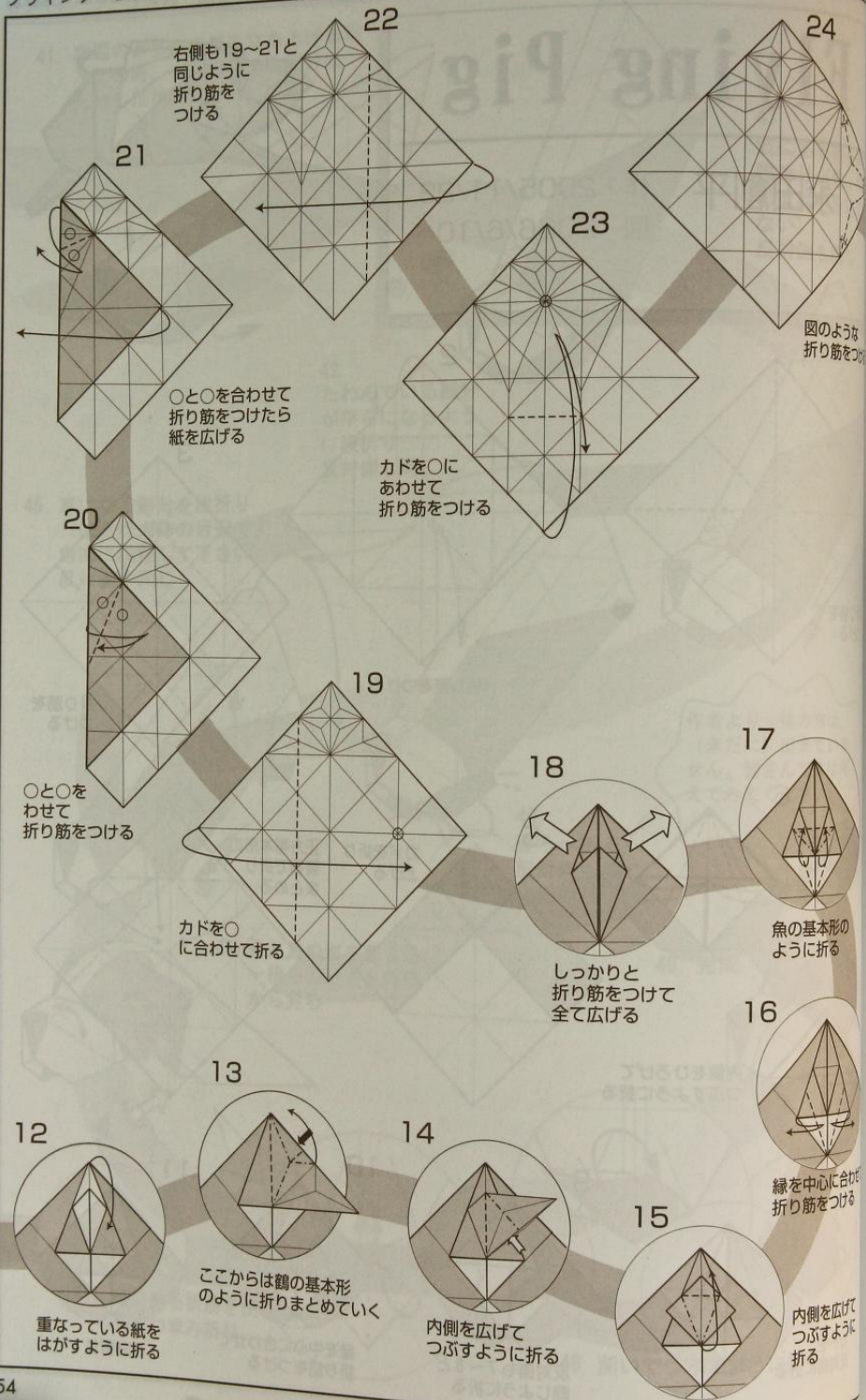

右側も19~21と
同じように
折り筋を
つける

○と○を合わせて
折り筋をつけたら
紙を広げる

カドを○に
あわせて
折り筋をつける

図のよう
折り筋をつ

○と○を
わせて
折り筋をつける

カドを○
に合わせて折る

しっかりと
折り筋をつけて
全て広げる

魚の基本形
のように折る

ここからは鶴の基本形
のように折りまとめていく

内側を広げて
つぶすように折る

内側を広げて
つぶすように
折る

重なっている紙を
はがすように折る

残
24
折

32
カドを
折り筋

33
カドをつ
折り筋で

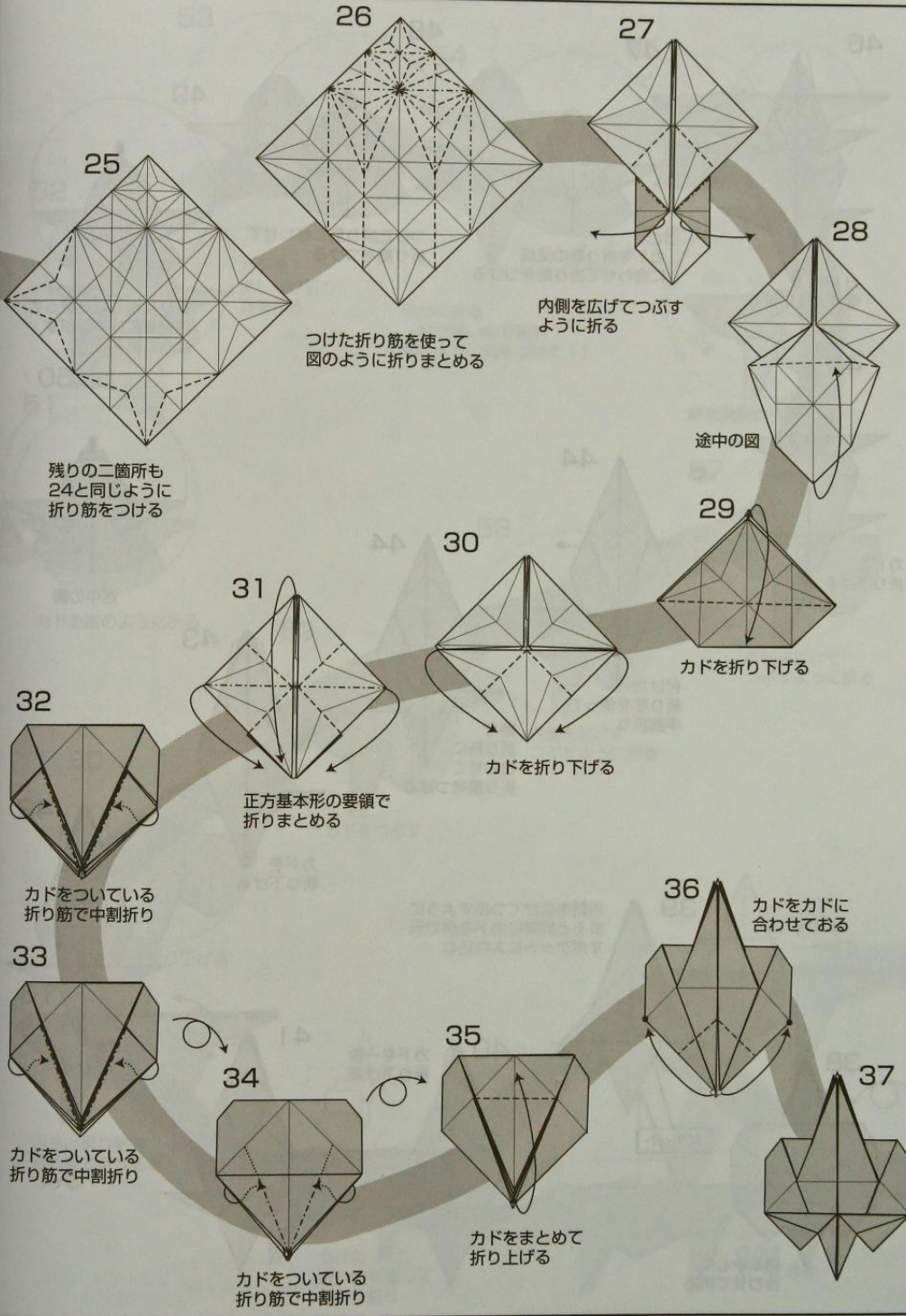

25

残りの二箇所も
24と同じように
折り筋をつける

26

つけた折り筋を使って
図のように折りまとめる

27

内側を広げてつぶす
ように折る

28

途中の図

29

カドを折り下げる

30

カドを折り下げる

31

正方基本形の要領で
折りまとめる

32

カドをついている
折り筋で中割折り

33

カドをついている
折り筋で中割折り

34

カドをついている
折り筋で中割折り

35

カドをまとめて
折り上げる

36

カドをカドに
合わせておる

37

46



カドを
巻くように折る

47

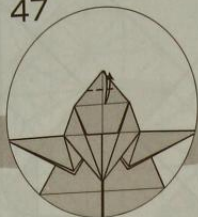

カドを折り筋の交点
に合わせて折り筋をつける

48

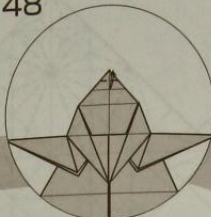

つけた折り筋に合わせて
折り筋をつける

49



つけた折り筋を使って
内側を広げてつばす
ように折る

45

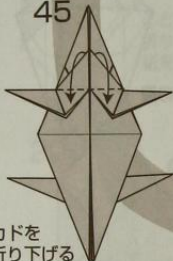

カドを
折り下げる

44

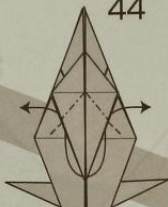

付けた
折り筋を使って
中割折り

44



縁を
折り筋に
合わせて
折り筋をつける

43

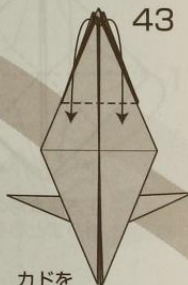

カドを
折り下げる

50



途中の図

39

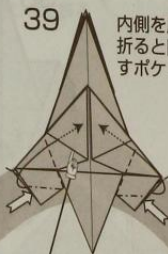

内側を広げてつばすように
折ると同時にカドを円で示
すポケットに入れ込む

38

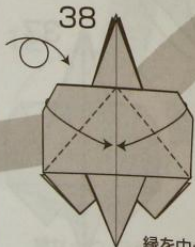

縁を中心に
合わせて折る

40



カドを一枚
折り下げる

41

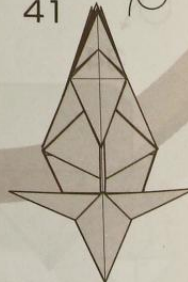

カドを
折り下げる

42



52



51



カド

61



ふち
合わせ
つけ

53

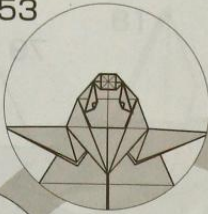

54



55

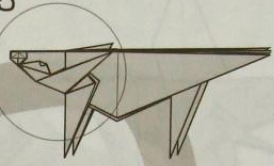

52

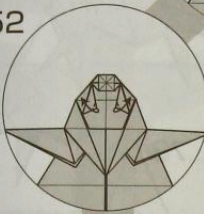

カドを
少しだけ折り
目を作る

半分に折る
(紙が厚いので破れ
ないように気をつけて!)

56

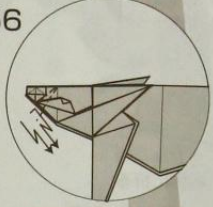

鼻を両側から段折り

51



カドを図のように折る

58

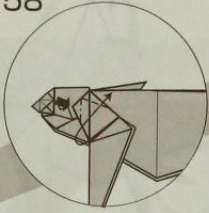

内側を広げて
つぶすように折る

57

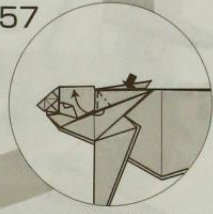

内側を広げて
つぶすように折る

59

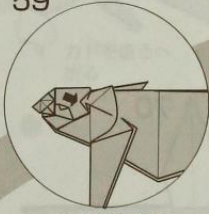

カドをつぶす

60

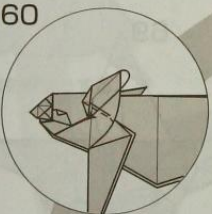

カドを折り下げる

64

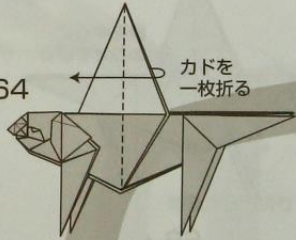

カドを
一枚折る

61



ふちと折り筋を
合わせて折り筋を
つける

62

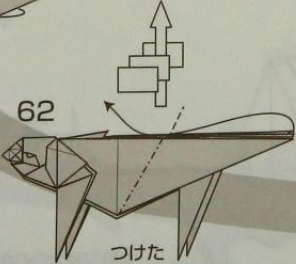

つけた
折り筋を使って
中わり折り

63

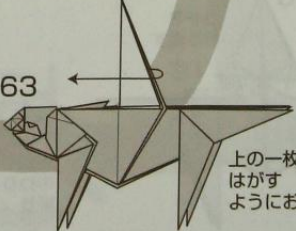

上の一枚を
はがす
ようにおる

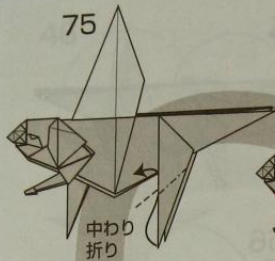

75

中わり
折り

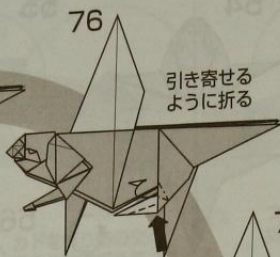

76

引き寄せる
ように折る

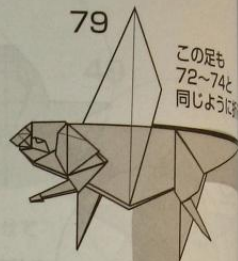

79

この足も
72~74と
同じように折る

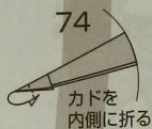

74

カドを
内側に折る

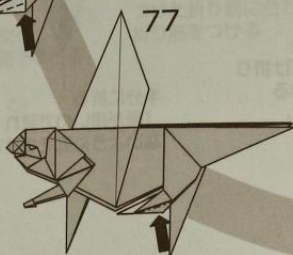

77

反対側も76と
同じように折る

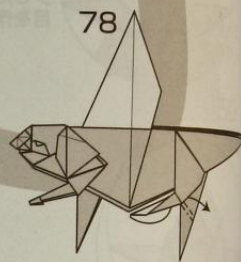

78

中わり折り



73

足を細くする
ように折る



72

かぶせるように
両側から段折り

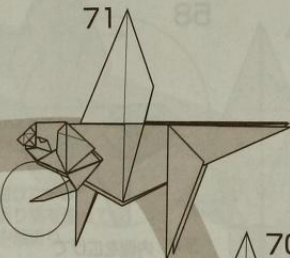

71

70



65

縁を中心に
あわせておる

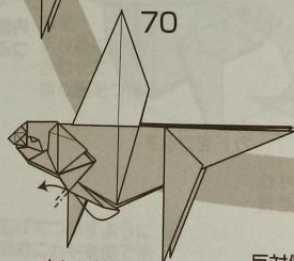

70

中わり折り

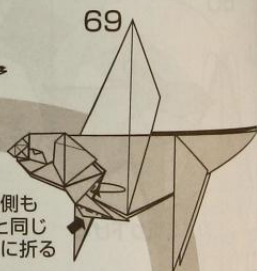

69

反対側も
68と同じ
ように折る

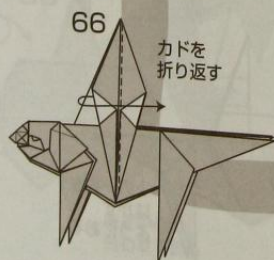

66

カドを
折り返す

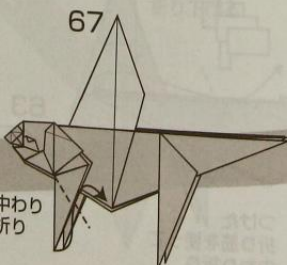

67

中わり
折り



68

足を細くする
ように
引き寄せ折り

80

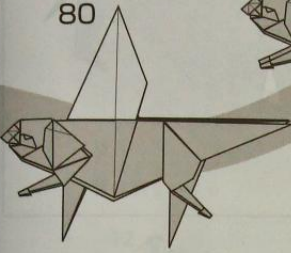

反対側も57~79と
同じように折る

81

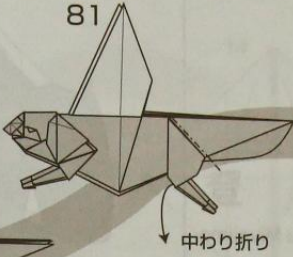

中わり折り

82



カドを折る

83

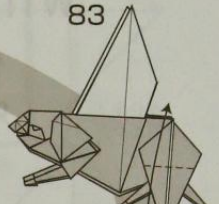

カドを
折り上げる

84

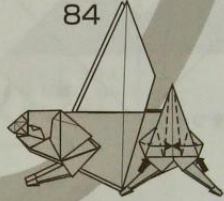

引き寄せるように折る

86

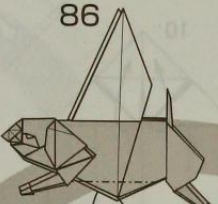

カドを後ろへ
折る

85

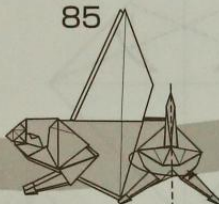

カドを折り返す

87



羽を段折りする

88

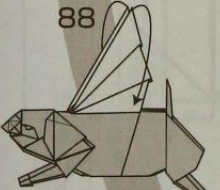

曲線を描くように
羽を折る

94

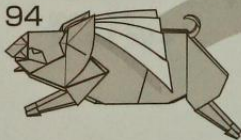

できあがり

93

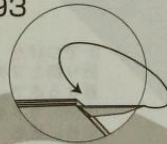

尾をカールさせる

92



両側から段折り

89

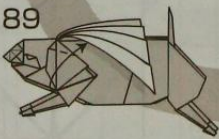

耳を工程60の状態に戻す
反対側も同じように折る

90

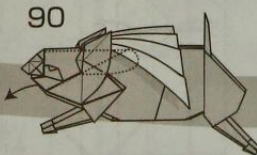

中わり折りで口を出す

91

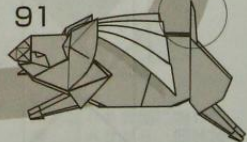

いのしし

Wild Boar

作/図 宮島 登

Design & Diagrams By Noboru Miyajima

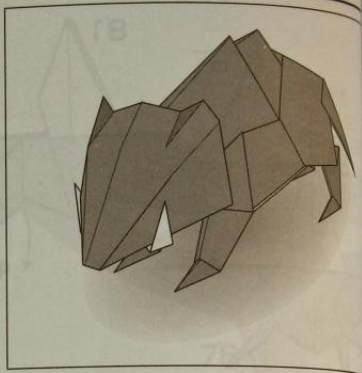

創作 2003年1月
作図 2006年6月

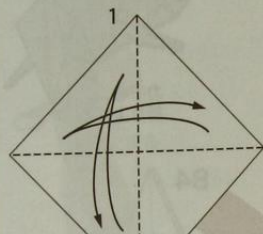

折り筋をつける

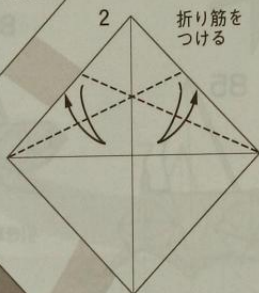

折り筋をつける

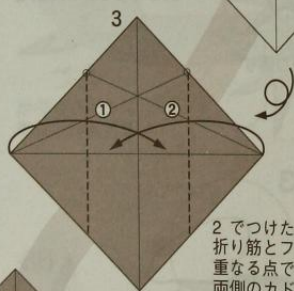

2 でつけた折り筋とフチが重なる点で、両側のカドを順番に折る

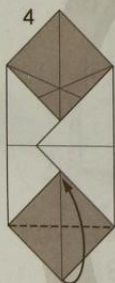

フチを合わせるように折る

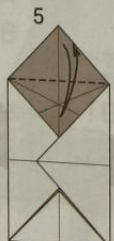

折り筋をつける



折り筋をつける

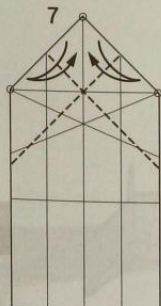

○印を合わせて折り筋をつける



すでについている折り筋で正方形基本形の要領でまど

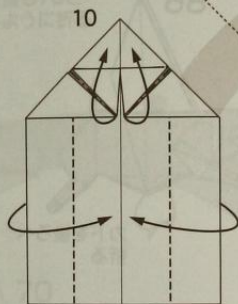

2つのカドを持ち上げながら、両端をたたむ。

正方形の部分を後ろに折り返す

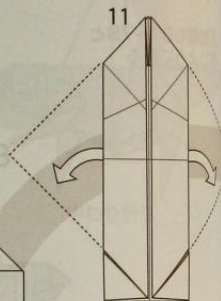

後ろに折られている部分を開く

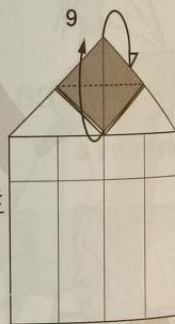

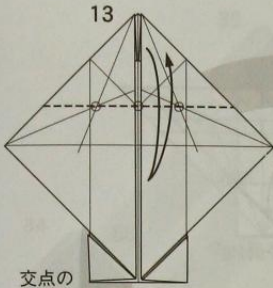

13
交点の
○印を通る線で
折り筋をつける

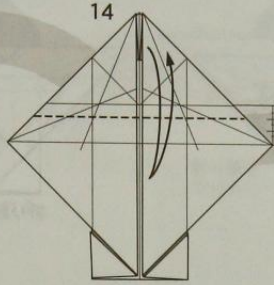

14
1/3 のところで
折り筋をつける

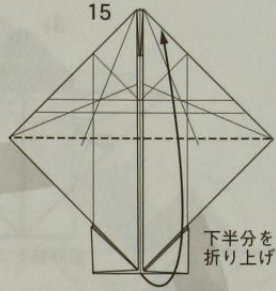

15
下半分を
折り上げる

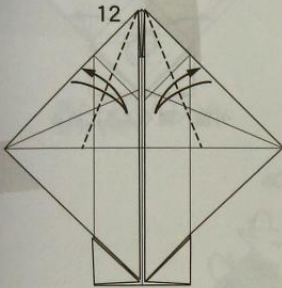

12
折り筋をつける

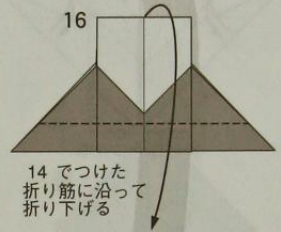

16
14 でつけた
折り筋に沿って
折り下げる

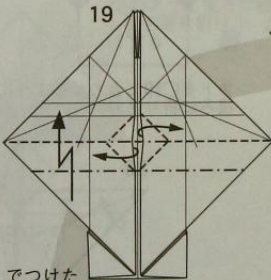

19
18 でつけた
折り筋で中わり折りしながら
全体を段折りする

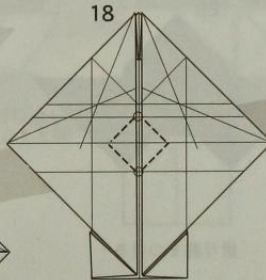

18
図のような
折り筋をつける

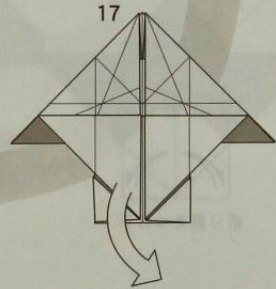

17
戻す

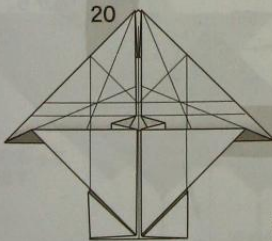

20
【途中図】

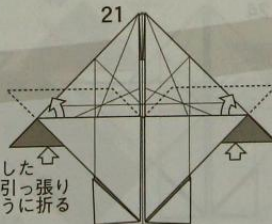

21
段折りした
部分を引っ張り
出すように折る

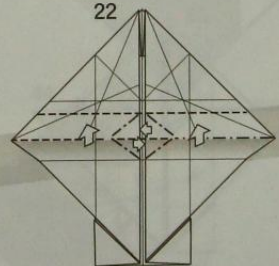

22
【途中図】
中心部分を外側に向けて
押し込みながら、凹状部
分を引き上げる

31

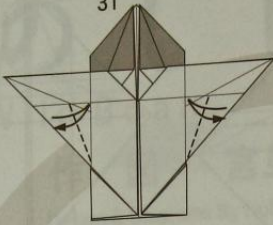

折り筋をつける

32

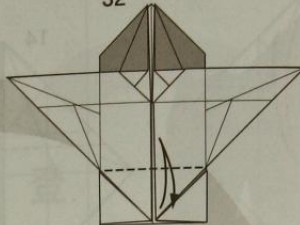

折り筋をつける

33

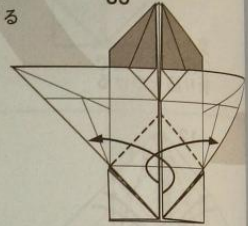

外側へ開くように折る

30

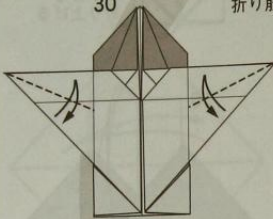

折り筋をつける

29

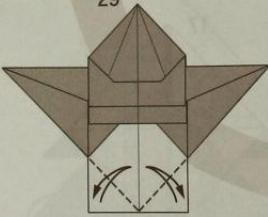

折り筋をつける

28

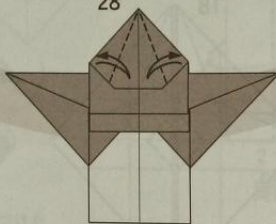

折り筋をつける

27

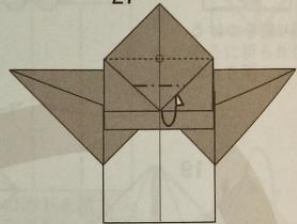

カドを○印に合わせるように後ろに折り込む

26

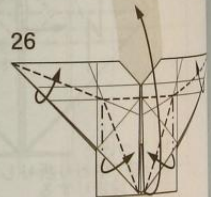

すでについている折り筋フチを折りながら、カドを折り上げる

23

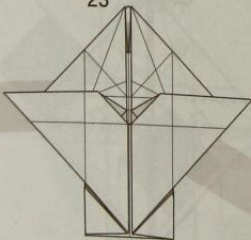

[途中図]

24

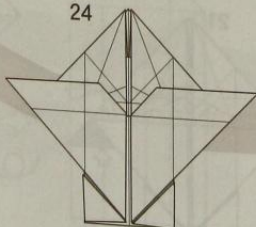

25

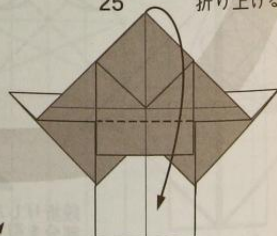

カドを折り下げる

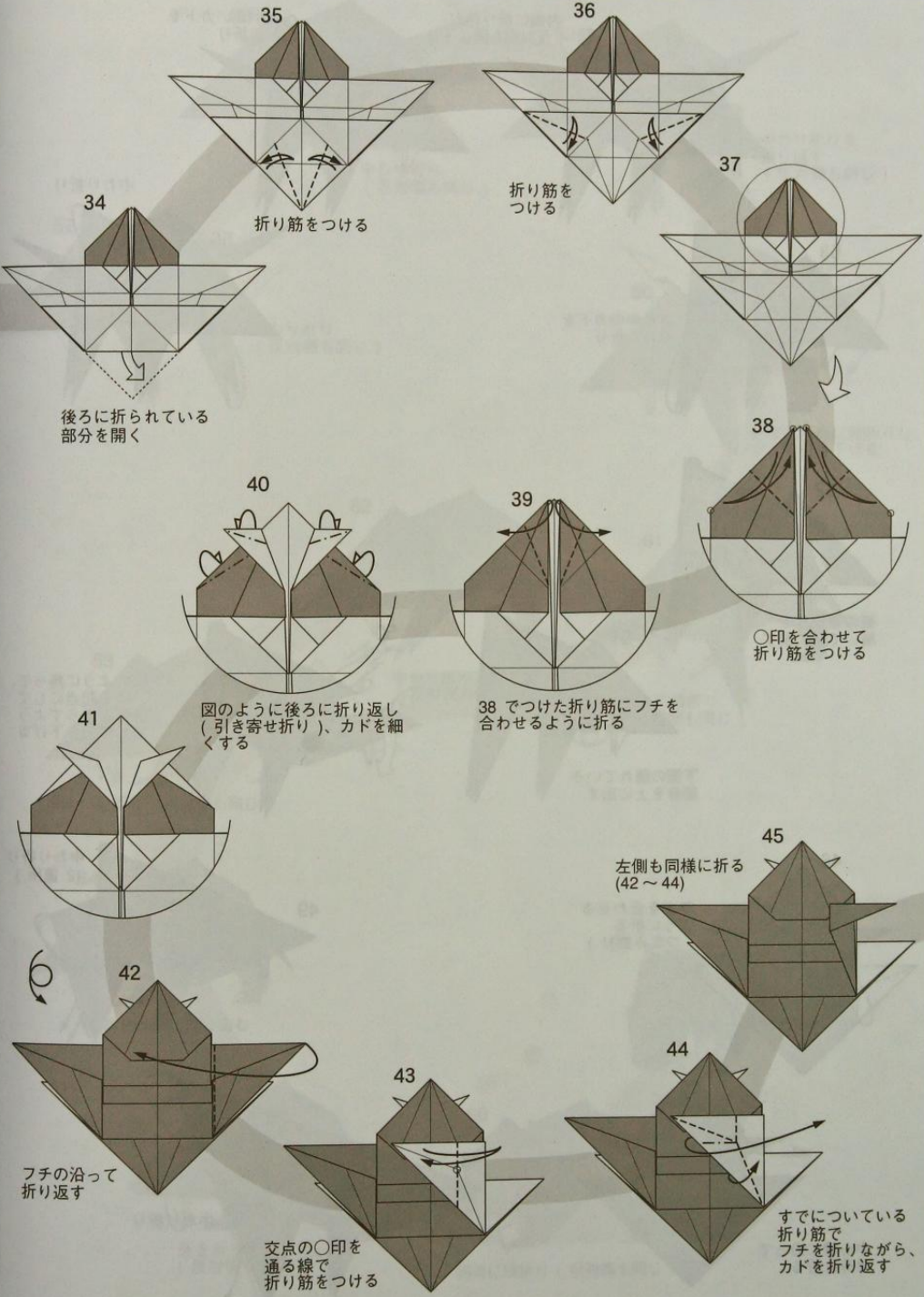

35 折り筋をつける

36 折り筋をつける

37

34

後ろに折られている部分を開く

40

39

38

○印を合わせて折り筋をつける

41

図のように後ろに折り返し(引き寄せ折り)、カドを細くする

38 でつけた折り筋にフチを合わせるように折る

45 左側も同様に折る(42~44)

6

42

フチの沿って折り返す

43

交点の○印を通る線で折り筋をつける

44

すでについている折り筋でフチを折りながら、カドを折り返す

54

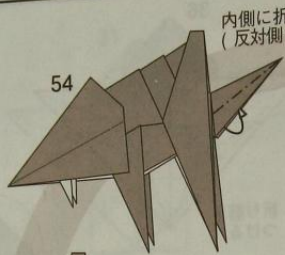

内側に折り込む
(反対側も同じ)

55



小さいカドを
谷折り

53

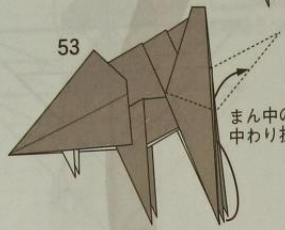

まん中のカドを
中わり折り

中わり折り

56

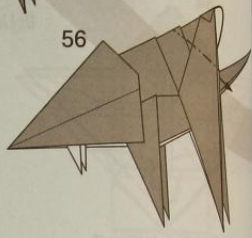

52



紙の重なりを
解いて元に戻す

51

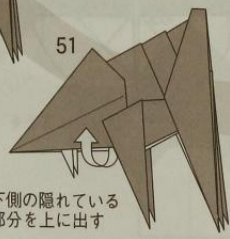

下側の隠れている
部分を上に出す

50

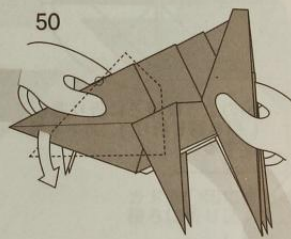

図のように持つて
○印を起点にして
頭部をずらすように
にして引き下げ

46

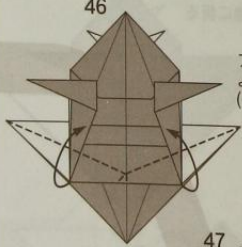

フチを合わせる
ように折る
(つまみ折り)

中わり折
(2箇所)

49

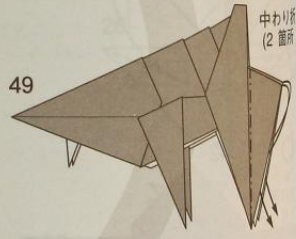

47

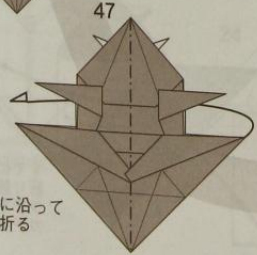

中心線に沿って
半分に折る

48

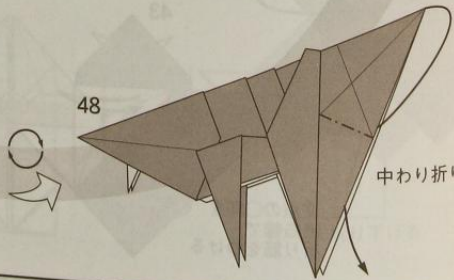

中わり折り

58

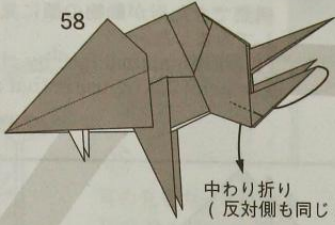

中わり折り
(反対側も同じ)

59

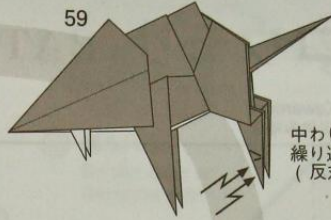

中わり折りを
繰り返す
(反対側も同じ)

57

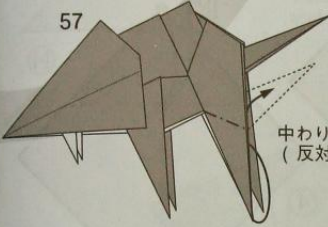

中わり折り
(反対側も同じ)

60

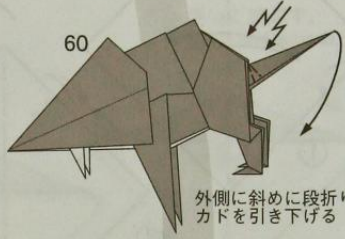

外側に斜めに段折りし、
カドを引き下げる

62

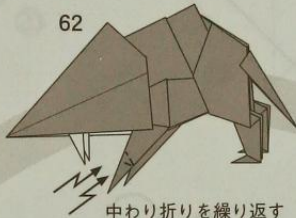

中わり折りを繰り返す
(反対側も同じ)

61

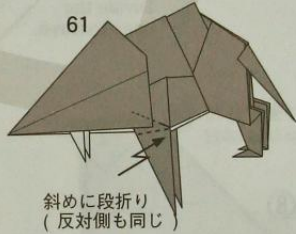

斜めに段折り
(反対側も同じ)

63

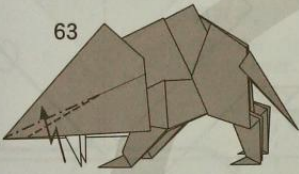

斜めに段折り (反対側も同じ)

64

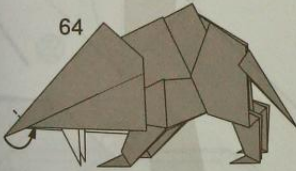

先端を内側に折り込む

67

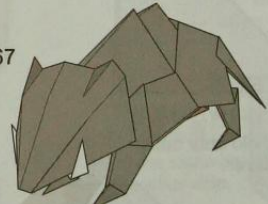

できあがり

65

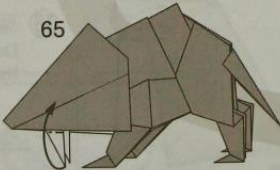

牙を折り上げる
(反対側も同じ)

66

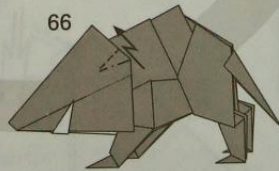

斜めに段折り (反対側も同じ)

偶然できた形が動物の顔に見えたのでコウモリ
してみました。
I made an animal face by chance and designed
a origami bat by using that shape.



コウモリ / BAT

©2006 Miyuki Kawamura
川村みゆき

①

② 3等分。
Divide the edge to three.

③

④

⑤

⑥

⑦

⑧ 上の角だけ折る。
Fold only upper layer.

⑨ 上の角だけ折る。
Fold only upper layer.

⑩ 折ったら開く。
Unfold back to the step ⑦.

⑪

⑫ 反対側も同じ。
Do the same on the other side.

⑬ 反対側も同じ。
Do the same on the other side.

⑭

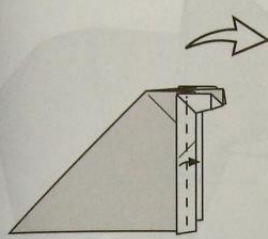

14

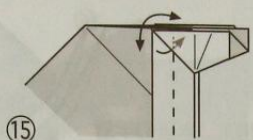

15 耳の先をカールさせる。
Tuck the flap into the ear
and make a curved shape.

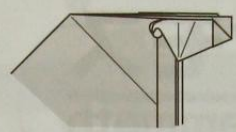

16 裏も同じ。
Do the same on
the other side.

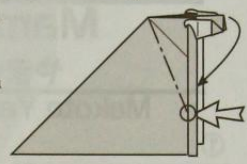

17 開いてつぶす。
Open and squash.

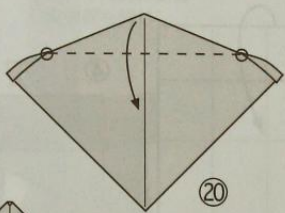

20

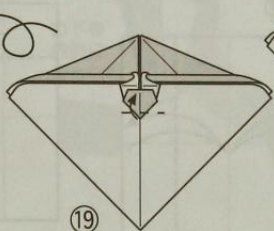

19

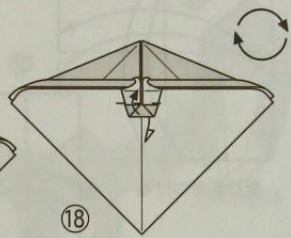

18

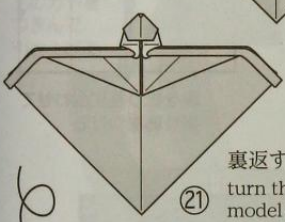

21 裏返す。
turn the
model over.

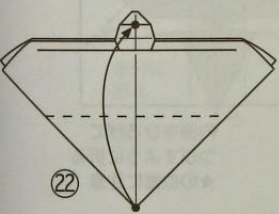

22



29 折り目をつける。
Fold and unfold.

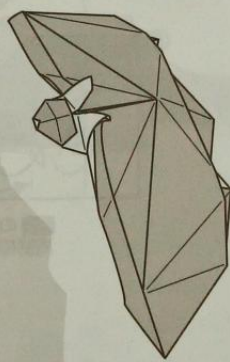

「コウモリ」
BAT

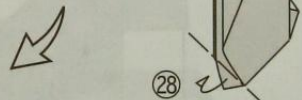

28 反対側も同じ。
Do the same on
the other side.

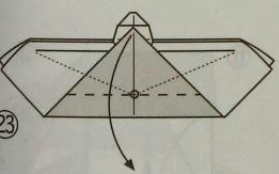

23

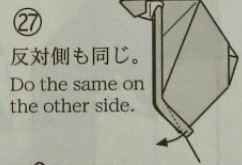

27 反対側も同じ。
Do the same on
the other side.

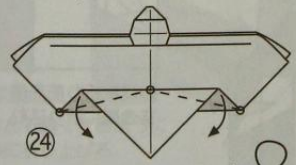

24

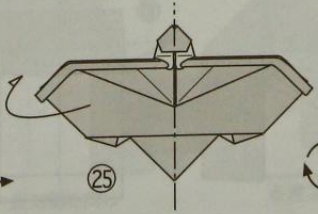

25

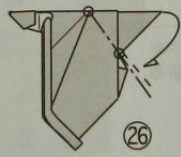

26 中割り折り。
Inside reverse fold.

マンモス

Mammoth

やまぐち 真

Makoto Yamaguchi

10年程前に、学研の学習誌に掲載するために作ったもの。その後は私の本にも使う機会がなかった作品。今回ちょうどページが開いたので、登場する機会に恵まれた。

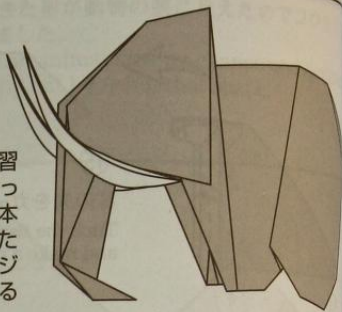

①

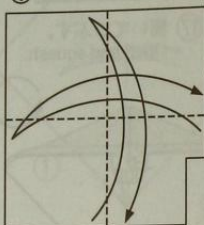

折り筋をつける

②

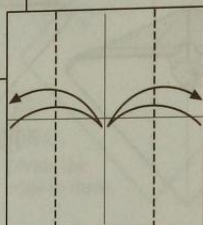

折り筋に合わせて折り筋をつける

③

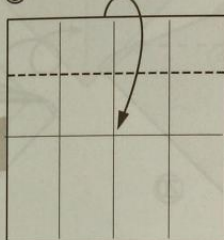

折り筋に合わせて折る

④

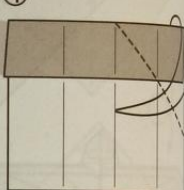

縁を折り筋に合わせて折り筋をつける

⑦

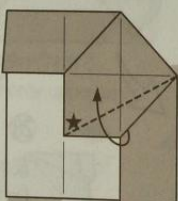

カドとカドを結ぶ線で折る

⑥

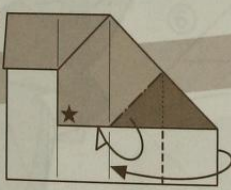

■の部分の内側に折る

⑤

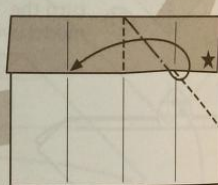

内側をひろげてつぶすように折る
★の位置に注意

⑧

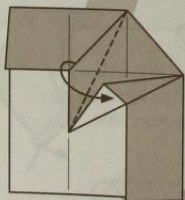

カドとカドを結ぶ線で折る

⑨

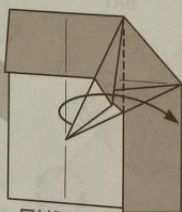

反対側に折る

⑩

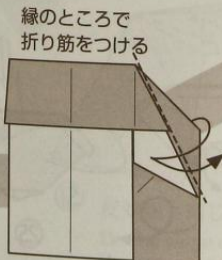

縁のところで折り筋をつける

⑪



つけた折り筋を使ってすき間に折り込む

⑫

つま斜め

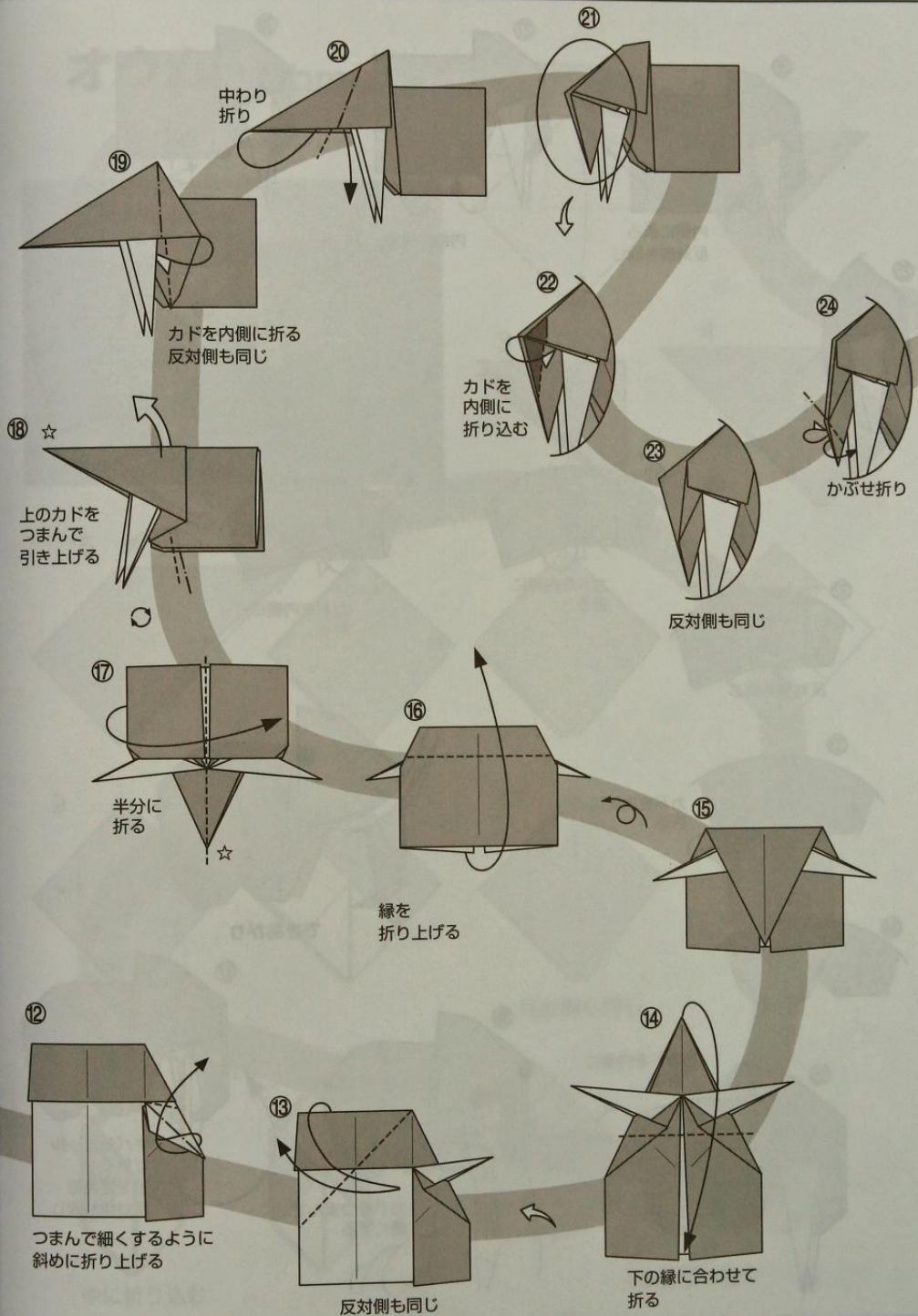

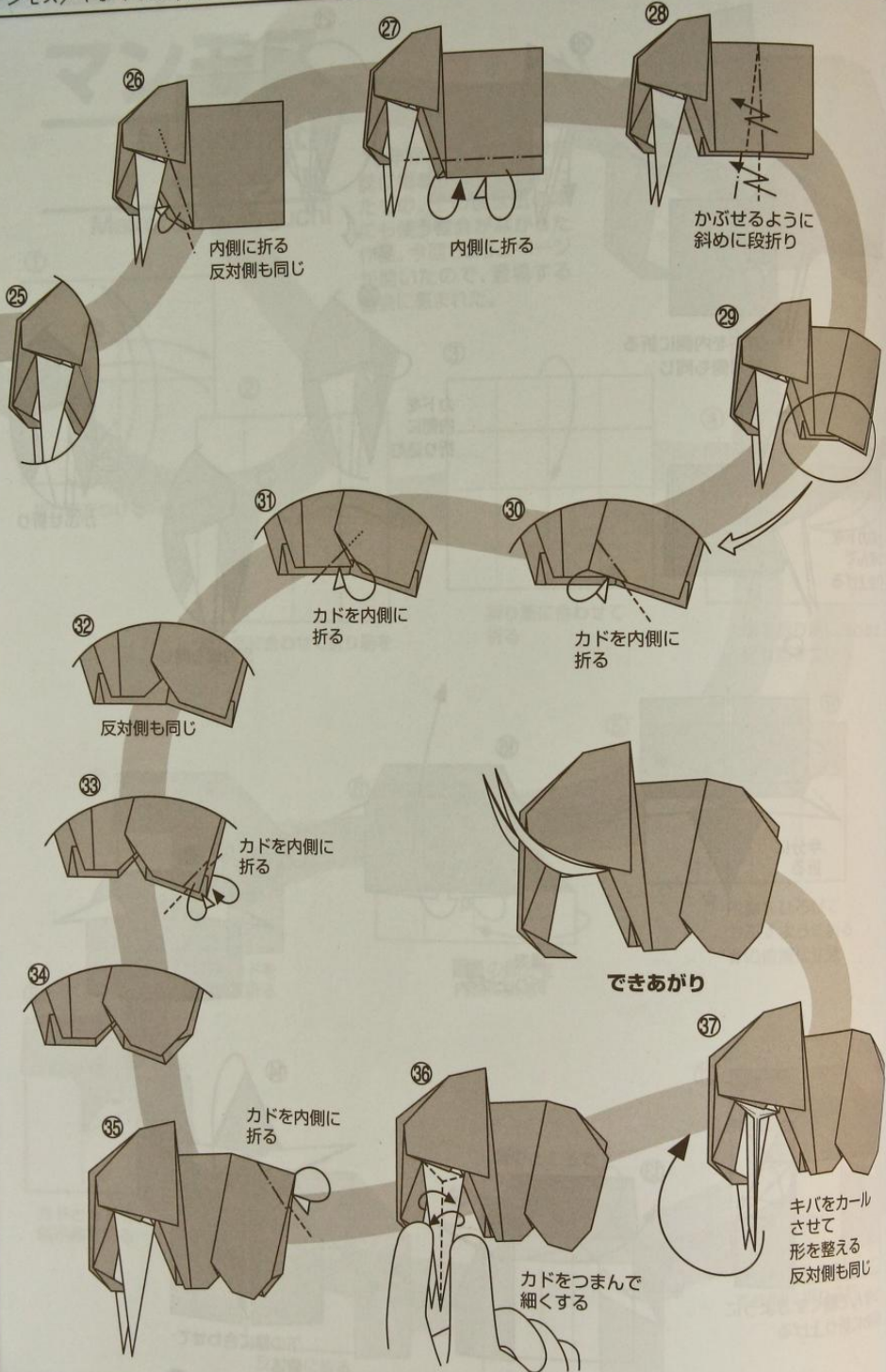

オウム Ohmu

創作者：猪原龍介

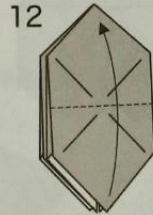
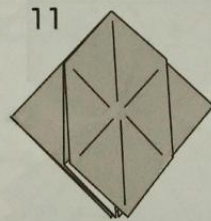
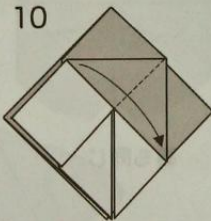
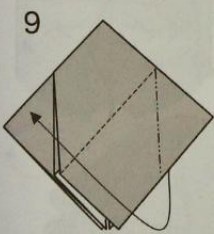
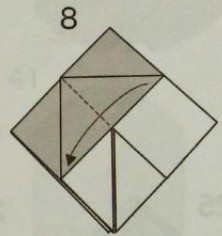
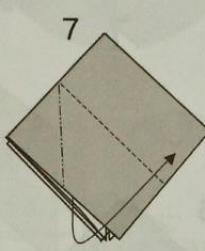
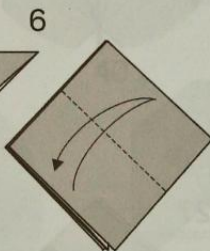
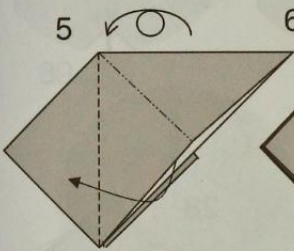
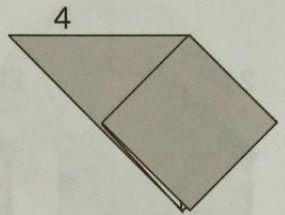
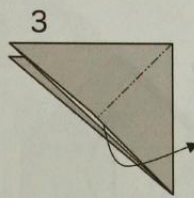
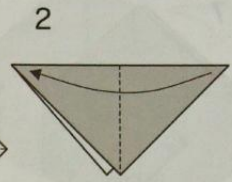
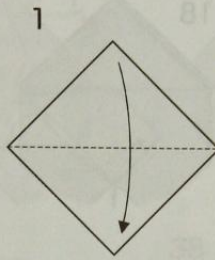
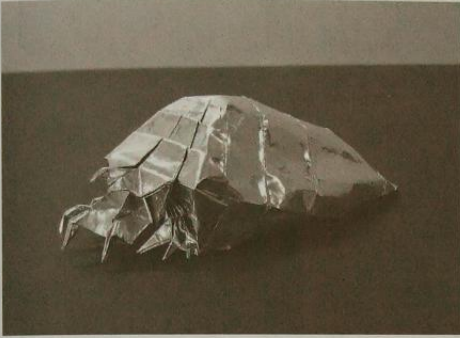

反対側も同じ

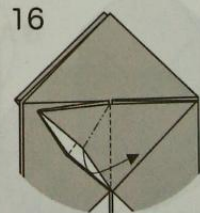
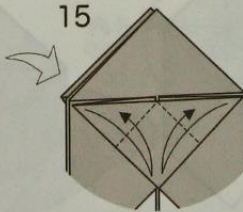
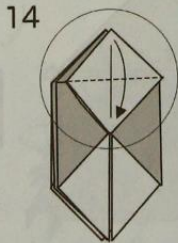
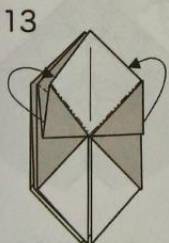

中に折り込む

1枚目だけ開く

17

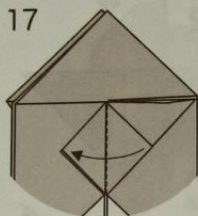

18

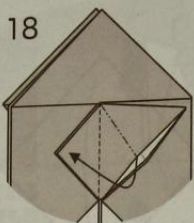

19

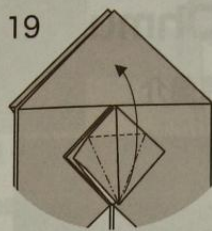

20

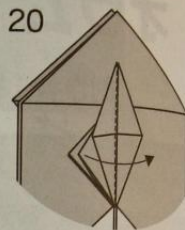

21

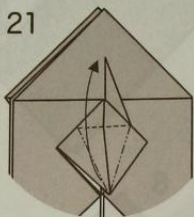

22

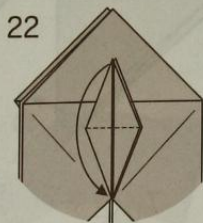

23

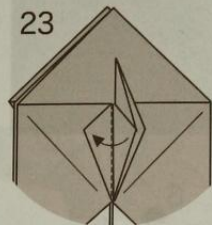

24



25

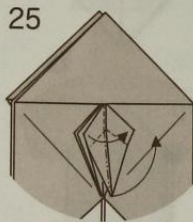

26

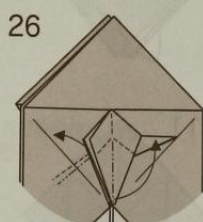

27

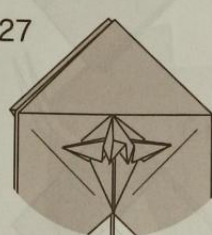

28



裏も同じ

29



30

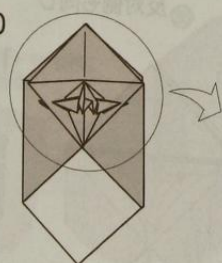

31



32



12~26の繰り返し

中に折り込む

33



34

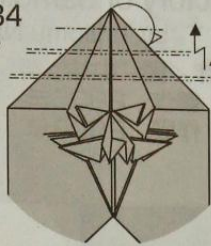

35

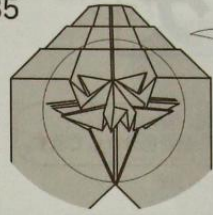

折りたたむ

36

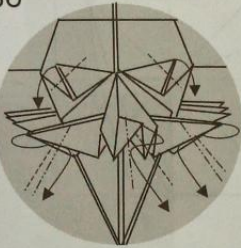

37

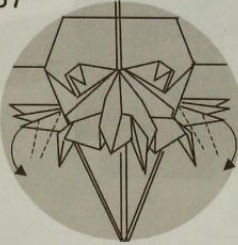

38

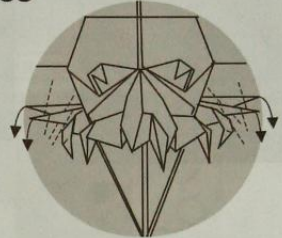

37と同様

39

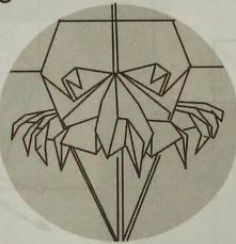

足の完成

40

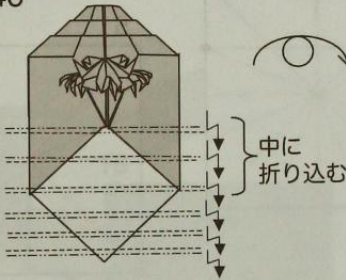

41

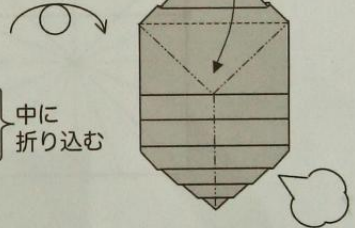

中央をふくらませる

42

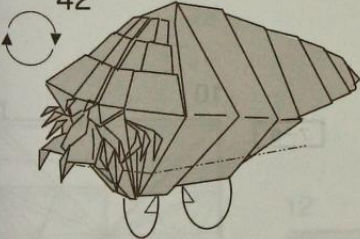

中に折り込む

43

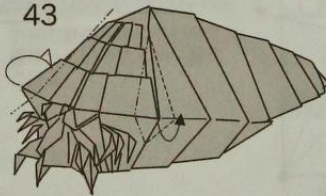

角をつぶして折りたたむ

44

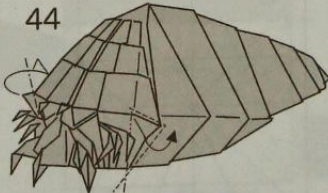

角をつぶして折りたたむ

45

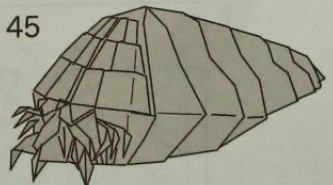

腹部の形を整えて完成

ニケ

The Winged Victory of Samothrace by Tsutomu Nakai

作/図 中井 努

創作 2006年 6月

作図 2006年 6月



表裏同色の紙が望ましい。
理解のため表裏を色分けして示す。

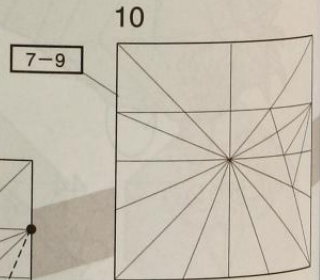
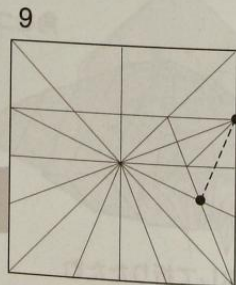
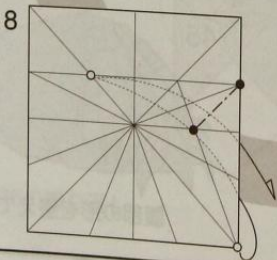
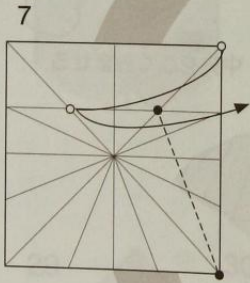
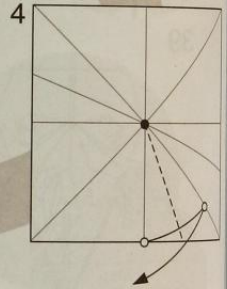
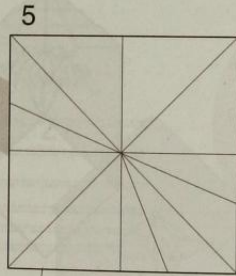
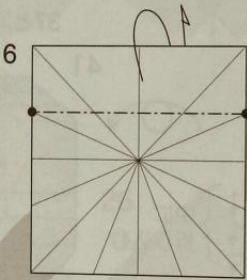
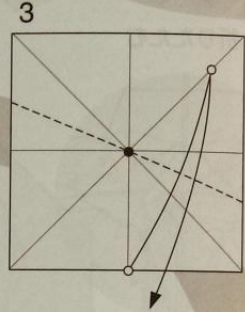
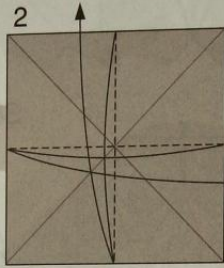
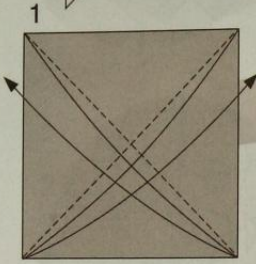

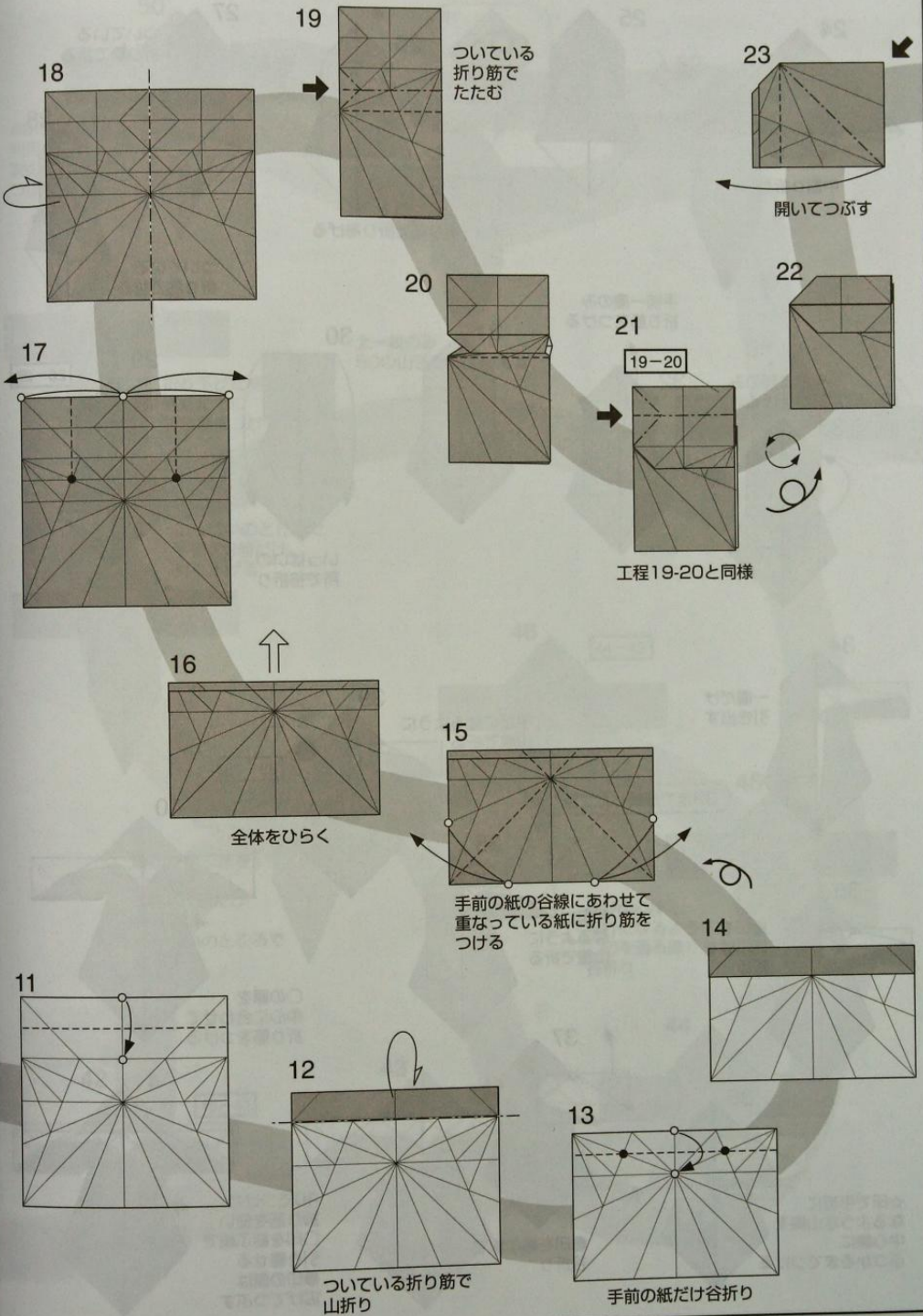

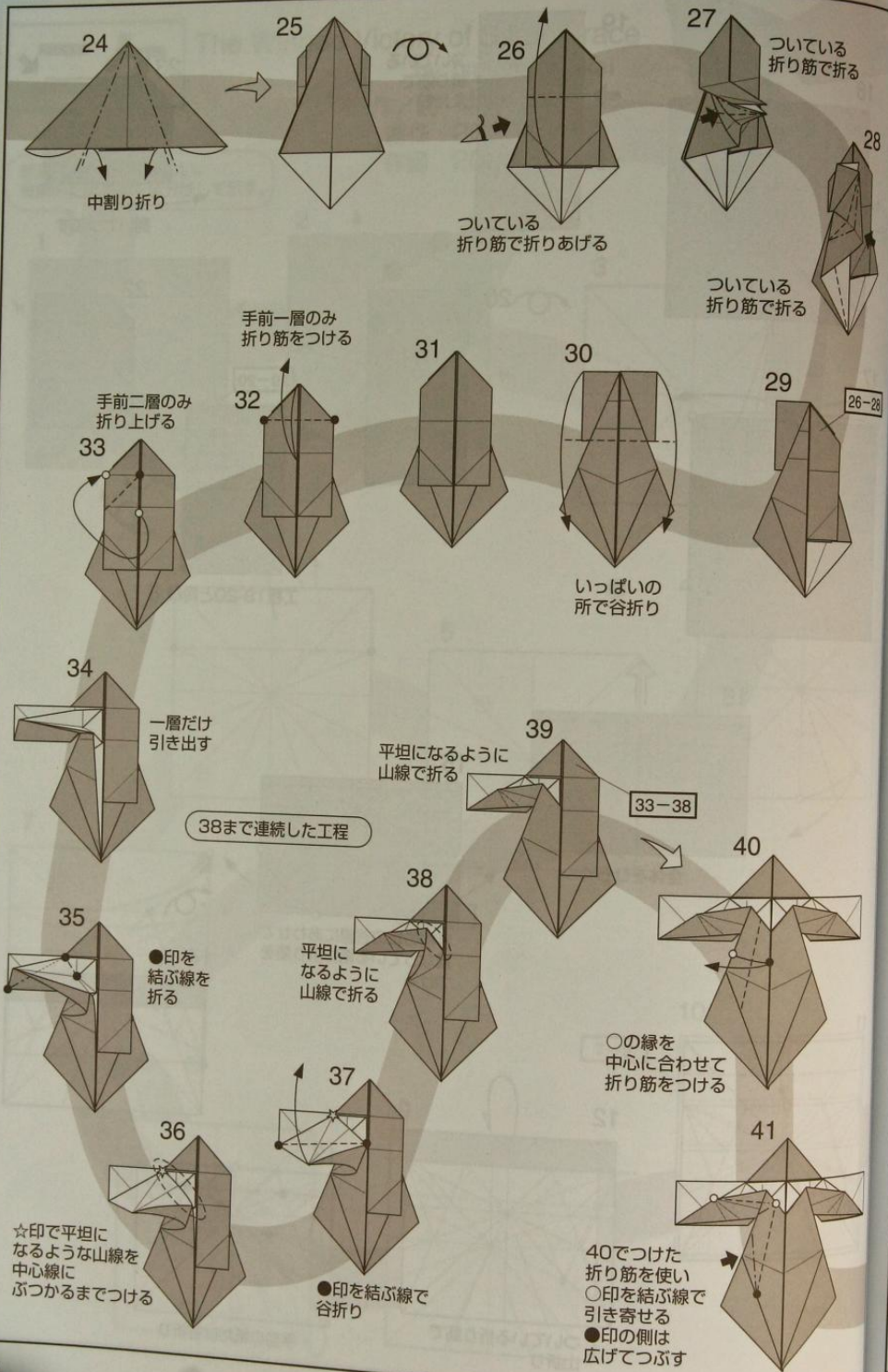

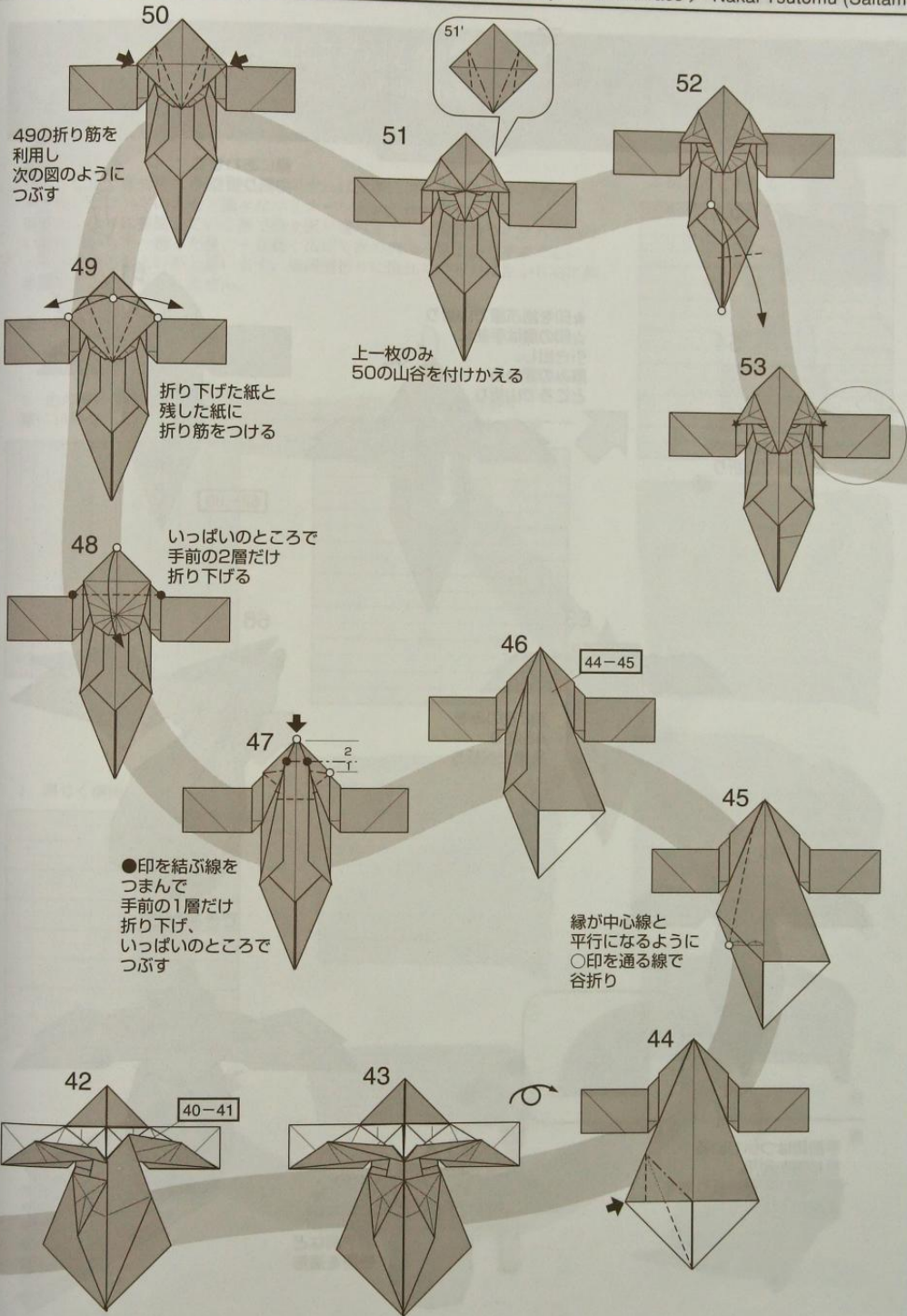

49の折り筋を利用し
次の図のように
つぶす

折り下げた紙と
残した紙に
折り筋をつける

いっばいのところで
手前の2層だけ
折り下げる

●印を結ぶ線をつまんで
手前の1層だけ
折り下げ、
いっばいのところで
つぶす

上一枚のみ
50の山谷を付けかえる

線が中心線と
平行になるように
○印を通る線で
谷折り

40-41

44-45

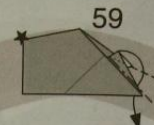
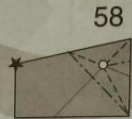
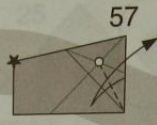
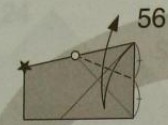
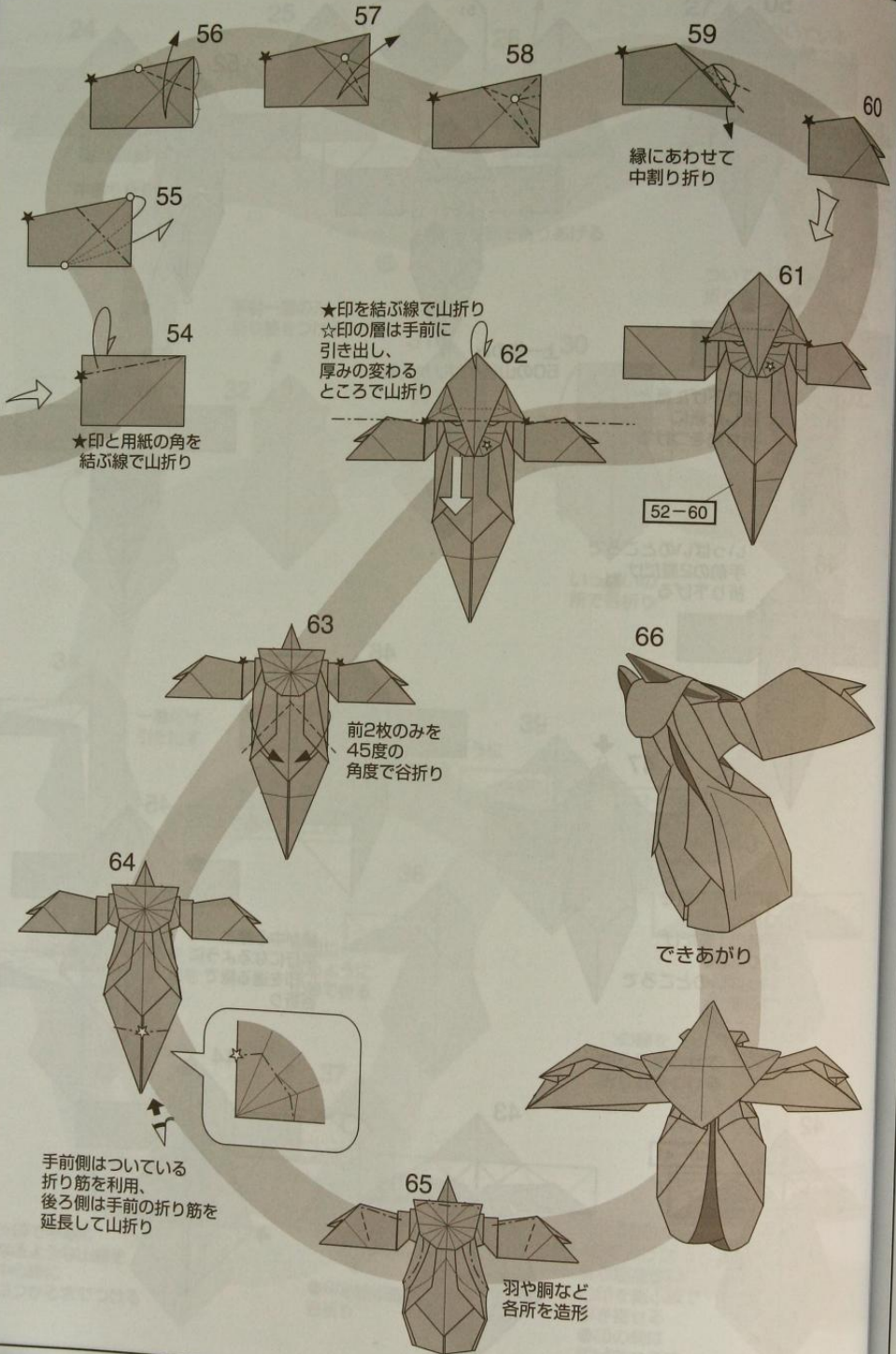

縁にあわせて
中割り折り

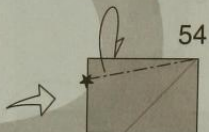
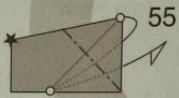

★印と用紙の角を
結ぶ線で山折り

★印を結ぶ線で山折り
☆印の層は手前に
引き出し、
厚みの変わる
ところで山折り

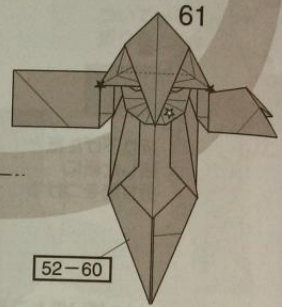
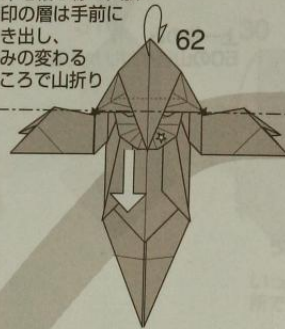

52-60



前2枚のみを
45度の
角度で谷折り

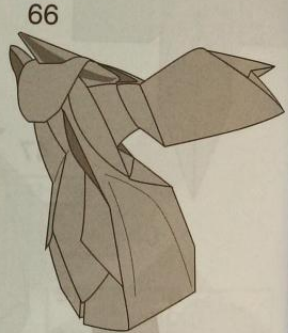

できあがり

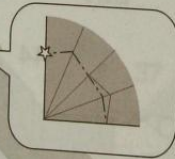
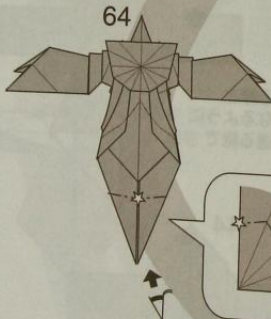

手前側はついている
折り筋を利用、
後ろ側は手前の折り筋を
延長して山折り



羽や胴など
各所を造形

かめはめ波を撃つフードの人

man in hood shooting kamehameha wave

館知宏 Tomohiro Tachi

Design : 2005/09

Diagram : 2006/06

16等分蛇腹で非対称な作品です。応用すれば片手に何かを持ったフードの人、手を繋いだフードの人など様々なバリエーションが作れます。展開図が徐々に発展していく形で折り図が進みます。展開図折りに慣れていない方は上から下へ折った後、一旦軽く広げて次の列の一番上から下までというペースで折るとよいかと思います。展開図折りに慣れている方は左から右に斜め読みできるかもしれません。

山：実線 谷：点線

0. 色の薄い側を表にして
縦に16等分

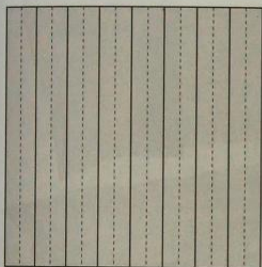

1. 同じく横向きに16等分

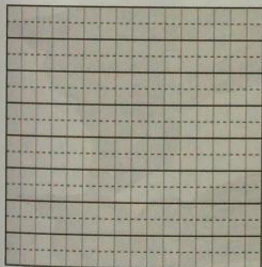

2. 中割折りの連続な折り
折り筋は紙を重ねてつけると楽

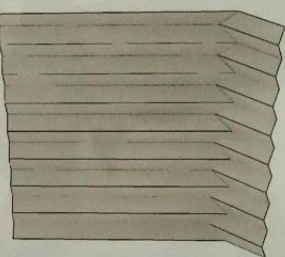
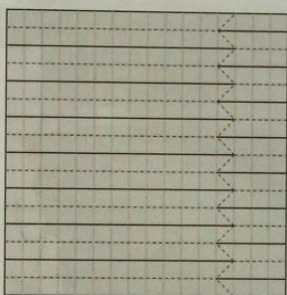

3. 図のごとく折る



表
裏

4. 頭と腕のあたりを折る

5. 二足を分離する

6. かめはめ波部分を作る

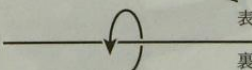
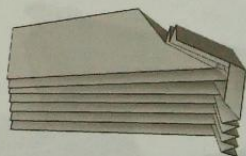
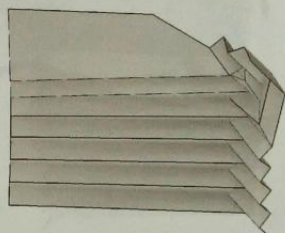
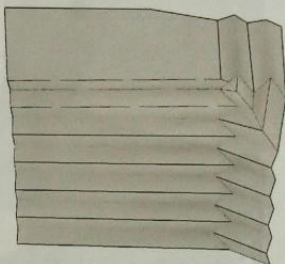
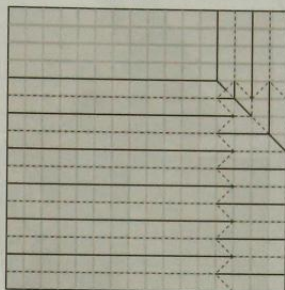
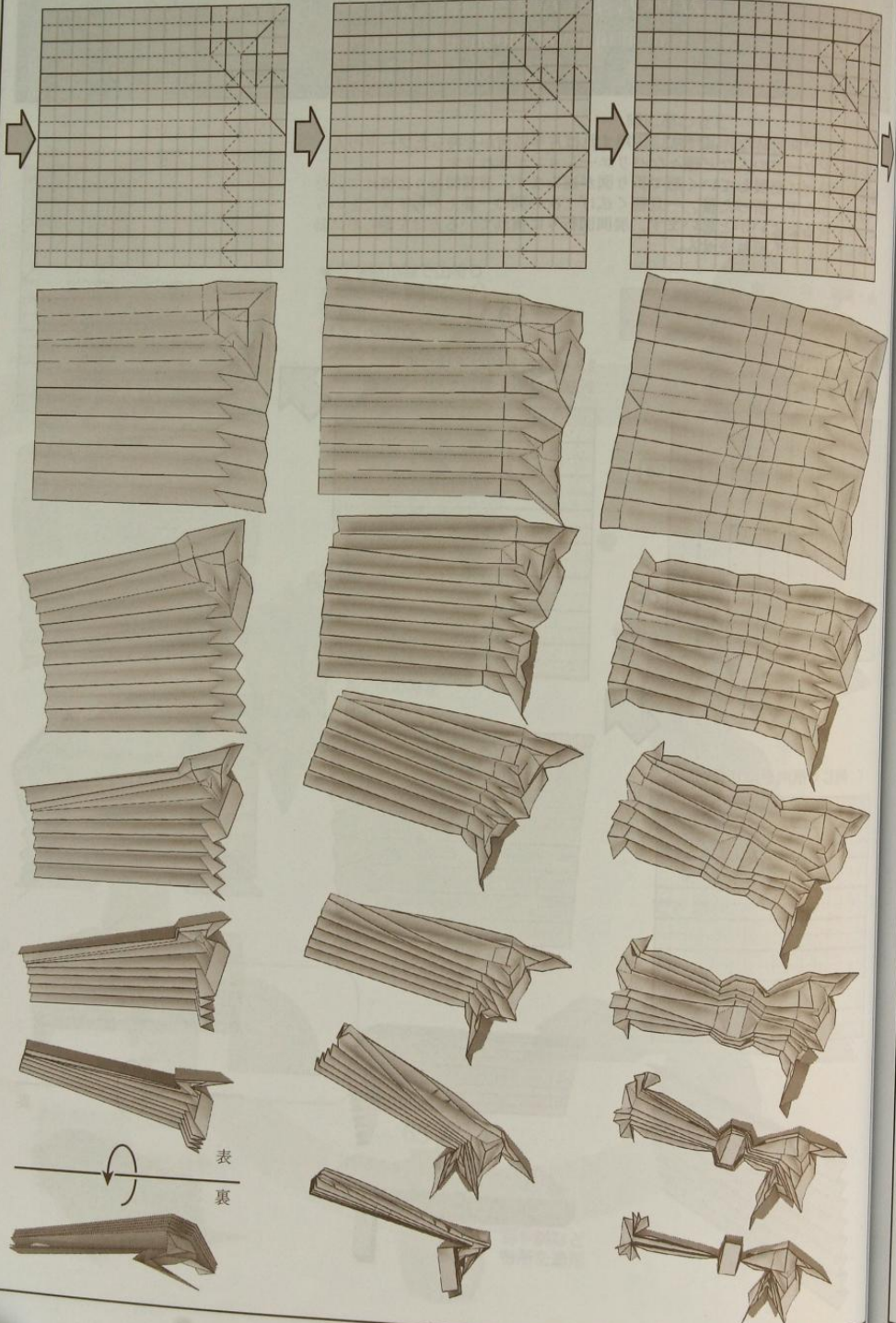

7. 手足のインサイドアウト及び角の沈め折り

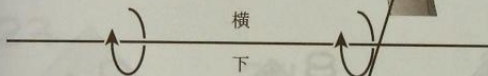
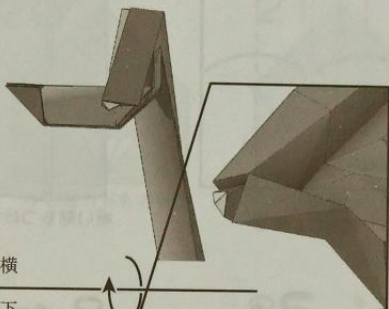
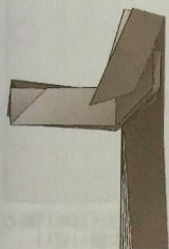
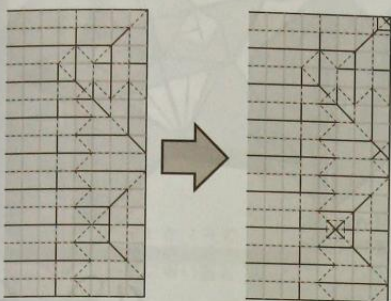

8. 仕上げ

- a. 手足をつまんで半分の細さにする。
- b. 手足の関節の角度を調整する。
- c. 襷を軽く潰して顔を作る。
- d. かめはめ波が丸くなるように整える。

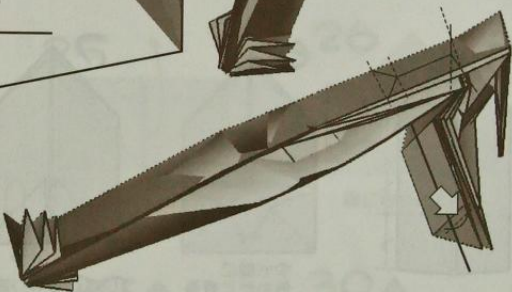

9. 完成



おほしさま

Twinkle Star

創作・作図 木下 剛

Design & diagrams By Go Kinoshita

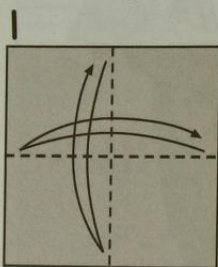
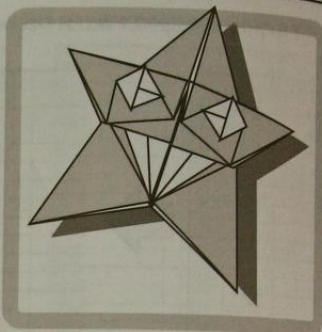

折り筋をつける

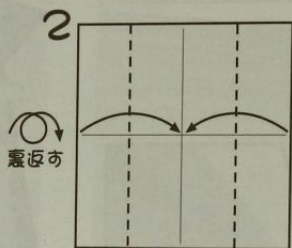

中心線に
合わせて折る

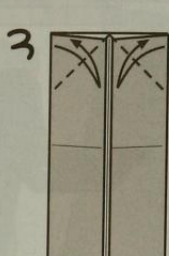

折り筋をつける

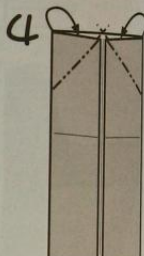

つけた折り筋で
中割り折り

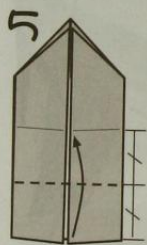

中心線に
合わせて折る



ついている折り筋で
次の図のように
端のカドだけを引き出す

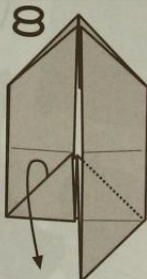

反対側も同じように

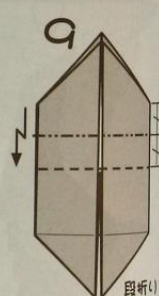

段折り

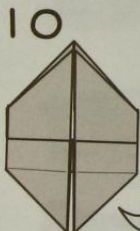

一旦元に戻す

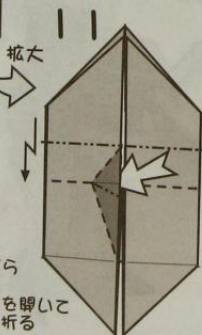

拡大

段折りしながら
一番上の紙の
濃い灰色部分を覗いて
つぶあように折る

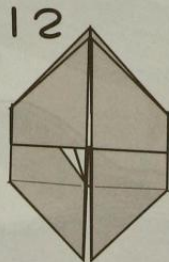

一旦元に戻す

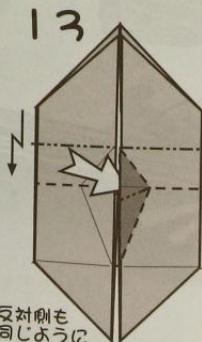

反対側も
同じように



一旦元に戻す

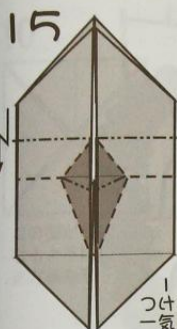

11と13で
つけた折り筋で
一気に折り畳む



2つのカドも
折り下げる

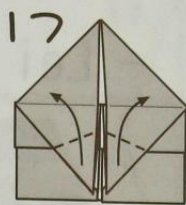

拡大

適当な幅で折り上げる

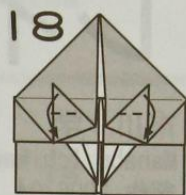

カドを合わせるように
折り下げる

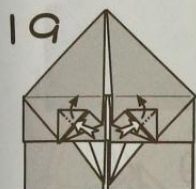

脚いてつぶす

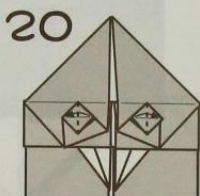

小さなカドも折る

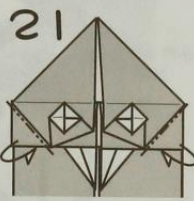

カドも巻き込みように
折る

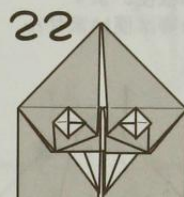

回転
裏返す

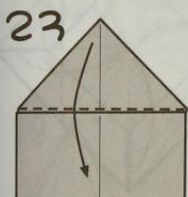

カドを折り下げる

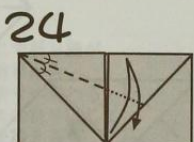

折り筋をつける

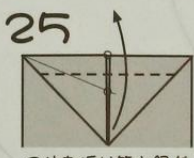

つけた折り筋と線が
合うように折り上げる

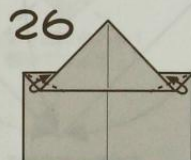

線に合わせて折る



カドの端を
引き寄せるように折る

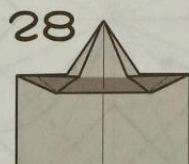

濃い灰色の部分を
あく下のヒタの中に入れる

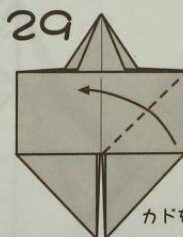

カドを折る

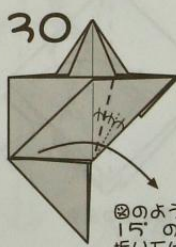

図のように
15°の角度で
折り下げる

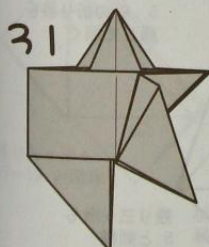

反対側も同じように



回転
裏返す

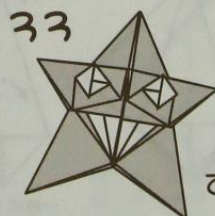

できあがり

レイ - Lei -

市川 学
Manabu Ichikawa
創作 2006/04
作図 2006/06

15cmの両面同色の紙を
70~80枚使います。
糊、糸等は使いません。

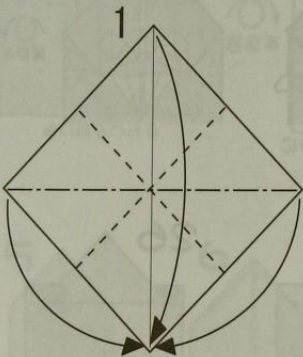
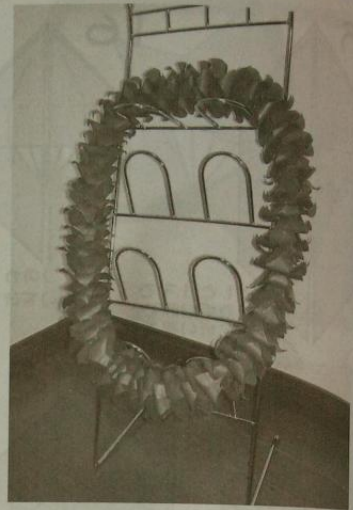
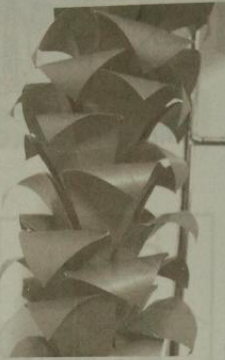

1 正方基本形を折る

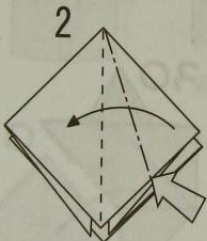

2 開いてつぶす

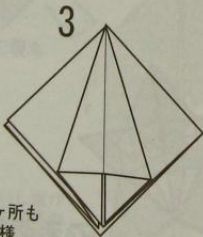

3 残り三ヶ所も
2と同様



4 一枚めくる

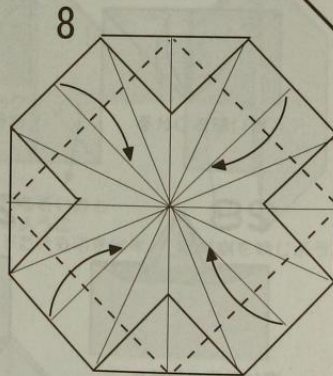

8 座布団折りの様に
中央へ折り畳む

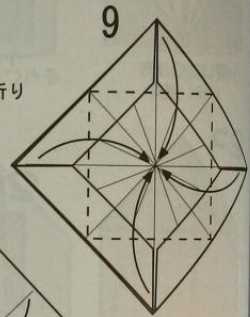

9 座布団折り



7 5, 6の折り目を
残して開く



5 折り上げる

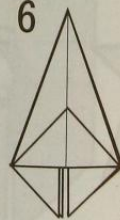

6 残り三ヶ所も
5と同様

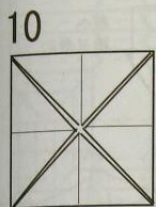

10
この面が表になるようにして
正方基本形を折る

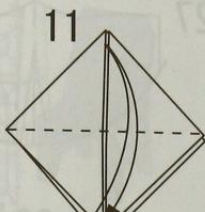

11
折り筋をつける
残り三ヶ所も同様

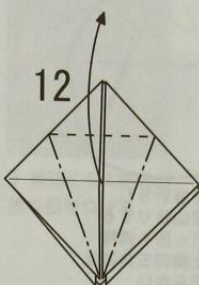

12
鶴の基本形を
折る

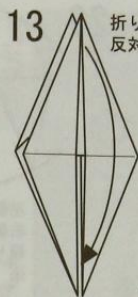

13
折り下げる
反対側も同様

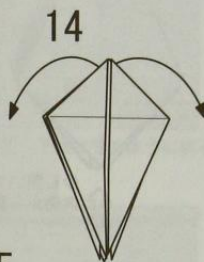

17
二枚おこす

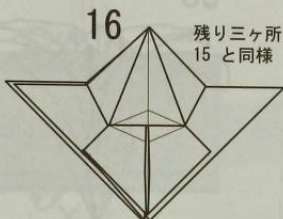

16
残り三ヶ所も
15と同様

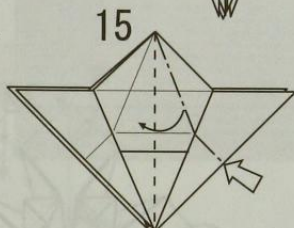

15
折り筋に合わせて
開いてつぶす



18
両側の紙を
引き出して開く



19
※ ここで折り線が
山折りから
谷折りへ変わる
全て山折りにして
形を整える

折り畳む

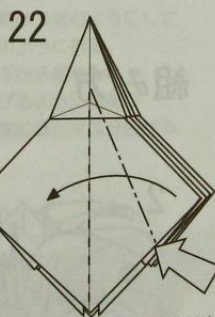

22
開いてつぶす

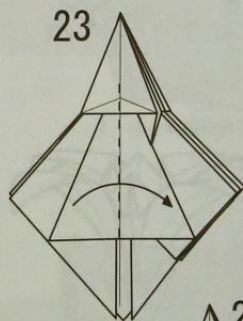

23
残り七ヶ所も
22, 23と同様

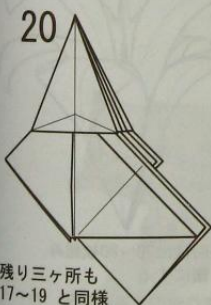

20
残り三ヶ所も
17~19と同様

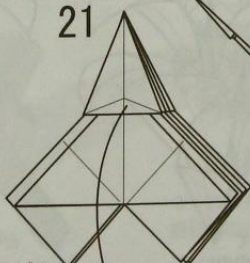

21
折り下げる
残り三ヶ所も同様

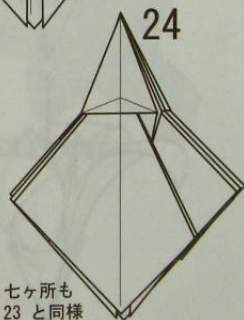

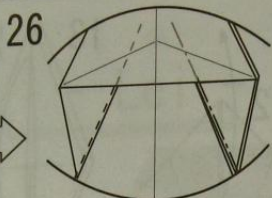
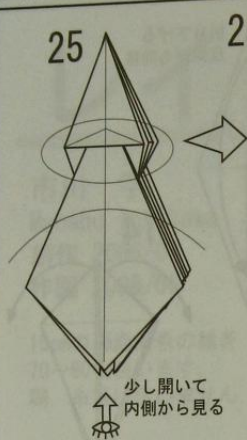

左側を谷折りし、
右側を山折りする
残り三ヶ所も同様
※ 上部の三角形は
折らない

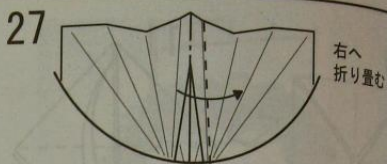

右へ
折り畳む



下へ折り畳む



両側を中央へ段折り

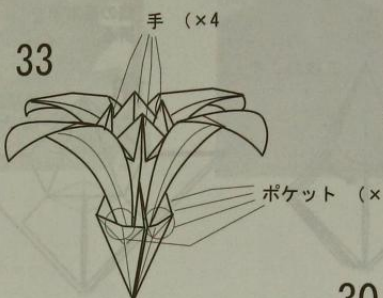

ユニットの完

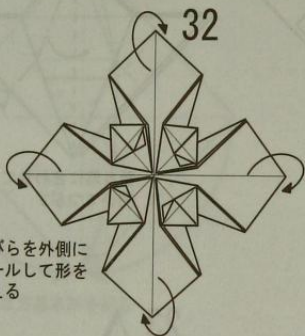

花びらを外側に
カールして形を
整える



あやめの
基本形の様に
折り畳む

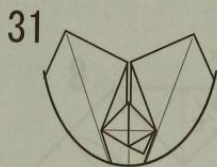

残り三ヶ所も
27~30 と同様

組み方

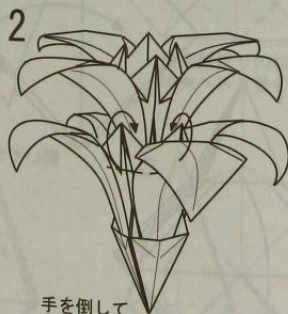
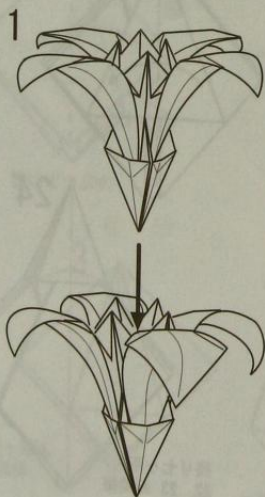

手を倒して
ポケットの中に
差し込む
反対側も同様



1, 2 と
同様1に70~80枚組み
輪にする

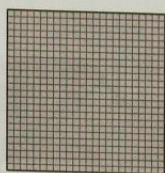
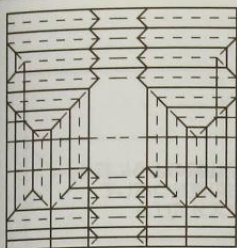

1 縦横に24等分の
折り目をつける

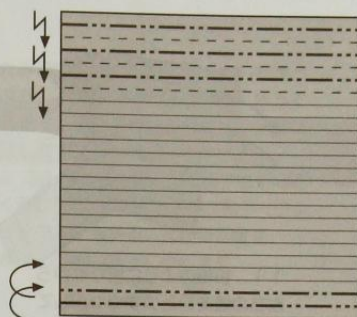

2. 上端は段折, 下端は巻くように折る.

折りたたみ椅子

Camp chair
by Yoshio TSUDA
created May 18, 2006

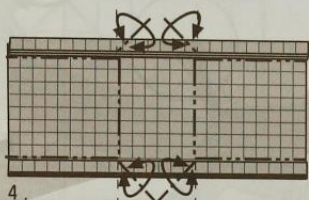

4. 左右から10個目の角(4カ所)を
つまむように折る.

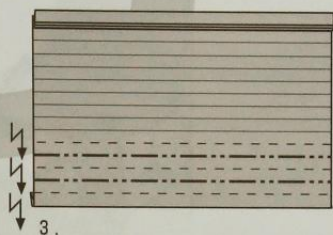

3.

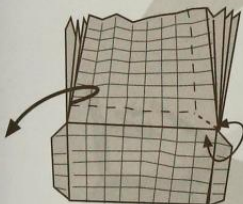

5. 折り線のように折りながら
左側の襞をひとつつぶして
ひとマス分左に広げる.

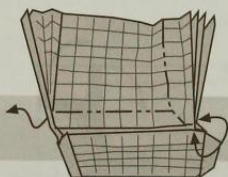

6. 右側はつまむようにして
山折線のように折る.
左側は下から指を入れ
押し上げるように襞をつ
ぶして左にひとマス分広げる.

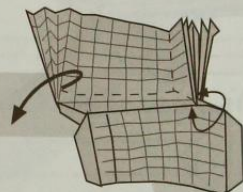

7. ⑤と同様に折る.

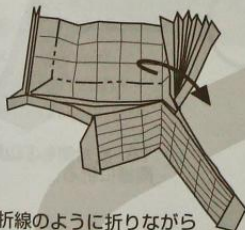

10. 折線のように折りながら
右側の襞をひとつつぶして
一マス分右に広げる.

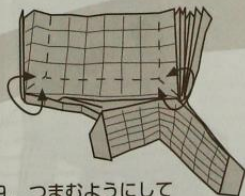

9. つまむようにして
折り線のように折る.

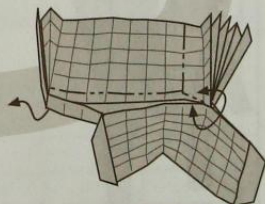

8. ⑥と同様に折る.

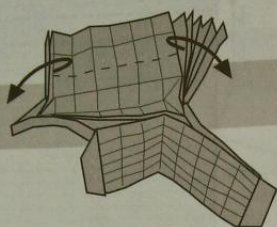

11. 折線のように折りながら
左右の襞をひとつずつつづけて
一マスずつ広げる。

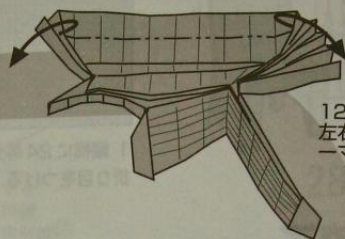

12. 山線のように折り、
左右の襞をつづけて
一マス分広げる。

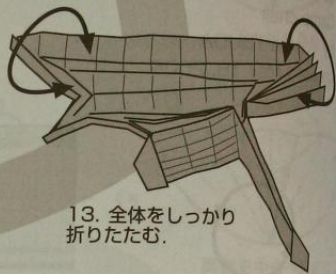

13. 全体をしっかり
折りたたむ。



14. 襞を開く。



15. 折線のように折る。

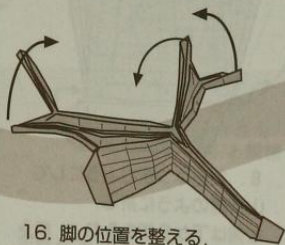

16. 脚の位置を整える。



17. 長い方の筒状の
部分に短い方を差し込む。

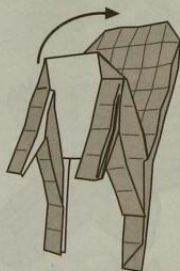

このように折りたためますが、
座るときはうまくバランスを
とらないと椅子がつぶれます
のでご注意ください (笑)

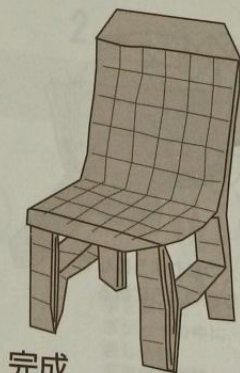

完成

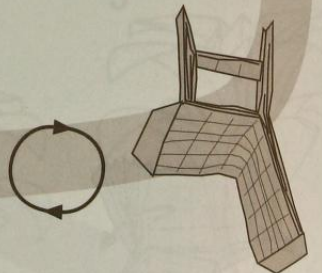

18. 反対側も⑤以降と
同様に折る。

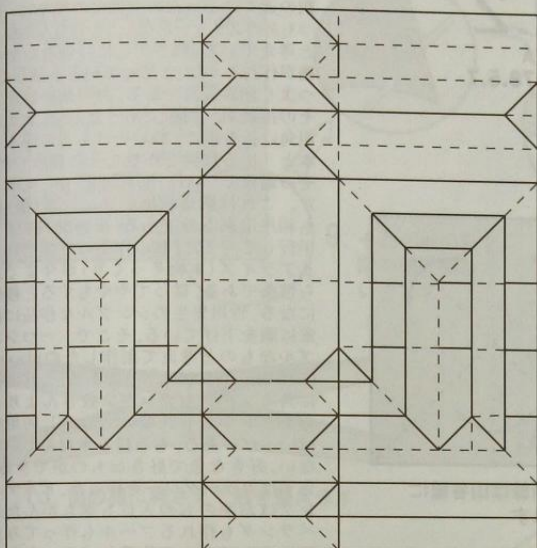

折りたたみ椅子は 24 等分を基本にして折っていますが、16 等分でもほぼ同様に折ることができます。16 等分で折る場合の展開図を左に示します。

さらに 32 等分を基本として椅子を折ると脚が長くなりうまく変形すると揺り椅子（ロッキングチェア）を折ることができます。

揺り椅子の展開図を下に示します。

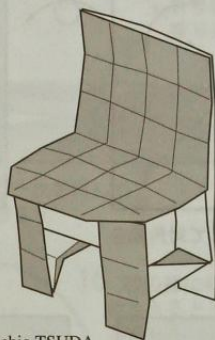

Yoshio TSUDA
created Nov. 25, 1993

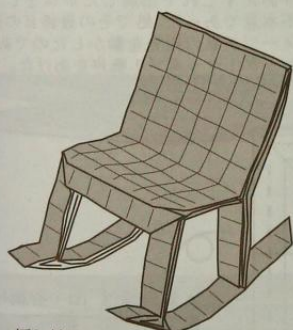

揺り椅子
(Rocking Chair)
by Yoshio TSUDA
created May 18, 2006

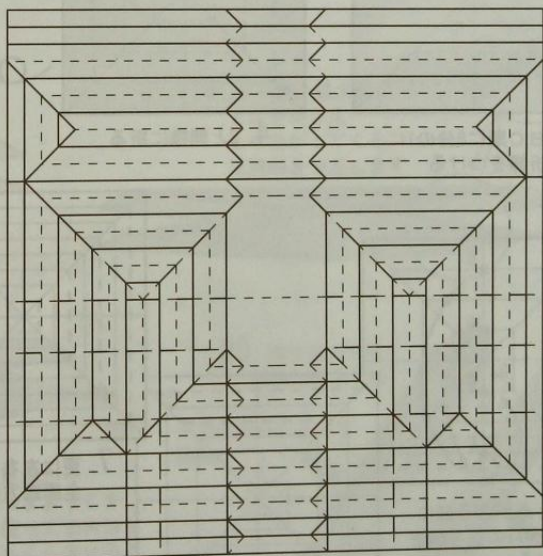

展開図をよく見て、折りたたみ椅子と同じような折り方で折ってみてください。

BUILDER-NO.2

MODEL & DESIGNED BY ICHIRO KINOSHITA
 1978.5.7
 ORIGAMI-BUILDER
 BRIDGE

半年程前(1978.5.7の)から、日本折紙協会大阪支部の例会場が大阪北の中津駅の近くにあったので例会の帰りにいつもあのブリッジがなんとなくかなんかな?と考えていて、桃谷先生に「何とかあの橋が作れんかな」と思っていると話した。つまり創作宣言である。あの細い紙骨とその接続が問題であった。とりあえず四角い折り紙で細いそれも手の四本五本と出る代物を作ることに専念した。その過程で RAIL-BUILDER が完成した。これは駅や牧場のフェンス(柵)にも利用出来るのである。平面BUILDERも平行して考えた。私の作品は立体それもリアライズ(本物そっくり)が今までから信条である。従ってややもすると複雑になる。竹川先生のシンプルな作品には常に頭を下げている。そこで一つシンプルなものと考えて創作したのが... ORIGAMI BUILDER NO1である。これは完全に角カンタンもカンタン奴さんよりもカンタンかもしれない、しかし利用度はいっぱいある。もう積み木なんていらぬ。好きな色で好きなものができる。まずはカラータワーを作った。ビルディングはお手のもの入口も窓もかんたんベランダも作れるプールも作ってみたアルミホールと二枚重ねて作ったら重ね部分がうまい具合に水中ラインになって楽しかった。チェスのボードなんて簡単、お陰でチェスボードも作るハメになった。これもすばらしいものになった。キングもクイーンも要るので、これまた王冠の新作が出来た。勿論ルック(城)も馬もビショップ(僧侶)もである。そこへ大阪支部のおりがみ展の為ブリッジが急が必要となった。これは又別の作品でとりあえずこれで出展したが私としては不本意であった。処でその最終日の夜イメージが私の指先を動かしたのである。ヤッ!ヤッ! 喚声をあげた。

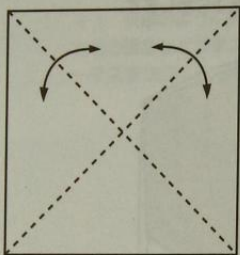

1. 裏面を上にして対角線を谷折り

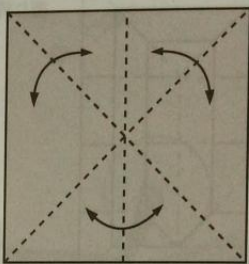

2. 対角線は山谷線にります

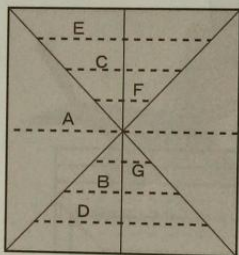

3. ABC順に8分の1に谷折線をつける

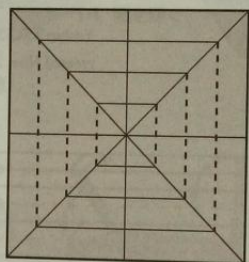

4. 3と同様に折る

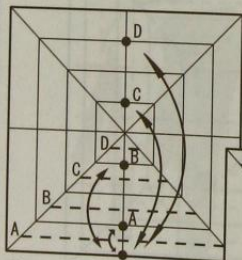

5. 点と点が合う様に16分の1の折り線をつける

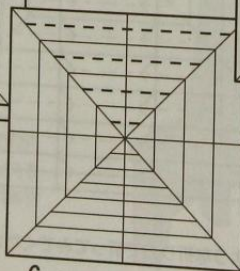

6. 5と同様に、折り筋をつける

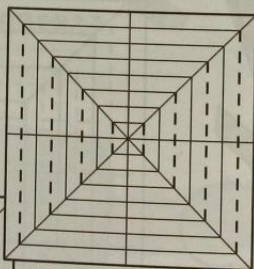

7. 更に左右も即ち全周四方向谷折り

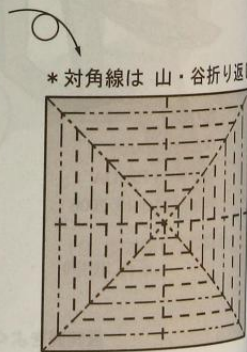

8. 折線完了図

10

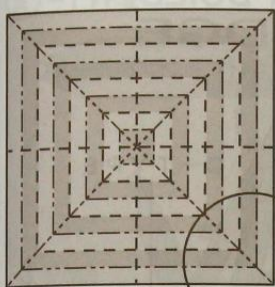

9. それぞれの角を
図の様に摘んで
いきます

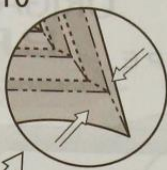

11



12. 外側から順に
折り線に従って
折り込んでいきます



13. 図の様に押さえて形を整えます

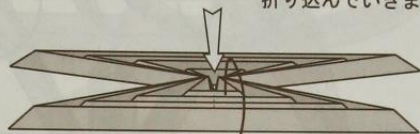

14. 台形の一枚を残して
前に開きます



15. 白矢印の所を
押さえて三角につぶす

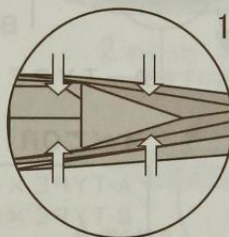

16. 図の様に4箇所を
押さえると三角に
ふくらんでくるので
それを序々に押さえて
形を整えます



17

18. 今一度、拡大図の
2点を押さえ
もりあがってくる
三角形をつぶします

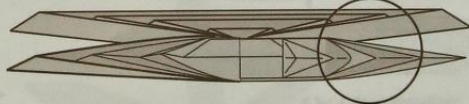

19. 最後まで同様に2点を押さえ
紙の先を矢印の方に引っ張ると
三角が若干ふくらみますので、
これも静かに上から押さえ
形を整える
これで三段のウロコの様な
三角が出来上がります

裏側から
つまようじを
使って三角形を
ふくらませると
上手く出来ます

20. 残り三カ所も
同様に仕上げる

一方は折りによって
連結している

もう一方は
分離している

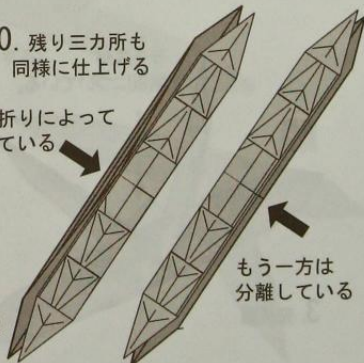

BUILDER-NO2

完成図

ORIGAMI-BUILDER BRIDGE

1978.5.7 創作 木下一郎

KINOSITA
鉄橋
 ORIGAMI BUILDER NO.2
 ICHIRO

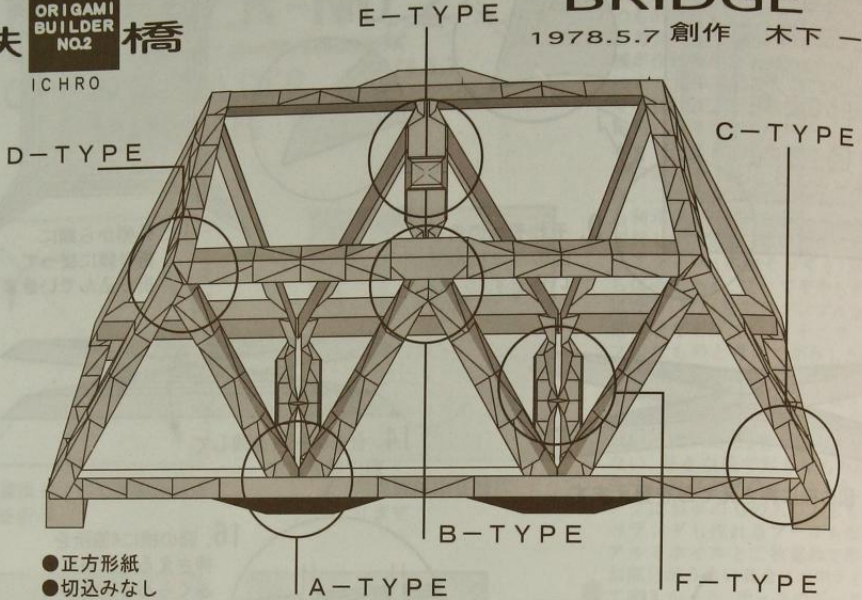

- 正方形紙
- 切込みなし
- 糊付けなし

すべてORIGAMI-BUILDER-NO2を使用

A-TYPE × 4	上向きラチス	D-TYPE × 4	上部コーナー
B-TYPE × 2	下向きラチス	E-TYPE × 1	天 接続
C-TYPE × 4	下部コーナー	F-TYPE × 2	床 接続

A-TYPE 

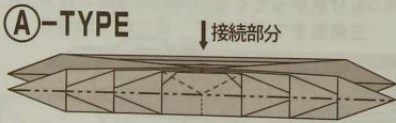

1. 次図の様に折上げる。

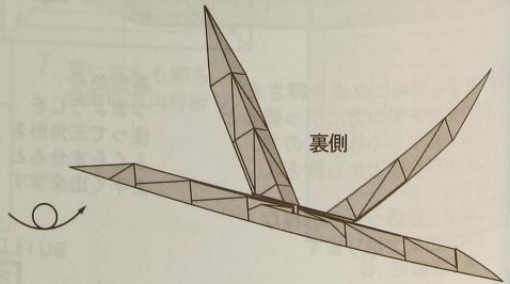
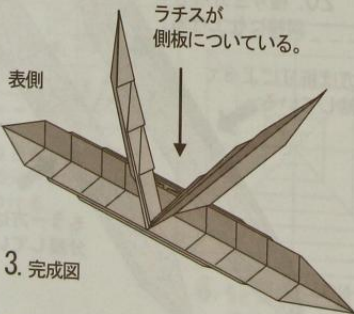
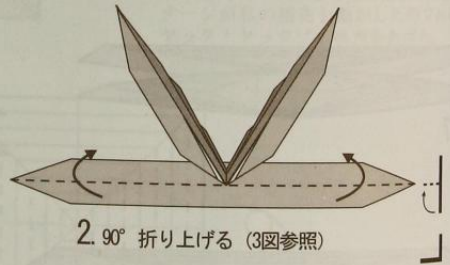

(A') -TYPE

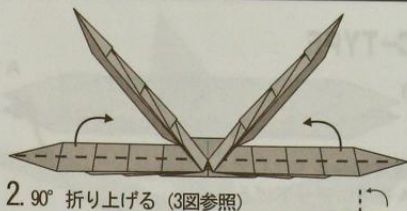
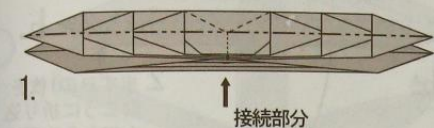

2. 90° 折り上げる (3図参照)

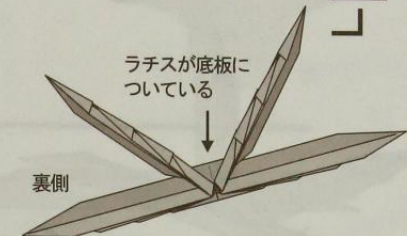
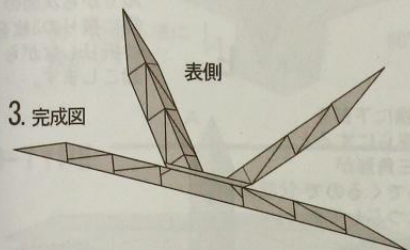

B-TYPE



1. 接続部を上にして一枚めくる。

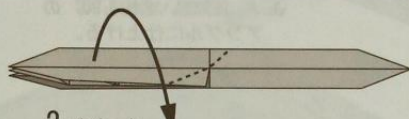

2. めくった一枚を下に折り下げる。

3. 中心を開くようにもう一枚も折り下げます。この時折り下げた2枚の後ろに三角のひだが出来る様に折る。

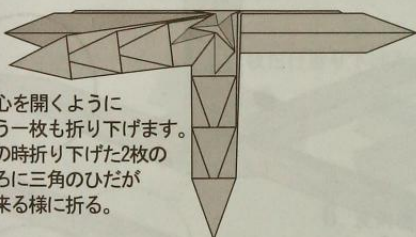

4. 中心線で折上げる。

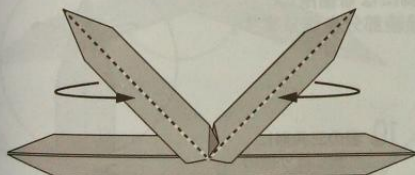
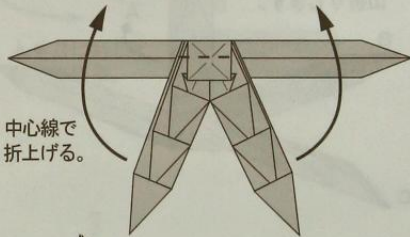

5. 折上げた2枚をそれぞれ直角に谷折りする。

6. 下の二枚を直角に谷折りする。

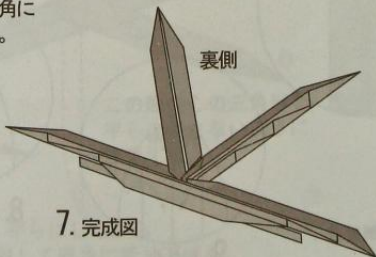
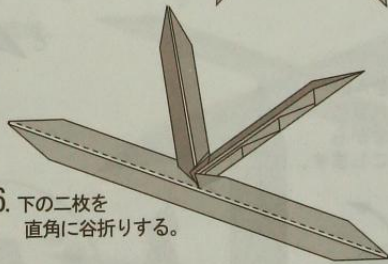

7. 完成図

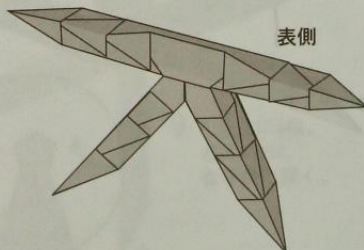

C-TYPE

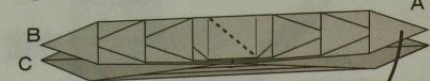

1. 接続部分を下にして
Aを下に折り下げる。

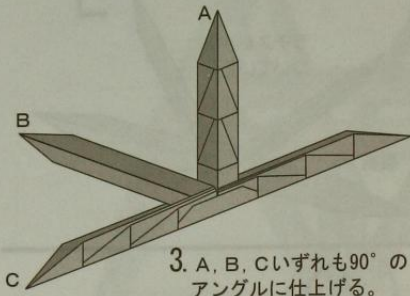

3. A, B, Cいずれも90°の
アングルに仕上げる。

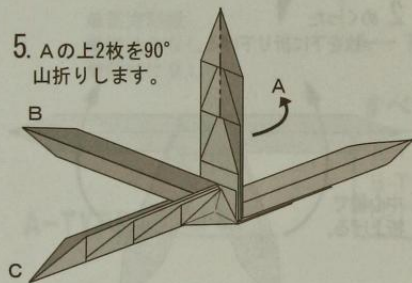

5. Aの上2枚を90°
山折りします。

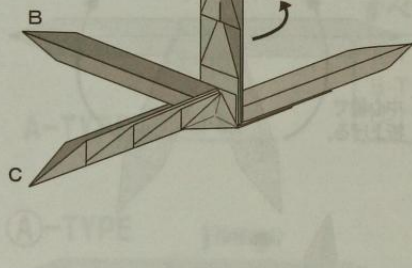

12. 接続部分をAの
裏側の割れ目に
差し込んでから
全体を起こします。

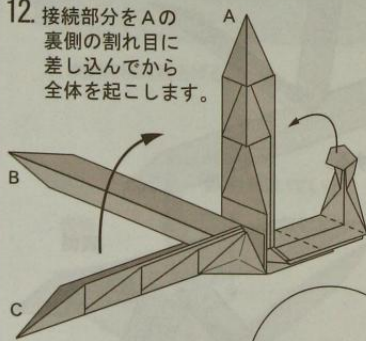

11. 接続部完成

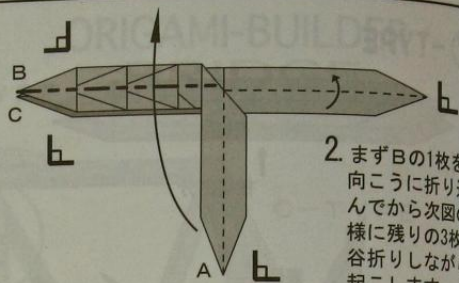

2. まずBの1枚を
向こうに折り込
んでから次図の
様に残りの3枚を
谷折りしながら
起こします。

4. 次図5の様に下部を
開きAを平らにすると
中心の三角形が
ふくらんでくるので
立体的につぶしておく。

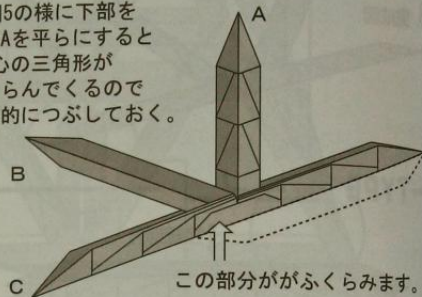

この部分ががふくらみます。

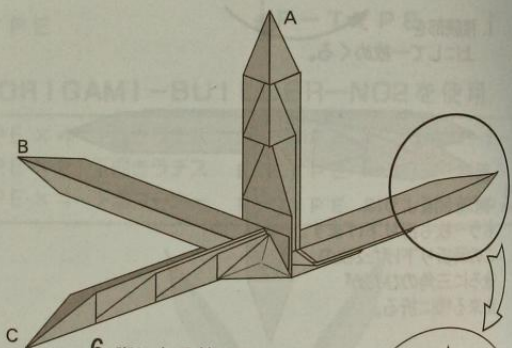

6. 脚になる箇所の
接続部分を作ります。

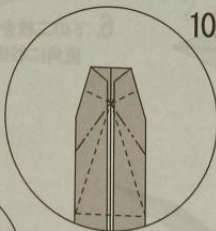

10. 表の三角形に
そって折り線の
様にたたむ。

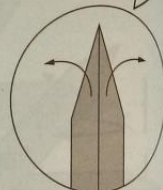

7. 開く。

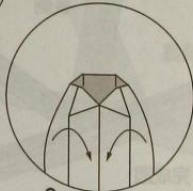

9. たたむ。



8. 頂点を内側の
三角形の頂点に
あわせて谷折り。

8. B, Aを

13.

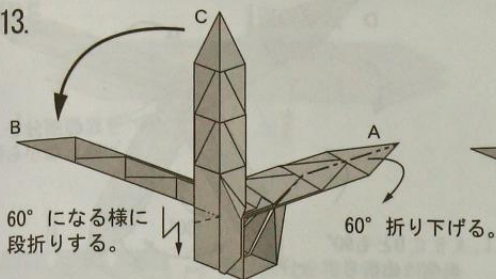

14. 完成図

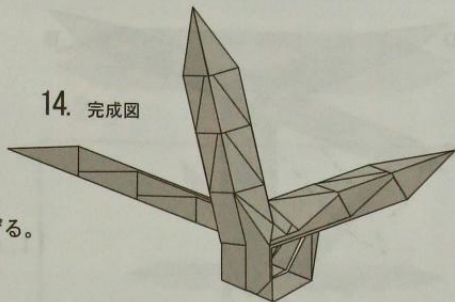

D-TYPE

↓ 接続部分

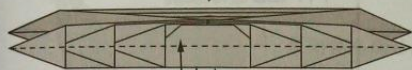

1. 下部分を
折り上げる

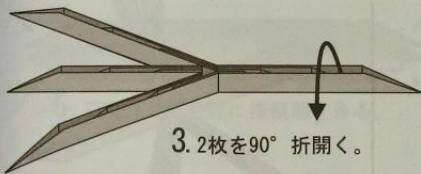

3. 2枚を90° 折開く。

1枚だけ折り下げる。



5.

6. 反対側も同様。

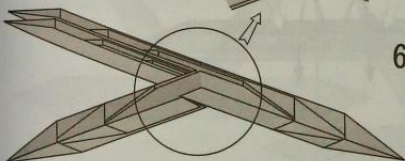

7.

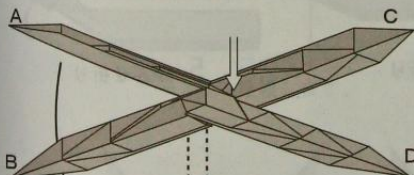
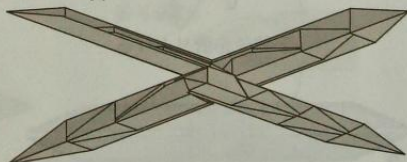

この際中心の三角形を
平らに潰さないように
注意する。

8. B, Cを、平らにしなが
ら AをDに対して直角に折り下げる。

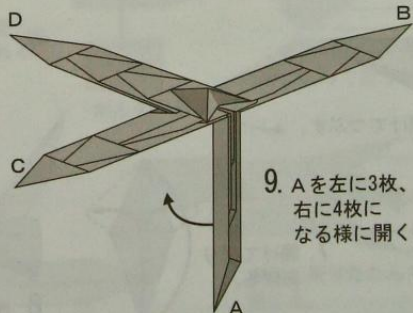

9. Aを左に3枚、
右に4枚に
なる様に開く。

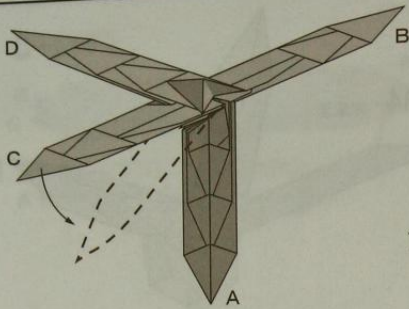

10. AとCが60°になる様に折る。

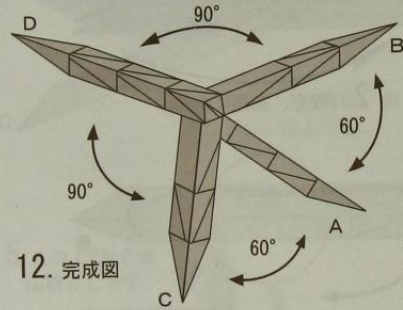

12. 完成図

拡大図の太線が
合わさる様に
折る。

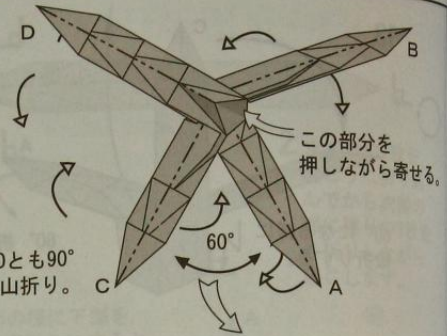

11. A, B, C, Dとも90°
奥側に山折り。

TYPE.Bとの接続

TYPE. Bの裏側に
接続部を挟み込む。

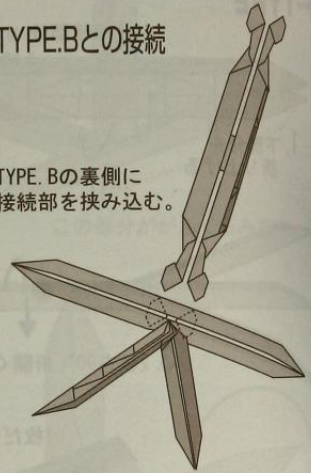

E-TYPE

↓接続部分

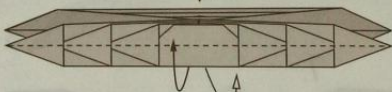

1. 下部分を折り上げる

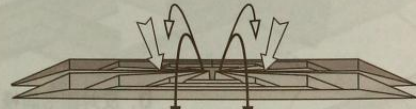

2. 両側に開く。

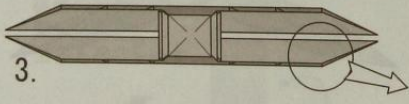

3.

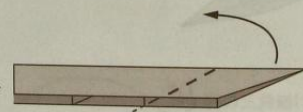

4. かぶせ折り



5. かぶせ折り



6. 開けてつぶす。



7. 開けて折り
あげる。

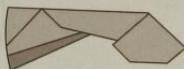

8. 四カ所とも同じ。

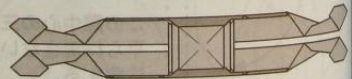

9. 完成図

F-TYPE

↓接続部分

1. 下部分を 90° に
折り上げる

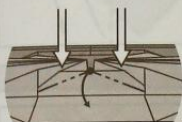

3. 矢印部分を押さえながら
中心を折下げ下図の様に
立体的につぶす。



4. 反対側も同じ。



5. TYPE. Eと同じ様に接続部を作る。

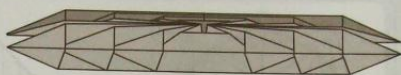

2.

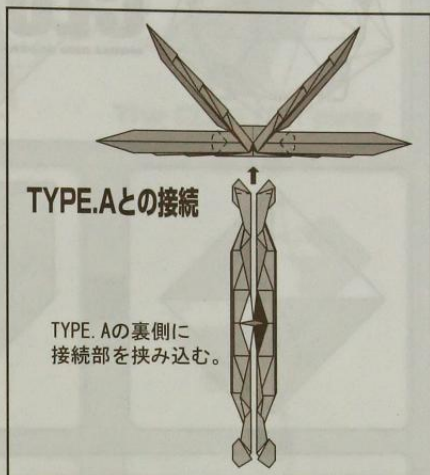

6. 完成図



オリガミ・ビルダー NO.2の接続の仕方

BUILDER - NO.2 - How to Connect -

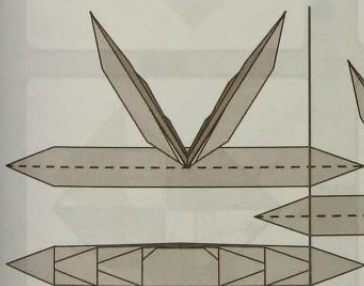

このラインで
接続します。

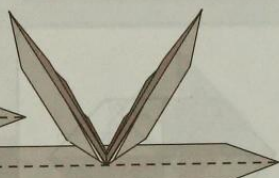

強化材を
中へ入れる。



かんのもん折り

開いて内側に
折り込む。

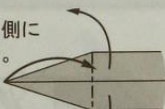

この部分に、片方を
差し込んで折りたたむ。

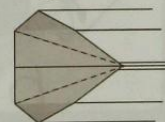

内側に折りたたんで
閉じる。

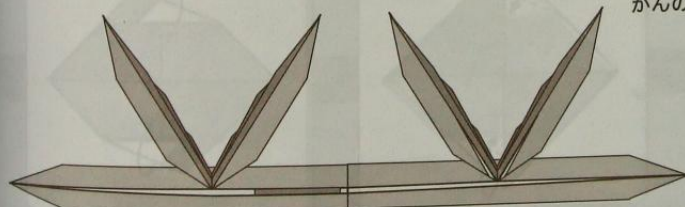
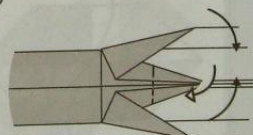

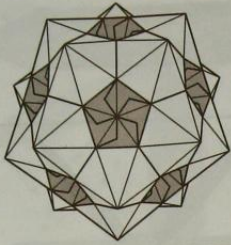

CLUSTER

MODEL AND DIAGRAMS BY TANAKA MASASHI

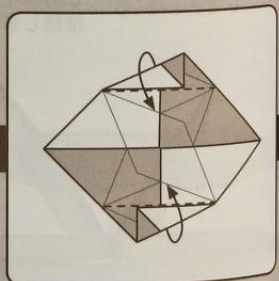
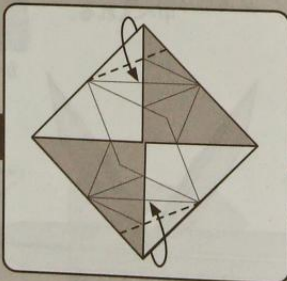
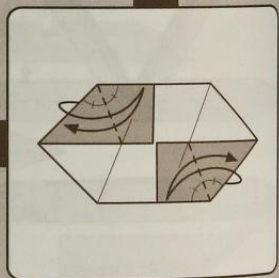
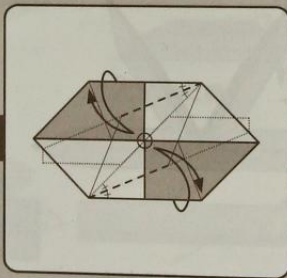
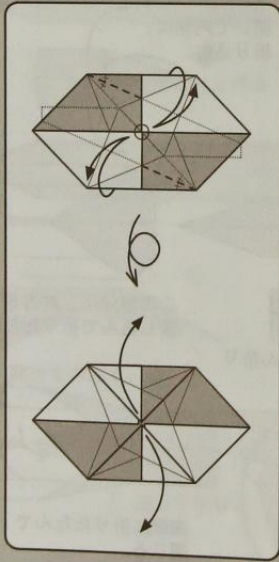
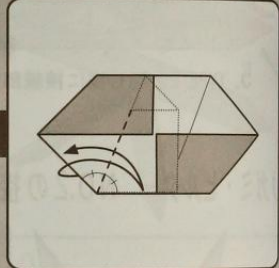
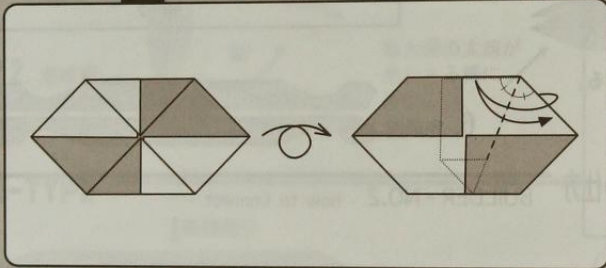
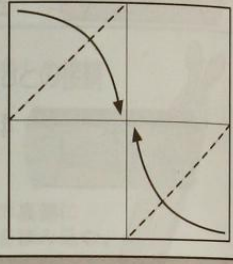
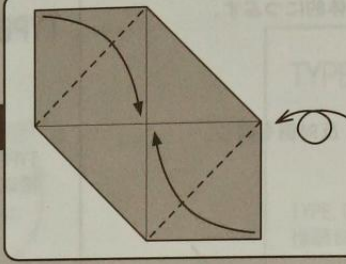
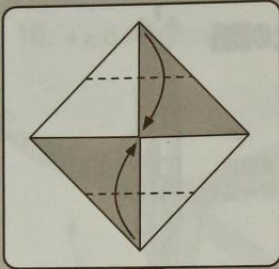
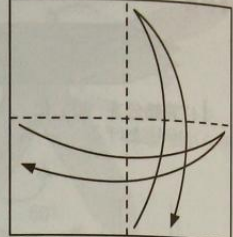

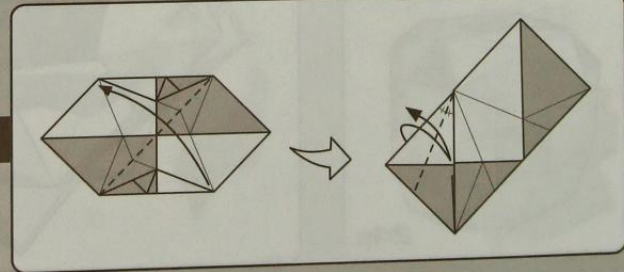
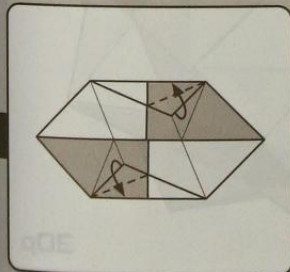
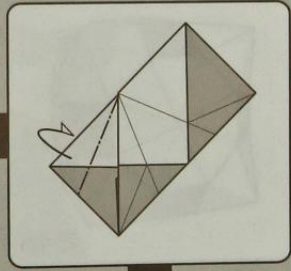
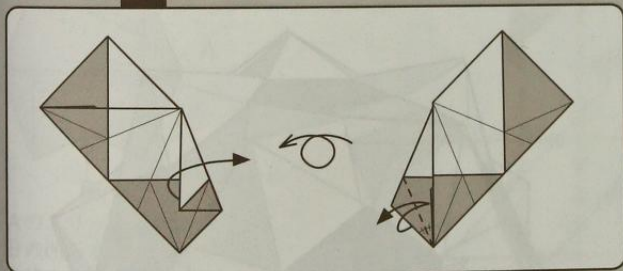
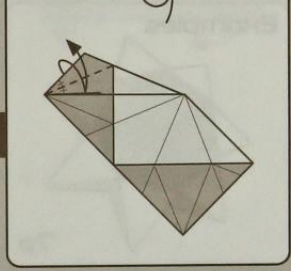
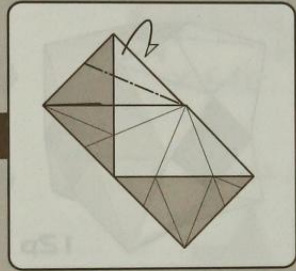
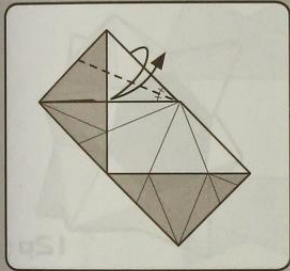
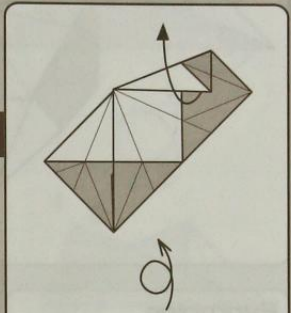
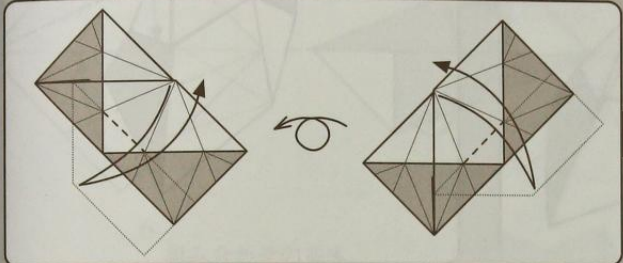
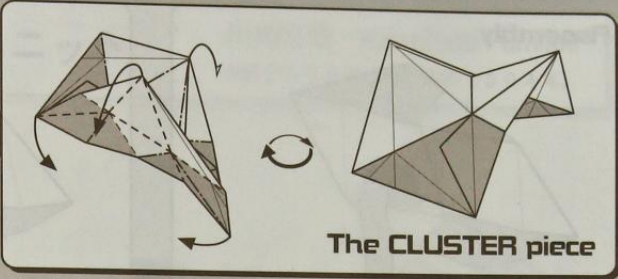
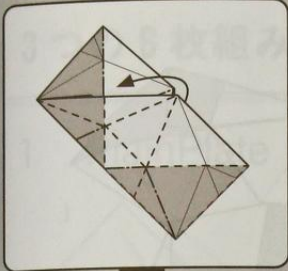

Assembly

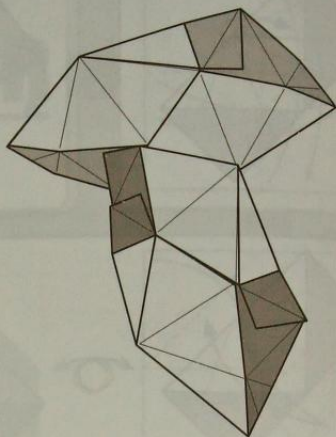
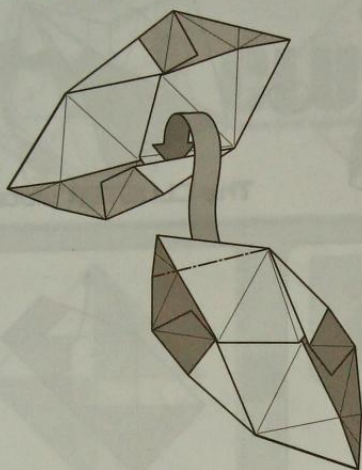

Examples

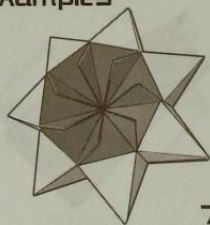

7p

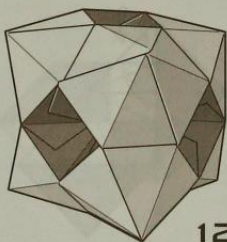

12p

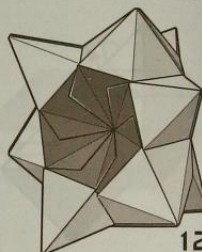

12p

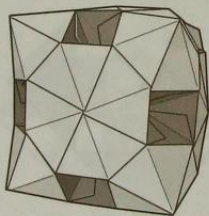

24p



24p

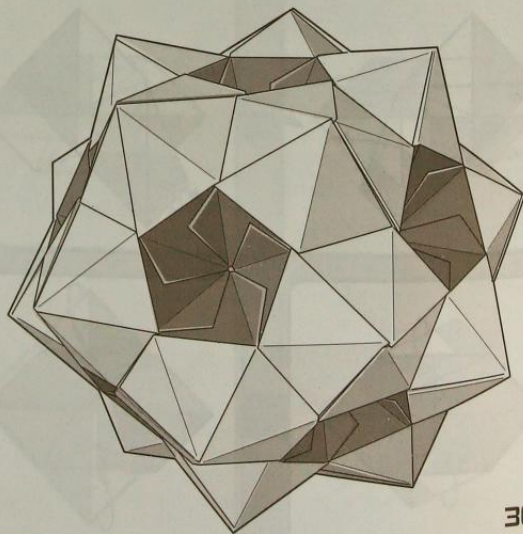

30p

3つの6枚組みユニット

川畑文昭 Kawahata Fumiaki
作図2006年6月(創作2004年)

1 PlainPlate

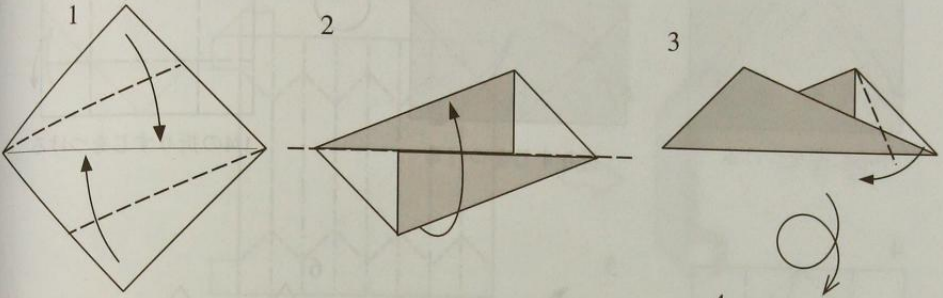

6 組み合わせの基本

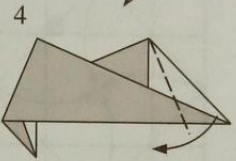
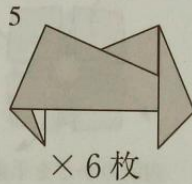
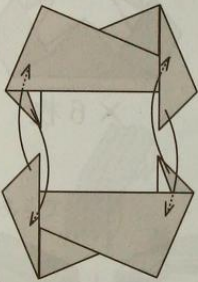

8 6枚組み合わせる

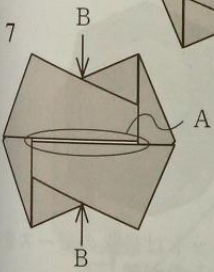

Aのスリット部に
Bの凹みをいれて
全体を組み合わせる

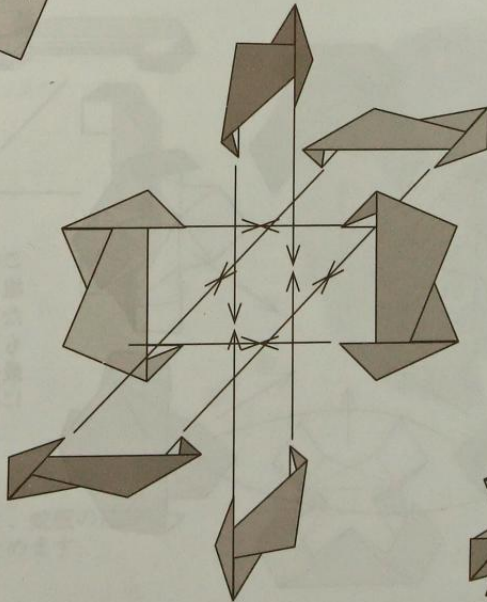

できあがり

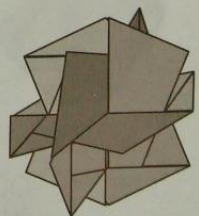

2 フラストレーションキューブ2

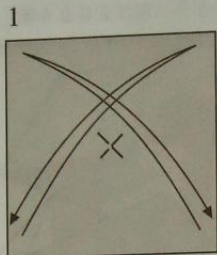

中心に印をつける

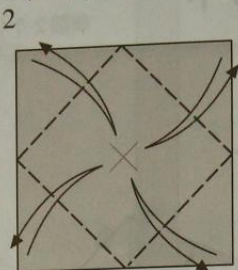

折りすじをつける

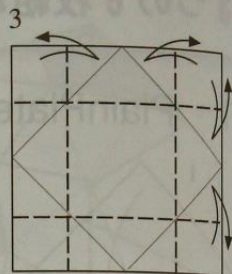
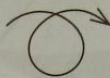

1/4の折りすじをつける

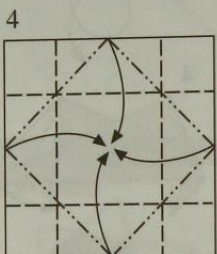

ついている
折りすじを使って
折りたたむ

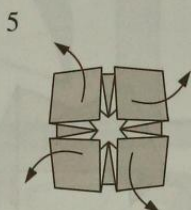

四隅のかどを手前側に
直角に立てる

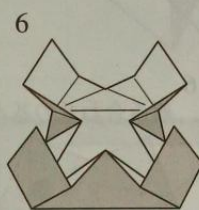

× 6枚

できあがり



7 6枚組み合わせる

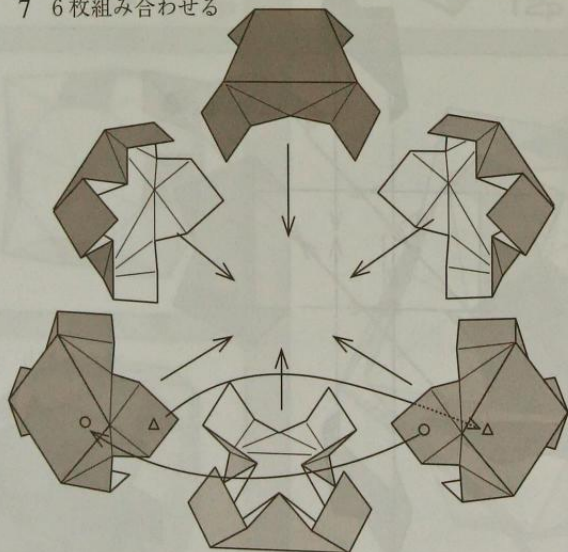

○、△の印がそれぞれあうように
互い違いに組み立てていく。

このユニットは最後のピースを
組み立てるのが難しく
たいへんストレスがたまります。
もしもどうしてもできない人は
最後にいれるピースを図1の
様に折ってください。



図1

3 ポニョポニョ

手の中で転がしても
柔らかい状態で保持
しているユニットです。

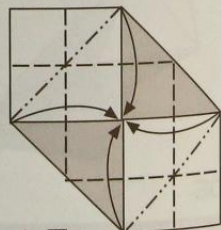
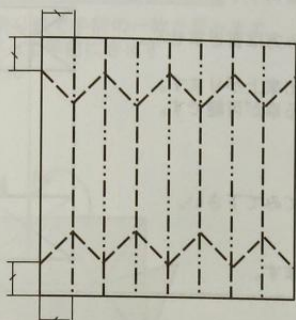

× 6 枚

1/8の蛇腹を基準に折る

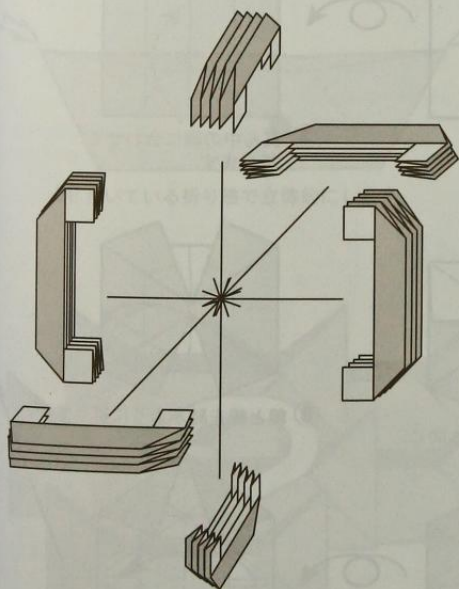

できあがり

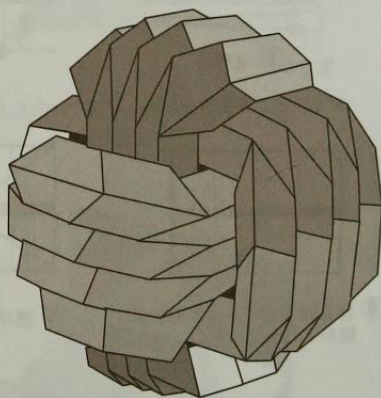

組み上げたあと、蛇腹の部分を
広げて全体を止めます

吉本キューブ YOSHIMOTO'S CUBE

作/20060618
図/20060620

Copyright Hideaki Kawashima / 川島 英明

1971年に吉本直貴さんが考案した立方体の幾何学オブジェです。

(本来は立方体から星形多面体に変化します。)

パズルの要素が強いユニットなので、あえて組み方は書きません。

1:√2の紙を6枚使います。

厚手の(100kg前後)の紙で折ると丈夫に出来上がります。

空間充填の多面体なので沢山作って組み合わせる事が可能です。

かなり簡単な折り方で出来ているので、

既に誰かが創作しているかもしれません…

パズルを楽しみたい方は右の展開図から挑戦してみてください。

細線が谷折りで太線が山折りでです。

折り図とは異なりますが、⑩の形になります。

実は展開図で畳んだ方が丈夫なユニットになります。

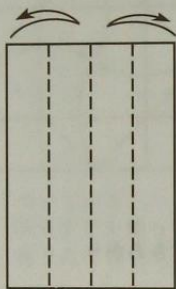
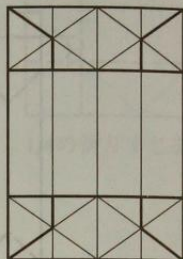

① 4等分

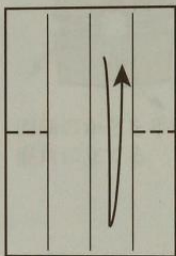

② 2等分
裏返します

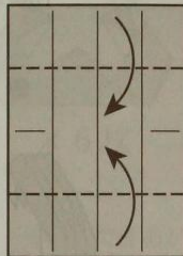
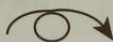

③ 真ん中の線に合わせて
折ります

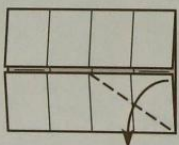

④ 線と線とを結ぶように折ります
紙がずれないように

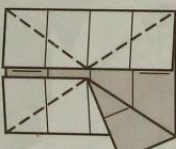

⑤ 残りの3カ所も同じ

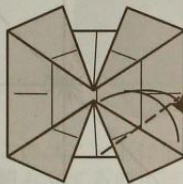

⑥ 線と線とを結ぶように折ります

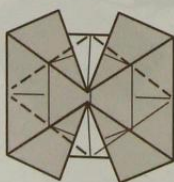

⑦ 残りの3カ所も同じ

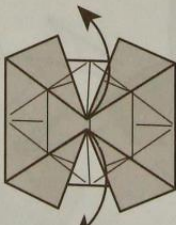

⑧ このように。
折れたら広げて裏返します

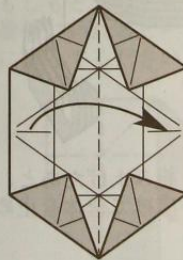
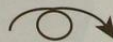

⑨ 半分に畳みます
次図90度回転&拡大

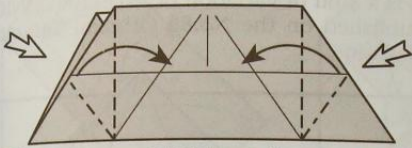

⑩ 既についている折り筋で手前の一枚を畳みます
上の紙が持ち上がって手前にきます
平面にはなりません

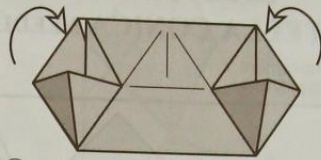

⑪ 立体図です
図のようになっていればOK
裏側も同じように畳むと平面になります

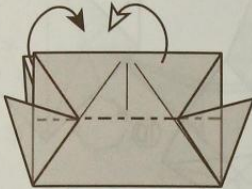

⑫ 既についている折り筋で内側に畳みます
裏側も同じように内側に紙を折り込みます
途中で紙が引っかかりますが気にせず折って下さい

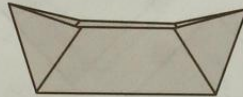

⑬ 図のようになっていればOK
次図拡大

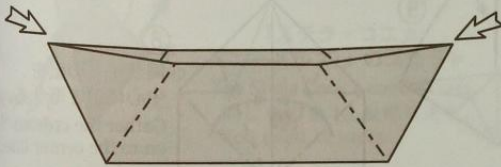

⑭ 付いている折り筋で立体的にします

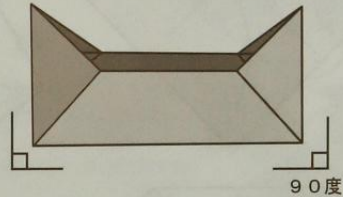

⑮ ユニット完成。同じものを6つ作ります

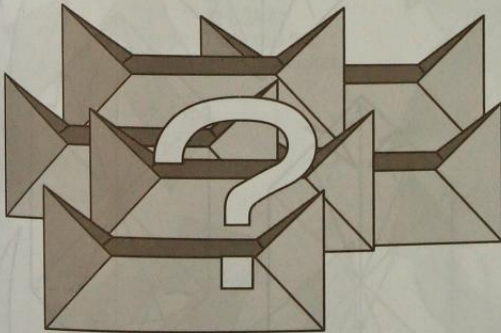

⑯ 完成図を参考に組んでみましょう

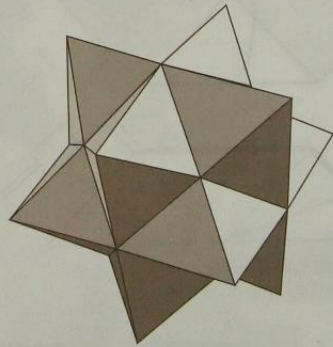

⑰ 完成図 ユニットに慣れていない人でも
5分あれば組めるとおもいます

ステラ・コニカ (ニードルズ) /STELLA CONICA NEEDLES

©2006 Miyuki Kawamura
川村みゆき

探偵団マガジン 89 号に載った「ステラ・コニカ」の親戚です。

It is a kind of variation of "STELLA CONICA" published on the No.89 Origami Tanteidan Magazine.

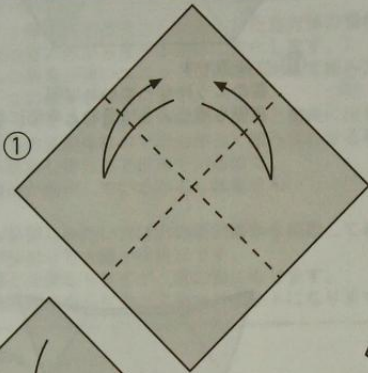

①

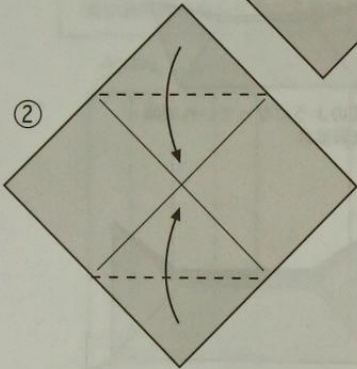

②

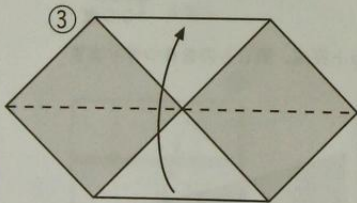

③

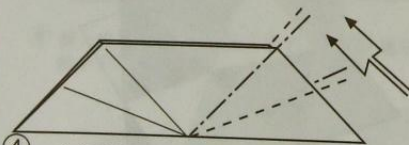

④ 左側も同じ。
Do the same on the left side.



⑤ 折ったら開く。
Unfold back to the step ③.

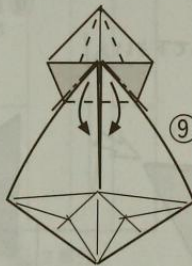

⑥

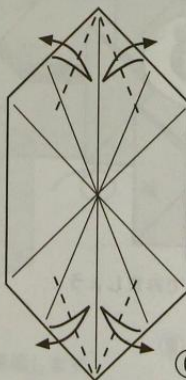

⑦

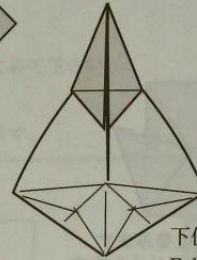

⑧

下側も同じ。折ったら開く。
Fold the same way on the lower side and unfold.

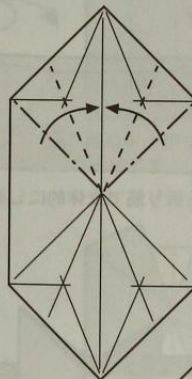

⑨

⑩ 両サイドの紙を
中心に引き寄せる。
Gather the creases
on to the center line.

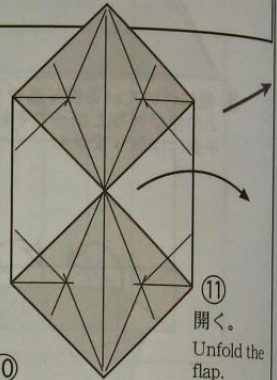

⑩

開く。
Unfold the
flap.

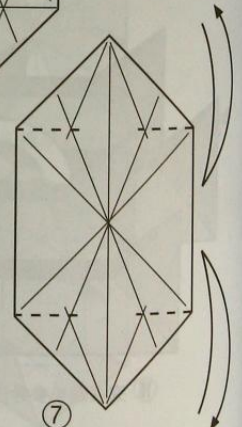

⑪

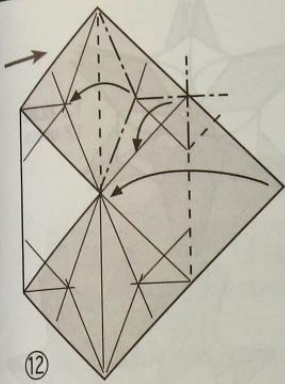

12

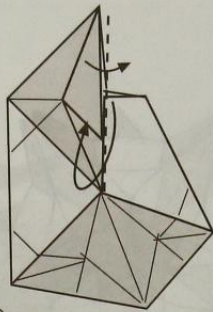

13 差し込む
Tuck the flap

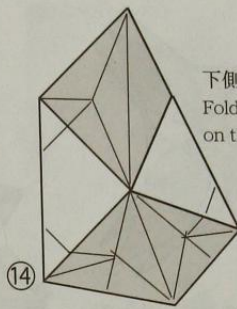

14

下側も同じ。
Fold the same way
on th lower side.

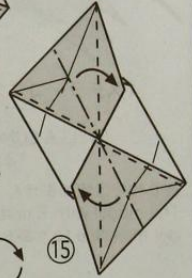

15

上から見た図
Top view.

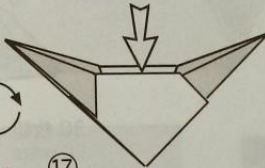

17 少し開いて立体的にする。
Open a bit. The model
becomes 3-D.

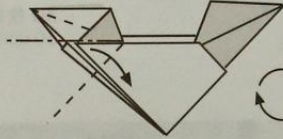

16 裏側も同じ。
Fold the same way
on th other side.

5

残りのユニットも
同様に組んでいく。
Insert the other
module the same way.

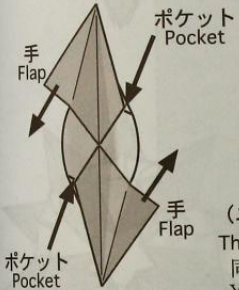
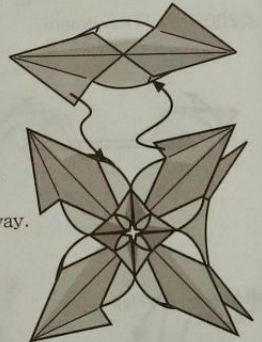

「ステラ・コニカ
(ニードルズ)」のユニット
The Stella Conica needles unit
同じものを 12 枚作ります。
You need 12 units.

組み方 / Assembly

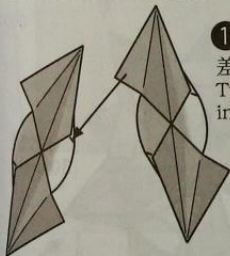

1 差し込む
Tuck the flap
into the pocket.

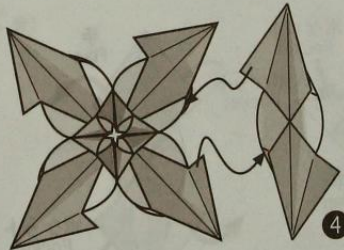

4

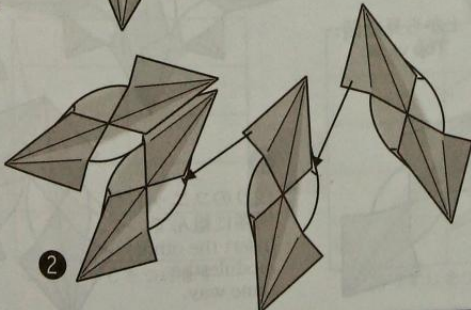

2

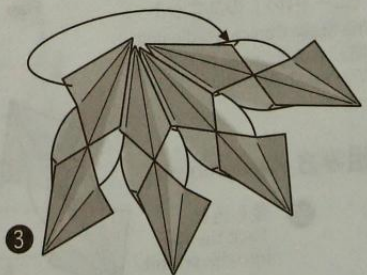

3

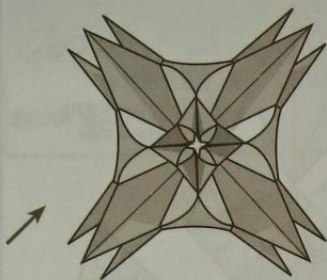

「ステラ・コニカ (ニードルズ)」
12 枚組
STELLA CONICA (NEEDLES)
12 units

※ 6 枚では組めません
The model with 6 units
is impossible to make.

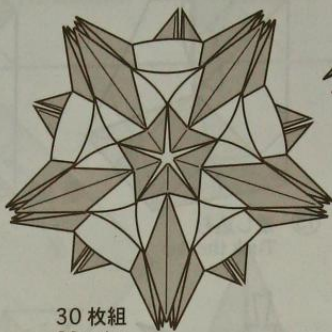

30 枚組
30 units

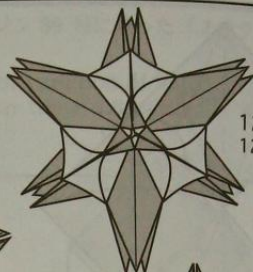

12 枚組
12 units

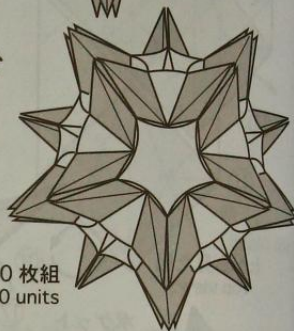

30 枚組
30 units

Design @20060615

ステラ・コニカ (ニードル) /STELLA CONICA NEEDLE

©2006 Miyuki Kawamura
川村みゆき

※ 6 枚、12 枚では組めません
The model with 6 or 12
units is impossible to make.

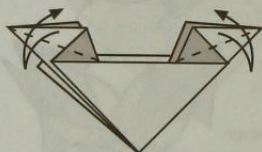

ステラ・コニカ (ニードルズ)
の⑤から。裏も同じ。
Start from the step ⑤ of the
"STELLA CONICA (Needles)".
Fold the same way on the
other side and unfold.

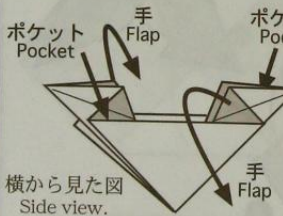

横から見た図
Side view.

「ステラ・コニカ
(ニードル)」のユニット
同じものを 30 枚作ります。
You need 30 units.

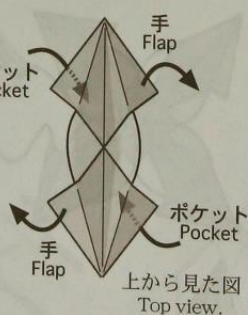

上から見た図
Top view.

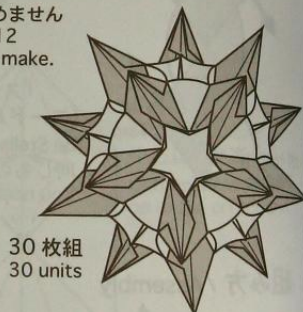

30 枚組
30 units

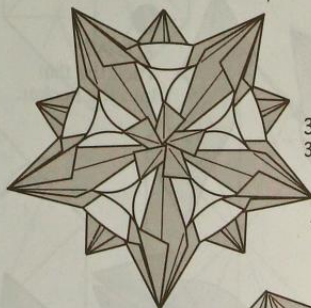

30 枚組
30 units

組み方 / Assembly

① 差し込む
Tuck the flap
into the pocket.

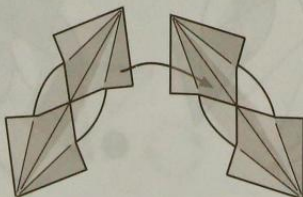

② 残りのユニットも
同様に組んでいく。
Insert the other
modulesthe
same way.

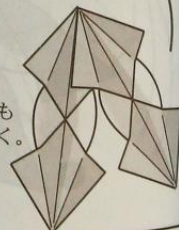

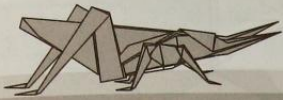

15° ショウリョウバッタ

Longheaded Locust based on 15°

作/図 西川誠司

Design & Diagrams by Seiji Nishikawa

Design: 2005. 10.

Diagrams: 2006. 07.

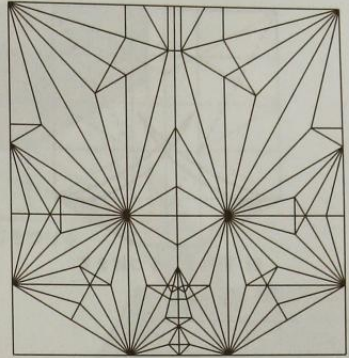

展開図：図 42 付近のもの

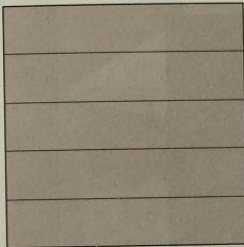

1) 水平に5等分します。

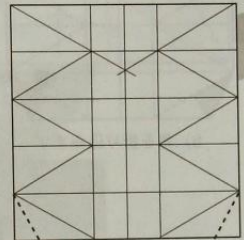

7) 角を折ります

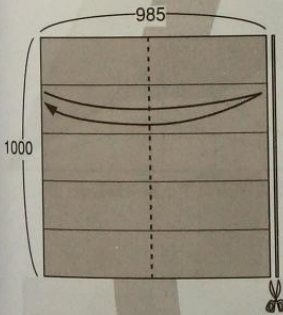

2) 端を僅かに
カットします。
(およそ 1.5% 分)

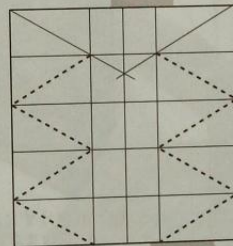

6) 折りすじをつけます

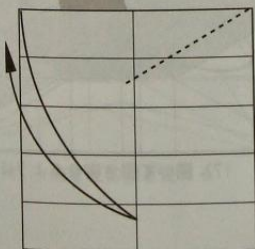

3) 折りすじをつけます

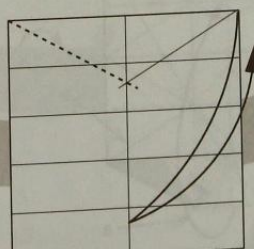

4) 折りすじをつけます

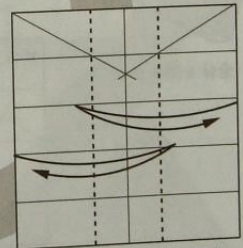

5) 折りすじをつけます

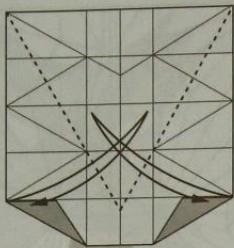

9) 折りすじをつけます

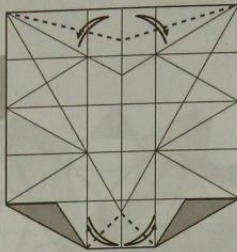

10) 折りすじをつけます

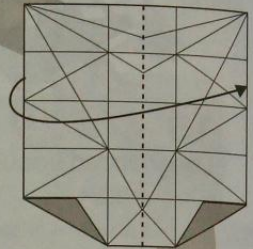

11) 半分に折ります

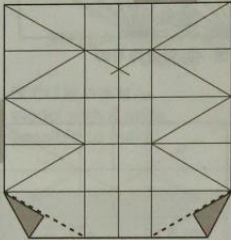

8) 角を折り込みます

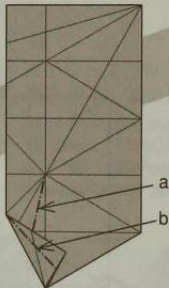

14) a: 折りすじをつけます
b: つぶすように折ります



13) 図のように折ります

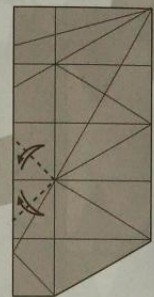

12) 折りすじをつけます

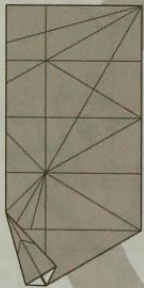

15) 全体を開きます

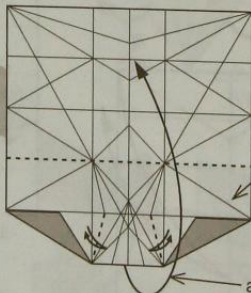

16) a: 折りすじをつけ
b: 図のように折ります

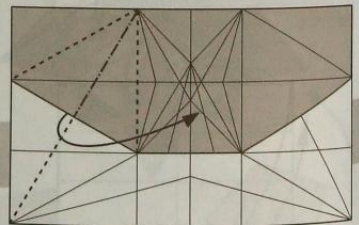

17) 開いて引き寄せるように

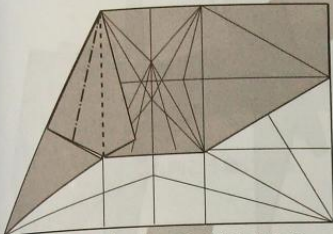

20) 山谷線に従ってつぶすように

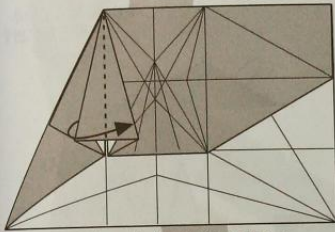

20) 一枚を右に開き変える

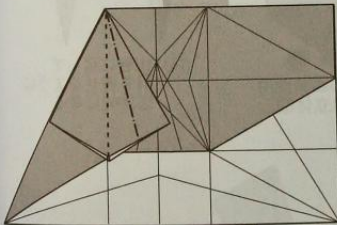

19) 山谷線に従ってつぶすように

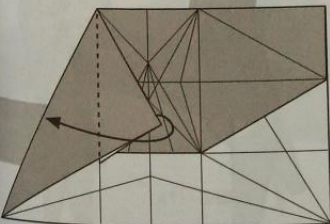

18) 一枚を左に開き変える

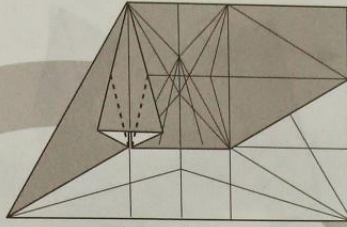

21) 折りすじをつける

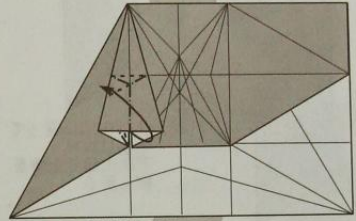

22) 山谷線に従って
引き上げるように

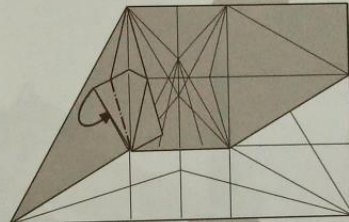

23) 角を細く折るように
中割り折り

24) 矢印の部分も
21-23 の要領で
折りまとめる

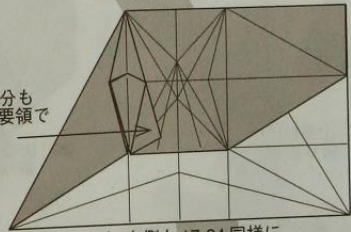

25) 右側も 17-24 同様に

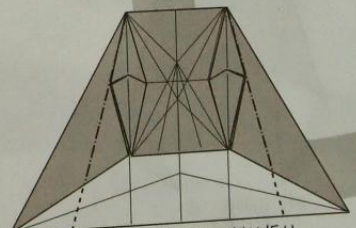

26) 山谷線に従って中割り折り

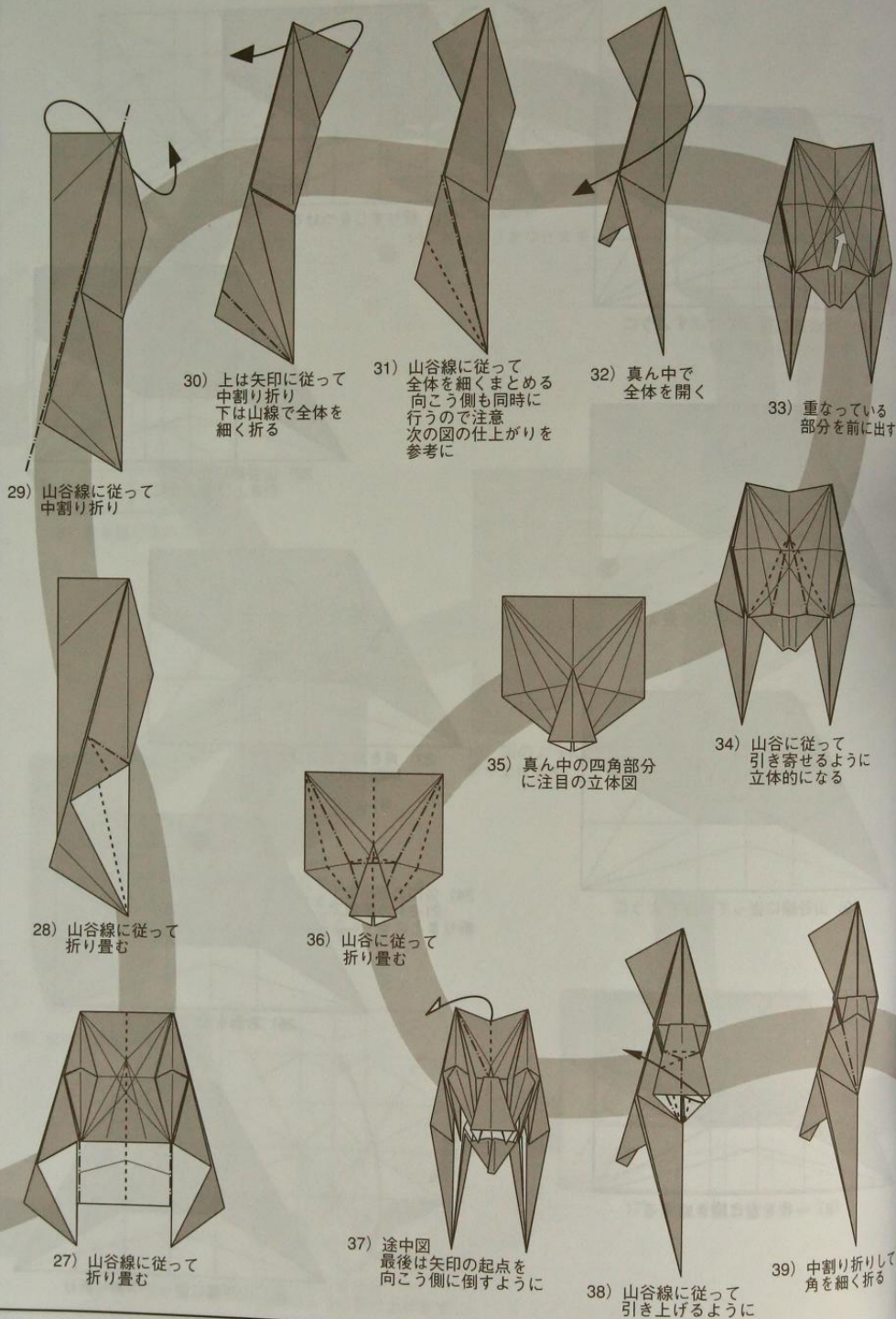

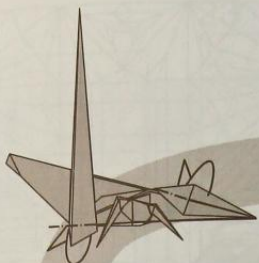

48) それぞれ向こう側に折る

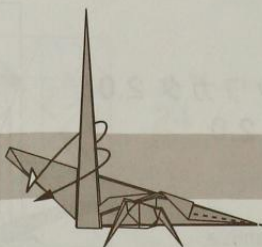

49) 後足をかぶせ折り
触覚を細く折る

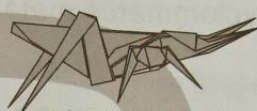

50) 足先を少し折って

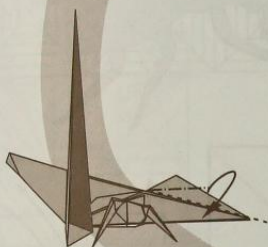

47) 頭は山谷に従って開くように
足は網掛け部分を closed sink

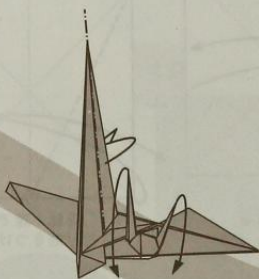

46) 前足、中足は
折り返し
後足は向こう側へ
細く折る



出来上がり

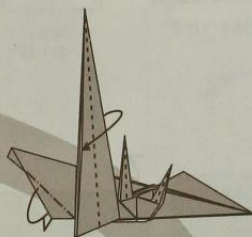

45) それぞれ山谷線に
従って細く折る



40) 山谷線に従って
開いてつぶすように

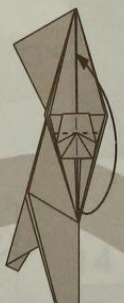

41) 谷線の
ところで
引き上げるように



42) 全体を
向こう側に折る

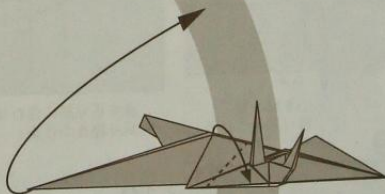

44) 長い角を引き上げるように



43) 矢印に従って
3カ所中割り折り

メタリフェルホソアカクワガタ 2.0

Cyclommatus metalifer 2.0

神谷哲史

Model & Diagrams by Satoshi Kamiya

作 2005/06/xx

図 2006/06/30

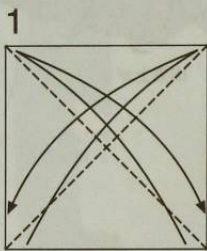
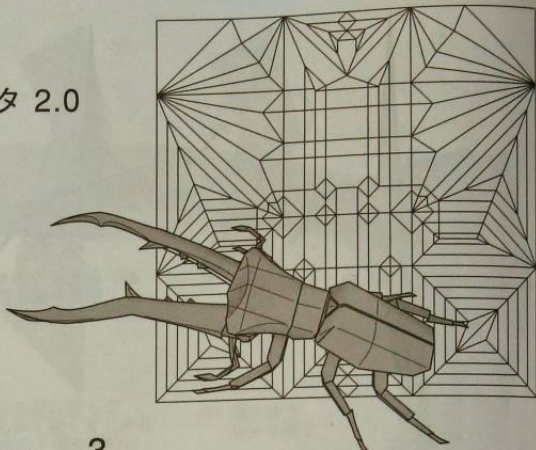

1 対角線に折り筋をつける

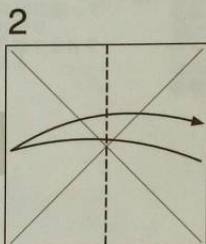

2 半分に折り筋をつける

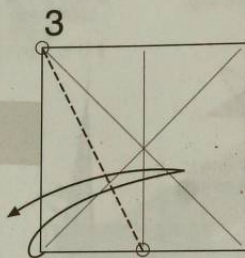

3 ○を結ぶ線で折り筋をつける

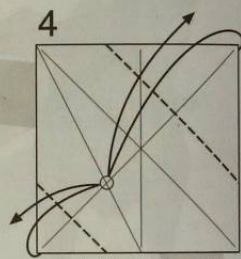

4 カドを○に合わせて折り筋をつける

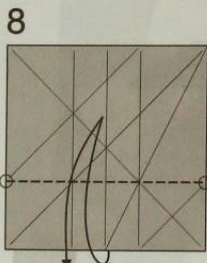

8 ○を結ぶ線で折り筋をつける

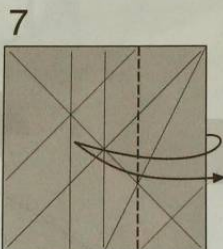

7 線を折り筋に合わせて折り筋をつける

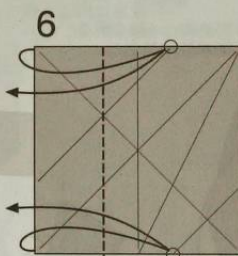

6 カドを○に合わせて折り筋をつける

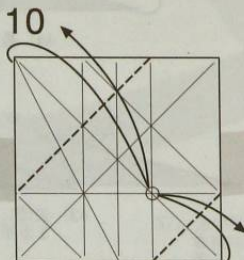
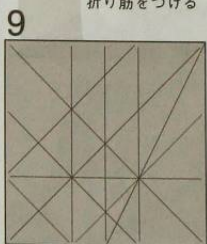
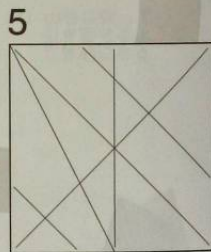

10 カドを○に合わせて折り筋をつける

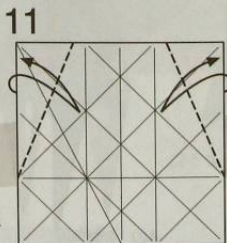

11 線を折り筋に合わせて折り筋をつける

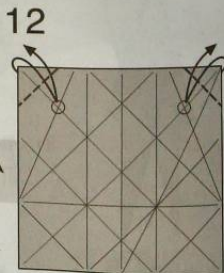

12 カドを○に合わせて折り筋をつける

22

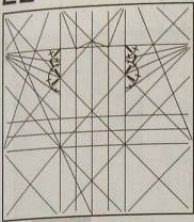

それぞれ半分の角度で
折り筋をつける

23

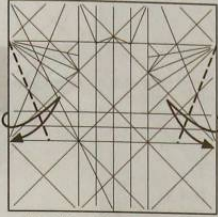

線を折り筋に合わせて
折り筋をつける

25

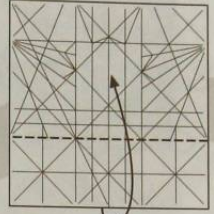

線をついている
折り筋で折る

21

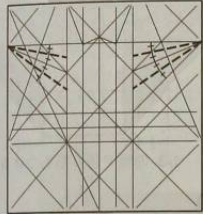

それぞれ半分の角度で
折り筋をつける

24

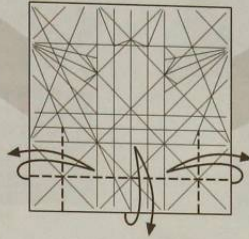

線を折り筋に合わせて
折り筋をつける

18

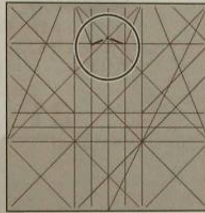

○を結ぶ線で
折り筋をつける

17

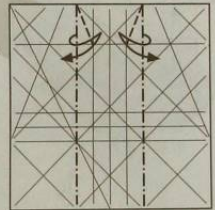

折り筋と折り筋をあわせて
折り筋をつける

20

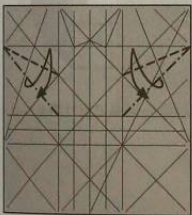

折り筋と折り筋をあわせて
折り筋をつける

19

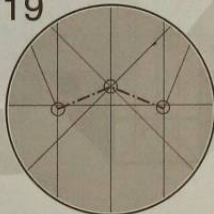

○を結ぶ線で
折り筋をつける
水平な折り筋とは
少しずれる

13

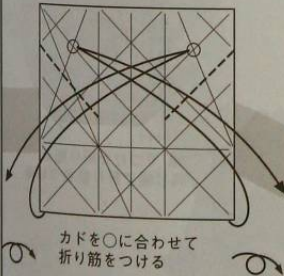

カドを○に合わせて
折り筋をつける

15

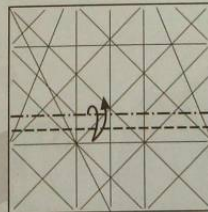

折り筋と折り筋をあわせて
折り筋をつける

14

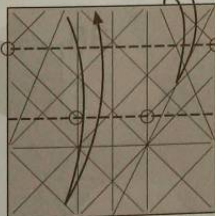

○を結ぶ線で
折り筋をつける

16

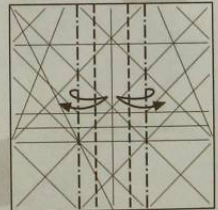

折り筋と折り筋をあわせて
折り筋をつける

26

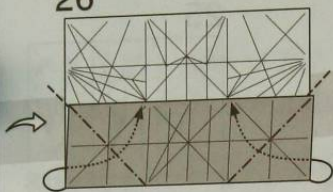

中割り折り

27

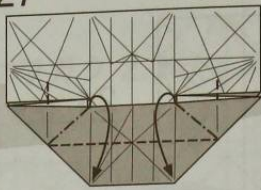

縁と縁を合わせて
起き上がってきた部分をつぶすように折る

28

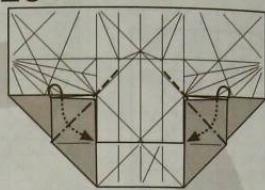

中割り折り

29

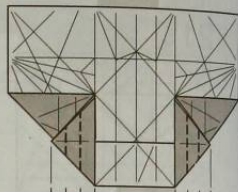

1/3 の幅で折り筋をつける

33

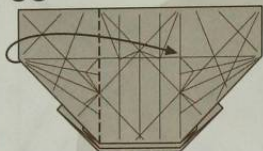

カドを反対側に折る

32

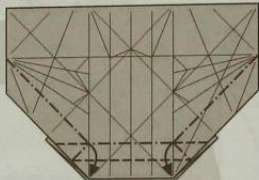

ついている折り筋を使って
中心の部分を持ち上げて
折り畳む

34

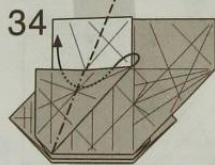

中割り折り

31

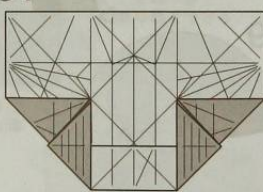

30

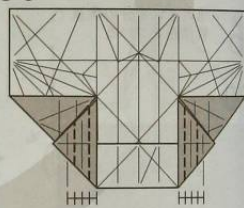

半分の幅で折り筋をつける

35

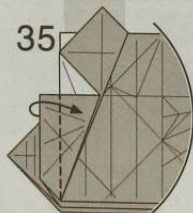

縁を反対側に折る

39

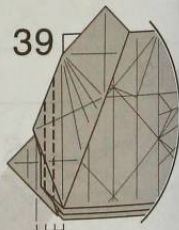

30 でつけた折り筋と
同じ幅で折り筋をつける

36

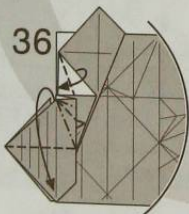

カドとカドを合わせて
起き上がってきた部分をついている折り筋を使って
折り畳む

37

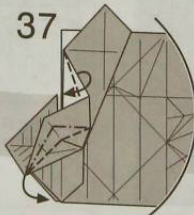

途中の図

38

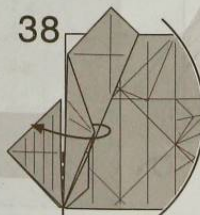

カドを反対側に折る

48

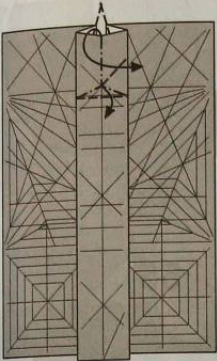

ついている折り筋で
中心線をつまむようにして
折り畳む



47

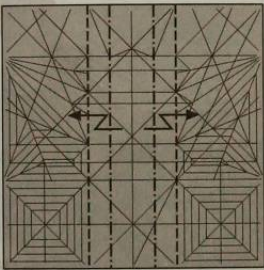

ついている折り筋で
段折り

49

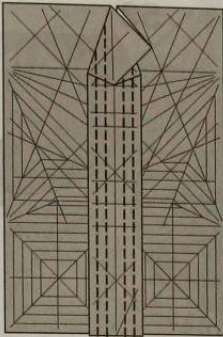

1/3 の幅で
折り筋をつける

50

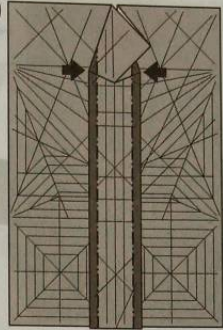

沈め折り
(Open sink)

46

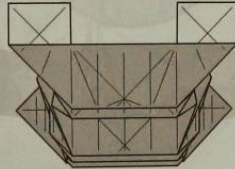

全部広げる

45

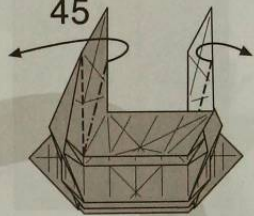

途中の図

40

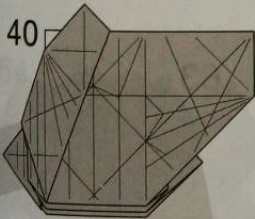

反対側も 33-39 と
同じように折る

41

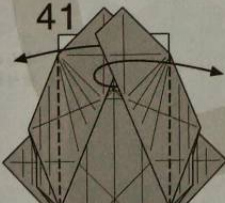

カドを反対側に折る

42

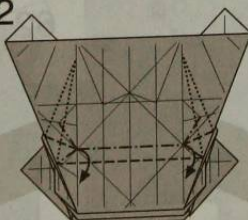

ついている折り筋を使って
中心の部分を持ち上げて
折り畳む

43

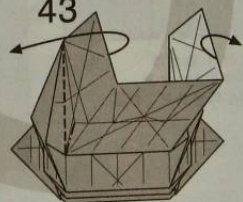

途中の図

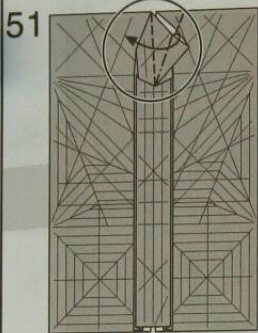

内側を広げて
つぶすように折る

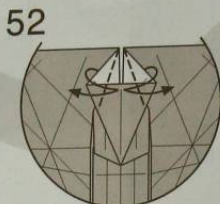

縁を中心に合わせて
折り筋をつける

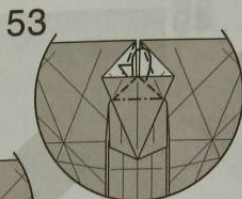

つけた折り筋を使って
フチを内側に折り込む

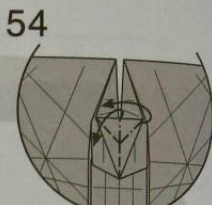

縁を中割り折り
するようにしながら
半分にする

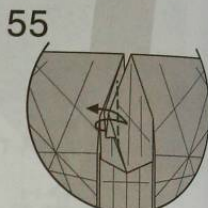

縁を折り筋に合わせて
折り筋をつける

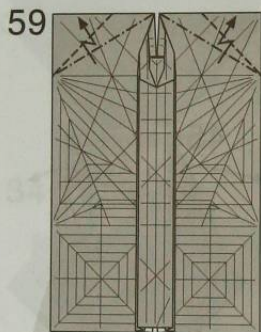

段折り

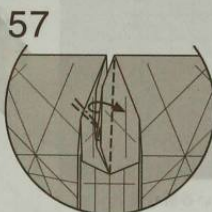
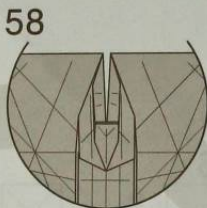

縁を反対側に折って
起き上がった部分をつぶすように折る

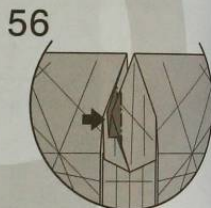

沈め折り
(Open sink)

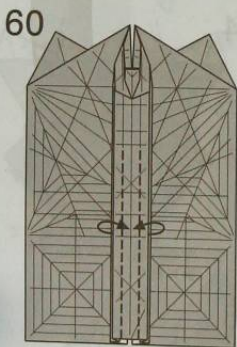

上の1枚だけ
半分くらいまで
中心に合わせて折る

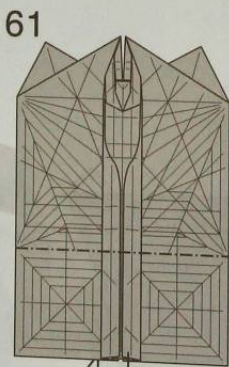

縁を後ろへ折る

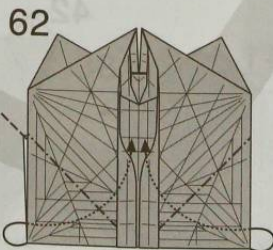

中割り折り

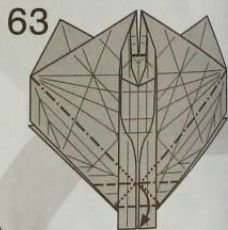

ついている折り筋を使って
中心の部分を持ち上げて
折り畳む

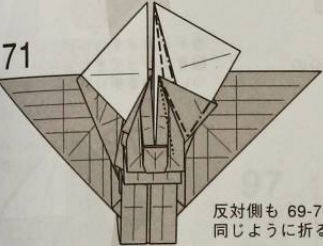
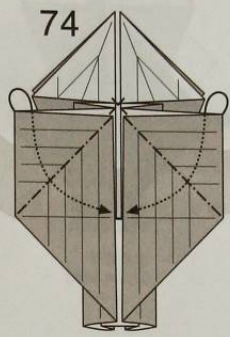
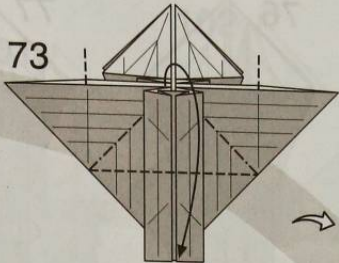
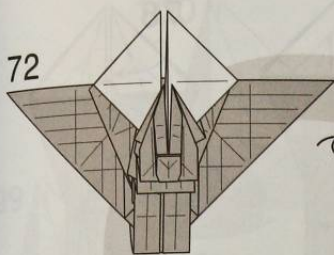

反対側も 69-70 と
同じように折る

縁と縁を合わせて
起き上がった部分をつぶすように折る

中割り折り

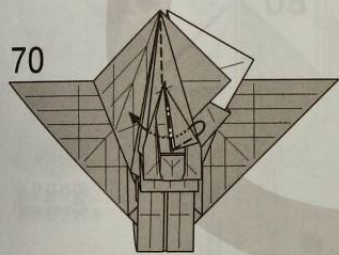

中割り折り
するように折る

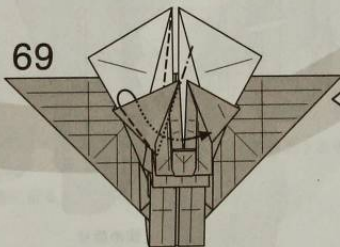

中割り折り
するように折る

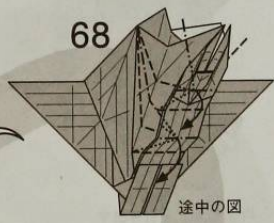

途中の図

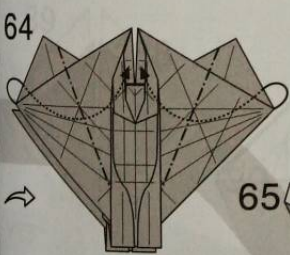

中割り折り

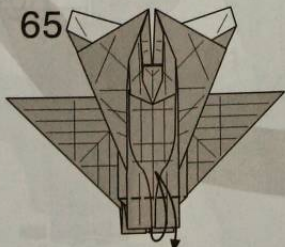

いっぱいところで
折り筋をつける



縁を両側に広げて
つぶすように折る

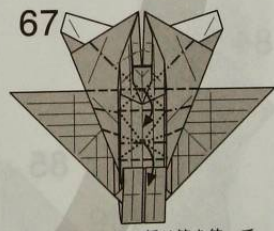

ついている折り筋を使って
中心の部分を持ち上げて
折り畳む

75

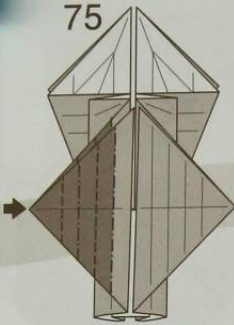

沈め折り
(Open sink)

76

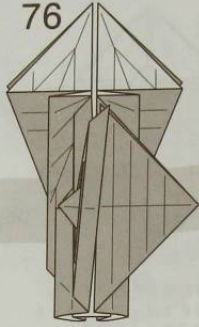

反対側も 75 と
同じように折る

77

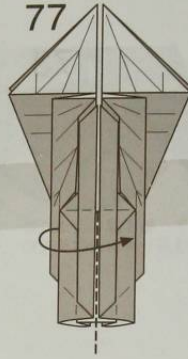

沈め折りした部分の
次の隙間を開く

78

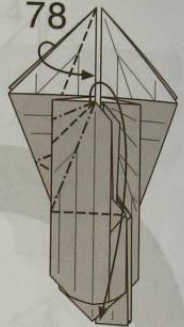

カドとカドを合わせて
起き上がった部分をつ
いている折り筋で折り畳む

79

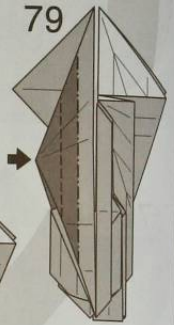

沈め折り
(Open sink)

83

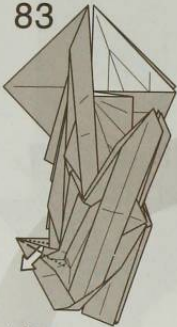

内側のカドを引き出す

82

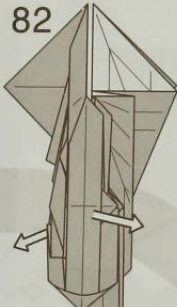

かるく広げる

81

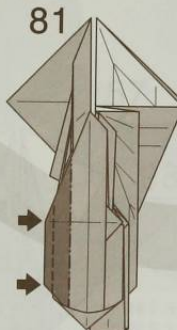

沈め折り
(Open sink)

80

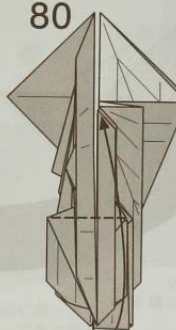

カドを上にする

84

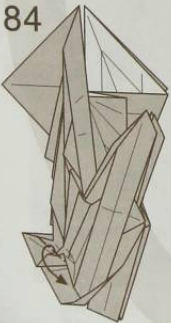

たんでいるヒダを
下に折る

85

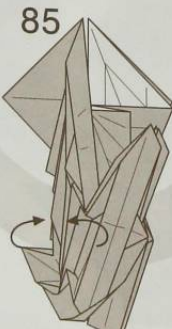

平らに折り畳む

86

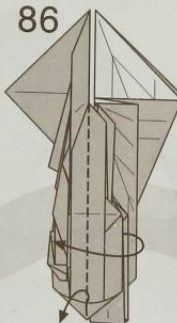

閉じる

87

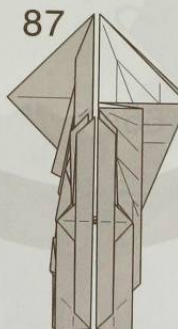

反対側も 77-86 と
同じように折る

88

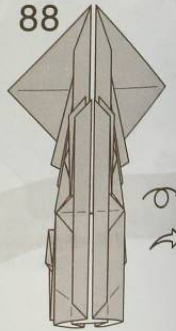



99
カドが少し
出るように折る



100
戻す



101
中割り折り



102
カドをつまむようにして
内側に段折り

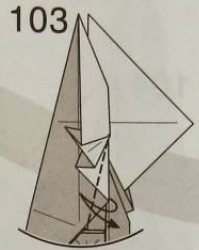

103
カドを折り筋に合わせて
折り筋をつける

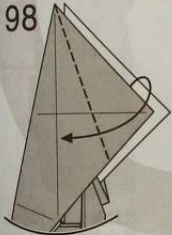

98
縁を折り筋に
合わせて折る

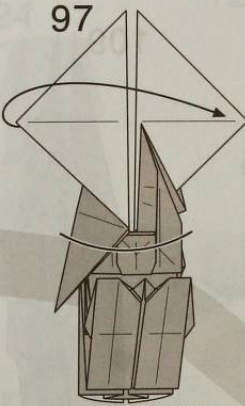

97
カドを反対側に折る

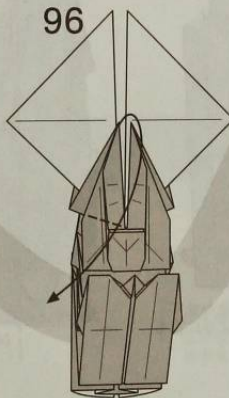

96
カドを反対側に折る



95
縁を戻して
平らに折り畳む

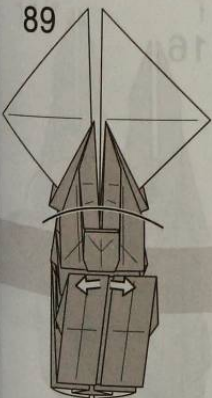

89
ヒダを引き出す



90
■の部分をつぶしながら
平らに折り畳む



91
途中の図

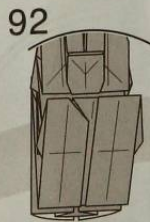

92
反対側も89-91と
同じように折る

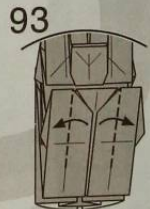

93
縁をかるく開く

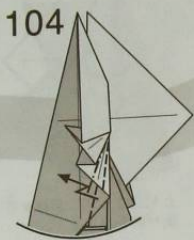

ずらすようにして
折ったカドが
出るように段折り



カドを斜めに折る



後ろの隙間へ
折り込む

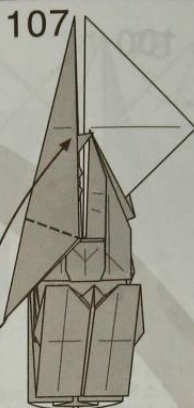

カドを上にする

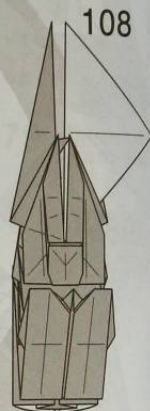

反対側も 96-107 と
同じように折る

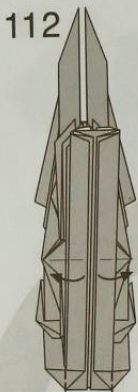

縁を反対側に折る

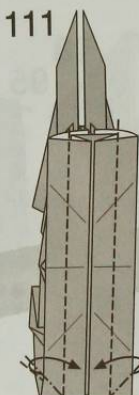

縁を中心に合わせて
引き寄せるように折る



カドを上にする

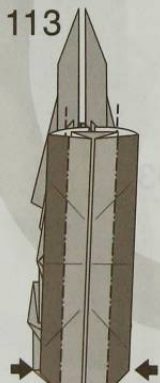

沈め折り
(Closed sink)

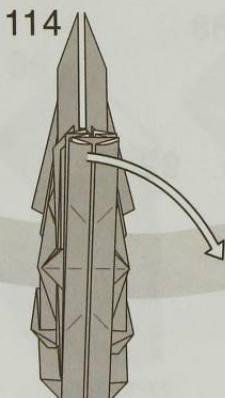

軽く広げる

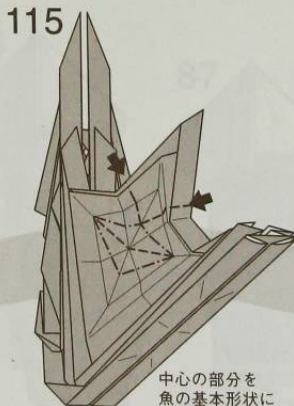

中心の部分を
魚の基本形状に
折り畳む

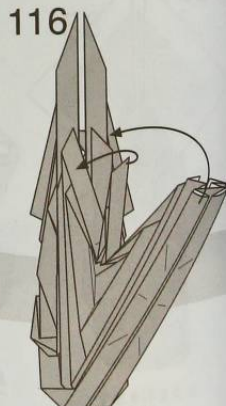

途中の図

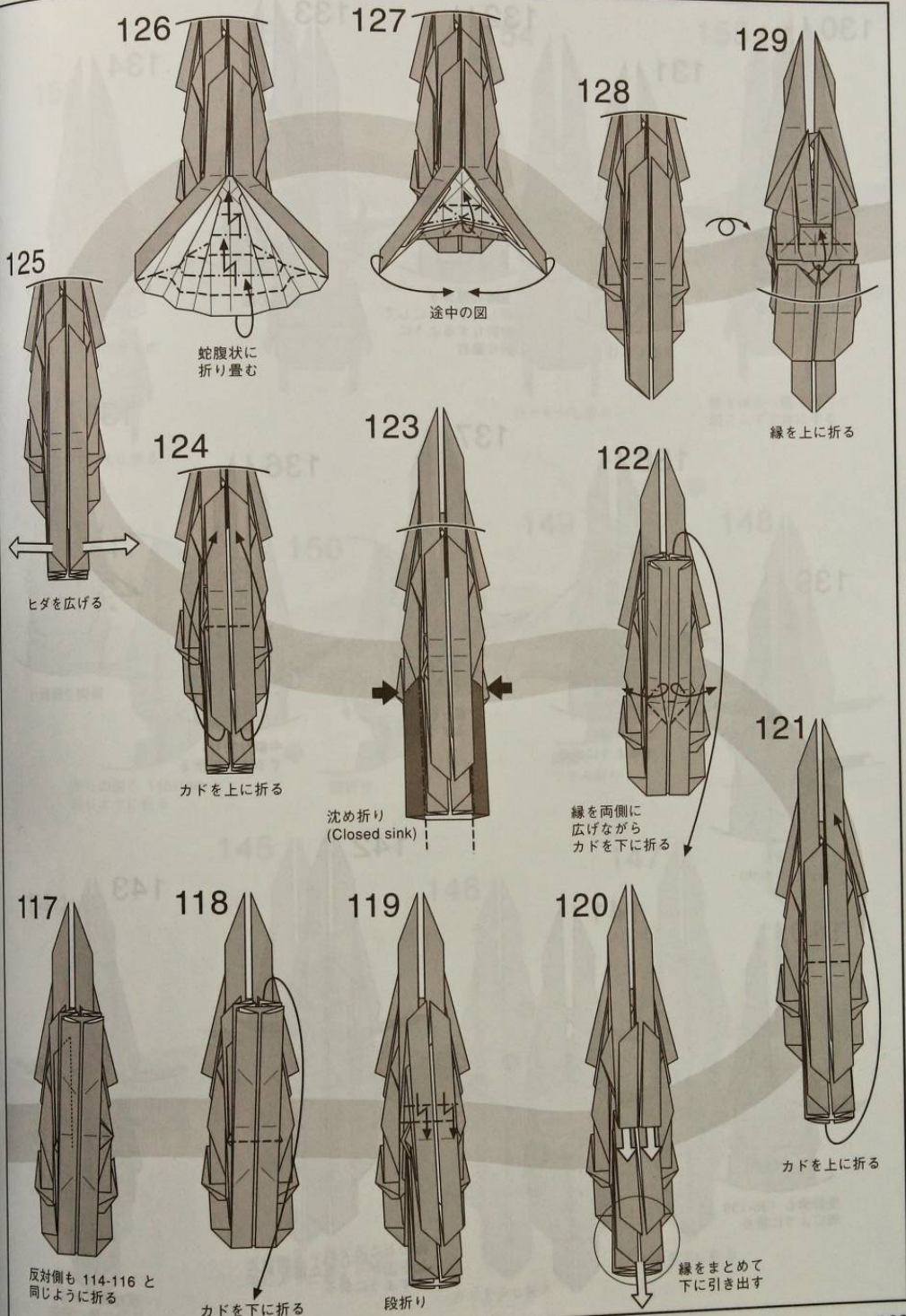

130

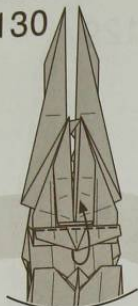

カドを上折る

131

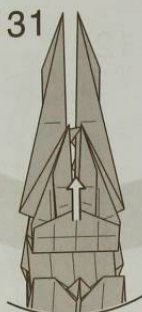

かるく広げる

132

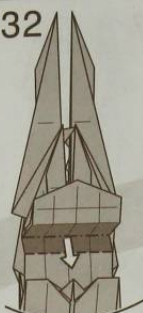

■の部分
押し出すようにして
段折りするように
折り畳む

133

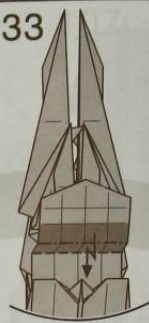

途中の図

134

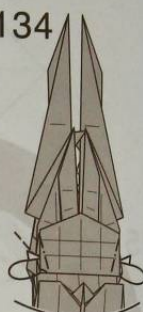

カドを内側へ折り込む

138

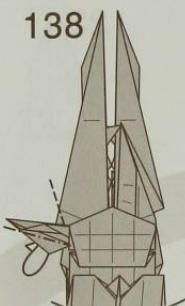

中割り折り
するように折る

137

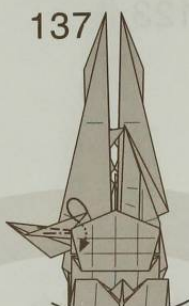

中割り折り
するように折る

136

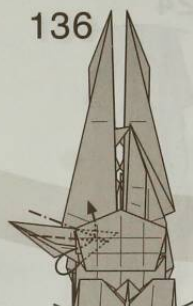

中割り折り
するように折る

135



両側で段折り

139

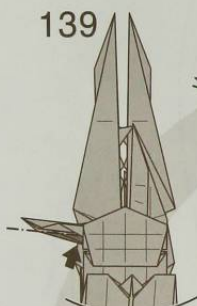

沈め折り
(Open sink)

140

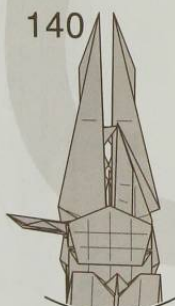

反対側も 135-139 と
同じように折る

141

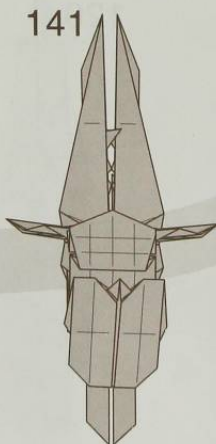

142

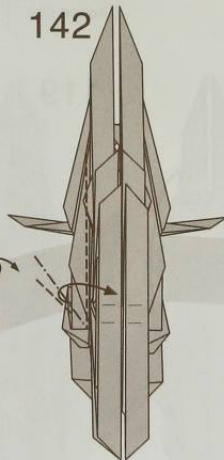

縁のところまで折って
起き上がった部分をつ
ぶすように折る

143

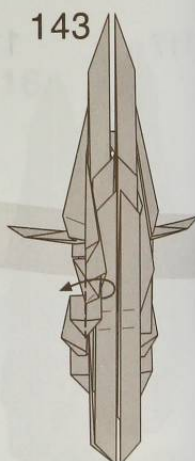

反対側に折る

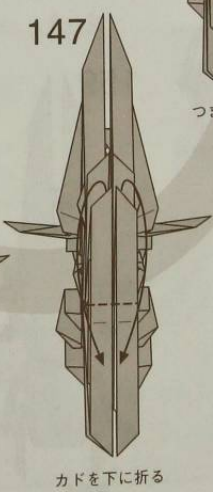
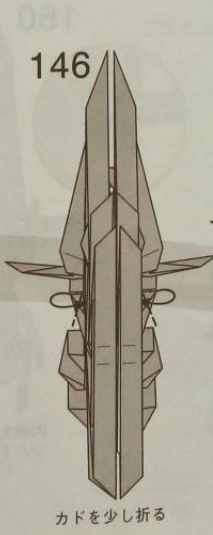
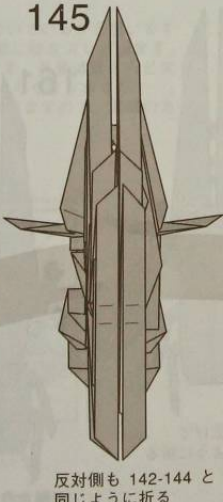
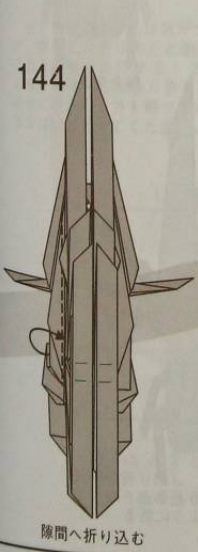
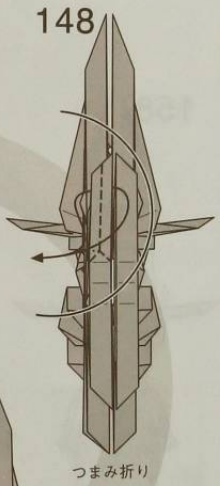
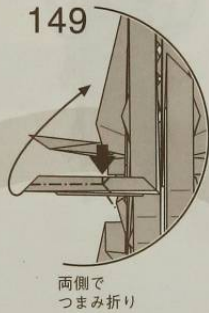
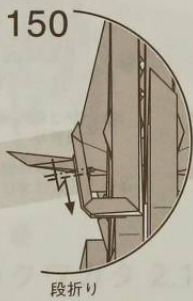
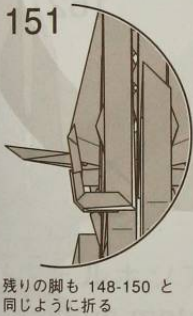
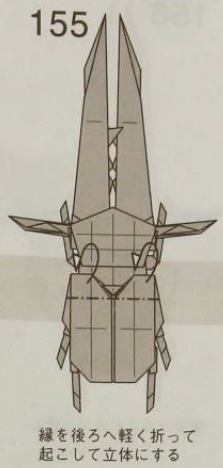
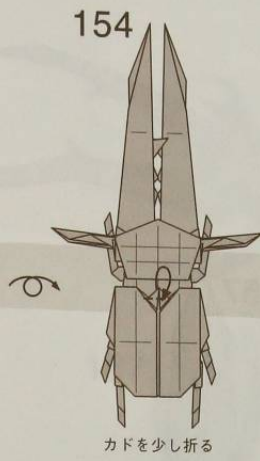
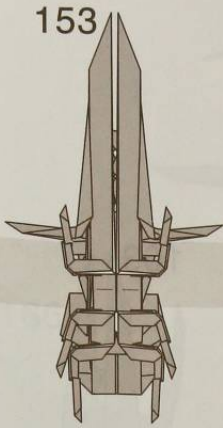
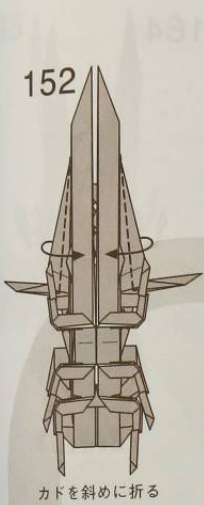

156

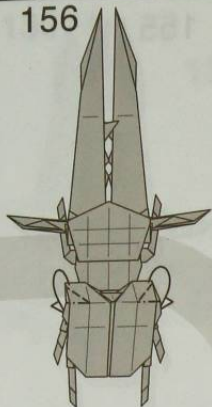

後ろへつまむように折る

157

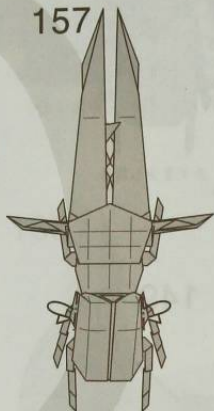

カドを後ろへ折って留める

163

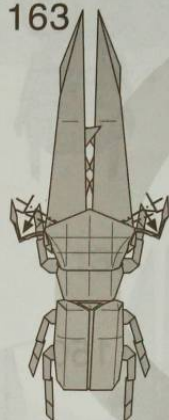

アゴのカドを段折り

164

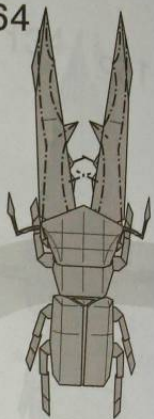

アゴを仕上げる

162

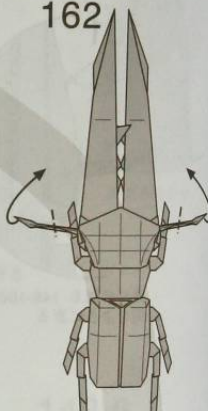

触角を上へ折る

158

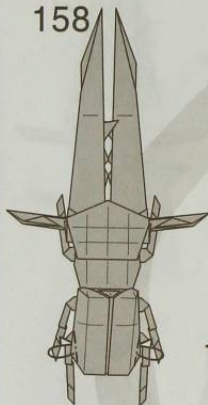

カドを後ろへ折る

160



159

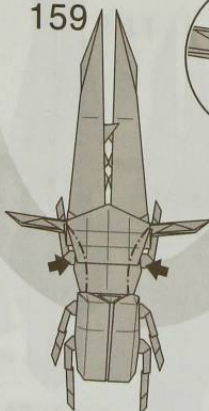

胸部を立体的にする

161

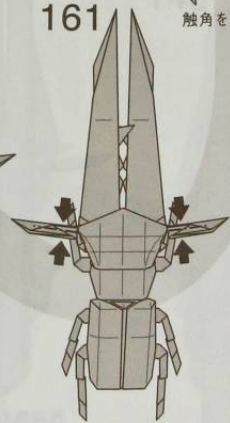

触角のカドをつまむように折る

内側を広げてつぶすように折る

165



後ろへ軽く折る

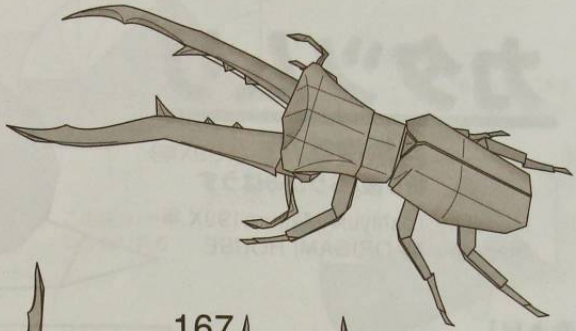

166

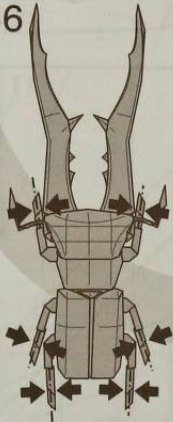

脚の先を
つまむように折る

167

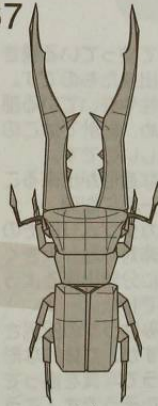

完成

メタリフェルホソアカクワガタ 2.1 Cyclommatus metalifer 2.1

さて、気になる人は気がついているかと思いますが、実はこの折り方だと頭部に妙なズレが出ます。これを調整したのが 2.1 です。外見はほとんど変わらないうえにかなり折りにくくなりますが……。参考に折り出し方を載せておきますので、興味のある方は試してみてください。

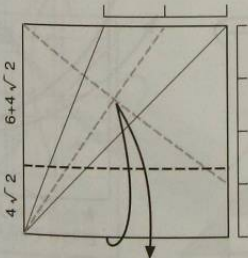

一辺 $4+8\sqrt{2}$ という
比率の折り出し。
3 という数の出し方に注目。

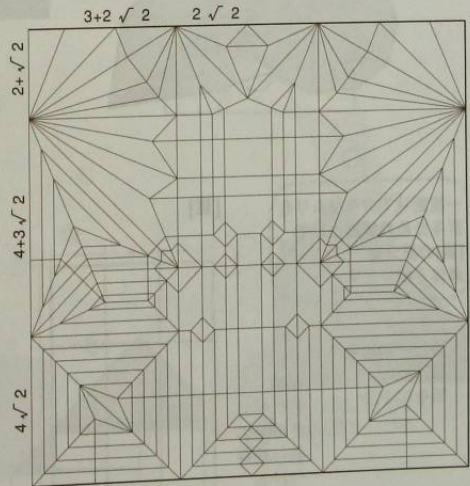

カタツムリ

目黒俊幸/作 (199X年)
折り図/おりがみはうす

Model by Toshiyuki Meguro 199X 年
Diagrams by ORIGAMI HOUSE

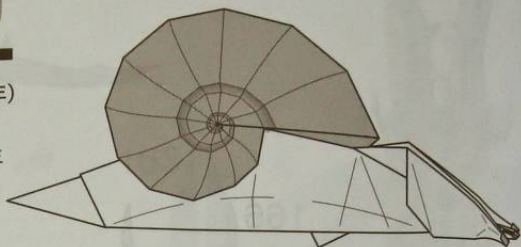

【巻き貝】

カタツムリの一部として使っている巻き貝は適当に折っていたら出来たものです。立体的な形や左右非対称性や巻いている部分の見立てなどがあるため、設計ではこのような形を得ることは難しいのです。

しかし一たび、このような造形が出来ることが解るとそれを設計の一部に取關 1 展させるのは容易です。カタツムリはその様にして作ったのですが非対称性が大きくて一直分子としてきれいに分解出来るような設計図には出来ませんでした。

なお、この図はおりがみはうすの田尻さんに描いてもらったのですが、立体的な形を描くのにデジタルカメラで写真を撮ってパソコン上で書きされたそうです。こういう事って現代的ですよー。(1998年5月現在)

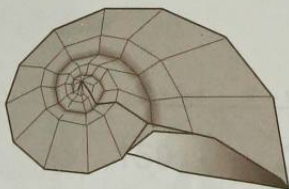
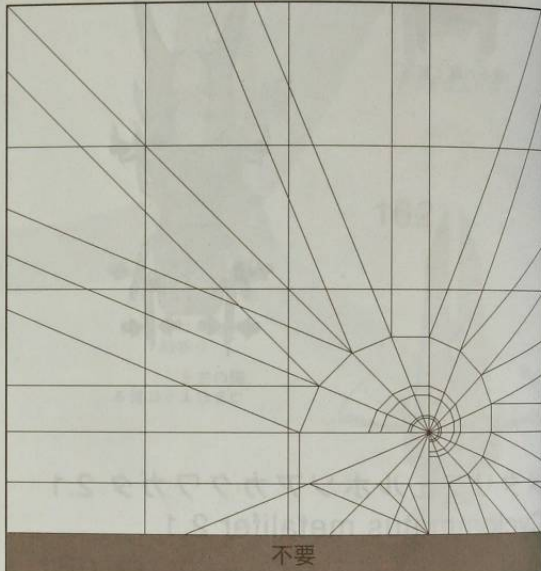

一枚折りでカタツムリを折るための練習として [貝]の部分を単体で折ります

【貝】

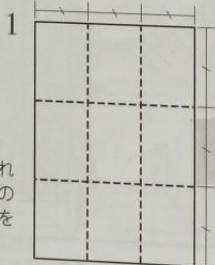

コピー用紙等の長方形の紙をつかう

縦横それぞれ3等分の折り筋をつける

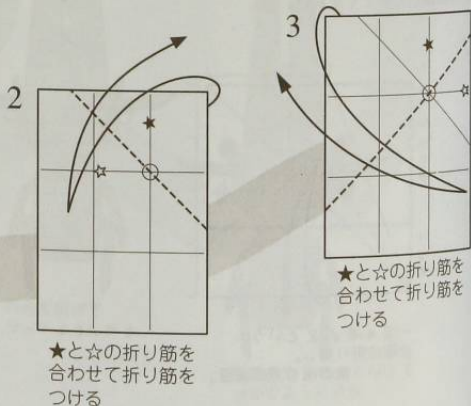

★と☆の折り筋を合わせて折り筋をつける

★と☆の折り筋を合わせて折り筋をつける

ついている
折り筋の線OAを
交点の中心OBに
合わせて
斜めに段折り

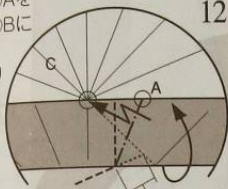

12

引き連れてきた部分は
Cの折り筋のところまで
つぶすように折る

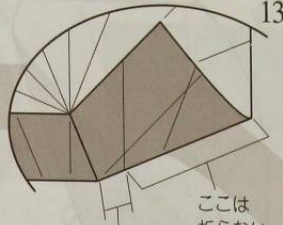

13

この部分だけ
しっかり折る

ここは
折らない

同じようにして
ついている折り筋OAを
交点の中心OBに
合わせて
斜めに段折り

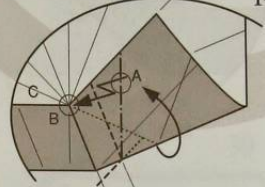

14

引き連れてきた部分は
Cの折り筋のところまで
つぶすように折る

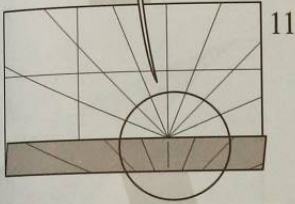

11

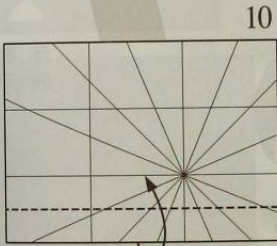

10

折り筋に
合わせて折る

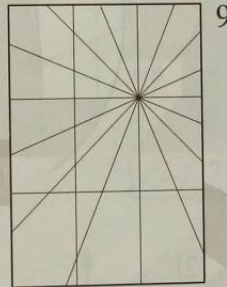

9

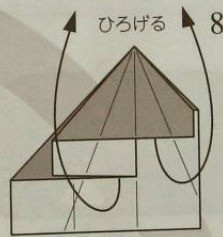

ひろげる

8

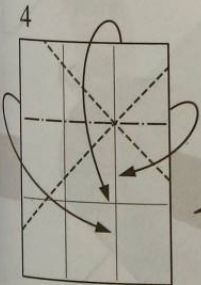

4

つけた折り筋で
折りまとめる

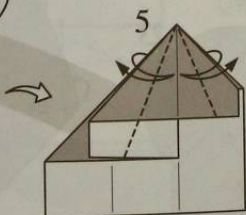

5

折り筋に合わせて
折り筋をつける

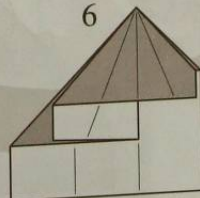

6

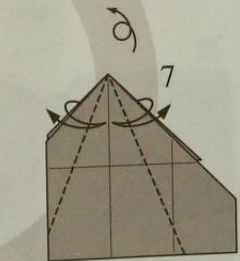

7

折り筋に合わせて
折り筋をつける

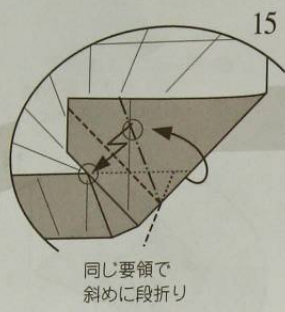

同じ要領で斜めに段折り



同じ要領で斜めに段折り

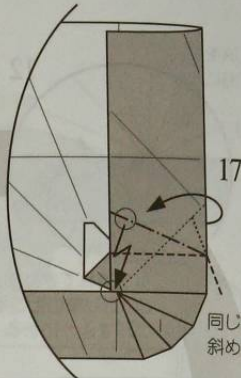

同じ要領で斜めに段折り

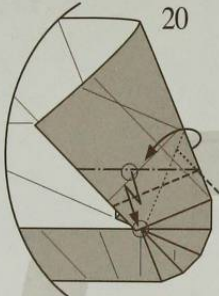

同じ要領で斜めに段折り

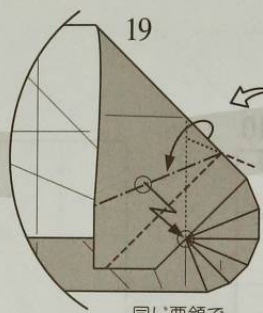

同じ要領で斜めに段折り

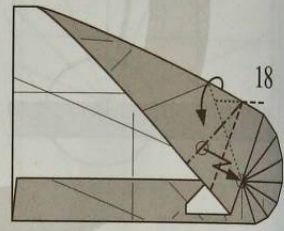

同じ要領で斜めに段折り

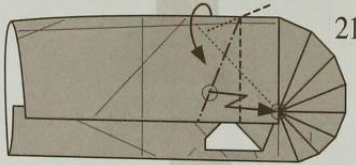

同じ要領で斜めに段折り

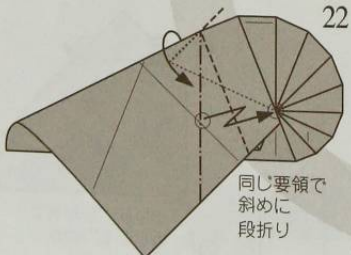

同じ要領で斜めに段折り

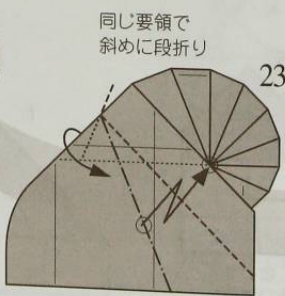

同じ要領で斜めに段折り

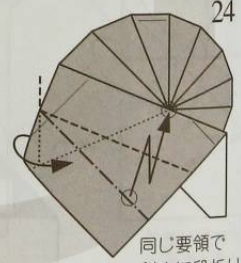

同じ要領で斜めに段折り

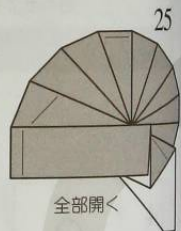

全部開く

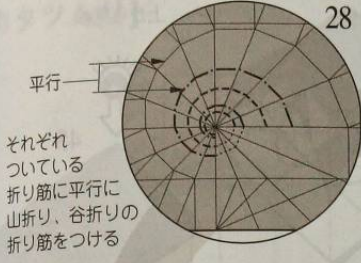

それぞれ
ついている
折り筋に平行に
山折り、谷折りの
折り筋をつける

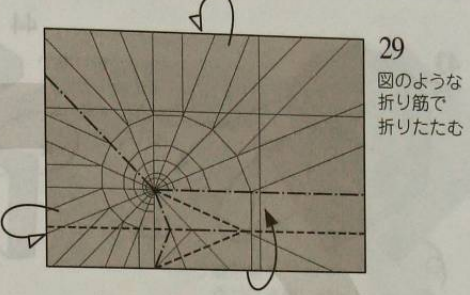

図のような
折り筋で
折りたたむ

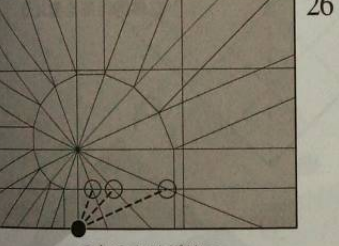
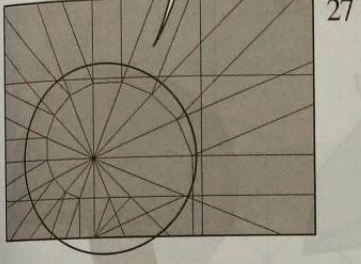

●と○を結ぶ線で
折り筋をつける

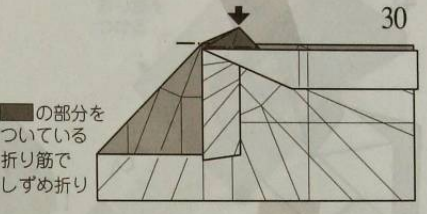

■の部分をついている
折り筋で
しずめ折り

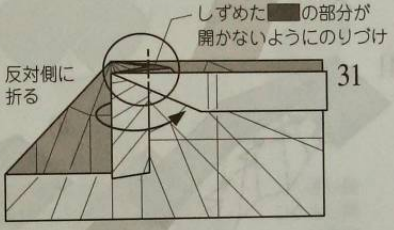

しずめた■の部分が
開かないようにのりづけ
反対側に
折る

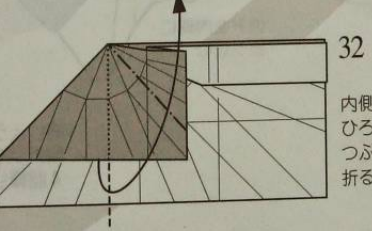

内側を
ひろげて
つぶすように
折る

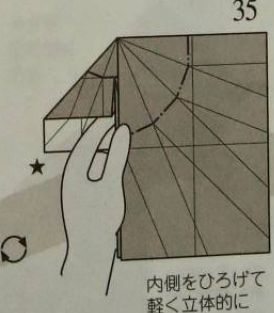
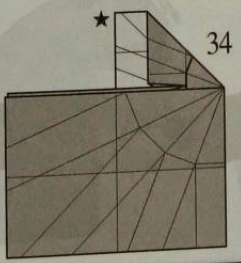
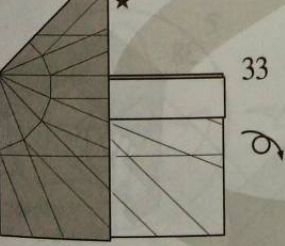

内側をひろげて
軽く立体的に
する



43
○と○を結ぶ線で
折り筋をつける

44
つけた折り筋で
★のカドから
内側に全部
折り込む

上から見る
45

42

47
できあがり

46
26でつけた折り筋で
立体的に形を整える

41
残りも
同じように
段折り

40
カドを内側に
折り込む

39
同じように
段折りを
4回繰り返す

36
ついている
折り筋で
斜めに段折り

37
同じように
3回段折りを
繰り返す

38
カドを内側に
折り込む

[カタツムリ]

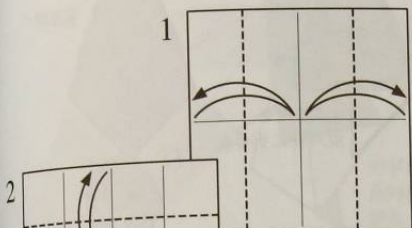

1

折り筋に合わせて
折り筋をつける

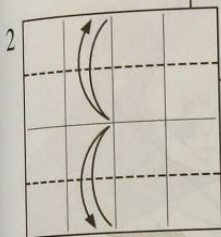

2

折り筋に合わせて
折り筋をつける

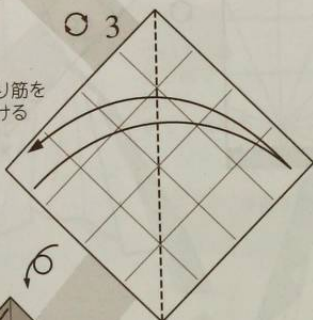

3

折り筋を
つける

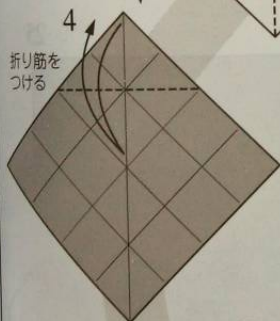

4

折り筋を
つける

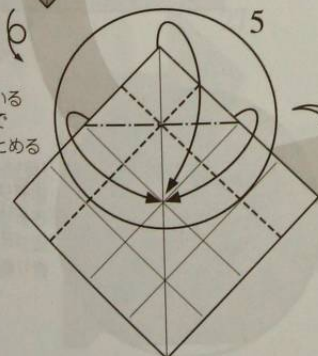

6

ついている
折り筋で
折りまとめる

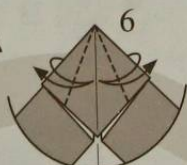

6

折り筋をつける

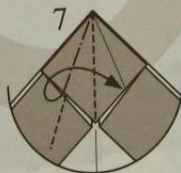

7

内側を
ひろげて
つぶすように
折る

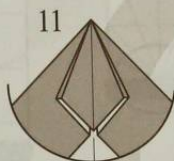

11

6



10

上の1枚を
反対側に
折る



9

内側を
ひろげて
つぶす
ように折



8

カドを
反対側に
折る

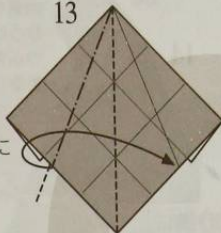

13

内側を
ひろげて
つぶすように
折る

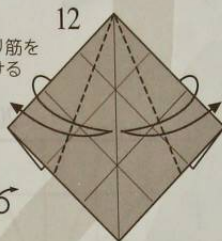

12

折り筋を
つける

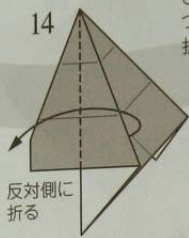

反対側に折る

内側をひろげてつぶすように折る

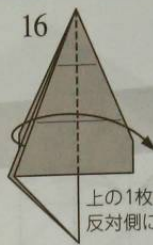
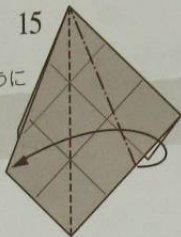

上の1枚を反対側に折る

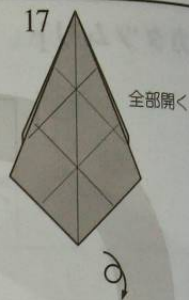

全部開く

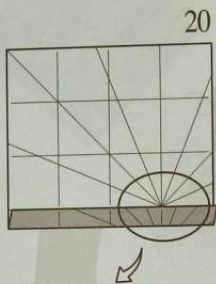

20

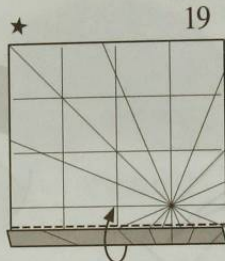

19

折り筋に合わせて折る

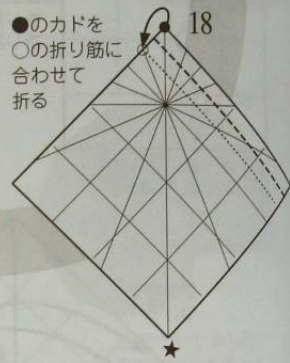

18

●のカドを○の折り筋に合わせて折る

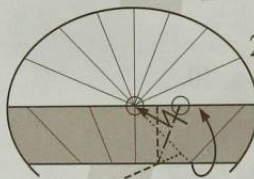

21

[貝]の11~22と同じように折る

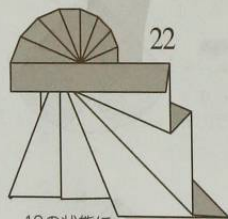

22

19の状態に戻す

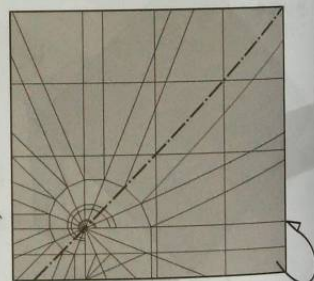

25

ついている折り筋で後ろへ折る

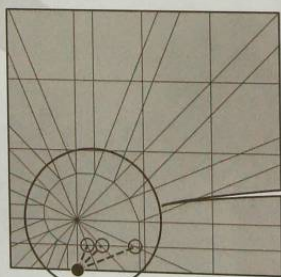

23

●と○を結ぶ線で折り筋をつける

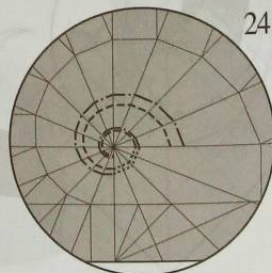

24

[貝]のときよりも山折り線を谷折り線に近づけるように折り筋をつける





ついている
折り筋で
斜めに段折り



下の縁に
沿って
カドを折る



つけた折り筋で
折りまとめる



○と○を結ぶ線で
折り筋をつける



水平に
折り筋をつける



○と○を結ぶ線で
折り筋をつける

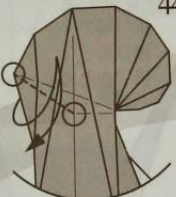

○の部分を
内側から
押し上げる



42でつけた
折り筋で
貝の部分
折り上げる



縁と縁を
合わせて
内側を
ひろげて
つぶす
ように折る



カドをつまんで
紙の重なりを
引き出す



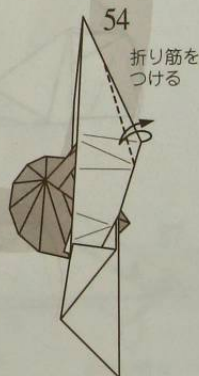
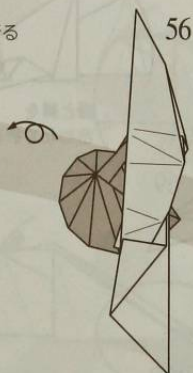
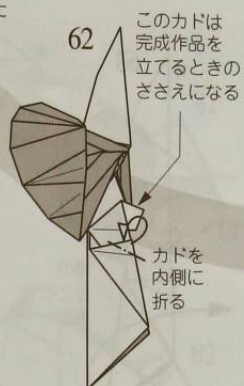

64

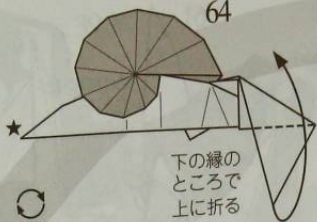

下の縁の
ところで
上に折る

65

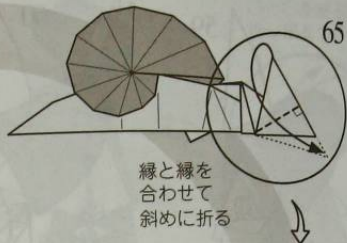

縁と縁を
合わせて
斜めに折る

63

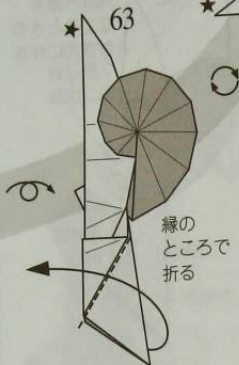

縁の
ところで
折る

66



カドを
斜めに折る

67

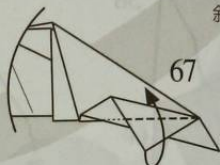

64と同じに
下の縁のところで
折り上げる

68



縁と縁を
合わせて折る

戻す

69



70

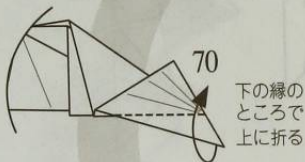

下の縁の
ところで
上に折る

71

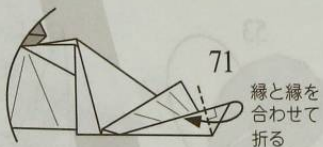

縁と縁を
合わせて
折る

75



戻す

72

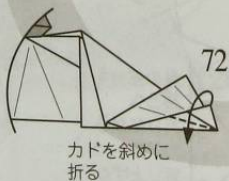

カドを斜めに
折る

73



下の縁に沿って
上に折る

74



縁と縁を
合わせて折る

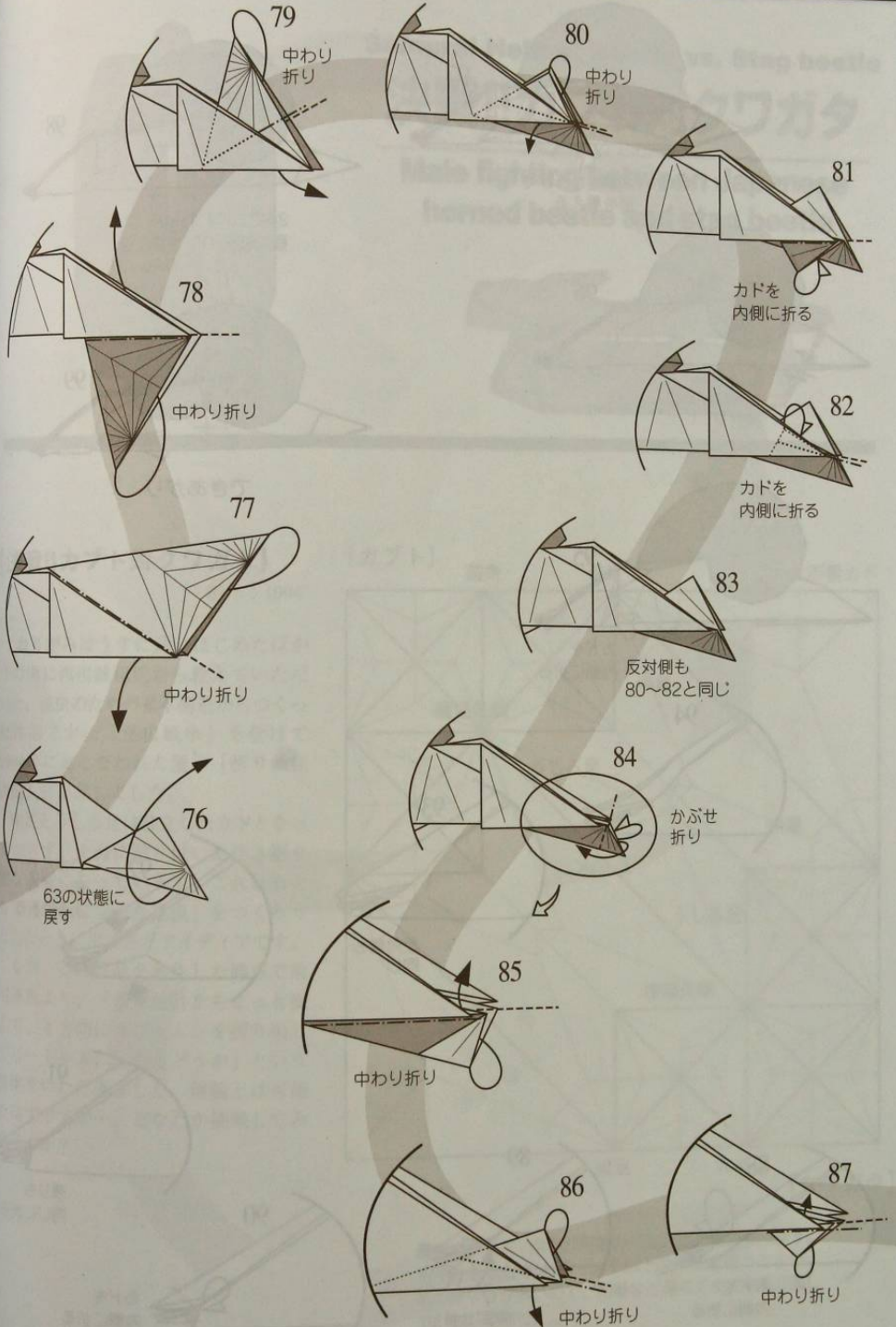

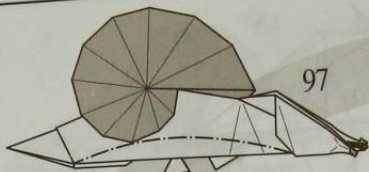

内側をひろげて
形を整える

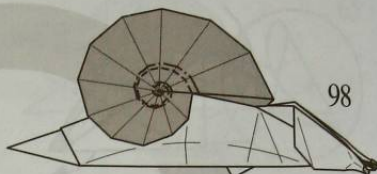

24でつけた折り筋で
貝の部分の形を整える

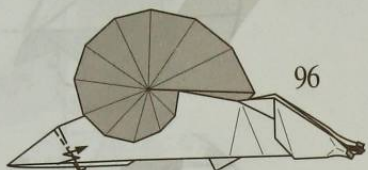

内側に斜めに
段折り

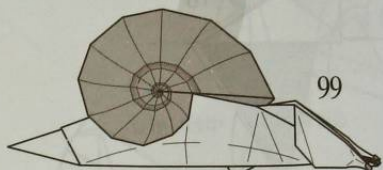

できあがり

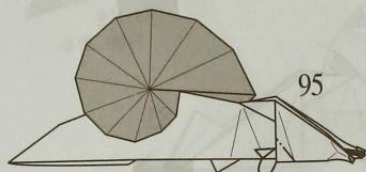

カドを
内側に折る

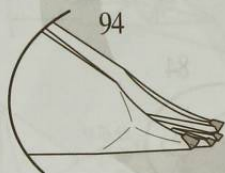

94

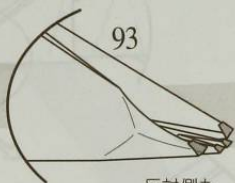

反対側も
同じ

93

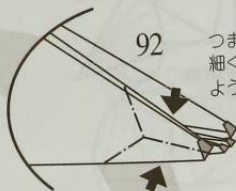

つまんで
細くする
ように折る

92

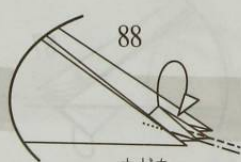

カドを
内側に折る

88



かぶせ折り

89

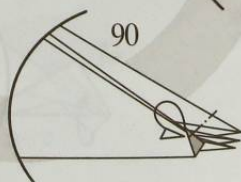

カドを
内側に折る

90



残りも
同じに折る

91

Samurai Helmet Beetle vs. Stag beetle 決戦!!カブト対クワガタ

Male fighting between Japanese horned beetle and stag beetle

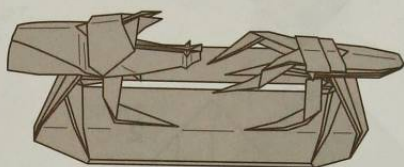
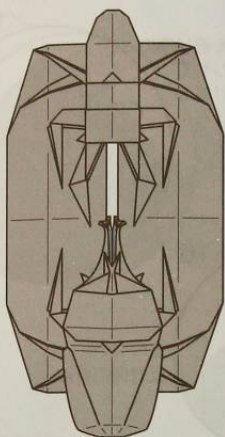

【決戦!!カブト対クワガタ】

創作：1994

おりがみはうすに通いはじめたばかりの頃に西川誠司氏から教えていただいた、昆虫のための基本構造からつくった作品です。「昆虫戦争」を受けて1994年におこなわれた展示「折り紙昆虫館」に出品しました。

中足とうしろ足は独立したカドとなっておらず、土台に貼り付いた浮き彫りの表現になっています。これはもともと「化石になった昆虫」をつくろうとしたときに出てきたアイデアです。

なお、この作品を創作した時点で前川淳氏より、「基本設計をちょっと変えて、4方向にカブトムシを折り出してビートルズにしたらどうか」という提案をいただきました。理論上は可能なのですが…。どなたか挑戦してみませんか？

【カブト】

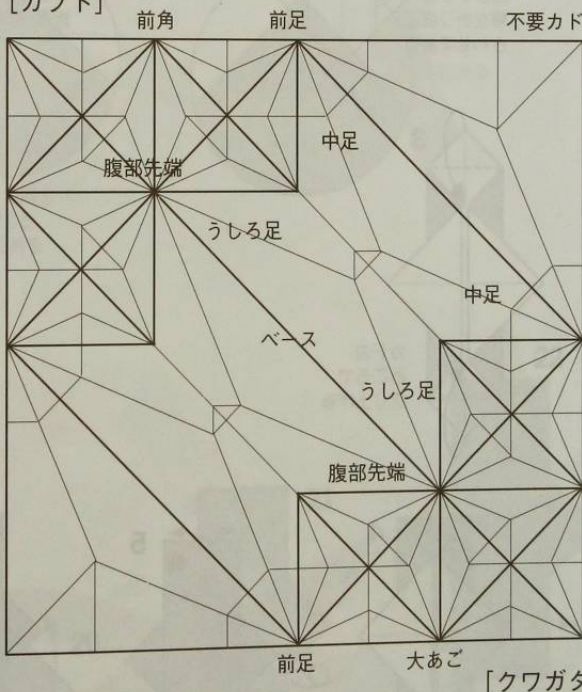

【クワガタ】

■完成サイズ：全長が用紙の一边の約35%になります。初めて折るときは35センチ以上の用紙を使うとよい。紙の重なりが多いので、和紙など薄くて丈夫な紙が適している。要糊付。

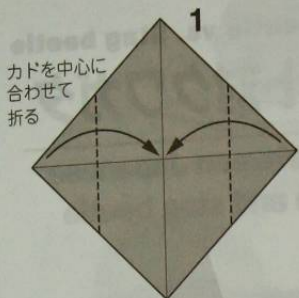

1
カドを中心に
合わせて
折る

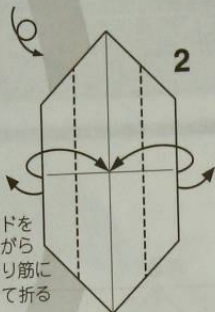

2
下のカドを
出しながら
縁を折り筋に
合わせて折る

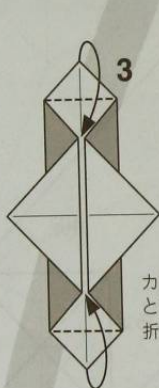

3
カドの
ところで
折り上げる

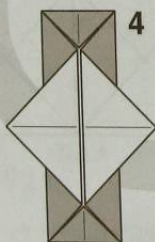

4

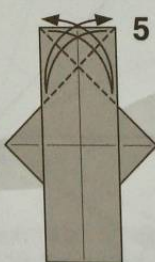

5

縁と縁を
合わせて折る

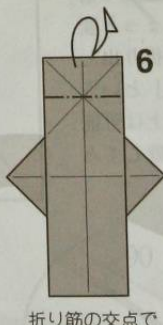

6

折り筋の交点で
後ろへ折って
折り筋をつける

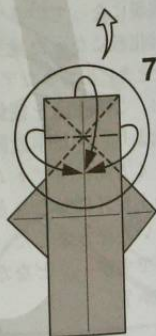

7

つけた折り筋で
折りまとめる

縁を折り筋に
合わせて
折り筋を
つける

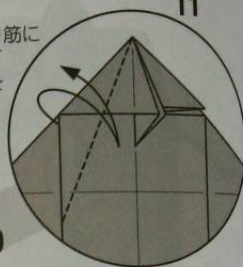

11

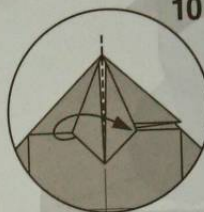

10

上の1枚を
反対側に折る

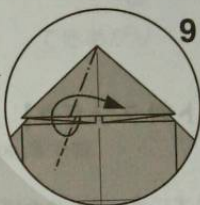

9

内側をひろげて
つぶすように
折る

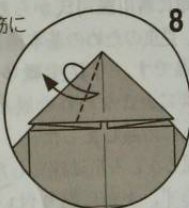

8

縁を折り筋に
合わせて
折り筋を
つける

内側をひろげて
つぶすように
折る

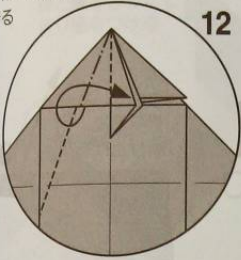

12

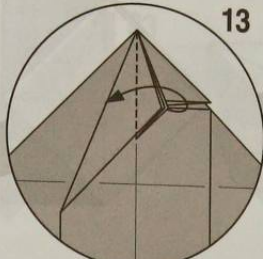

13

カドを3枚重ねて
反対側に折る

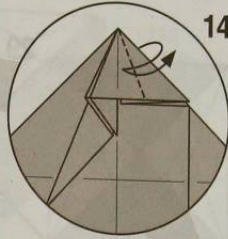

14

反対側も
8~13と同じ

内側を
ひろげて
つぶすように
折る

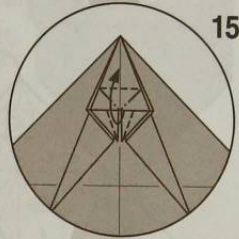

15

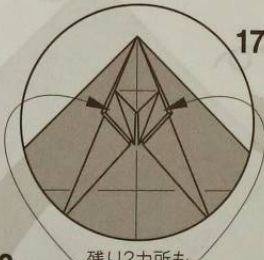

17

残り2カ所も
15~16と
同じに折る

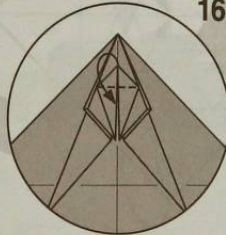

16

カドを
下に折る

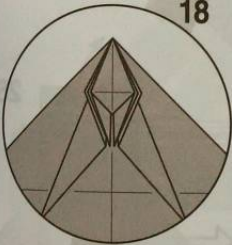

18

カドとカドを
粘ぶ線で
折り筋をつける

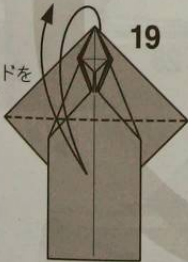

19

7の状態に
戻す



20

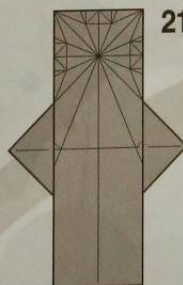

21

下側も
5~20と
同じに折る

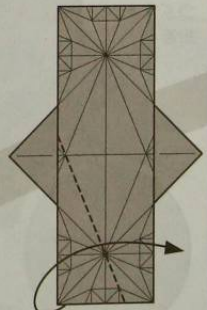

22

ついている
折り筋で折る

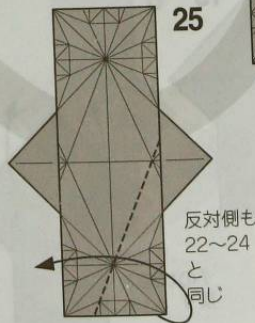
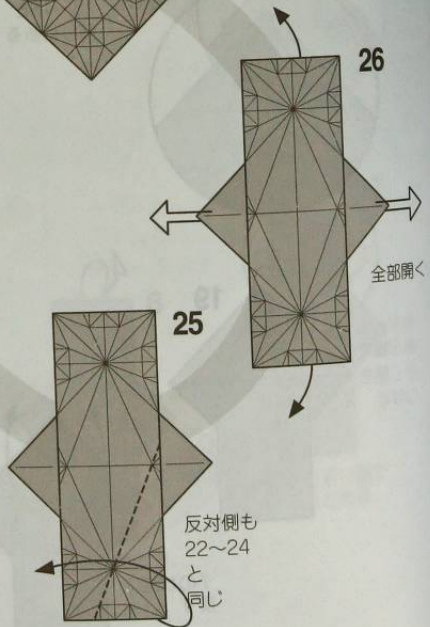
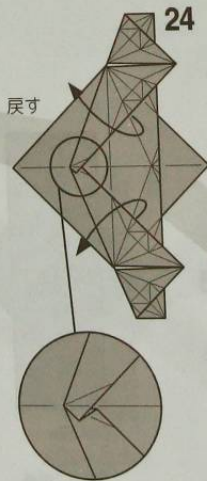
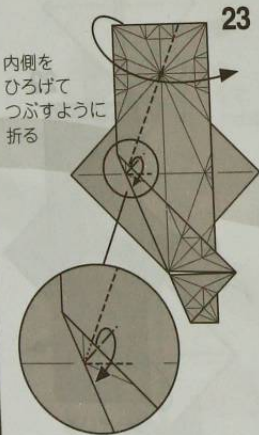
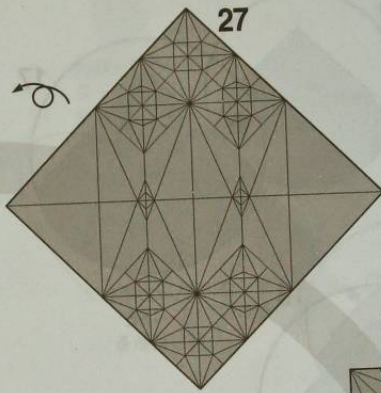
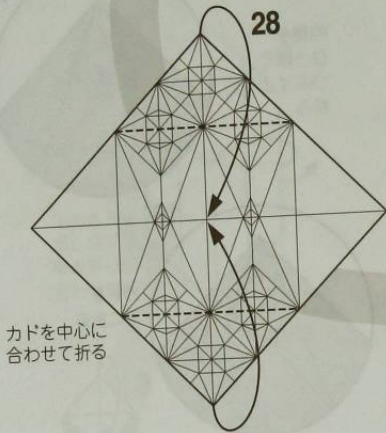
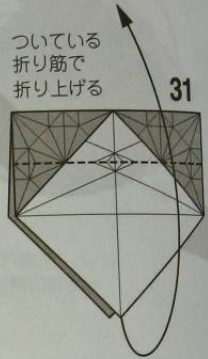
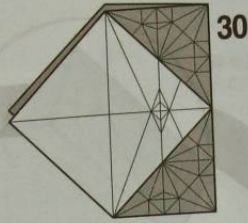
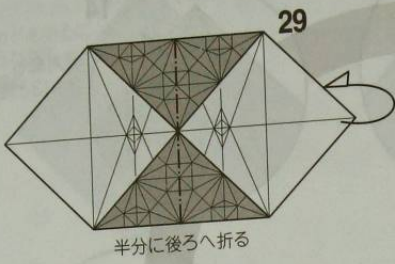

縁と縁を合わせて
折り筋をつける

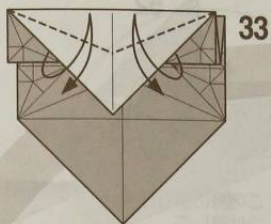

33

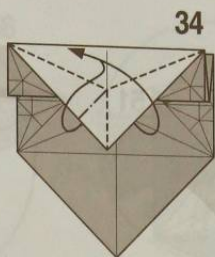

34

つけた
折り筋を
使って
折りたたむ

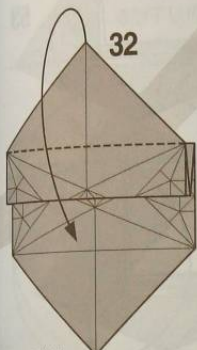

32

カドを
折り下げる

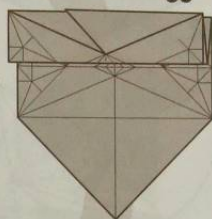

35

反対側も
31~34
と同じ



ついている
折り筋で
中わり折り

37

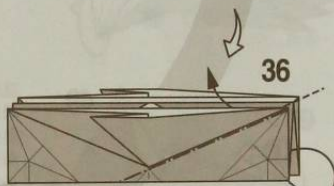

36

ついている
折り筋で
中わり折り

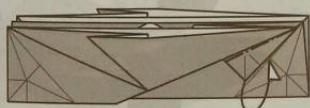

38

ついている
折り筋で
中わり折り



39

反対側も36~38と同じ



42

■の部分
を
平らにひらく
ようにする

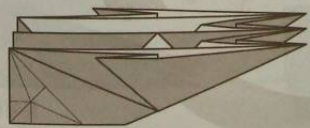

40

カドを反対側に
折る

41



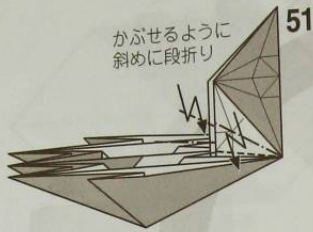

かぶせるように
斜めに段折り

51

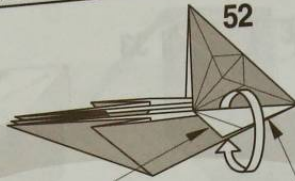

この縁の折り筋を
つけ直して
裏返すようにする
反対側も同じ

52

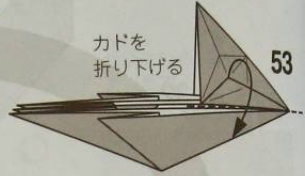

カドを
折り下げる

53

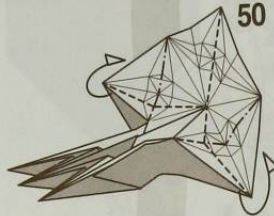

内側から見た図
山、谷に注意

50

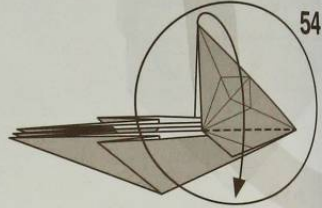

カドを
下に折る

54

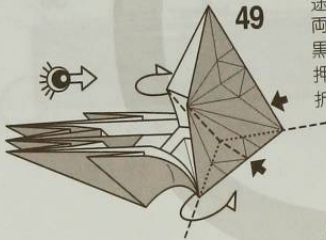

途中の図
両側とも
黒矢印の部分
を押すようにして
折りたたむ

49

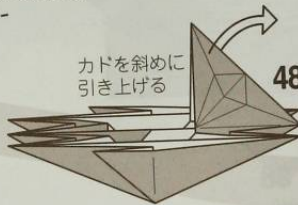

カドを斜めに
引き上げる

48

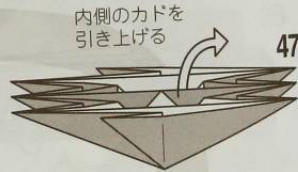

内側のカドを
引き上げる

47

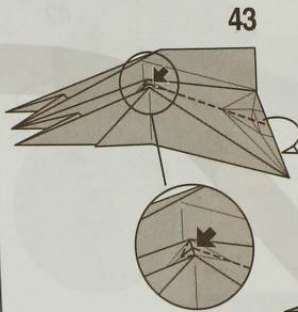

途中の図
ついている折り筋で
黒矢印の部分
押し込んで
カドにして
折りたたむ

43

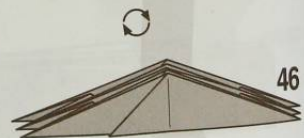

46

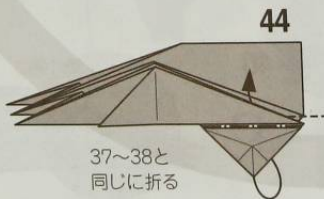

37~38と
同じに折る

44



反対側も
42~44と同じ

45

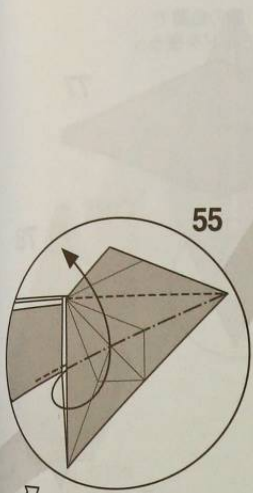

55

内側をひろげて
つぶすように
折る

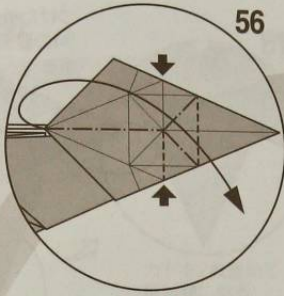

56

内側をひろげて
黒矢印の部分
押し込むようにして
つぶすように折る

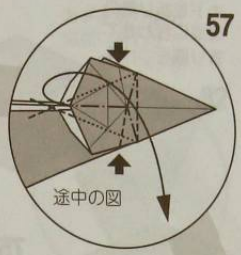

57

途中の図

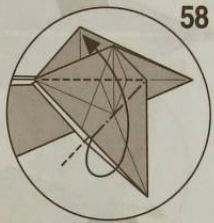

58

内側をひろげて
つぶすように折る

カドをまとめて
上に折る

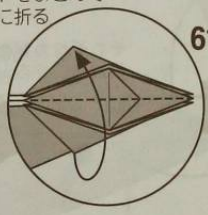

61

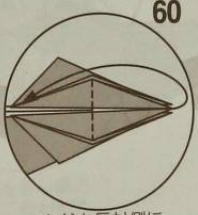

60

カドを反対側に
折る

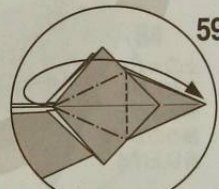

59

内側をひろげて
つぶすように折る

62

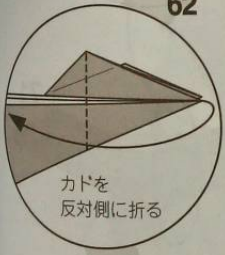

カドを
反対側に折る

63

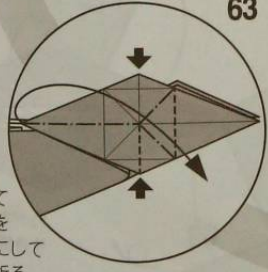

56~57と
同じ要領で
内側をひろげて
黒矢印の部分
押し込むようにして
つぶすように折る

58~59と同じ要領で
内側をひろげて
黒矢印の部分
押し込むようにして
つぶすように折る

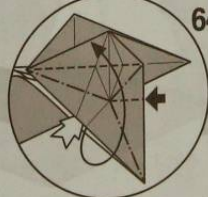

64

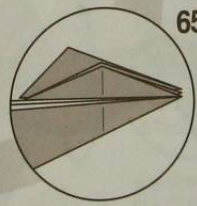

65

反対側も
62~64と
同じ

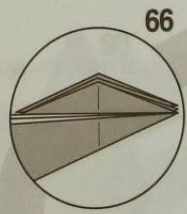

66

カドを折り筋の
交点に合わせて
折り筋をつける

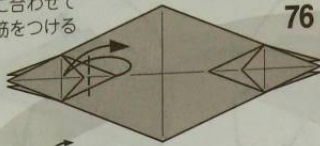

76

つけた折り筋の位置で
74の要領でカドを後ろへ
折る

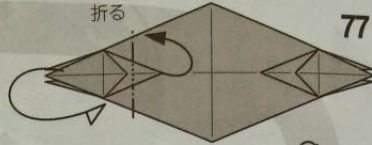

77

6

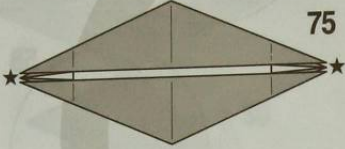

75

0

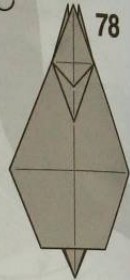

78

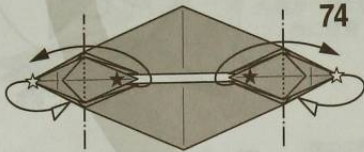

74

☆のカドを
後ろへ折るときに
★のカドを
持ち上げるように
反対側に折る

上のカドを
左右均等に
開きながら
後ろのカドを
折り上げる

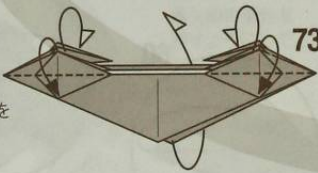

73

それぞれカドを
反対側に折る



72

反対側も47~66と
同じ



67

反対側も
68~70と同じ

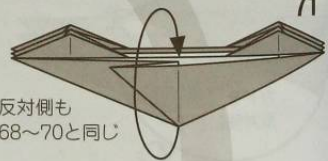

71

カドを
折り上げる

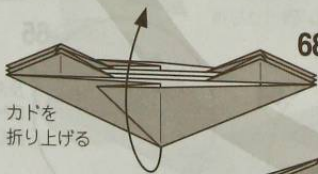

68

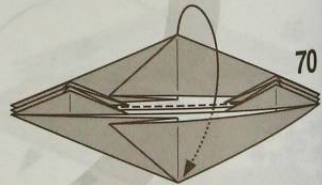

70

カドをすぐ下の
すき間に折り込む

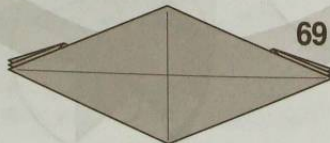

69

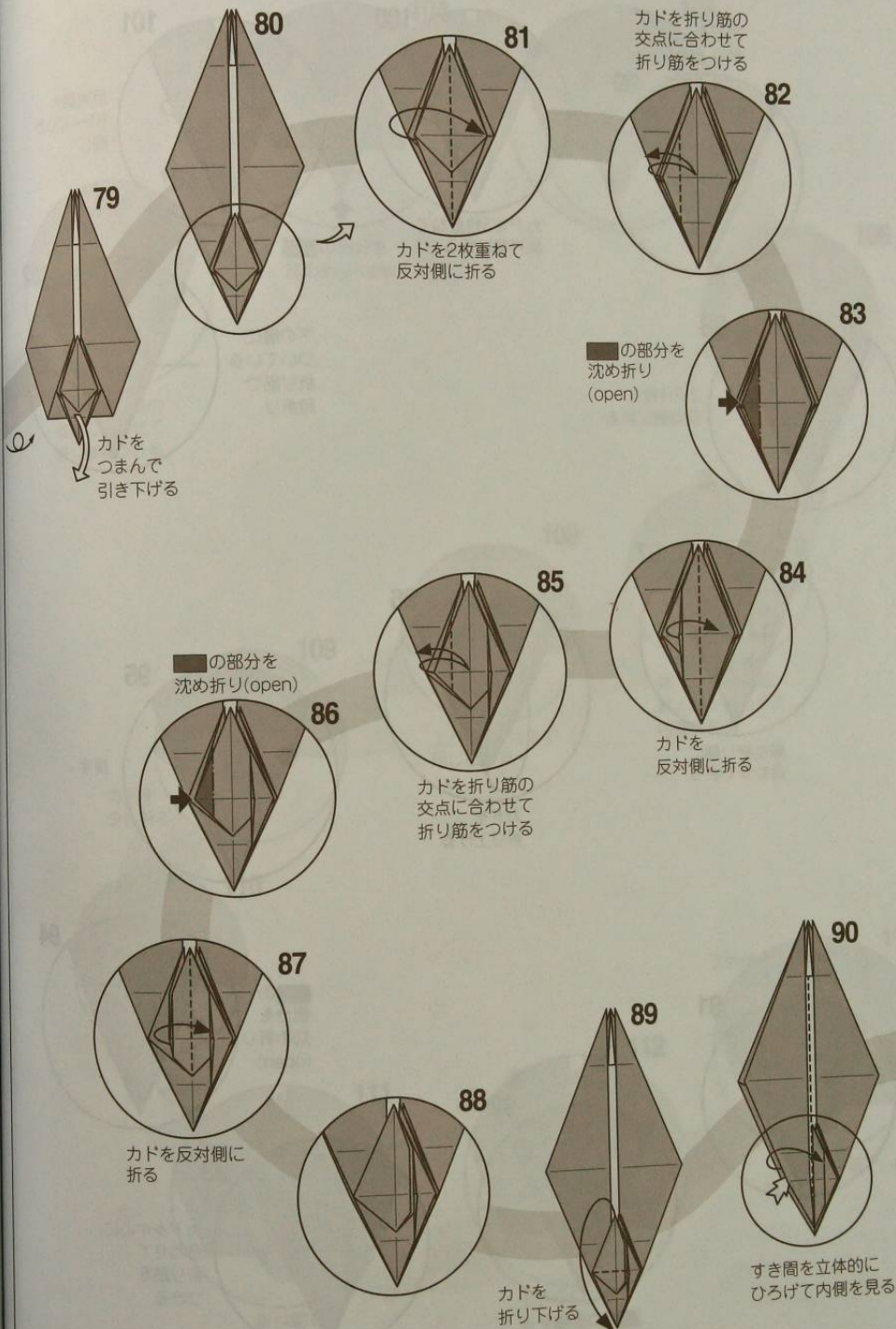

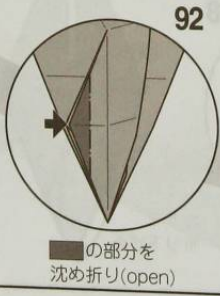
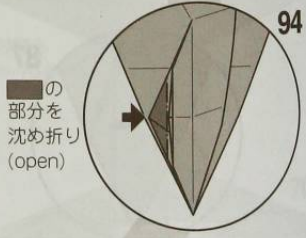
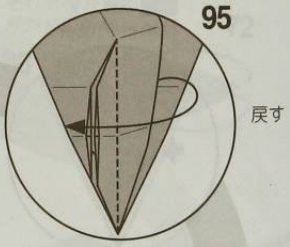
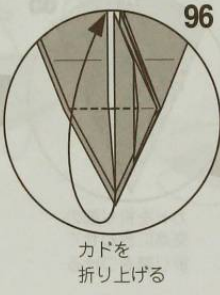
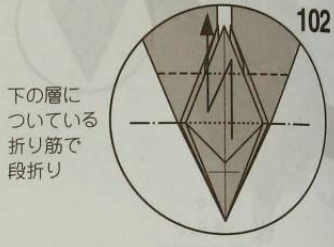
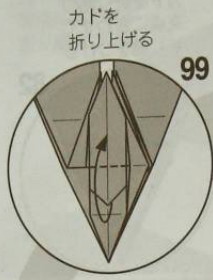

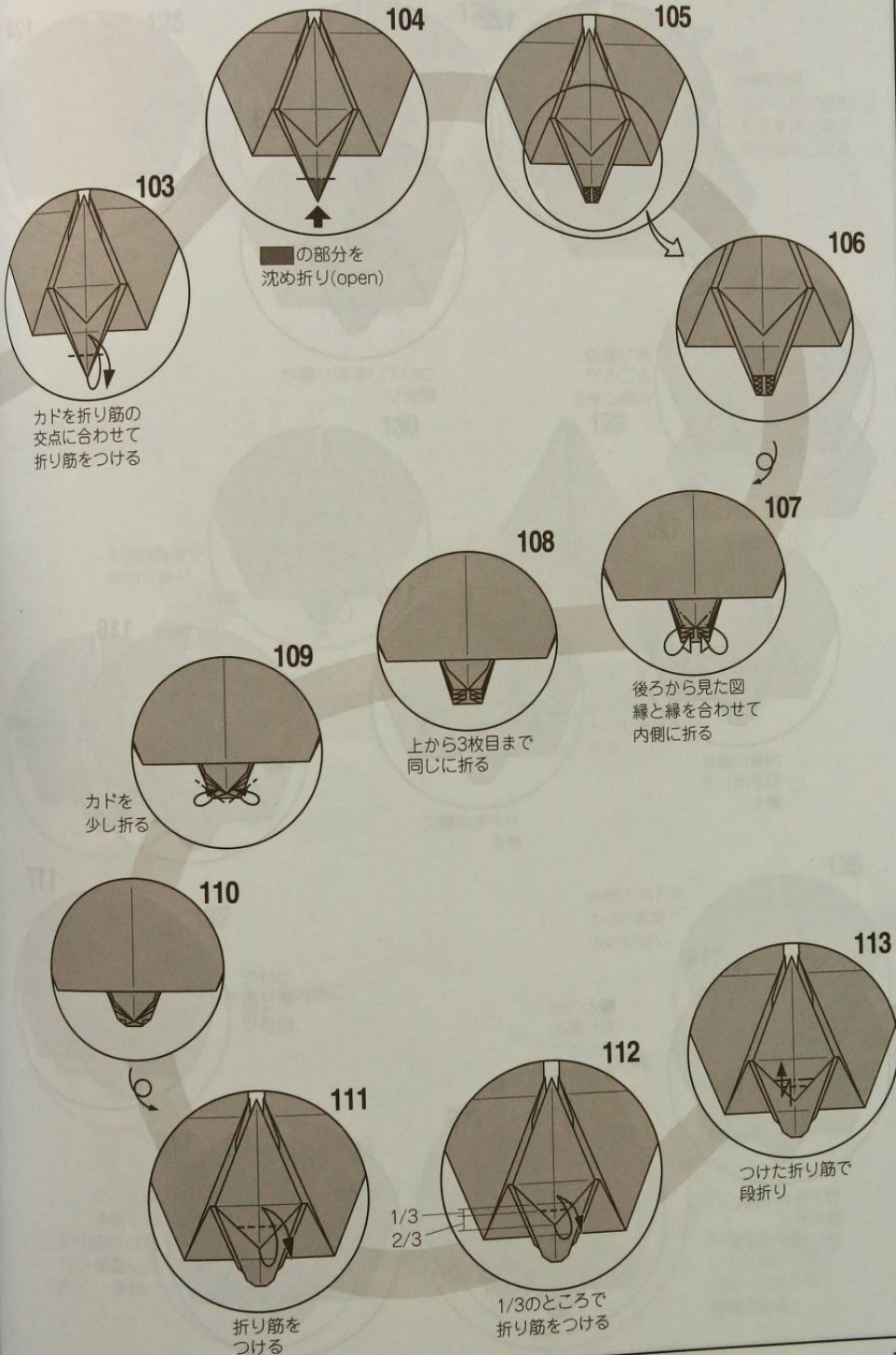

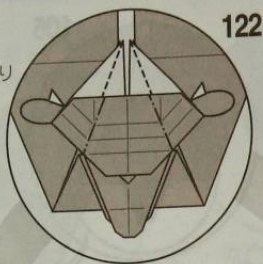

122

中わり折り

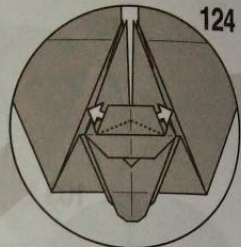

124

内側の紙を引き出す

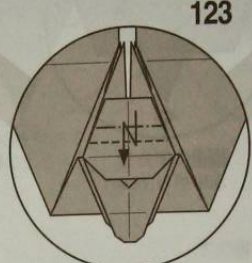

123

ついている折り筋で段折り

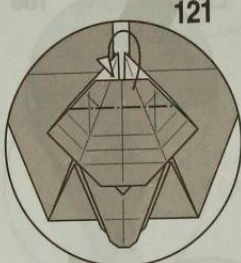

121

折り筋のところで内側に折る

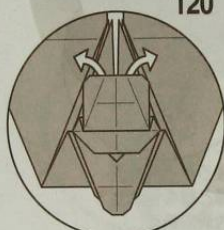

120

内側の紙を引き出して開く

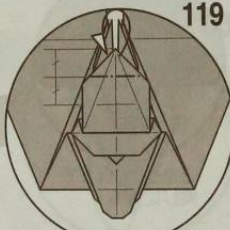

119

カドを内側に折る

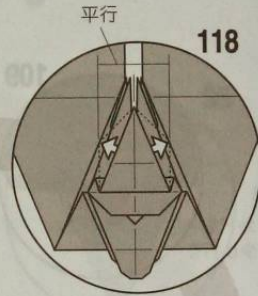

118

内側の紙を引き出す

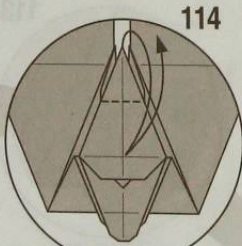

114

カドを折り筋に合わせて折り筋をつける

●と○の折り筋を合わせて折り筋をつける

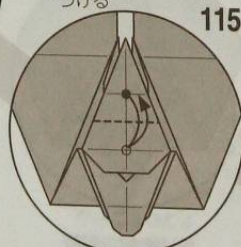

115

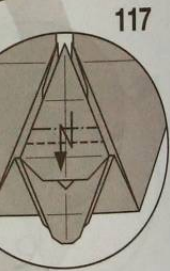

117

つけた折り筋で段折り

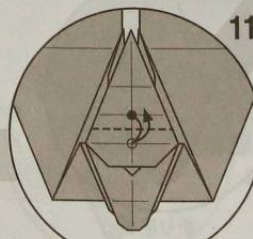

116

●と○の折り筋を合わせて折り筋をつける

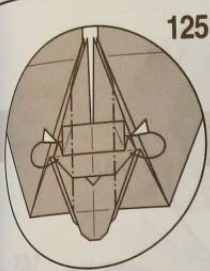

125
カドを2枚
かさねた状態
で
すき間に折る

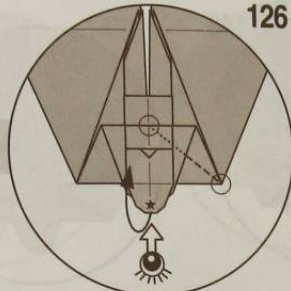

126
かるく開いて
内側を見る



127
内側の図
カドと折り筋の
交点を結ぶ線
で
折り筋をつける

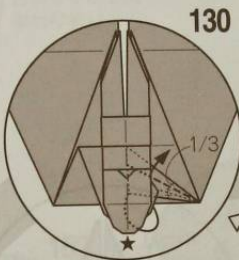

130
1/3の角度で
中わり折り

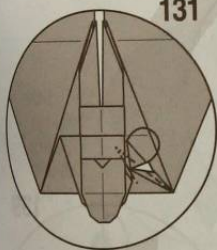

131
下の縁に沿って
カドを
内側に折る

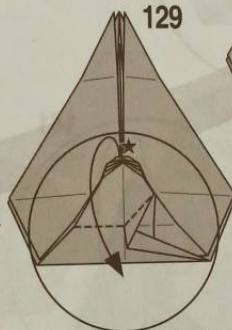

129
縁を中心に合わせ
たまま
つぶすように折る

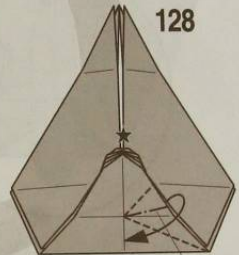

128
この縁に
なる線を
中心に
合わせて
折る

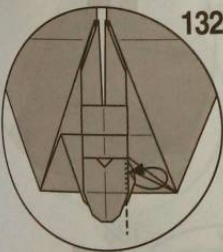

132
カドを内側に
折る

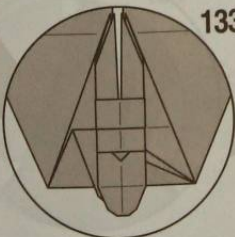

133
反対側も
126~132と
同じ

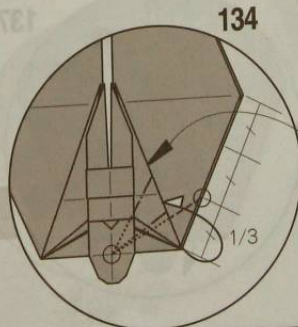

134
1/3

134
内側のカドを
こちら側から見て
126~129と同じ
要領で折る

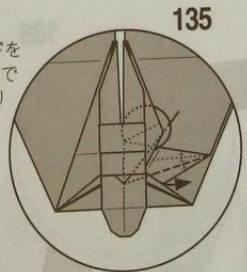

135
内側のカドを
1/3の角度で
中わり折り

99で
折り上げた
内側のカドを
中わり折り

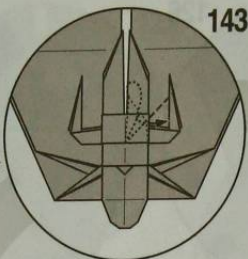

143

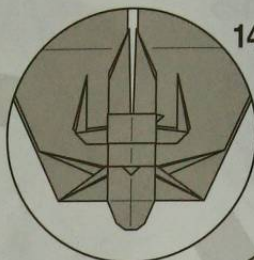

144

反対側も
同じ

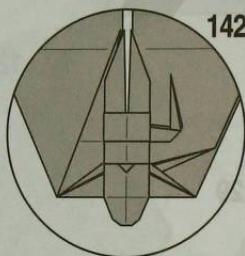

142

反対側も
134~141と
同じ

縁を○のところに
合わせるように
中わり折り

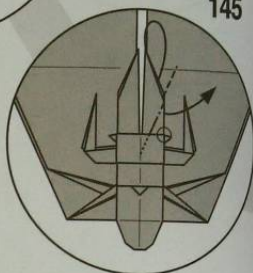

145

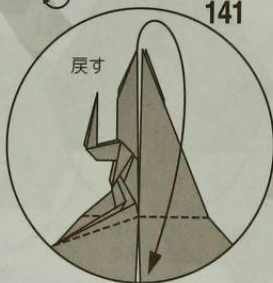

141

戻す

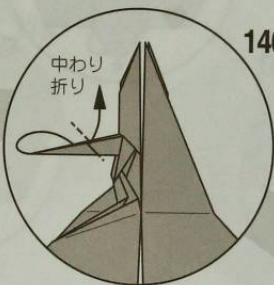

140

中わり
折り

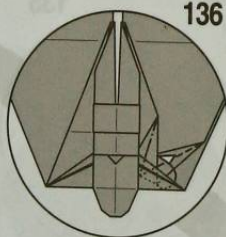

136

下の縁に
沿って
カドを
内側に折る

軽く開いて
内側を立体的に
見る

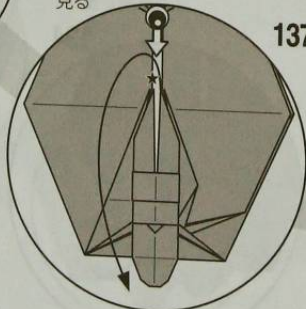

137

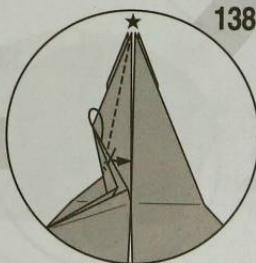

138

縁と縁を
合わせて
中わり折り

反対側も
145~146と
同じ

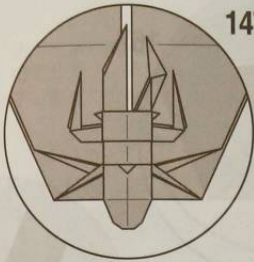

147

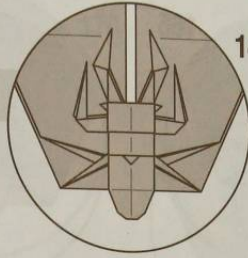

148

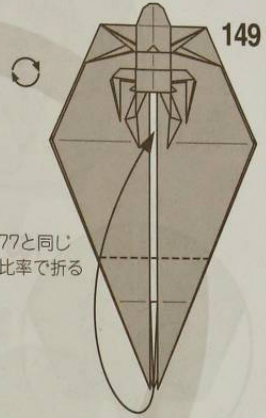

149

77と同じ
比率で折る

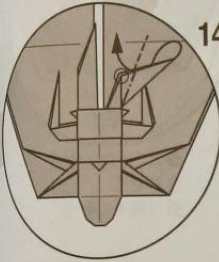

146

線を○のところに
合わせるように
中わり折り



152

●と○の
折り筋を
合わせて
折り筋を
つける



151

折り筋をつける

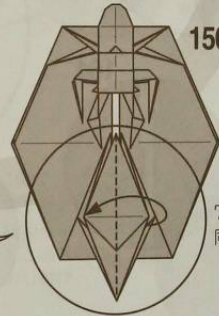

150

77~100と
同じに折る

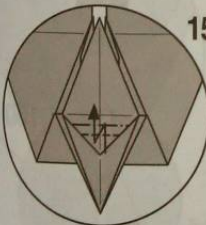

153

つけた
折り筋で
段折り

カドを折り筋に
合わせて
折り筋をつける

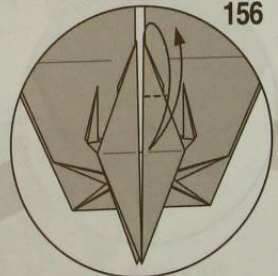

156

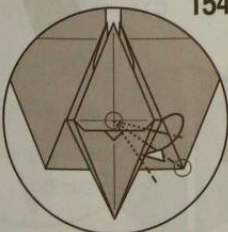

154

126~142と
同じに折って
足をつくる

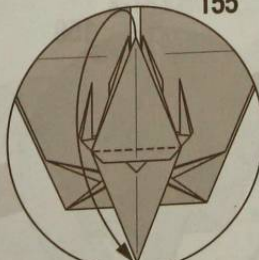

155

一番上のカドを
下に折る

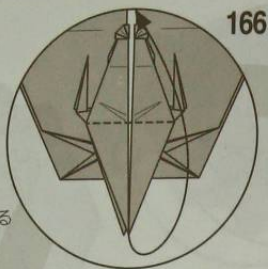

カドを
折り上げる

166

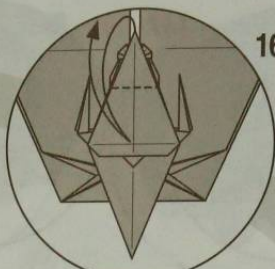

カドを
折り筋に合わせて
折り筋をつける

167



●と○の折り筋を
合わせて
折り筋をつける

168

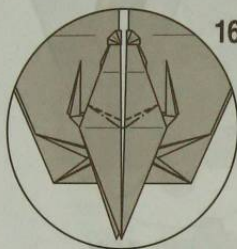

図のような
折り筋を
つける

165

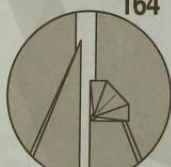

反対側も同じ

164

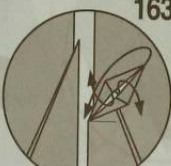

内側をひろげて
つがすように折る

163

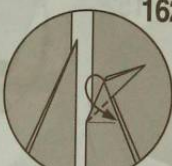

カドを
斜めに折る

162



中わり
折り

161

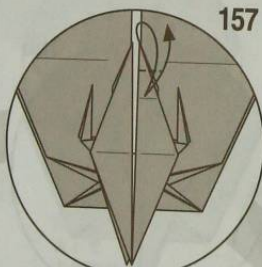

カドを折り筋に
合わせて
折り筋をつける

157

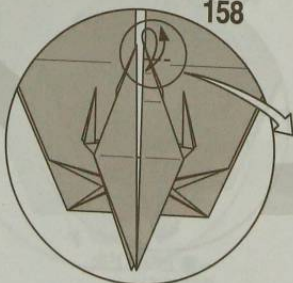

カドを折り筋に
合わせて
折り筋をつける

158

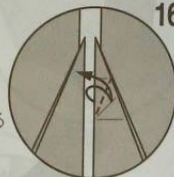

縁を折り筋に
合わせて
折り筋をつける

160



縁を折り筋に
合わせて
折り筋をつける

159

カドを折り筋に合わせて
合わせて
折り筋をつける

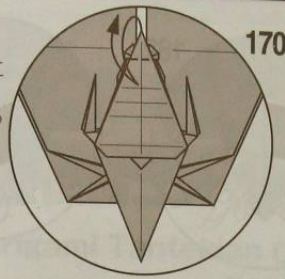

170

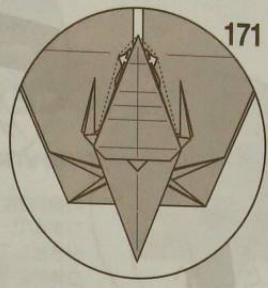

171

内側の紙を
引き出す

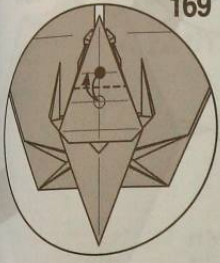

169

●と○の折り筋を
合わせて
折り筋をつける

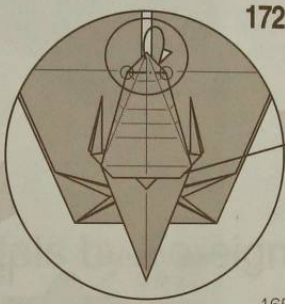

172

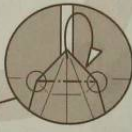

○と○を
結ぶ線で
カドを
後ろへ折る

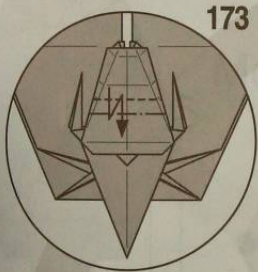

173

ついている
折り筋で
内側に段折り

165でつけた
折り筋を使って
ひねるようにして
面と面を合わせて
のり付け

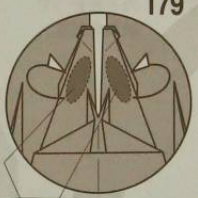

179

■の裏側に
のりを付ける

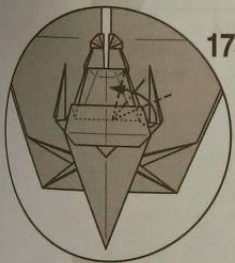

174

裏の縁に沿って
中わり折り

カドと
カドを
合わせて
折る

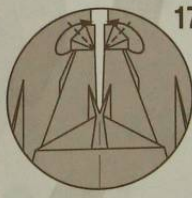

178

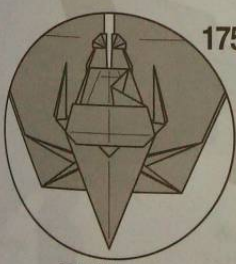

175

反対側も同じ

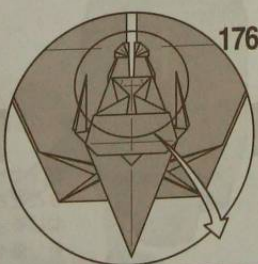

176

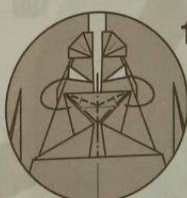

177

カドをつまむように
して図のような
折り筋で折りたたむ

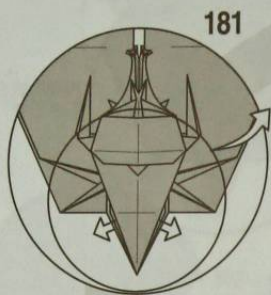

181

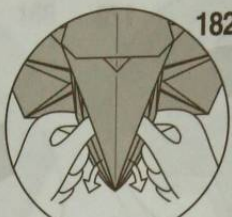

182

途中の図
内側の2枚をつまんで
引き出して
立体的にする

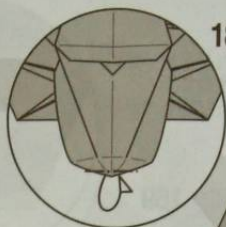

183

カドを
内側に折る

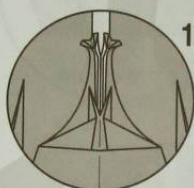

180

ここで143のように
カドを折って
触角をだす

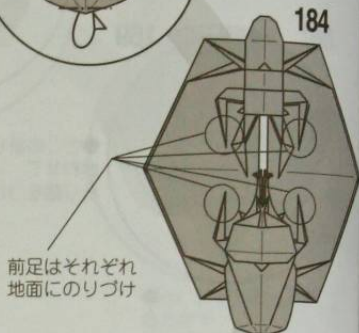

184

前足はそれぞれ
地面にのりづけ

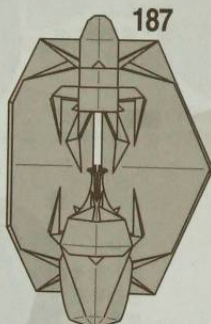

187

反対側も
185~186と
同じ

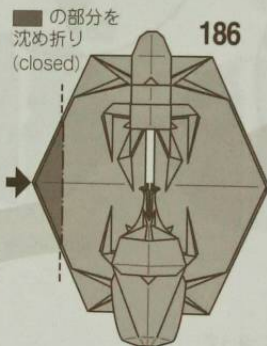

186

■の部分
沈め折り
(closed)

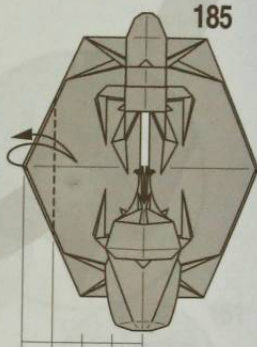

185

1/4

1/4のところで
折り筋をつける

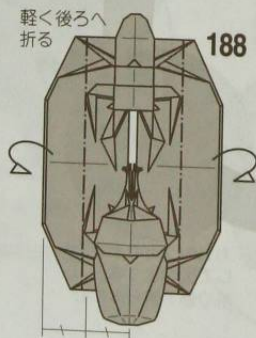

188

軽く後ろへ
折る

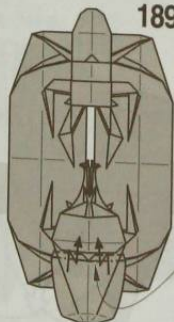

189

ピンセット
などをさし込み
ねじるようにして
折り筋をつける

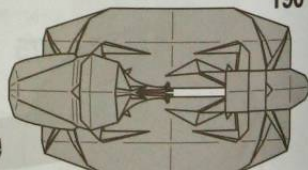

190

できあがり

第12回

折紙探偵団コンベンション折り図集

12th Origami Tanteidan Convention Book



©Robert J. Lang

海外編 / Models by Foreign Folders

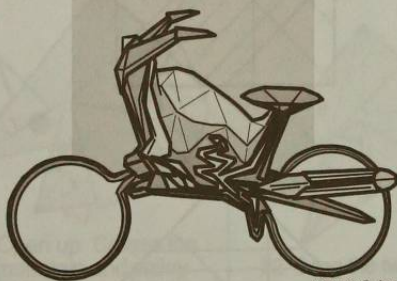

©Xander D. Arena

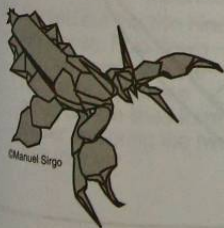

©Maruel Sirgo



©Nicolas Terry



©Marc Kirschenbaum

LION

© Cheng Chit Leong - 2005

(Singapore)

Complex

A 60 cm. square gives a model of 25 cm. from nose to tail.

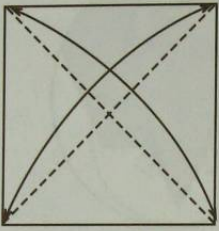

1. Coloured side facing down, crease.

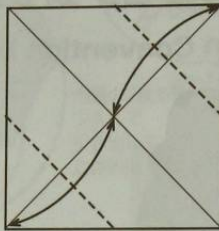

2. Crease.

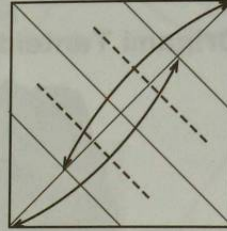

3

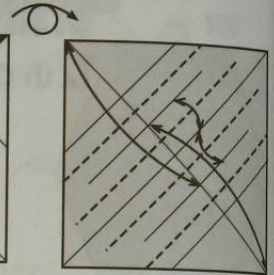

4. Crease.

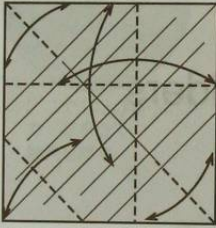

5. Crease. Turn over.

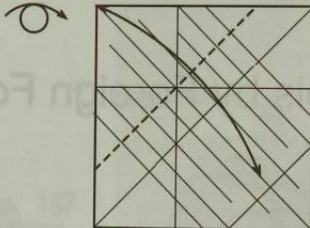

6

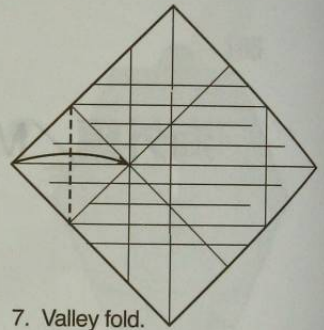

7. Valley fold.

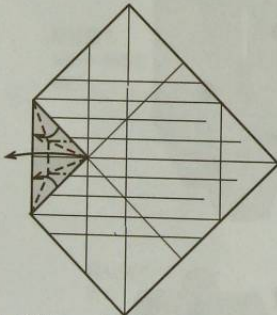

8. Collapse for the tail piece.

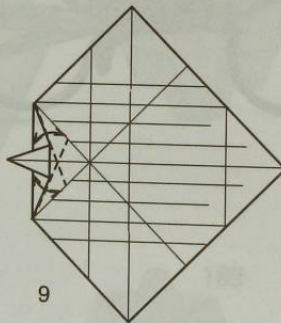

9

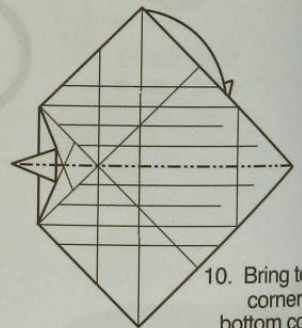

10. Bring top corner to bottom corner.

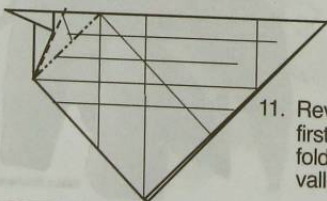

11. Reverse fold twice, first along mountain fold and then along valley.

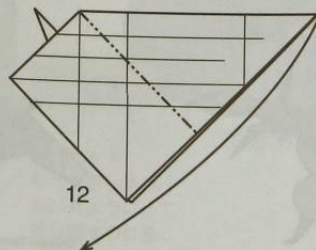

12

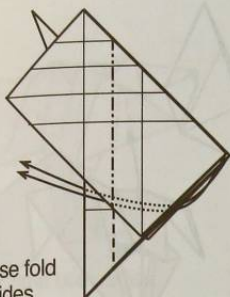

13. Reverse fold both sides. Turn 90 degrees anti-clockwise.

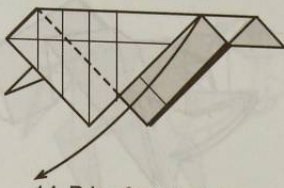

14. Bring front flap down.

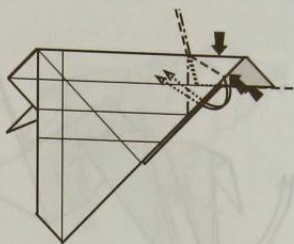

15. Open up and collapse symmetrically both sides ...

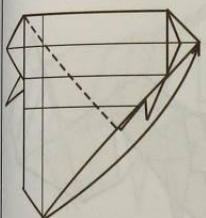

16. ... like this. Bring flap up to earlier position.

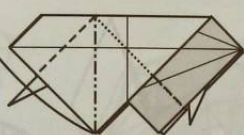

17. Swivel. Repeat for other side.

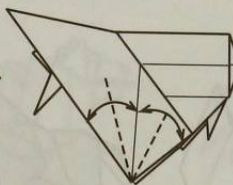

18. Crease both sides. Flip over vertically.

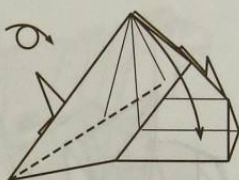

19. Bring down flap. Do not crease all the way.

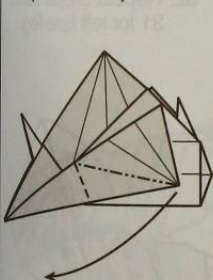

20. Bring flap down to left. Crease only the valley and mountain folds.

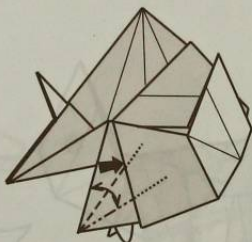

21. Open up. Crease the mountain and valley folds but do not flatten.

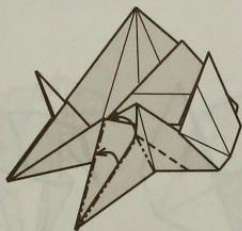

22. Bring the two mountain folds together and collapse.

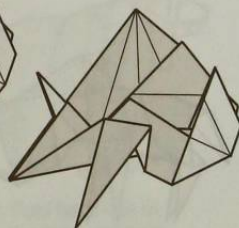

23. Repeat for the other side.

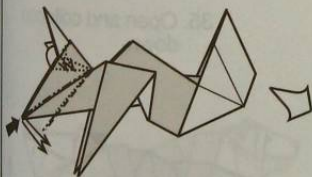

24. Spread out the two hind leg pieces. Fold down the two corners of the hidden half squares along crease lines from earlier and bring the two legs forward.

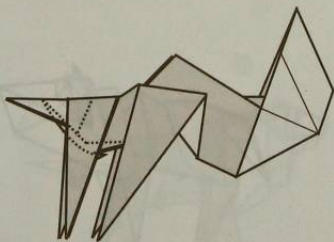

25. Reverse fold the hidden tip. (It's a boy!)

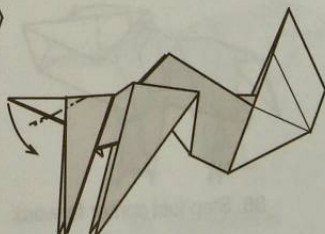

26. Reverse fold.

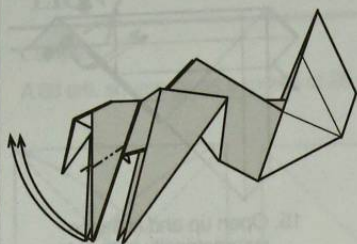

27. Reverse fold the two hind legs.

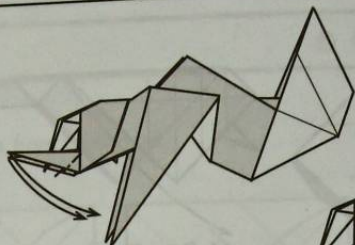

28. Reverse fold again.

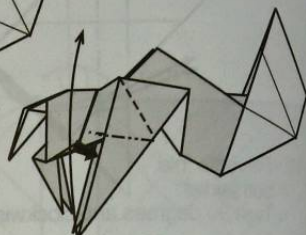

29. Open and bring tip up.



30. Bring tip down.

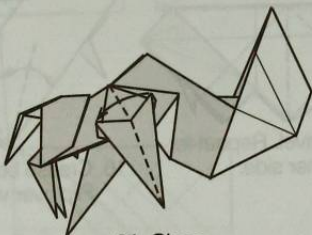

31. Close.

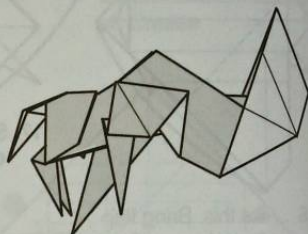

32. Repeat Steps 29 to 31 for left fore leg.

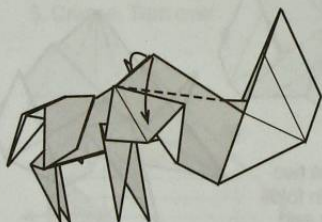

33. Fold down the two flaps.

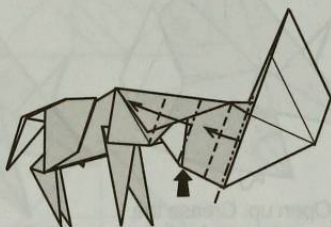

34. Spread out and step fold.

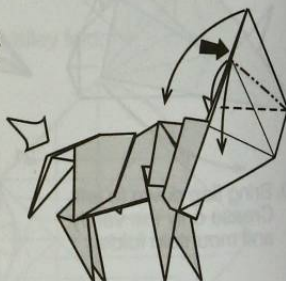

35. Open and collapse down.

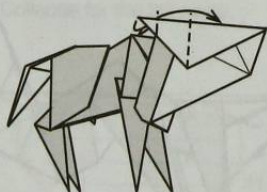

36. Step fold corner forward.



37. Bring up the tips on both sides for the ears.



38. Fold back tip for the nose.



39. Crimp both sides.

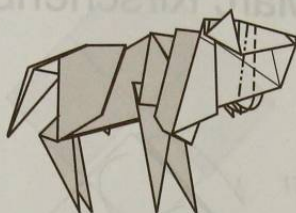

40. Crimp both sides.



41. Fold in tip of nose.

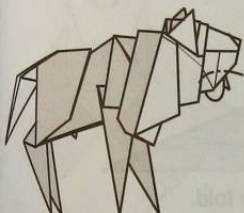

42. Shape lower jaw.



43. Crimp to form mouth and indent for the eyes.



44. Swivel to form ears and tuck in to lock mane on both sides.

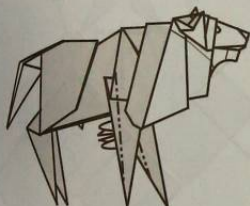

45. Narrow the fore legs by folding edges in.

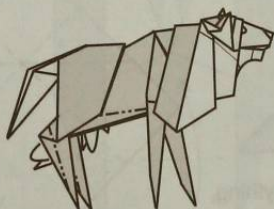

46. Tuck in tummy on both sides and narrow the hind legs by folding edges in.

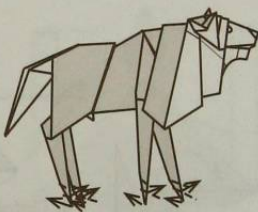

47. Fold back tips of the legs and form the feet.

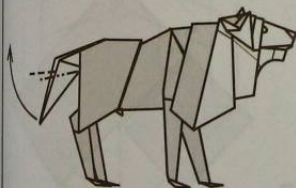

48. Reverse fold.



49. Narrow the tail and shape the body.

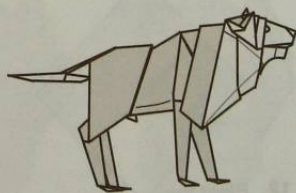

50. The model is completed.

Elephant by Marc Kirschenbaum

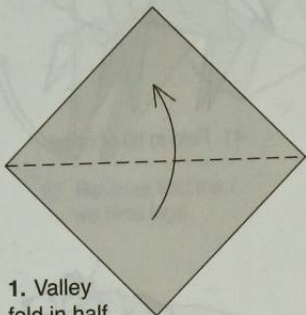

1. Valley fold in half.

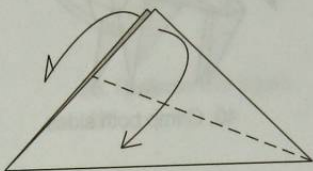

2. Valley fold the sides down along angle bisectors.

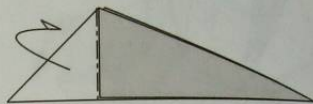

3. Mountain fold.



4. Precrease along the angle bisector.



5. Valley fold the left edge towards the crease, allowing the back flap to flip out.



6. Valley fold.

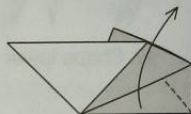

7. Valley fold the flap up.



8. Mountain fold.

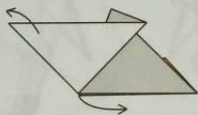

9. Unfold everything, opening up to the white side.

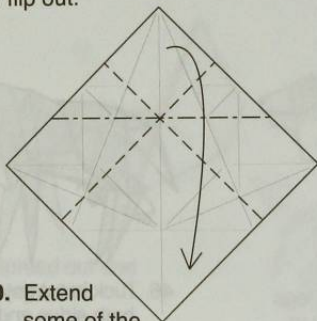

10. Extend some of the creases, and collapse down.

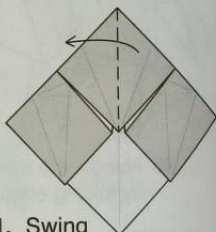

11. Swing over the top flap.

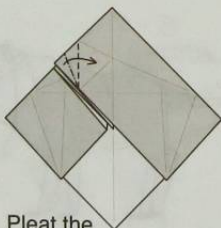

12. Pleat the corner, starting with the existing valley fold crease.

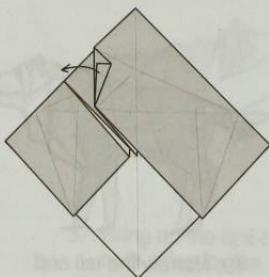

13. Unfold the pleat.

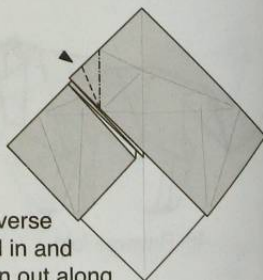

14. Reverse fold in and then out along the existing creases.

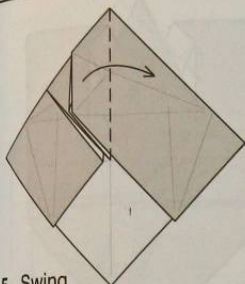

15. Swing the flap back over.

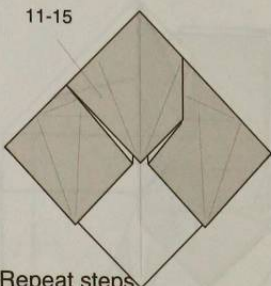

16. Repeat steps 11-15 in mirror image.

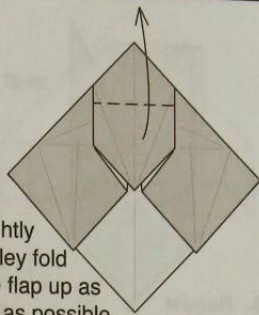

17. Lightly valley fold the flap up as far as possible.

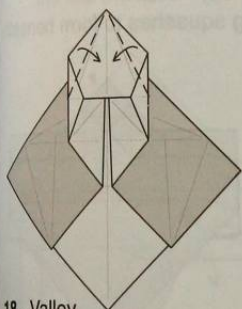

18. Valley fold the sides inwards.

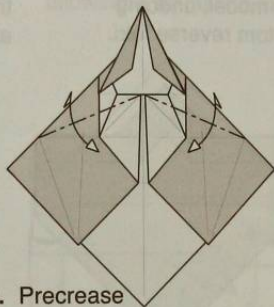

19. Precrease with mountain folds (extending the existing creases).

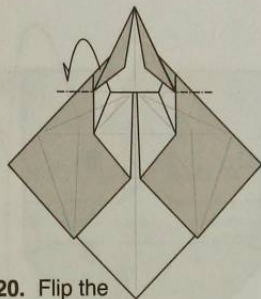

20. Flip the back flap down.

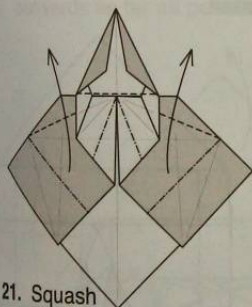

21. Squash the sides upwards.

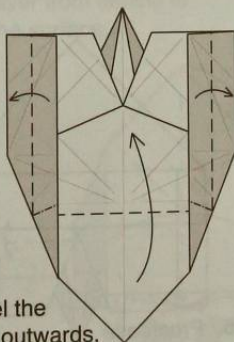

22. Swivel the sides outwards, allowing the bottom to fold up.

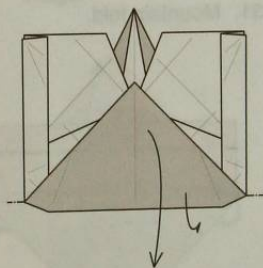

23. Flip the bottom flap.

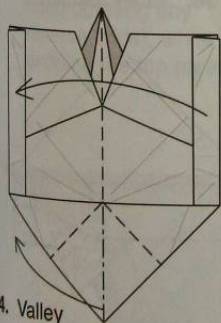

24. Valley fold in half while reverse folding at the bottom.

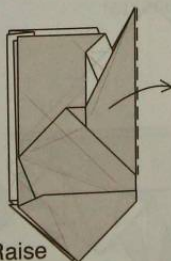

25. Raise the top layer. The model will not lie flat.

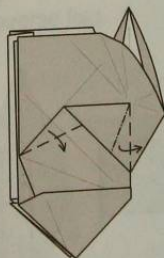

26. Swivel over.

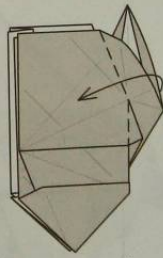

27. Bring the flap back down.

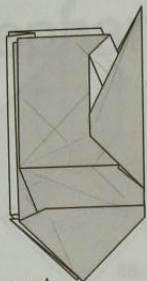

25-27

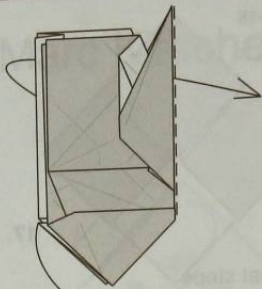

28. Repeat steps 25-27 behind.

29. Open out the model, undoing the bottom reverse fold.

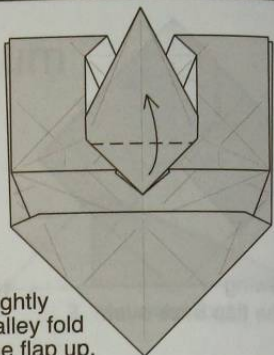

30. Lightly valley fold the flap up, allowing squashes to form beneath.

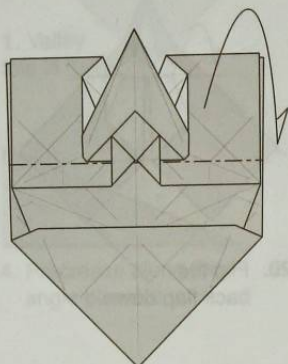

31. Mountain fold.

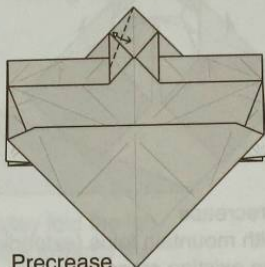

32. Precrease along the angle bisector.

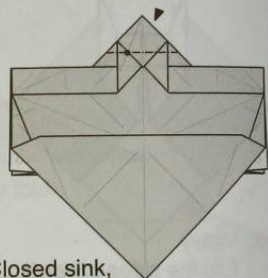

33. Closed sink, noting the indicated reference point.

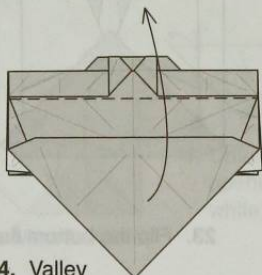

34. Valley fold the flap up.

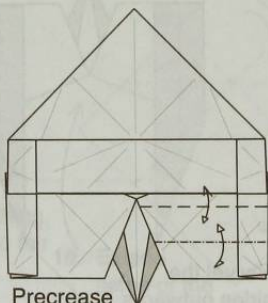

35. Precrease the indicated section into thirds.

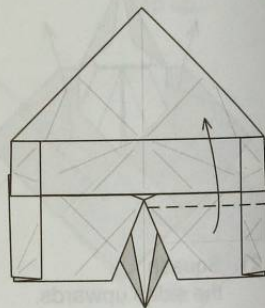

36. Valley fold up.

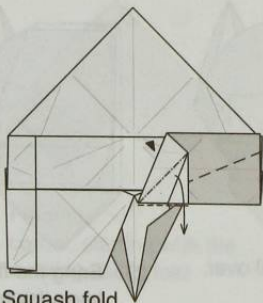

37. Squash fold.

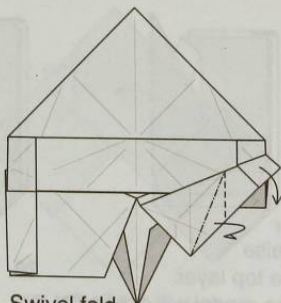

38. Swivel fold.

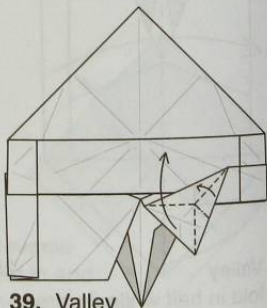

39. Valley fold up while swiveling in.

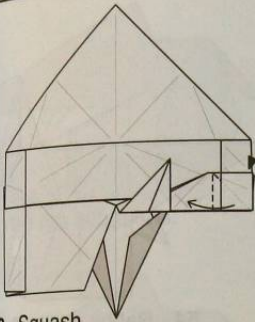

40. Squash the flap inwards.

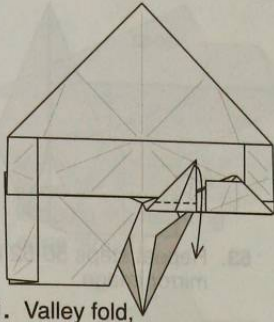

41. Valley fold, allowing a squash to form.

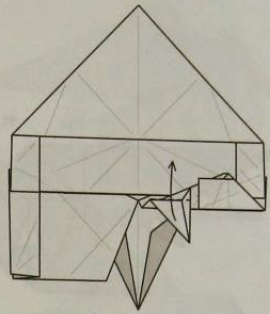

42. Swing back up.

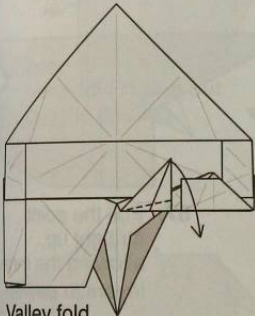

43. Valley fold outwards as far as possible.

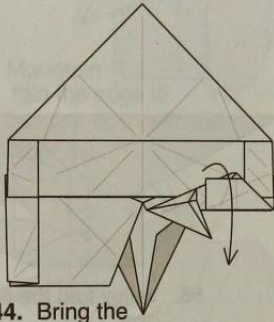

44. Bring the layer from behind to the surface.

35-44

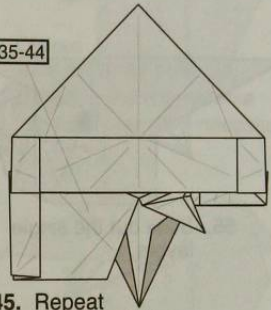

45. Repeat steps 35-44 in mirror image.

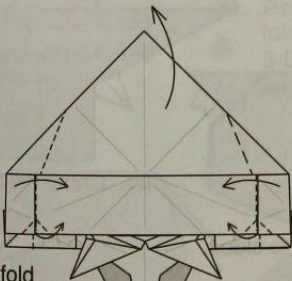

46. Valley fold the sides inwards (incorporating tiny reverse folds), while undoing the top pleat.

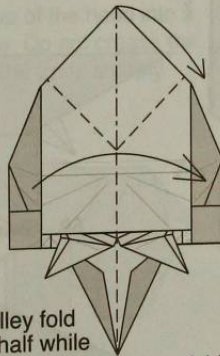

47. Valley fold in half while replacing the reverse fold.

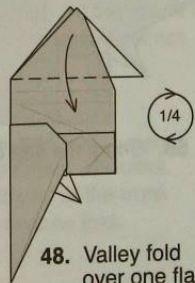

48. Valley fold over one flap. Rotate the model.

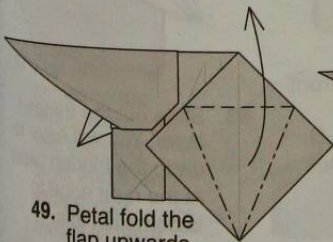

49. Petal fold the flap upwards.

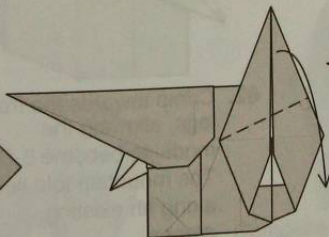

50. Valley fold.

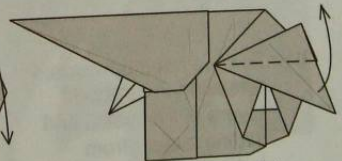

51. Valley fold up.

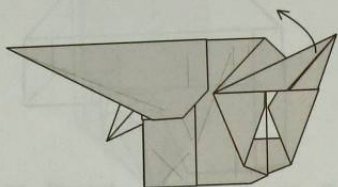

52. Unfold the pleat.

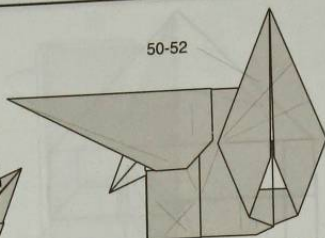

53. Repeat steps 50-52 in mirror image.

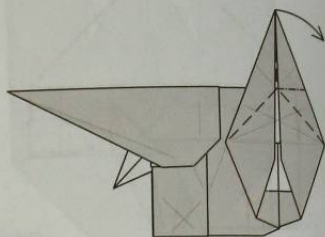

54. Rabbit ear the flap.

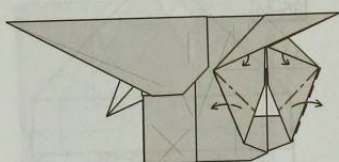

55. Slide out the single layers.

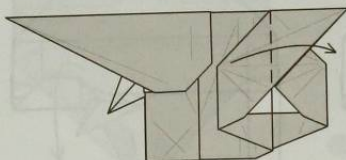

56. Valley fold the flap over.

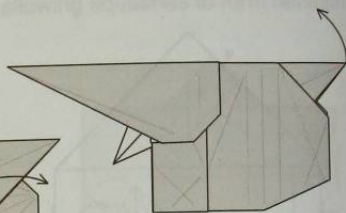

57. Pull the point straight up, allowing the inner layers to swivel.

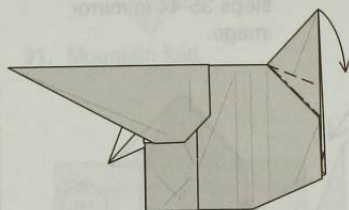

58. Crimp the flap down.

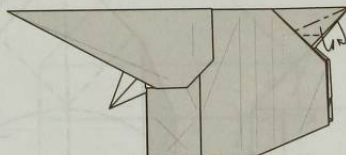

59. Swivel in the sides.

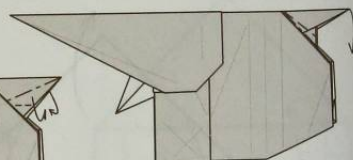

60. Crimp the flap down.

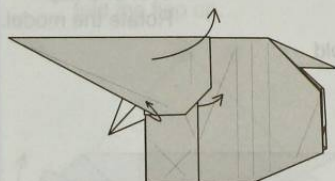

61. Pull the head upwards, releasing the trapped layers at the tusks, and sliding a layer from behind the legs.

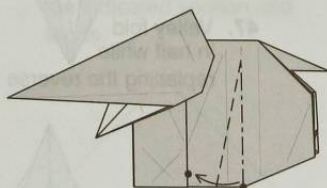

62. Crimp towards the front legs, allowing the model to become 3-D. The mountain fold lies along an existing crease.

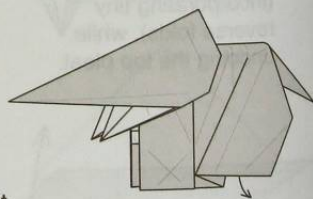

63. Slide out the trapped layer. You will have to undo the hidden pleat at the right edge to accomplish this.

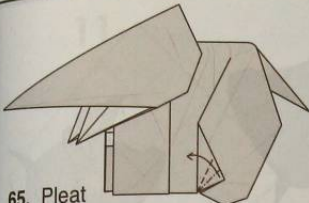

65. Pleat the flap into thirds.

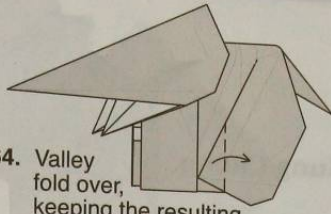

64. Valley fold over, keeping the resulting edge straight.

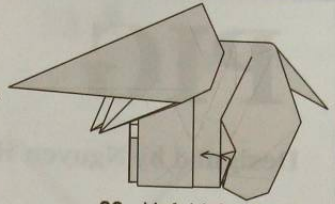

66. Unfold the pleat.

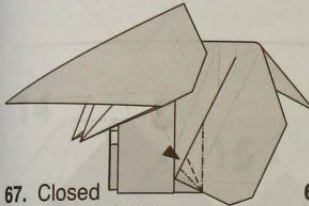

67. Closed reverse fold in and out along the existing

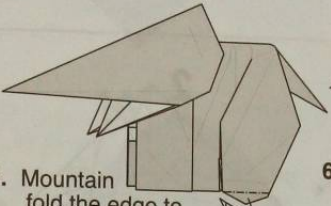

68. Mountain fold the edge to make it flush with the other leg.

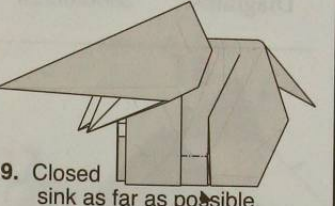

69. Closed reverse fold as far as possible, adjusting the tiny reverse fold from step 46 if necessary.

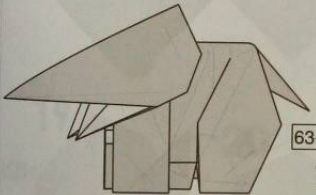

70. Repeat steps 63-69 behind.

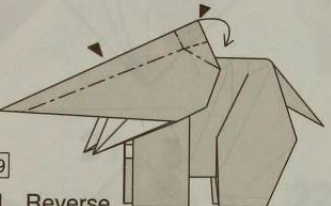

71. Reverse fold the top of the head into a 3-D shape. Do not create the length of the trunk sharply.

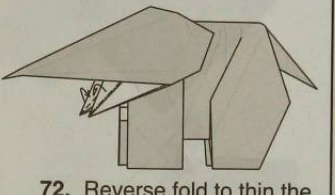

72. Reverse fold to thin the tusks. The tusks will be flat, but the inside of the model will not.

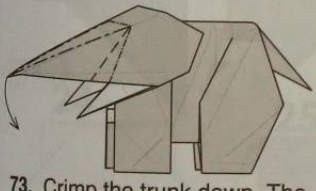

73. Crimp the trunk down. The long mountain folds that run the length of the trunk should be along angle trisectors.

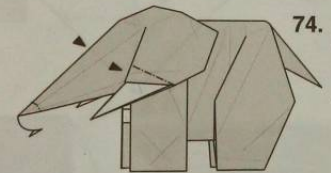

74. Add reverse folds where the ears meet the tusks. Blunt the tip of the trunk with a reverse fold.

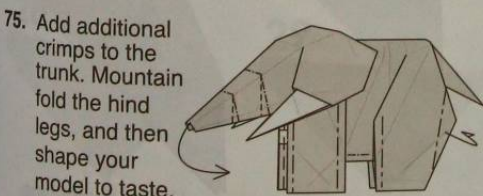

75. Add additional crimps to the trunk. Mountain fold the hind legs, and then shape your model to taste.



76. Completed Elephant
© 2004 Marc Kirschenbaum

PIG

Designed by Nguyen Hung Cuong

Model: 1999/xx/xx

Diagrams: 2006/06/24

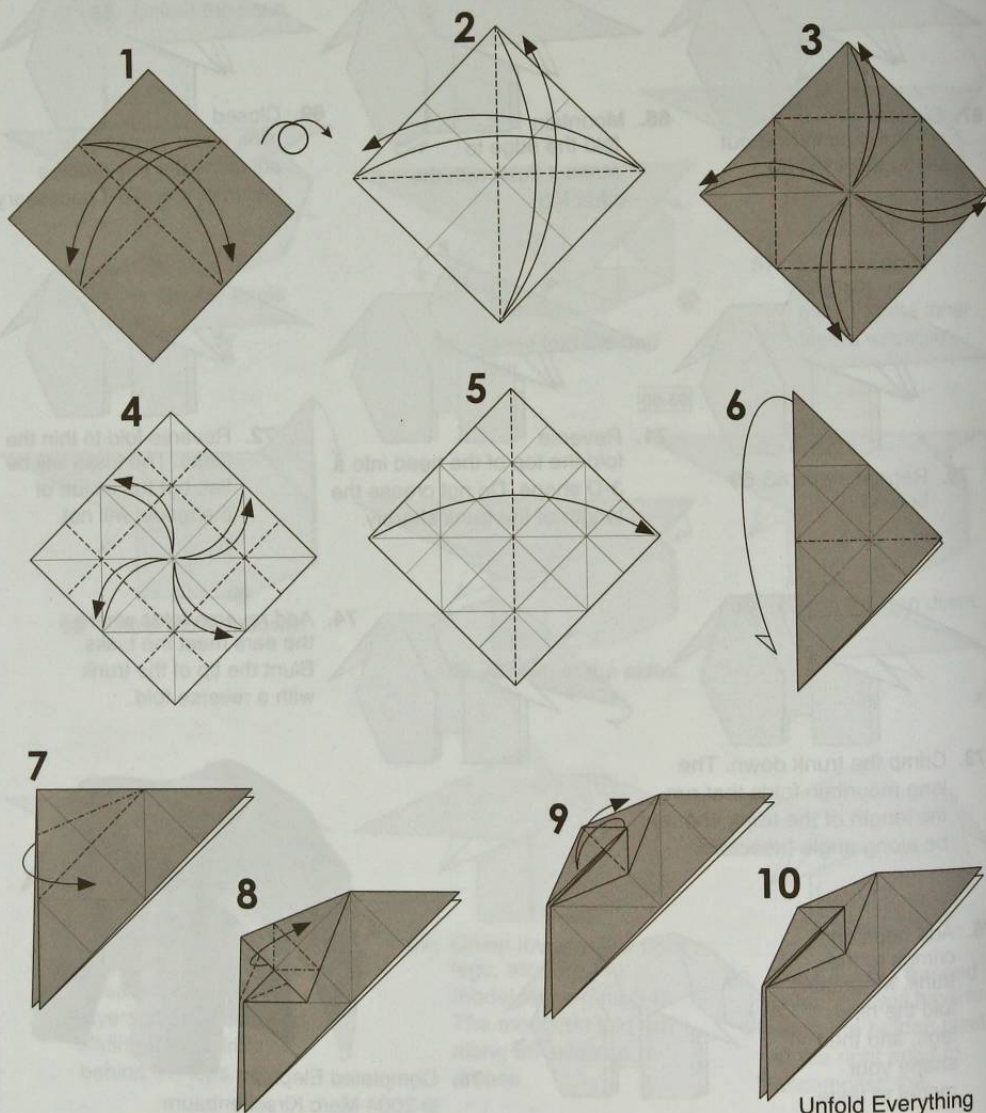
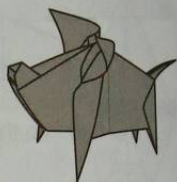
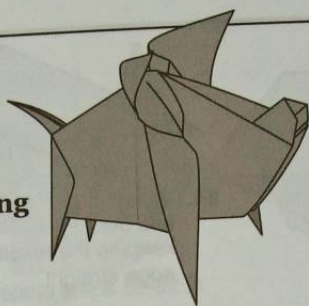

Unfold Everything

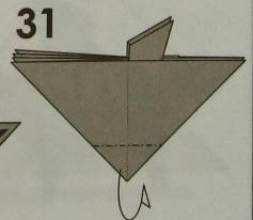
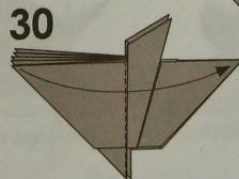
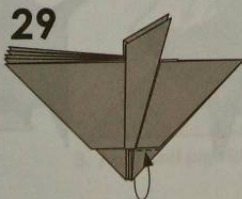
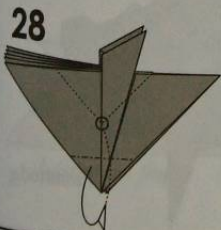
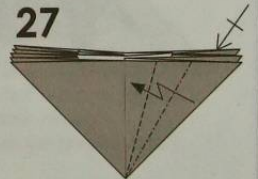
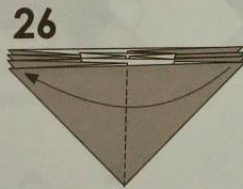
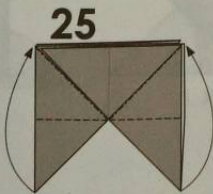
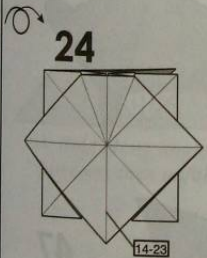
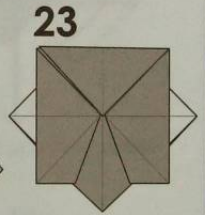
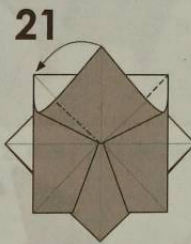
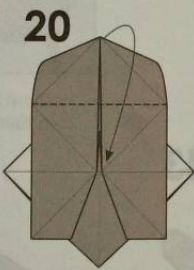
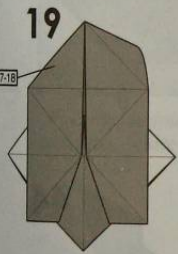
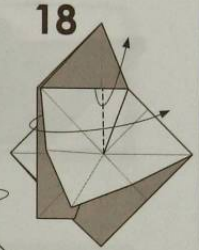
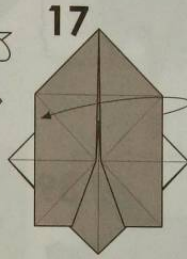
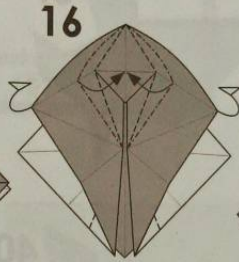
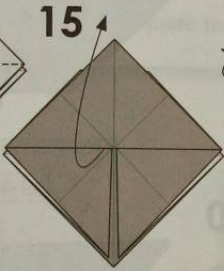
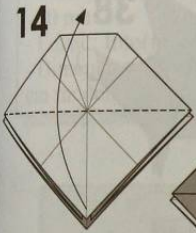
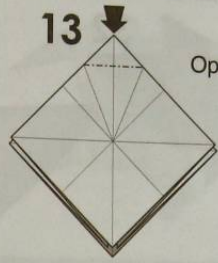
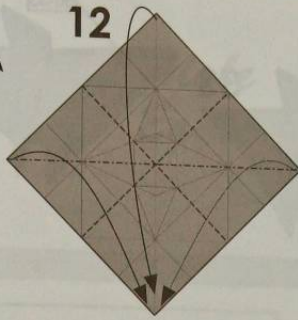
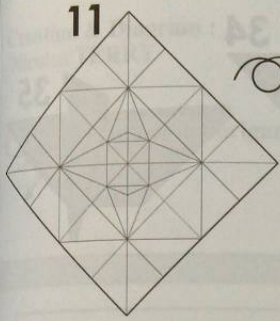

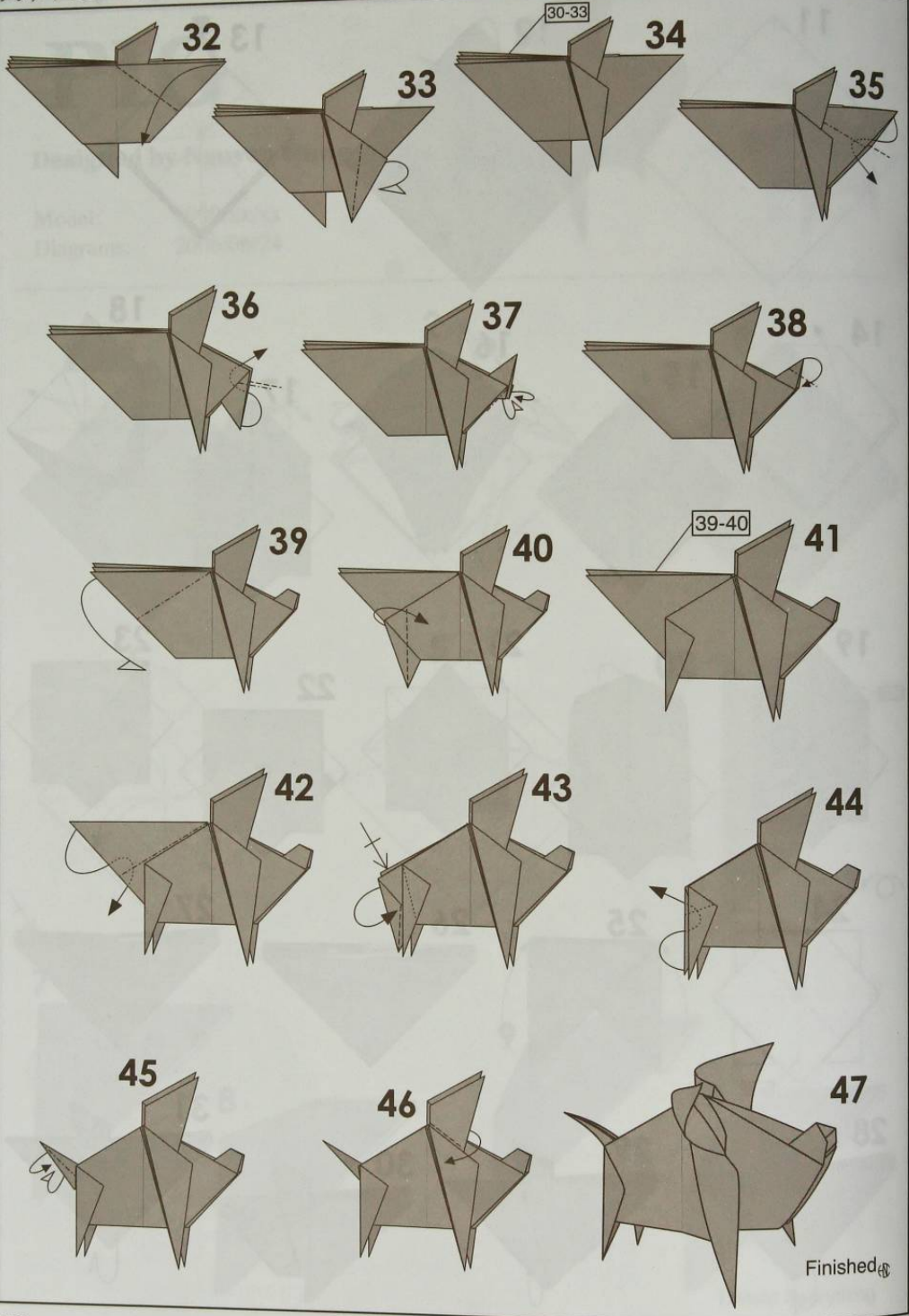

Creation & Diagram :
Nicolas TERRY

<http://www.passionorigami.com>

Aigle Eagle

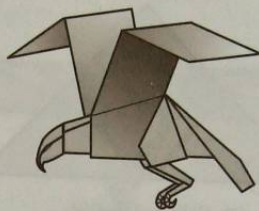

- Modèle # 82 - Dec 2005
- 30 mn
- Level : Intermediate
- Dimension : A 15 x 15 cm square makes a 6.5 x 12.5 cm model.

Paper :
 Standard paper
 Tissue-foil
 Wet folding

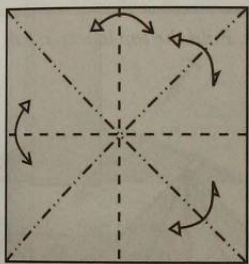

1. Fold and unfold a water bomb base, white side out.

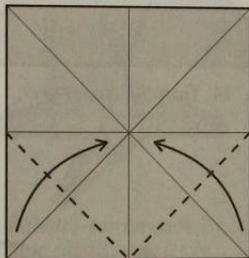

2. Valley-fold the corners.

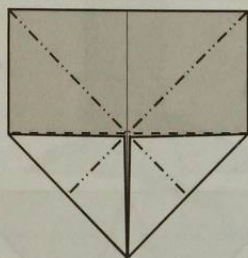

3. Re-fold as a water-bomb base.

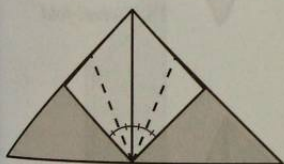

4. Fold along angle bisectors then unfold.

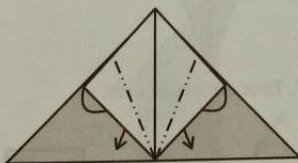

5. Reverse-folds.

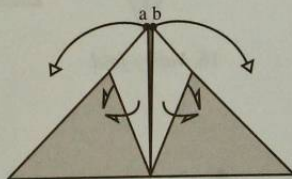

6. Pull out each flap to colour-change (Outside reverse-folds).

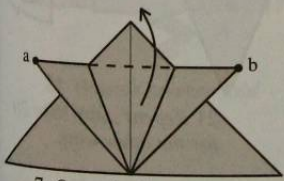

7. Open the flap.

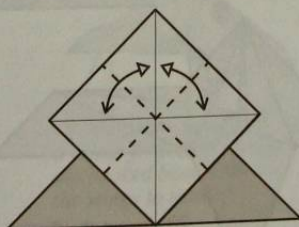

8. Fold and unfold the top layer.

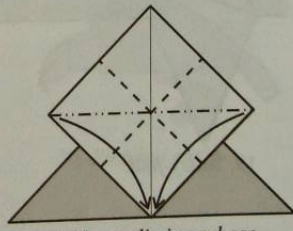

9. Fold a preliminary base.

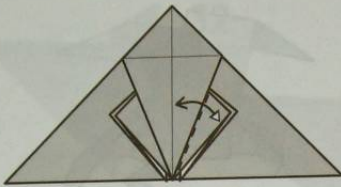

10. Fold and unfold.

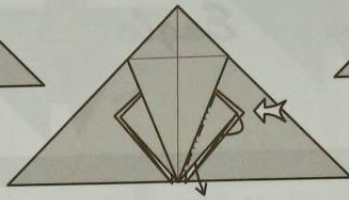

11. Reverse-fold.

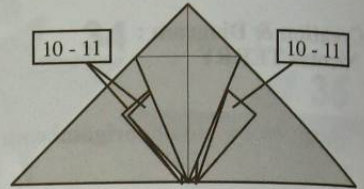

12. Repeat steps 10 to 11 for the 3 other flaps.

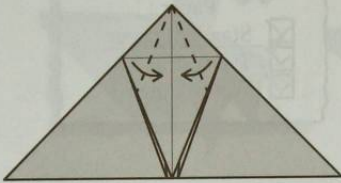

13. Fold along angle bisectors.

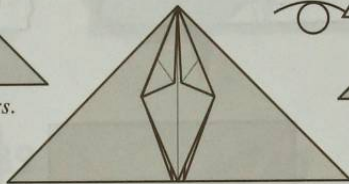

14. Turn the model over.

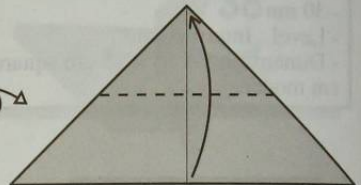

15. Fold the top layers in half.

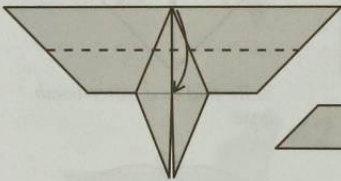

16. Valley-fold.

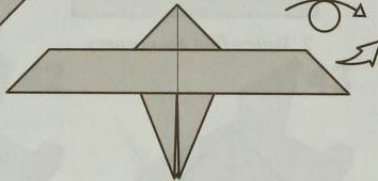

17. Turn the model over.

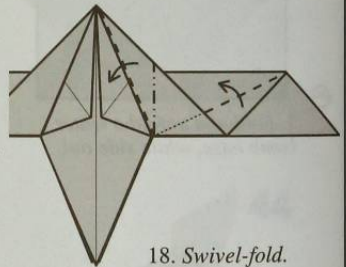

18. Swivel-fold.

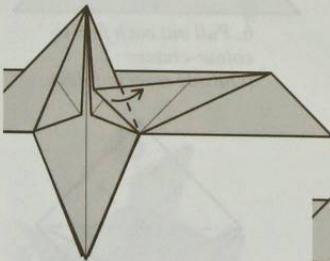

19. Valley-fold.

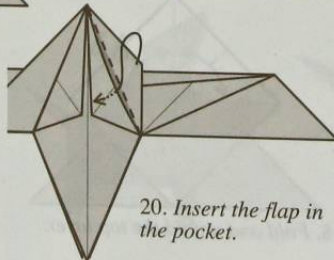

20. Insert the flap in the pocket.

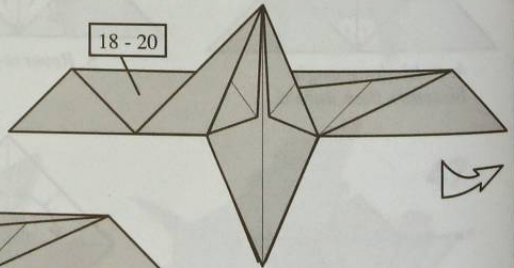

21. Repeat steps 18 to 20 for the other wing.

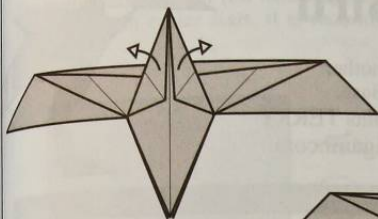

22. Unfold both flaps.

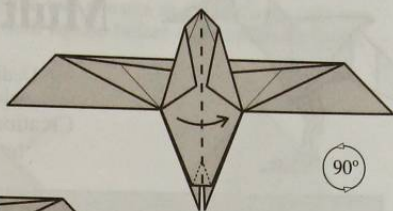

24. Valley-fold in half.

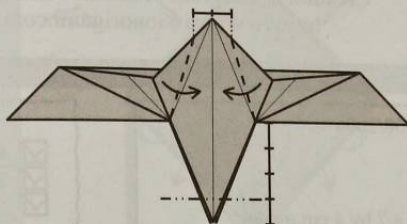

23. Fold the head flaps in. Mountain-fold the top layer of the tail.

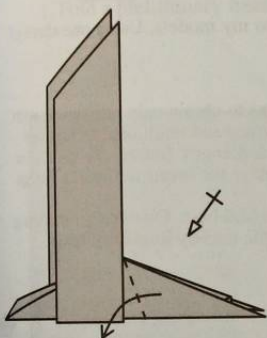

25. Valley-fold the legs. Check the next step for positioning.

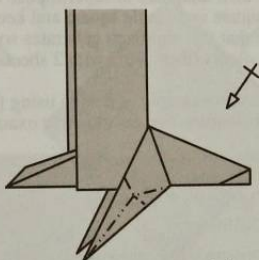

26. Rabbit's-ear on each leg (Double rabbit's-ear if you want).

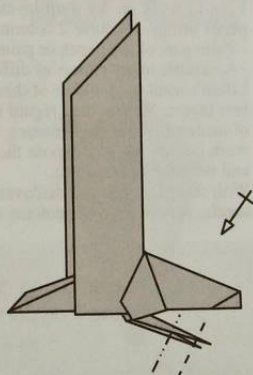

27. Shape each leg with mountain then valley-folds.

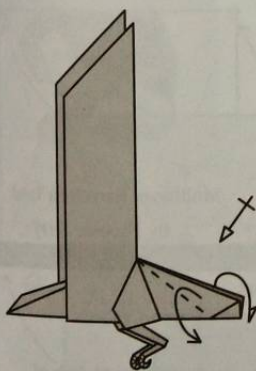

28. Outside reverse-fold the tail.

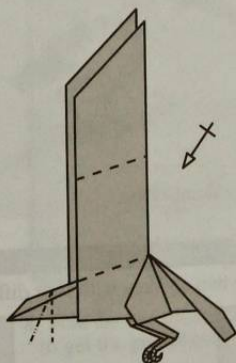

29. Shape the head with a crimp-fold. Don't forget the hooked beak! Shape the wings to taste.

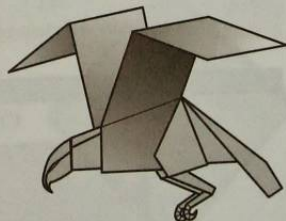

30. Finished eagle.

Multilayers Bird

Dedicated to my Grand-mother
who teach me the Bird Base.
Creation & Diagram : Nicolas TERRY
<http://www.passionorigami.com>

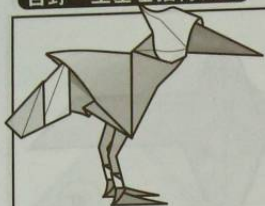

- Création # 46 / Date : 08/2004
- 30 min
- Level : Simple
- Dimension (R= 0,35) :
A 20 cm square makes a 7 by 4 cm model.

- Paper :
- Standard paper
 - Tissue-foil
 - Wet folding

I got to work on the multilayers concept because I wanted to add many colours to my models. Using one sheet of paper brings of course 2 colours, one on each face. To have more colours, we can :

- Paint part of the paper, or paint the finished model
 - Assemble many papers of different colours : this is the modular concept.
- I didn't want to go either of these ways. I then imagined to superimpose two squares to obtain only one square with two layers. We can then regard this new square as a single square and keep all the rules and traditional techniques of origami. What is interesting is the fact that this approach generates some new challenges. Indeed, we must now work on how we can expose the various colours (there are 4 with 2 sheets) and manage the layers during the design and the folding sequence.

With this bird, you can discover a multi-layers example of design using the classic bird base. Obviously, by adding sheets, you multiply the colours and the possibilities. See also an other example with the toad by Román Díaz. 88

The amazing courtship behaviour of the Polydermis nicolasus.

Recorded for the first time in their natural habitat, the couple stands over a sheet of paper. Note the indifference of the female while the male calls for her attention with a ritual dance.

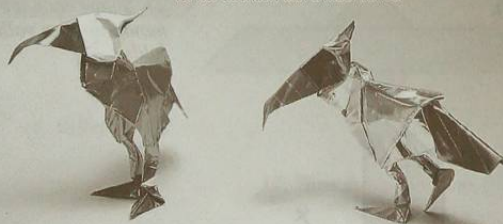

Text, folder and photographer : Román Díaz



Original Model : Toad by Román Díaz



Multilayer Barcelona Toad
by Nicolas Terry

Choose two squares with four different colours.

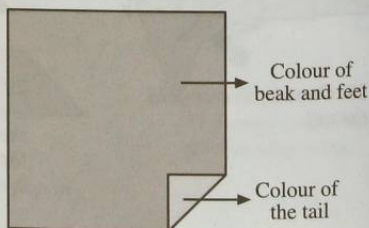
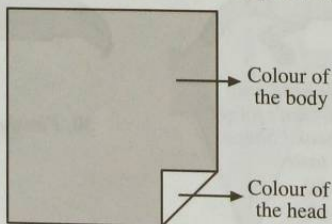

The multilayers concept [ou Multilayering] consists in folding the two squares as if they were only one. However, for an easier start, it is recommended to precrease each square before superimposing them.

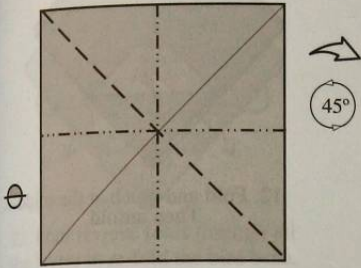

1. Fold a preliminary base.

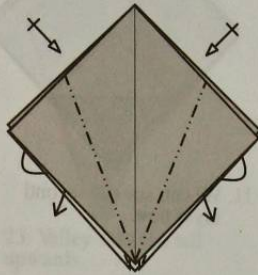

2. Four reverse folds.

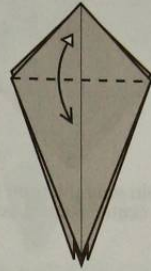

3. Fold and unfold. Then unfold the bird base completely.

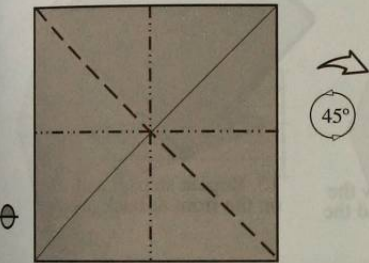

4. Fold a preliminary base.

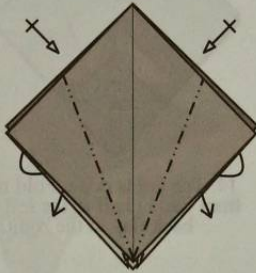

5. Four reverse folds.

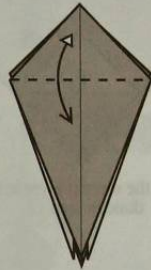

6. Fold and unfold. Then unfold the bird base completely.

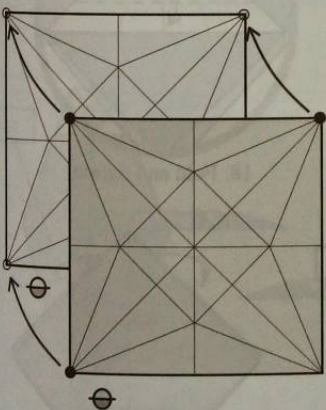

7. Superimpose the two squares while taking great care of colour positioning: place the colour of the body underneath and the colour of the tail on top.

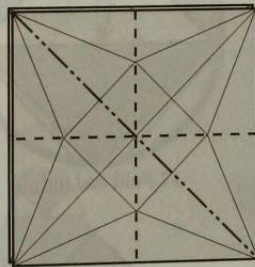

8. Fold the two squares together to get the preliminary base.

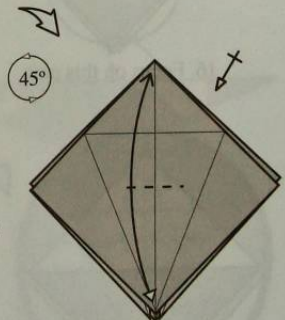

9. Fold the front layer to the top and pinch only at the middle. Then unfold. Repeat behind.

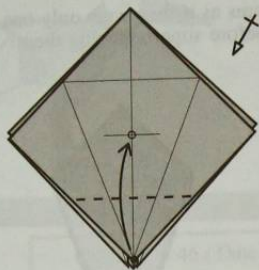

10. Fold only the front layer to the centre. Repeat behind

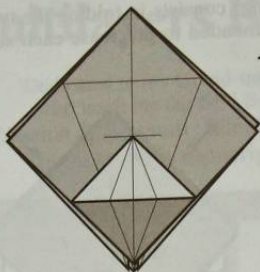

11. We can see the second layer now.

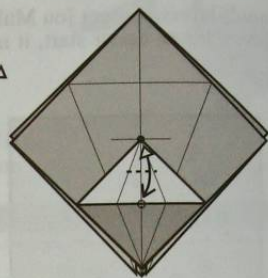

12. Fold and pinch at the middle. Then unfold.

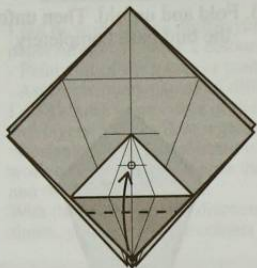

13. Fold the second layer to the mark done in step 12.

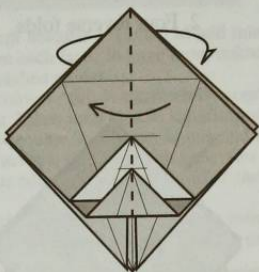

14. The tail is done. Fold now the front flap in half to the left and the back flap to the right.

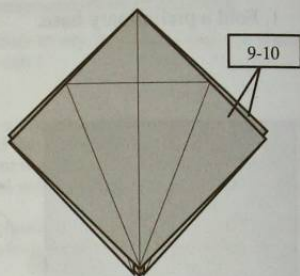

15. Repeat steps 9 and 10 on the front & back layers.

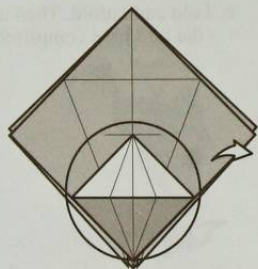

16. Focus on this part.

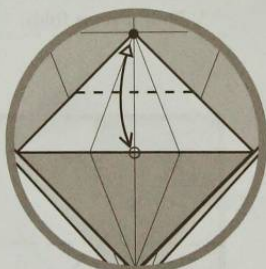

17. Fold and unfold.

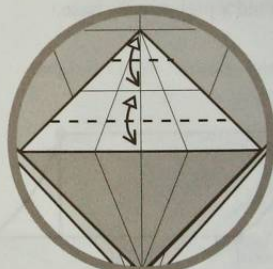

18. Fold and unfold.

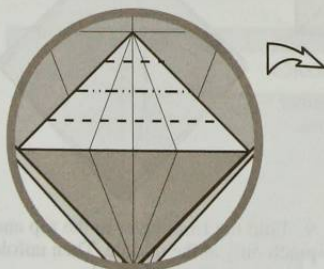

19. Pleat-folds.

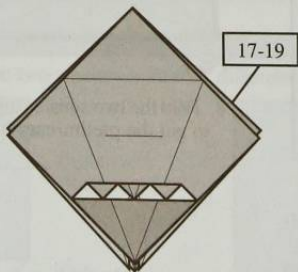

20. Repeat steps 17 to 19 behind.

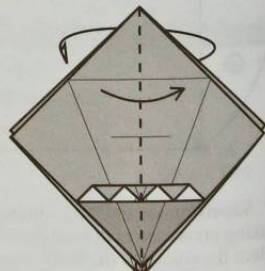

21. Fold now the front flap in half to the right and the flap behind to the left.

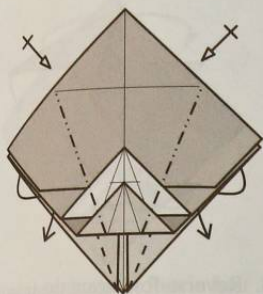

22. Four reverse folds through all the layers to re-fold the bird base.

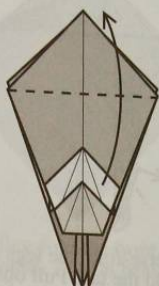

23. Valley-fold the tail upwards.

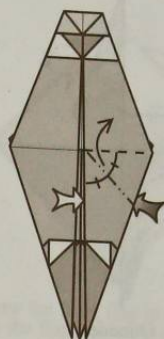

24. Squash-fold along angle bisector

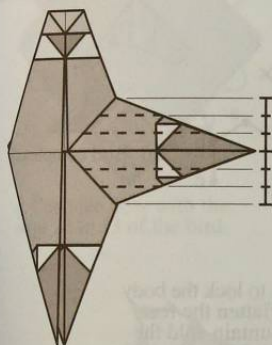

25. Fold in thirds each flap. Unfold.

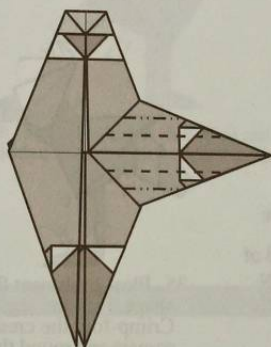

26. Pleat-fold each flap to thin the leg.

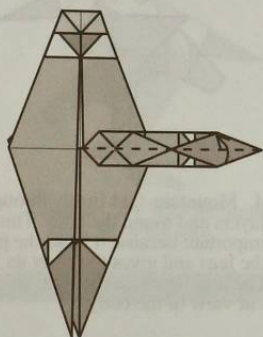

27. Valley-fold the leg to the top.

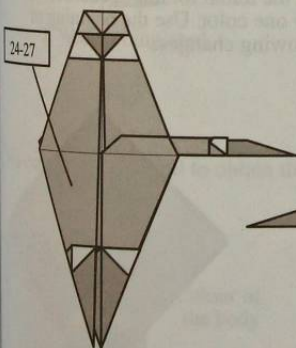

28. Repeat steps 24 and 27 on the left.

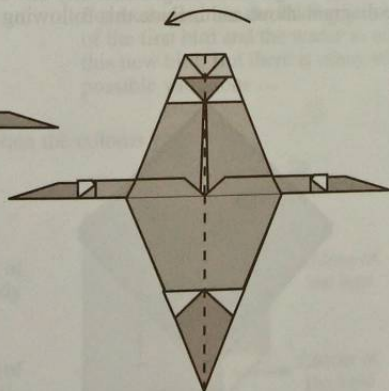

29. Fold the model in half to the left.

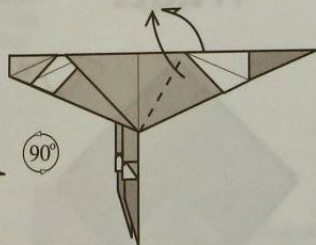

30. Outside reverse-fold for the neck

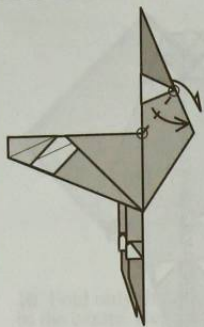

31. Outside reverse-fold.

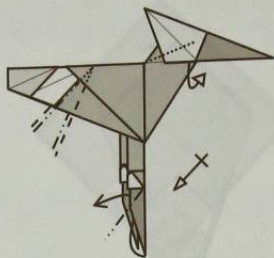

32. Reverse-fold the legs and crimp-fold the tail. Pull out the hidden flap for each side of the head.

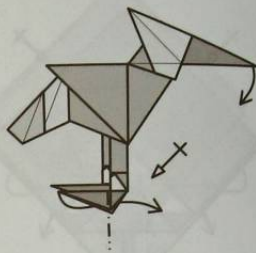

33. Reverse-fold again the legs and pull down the beak.

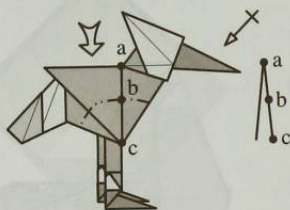

34. Mountain-fold firmly through all the layers and round the body. This fold is important because it locks the pleat-fold of the legs and gives the body its 3D shape. The line figure on the right side shows a cut view of the body.

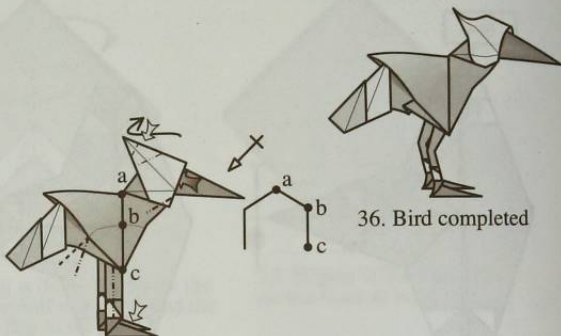

35. Pleat-folds near the tail to lock the body shape. Thin the legs and flatten the feet. Crimp-fold the crest. Mountain-fold the corners and round the head. Shape the body to taste.

36. Bird completed

Multilayer Wader

With the multilayers concept, we can have many variations. Here an example where with a small variation in the initial folding sequence, we can create wings and the legs have only one color. Use the beginning of the diagram above and include this following changes:

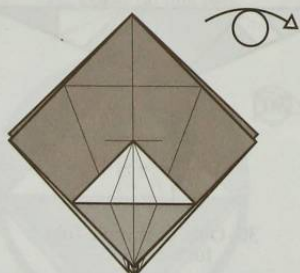

a. Fold the steps 1 to 11 of the bird. Turn over the model.

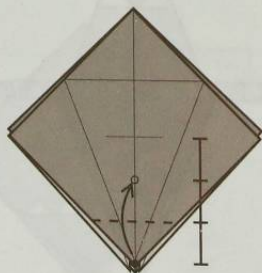

b. Fold only the front layer to the centre.

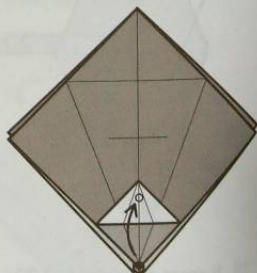

c. Fold the second layer

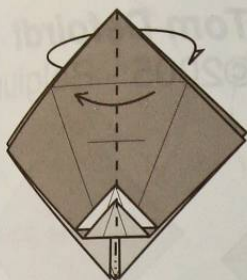

d. Fold now the front flap in half left and the flap behind to the right.

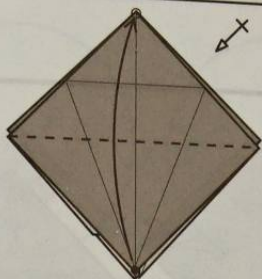

e. Valley-fold the front flap upwards. Repeat behind.

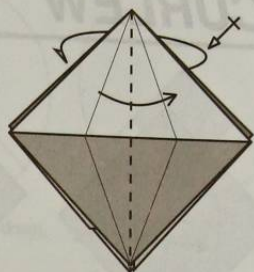

f. Fold now the front flap in half to the left and the flap behind to the right.

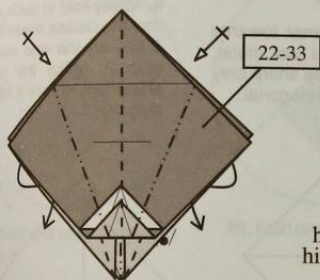

g. Continue now with the steps 22 to 33 of the bird.

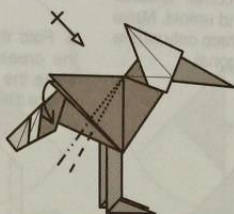

h. You should get this. Pull out the hidden wings with a pleat-fold inside.

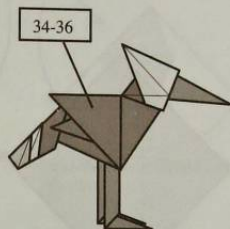

i. Continue now with the steps 34 to 36 of the bird.



J. Wader completed.

Others variations

Challenge : Add a third layer now and let guide itself by your imagination to create new birds more coloured even. For example, mix the folding sequences of the first bird and the wader to obtain this new bird. But there is many other possible variations ...



You can make tissue-foil to obtain the colours you wish.:

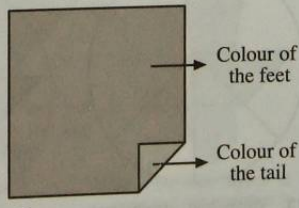
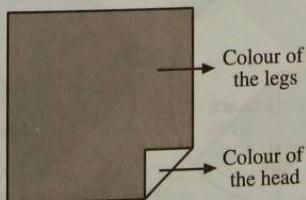
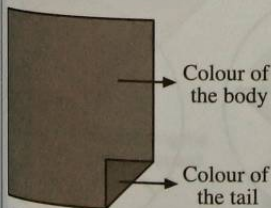

CURLEW

Tom Defoirdt
©2005 - Belgium

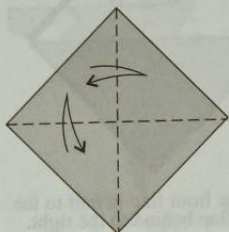

1. Fold and unfold along the diagonals.

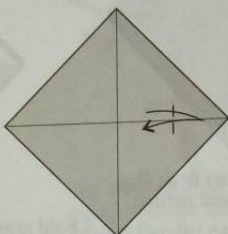

2. Fold the corner towards the center and unfold. Make the crease sharp only where it hits the diagonal.

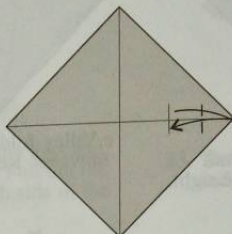

3. Fold the corner towards the crease you just made. Make the crease sharp only where it hits the diagonal.

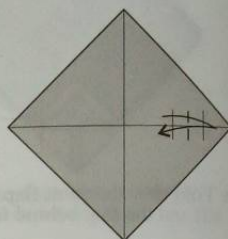

4. Valley-fold in such a way that the crease made in step 3 lies on the one made in step 2. Make the crease sharp only where it hits the diagonal and unfold.

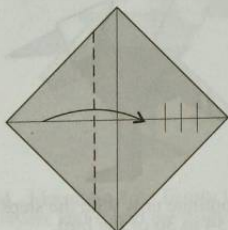

5. Fold the corner to the crease made in step 4.

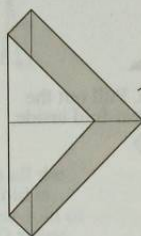

6. Turn over.

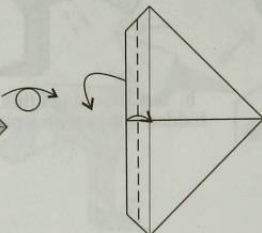

7. Fold the edge towards the center line, meanwhile bringing the left corner to the front.

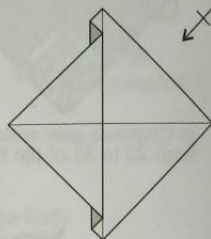

8. Repeat steps 2-7 at the right.

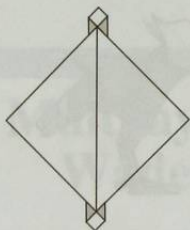

9. Like this.

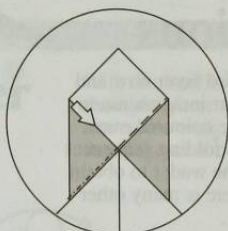

10. Enlarged view. Reverse-fold as indicated.

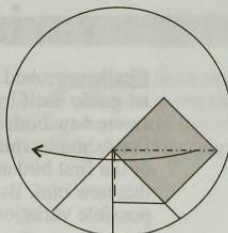

11. Squash-fold.

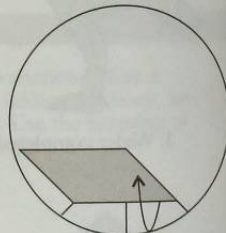

12. Bring one layer to the front.

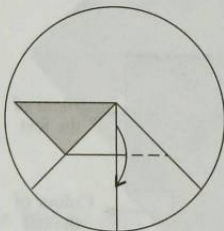

13. Valley-fold down one layer.

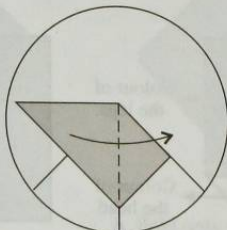

14. Fold the flap to the right.

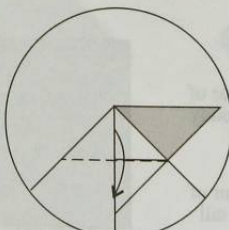

15. Valley-fold down one layer.

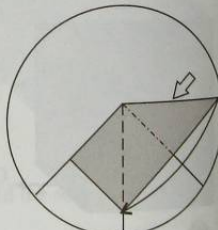

16. Squash-fold.

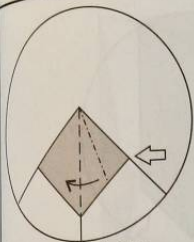

17. Squash-fold.

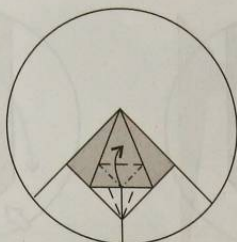

18. Petal-fold.

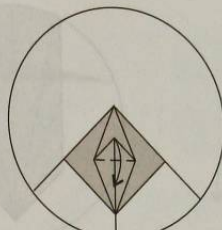

19. Fold the little flap down.

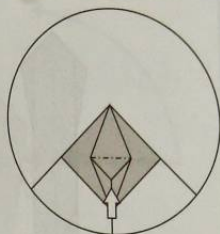

20. Sink the flap.

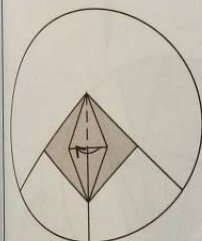

21. Fold one layer to the left in front.

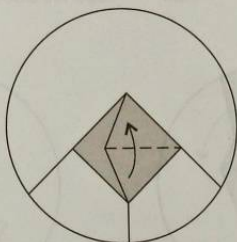

22. Fold one flap upwards.

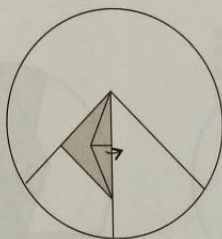

23. Fold two layers to the right.

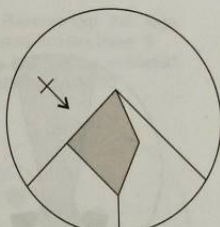

24. Repeat steps 17-23 at the left.

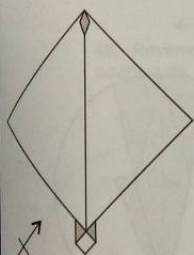

25. Repeat steps 10-24 at the bottom.

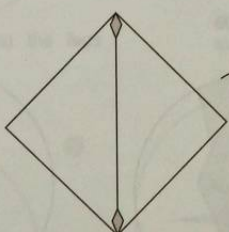

26. Like this. Turn over.

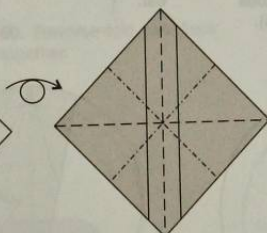

27. Enlarged view. Fold a preliminary base with the extra layers in the middle.

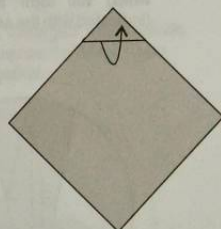

28. Enlarged view. Release the trapped layer. Repeat behind.

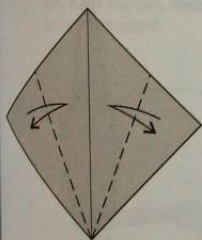

29. Fold and unfold along the angle bisectors. Repeat behind.

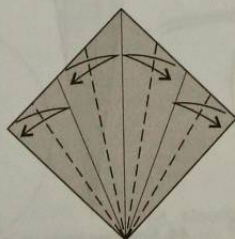

30. Fold and unfold along the angle bisectors. Repeat behind.

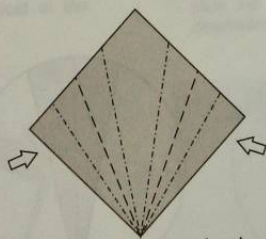

31. Open sink in and out along the creases you just made. Repeat behind.



32. Fold two layers to the right in front and two to the left behind.

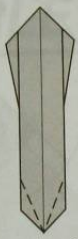

33. Fold and unfold along the angle bisectors. Repeat behind.

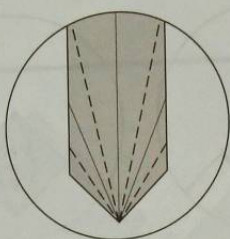

34. Enlarged view. Fold and unfold a long time along the angle bisectors. Repeat behind.

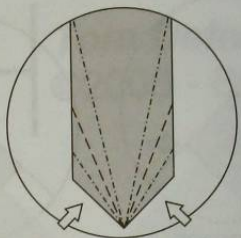

35. Open sink in and out on the creases you just made. Repeat behind.

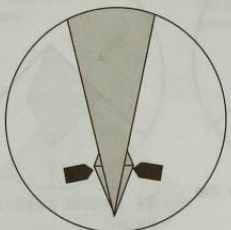

36. Like this. Next steps will focus on the small flaps which will form the toes (indicated with the arrows).

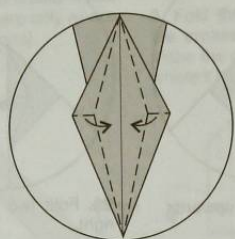

37. Enlarged view from the inside of the model. Rabbit ear.

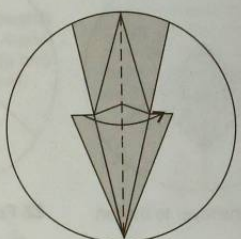

38. Fold two layers to the right.

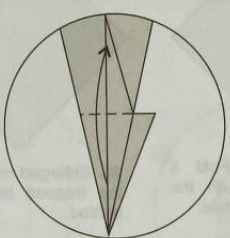

39. Fold one layer upwards.

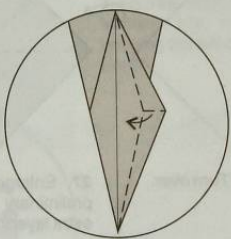

40. Rabbit ear.

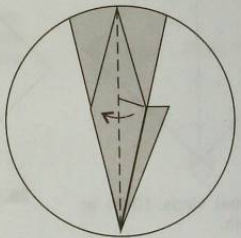

41. Fold the layers back to the left.

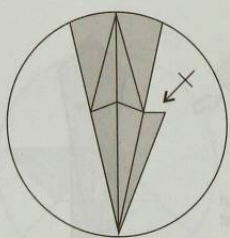

42. Repeat steps 38-41 at the right.

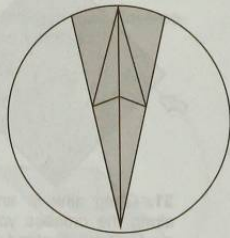

43. Like this. Repeat steps 37-42 at the other flap.



44. Fold one layer up in front as far as possible. Repeat behind.



45. Fold the model in half.

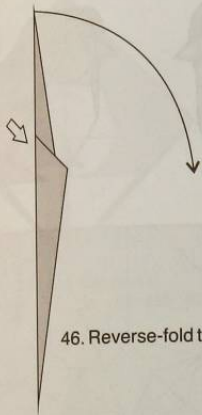

46. Reverse-fold the legs.

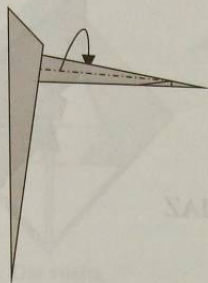

47. Mountain-fold the legs in half.

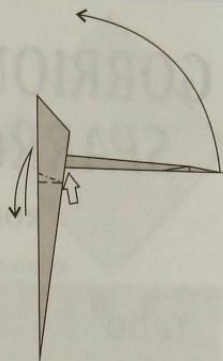

48. Reverse-fold the legs. Reverse-fold the lower 2 flaps together as indicated. Rotate the model 90°.

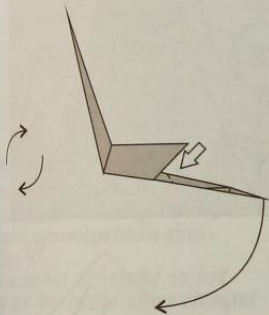

49. Reverse-fold the legs downwards.

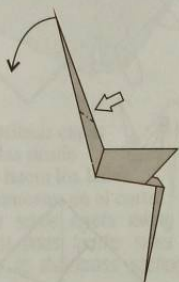

50. Reverse-fold two flaps together.

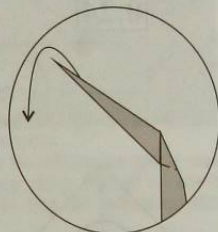

51. Enlarged view. Outside reverse-fold two flaps together.

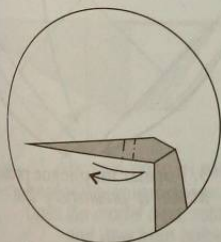

52. Fold the two flaps in and out as indicated.

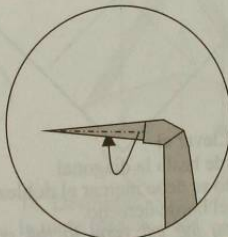

53. Mountain-fold the beak in half (squash-fold at the base).

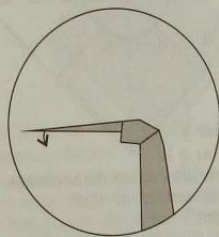

54. Round the beak and slide the lower jaw slightly downwards to open it.

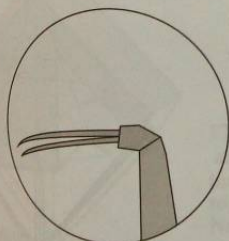

55. Like this.



56. Mountain-fold to shape the body. Spread the toes: three in front and one (the thickest one) behind.



57. Finished curlew.
Model: Tom Defoirdt, 2005
Diagrams: Tom Defoirdt, 2005
[Http://users.skynet.be/tomsorigami](http://users.skynet.be/tomsorigami)

GORRION SPARROW

ROMAN DIAZ

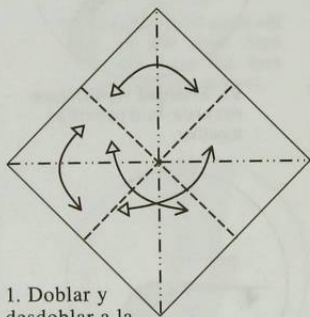
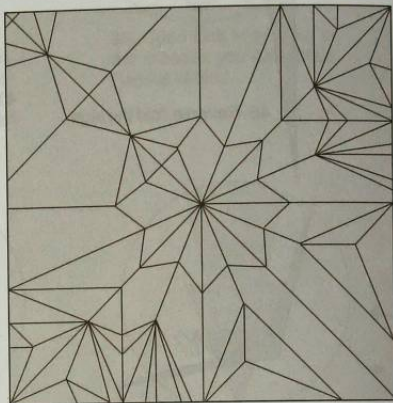
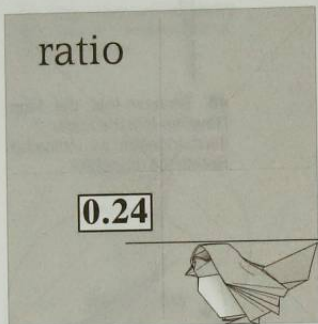
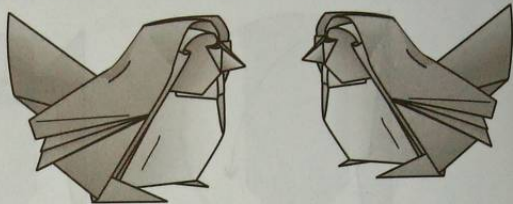

1. Doblar y desdoblar a la mitad en las cuatro direcciones.
Fold and unfold in half as shown.

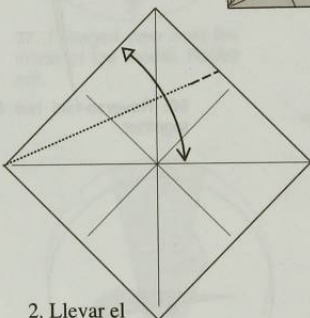

2. Llevar el borde hasta la diagonal. Sólo se debe marcar el doblez en el borde derecho.
Bring the left edge to the diagonal. Pinch only on the right edge.

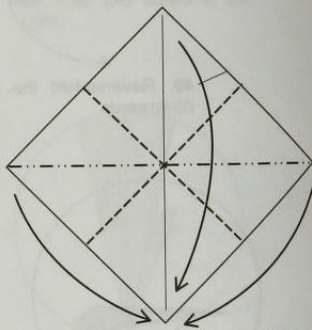

3. Formar un pliegue preliminar.
Make a preliminary fold.

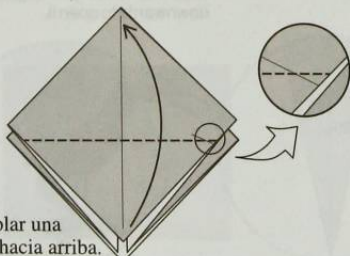

4. Doblar una punta hacia arriba. El doblez debe estar un par de mm por encima de la marca del paso 3.
Fold one point up. The crease should be a couple mm above the mark of step 3.

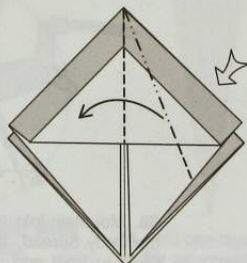

5. Abrir y aplastar una aleta.
Squash-fold a flap.

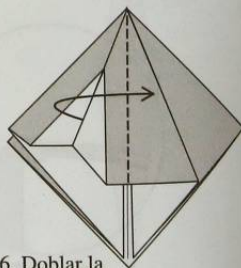

6. Doblar la aleta hacia la derecha.
Fold the flap to the right.

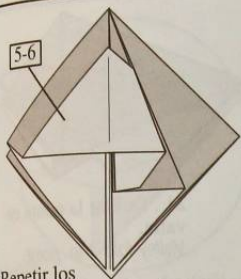

7. Repetir los pasos 5-6 del lado izquierdo.
Repeat steps 5-6 on the left side.

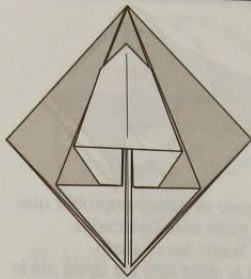

8. Dar vuelta.
Turn over.

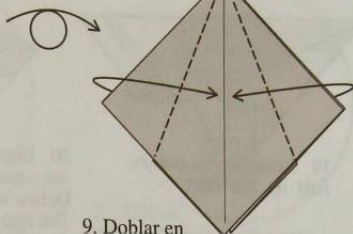

9. Doblar en valle las dos aletas hacia el centro.
Valley-fold the flaps on both sides to the centre.

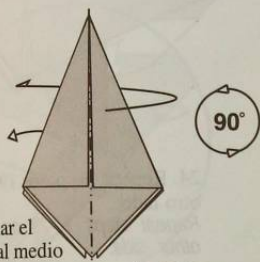

10. Doblar el modelo al medio en monte de manera que la capa central sobresalga hacia abajo.
Rotar 90°.
Mountain-fold the model in half so that the central colour-changed layer sticks out from below.
Rotate 90°.

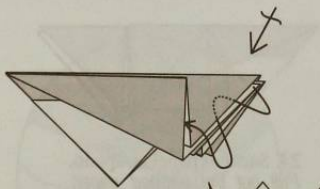

11. Redistribuir capas llevándolas desde el centro hacia los lados como se muestra en el corte.
Rearrange some layers taking the central ones to the sides as shown in the cross section.

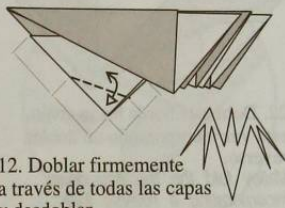

12. Doblar firmemente a través de todas las capas y desdoblar.
Usar las referencias que se muestran.
Create firmly through all layers and unfold. Use the references shown.

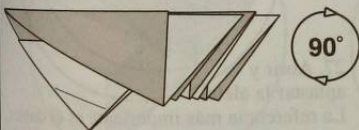

13. Abrir un poco el modelo, rotar 90° y mirar desde abajo.
Open the model a bit, rotate 90° and view from below.

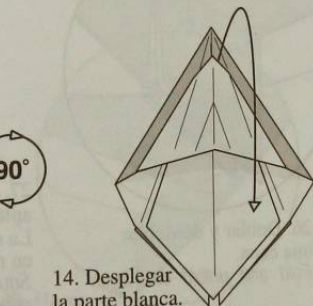

14. Desplegar la parte blanca.
Unfold the white part.

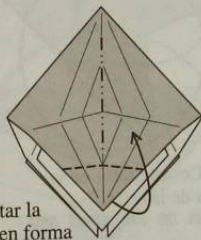

15. Notar la marca en forma de rombo que resultó del paso 12.
Levantar la punta donde comienza la marca pero no doblar firmemente.
Note the diamond shaped crease which resulted from step 12. Lift the point up where the diamond starts, but don't fold it.

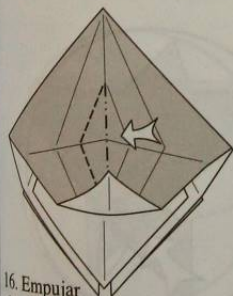

16. Empujar el rombo hacia un lado...
Push the little diamond to one side...

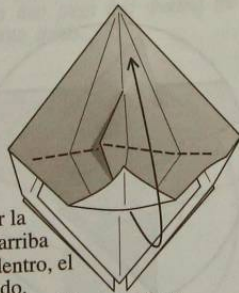

17. ...y cerrar la aleta hacia arriba incluyendo dentro, el rombo doblado.
Notar que la punta del paso 15 no quedará doblada.
...and close up the flap including the folded diamond inside. Note the point lifted in step 15 will not remain folded.

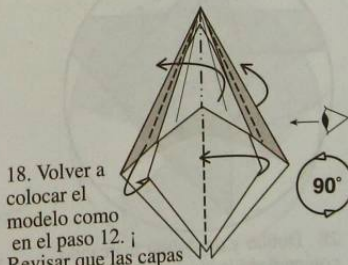

18. Volver a colocar el modelo como en el paso 12. ¡Revisar que las capas estén como en el corte!
Arrange the model as in step 12. Remember to check the cross section!

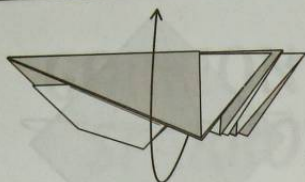

19. Levantar dos bordes.
Fold up two flaps.

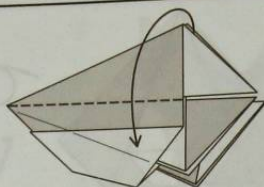

20. Este paso es para comprobar que las capas están bien colocadas. Doblar un borde hacia abajo.
This step is to make sure the layers are in the right place. Fold one edge down.

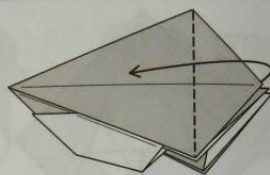

21. Doblar la punta en valle.
Valley-fold the point.

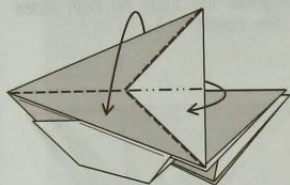

22. Doblar el borde hacia abajo, esta vez incorporando un doblez reverso.
Valley fold the the flap down, incorporating a reverse fold.

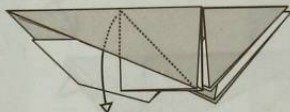

23. Sacar el papel atrapado.
Pull out the trapped paper.

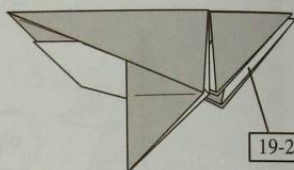

24. Repetir los pasos 19-23 del otro lado.
Repeat steps 19-23 on the other side.

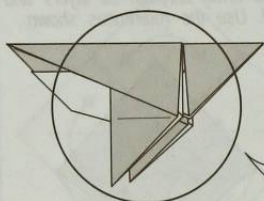

25. Concentrarse en la zona de las alas.
Focus on the wings and feet.

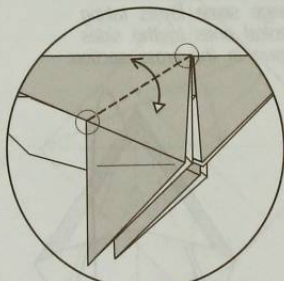

26. Doblar y desdoblar una capa.
Fold and unfold one layer.

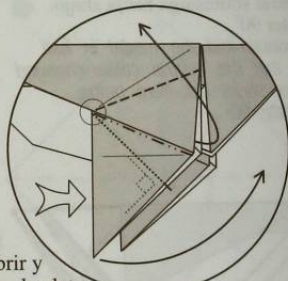

27. Abrir y aplastar la aleta.
La referencia más importante es el doblez en monte que corre a lo largo de un borde.
Squash-fold the flap. The most important reference is the mountain fold that lies along an edge.

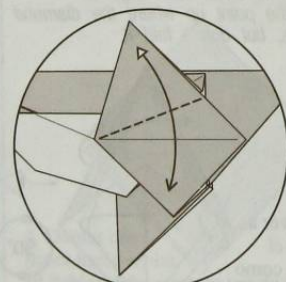

28. Doblar y desdoblar marcando con cuidado la "bisagra" de la aleta.
Fold and unfold taking care to create the flap where it hinges.

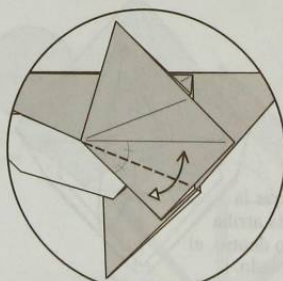

29. Doblar y desdoblar marcando la bisectriz del ángulo.
Fold and unfold marking the angle bisector.

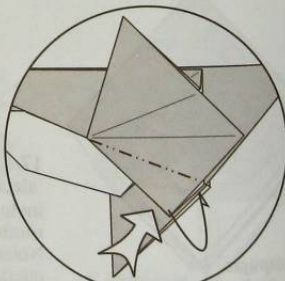

30. Revertir la esquina.
Reverse-fold the corner.

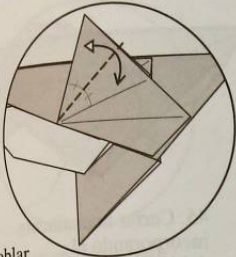

31. Doblar la bisectriz del ángulo y desdoblar.
Fold the angle bisector and unfold.

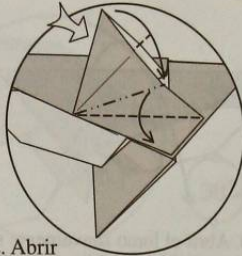

32. Abrir y aplastar la aleta. Observar las marcas que se usan.
Squash-fold the flap. Note the crease lines to use.

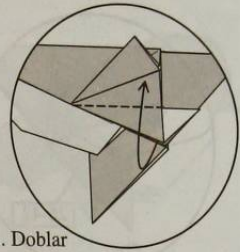

33. Doblar en valle subiendo un borde.
Valley-fold one flap up.

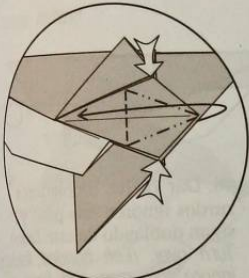

34. Doblar en pétalo.
Petal-fold the flap.

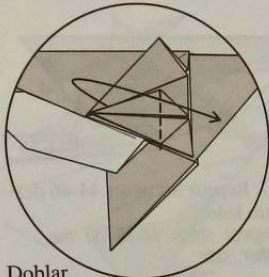

35. Doblar la aleta en valle hacia la derecha.
Valley-fold the flap to the right.

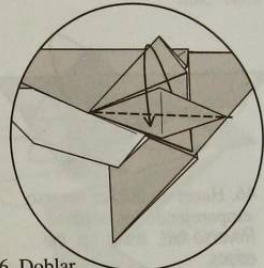

36. Doblar un borde en valle hacia abajo.
Fold the top flap down.

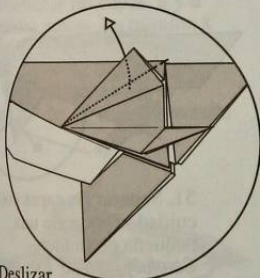

37. Deslizar papel hacia arriba utilizando la marca del paso 26.
Slide some paper upwards using the crease line from step 26.

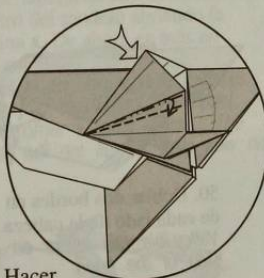

38. Hacer un doblez escalonado dividiendo el ángulo en tercios...
Make a thin pleat fold dividing the angle into thirds...

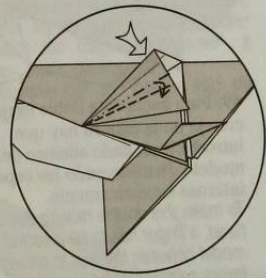

39. ... y otro del mismo ancho.
...and another one the same size.

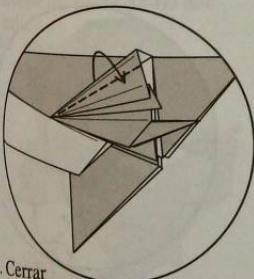

40. Cerrar la franja de papel sobrante sobre el ala.
Close the remaining strip of paper over the wing.

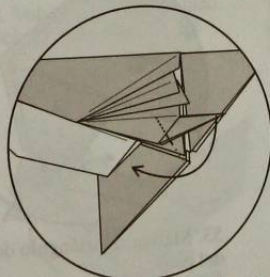

41. Revertir la pata hacia abajo.
Reverse-fold the foot down.

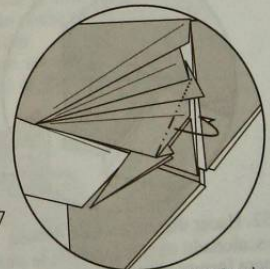

42. Deslizar una fina franja hacia adentro.
Slide a narrow strip in.

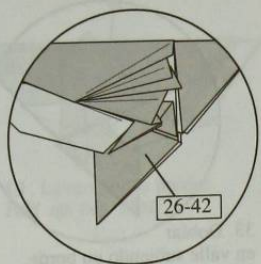

43. Repetir los pasos 26-42 del otro lado.
Repeat steps 26-42 on the other side.

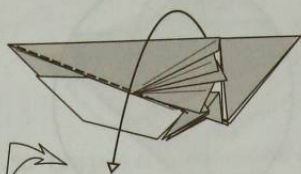

44. Abrir el lomo suavemente sin marcar dobleces.
Open the back gently trying not to leave crease marks.

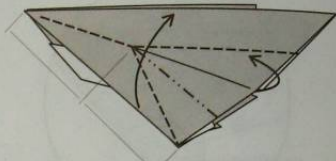

45. Cerrar nuevamente incorporando el doblez reverse que se muestra.
Close it up again incorporating the reverse-fold shown.

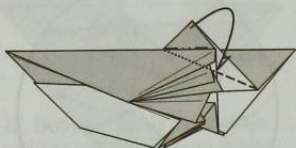

46. Hacer un doblez reverse emparejando los bordes.
Reverse-fold, lining up the edges.

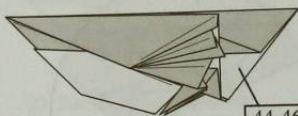

47. Repetir los pasos 44-46 del otro lado.
Repeat steps 44-46 on the other side.

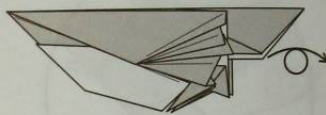

48. Dar vuelta. (dobladores zurdos ignoren este paso y sigan doblando de este lado)
Turn over. (Left handed folders ignore this step and keep folding on this side)



49. Para hacer esta doble oreja de conejo en la cabeza hay que introducir un dedo adentro del modelo distribuyendo las capas internas simétricamente.
To make this double rabbit's ear on the head, a finger has to be inserted into the model between the feet to arrange the layers symmetrically.



50. Doblar dos bordes en valle de cada lado de la cabeza.
Valley-fold two layers on each side of the head.

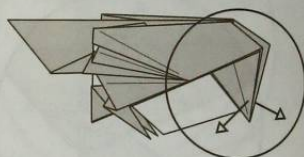

51. Separar las capas con cuidado formando una pequeña pirámide.
Carefully spread the layers to form a small pyramid.

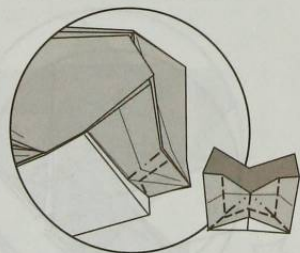

52. Hacer una especie de doblez escalonado en tres lados de la pirámide para formar el pico.
Make a kind of symmetrical crimp on three sides of the pyramid to form the beak.

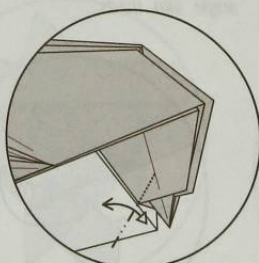

53. Marcar un triángulo debajo del pico...
Create a triangle just under the beak...

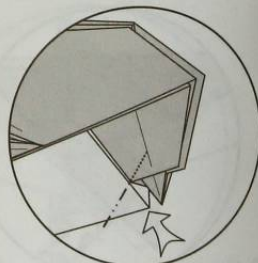

54. ...y hundirlo cerrado.
...and closed-sink it.

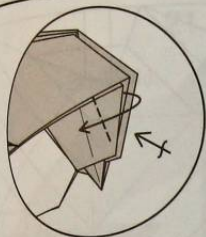

55. Enrollar un borde para formar el ojo.
 Repetir detrás.
*Roll up an edge to form the eye.
 Repeat behind.*

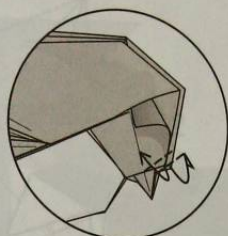

56. Doblar en valle dos pequeñas esquinas.
 Rotar un poco.
*Valley-fold the two little corners.
 Rotate a bit.*

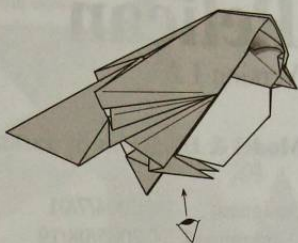
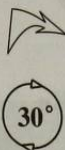

57. Mirar el modelo desde abajo.
Look from underneath.

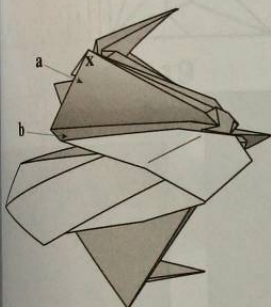

58. Identificar las capas **a** y **b** y tomarlas juntas. La esquina **x** servirá de referencia visual.
*Identify layers **a** and **b** and take them together. The **x** corner will be a visual reference*

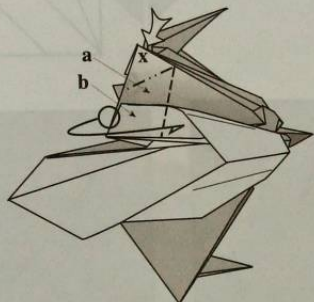

59. Las capas **a** y **b** están ahora juntas. Doblarlas en valle hacia adentro del modelo abriendo la esquina **x**. De ahora en más no quedará plano.
*Layers **a** and **b** are now together. Valley fold them into the model while corner **x** gets opened. The model will not lie flat from now on.*

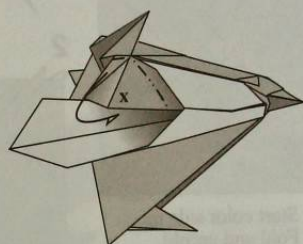

60. Notar que **a** y **b** están ocultas dentro del modelo y que la esquina **x** ha quedado abierta. Doblar la esquina en monte hacia adentro.
*Note layers **a** and **b** are hidden inside the model and corner **x** has been opened. Mountain-fold the corner into the model.*

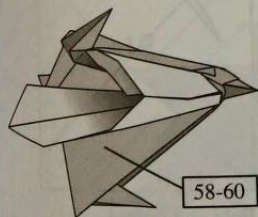

61. Repetir los pasos 58-60 del otro lado.
Repeat steps 58-60 on the other side.

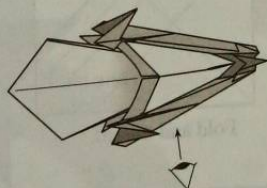

62. Volver a la vista de lado.
Back to side view.

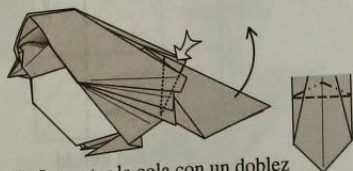

63. Levantar la cola con un doblez escalonado como se muestra en la vista auxiliar.
Lift the tail up with a crimp-fold like shown in the auxiliary view.

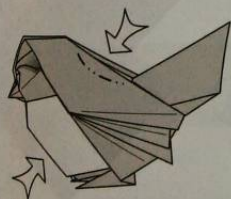

64. Redondear a gusto.
Round to taste.

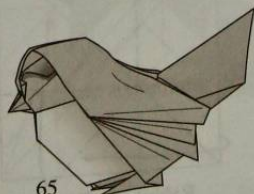

65

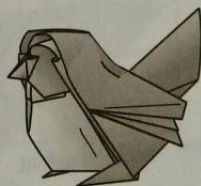

Pelican

Version 1.2

Model & Diagrams by Jason Ku

Designed: ©2004/7/01
Diagrammed: ©2005/08/19

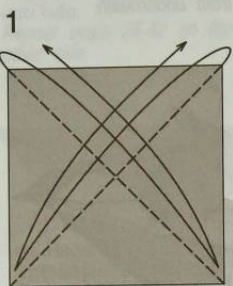
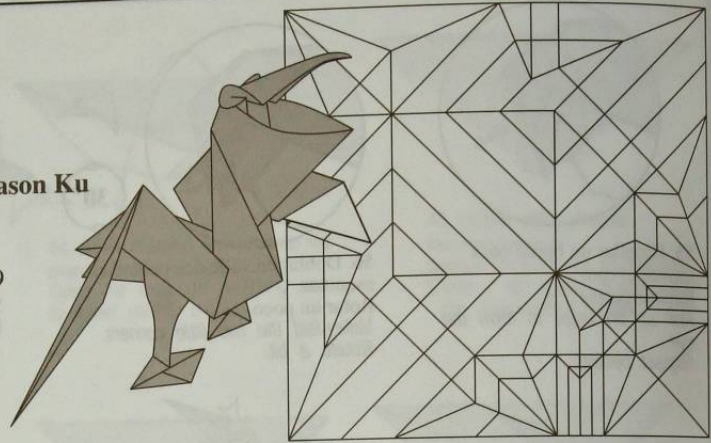

1 Start color side up.
Fold and unfold.

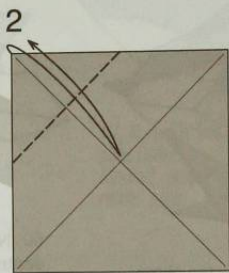

2 Fold and unfold.

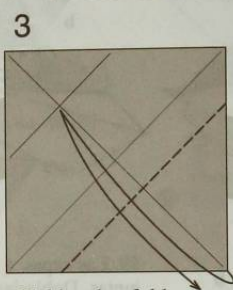

3 Fold and unfold.

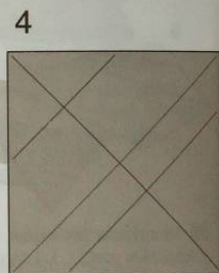

4 Turn over.

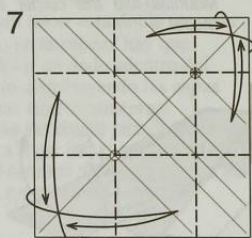

5 Fold and unfold.

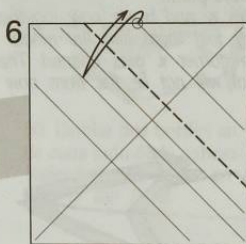

6 Fold and unfold.

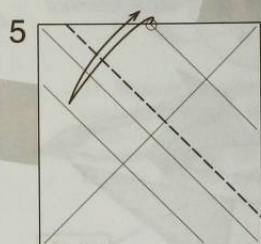

7 Fold and unfold.



8 Fold and unfold.

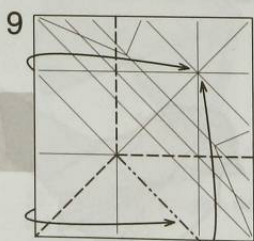

9 Rabbit-ear. Rotate.

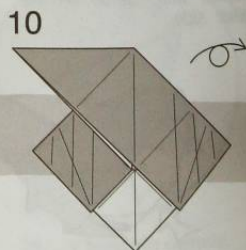

10 Turn over.

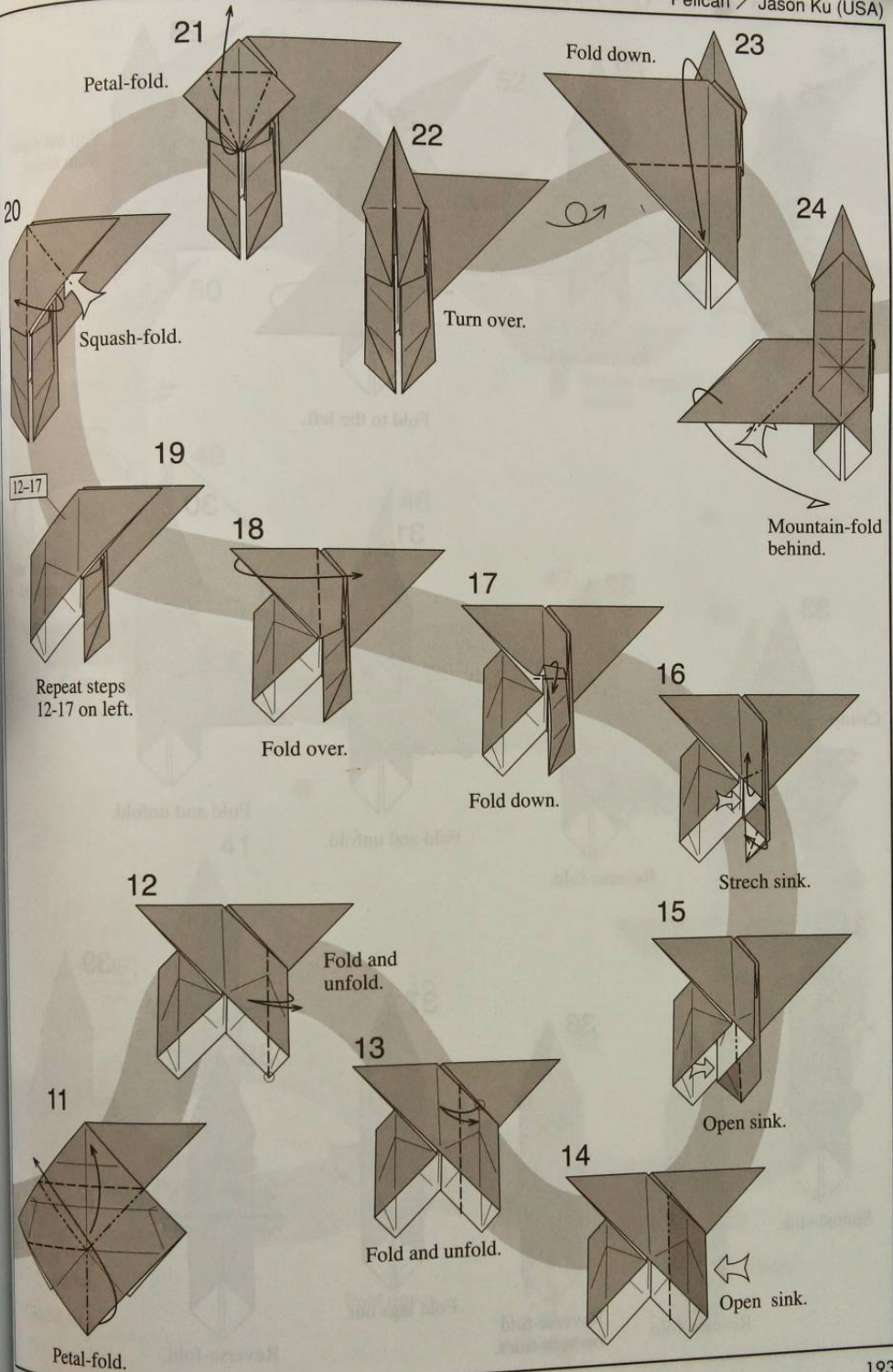

25

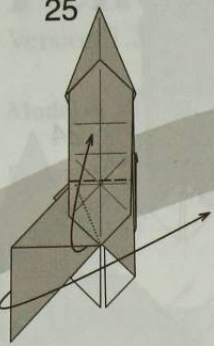

Squash-fold.

26

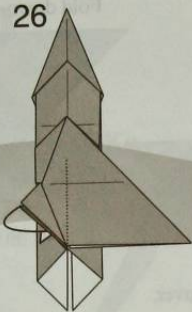

Reverse-fold.

27

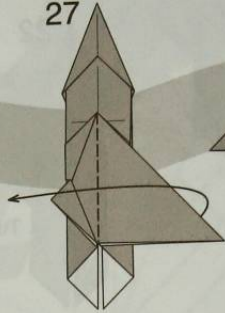

Fold to the left.

28

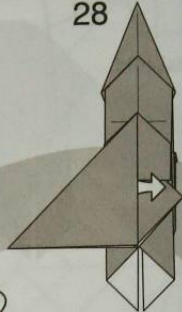

Pull out paper from inside.

29

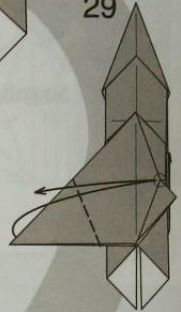

Fold and unfold.

33

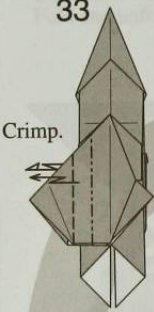

Crimp.

32

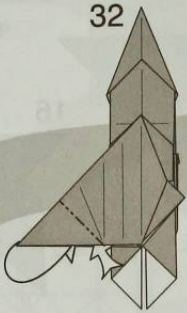

Reverse-fold.

31

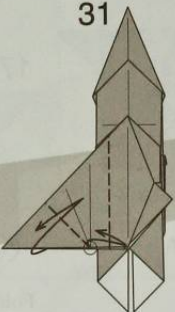

Fold and unfold.

30

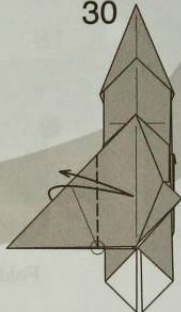

Fold and unfold.

34



Spread-sink.

35



Reverse-fold.

36



Reverse-fold on both sides.

37

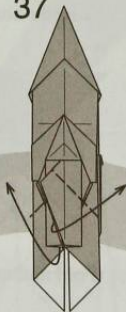

Fold legs out.

38

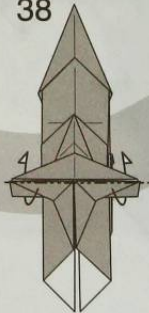

Reverse-fold.

39

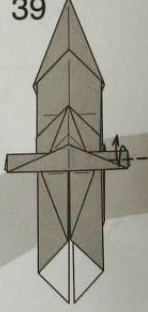

Fold and unfold.

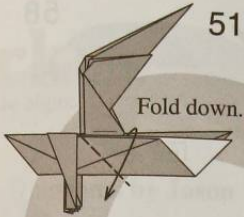

51

Fold down.

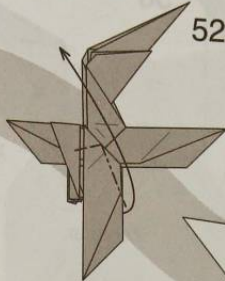

52

Squash-fold.

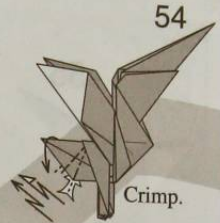

54

Crimp.



50

Fold wings to the right.

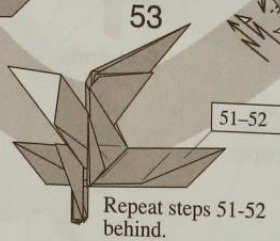

53

Repeat steps 51-52 behind.

51-52

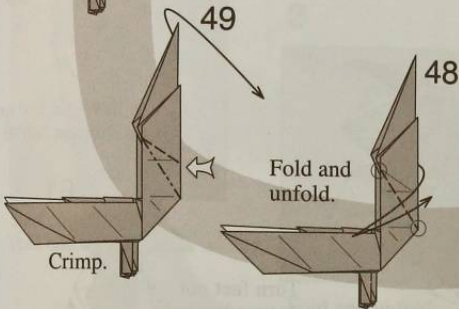

49

Fold and unfold.

Crimp.

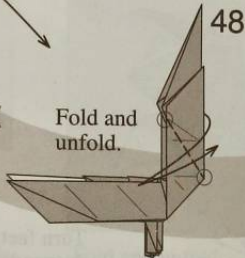

48

Fold and unfold.

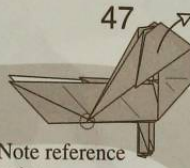

47

Note reference point. Unfold.

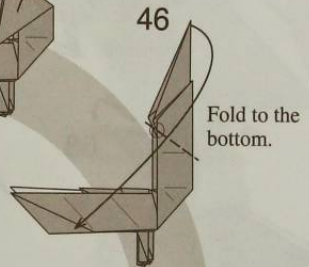

46

Fold to the bottom.

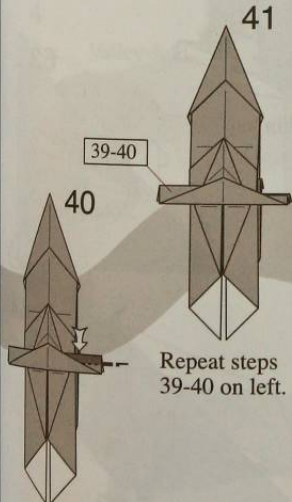

40

Repeat steps 39-40 on left.

41

Closed sink.

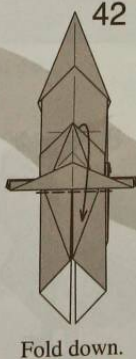

42

Fold down.

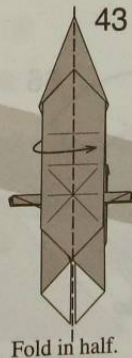

43

Fold in half.

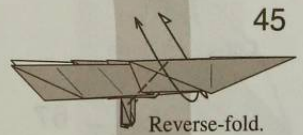

45

Reverse-fold.

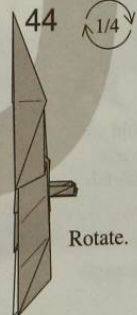

44

Rotate.

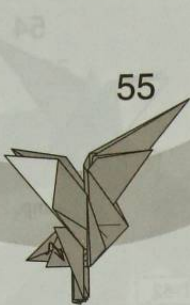

55

Pull out loose paper.



56

Fold down.

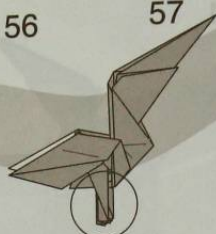

57

Zoom in.

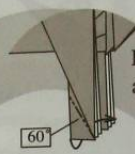

58

Reverse-fold at an angle of 60°.

60°

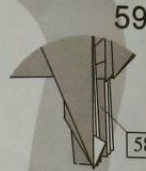

59

Repeat step 58 three times.



60

Valley-fold and spread up. Repeat behind.



69

Finished.

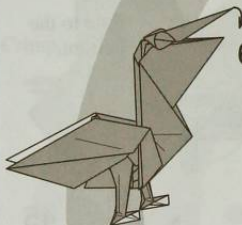
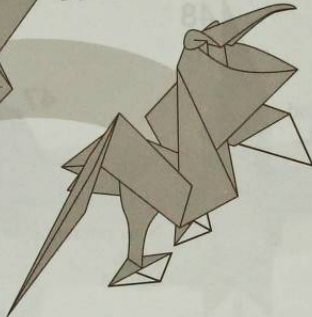

68

Curve beak down.

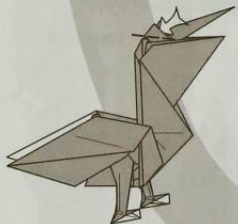

67

Squash-fold and round the eye. Repeat behind.



66

Crimp.

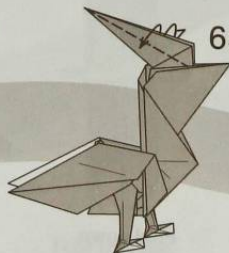

65

Valley-fold. Repeat behind.



62

Thin legs.



63

Zoom out.

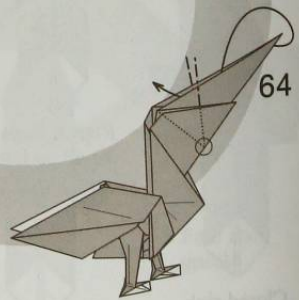

64

Reverse-fold.

Turkey

Version 1.1

Model & Diagrams by Jason Ku

Designed: ©2005/11/02

Diagrammed: ©2005/11/06

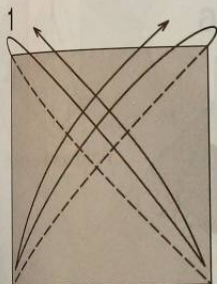
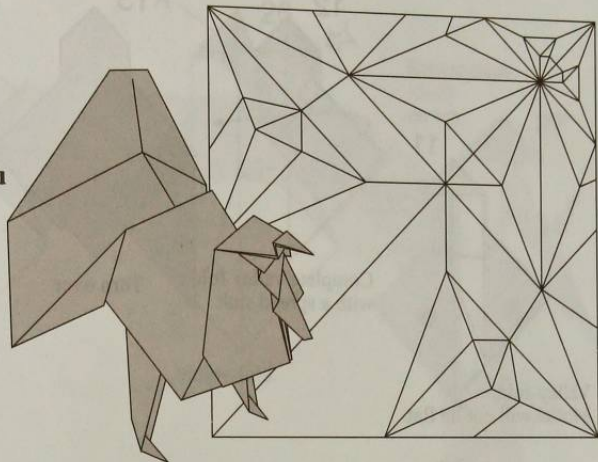

1 Start color side up. Fold and unfold.

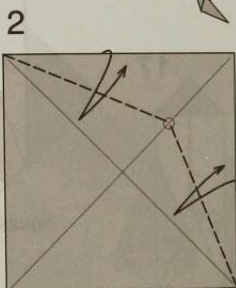

2 Fold and unfold.

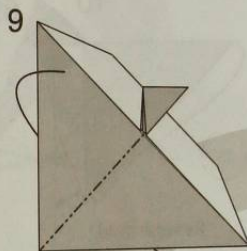

3 Mountain-fold. Rotate 45 degrees.

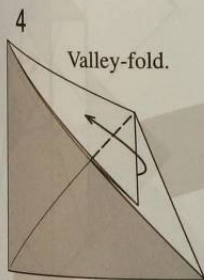

4 Valley-fold.

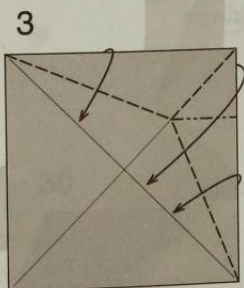

5 Rabbit-ear.

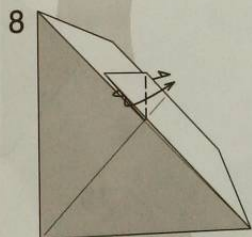

6 Outside reverse-fold.

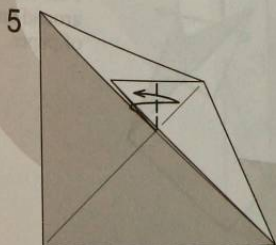

7 Fold and unfold.

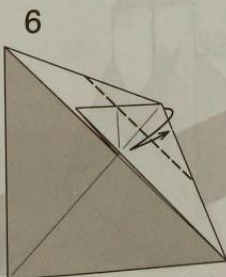

8 Fold and unfold.

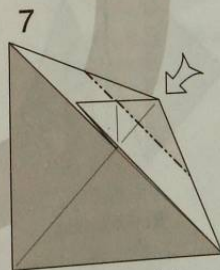

9 Open-sink.

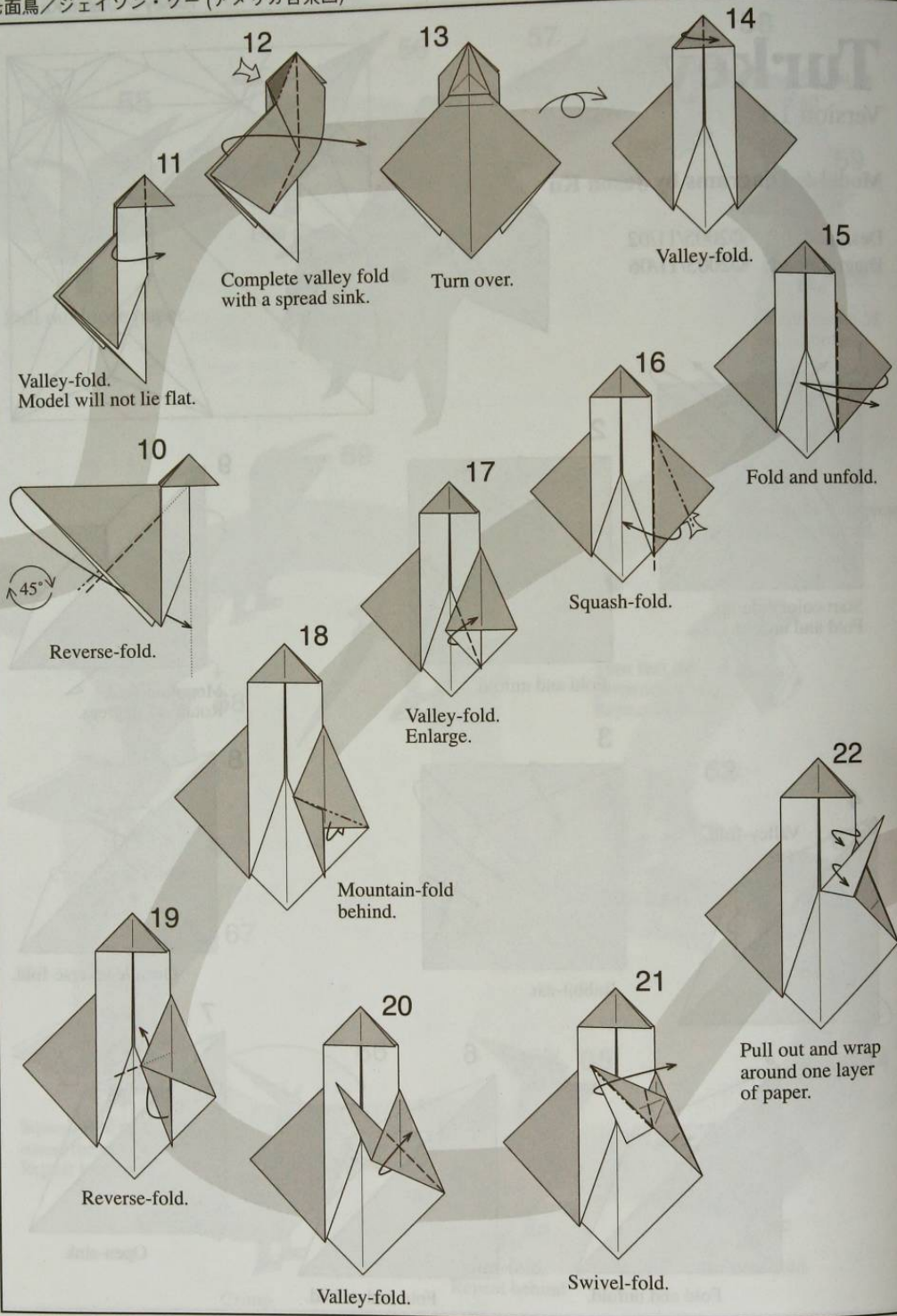

Mountain-fold behind leaving layer A in place.

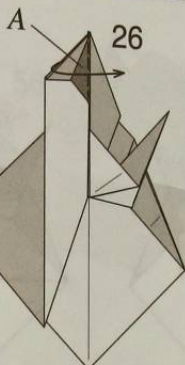
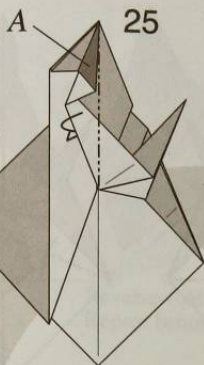

Repeat steps 15-25 on left.

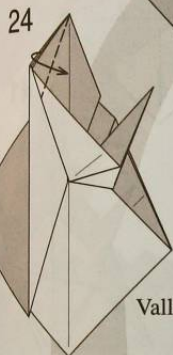
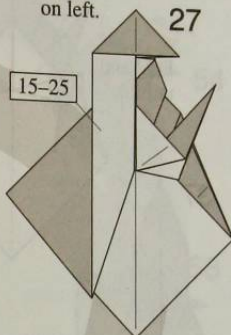

Valley-fold.

Valley-fold.



Unfold flap up.

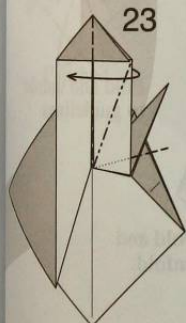

Swivel-fold.

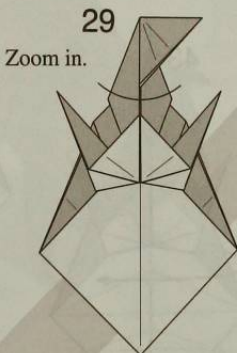

Zoom in.

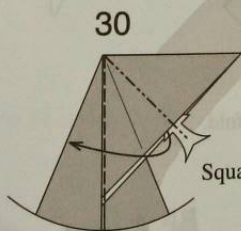

Squash-fold.

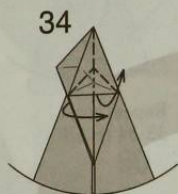

Valley-fold right and collapse back.

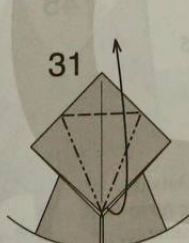

Petal-fold.

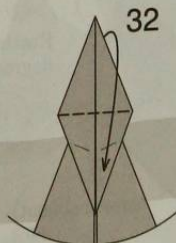

Valley-fold.

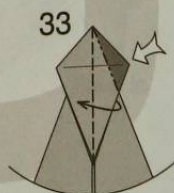

Spread-sink.

38

Fold and unfold.

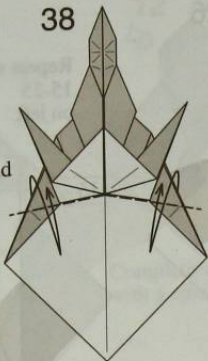

39

Fold and unfold.

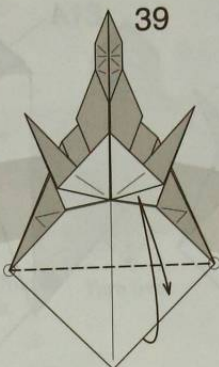

40

Fold and unfold along bisectors.

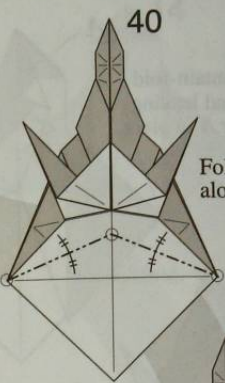

37

Zoom out.

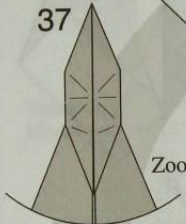

36

Valley-fold.

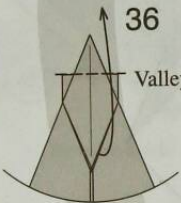

33-45

35

Repeat steps 33-34 on left.

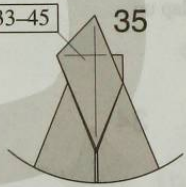

43

Valley-fold.

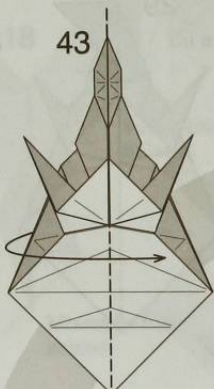

42

Fold and unfold to guidelines.

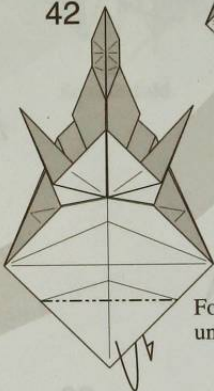

Fold and unfold.

46

Crimp.

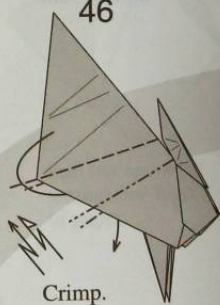

44

Rotate 135 degrees.



Outside reverse-fold. Enlarge.



45

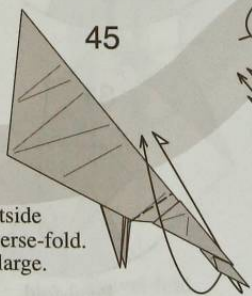

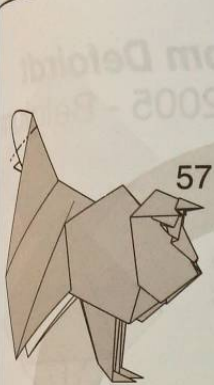

57

Reverse-fold.

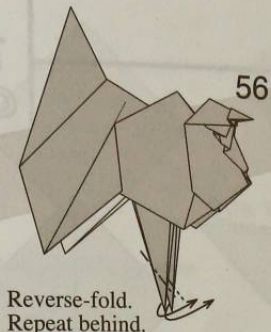

56

Reverse-fold.
Repeat behind.



55

Zoom out.



54

Crimp.

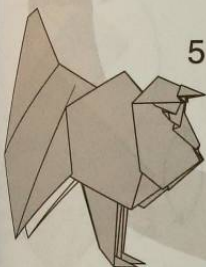

58

Finished.

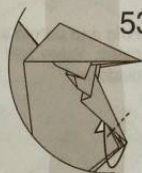
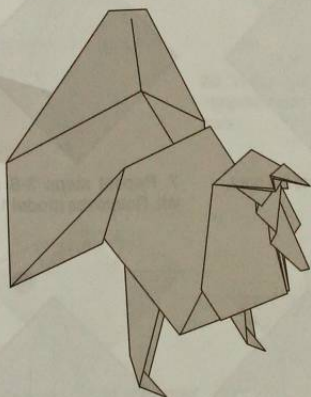

53

Reverse-fold.

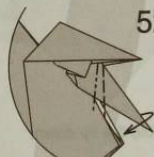

52

Crimp.

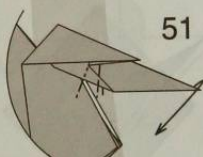

51

Crimp.

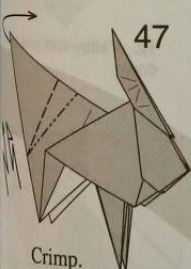

47

Crimp.

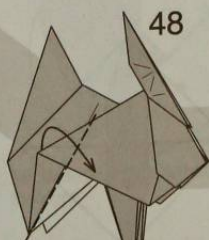

48

Valley-fold.
Repeat behind.

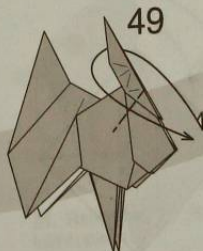

49

Outside reverse-fold.

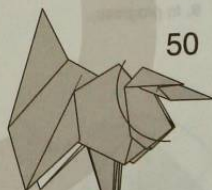

50

Zoom in.

BAT

Tom Defoirdt
©2005 - Belgium

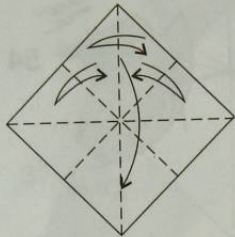

1. Fold and unfold as indicated. Valley fold along the diagonal.

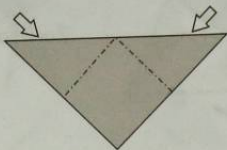

2. Reverse-fold.

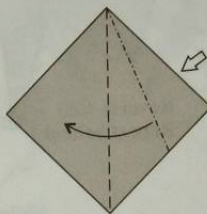

3. Enlarged view. Squash-fold.

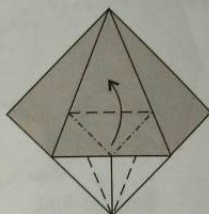

4. Petal-fold.

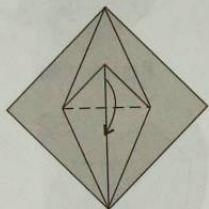

5. Fold the tip down.

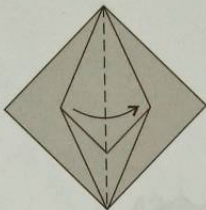

6. Fold one layer to the right.

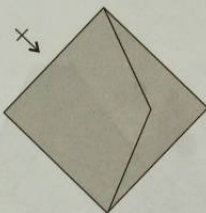

7. Repeat steps 3-6 at the left. Rotate the model 180°.

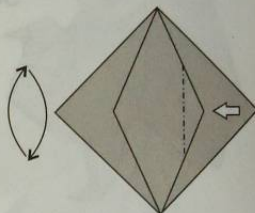

8. Fold the tip to the center line and open sink. Be careful not to trap the small tip.

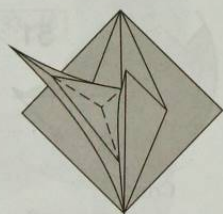

9. In progress...

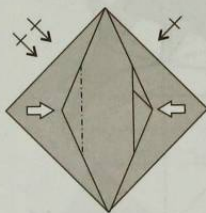

10. Repeat steps 8-9 at the three other layers (one at the right and two at the left).

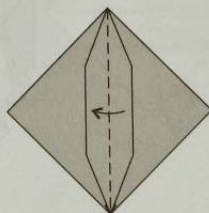

11. Fold two layers to the left in front.

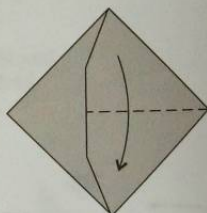

12. Valley-fold one layer down.

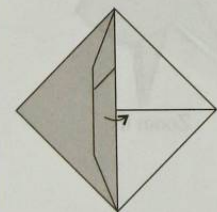

13. Fold the two layers back to the right.

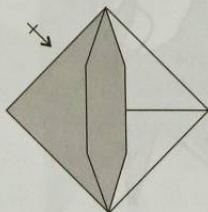

14. Repeat steps 11-13 at the left.

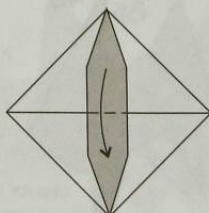

15. Valley-fold one layer down.

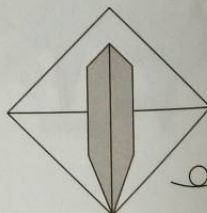

16. Turn the model over.

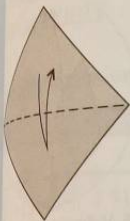

17. Fold and unfold.

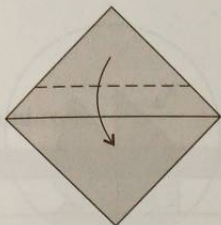

18. Valley-fold the top layer down.

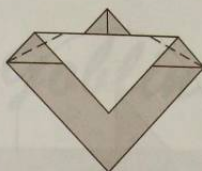

19. Fold and unfold along the angle bisectors.

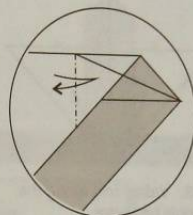

20. Enlarged view. Mountain-fold and unfold. Repeat at the left.



21. Fold the paper underneath using existing creases. Repeat at the left.

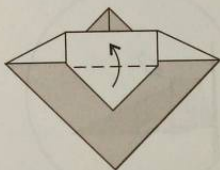

22. Valley-fold one layer upward.

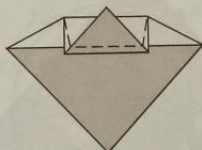

23. Valley-fold as indicated, meanwhile creating two rabbit ears.

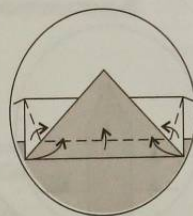

24. Enlarged view. Fold the two little tips that are created towards the center.

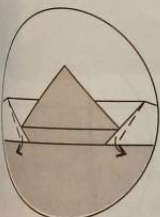

25. Valley-fold the small tips as indicated and flatten everything.

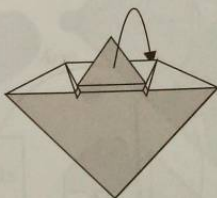

26. Mountain-fold the upper part of the model into the pocket behind.

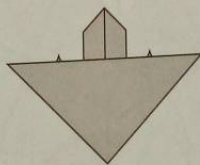

27. Like this. Turn over.

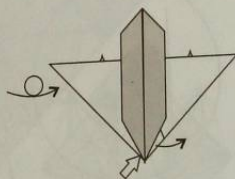

28. Reverse-fold one layer.



29. Enlarged view. Valley-fold the tip towards the center, meanwhile mountain-folding it in half.

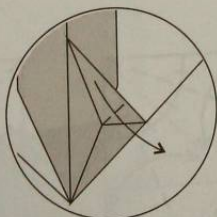

30. Valley-fold the tip back to the right.

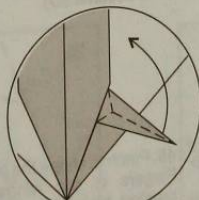

31. Rabbit-ear the tip and fold it upwards.

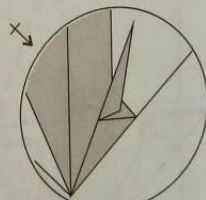

32. Like this. Repeat steps 28-31 at the left.

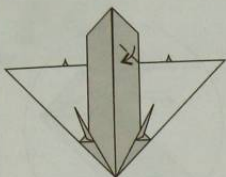

33. Valley-fold along the angle bissector.

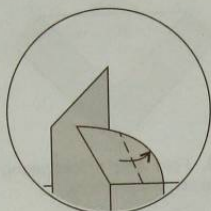

34. Enlarged view. Valley-fold the tip back to the right. The tip will not lie flat.

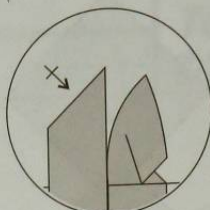

35. Repeat steps 33-34 at the left.

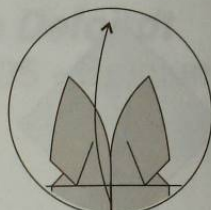

36. Valley-fold the large flap upwards.

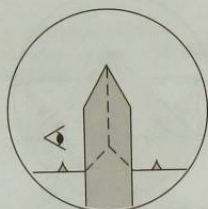

37. Rabbi-ear. Do not swing the flap to one of the sides; the model will not be flat. In the next steps, the flap is shown from the left side.

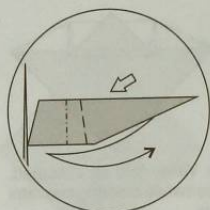

38. Enlarged view. Reverse-fold in and out.

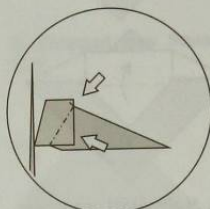

39. Reverse-fold. Repeat the lower one behind.

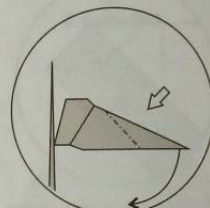

40. Reverse-fold downward.

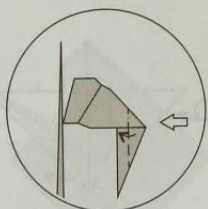

41. Fold the flap in half (reverse-fold at the top). Repeat behind.

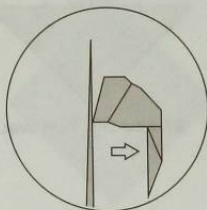

42. Push to the right from the inside to flatten the flap (the head will become 3D).

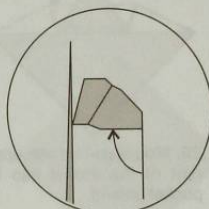

43. Fold the tip inside.

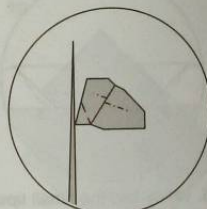

44. Pinch to shape the head. Repeat behind.

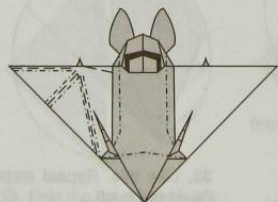

45. Pinch to shape the body. Fingers in the wings are created by one valley fold between two mountain folds. Legs are created by valley-folding the little tips down and up again.

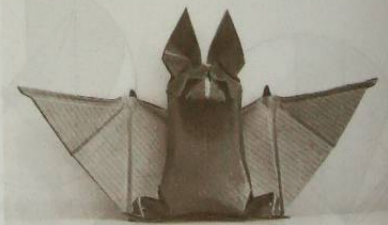

46. Finished bat.
Model: Tom Defoirdt, 2001
Diagrams: Tom Defoirdt, 2005
[Http://users.skynet.be/tomsorigami](http://users.skynet.be/tomsorigami)

Creation & Diagram :
Nicolas TERRY

Goblin

<http://www.passionorigami.com>

Creation # 71 / Date : 07/2005 2h30
Level : Complex
Dimension (R= 0,32) :

Paper :
 No Standard paper
 Tissue-foil
 No Wet folding

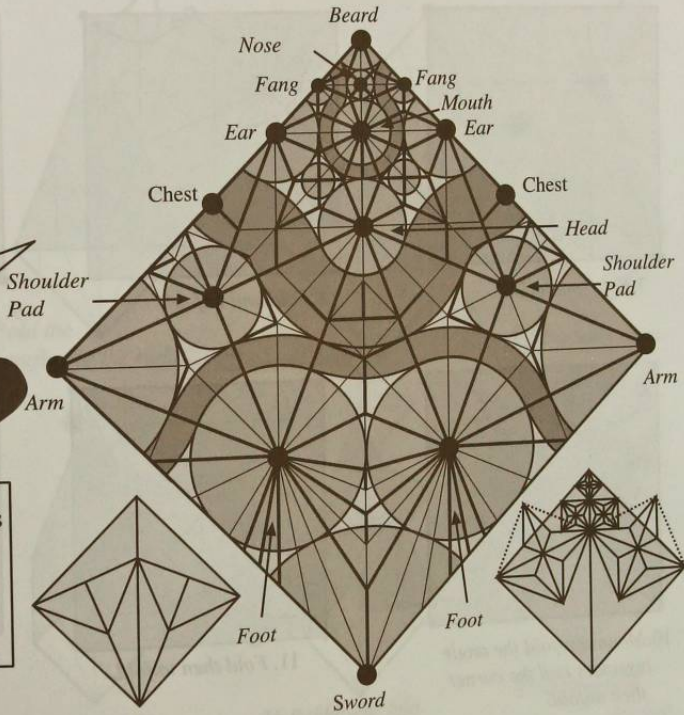

Given the complexity of this model, it would be worth trying a 30 or 40cm square the first time you fold it.

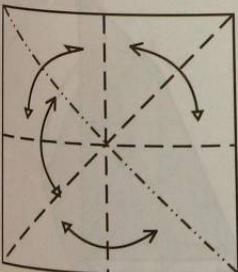

1. Crease as shown above.

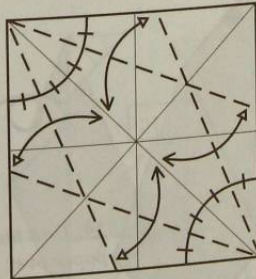

2. Crease the angle bisectors.

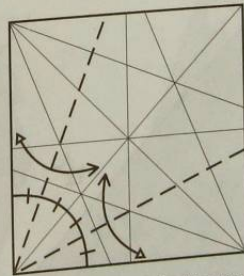

3. Crease the angle bisectors.

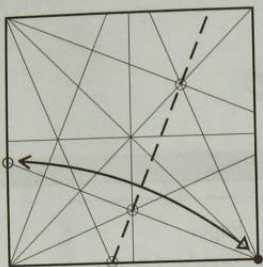

4. Fold and unfold. Note the reference points for the fold, then unfold.

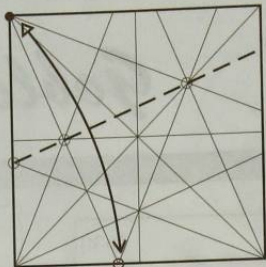

5. Repeat step 4 on the other corner.

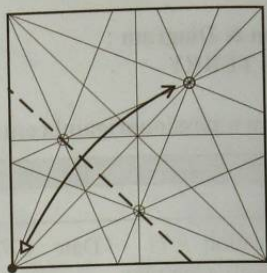

6. Fold and unfold. Turn the paper over.

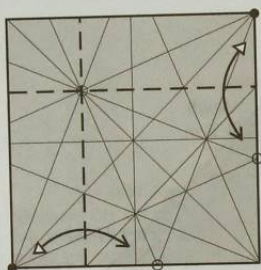

7. Fold and unfold.

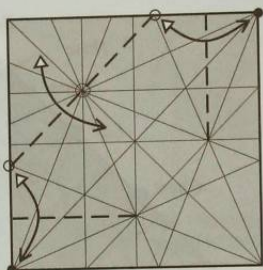

8. Fold and unfold.

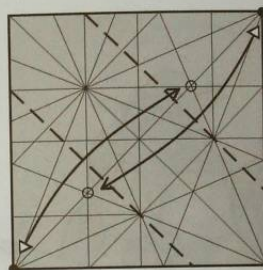

9. Fold and unfold.

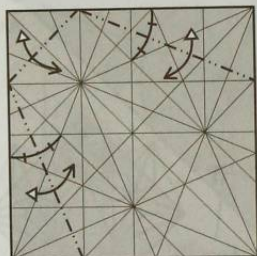

10. Mountain-fold the angle bisectors and the corner then unfold.

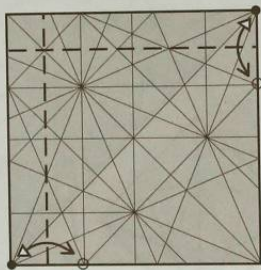

11. Fold then unfold.

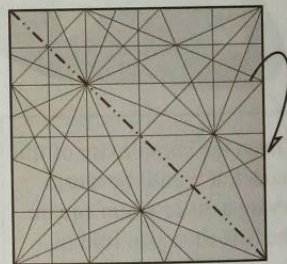

12. Mountain-fold in half.

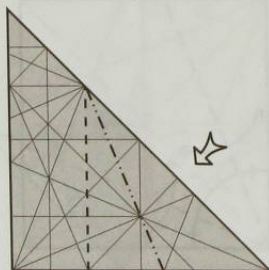

13. Squash-fold.

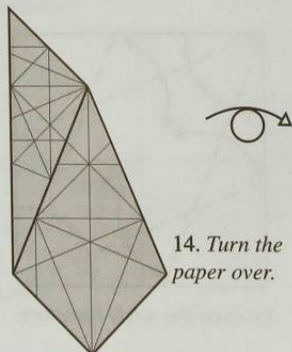

14. Turn the paper over.

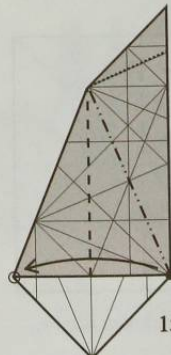

15. Swivel-fold.

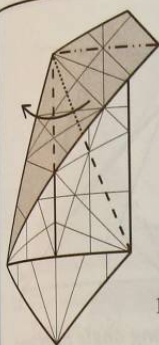

16. Swivel-fold.

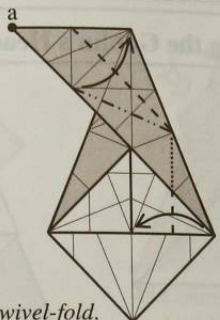

17. Swivel-fold.
The tip "a" becomes 3D.

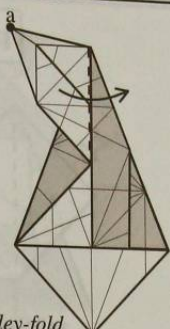

18. Valley-fold
the tipto the right.

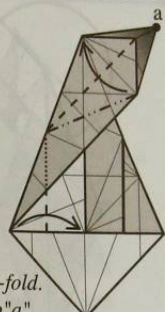

19. Swivel-fold.
The tip "a" becomes flat again.

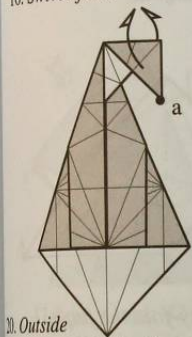

20. Outside
reverse-fold the tip.

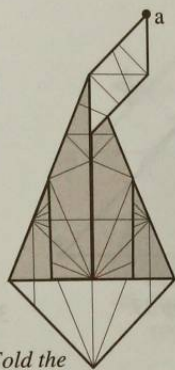

21. Fold the
front flap to the right.

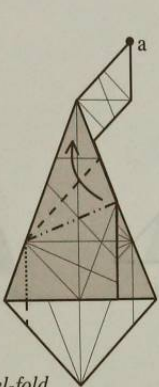

22. Swivel-fold.



23. Partially open.

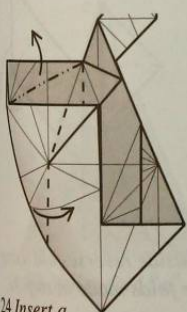

24. Insert a
swivel-fold whilst
closing the model.



25. Valley-fold.



26. Rabbit-ear fold.

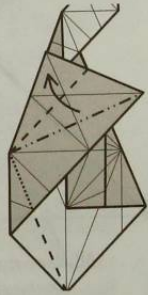

27. Swivel-fold.

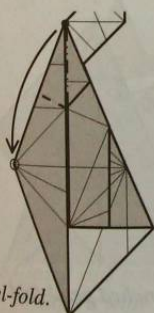

28. Swivel-fold.

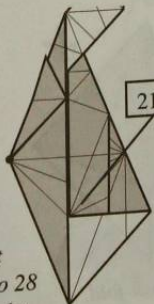

29. Repeat
steps 21 to 28
on the right.



30. Fold the
top flaps down.

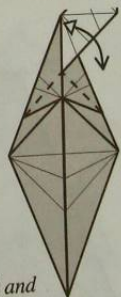

31. Fold and
unfold the top layer.
Repeat on the right.

Folding the Goblin's Head :

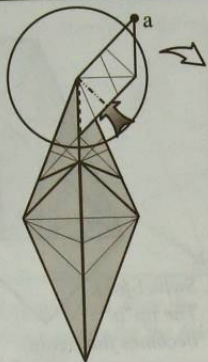

32. Squash-fold.
Focus on the head.

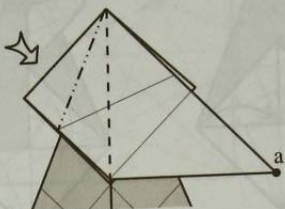

33. Squash-fold.

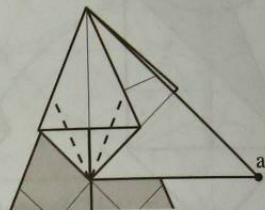

34. Fold along angle bisectors
then unfold.

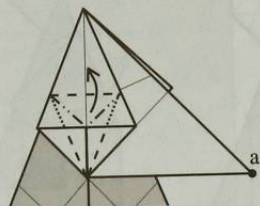

35. Petal-fold.

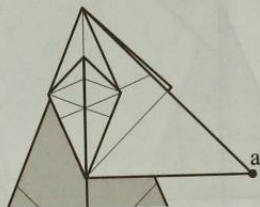

36. Unfold to step 33.

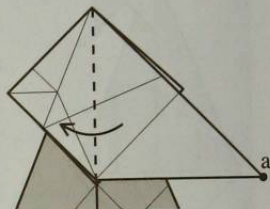

37. Valley-fold the flap to
the left.

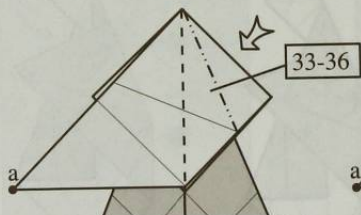

38. Repeat steps 33 to 36
on the right.

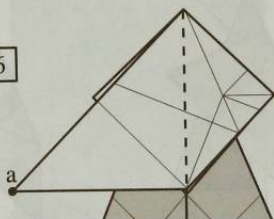

39. Unfold to step 32.

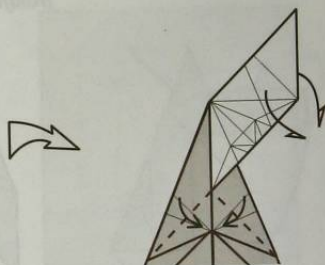

40. Outside reverse-fold using
the folds made in step 31.

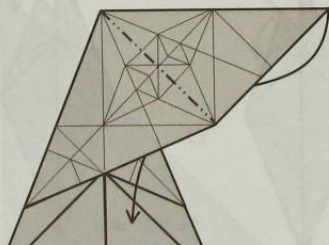

41. Reverse-fold.

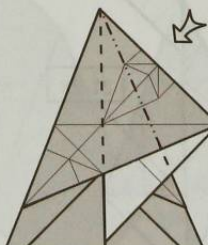

42. Squash-fold.

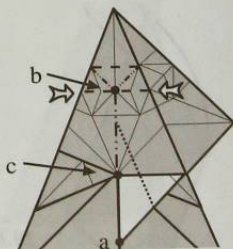

43. Pinched petal-fold.

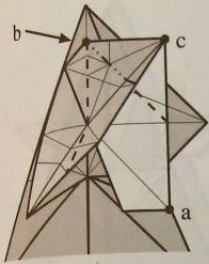

44. The model is not flat.
Squash-fold.

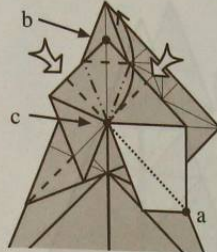

45. Continue to fold the bird-base by lifting "c" upwards.

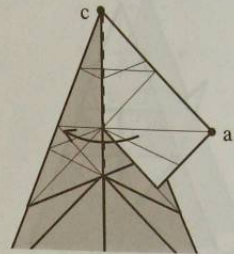

46. Valley-fold the flaps to the left.

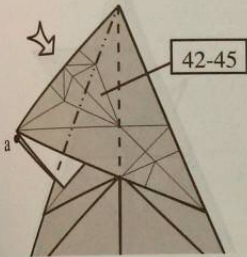

47. Repeat steps 42 to 45 on the right.

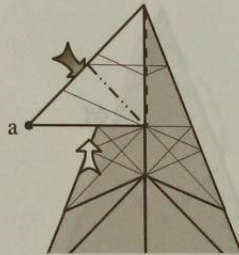

48. Squash-fold symmetrically.

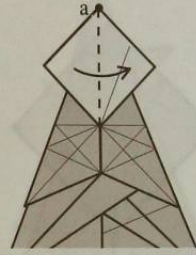

49. Valley-fold to the right.

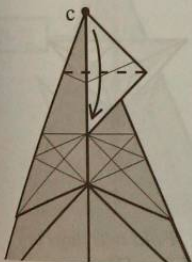

50. Valley-fold "c".

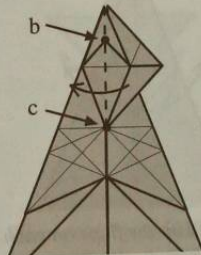

51. Valley-fold to the left.

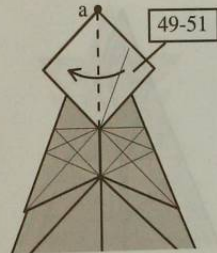

52. Repeat steps 49 to 51 on the right, then pull point "a" towards you a bit.

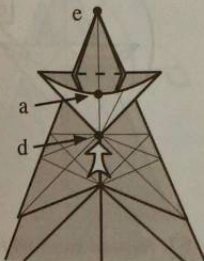

53. Closed sink point "d" to align it with "e".

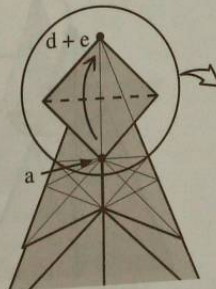

54. Valley-fold flap "a".

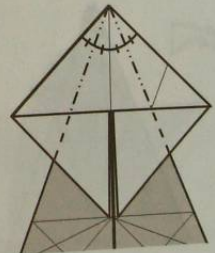

55. Reverse-folds.

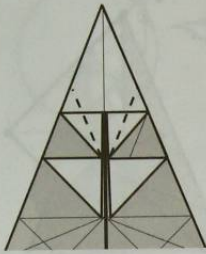

56. Fold along angle bisectors then unfold.

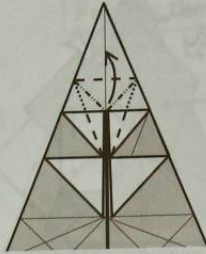

57. Petal-fold.

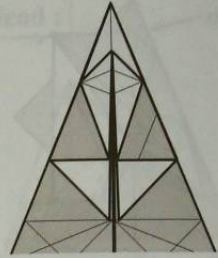

58. Unfold to step 54.

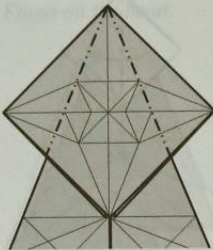

59. Reverse-folds.

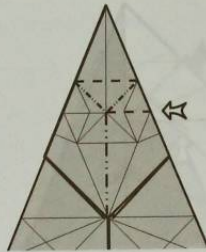

60. Pinched petal-fold.

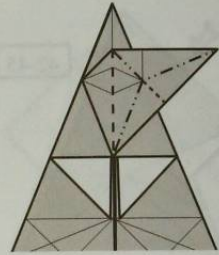

61. Finish the bird-base.

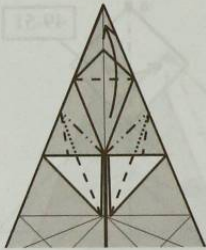

62. Valley-fold the front flap.

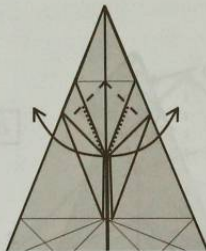

63. Fold up the flaps on each side, and create squash folds on the bottom halves.

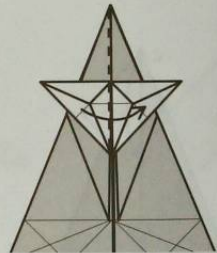

64. Fold two flaps to the right.

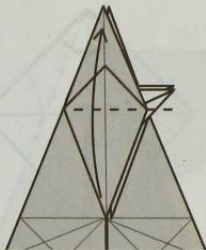

65. Valley-fold the flap.

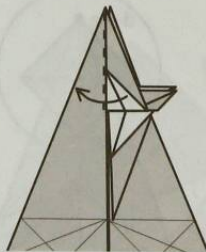

66. Valley-fold the flaps to the left.

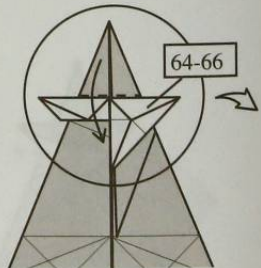

67. Repeat steps 64 to 66 on the right. Then fold the front flap down.

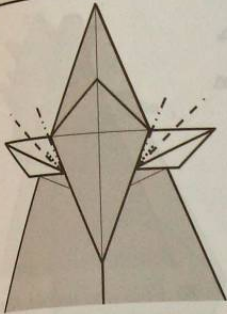

68. Pleat-fold. Valley-fold (hidden) behind the flaps through all layers.

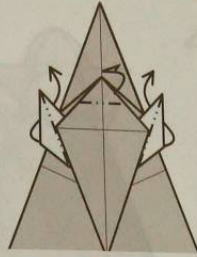

69. Note that the teeth are between the two layers of the front flap. Narrow teeth with a reverse-fold (fold through all layers).

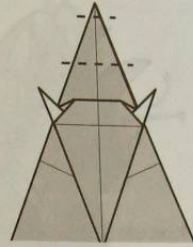

70. Make the nose with two valley-folds.

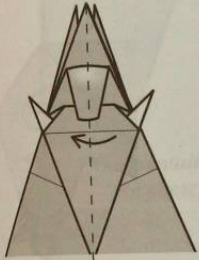

71. Valley-fold very lightly to free the ear (be careful to not damage the face)

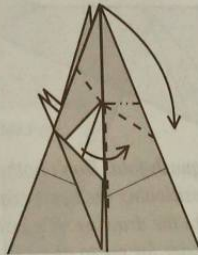

72. Swivel-fold the ear.

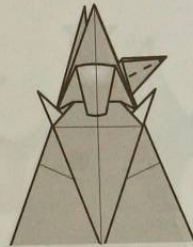

73. Valley-fold the front layer down to hide the central mark.

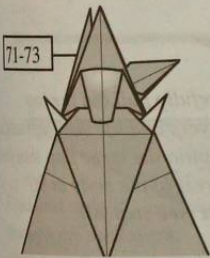

74. Repeat steps 71 to 73 on the left ear.

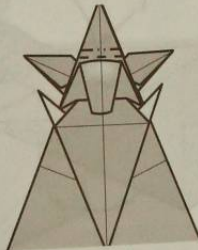

75. Pleat-fold through all layers. Crease firmly, unfold and turn over.

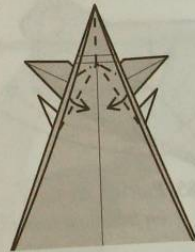

76. Fold the front layers to the centre.

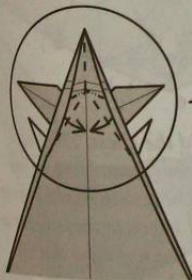

76. Focus on the folding sequence.

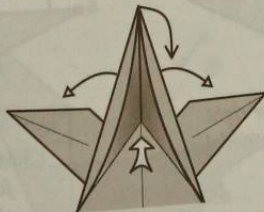

77. Pull out the centre flaps to open the head and create a 3D effect. The top of the head tips down and back, and the front flaps are flattened into the model.

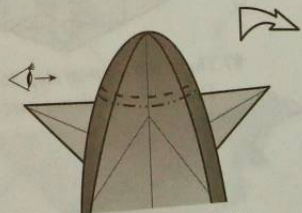

78. The result. Pleat-fold to shape the eyes, following the creases from step 75.



79. 3D view of the head.

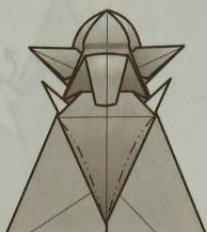

80. Shape the head as you want.

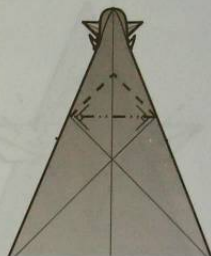

81. Fold and unfold. Note that the creases at 45° are only on the top layer.

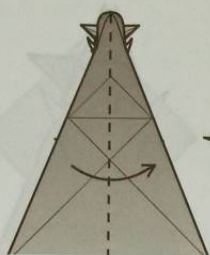

82. Valley-fold the model in half.

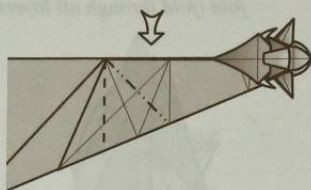

83. Squash-fold. Don't bother positioning the head exactly like the drawing. It's just easier for me to draw it like that ...



84. Open up all the layers. Flatten using the creases made in step 81.

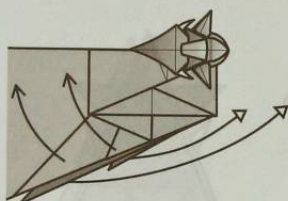

85. Pull out the flaps on front and behind.

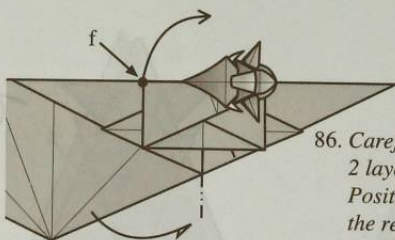

86. Carefully pull out the top 2 layers and lift them upwards. Position the large flap that forms the rest of the body at 90° to the head (see step 90).

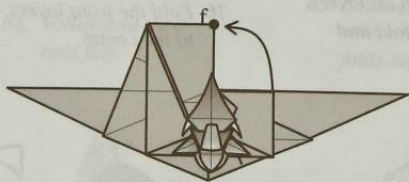

87. The result. Repeat step 86 on the right. This step only shows part of the model.

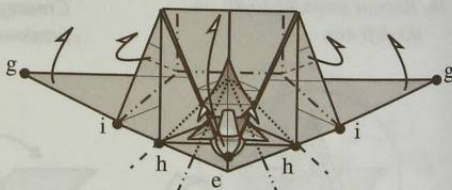

88. Mountain-fold the chest. The head follows the movement. Narrow the tips and the chest with partial reverse-folds. Partial because these reverse-folds are not flat to follow the 90° angle. That's why the arms "g" can't stay in their initial position and must be swivel-folded to lie along the body.

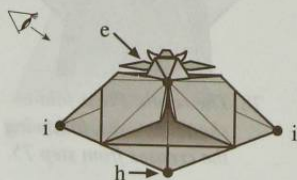

89. The model is in 3D. Check your folding with the next step.

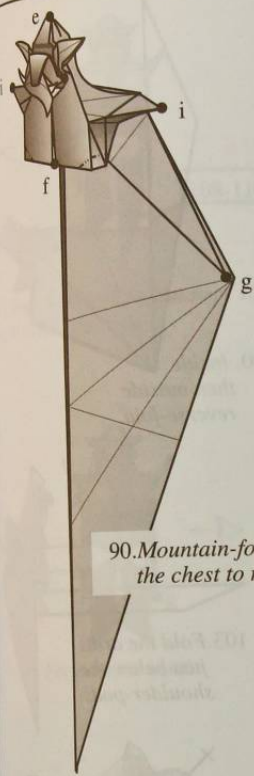

90. Mountain-fold the corners of the chest to round it.

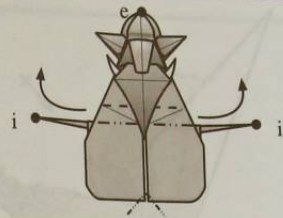
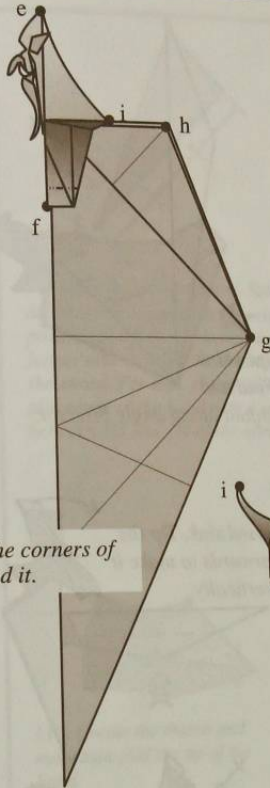

91. Pleat-fold to shape the neck and emphasise the chest. Round the shoulder-pads. The bottom part of the model isn't shown here.



92. The Goblin's bust is finished

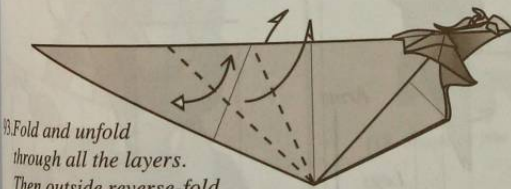

93. Fold and unfold through all the layers. Then outside reverse-fold

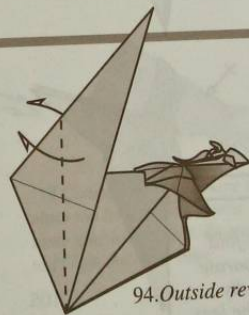

94. Outside reverse-fold

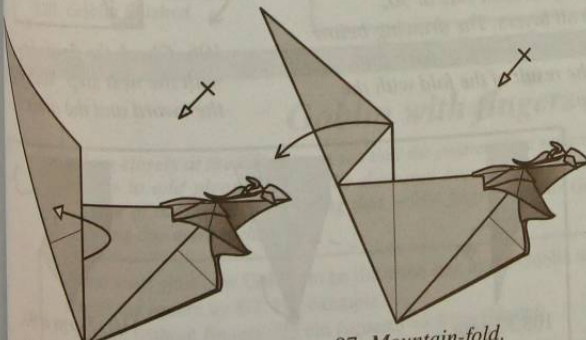

96. Pull out the flap. Repeat behind.

97. Mountain-fold. Repeat behind.

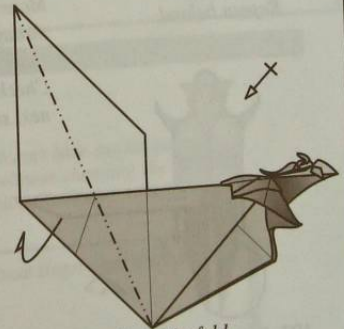

97. Mountain-fold. Repeat behind.

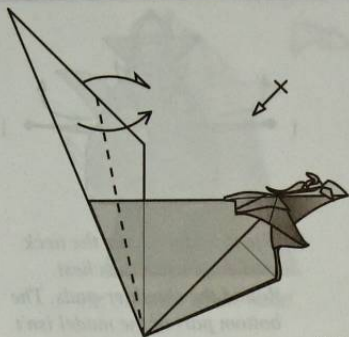

98. Outside reverse-fold.

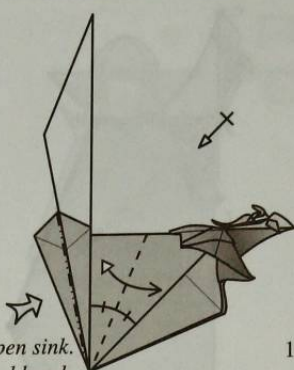

99. Open sink. Fold and unfold along angle bisector.

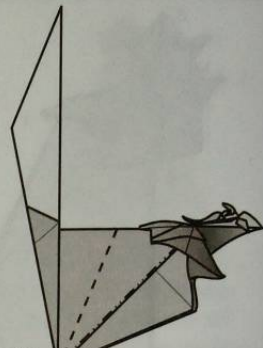

100. Inside then outside reverse-fold.

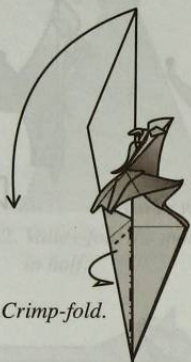

101. Crimp-fold.

102. Closed sink. Tip the head forwards to make it stand vertically.

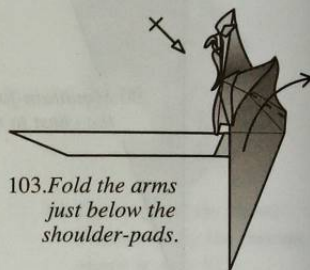
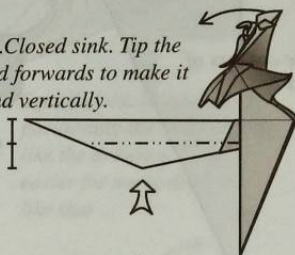

103. Fold the arms just below the shoulder-pads.

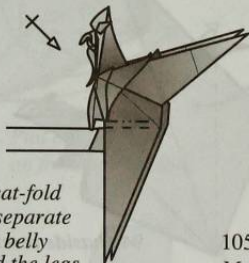

104. Pleat-fold to separate the belly and the legs. Repeat behind.

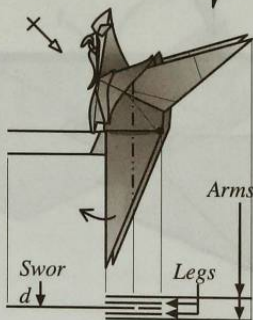

105. Mountain-fold each side at 90 through all layers. The drawing below shows a cross-section of each part. Check the result of the fold with the next step.

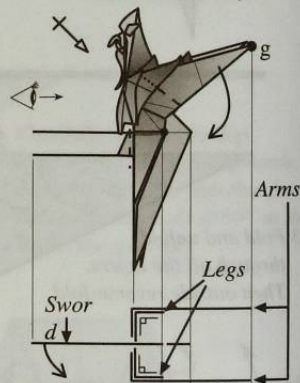

106. Check the final view with the next step. Valley-fold the sword and the arms.

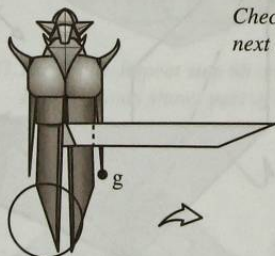

107. Valley-fold the sword as shown.

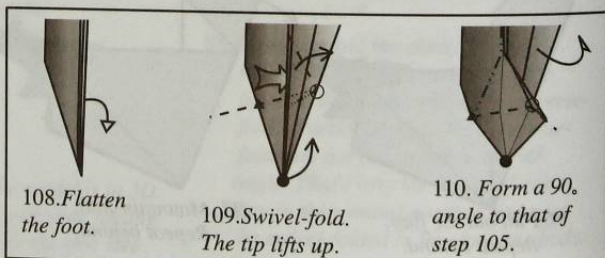

108. Flatten the foot.

109. Swivel-fold. The tip lifts up.

110. Form a 90 degree angle to that of step 105.

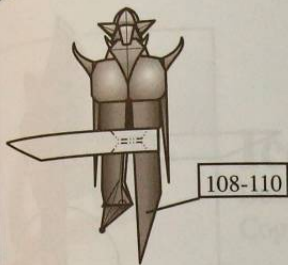

111. Shape the sword. Repeat steps 108 to 110 on the other foot.

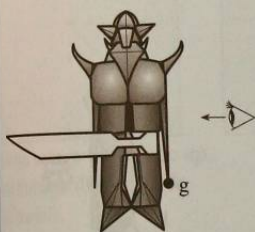

112. Focus on the hand.



120. Goblin finished.

113. Only the arm is shown. Squash-fold at 1/3. Depending upon the original position of the arm, you may need a longer arm to position the hand well on the sword. For that, change the placement of the hand with a squash-fold between 1/3 and 1/4 of the arm.

114. Open each side.

115. Open the hand to make it 3D.

116. Create the thumb and mountain-fold the tip of the hand

117. Pleat-folds to create the fingers.

118. Shape as you want.

119. Completed hand. Shape the arm to place the hand on the sword. I often use some glue to secure it. Repeat steps 113 to 117 on the other arm.

Goblin with fingers

Looking closely at the CP, we can see that the centre of the square doesn't have any key points. So it's easy to add pleat-folds on the diagonal between the arms without changing the folding sequence of the model. Now, using that, add 4 fingers to your Goblin. Challenge : add 5 fingers by adding one more pleat.

If you want your new Goblin to be the same size as the Goblin without fingers, just multiply the size of the square by 8/7. For example :

- Goblin without fingers : 25 cm (square) => 8 cm (Model)

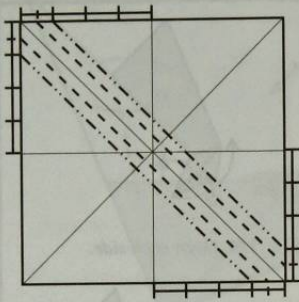

a. Pleat-fold.

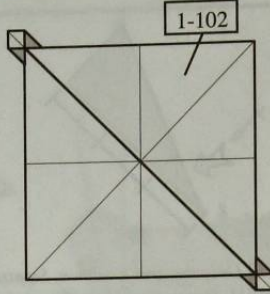

b. Continue with steps 1 to 102 of the Goblin.

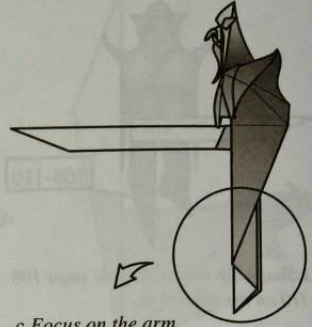

c. Focus on the arm.

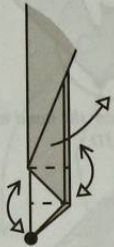

d. Fold and unfold. Then partially open the arm.

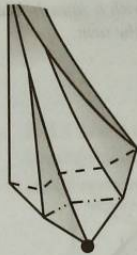

e. Pleat-fold following the creases made in step d.

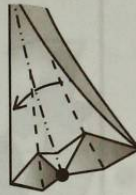

f. Close the flaps.

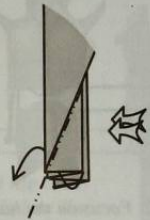

g. Reverse-fold both flaps.



h. Reverse-fold both flaps.



i. Reverse-fold both flaps.



j. Partially unfold the arm.



k. Partially unfold the flap.

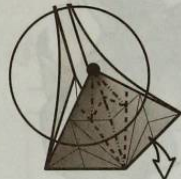

l. Fold the tip * up at 90° by using the 45° valley folds.

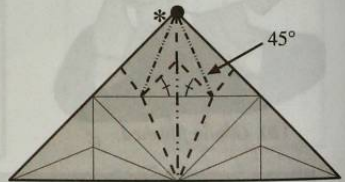

m. Close the flap using the reverse-folds of steps g to i.



n. The thumb is now at 90° to the 3 other fingers.

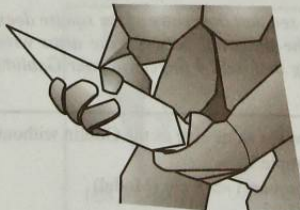

o. Repeat steps d to n on the other arm. Then complete the model following steps 103 to 111 of the Goblin. Place the fingers around the sword to make their presence more obvious.



Iconic Motorcycle

Designed by Xander D. Arena
Copyright ©2003. All Rights Reserved.

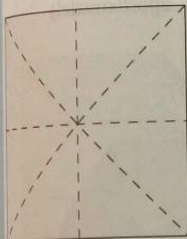

1. With square white side up, fold through diagonals & horizontals.

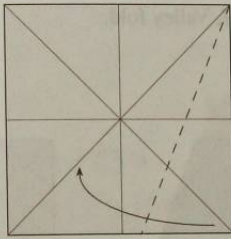

2. Kite crease.

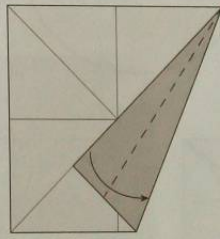

3. Kite crease.

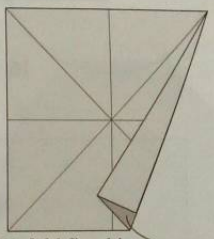

4. Unfold first kite.

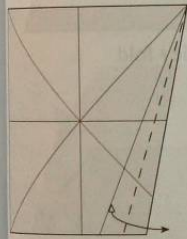

5. Bring folded edge to crease, then unfold to square.

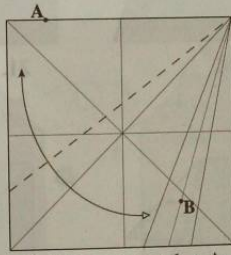

6. Kite crease edge A to line B, then unfold.

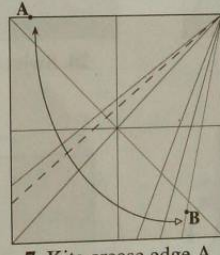

7. Kite crease edge A to line B, then unfold.

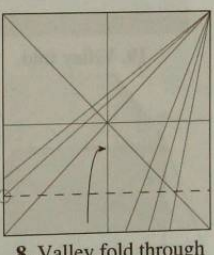

8. Valley fold through CI, (crease intersection).

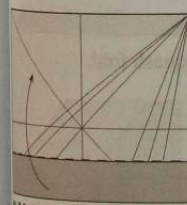

9. Valley fold through the raw edge.

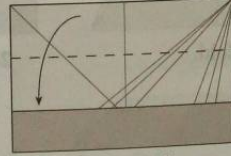

10. Valley fold the raw edge to the folded edge.

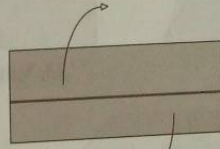

11. Unfold to step 9.

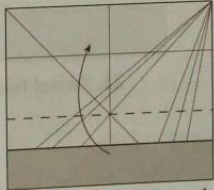

12. Valley fold through midline.

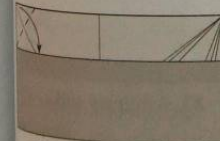

13. Valley fold.

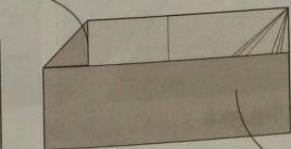

14. Unfold to square.

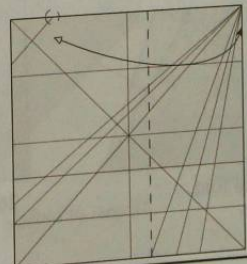

15. Valley fold vertically to CI, then unfold.

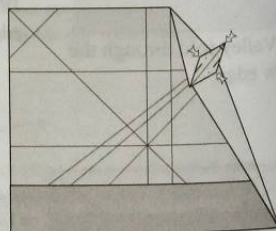
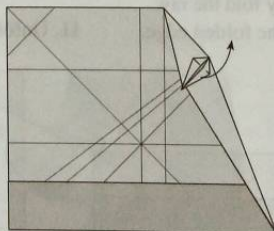
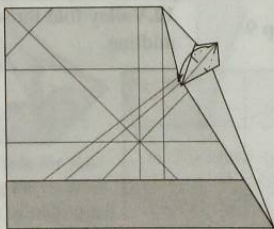
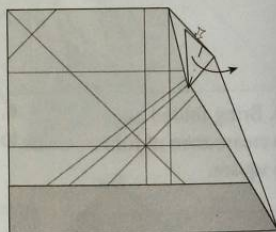
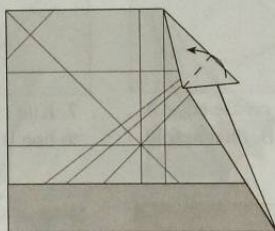
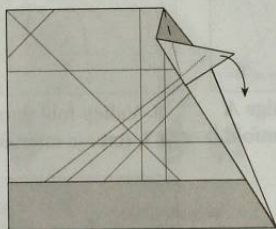
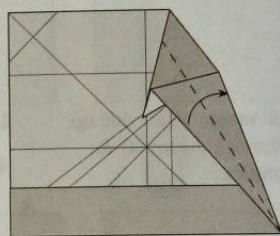
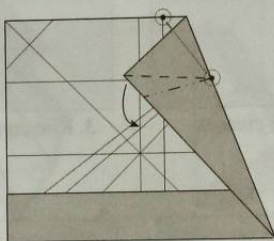
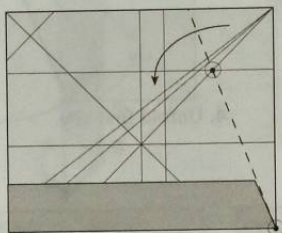
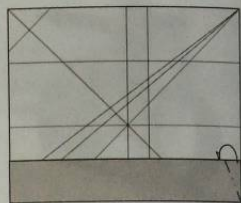
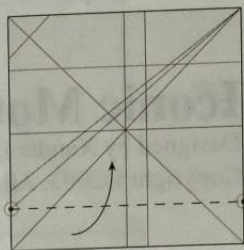
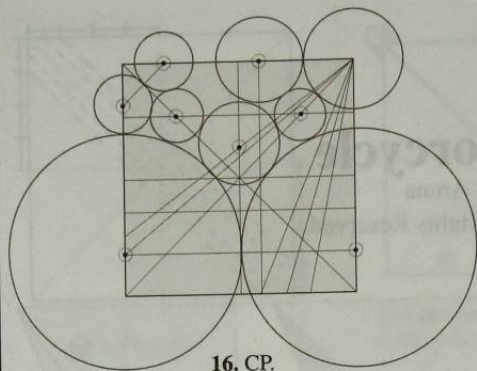

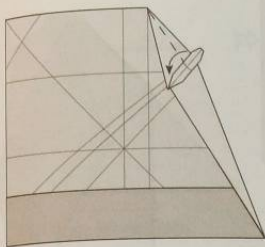

28. Valley fold, incorporating a small reverse fold.

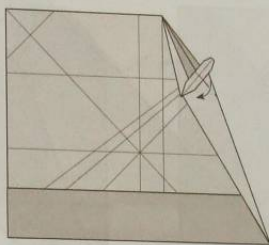

29. Arbitrary valley fold, incorporating reverse at base.

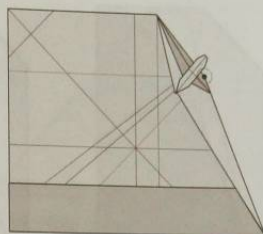

30. Note CP's reference point.

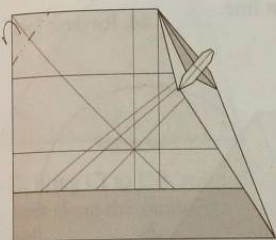

31. Fold behind and turn model over.

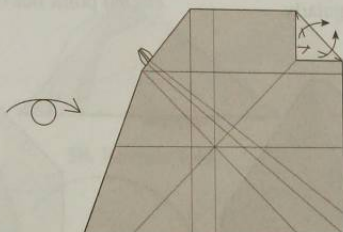

32. Rabbit ear.

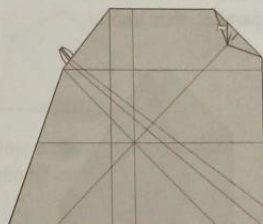

33. Squash fold small flap.

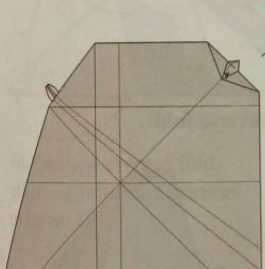

34. Valley fold small triangle, then turn model over.

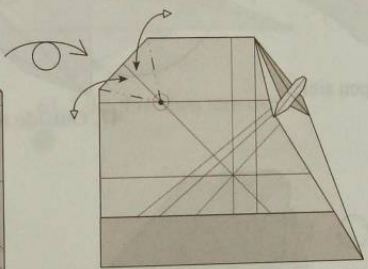

35. Make mountains, then unfold.

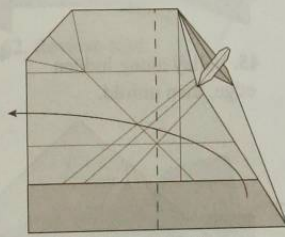

36. Valley in half.

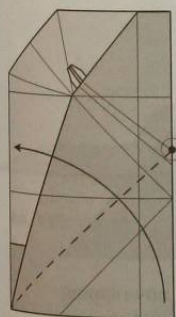

37. Valley fold through all layers.

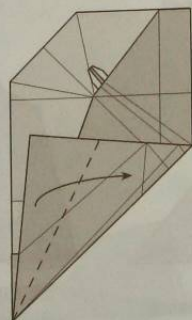

38. Valley fold top layer.

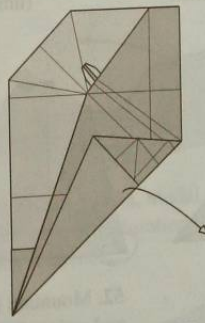

39. Unfold to step 37.

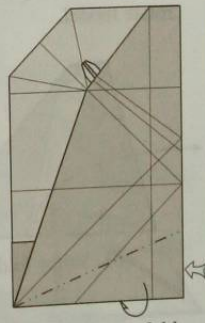

40. Reverse fold.

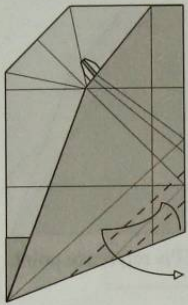

41. Crease into thirds, parallel, then unfold.

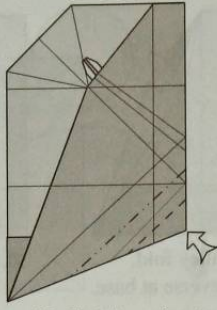

42. Sink in and out triangularly.

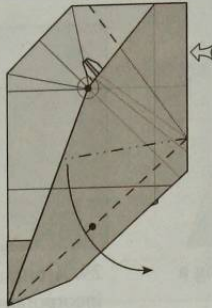

43. Squash fold, so that circled point lies on line.

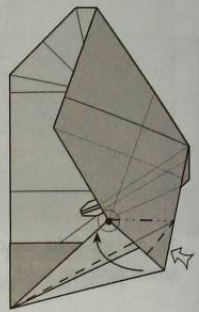

44. Reverse fold.

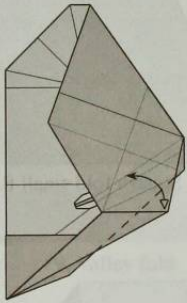

45. Valley along hidden edge, then unfold.

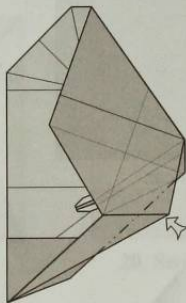

46. Open sink.

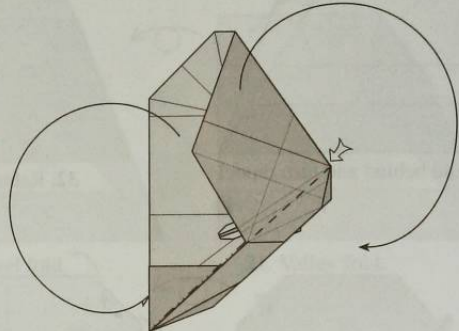

47. Outside reverse fold.

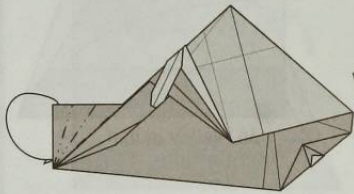

48. Mountain fold over into thirds, then into pocket, then rotate model.

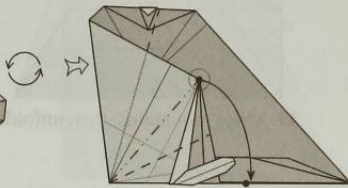

49. Swivel fold corner to UB, (uniaxial base).

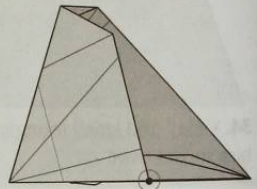

50. Like this.

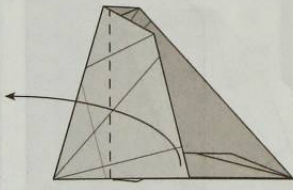

51. Valley fold.

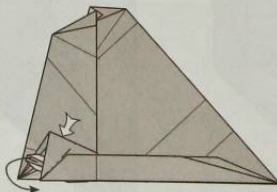

52. Mountain fold exhaust, and swing down while reverse folding.

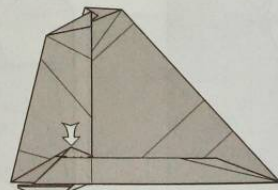

53. Open sink, unwrapping slightly to accomplish.

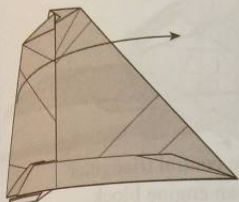

54. Close large flap.

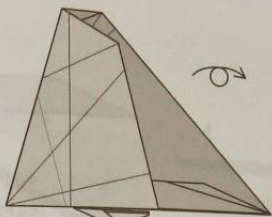

55. Turn model over.

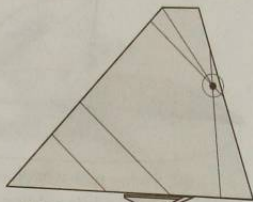

56. Note crease intersection.

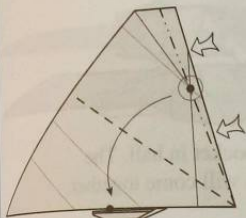

57. Bring CI to UB, rolling paper along the mountain fold.

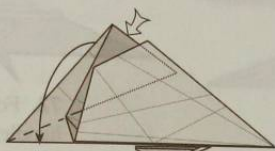

58. Reverse fold.

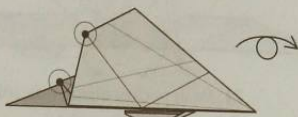

59. Note reference corners, then turn model over.

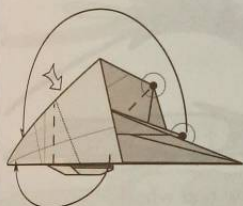

60. Outside reverse fold, allowing reference corners to lie on UB.

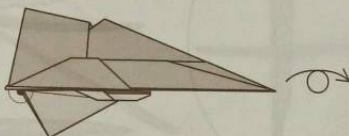

61. Like this, then turn over.

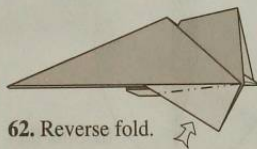

62. Reverse fold.



63. Reverse fold again.

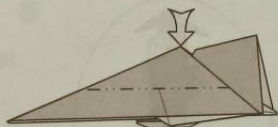

64. Sink triangular region to align with horizontal layers. A crimp will form in the interior.

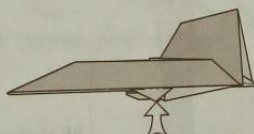

65. Sink upward into model.

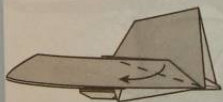

66. Valley fold.

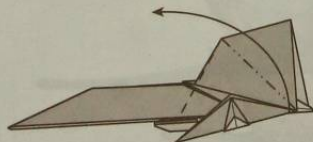

67. Open out pocket, model will not lie flat for the duration of the folding sequence.

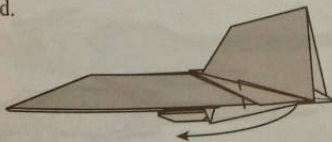

68. Valley fold.

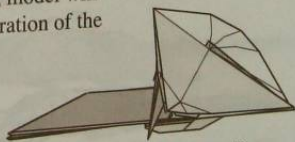

68. Like this.

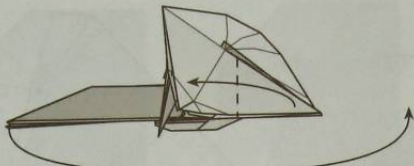

69. Swing rear wheel assembly to the right, while folding triangular interior to the left.

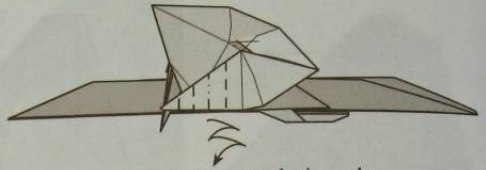

70. Pleat the central triangular region into an engine block.

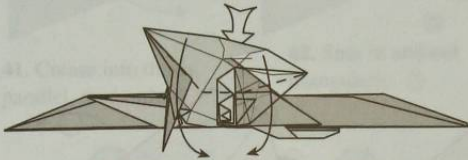

71. Push pocket inside out, folding along indicated creases.



72. Fold pocket in half. The handlebars will come together.

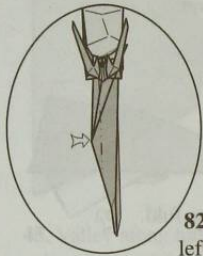

82. Sink the left side.

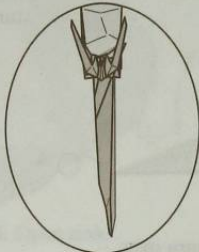

83. Like this.

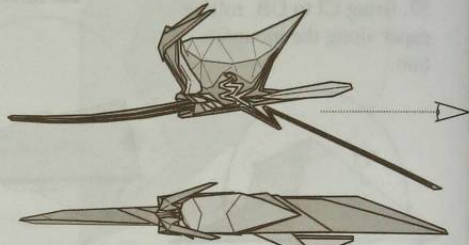

84. View rear wheel.

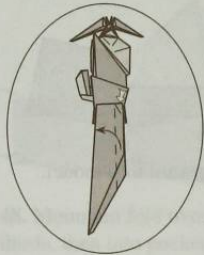

85. Valley fold, with a squash at the top.

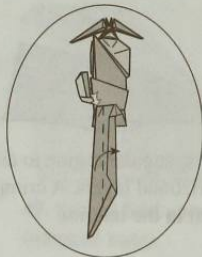

86. Valley fold, with a squash at the top.

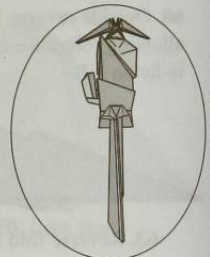

87. Like this.

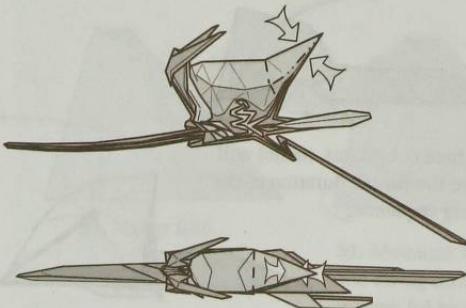

88. Compress seat.

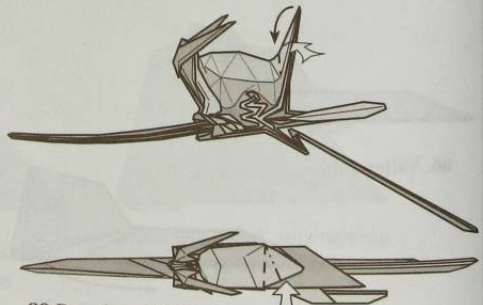

89. Popping middle ridge, begin squash folding seat...

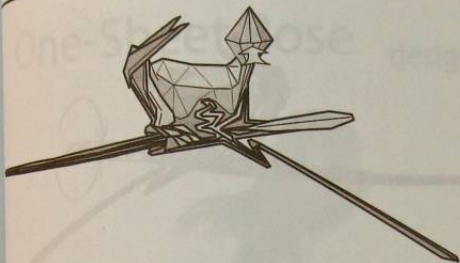

90. ...in progress...

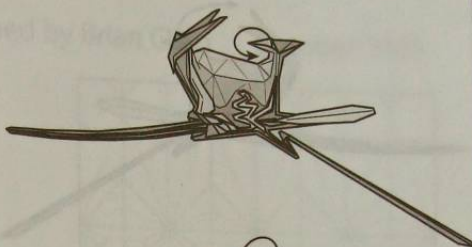

91. Wrap lighter portion of seat behind.



92. Mountain fold corner of seat.

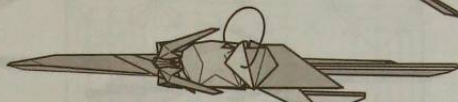

93. Outside crimp handgrips.

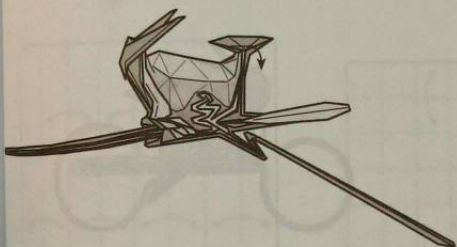

94. Fold top of seat backward.

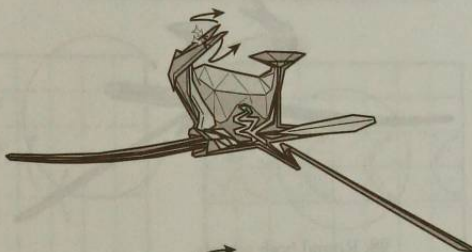

95. Mountain fold edge of tank underneath.

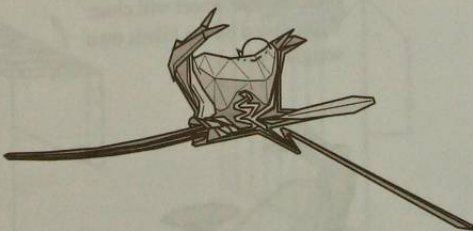
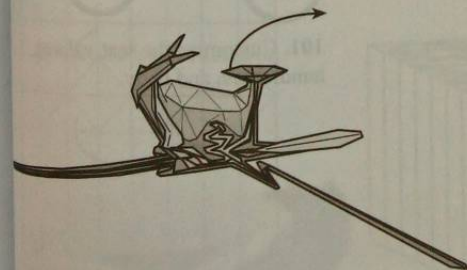
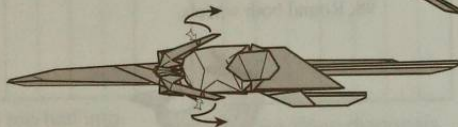
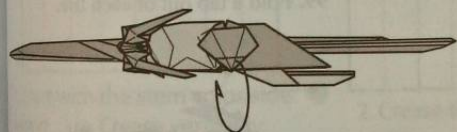

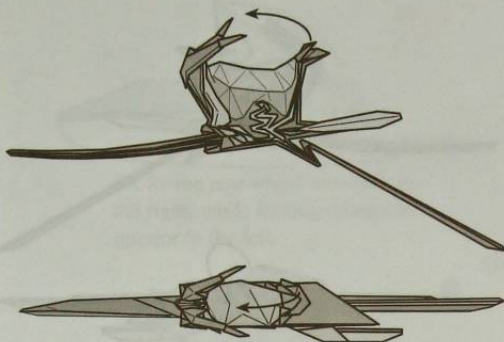

96. Swing seat back into position.

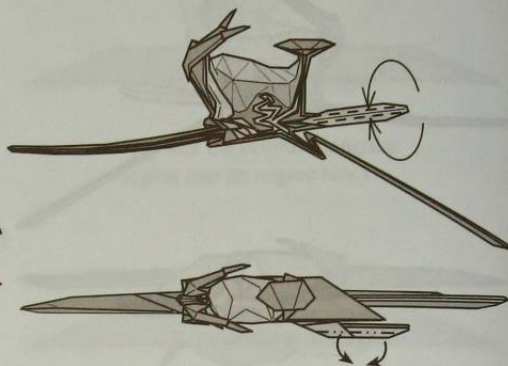

97. Roll exhaust into a cylinder.

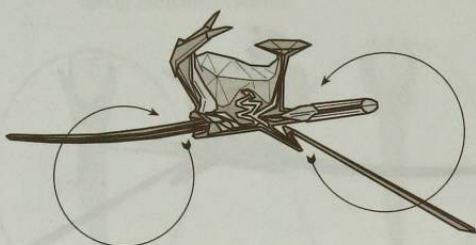

98. Round both wheels.



99. Fold a tab out of each tire.

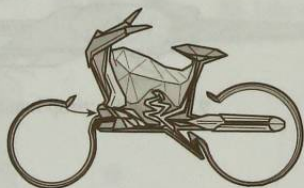

100. Tuck the front tire into the bike, the rear wheel will close when rested on the bike's own weight.



101. Customize the seat, exhaust, handlebars, and body.

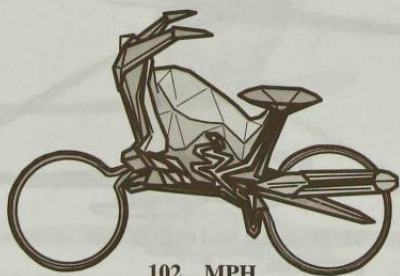

102... MPH

XANDER



www.xanderfolds.com

One-Sheet Rose

designed by Brian Chan October 2005

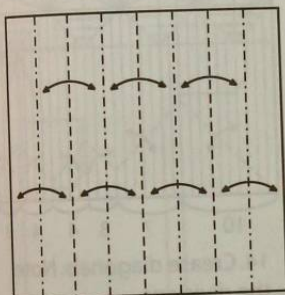
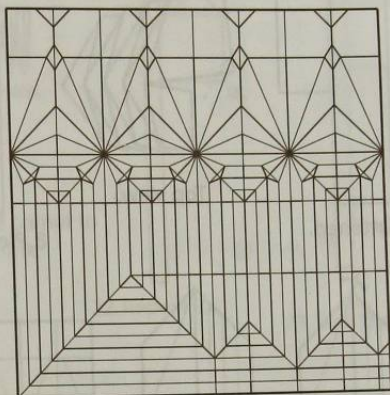

1. Start with the stem color side facing up. Crease vertically into eighths

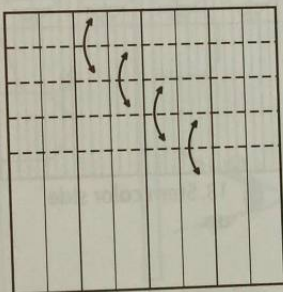

2. Crease the top half into eighths.

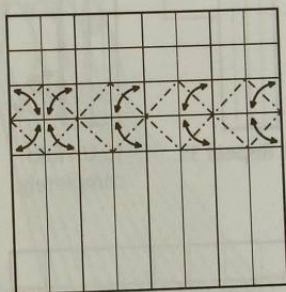

3. Crease along diagonals.

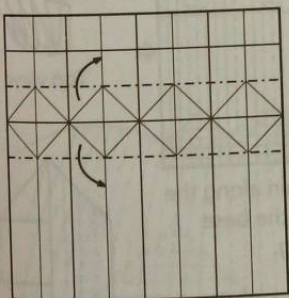

4. Fold the top fourth and the bottom half down, partially.

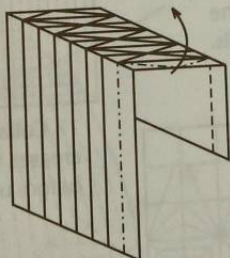

5. Petal fold.

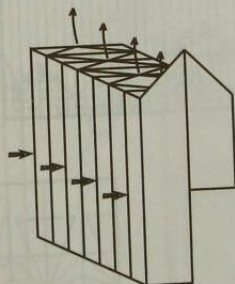

6. Continue folding in along the sides and forming points on the top.

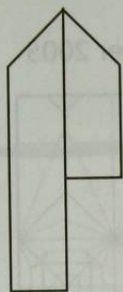

7. Flattened.

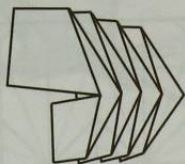

Top view.

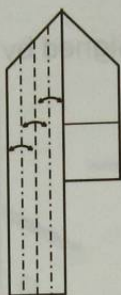

8. Pleat into fourths.

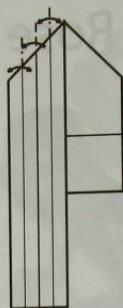

9. Repeat 3x.

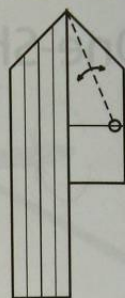

10. Crease the angle bisector.

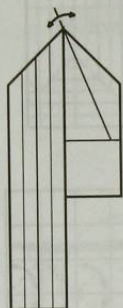

11. Repeat 3x.

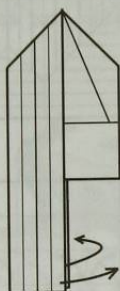

12. Un fold completely.

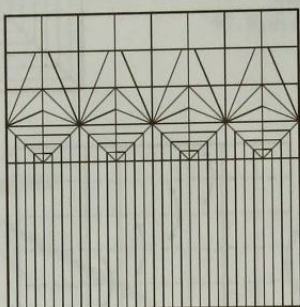

13. Stem color side up.

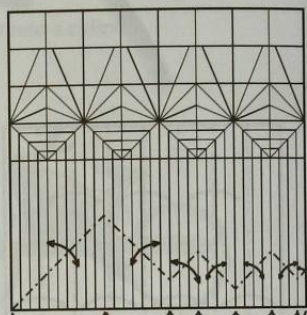

14. Crease diagonals. Note the divisions.

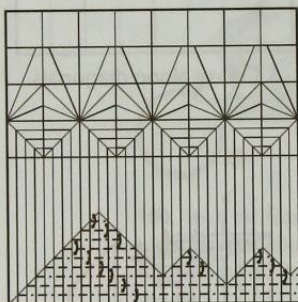

15. Crease 32nds horizontally below the diagonals.

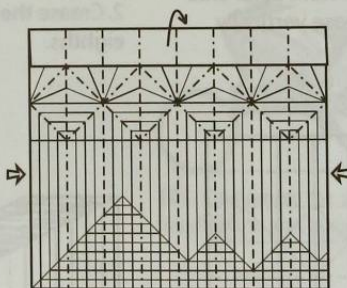

17. Collapse again along the creases to form the base before unfolding.

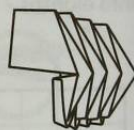

Top view.

16. Valley-fold down the top 1/8.

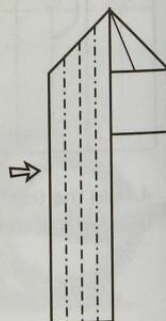
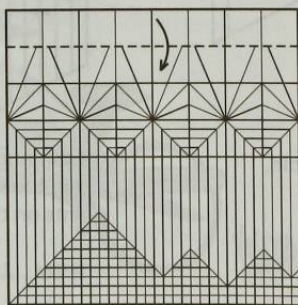

18. Open sink.

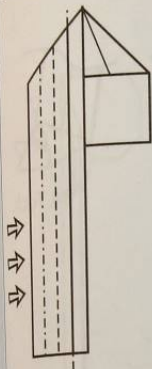

19. Repeat 3x

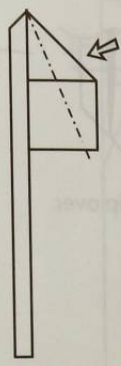

20. Open sink

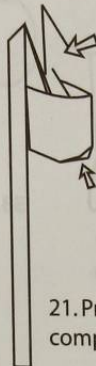

21. Press in the corner to complete the sink.



Top view.

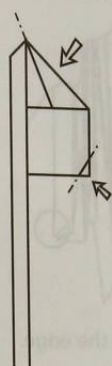

22. Repeat 3x

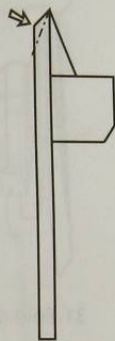

23. Sink the tip

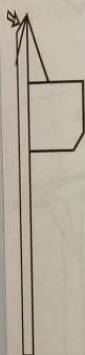

24. Repeat 3x

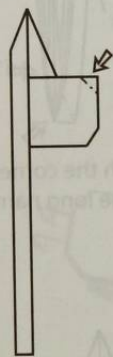

25. Reverse fold.

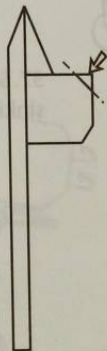

26. Repeat 3x.



27. Change view

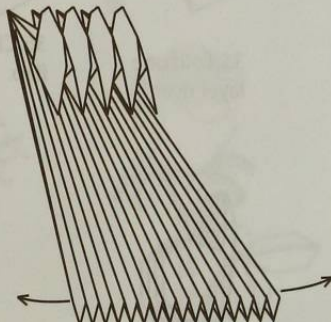

28. Fan out the bottom edge.

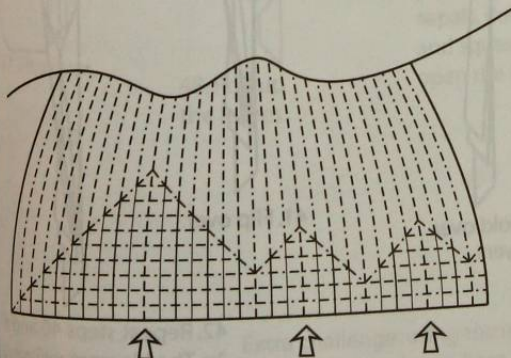

29. Collapse along the creases shown. (Elias stretch)

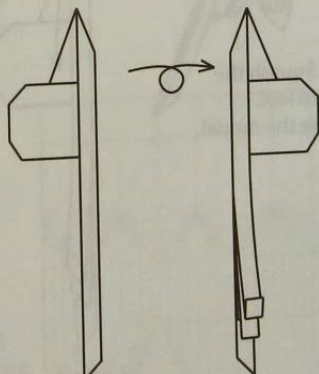

30. Flip over.

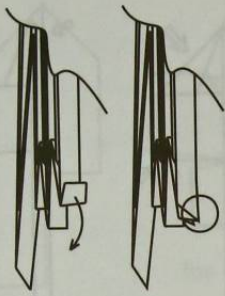

31. Fold down the edge.

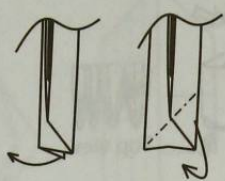

32. Open the layer behind, mountain fold.

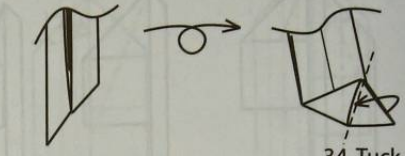

33. Flip over.

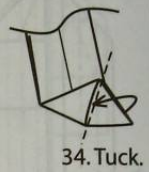

34. Tuck.



35. Fold one layer over.



36. Close the flap.



37. Squash the corner while sinking the long narrow flap.

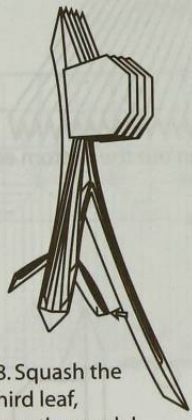

38. Squash the third leaf, close the model.

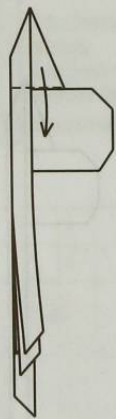

39. Fold down.

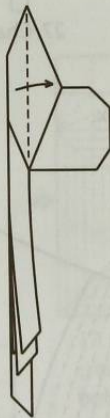

40. Fold over 2 layers

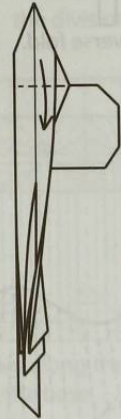

41. Flip over.



42. Repeat steps 40 and 41 3x. The blossom will rotate up by itself.

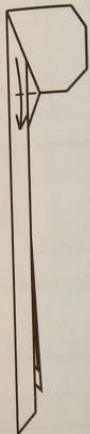

43. Fold down the last flap.

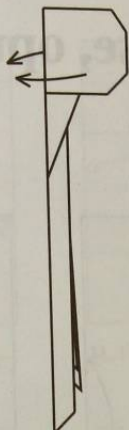

44. Outsidee-reverse fold.

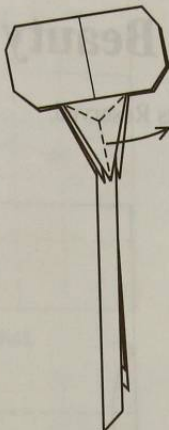

45. Rabbit ear.

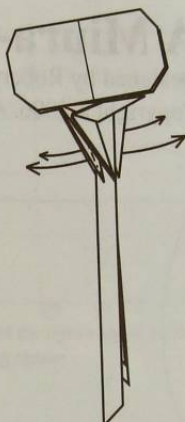

46. Rabbit ears.

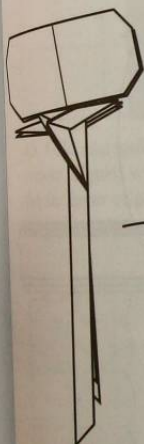

47. Flip over.

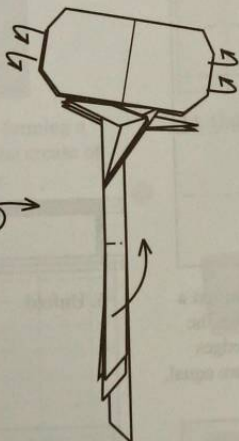

48. Roll up the leaves.



49. Curl the petals, pinch and curl the sepals. Roll the stem and squash fold open the leaves.

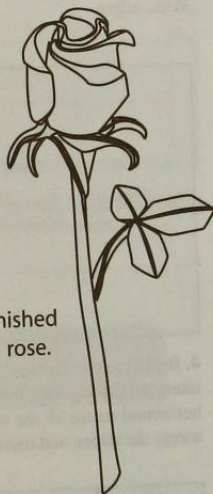

50. Finished rose.

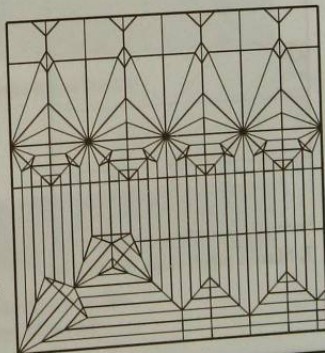

Extra challenge: using the modified crease pattern shown here, fold a rose with thorns.

A Miura-ken Beauty Rose, opus 482

Designed by Robert J. Lang

Copyright ©2006. All Rights Reserved.

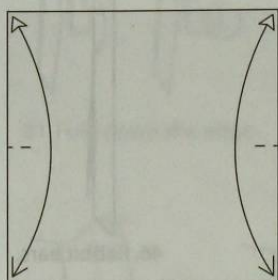

1. Begin with square, white up. Fold and unfold in half, pinching at the edges.

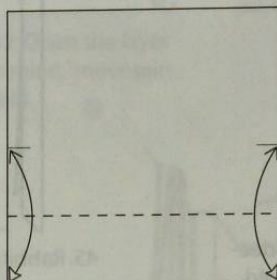

2. Fold and unfold.

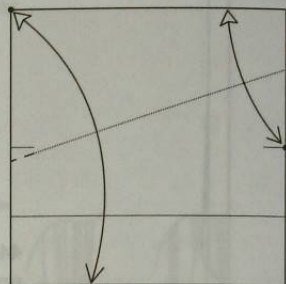

3. Bring the top left corner to the bottom edge and the top edge to the crease intersection along the right; pinch at the left edge and unfold.

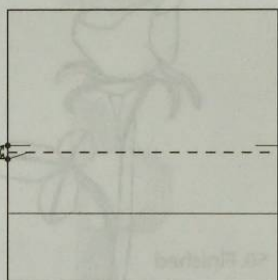

4. Bring the two crease intersections together, forming a horizontal crease all the way across the paper, and unfold.

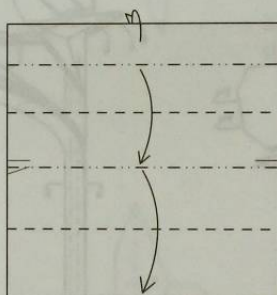

5. Using the first two creases as a guide, pleat the paper so that the distances between folded edges along the top and bottom are equal.

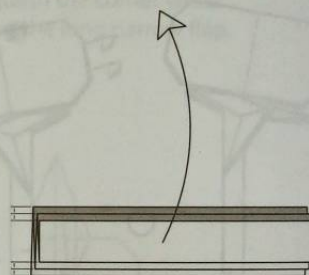

6. Unfold.

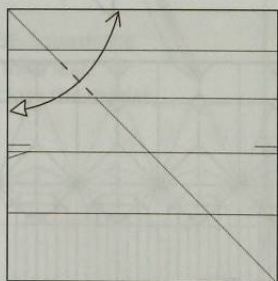

7. Make a pinch along the diagonal.

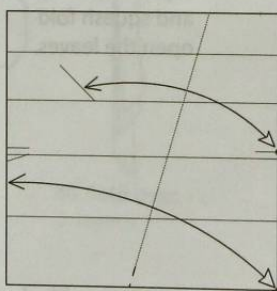

8. Bring two points along the right edge to the left edge and the diagonal pinch, making a new pinch along the bottom edge.

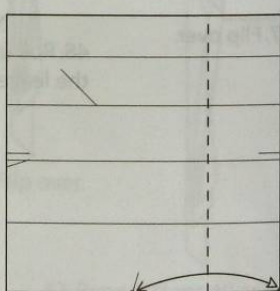

9. Bring the two points together, forming a vertical crease from bottom to top, and unfold.

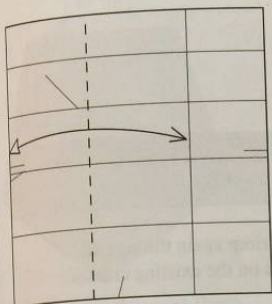

10. Fold and unfold.

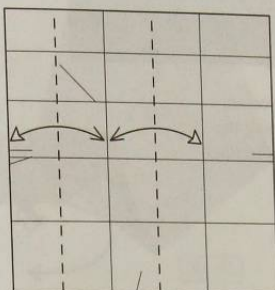

11. Fold and unfold.

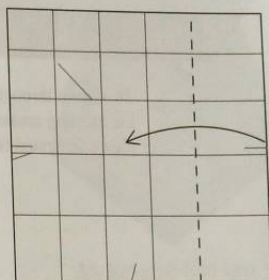

12. Fold the right edge in on the existing crease.

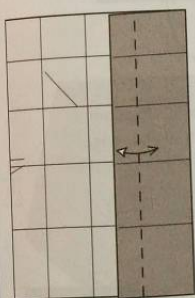

13. Fold and unfold, forming a crease aligned with the crease on the far layer of paper.

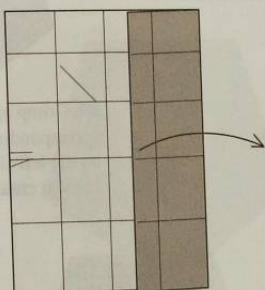

14. Unfold.

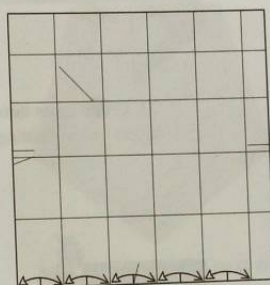

15. Divide each full panel in half along the bottom edge.

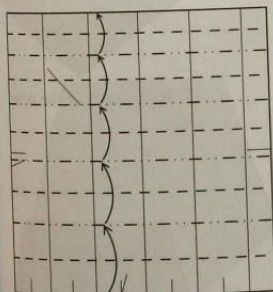

16. Pleat, making the mountain folds on existing creases and the valley folds so that all folds are aligned along the top edge.

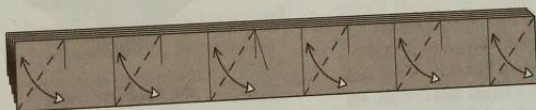

17. Crease through all layers.



18. Turn over from top to bottom.

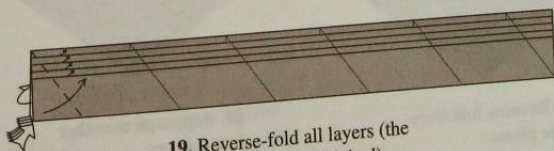

19. Reverse-fold all layers (the reverse folds are all linked).

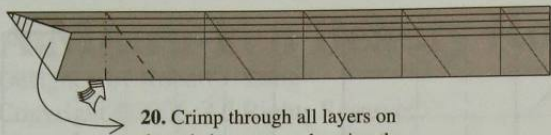

20. Crimp through all layers on the existing creases, keeping the pleats separated from one another.

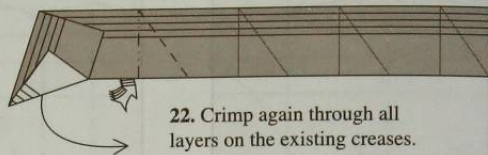

22. Crimp again through all layers on the existing creases.

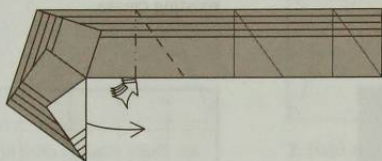

23. Crimp again through all layers on the existing creases.

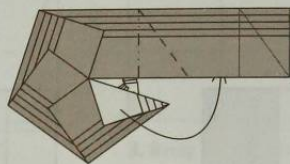

24. Crimp again, tucking each corner into a corresponding pocket. Note that raw edges on the left side should exactly line up with vertical creases on the right.

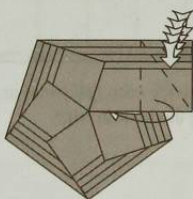

25. Reverse-fold 5 edges, wrapping the paper over the coiled-up left side. Make sure the raw edges and creases are aligned and flatten completely.

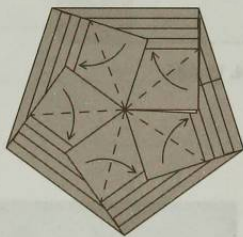

26. Fold five flaps counterclockwise.

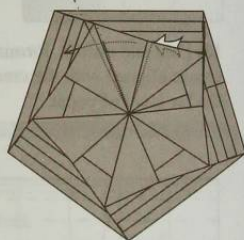

27. Reverse-fold the near pleat.

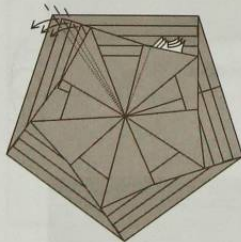

28. Reverse-fold three more pleats.

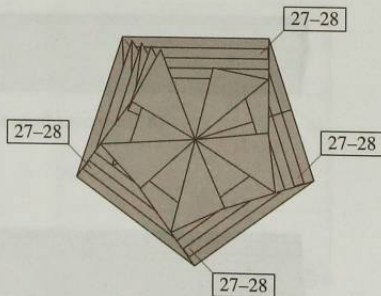

29. Repeat on the other four corners.

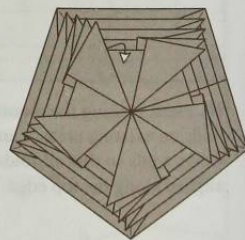

30. Pull the excess paper out of the pocket as far as possible. The result will not lie flat.

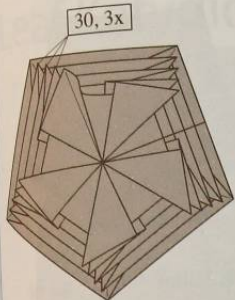

31. Repeat on the next three corners. Again, the result will not lie flat (nor will it for the remainder of the model).

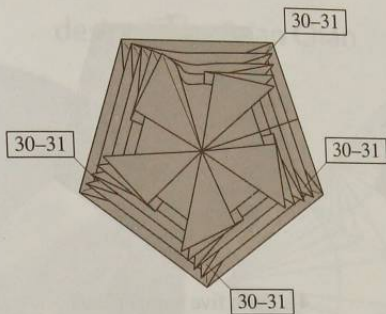

32. Repeat on the other four corners.

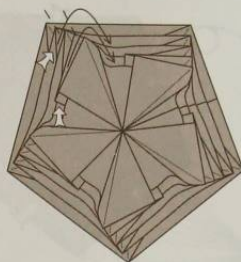

33. Reverse-fold two edges.

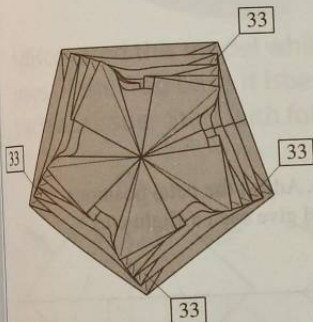

34. Repeat on the other four corners.

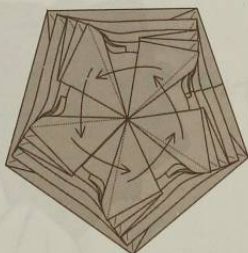

35. Lift and curl the innermost flaps around each other, forming a tight, upright cone. Each corner in the cone should be locally flat with 3 layers pointing clockwise and 1 counterclockwise; see the next step for details.

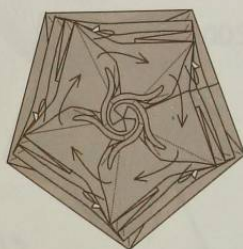

36. Lift and curl the next ring of corners into a looser cone; in this ring, each corner should have 3 layers pointing counterclockwise and one pointing clockwise, and the petals should be positioned in the gaps between the petals of the innermost ring.



37. Lift and curl the next ring of corners into a still looser cone; in this ring, each corner should have 3 layers pointing clockwise and one pointing counterclockwise and again, the petals should be positioned in the gaps between the petals of the previous ring.

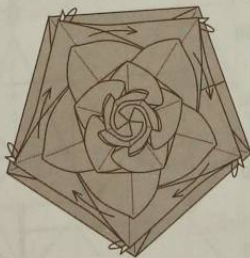

38. Lift and curl the next ring of corners into a very shallow cone as before.

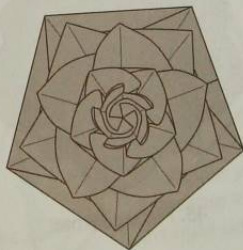

39. Turn the model over.

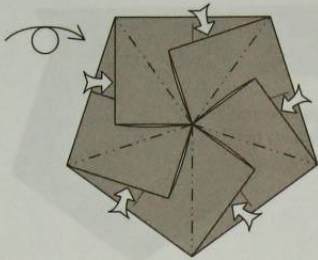

40. Reverse-fold the five corners into the interior of the model.

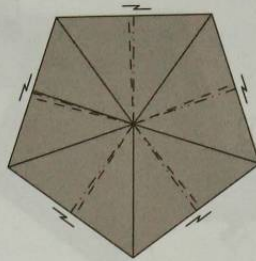

41. Form five narrow pleats. the paper becomes slightly conical with the edges pointing away from you.

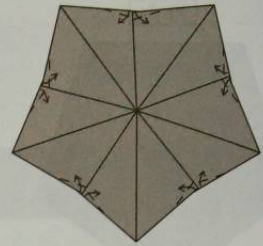

42. Valley-fold the top of each pleat, squash-folding at the end of the pleat. This locks the pleat into place.

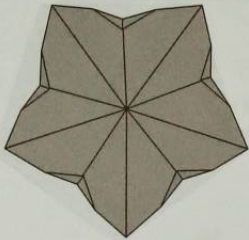

43. Turn the model over and rotationally adjust the petal positions so that each ring of petals lies in the gaps between the petals of the adjacent rings.

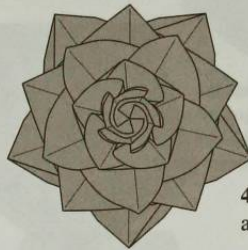

44. Adjust the petal positions and give each a slight curl.

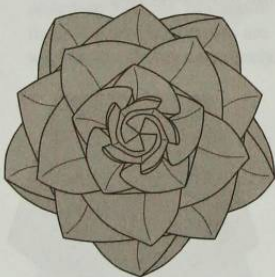

45. Finished Rose.

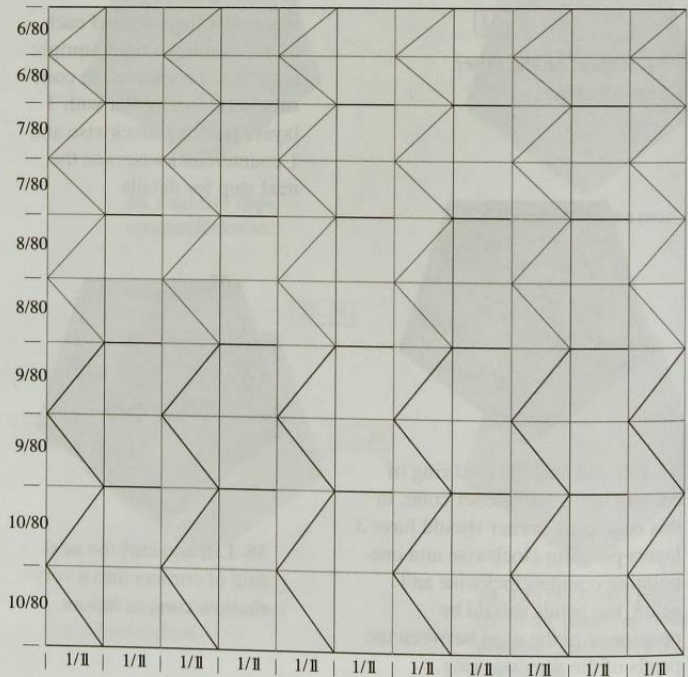

Leaf Katydid

designed by Brian Chan

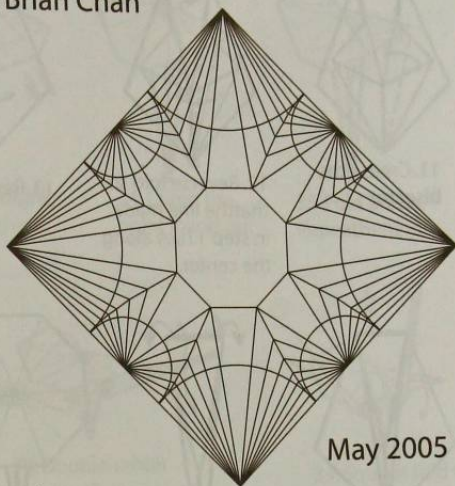
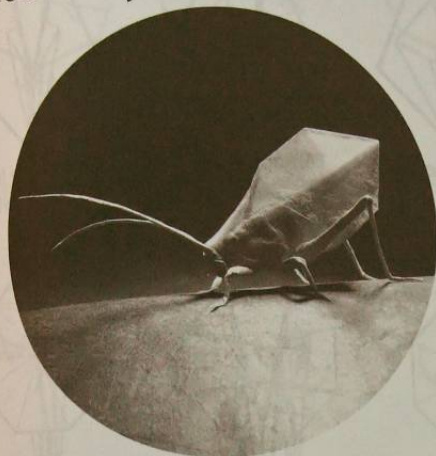

May 2005

I discovered this model while exploring the various uses of the frog base. It is best folded from thin paper, such as tissue. Start with foil paper.

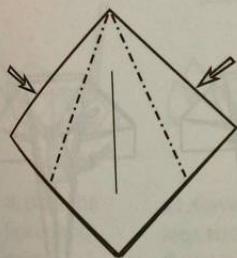

1. Start with preliminary fold, colored side up. Reverse folds.

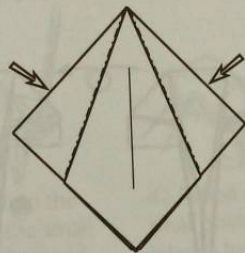

2. Repeat behind.



3. Fold one flap over, repeat behind.

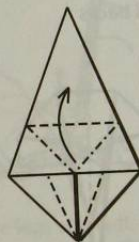

4. Petal fold.



5. Unfold to step 4.

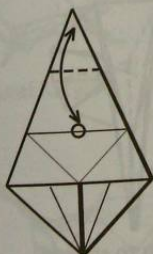

6. Fold to the horizontal line and unfold.



7. Open sink



8. Reverse fold



9. Reverse fold from the centerline.

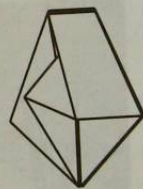

10. Repeat step 8 and step 9 on the right side

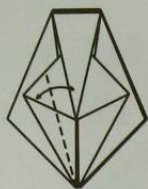

11. Crease the bisector



12. Reverse fold so that the line made in step 11 lies along the center.

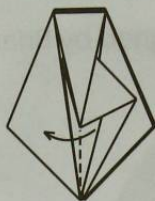

13. Reverse fold



14. Repeat steps 11-13 on the right side,



15. Reverse fold to the center line.

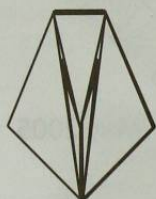

16. Repeat steps 8-15 on the sides and backs

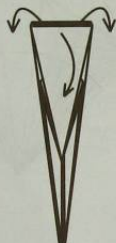

17. Open the top completely.

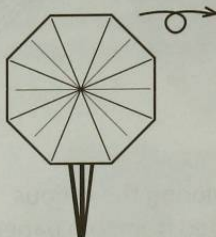

18. Flip over.



19. Note the arrangement of the layers.



20. Fold the Octagon in half.

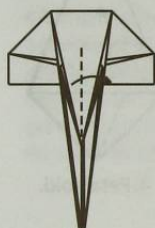

21. Partially fold the small flap to the right.



22. Spread-sink two triangles.

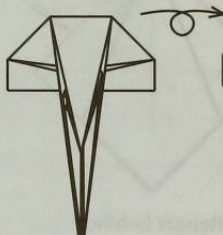

23. Flip over.



24. Repeat step 22 on the left side (not the right).



25. In progress.

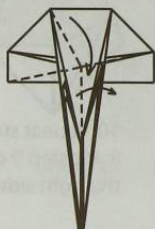

26. Fold down the edge of the octagon, while folding the small flap.

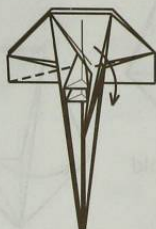

27. In progress.

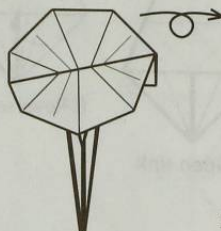

28. Flip over.



29. Similar to step 26. Note the asymmetry.



30. Reverse fold.



31. Unsink

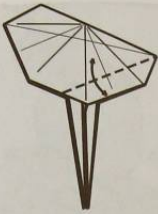

32. Crease the edge, repeat behind.

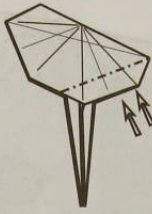

33. Closed sink, repeat behind.



34. Crimp the point in and out.

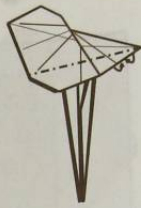

35. Fold under. Repeat behind.

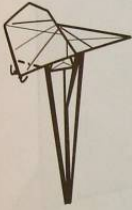

36. Reverse fold, Repeat behind.



37. Reverse fold the 4 long points.

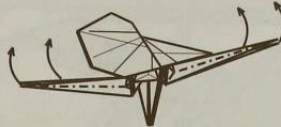

38. Double-rabbit ear the 4 long points upwards.

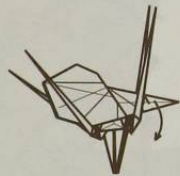

39. Squash fold the head.



40. Plead the face up and down.



41. Reverse fold the legs, tuck in the small flaps under the head. Tuck the corner.



42. Rabbit ear the 4 small points. Fold the head in half.

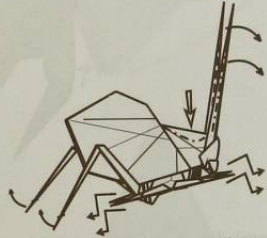

43. Shape the legs and feet. Pinch the antenna to thin them some more. Flatten the top of the thorax (behind the head).

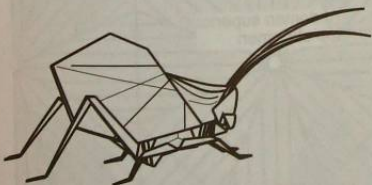

44. Finished Leaf Katydid.

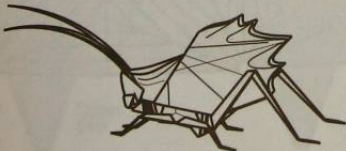

Variation: shape the wings so that they look like a "dead-leaf" katydid. In nature, there is a wide variety of different species. Patience in the final shaping of the model makes all the difference.

**ESPECTRO DE
MACLEAY.**
(Insecto palo-hoja)

Walking stick-leaf

(c) M. Sirgo. 2006

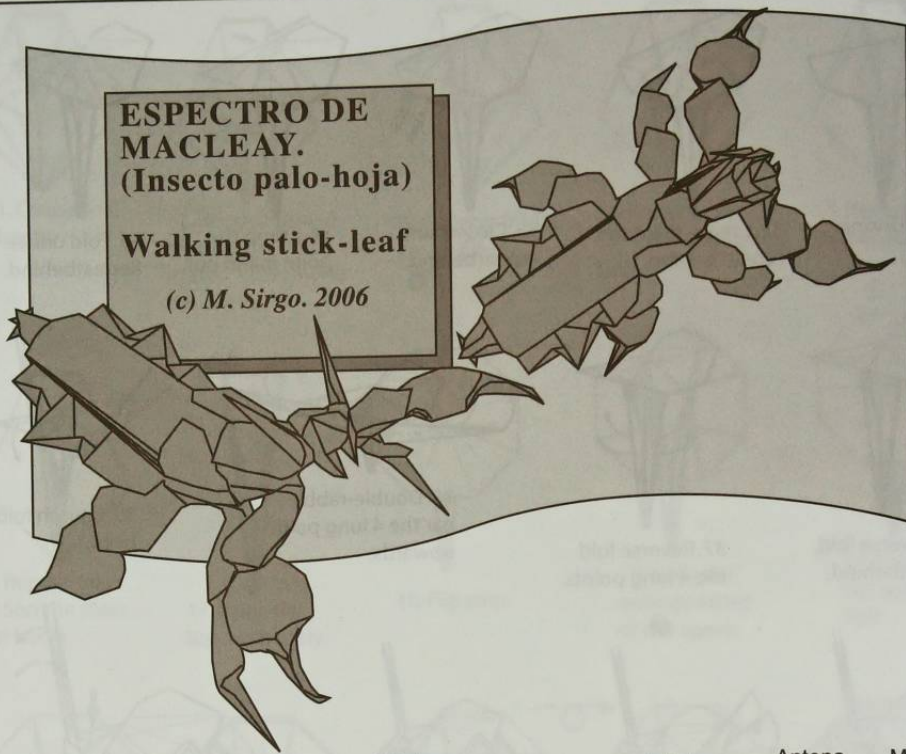

El papel debe ser verde o marrón. Se recomienda papel fino, menor de 30 gramos, doble seda, banana, lokta, metalizado o sandwich de 30x30 cm o mayor.

The paper should be green or brown. Fine paper is recommended, smaller than 30 grams, double silk, banana tree, lokta, metalized or sandwich of 30x30 cm or bigger.

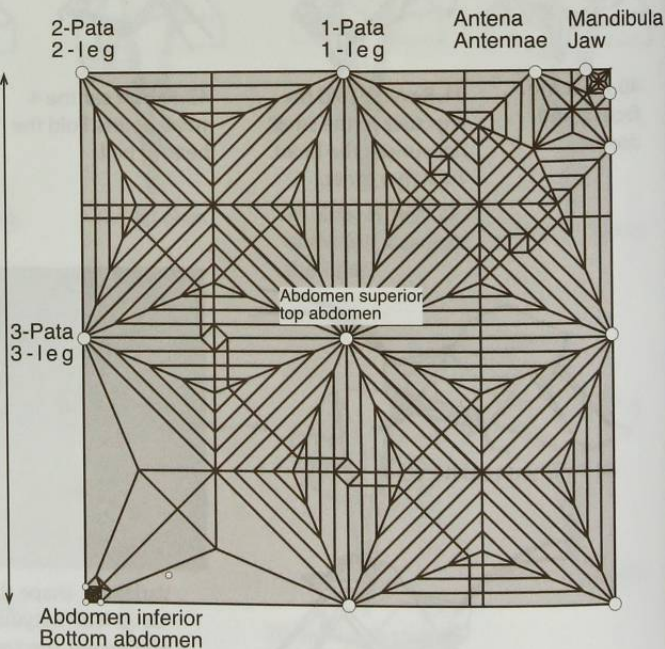
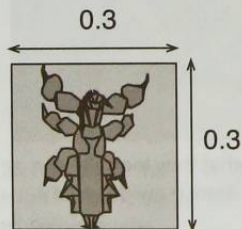

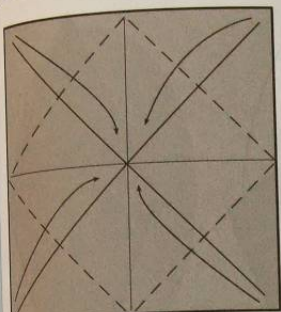

1

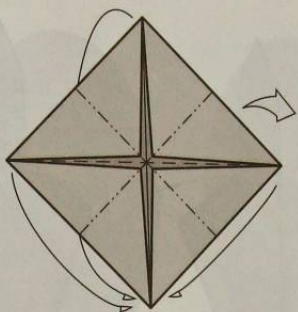

2

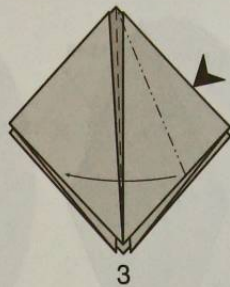

3

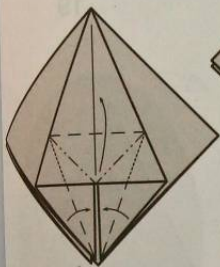

4

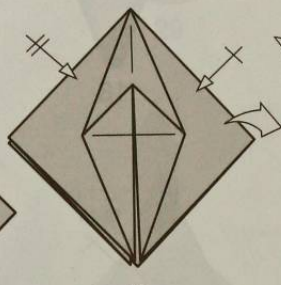

5

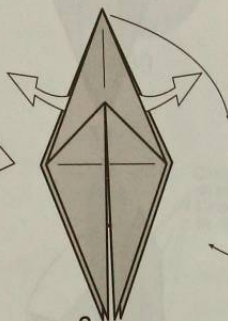

6

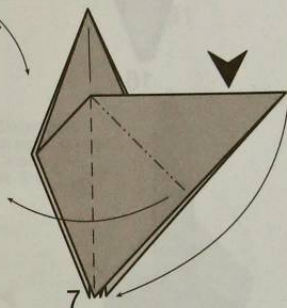

7

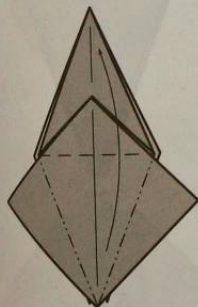

8

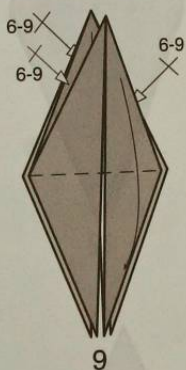

9

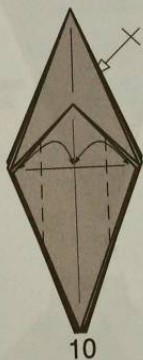

10

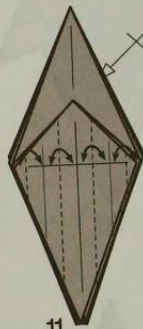

11

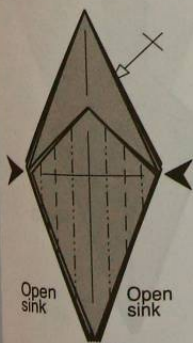

Open sink

Open sink

12



13

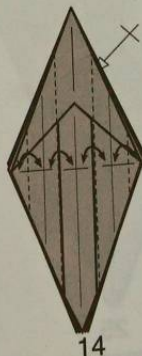

14

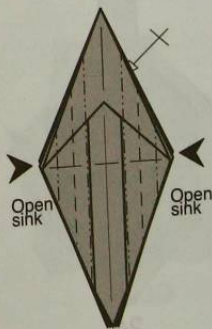

Open sink

Open sink

15

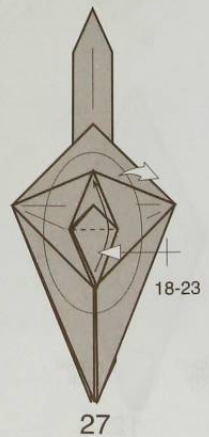
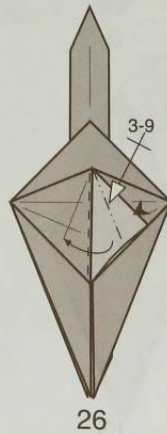
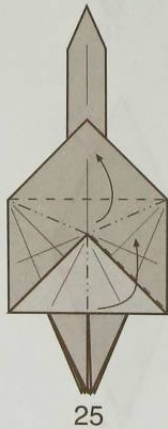
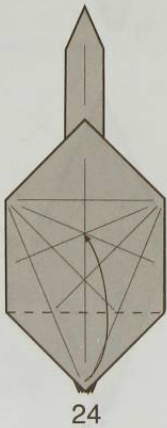
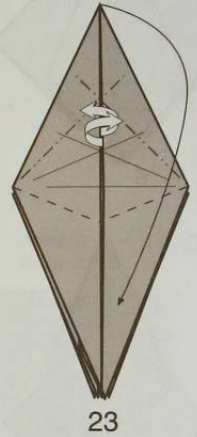
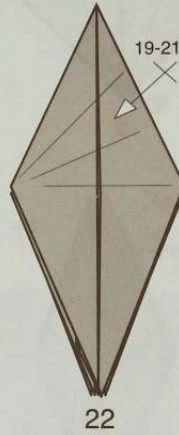
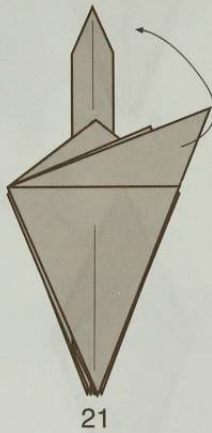
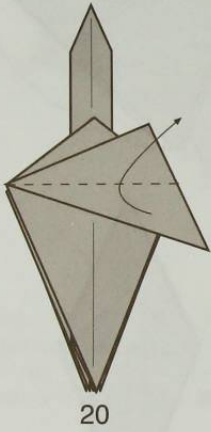
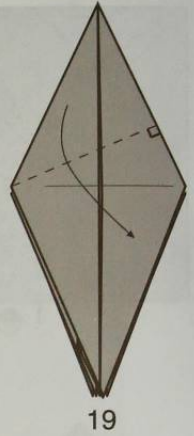
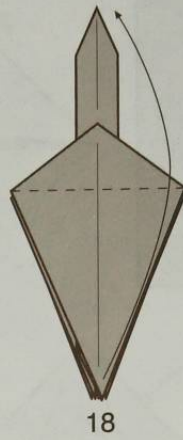
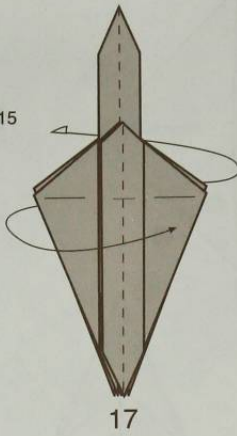
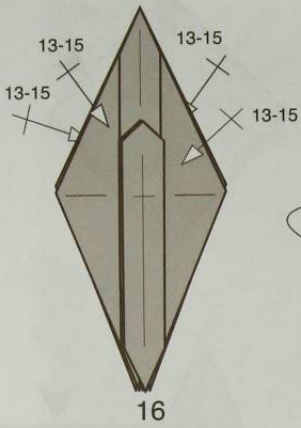

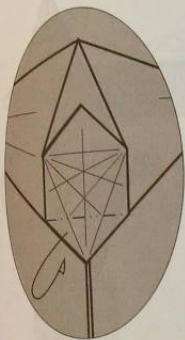

28

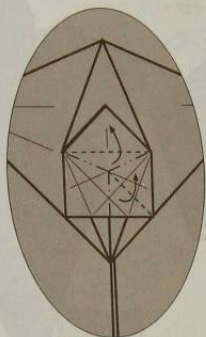

29

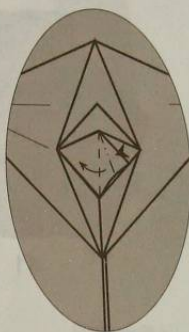

30

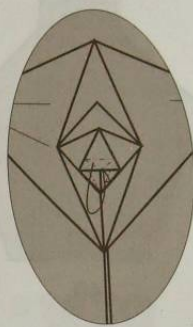

31

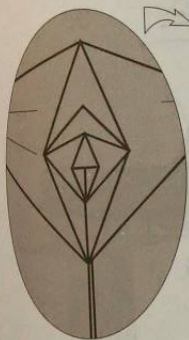

32

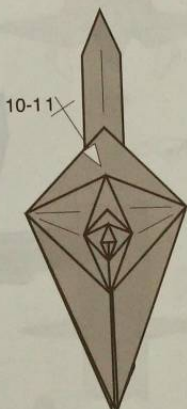

33

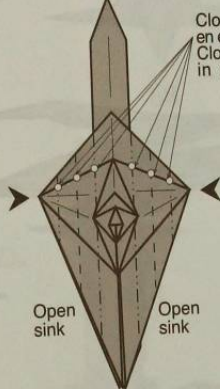

34

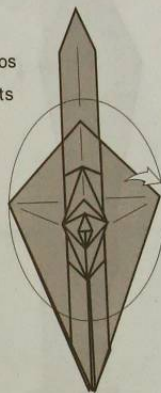

35

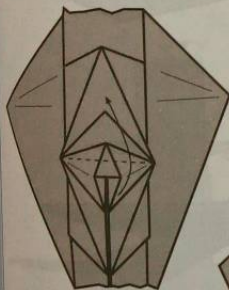

36

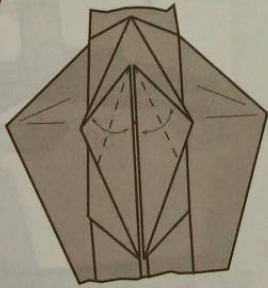

37

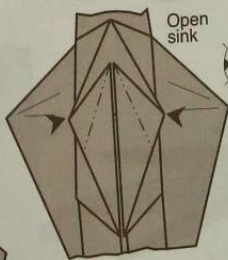

38

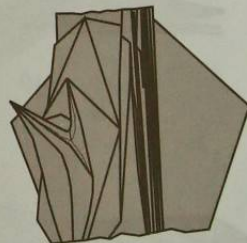

39-3D

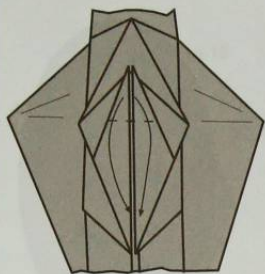

40

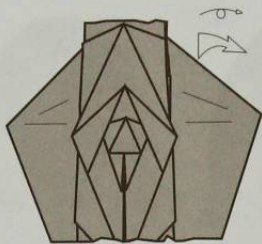

41

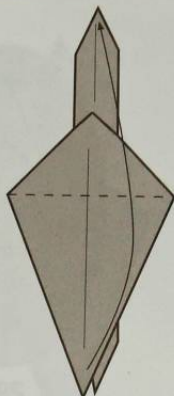

42

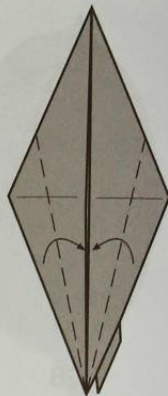

43

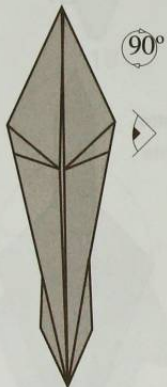

44



45

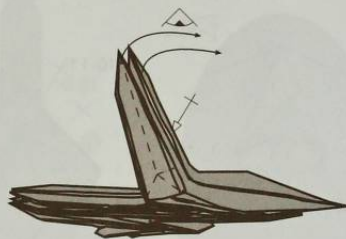

46

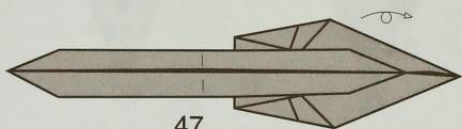

47

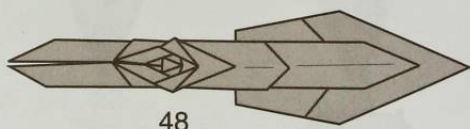

48

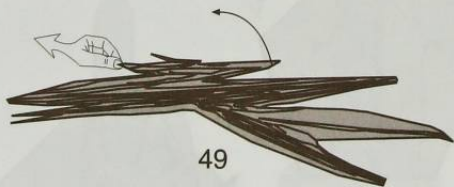

49

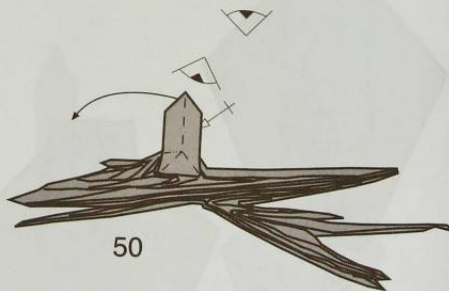

50

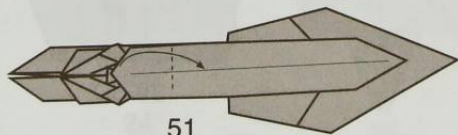

51

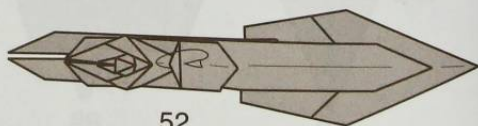

52

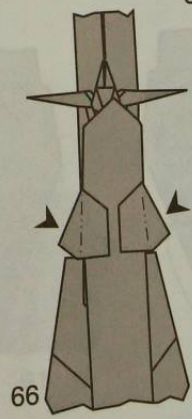
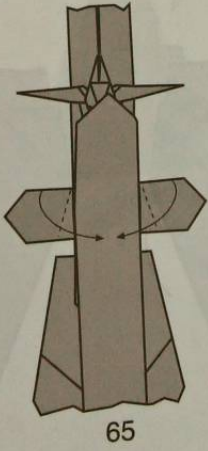
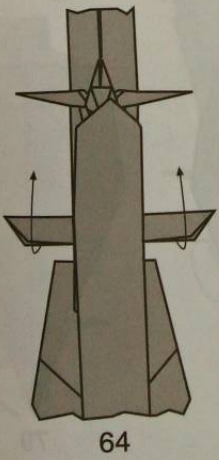
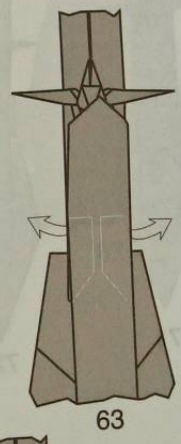
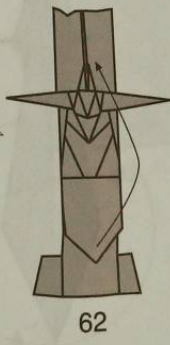
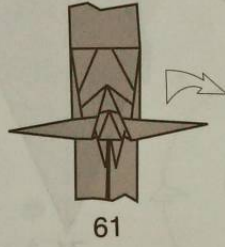
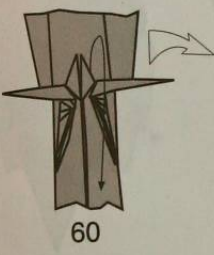
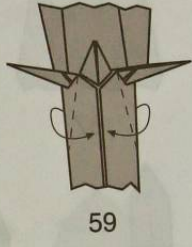
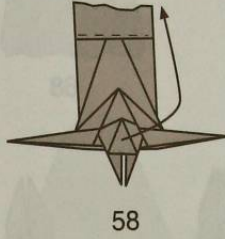
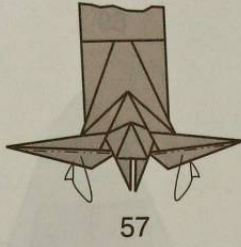
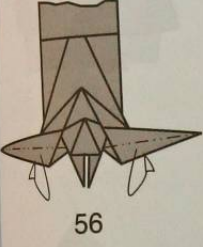
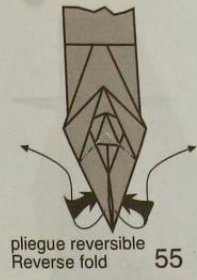
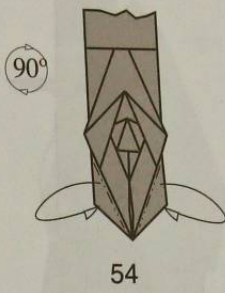
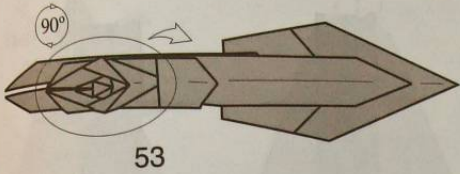

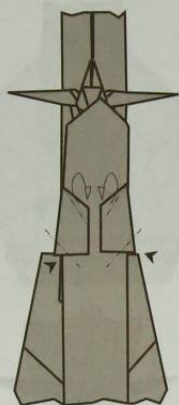

67

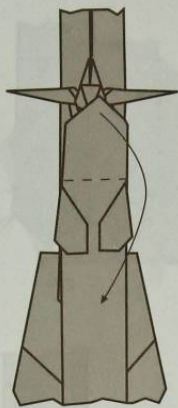

68

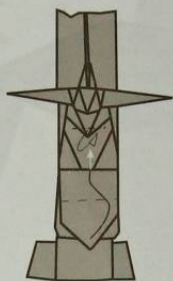

69

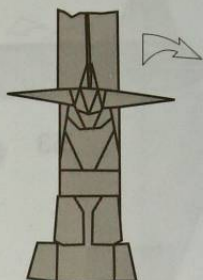

70

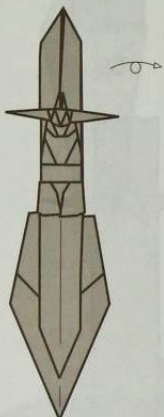

71

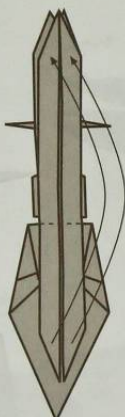

72

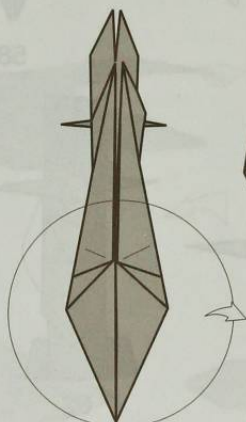

73

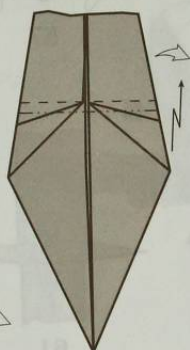

74

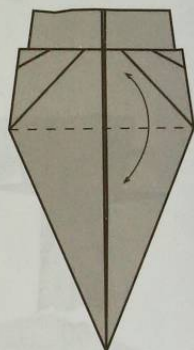

75

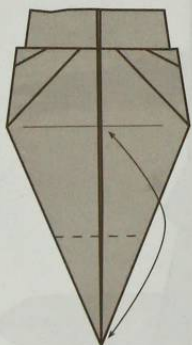

76

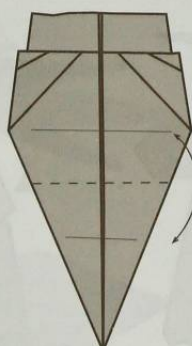

77

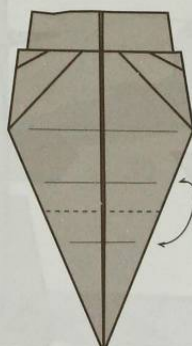

78

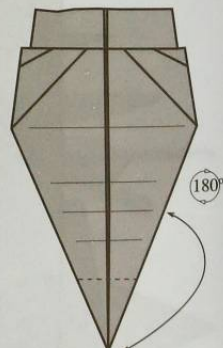

79

180°

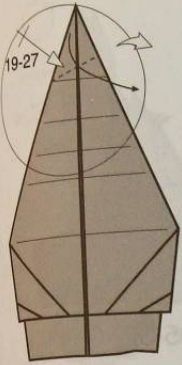

80

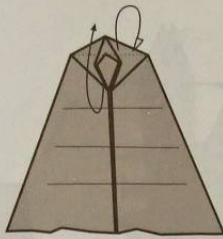

81

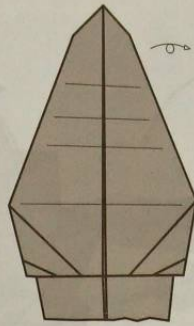

82

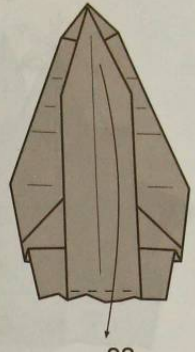

83

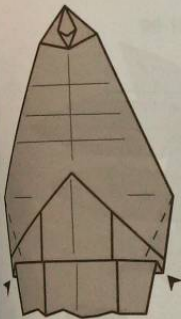

84

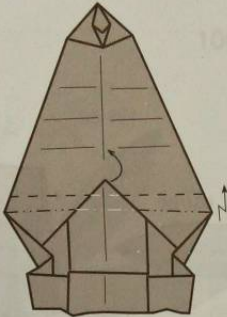

85

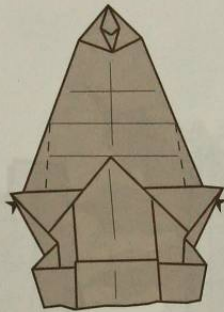

86

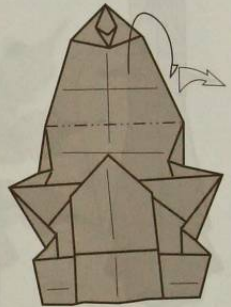

87

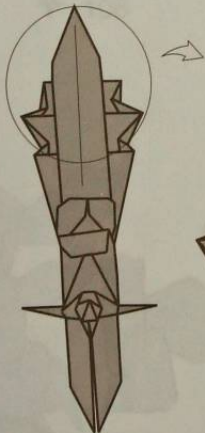

89

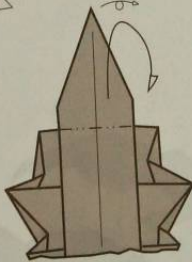

90

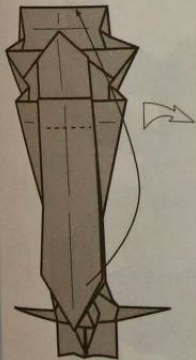

88

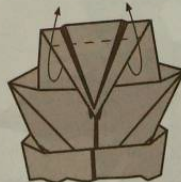

91

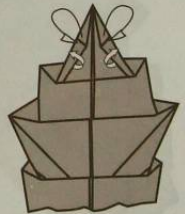

92

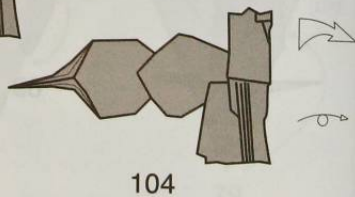
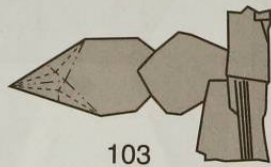
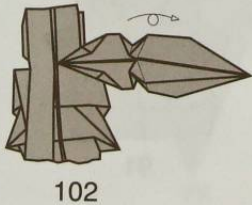
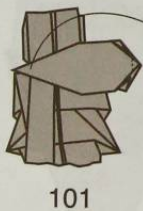
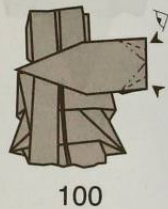
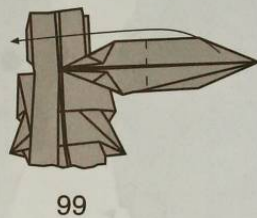
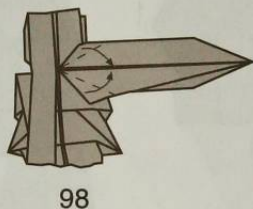
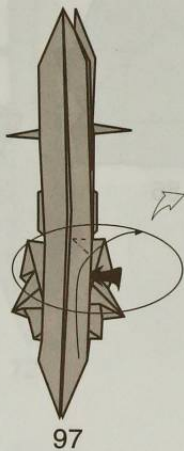
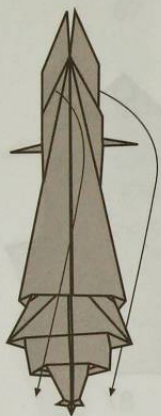
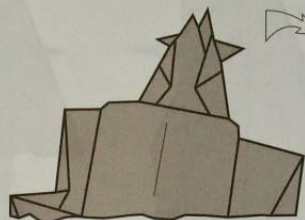
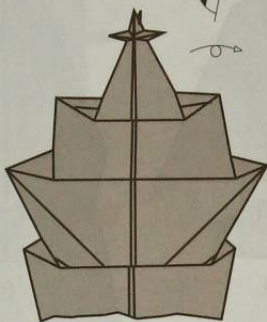
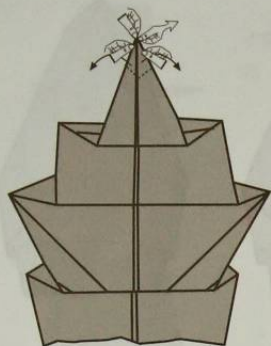

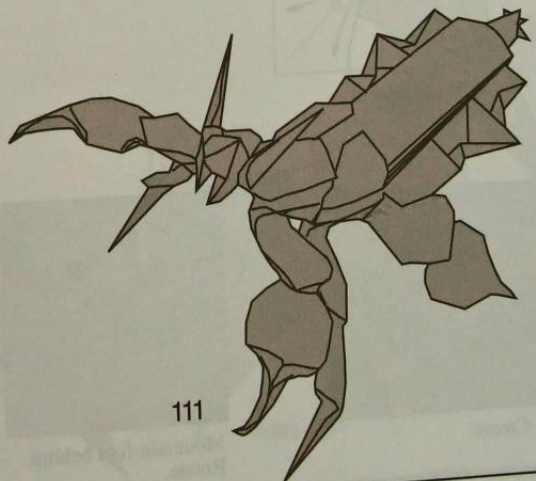
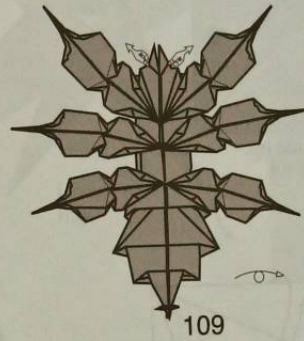
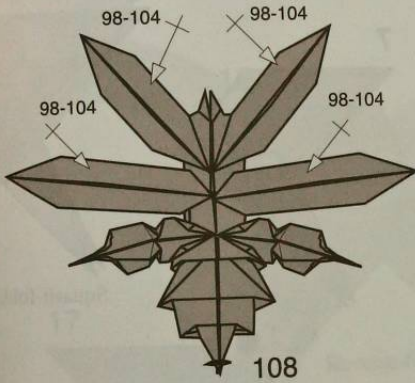
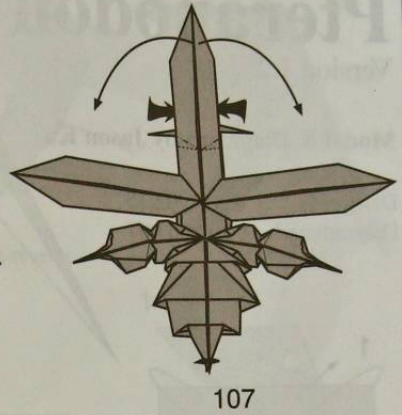
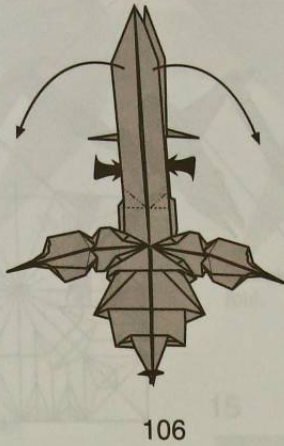
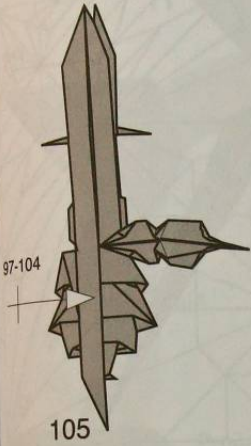

Pteranodon

Version 1.2

Model & Diagrams by Jason Ku

Designed: ©2005/02/15

Diagrammed: ©2005/03/07

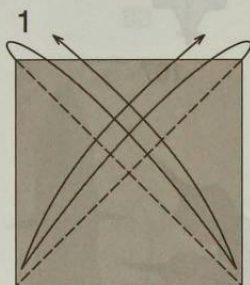
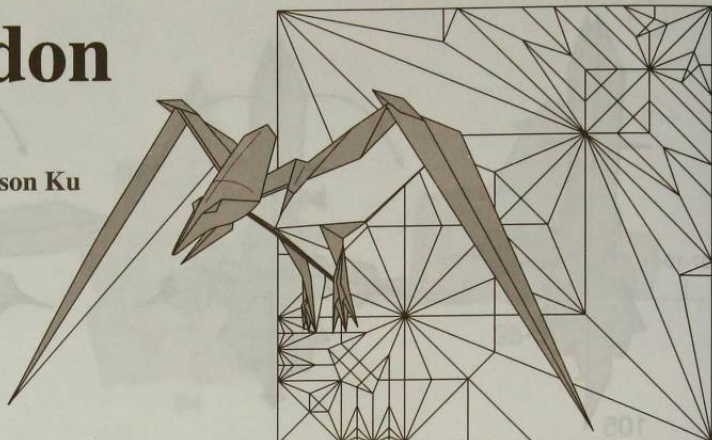

1
Start color side up.
Fold and unfold.
Turn over.

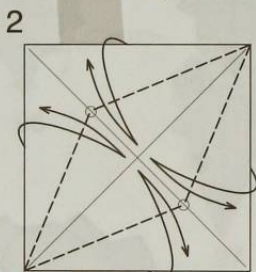

2
Fold and unfold.
Turn over.

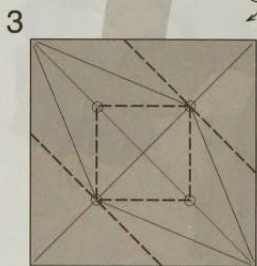

3
Crease.

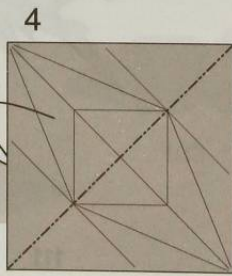

4
Mountain-fold behind.
Rotate.

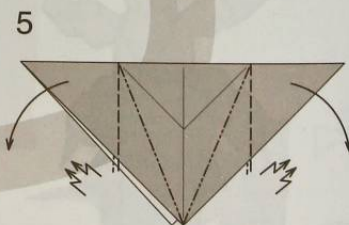

5
Crimp both sides along
existing creases.

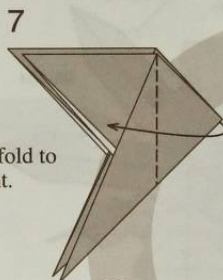

6
Valley-fold to
the right.

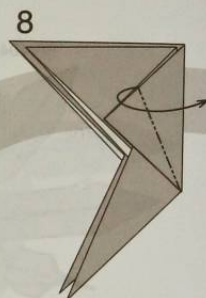

7
Squash-fold.

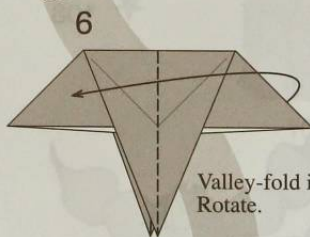

8
Valley-fold in half.
Rotate.

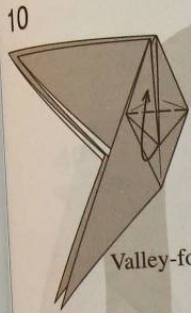

Valley-fold.

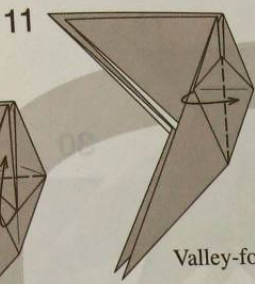

Valley-fold.

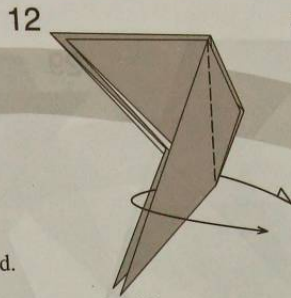

Outside-reverse fold.

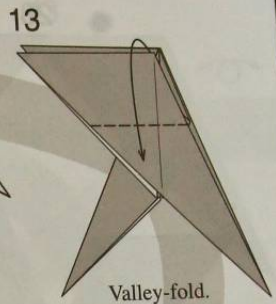

Valley-fold.

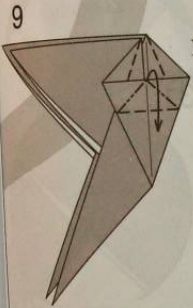

Petal-fold.

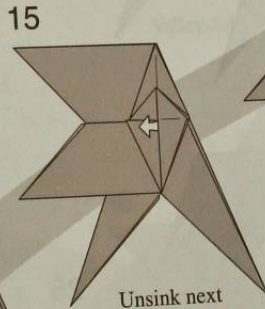

Unsink next flap.

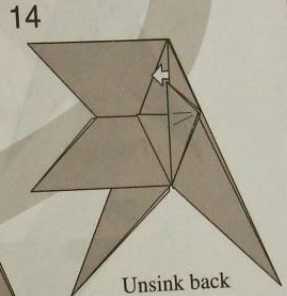

Unsink back flap.

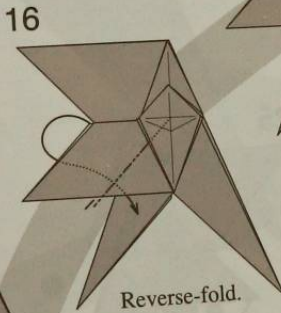

Reverse-fold.

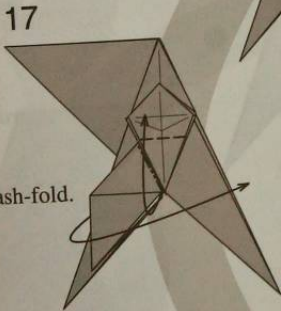

Squash-fold.

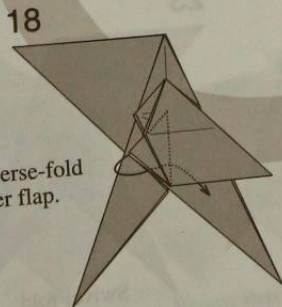

Reverse-fold inner flap.

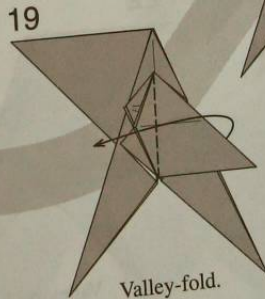

Valley-fold.

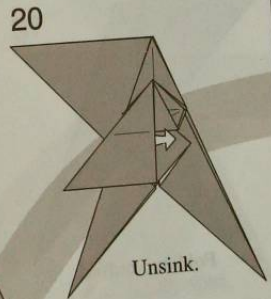

Unsink.

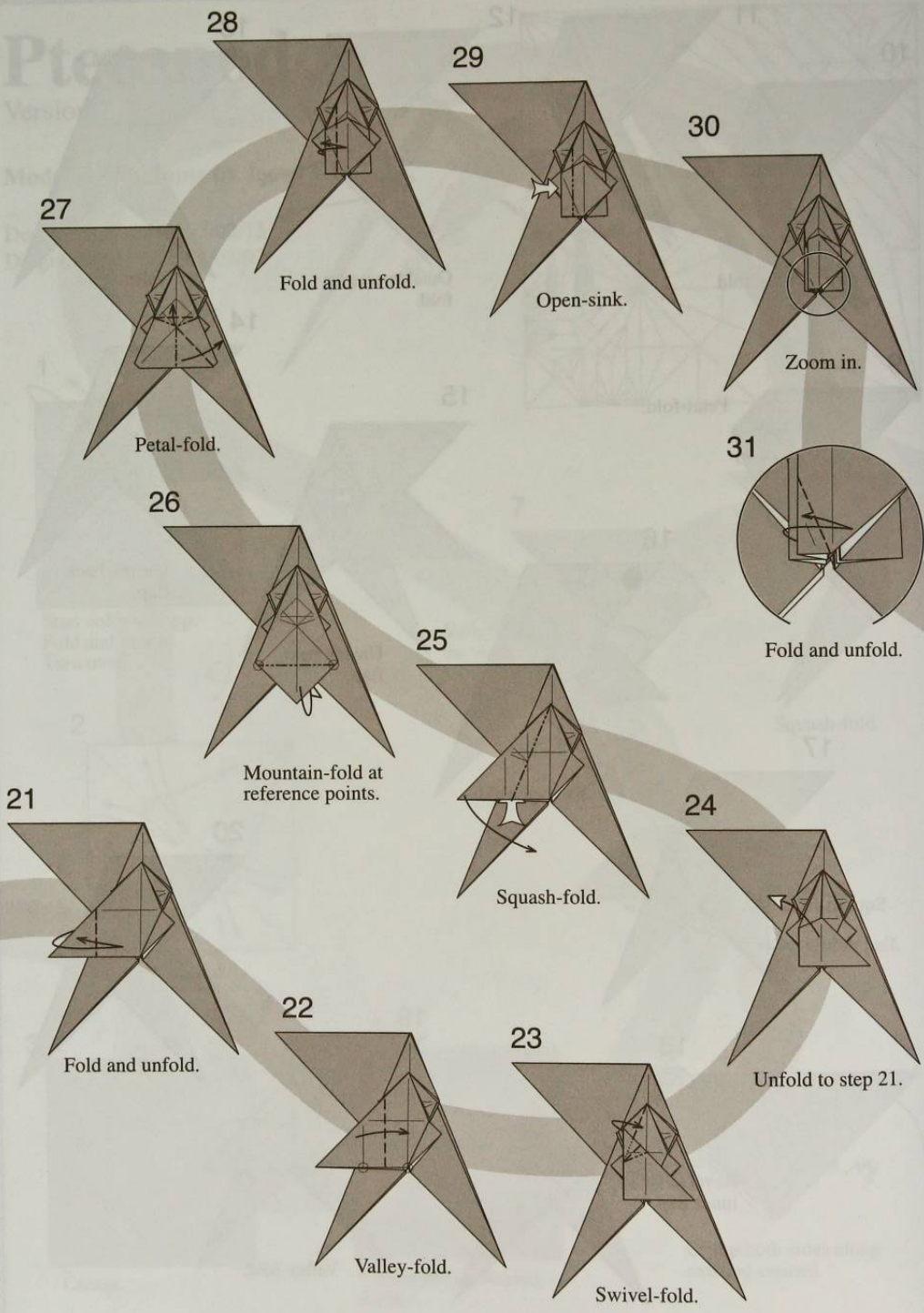

40



Reverse-fold.

41

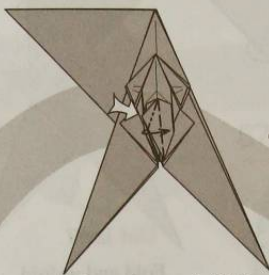

Spread-squash-fold.

42



Valley-fold.

43

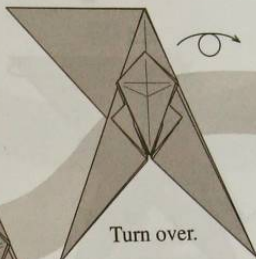

Turn over.

39

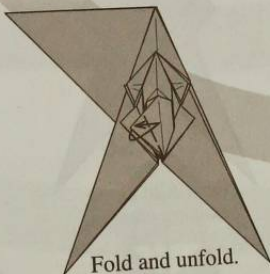

Fold and unfold.

38

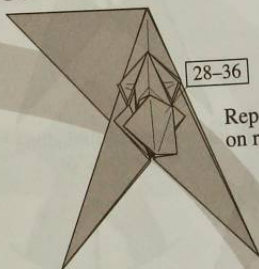

28-36

Repeat steps 28-36 on right.

32

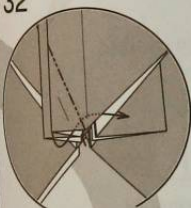

Reverse-fold.

37

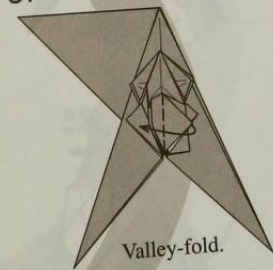

Valley-fold.

33

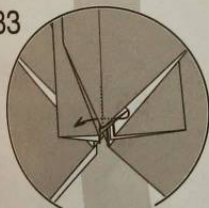

Reverse-fold.

36

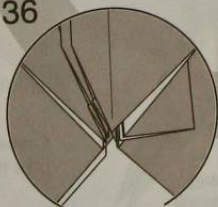

Zoom out.

35

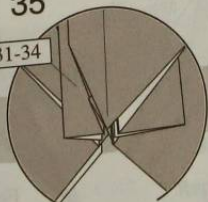

31-34

Repeat steps 31-34.

34

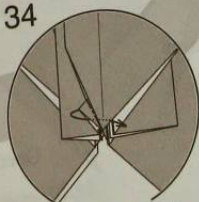

Reverse-fold.

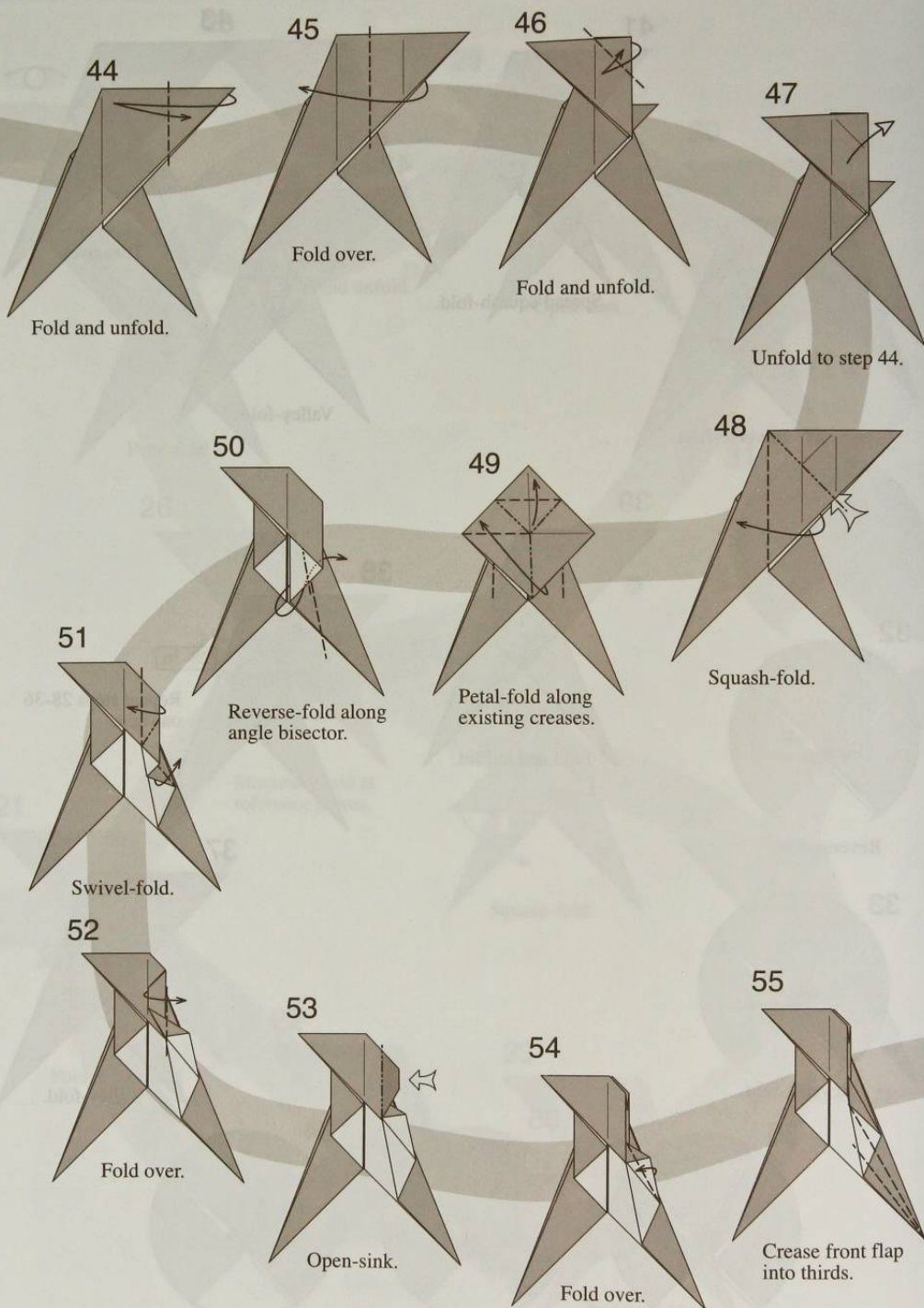

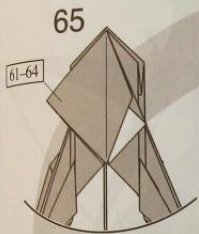

Repeat steps 61-64 on right.

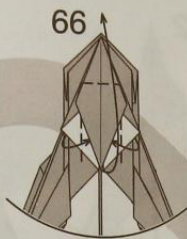

Petal-fold.

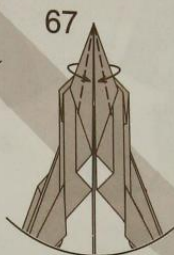

Kite-fold.

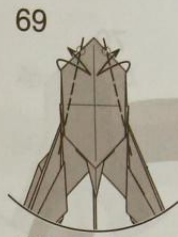

Fold and unfold. Do not fold to a point.

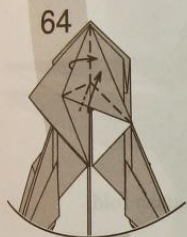

Collapse.

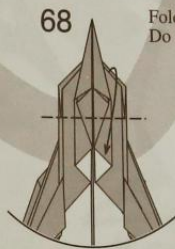

Valley-fold.

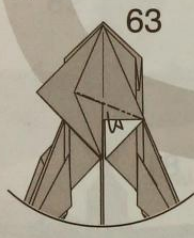

Mountain-fold.

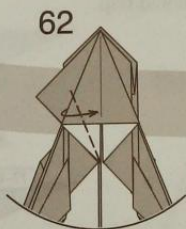

Valley-fold.

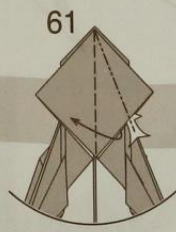

Squash-fold.

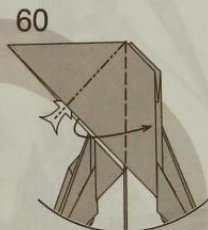

Squash-fold.



Reverse-fold.

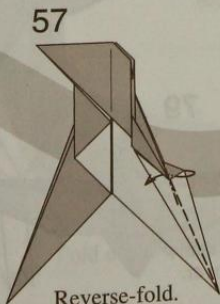

Reverse-fold.

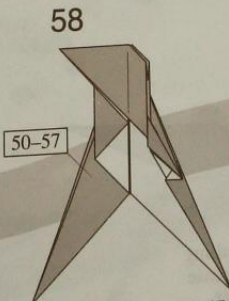

Repeat steps 50-57 on left.

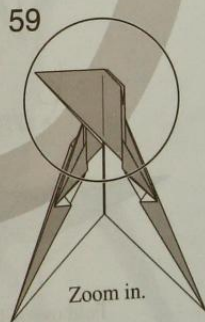

Zoom in.

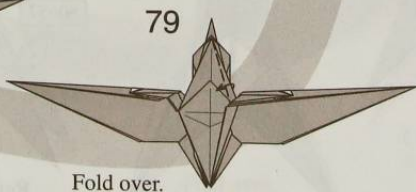
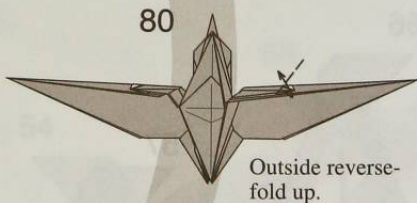
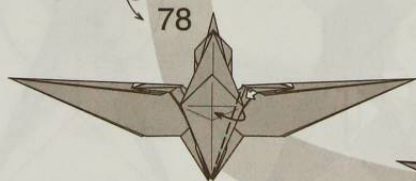
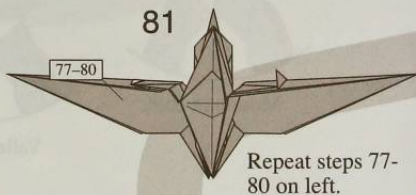
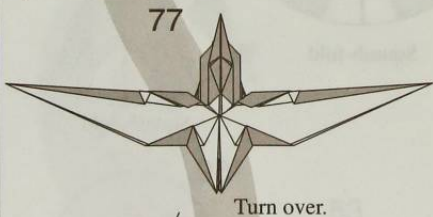
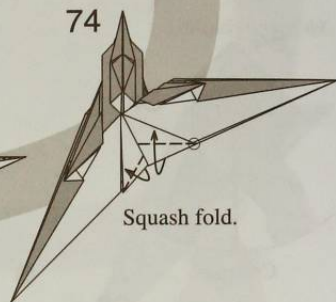
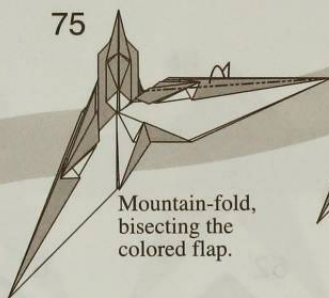
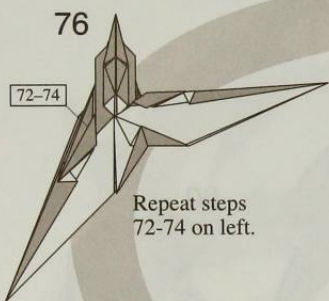
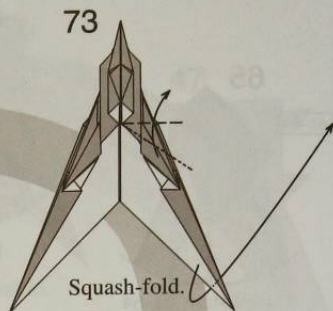
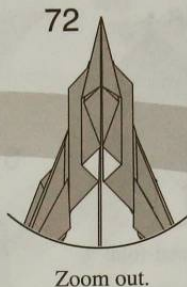
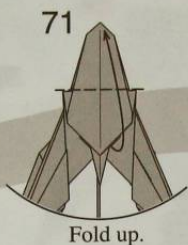
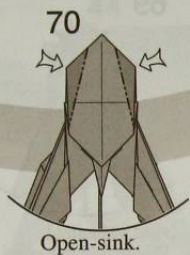

84

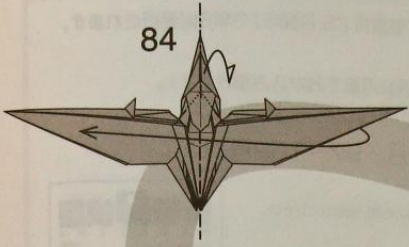

Valley-fold in half while rabbit-earing the head down. Rotate.

83

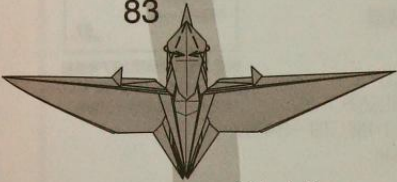

Kite-fold.

82

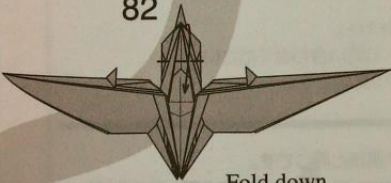

Fold down.

89

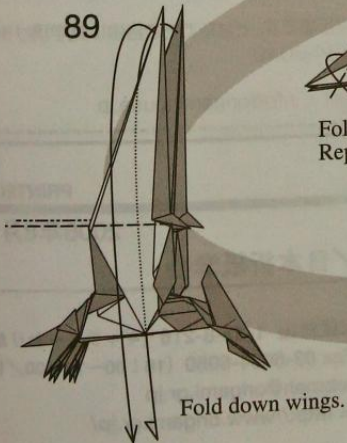

Fold down wings.

85

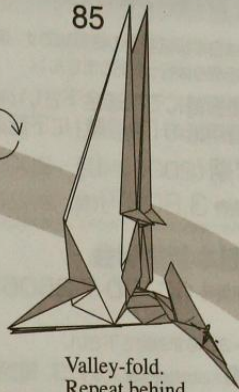

Valley-fold. Repeat behind.

86

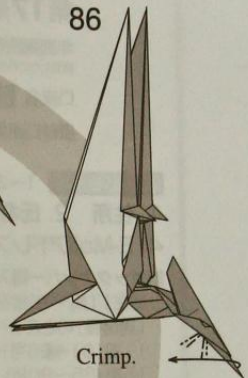

Crimp.

88

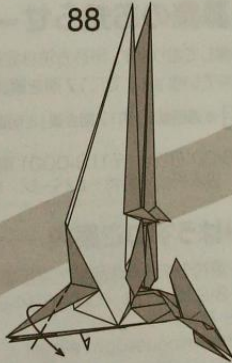

Fold over. Repeat behind.

87

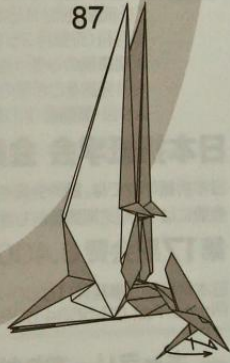

Outside reverse-fold.

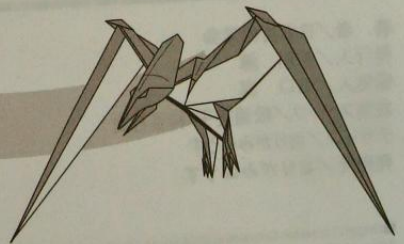

雑誌『折紙探偵団』年間購読のご案内

雑誌『折紙探偵団』は日本折紙学会の機関誌です。隔月刊(奇数月25日発行)で年6回発行されます。年間購読制です(ばら売りは行っておりません)。

- 申込方法**
1. 郵便振替にてご送金下さい(普通の振替用紙でお申込み頂けます)。
 2. 振替用紙の「通信欄」に下記必要事項をご記入下さい。

第17期(2006年4月~2007年3月/97~102号)

年間購読費 3,800円(税、送料込み)

期変わりに料金が変更になる場合があります。2007年以降は事務局にお問い合わせください。

口座名 **日本折紙学会**

振替口座番号 00170-7-260699



雑誌『折紙探偵団』97号表紙
表紙フルカラー/本文38ページ
(カラー口絵2ページ含む)

記入必要事項 1~3は必ずお書き下さい。

1. 住所
2. 氏名 ※ふりがなをお願いします。
3. 電話、FAX番号
4. E-Mailアドレス
5. 性別
6. 生年月日
7. 職業

■バックナンバー購入について

現在11期~16期を取り扱っております。購入ご希望の場合は、「通信欄」のところへ希望する期を明記の上、相当金額をお振込み下さい。

11期(61~66号)・12期(67~72号)・13期(73~78号)・14期(79~84号)

15期(85~90号)・16期(91~96号) 各3,800円(税、送料込み)

■雑誌『折紙探偵団』について

・『折紙探偵団』は日本折紙学会の機関誌です。購読には学会会員である必要はありません。

・隔月刊(奇数月25日発行)で年6回発行されます。

・年間購読のみ受け付けています。ばら売りは行っておりません。

・海外発送をご希望の場合は料金が異なります。事務局へお問い合わせください。

・折り図・展開図・折り紙研究・エッセイ・最新情報など充実の誌面です。

日本折紙学会 会員募集のお知らせ

日本折紙学会では、随時会員を募集しております。申込方法は定期購読と同じです。

会費には17期定期購読料も含まれています(すでに17期を購読されている方は4,600円となります)。

第17期会費 8,400円 ※通信欄に「第17期会費」と明記してください

日本折紙学会事務局(10:00~18:00 日祝休) 〒113-0001 東京都文京区白山 1-33-8-216
Phone/Fax 03-5684-6080 日本折紙学会ホームページ <http://www.origami.gr.jp/>

ギャラリーおりがみはうすのご案内

1989年にオープンした日本で最初の折り紙作品専門展示場です。どなたでもご自由に見学頂けます。

住所/東京都文京区白山 1-33-8-216 TEL/03-5684-6040

営業時間/10:00~18:00(日・祝休)

ホームページ = <http://www.origamihouse.jp/> e-mail = info@origamihouse.jp

第12回 折紙探偵団コンベンション折り図集

PRINTED IN JAPAN

2006年8月12日発行

著者/日本折紙学会

発行人/前川 淳

編集人/山口 真

編集スタッフ/松浦英子・神谷哲史

デザイン/おりがみはうす

発売元/おりがみはうす

発行所/日本折紙学会

113-0001

東京都文京区白山 1-33-8-216 (ギャラリーおりがみはうす内)

Phone & Fax 03-5684-6080 (10:00~18:00/日・祭日休)

E-mail = webman@origami.gr.jp

Web Site = <http://www.origami.gr.jp/>

■OrigamiTanteidan Convention Book vol.12 / Published on 12, August 2006 by Japan Origami Academic Society, 1-33-8-216 Hakusan Bunkyo-ku 113-0001 Tokyo JAPAN / Publisher : Maekawa Jun / Editor in Chief : Yamaguchi Makoto / Editorial Design : OrigamiHouse